

XM Satellite Radio, Inc. In-Vehicle Measurement Procedures

EQUIPMENT LIST

Type	Manufacturer	Model No.	Cal Date	Due Date
Spectrum Analyzer	Rohde & Schwarz	FSIQ7	3/28/2006	3/28/2007
Low Noise Amp	Sonoma	Inst 310	6/9/2006	6/9/2007
Biconilog Antenna	ETS-Lindgren	3142C	6/5/2006	6/5/2007

Test Vehicles

Cadillac Escalade
Toyota Camry
Nissan Maxima

TEST PROCEDURE

1. The satellite radio receiver and FM Coupler was installed in each vehicle per the installation guidelines provided to the user and tuned to one of the three test FM frequencies.
2. The RBW and VBW of the spectrum analyzer were set to 120KHz and 300KHz respectively. A peak detector was utilized.
3. For tests where the receiving antenna is in Vertical polarization, the receive antenna is initially placed at one meter from the ground. For Horizontal polarization, the receive antenna is initially placed at three meters from the ground.
4. While monitoring the power of the fundamental FM emission, the receive antenna base is moved horizontally along one of the vehicles sides, at 3 meters from the vehicle. The position that produces the highest emission is found.
5. At the position found in step (4) above, the antenna is moved vertically from 1 meter to 4 meters. The highest FM emission is found and recorded.
6. The above procedure is repeated for each of the four sides of the vehicle.
7. The above procedure is repeated for each of three FM frequencies (88.7MHz, 96.9MHz, and 107.1MHz).
8. The cable loss, amplifier gain, and antenna factors are used to determine the absolute field strength from each peak power measurement as shown in the table below.
9. For spurious emissions spurs identified during the bench test were used as preliminary data to rescan during the vehicle level test.

Test Frequency	Vertical Polarization V-Factor	Horizontal Polarization H-Factor
88.7MHz	-19.2 dB	-18.8 dB
96.9MHz	-20.0 dB	-18.2 dB
107.1MHz	-21.0 dB	-18.7 dB

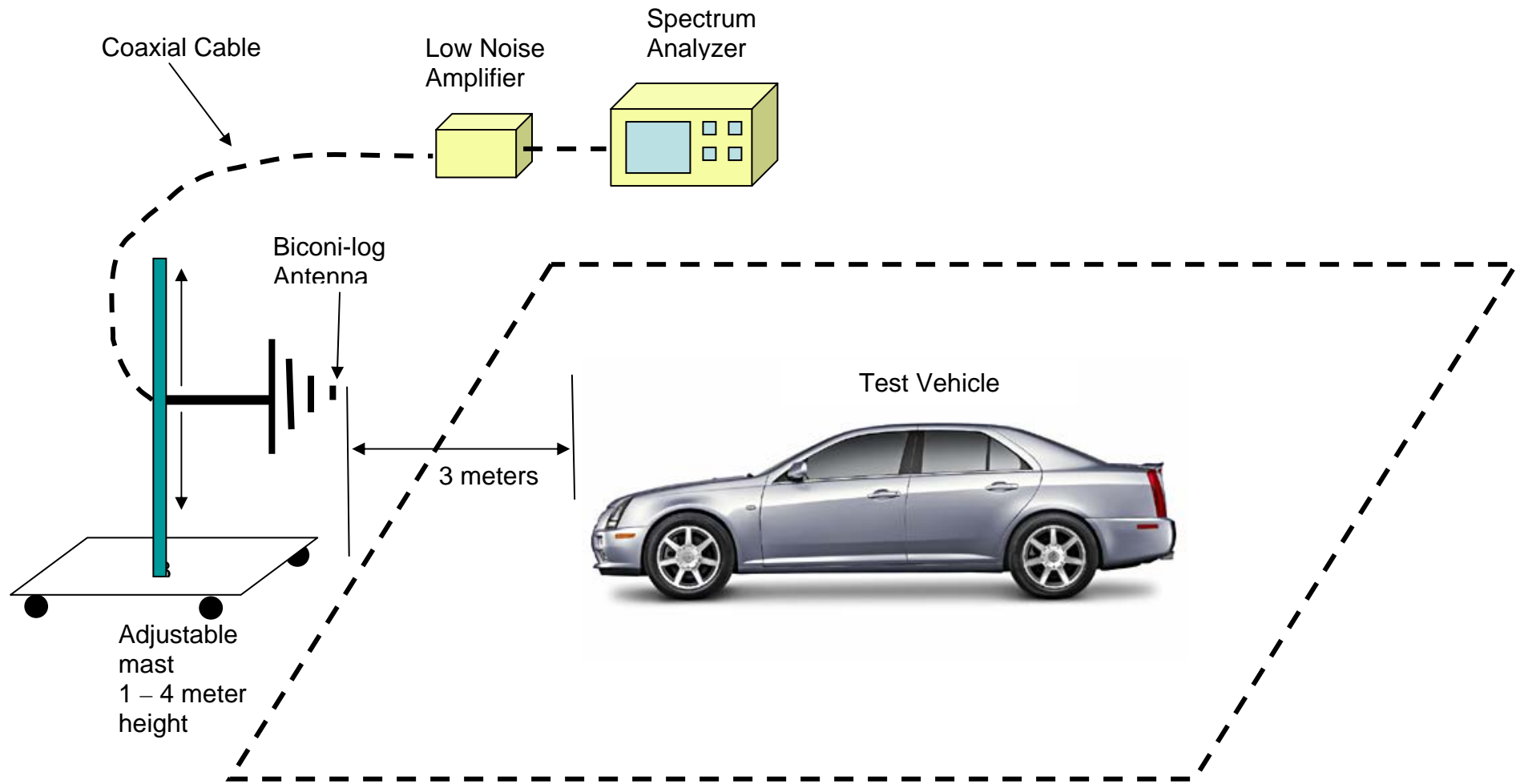

Figure 1. In Vehicle Measurement Diagram

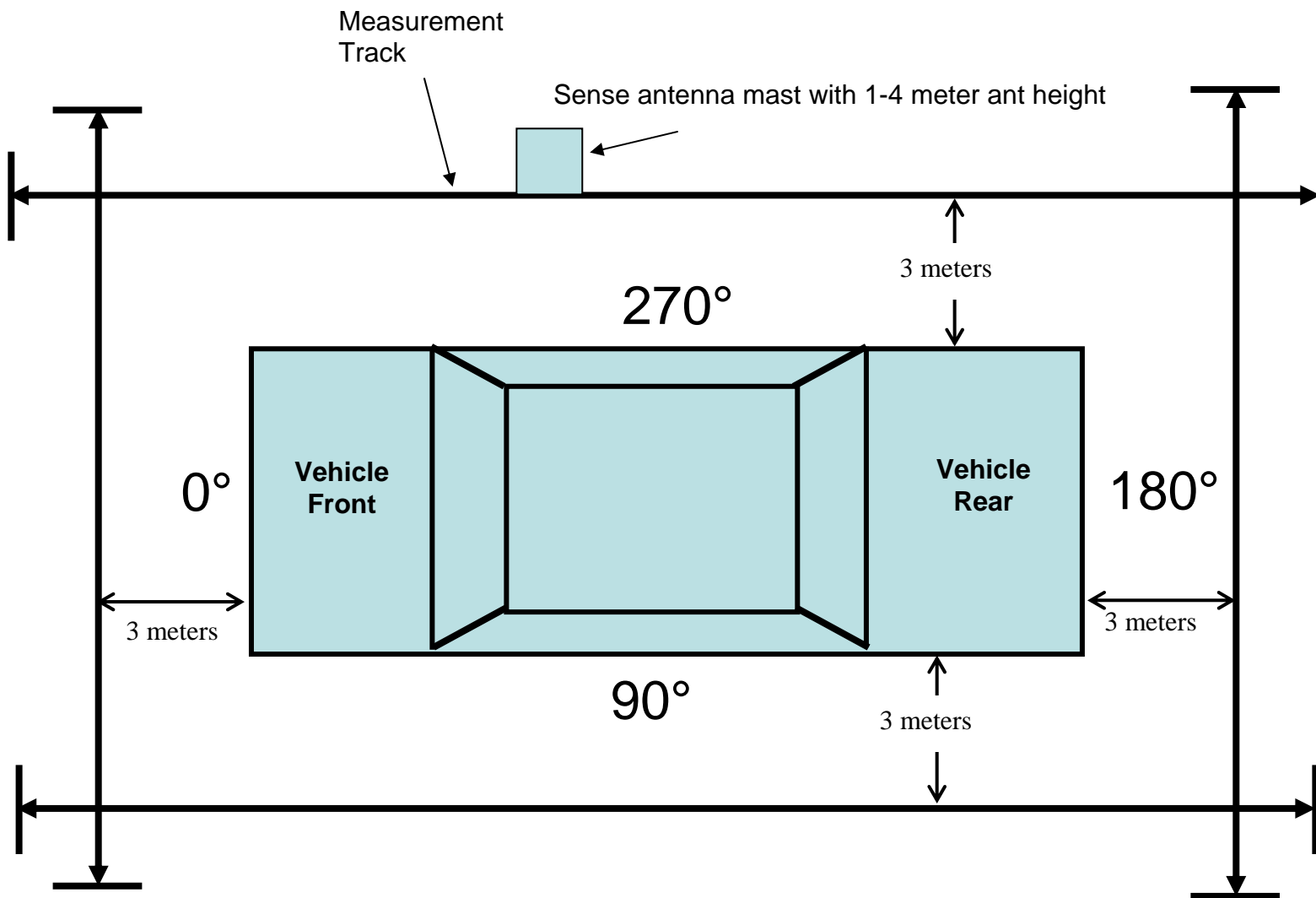

Figure 2. In Vehicle Measurement Diagram