

THE Δ SYMBOL MARK OF THIS SCHEMATIC DIAGRAM INCORPORATES SPECIAL FEATURES IMPORTANT FOR PROTECTION FROM X-RADIATION. FILURE AND ELECTRICAL SHOCK HAZARDS. WHEN SERVING IT IS ESSENTIAL THAT ONLY MANUFACTURERS SPECIFIED PARTS BE USED FOR THE CRITICAL COMPONENTS IN THE Δ SYMBOL MARK OF THE SCHEMATIC.

**SECRET**  
 LGElectronics

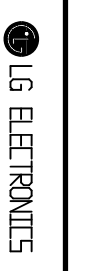

**MODEL** W43 DUAL MSTAR **DATE** 2008-09-17  
**BLOCK** SCALER **SHEET** 1 / 2

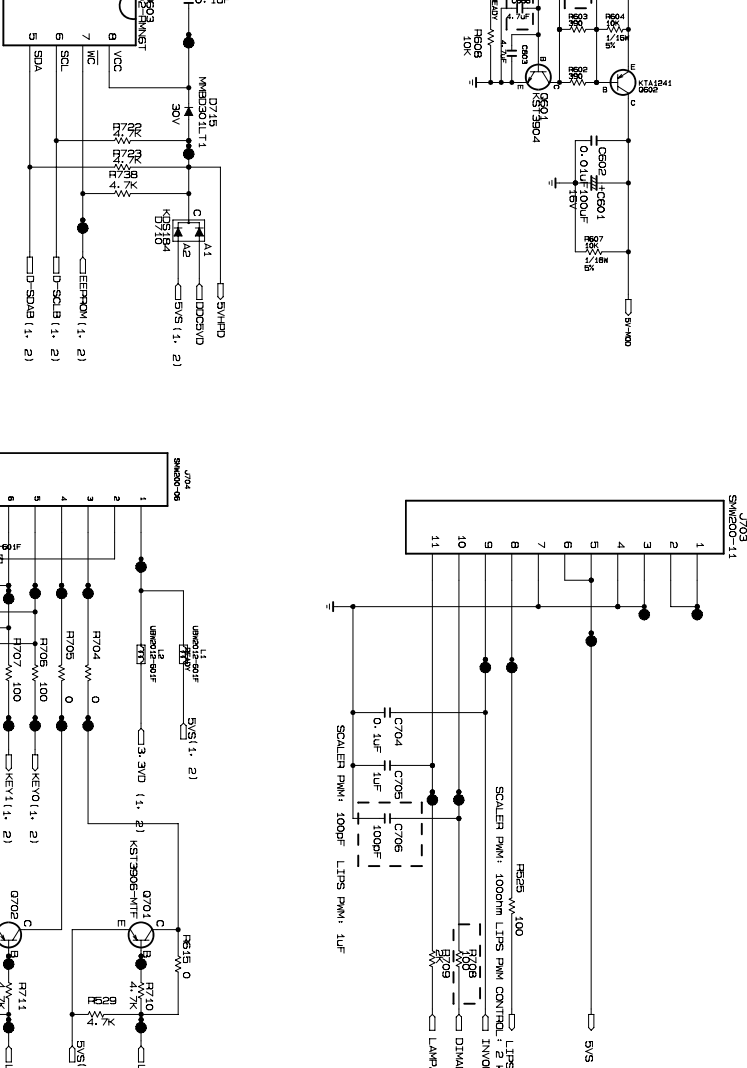
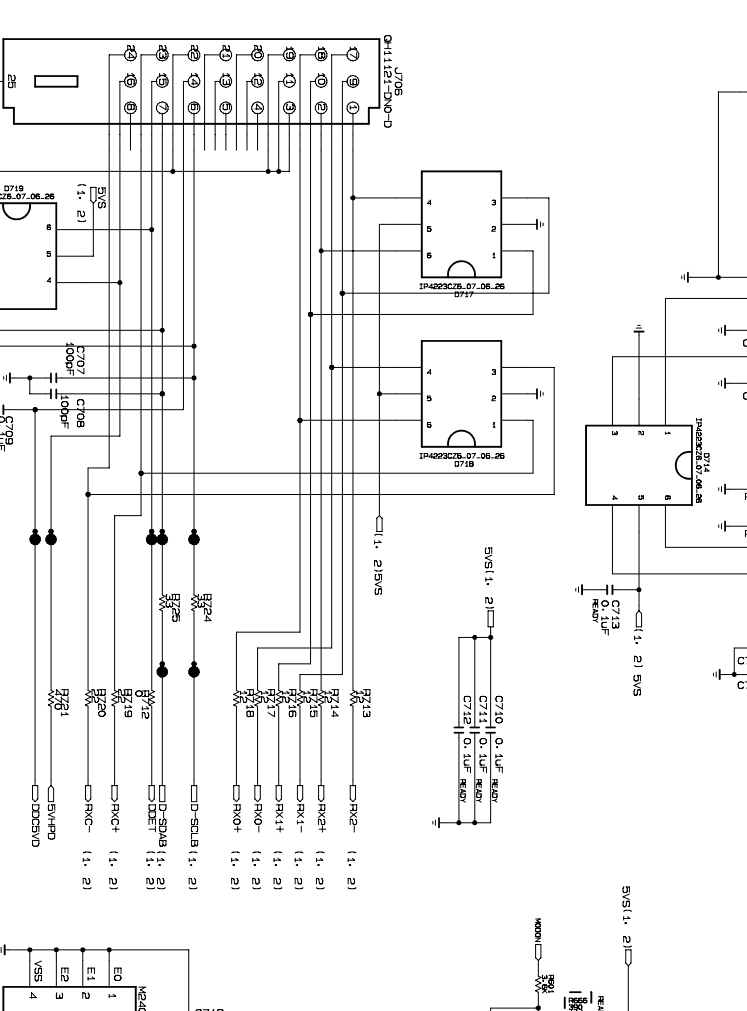
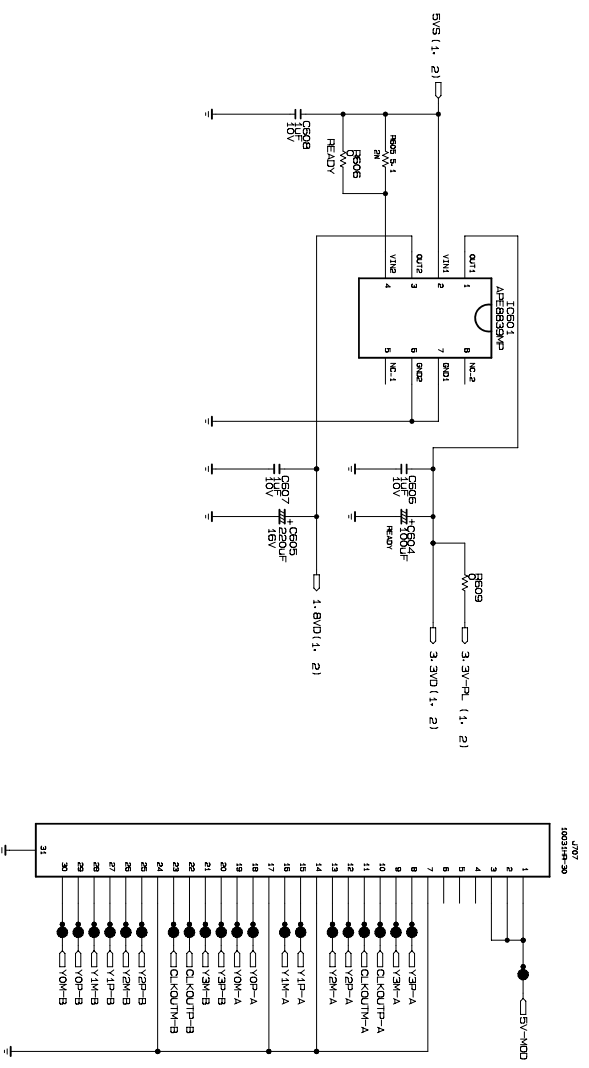
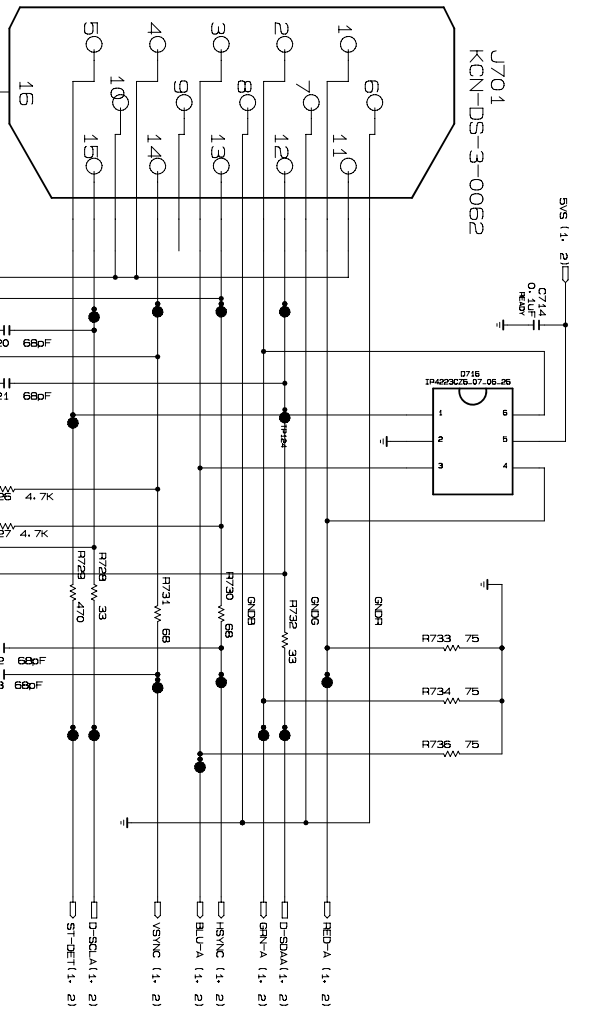

THE SYMBOL MARK OF THIS SCHEMATIC DIAGRAM INDICATES SPECIAL FEATURES IMPORTANT FOR PROTECTION FROM X-RADIATION. FILE AND ELECTRICAL SHOCK HAZARDS. WHEN SERVICING IT IS ESSENTIAL THAT ONLY MANUFACTURERS SPECIFIED PARTS BE USED FOR THE CRITICAL COMPONENTS IN THE SCHEMATIC.

SECRET  
LGElectronics

LG ELECTRONICS

MODEL: W43 DUAL MSTAR  
POWER & WATER  
DATE: 2008-09-17  
SHEET: 2 / 2