



DISTINCT BY DESIGN™

## Owner's Manual

# MICROWAVE OVEN

Model: CVM721M

### Contents

<b>Safety Information</b> . . . . .	3	<b>Care And Cleaning</b> . . . . .	21
<b>Using the Microwave</b>		<b>Troubleshooting</b> . . . . .	23
Features . . . . .	6	<b>Optional Accessories</b> . . . . .	24
About the Features . . . . .	7	<b>Limited Warranty</b> . . . . .	25
Other Features . . . . .	15	<b>Consumer Support</b> . . . . .	26
WiFi Connect . . . . .	20		
Remote Enabled Equipment . . . . .	20		

Write the model and serial numbers here:

Model # \_\_\_\_\_

Serial # \_\_\_\_\_

You can find them on a label under the cooktop.

**English • Español**

## THANK YOU FOR MAKING CAFÉ A PART OF YOUR HOME.

---

We take pride in the craftsmanship, innovation and design that goes into every Café product, and we think you will too. Among other things, registration of your appliance ensures that we can deliver important product information and warranty details when you need them.

Register your Café appliance now online. Helpful websites are available in the Consumer Support section of this Owner's Manual. You may also mail in the pre-printed registration card included in the packing material.



# IMPORTANT SAFETY INSTRUCTIONS

## READ ALL INSTRUCTIONS BEFORE USING THE APPLIANCE

### **⚠ WARNING**

To reduce the risk of burns, electric shock, fire, injury to persons, or exposure to excessive microwave energy:

When using electrical appliances, basic safety precautions should be followed, including the following:

- Read all instructions before using this appliance.
- Read and follow the specific "PRECAUTIONS TO AVOID POSSIBLE EXPOSURE TO EXCESSIVE MICROWAVE ENERGY" found on page 5.
- Use this appliance only for its intended use as described in this manual. Do not use corrosive chemicals or vapors in this appliance. This microwave oven is specifically designed to heat, dry or cook food, and is not intended for laboratory or industrial use.
- This appliance should be serviced only by qualified service personnel. Contact nearest authorized service facility for examination, repair, or adjustment.

### **INSTALLATION**

- Install or locate this appliance only in accordance with the provided installation instructions.
- This appliance must be grounded. Connect only to a properly grounded outlet. See the "GROUNDING INSTRUCTIONS" found on page 5.
- This microwave oven is UL listed for installation over both gas and electric ranges.
- This unit is suitable for use above gas or electric cooking equipment, 36" or less wide.
- Do not operate this appliance if it has a damaged power cord or plug, if it is not working properly, or if it has been damaged or dropped.
- Keep power cord away from heated surfaces.
- Do not let cord hang over edge of table or counter.
- Do not immerse power cord or plug in water.
- Do not cover or block any opening on the appliance.
- Do not store this appliance outdoors. Do not use this product near water - for example, in a wet basement, near a swimming pool, or in a similar location.
- Do not mount over a sink.

### **TO REDUCE THE RISK OF FIRE IN THE CAVITY:**

- Do not overcook food. Carefully attend appliance when paper, plastic or other combustible materials are placed inside the oven while cooking.
- Remove wire twist-ties and metal handles from paper or plastic containers before placing them in the oven.
- If materials inside the oven ignite, keep the oven door closed, turn the oven off and disconnect the power cord, or shut off power at the fuse or circuit breaker panel.
- Do not store any materials in the oven when not in use. Do not leave paper products, cooking utensils, or food in the cavity when not in use.
- Do not operate the microwave feature without food in the oven.

### **TO REDUCE THE RISK OF BURNS**

- Be careful when opening containers of hot food. Use pot holders and direct steam away from face and hands.
- Vent, pierce, or slit containers, pouches or plastic bags to prevent build-up of pressure.
- Be careful when touching the turntable, door, or walls of the oven which may become hot during use.
- Liquids and certain foods heated in the microwave oven can present a risk of burn when removing them from the microwave. The potential for a burn is greater in young children, who should not be allowed to remove hot items from the microwave.

## READ AND SAVE THESE INSTRUCTIONS

# IMPORTANT SAFETY INSTRUCTIONS

## READ ALL INSTRUCTIONS BEFORE USING THE APPLIANCE

### **⚠ WARNING**

#### **OPERATING**

- As with any appliance, close supervision is necessary when used by children.
- Do not operate the oven without the turntable in place. The turntable must be unrestricted so it can turn.
- Make sure all cookware used in your microwave oven is suitable for microwaving. Most glass casseroles, cooking dishes, measuring cups, custard cups, pottery or china dinnerware which does not have metallic trim or glaze with a metallic sheen can be used in compliance with cookware manufacturers' recommendations.
- Do not store anything directly on top of the microwave surface when the microwave is in operation.
- Some products such as whole eggs and sealed containers - for example, closed jars - are able to explode and should not be heated in the microwave oven.
- Do not overcook potatoes. They could dehydrate and catch fire.
- Do not cover any other part of the oven with metal foil. This will cause overheating of the oven.
- Cook meat and poultry thoroughly—meat to at least an INTERNAL temperature of 160°F and poultry to at least an INTERNAL temperature of 180°F. Cooking to these temperatures usually protects against foodborne illness.
- This oven is not approved or tested for marine use.

#### **CLEANING**

- Keep the oven free from grease buildup.
- Do not clean with metal scouring pads. Pieces can burn off the pad and touch electrical parts involving risk of electric shock.
- When cleaning surfaces of door and oven that come together on closing the door, use only mild, nonabrasive soaps, or detergents applied with a clean sponge or soft cloth. Rinse well.

#### **SUPER HEATED WATER**

- Liquids, such as water, coffee, or tea, are able to be overheated beyond the boiling point without appearing to be boiling. Visible bubbling or boiling when the container is removed from the microwave oven is not always present. **THIS COULD RESULT IN VERY HOT LIQUIDS SUDDENLY BOILING OVER WHEN THE CONTAINER IS DISTURBED OR A SPOON OR OTHER UTENSIL IS INSERTED INTO THE LIQUID.**
- To reduce the risk of injury to persons:
  - Do not overheat the liquid.
  - Stir the liquid both before and halfway through heating it.
  - Do not use straight-sided containers with narrow necks.
  - After heating, allow the container to stand in the microwave oven for a short time before removing the container.
  - Use extreme care when inserting a spoon or other utensil into the container.

**READ AND SAVE THESE INSTRUCTIONS**

# IMPORTANT SAFETY INSTRUCTIONS

## READ ALL INSTRUCTIONS BEFORE USING THE APPLIANCE

### PRECAUTIONS TO AVOID POSSIBLE EXPOSURE TO EXCESSIVE MICROWAVE ENERGY

- (a) **Do Not Attempt** to operate this oven with the door open since open-door operation can result in harmful exposure to microwave energy. It is important not to defeat or tamper with the safety interlocks.
- (b) **Do Not Place** any object between the oven front face and the door or allow soil or cleaner residue to accumulate on sealing surfaces.
- (c) **Do Not Operate** the oven if it is damaged. It is particularly important that the oven door close properly and that there is no damage to the:
- (1) door (bent),
  - (2) hinges and latches (broken or loosened),
  - (3) door seals and sealing surfaces.
- (d) **The Oven Should Not** be adjusted or repaired by anyone except properly qualified service personnel.

### GROUNDING INSTRUCTIONS

#### ⚠ WARNING

Improper use of the grounding plug can result in a risk of electric shock.

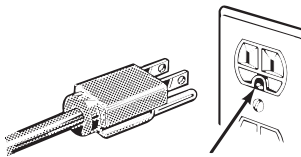

Ensure proper ground exists before use.

This appliance must be grounded. In the event of an electrical short circuit, grounding reduces the risk of electric shock by providing an escape wire for the electric current.

This appliance is equipped

with a power cord having a grounding wire with a grounding plug. The plug must be plugged into an outlet that is properly installed and grounded.

Consult a qualified electrician or service technician if the **GROUNDING INSTRUCTIONS** are not completely understood, or if doubt exists as to whether the appliance is properly grounded.

If the outlet is a standard 2-prong wall outlet, it is your personal responsibility and obligation to have it replaced with a properly grounded 3-prong wall outlet.

Do not under any circumstances cut or remove the third (ground) prong from the power cord.

Do not use an extension cord. If the power cord is too short, have a qualified electrician or service technician install an outlet near the appliance.

For best operation, plug this appliance into its own electrical outlet to prevent flickering of lights, blowing of fuse or tripping of circuit breaker.

#### NOTICE: PACEMAKERS

Most pacemakers are shielded from interference from electronic products, including microwaves. However, patients with pacemakers may wish to consult their physicians if they have concerns.

#### VENT FAN

#### ⚠ WARNING

The fan will operate automatically under certain conditions. Take care to prevent the starting and spreading of accidental cooking fires while the vent fan is in use.

- Clean the underside of the microwave often. Do not allow grease to build up on the microwave or the fan filters.
- In the event of a grease fire on the surface units below the microwave oven, smother a flaming pan on the surface unit by covering the pan completely with a lid, a cookie sheet or a flat tray.
- Use care when cleaning the vent fan filters. Corrosive cleaning agents, such as lye-based oven cleaners, may damage the filters.
- When preparing flaming foods under the microwave, turn the fan on.
- Never leave surface units beneath your microwave oven unattended at high heat settings. Boilovers cause smoking and greasy spillovers that may ignite and spread if the microwave vent fan is operating. To minimize automatic fan operation, use adequate sized cookware and use high heat on surface units only when necessary.

## READ AND SAVE THESE INSTRUCTIONS

## Features

Throughout this manual, features and appearance may vary from your model.

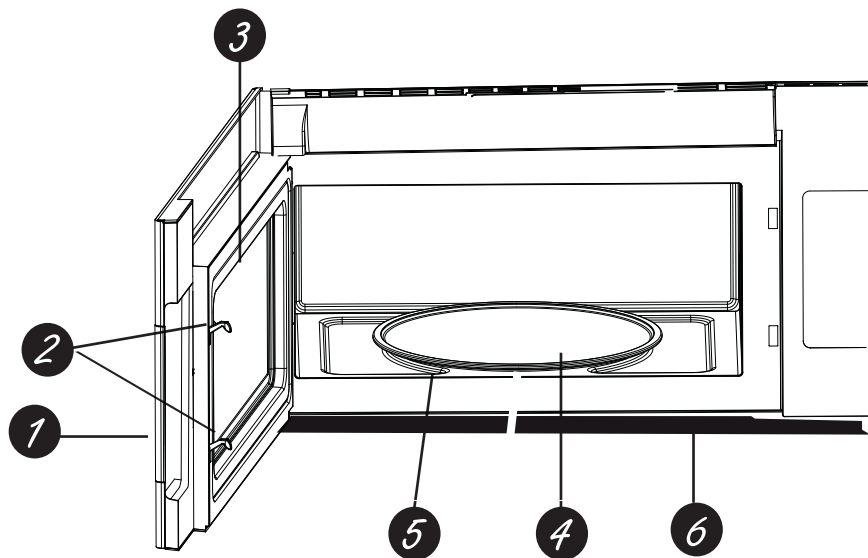

**1. Door Handle**

**2. Door Latches**

**3. Window with Metal Shield**

Screen allows cooking to be viewed while keeping microwaves confined in the oven.

**4. Removable Turntable**

Do not operate the oven in the microwave mode without the turntable and turntable support seated and in place.

**5. Removable Turntable Support**

Do not operate the oven in the microwave mode without the turntable and turntable support seated and in place.

**6. Deflector.** Provides robustness from cooktop heat.

Do not remove.

**NOTE:** Oven vent(s) and oven light are located on the inside walls of the microwave oven.

## Accessories

Bump-Out Kits

JX15BUMPWW—White

JX15BUMPBB—Black

# About the features

## Cooking Controls

1 Express Cook

1	2	3	4	5	Cook Time	Power Level	Add 30 Sec	Start/Pause
6	7	8	9	0	Timer On/Off	Vent Fan	Surface Light	Cancel Off

2 Sensor Cooking

Auto Cook	Reheat	Defrost	Steam Clean	Settings	Chef Connect
Steam Cook	Potato	Popcorn	Reset Filter	Lock Control	WiFi Connect
			Hold 3 Sec	Hold 3 Sec	Hold 3 Sec

Check the Convenience Guide before you begin.

1 Time Features

Press	Enter
COOK TIME	Amount of cooking time
DEFROST	Weight or time
TIMER	
POWER LEVEL	Power level 1 to 10
ADD 30 SEC	Starts immediately!
EXPRESS COOK	Starts immediately!

2 Sensor/Convenience Features

Press	Enter
AUTO COOK	Press pad to select food
POPCORN	Start immediately
REHEAT	Press pad to select food
POTATO	Start immediately
STEAM COOK	Press pad to select food

# About the features

## Cook Time

Allows you to microwave for any time up to 99 minutes and 99 seconds.

**Power level 10 (HIGH)** is automatically set, but you may change it for more flexibility.

1. Press **Cook Time**.
2. Enter cooking time.
3. Press **START**.

Cooking will start when the countdown begins in the display.

You may open the door during **Cook Time** to check the food. Close the door and press **START** to resume cooking.

Cook Time

Express Cook



Start  
Pause

## Express Cook

This is a quick way to set cooking time for 1-5 minutes.

1. Press one of the **Express Cook** pads (from 1-5) for 1-5 minutes of cooking at **power level 10**.  
For example, press the **2** pad for 2 minutes of cooking time.

The power level can be changed as time is counting down. Press **POWER LEVEL** and enter 1-10.

**NOTE: Express Cook function pertains to pads 1-5 only.**

Express Cook



## Add 30 Sec

This will add 30 seconds to the time counting down each time the pad is pressed. Each touch will add 30 seconds, up to 99 minutes and 99 seconds.

**Add 30 sec** can also be used like an express 30 seconds button. The microwave oven will start immediately when pressed.

Add  
30 Sec

## Weight Defrost

Use **Weight Defrost** for meat, poultry and fish. Use **Time Defrost** for most other frozen foods. (Time Defrost is explained on page 9.)

1. Press **DEFROST** once for **Weight Defrost**.
2. Enter the weight in pounds.
3. Press **START**.

Cooking will start when the countdown begins in the display.

Defrost

Express Cook



Start  
Pause

## Defrosting Tips

- Remove meat from package and place on microwave-safe dish.
- When the oven signals, turn the food over. Remove defrosted meat or shield warm areas with small pieces of foil.
- After defrosting, most meats need to stand 5 minutes to complete defrosting. Large roasts should stand for about 30 minutes.

## Conversion Guide

If the weight of food is stated in pounds and ounces, the ounces must be converted to tenths (.1) of a pound.	
Ounces	Pounds
1-2	.1
3	.2
4-5	.3
6-7	.4
8	.5
9-10	.6
11	.7
12-13	.8
14-15	.9



# About the features

## Time Defrost

Allows you to defrost for a selected length of time. See the Defrosting Guide on page 14 for suggested times (**Weight Defrost** is explained on page 8).

1. Press **DEFROST** twice for **Time Defrost**.
2. Enter defrosting time in minutes and seconds.
3. Press **START**.  
Cooking will start when the countdown begins in the display.

At one half of selected defrosting time, turn food over and break apart or rearrange pieces for more even defrosting. Shield any warm areas with small pieces of foil. The oven will continue to defrost if you don't open the door and turn the food.

Noises may be heard during defrosting. This is normal when oven is not operating at **High** power.

## Defrosting Tips

- Foods frozen in paper or plastic can be defrosted in the package. Closed packages should be slit, pierced or vented **AFTER** food has partially defrosted. Plastic storage containers should be partially uncovered.
- Family-size, prepackaged frozen dinners can be defrosted and microwaved. If the food is in a foil container, transfer it to a microwave-safe dish.
- Foods that spoil easily should not be allowed to sit out for more than one hour after defrosting. Room temperature promotes the growth of harmful bacteria.
- For more even defrosting of larger foods, such as roasts, use **Time Defrost**. Be sure large meats are completely defrosted before cooking.
- When defrosted, food should be cool but softened in all areas. If still slightly icy, return to the microwave very briefly, or let it stand a few minutes.



## About the features

Defrosting Guide		
Food	Time	Comments
<b>Breads, Cakes</b>		
Bread, buns or rolls (1 piece)	1/4 min.	
Sweet rolls (approx. 12 oz.)	2 to 4 min.	Rearrange after half of time.
<b>Fish and Seafood</b>		
Fillet, frozen (1 lb.)	6 to 9 min.	
<b>Fruit</b>		
Plastic pouch—1 or 2 (10-oz. package)	1 to 5 min.	
<b>Meat</b>		
Bacon (1 lb.)	2 to 5 min.	Place unopened package in oven. Let stand 5 minutes after defrosting.
Franks (1 lb.)	2 to 5 min.	Place unopened package in oven. Microwave just until franks can be separated. Let stand 5 minutes, if necessary, to complete defrosting.
Ground meat (1 lb.)	4 to 6 min.	Turn meat over after first half of time.
Roast: beef, lamb, veal, pork	9 to 13 min. per lb.	Use power level 10.
Steaks, chops and cutlets	4 to 8 min. per lb.	Place unwrapped meat in cooking dish. Turn over after first half of time and shield warm areas with foil. After second half of time, separate pieces with table knife. Let stand to complete defrosting.
<b>Poultry</b>		
Chicken, broiler-fryer, cut up (2 1/2 to 3 lbs.)	14 to 20 min.	Place wrapped chicken in dish. Unwrap and turn over after first half of time. After second half of time, separate pieces and place in cooking dish. Microwave 2 to 4 minutes more, if necessary. Let stand a few minutes to finish defrosting.
Chicken, whole (2 1/2 to 3 lbs.)	20 to 25 min.	Place wrapped chicken in dish. After first half of time, unwrap and turn chicken over. Shield warm areas with foil. To complete defrosting, run cool water in cavity until giblets can be removed.
Cornish hen	7 to 13 min. per lb.	Place unwrapped hen in oven breast-side-up. Turn over after first half of time. Run cool water in cavity until giblets can be removed.
Turkey breast (4 to 6 lbs.)	3 to 8 min. per lb.	Place unwrapped breast in microwave-safe dish breast-side-down. After first half of time, turn breast-side-up and shield warm areas with foil. Defrost for second half of time. Let stand 1 to 2 hours in refrigerator to complete defrosting.

# About the features

The Sensor Features detect the increasing humidity released during cooking. The oven automatically adjust the cooking time to various types and amounts of food.

Do not use the Sensor Features twice in succession on the same food portion - It may result in severely overcooked or burnt food. Be sure to let the oven cool down for 5 - 10 minutes before starting the next sensor cook.

If food is undercooked after the countdown, use Cook Time for additional cooking time

- The proper containers and covers are essential for best sensor cooking.
- **Always use microwave-safe containers and cover them with lids or vented plastic wrap. Never use tight-sealing plastic covers** - they can prevent steam from escaping and cause food to overcook.
- **Be sure the outside of the cooking container and the inside of the microwave oven are dry** before placing food in the oven. Beads of moisture turning into steam can mislead the sensor.

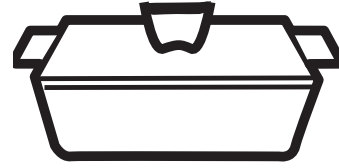

Covered



Vented



Dry off dishes so they don't mislead the sensor.

## How to Change the Automatic Settings

### To reduce time by 10%:

Press 1 after the feature pad.

### To add 10% to cooking time:

Press 9 after the feature pad.

## Auto Cook

Allows you to microwave food choices with sensor.

1. Press **AUTO COOK** button.
2. Enter the food type code. See Cooking Guide for AUTO COOK below for codes or check the display for food types..

### 2. Press **START**.

The oven signals when steam is sensed and the time remaining begins counting down.

Do not open the oven door until time is counting down. If the door is opened before time is counting down 4 beeps are emitted while the display will Scroll & Cycle "SENSOR ERROR " until **CANCEL** is pressed. The sensor cook will be cancelled as well. If the Door is opened during the counting down, close it and press **START** immediately.

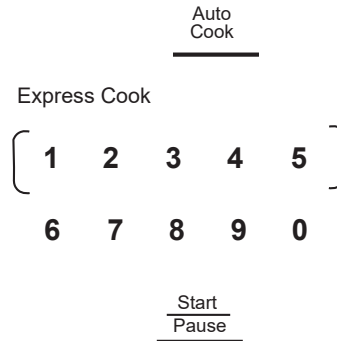

### Cooking Guide for Auto Cook Feature

CODE ENTRY	FOOD	COMMENTS
1	Chicken	
2	Fish	
3	Ground Meat	
4	Veggies	Enter veggies type 1 Fresh Veggies 2 Frozen Veggies 3 Canned Veggies

# About the features

---

## Popcorn

To use the **Popcorn** feature:

1. Place the package of popcorn in the center of the microwave.
2. Press **POPCORN**. The oven starts immediately.  
 Your popcorn bag may get stuck and stop rotating, but this will not affect the cooking performance. Do not open the door even if the bag is not rotating.  
 Using the vent function in combination with the popcorn sensor feature may lead to over cooking.

## Popcorn

---

### How to Change the Automatic Settings

#### To reduce time by 10%:

Press 1 after the feature pad.

#### To add 10% to cooking time:

Press 9 after the feature pad.

If food is undercooked after the countdown, use **Cook Time** for additional cooking time. We recommend 30 seconds and watch carefully.

## Reheat

The **Reheat** feature reheats servings of previously cooked foods or a plate of leftovers.

1. Press **REHEAT**.
2. Using the cooking guide below, enter food code. For example, **1** for Pasta.
3. Press **START/PAUSE**. The oven signals when steam is sensed and the time remaining begins counting down.

Do not open the oven door until time is counting down. If the door is opened before time is counting down 4 beeps are emitted while the display will Scroll & Cycle "SENSOR ERROR " until **CANCEL** is pressed. The sensor cook will be cancelled as well. If the Door is opened during the counting down, close it and press **START** immediately.

## Reheat

---

**After removing food from the oven, stir, if possible, to even out the temperature. If the food is not hot enough, use Cook Time to reheat for more time. Reheated foods may have wide variations in temperature. Some areas may be extremely hot.**

It is best to use **Cook Time** for these foods:

- Bread products.
- Foods that must be reheated covered.
- Foods that need to be stirred or rotated during reheating.
- Foods calling for a dry look or crisp surface after reheating.

### How to Change the Automatic Settings

#### To reduce time by 10%:

Press 1 after the feature pad.

#### To add 10% to cooking time:

Press 9 after the feature pad.

#### Cooking Guide for Reheat Feature:

Code Entry	Food
1	Pasta
2	Pizza
3	Plate
4	Soup

## Potato

To use the **Potato** feature:

1. Place the potato in the center of the microwave.
2. Press **POTATO**.

The oven starts immediately.

Do not open the oven door until time is counting down. If the door is opened before time is counting down 4 beeps are emitted while the display will Scroll & Cycle "SENSOR ERROR " until **CANCEL** is pressed. The sensor cook will be cancelled as well. If the Door is opened during the counting down, close it and press **START** immediately.

## Potato

---

### How to Change the Automatic Settings

#### To reduce time by 10%:

Press 1 after the feature pad.

#### To add 10% to cooking time:

Press 9 after the feature pad.

# About the features

## Microwave Terms

Term	Definition
<b>Arcing</b>	Arcing is the microwave term for sparks in the oven. Arcing is caused by: <ul style="list-style-type: none"> <li>• metal or foil touching the side of the oven.</li> <li>• foil that is not molded to food (upturned edges act like antennas).</li> <li>• metal such as twist-ties, poultry pins, gold-rimmed dishes.</li> <li>• recycled paper towels containing small metal pieces.</li> </ul>
<b>Covering</b>	Covers hold in moisture, allow for more even heating and reduce cooking time. Venting plastic wrap or covering with wax paper allows excess steam to escape.
<b>Shielding</b>	In a regular oven, you shield chicken breasts or baked foods to prevent over-browning. When microwaving, you use small strips of foil to shield thin parts, such as the tips of wings and legs on poultry, which would cook before larger parts.
<b>Standing Time</b>	When you cook with regular ovens, foods such as roasts or cakes are allowed to stand to finish cooking or to set. Standing time is especially important in microwave cooking. Note that a microwaved cake is not placed on a cooling rack.
<b>Venting</b>	After covering a dish with plastic wrap, vent the plastic wrap by turning back one corner so excess steam can escape.

## Steam Cook

Use the **Steam Cook** feature to steam certain preprogrammed foods.

1. Press **Steam Cook** button.
2. Enter the food type code you wish to Steam Cook. See Cooking Guide for Steam Cook below for codes or check the display for food types.
3. Place steamer bowl with water, salt (if necessary), and food in the microwave with the steam vents on the steamer bowl in the OPEN position.
4. Press **START** button to begin cooking.

**NOTE:** The NordicWare Rice Cooker/Steamer Bowl should be used for best cooking results.

## Cooking Guide for Steam Cook Feature

Code Entry	Food	Amount Entry
1	Rice	1 - 1 cup white 2 - 1 cup brown
2	Asparagus	1 - 1 cup 2 - 2 cups
3	Broccoli	1 - 1 cup 2 - 2 cups
4	Brussel Sprouts	1 - 1 cup 2 - 2 cups
5	Carrots	1 - 1 cup 2 - 2 cups
6	Cauliflower	1 - 1 cup 2 - 2 cups
7	Zucchini	1 - 1 cup 2 - 2 cups

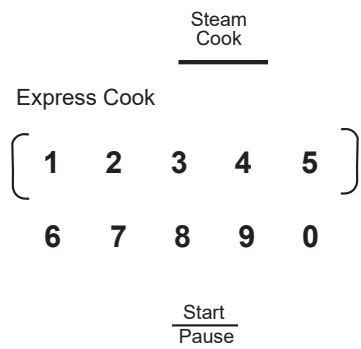

# About the features

## Changing the Power Level

The power level may be entered or changed before or during cooking. **Power Level** is set for Level 10 (High) unless it is changed.

1. Press **Power Level** button.
2. Enter new power level by using the number pads or press the **Power Level** button multiple times until you find the level you want.
3. After you have selected the power level, wait five seconds. The display will go back to the **Cook Time** screen.
4. Enter cooking time and press **START**.

**OR**

1. Press **Cook Time** button.
2. Enter your cooking time.
3. Press **Power Level** button.
4. Enter new power level by using the number pads or press the **Power Level** button multiple times until you find the level you want.
5. After you have selected the power level, wait five seconds. The display will go back to the **Cook Time (Enter Time)** screen.
6. Press **START**.

Variable power levels add flexibility to microwave cooking. The power levels on the microwave oven can be compared to the surface units on a range. Each power level gives you microwave energy a certain percent of the time. **Power level 7** is microwave energy 70% of the time. **Power level 3** is energy 30% of the time. Most cooking will be done on High (power level 10) which gives you 100% power. **Power level 10** will cook faster but food may need more frequent stirring, rotating or turning over. A lower setting will cook more evenly and need less stirring or rotating of the food. Some foods may have better flavor, texture or appearance if one of the lower settings is used. Use a lower power level when cooking foods that have a tendency to boil over, such as scalloped potatoes and some casseroles.

Rest periods (when the microwave energy cycles off) give time for the food to “equalize” or transfer heat to the inside of the food. An example of this is shown with **Power level 3**—the defrost cycle. If microwave energy did not cycle off, the outside of the food would cook before the inside was defrosted.

Here are some examples of uses for various power levels:

**High 10 (100%):** Fish, bacon, vegetables, boiling liquids.

**Med-High 7 (70%):** Gentle cooking of meat and poultry; baking casseroles and reheating.

**Medium 5 (50%):** Slow cooking and tenderizing for stews and less tender cuts of meat.

**Low 2 or 3 (20 or 30%):** Defrosting; simmering; delicate sauces.

**Warm 1 (10%):** Keeping food warm; softening butter.

**NOTE:** You can also change the power level during many cooking modes by pressing the power level button entering a valid power level.

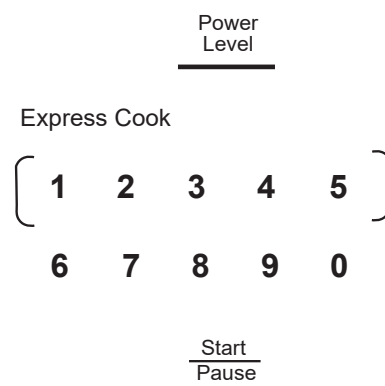

# Other Features

---

## Start/Pause

In addition to starting many functions, **START/PAUSE** allows you to stop cooking without opening the door or clearing the display and resume cooking later.

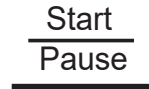

---

## Cancel/Off

Press the **CANCEL/OFF** button to stop and cancel cooking at any time.



---

## Control Lock-Out

You may lock the control panel to prevent the oven from being accidentally started during cleaning or being used by children.

To lock or unlock the controls, press and hold the **LOCK CONTROL** button for three seconds. When the control panel is locked, LOCKED will be displayed briefly anytime a button or dial is pressed. "L" will show in the display.



---

## Surface Light

Press **SURFACE LIGHT** once for low light, twice for high light or a third time to turn the light off.

**Note:** If the microwave is working and the vent fan is on Boost speed, the surface lights will be turned to low light automatically.



---

## Timer

**NOTE:** The **Timer** indicator will be lit while the timer is operating.

The **Timer** operates as a minute timer and can be used at any time, even when the oven is operating.

1. Press the **Timer** button.
2. Enter a time.
3. Press the **Timer** button to start.

To cancel, press the **Timer** button.

When time is up, the oven will signal.  
To turn off the timer signal, press **Timer**.

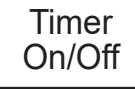

## Other Features

---

### Steam Clean

1. Press the **Steam Clean** button.
2. Put steam bowl with 1/4 cup of water.
3. Press the dial or **Start/Pause** to start.

Once the cycle is terminated, wipe oven cavity with paper towel or cloth.

Steam  
Clean

---

### Display

If you have the Timer counting down and you are using the Cook Time at the same time, you can change the display to show either the timer or the cook time countdown.

If the display shows the time for the Timer and you would like to view the Cook Time, press the **COOK TIME** button.



If the display shows the time for the Cook Time and you would like to view the Timer, press the **TIMER** button

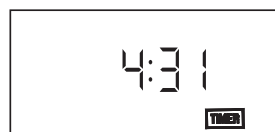

### WiFi Connect

Empowers you to remotely monitor and control your microwave oven using your smart phone or tablet. For example, you could view the current status of the microwave or turn it on and off. To get started, download and open the Café Appliances Kitchen App using your smart device. To enable this feature, follow the instructions provided in the app. To disable this feature and remove the microwave from the WiFi network, press and hold the WiFi Connect button for 3 seconds. You

have successfully disabled this feature when the WiFi icon in the display is no longer illuminated. For further instructions, visit our website at [cafeappliances.com/connect](http://cafeappliances.com/connect).

WiFi  
Connect  
— Hold 3 Sec —

### Vent Fan

The vent fan removes steam and other vapors from surface cooking.

Press **Vent Fan** once for low fan speed, twice for medium fan speed, three times for high fan speed, four times for boost speed or five times to turn the fan off

### Automatic Fan

An automatic fan feature protects the microwave from too much heat rising from the cooktop below it. It automatically turns on if it senses too much heat.

If you have turned the fan on you may find that you cannot turn it off. The fan will automatically turn off when the internal parts are cool. It may stay on for 30 minutes or more after the cooktop and microwave controls are turned off.

Vent  
Fan

---

### Insert Food Reminder

A reminder will show on the display if the user tries to start the cooking cycle without placing food inside the microwave oven within 5 minutes prior to starting the cooking cycle.

### Cooking Complete Reminder

To remind you that you have food in the oven, the oven will display "Food is ready" and beep once a minute until you either open the oven door or press the **CANCEL/OFF** button.



# Other Features

## Settings

Settings allow to change the default settings of your OTR.

1. Press the Settings pad. "SELECT SETTING ITEM"

- 1- CLOCK SETTING
- 2- CLOCK MODE
- 3- BEEPER VOLUME
- 4- LIGHT SYNC
- 5- VENT FAN SYNC
- 6- SYNC SUTO OFF

- 7- TURN TABLE
- 8- DISPLAY SETTING
- 9- REMOTE ENABLE
- 0- EXIT

2. Select the item to change the settings. See below tables for detail Guide

## Settings



Code Entry	Items for setting	Level Entry
1	CLOCK Setting	Entry valid number for setting clock time
2	Clock Mode	0 - 12 hours 1 - 24 hours Default is 12 hours
3	Beeper Volume	0 - Mute 1 - Low 2 - Normal 3 - Loud Default is normal
4	Chef Connect Feature: Light Sync - Selects the light level at which the surface lights will automatically turn on when paired range's burner is turned on. Select "Off" to disable this feature. Surface light will turn on manually.	0 - Off 1 - Low 2 - High Default is High
5	Chef Connect Feature: Vent Fan Sync - Selects the fan speed at which the vent fan will automatically turn on when paired range's burner is turned on. Select "Off" to disable this feature. Vent fan will turn on manually.	0 - Off 1 - Low 2 - Medium 3 - High 4 - Boost Default is OFF
6	Chef Connect Feature: Sync Auto Off - When the Light/Vent fan sync mode is enabled (ON), this will automatically turn OFF the light/fan when the range burner has been turned off. Select the period of time the light/fan will remain on until the microwave automatically turns it off.	0 - 0 minutes 1 - 5 minutes 2 - 10 minutes 3 - 15 minutes 4 - Manual Default is 15 minutes
7	Turntable On/Off	0 - OFF 1 - ON default setting is ON"
8	Display Setting	DISPLAY: 1 - DISPLAY ON/OFF : 0 - OFF 1 - ON 2 - SCROLL SPEED : 1 - SLOW 2 - NORMAL 3 - FAST 3 - SLEEP DELAY: 1 - 5 SEC 2 - 10 SEC 3 - 30 SEC
9	Remote Enable: Remote Enable On/Off feature could enable you to start the microwave from a remote source or avoid you unintendedly to control your microwave remotely. For turn on/off this feature please press "Settings" button on the control panel then press "9" to select this feature then press "1" for On and "0" for Off function.	0-OFF 1-ON Default is On
0	Setting Exit	0 - EXIT

## Other Features

---

### Chef Connect

Use the Chef Connect feature for connecting your microwave to a GE Appliances range to sync your vent fan, cooktop surface lights and clock via Bluetooth technology.

1. You must have a Chef Connect enabled range. To pair your microwave for the first time, initiate the Chef Connect process on the GE Appliances range. Refer to the range owner's manual for instructions
2. On the microwave, hold Chef Connect button for 3 seconds. The Bluetooth icon  on the display will start flashing as the microwave starts to search and pair with your GE Appliances range. The icon  will remain ON after pairing successfully.

If a GE Appliances range is not found within 2 minutes during search mode the microwave will stop searching and the Bluetooth icon  will turn OFF.

On initial setup, the setup protocol will start.

If the Chef Connect feature is enabled the default settings are as follows:

- Display clock sync: ON
- Auto cooktop light: ON (HIGH setting)
- Auto vent fan: OFF
- Auto off: 15 minutes

3. Select 1 to sync the surface lights to your GE Appliances range. It allows the microwave surface lights to turn on at HIGH level automatically when the paired range's cooktop burner turns on.

4. Select 1 to sync the vent fan to your GE Appliances range. This allows the microwave vent fan to turn on at LOW speed automatically when the paired range's cooktop burner turns on.

Pairing is now complete, the Chef Connect feature is now on.

**NOTE:** If there is no sync option selected during set up, 5 minutes after icon  turns on, the units will return to stand-by mode.

After completing the setting per above steps, your microwaves vent fan and cooktop light will be set to turn on automatically when the cooktop burner is turned on. The cooktop and range clock display will be synced to display the same time. The vent fan and cooktop light will be set to automatically turn off 15 minutes after the cooktop burner is turned off.

If desired, the light, fan, and auto off settings can now be changed using settings options 4, 5, and 6, respectively.

Press Chef Connect once to turn off and twice to re-connect. The icon  will illuminate when on.

In the case of an unintended disconnect such as lost power to the microwave or range the connection will remain after power resumed. For very short power interruptions, the power may need to be reset in order to reconnect

**Chef  
Connect**

---

Hold 3 Sec

# Other Features

---

## Reset Filter

The red LED indicator will light every 6 months as a reminder to replace the charcoal filter.

After replacing the charcoal filters, Hold the **Rest Filter** for 3 seconds to turn off the Red LED indicator.

Reset  
Filter

Hold 3 Sec

---

## Charcoal Filter

The charcoal filter cannot be cleaned. It must be replaced. See back cover for ordering online at [cafeappliances.com](http://cafeappliances.com)

If the model is not vented to the outside, the air will be recirculated through a disposable charcoal filter that helps remove smoke and odors.

The charcoal filter should be replaced when it is noticeably dirty or discolored (usually after 6 to 12 months, depending on usage). See **Optional Kits** page 30, for more information.

## CHARCOAL FILTER REPLACEMENT

1. **Unplug** the microwave oven.
2. **Remove** the vent grille mounting screws.
3. **Tip** the grille forward, then **lift out** to remove.
4. **Remove** the charcoal filter.
5. **Slide a new charcoal filter into place.**
6. **Slide** the bottom of the vent grille into place. **Push** the top until it snaps into place. **Replace** the mounting screws
7. **Plug** in the microwave oven.

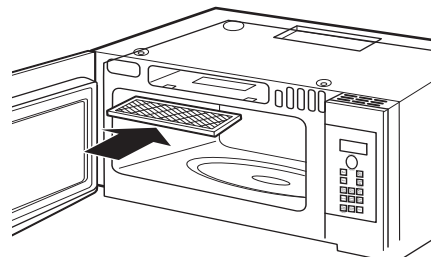

# WiFi Connect

## Connecting your WiFi Connect enabled microwave oven (on some models)

Your Café Appliances microwave oven is designed to provide you with two-way communication between your appliance and smart device. By using the Café Appliances WiFi Connect features, you will be able to control essential operations such as turning on and off your microwave, convenience features, cook time, timers using your smartphone, tablet or voice control device.

**What you will need:**

1. Know the password of your home WiFi router.
2. Download the Café Appliances Kitchen App to your smart device.
3. Follow the app on-screen instructions to connect your Café microwave.



For further instructions, visit:  
[cafeappliances.com/connect](http://cafeappliances.com/connect).

## Remote Enable On/Off Feature

Remote Enable is a feature that allows you to start the microwave from a remote source such as the Cafe Appliances Kitchen App or Voice Commands from Amazon Alexa or Google Assistant.

To turn this feature on/off select the Settings button on the control panel and then press “9” to select this feature. Press “1” for Remote Enable On and “0” for Remote Enable Off.

When the Remote Enable feature is off, you will still receive messages from your microwave, you can turn off the microwave, or you can use the timer and clock from your smart device.

### Settings

When the Remote Enable feature is on, you need to have opened the microwave door within the last 5 minutes. The 5 minute restriction is to help ensure food is in the microwave before starting the cooking cycle.

## Remote Enable Equipment

This device complies with part 15 of the FCC Rules. Operation is subject to the following two conditions: (1) This device may not cause harmful interference, and (2) this device must accept any interference received, including interference that may cause undesired operation.

The wireless communication equipment installed on this microwave has been tested and found to comply with the limits for a Class B digital device, pursuant to part 15 of the FCC Rules. These limits are designed to:

(a) provide reasonable protection against harmful interference in a residential installation. This equipment generates, uses, and can radiate radio frequency energy and, if not installed and used in accordance with the instructions, may cause harmful interference to radio communications. However, there is no guarantee that interference will not occur in a particular installation. If this equipment does cause harmful interference to radio or television reception, which can be determined by turning the equipment off and on, the user is encouraged to try to correct the interference by one or more of the following measures:

- Connect the equipment into an outlet on a circuit different from that to which the receiver is connected.
- Consult the dealer or an experienced radio/TV technician for help.

(b) accept any interference received, including interference that may cause undesired operation of the device.

- Reorient or relocate the receiving antenna.
- Increase the separation between the equipment and receiver.

**NOTE:** Any changes or modifications to the wireless communication device installed on this oven that are not expressly approved by the manufacturer could void the user’s authority to operate the equipment.

RF Exposure - This device is only authorized for use in a mobile application. At least 20 cm of separation distance between the transmitting antenna device and the user’s body must be maintained at all times.

# Care and Cleaning

## Helpful Hints

An occasional thorough wiping with a solution of baking soda and water keeps the inside fresh.

**Be certain the oven control is turned off before cleaning any part of this oven.**



## How to Clean the Inside

### Walls, Floor, Inside Window, Metal and Plastic Parts on the Door

Some spatters can be removed with a paper towel; others may require a damp cloth. Remove greasy spatters with a sudsy cloth, then rinse with a damp cloth. Do not use abrasive cleaners or sharp utensils on oven walls.

To clean the surface of the door and the surface of the oven that come together upon closing, use only mild, nonabrasive soaps or detergents using a sponge or soft cloth. Rinse with a damp cloth and dry.

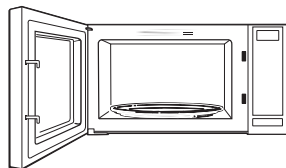

Never use a commercial oven cleaner on any part of your microwave.

### Removable Turntable and Turntable Support

To prevent breakage, do not place the turntable into water just after cooking. Wash it carefully in warm, sudsy water or in the dishwasher. The turntable and support can be broken if dropped. Remember, do not operate the oven in the microwave mode without the turntable and support seated and in place.

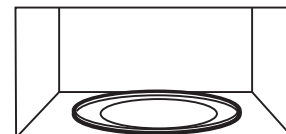

## How to Clean the Outside

Do not use cleaners containing ammonia or alcohol on the microwave oven. Ammonia or alcohol can damage the appearance of the microwave.

### Case

Clean the outside of the microwave with a sudsy cloth. Rinse with a damp cloth and then dry. Wipe the window clean with a damp cloth.

### Control Panel and Door

Wipe with a damp cloth. Dry thoroughly. Do not use cleaning sprays, large amounts of soap and water, abrasives or sharp objects on the panel—they can damage it. Some paper towels can also scratch the control panel.

### Door Surface

It is important to keep the area clean where the door seals against the microwave. Use only mild, non-abrasive detergents applied with a clean sponge or soft cloth. Rinse well.

### Power Cord

If the cord becomes soiled, unplug and wash with a damp cloth. For stubborn spots, sudsy water may be used, but be certain to rinse with a damp cloth and dry thoroughly before plugging cord into outlet.

### Stainless Steel (on some models)

Do not use a steel-wood pad; it will scratch the surface.

To clean the stainless steel surface, use a hot, damp cloth with a mild detergent suitable for stainless steel surfaces. Use a clean, hot, damp cloth to remove soap. Dry with a dry, clean cloth. Always scrub lightly in the direction of the grain.

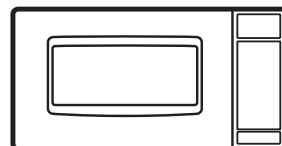

# Care and Cleaning

## Removing and Cleaning the Filters

To **remove**, slide them to the rear using the tabs. Pull down and out.

To clean the vent filters, soak them and then swish around in hot water and detergent. Don't use ammonia or ammonia products because they will darken the metal. Light brushing can be used to remove embedded dirt.

Rinse, shake and let dry before replacing.

To **replace**, slide the filters into the frame slots on the back of each opening. Press up and to the front to lock into place.

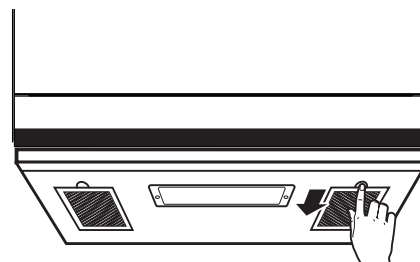

## Cooktop Light/Nite Light

Replace with LED lamp. See back cover for ordering online at [cafeappliances.com](http://cafeappliances.com).

1. To replace the cooktop light/nite light, first disconnect the power at the main fuse or circuit breaker panel, or pull the plug.
2. Remove the screw from the side of the light compartment cover and lower the cover until it stops.
3. Be sure the LED lamp is cool before removing. Remove a screw and connector from LED lamp.
4. Connect LED lamp and secure using the screw. Raise the light cover and replace the screw. Connect electrical power to the oven.



Remove screw.

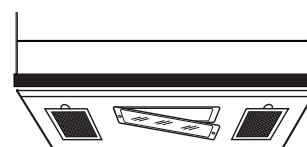

## Replacing the Oven Cavity Light

1. Disconnect power at the main fuse or circuit breaker panel.
2. Press the charcoal access door at the top to open.
3. Remove charcoal filter if present. NOTE: Charcoal filter is an optional kit, you may not have one.
4. Press the retainer holding the lamp shield in place.
5. Pull the lamp shield out. Unscrew the LED light out and replace with the new LED board. Order **LED board** from your Café supplier.
6. Return the lamp and lamp shield to original position and replace charcoal filter.
7. Replace the grill and 2 screws. Reconnect power to the oven.

## Vent Fan

The vent fan has two metal reusable vent filters.

Models that recirculate air back into the room also use a charcoal filter.

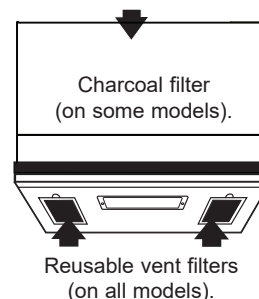

## Reusable Vent Filters

The metal filters trap grease released by foods on the cooktop. They also prevent flames from foods on the cooktop from damaging the inside of the oven.

For this reason, the filters must always be in place when the hood is used. The vent filters should be cleaned once a month, or as needed.

# Troubleshooting Tips

## Things That Are Normal With Your Microwave Oven

- Steam or vapor escaping from around the door.
- Light reflection around door or outer case.
- Dimming oven light and change in the blower sound at power levels other than high.
- Dull thumping sound while oven is operating.
- TV-radio interference might be noticed while using the microwave. Similar to the interference caused by other small appliances, it does not indicate a problem with the microwave. Plug the microwave into a different electrical circuit, move the radio or TV as far away from the microwave as possible or check the position and signal of the TV/radio antenna.

## FEDERAL COMMUNICATIONS COMMISSION RADIO FREQUENCY INTERFERENCE STATEMENT (U.S.A. ONLY)

This equipment generates and uses ISM frequency energy and if not installed and used properly, that is in strict accordance with the manufacturer's instructions, may cause interference to radio and television reception. It has been type tested and found to comply with limits for ISM Equipment pursuant to part 18 of FCC Rules, which are designed to part 18 of FCC Rules, which are designed to provide residential installation.

However, there is no guarantee that interference will not occur in a particular installation. If this equipment does cause interference to radio or television reception, which can be determined by turning the equipment off and on, the user is encouraged to try to correct the interference by one or more of the following:

- Reorient the receiving antenna of the radio or

television.

- Relocate the Microwave Oven with respect to the receiver.
- Move the microwave oven away from the receiver.
- Plug the microwave oven into a different outlet so that the microwave oven and the receiver are on different branch codes.

The manufacturer is not responsible for any radio or TV interference caused by unauthorized modification to this microwave oven. It is the responsibility of the user to correct such interference.

## Optional Accessories

Available at extra cost from your Café Appliances supplier.

### Filler Panel Kit

#### JX36BSS - Stainless

When replacing a 36" range hood, filler panel kits fill in the additional width to provide a custom built-in appearance.

For installation between cabinets only; not for end-of-cabinet installation. Each kit contains two 3" wide filler panels.

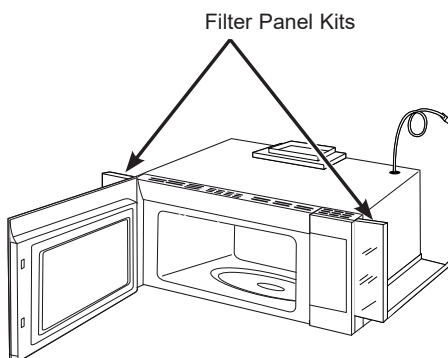

### Recirculating Charcoal Filter Kit

Filter kits are used when the microwave oven cannot be vented to the outside.

### 15" Cabinet Installation Kit

For use when installing with 15" depth cabinets.

Available at extra cost from your Café Appliances supplier, or see the Café Appliances Service numbers.

## Troubleshooting Tips... Before you schedule service

Save time and money! Review the charts on the following pages first and you may not need to schedule service.

Problem	Possible Causes	What To Do
Oven will not start	A fuse in your home may be blown or the circuit breaker tripped.	Replace fuse or reset circuit breaker.
	Power surge.	Unplug the microwave oven, then plug it back in.
	Plug not fully inserted into wall outlet.	Make sure the 3-prong plug on the oven is fully inserted into wall outlet.
	Door not securely closed.	Open the door and close securely.
Control panel lighted, yet oven will not start	Door not securely closed.	Open the door and close securely.
	START button not pressed after entering cooking selection.	Press <b>START</b> .
	Another selection entered already in oven and OFF/CLEAR button not pressed to cancel it.	Press <b>OFF/CLEAR</b> .
	Cooking time not entered after pressing TIME COOK.	Make sure you have entered cooking time after pressing <b>TIME COOK</b> .
	OFF/CLEAR was pressed accidentally.	Reset cooking program and press <b>START</b> .
	Food weight not entered after selecting AUTO DEFROST.	Make sure you have entered food weight after selecting <b>AUTO DEFROST</b> .
	Food type not entered after pressing COOK.	Make sure you have entered a food type.
CONTROL LOCKED appears on display	The control has been locked.	Press and hold <b>OFF/CLEAR</b> for about 3 seconds to unlock the control.
HOT appears on display	The temperature inside the oven is greater than 200°F.	This is normal.
	One of the sensor cooking pads was pressed when the temperature inside the oven was greater than 200°F.	These features will not operate when the oven is hot.



# Café Microwave Oven Limited Warranty

**LIMITED WARRANTY**

## cafeappliances.com

All warranty service is provided by our Factory Service Centers, or an authorized service technician. To schedule service online, visit us at [cafeappliances.com/service](http://cafeappliances.com/service). Please have your serial number and your model number available when scheduling service.

For the period of	Café will replace
<b>One year</b> From the date of the original purchase	Café <b>will choose to replace or service</b> the defective unit. <i>In the event of service, Café will provide</i> any part of the microwave oven which fails due to a defect in materials or workmanship. During this <b>limited one-year warranty</b> , GE Appliances will also provide, free of charge, all labor and related service costs to replace the defective part when the unit is serviced.
<b>Five year</b> From the date of the original Purchase	<b>For the period of Five Years from the date of the original purchase, Café will choose to either replace the unit or replace the magnetron tube, if the magnetron tube</b> fails due to a defect in materials or workmanship. During this <b>five –year limited warranty</b> , you will be responsible for any labor or in-home service cost.

### What Café will not cover:

- Service trips to your home to teach you how to use the product.
- Improper installation, delivery or maintenance. If you have an installation problem, contact your dealer or installer. You are responsible for providing adequate electrical, exhausting, and other connecting facilities.
- Failure of the product or damage to the product if it is abused, misused (for example, cavity arcing from wire rack or metal/foil), or used for other than the intended purpose or used commercially.
- Replacement of house fuses or resetting of circuit breakers.
- Damage to the product caused by accident, fire, floods, or acts of God.
- Damage to finish, such as surface rust, tarnish, or small blemishes not reported within 48 hours of delivery.
- Incidental or consequential damage caused by possible defects with this appliance.
- Damage caused after delivery.
- Product not accessible to provide required service.
- Service to repair or replace light bulbs, except for LED lamps.

### EXCLUSION OF IMPLIED WARRANTIES

Your sole and exclusive remedy is product repair as provided in this Limited Warranty. Any implied warranties, including the implied warranties of merchantability or fitness for a particular purpose, are limited to one year or the shortest period allowed by law.

This limited warranty is extended to the original purchaser and any succeeding owner for products purchased for home use within the USA. If the product is located in an area where service by a Café Authorized Servicer is not available, you may be responsible for a trip charge or you may be required to bring the product to an Authorized Café Service location for service. In Alaska, the limited warranty excludes the cost of shipping or service calls to your home. Some states do not allow the exclusion or limitation of incidental or consequential damages. This limited warranty gives you specific legal rights, and you may also have other rights which vary from state to state. To know what your legal rights are, consult your local or state consumer affairs office or your state's Attorney General.

**Warrantor: GE Appliances, a Haier company**  
 Louisville, KY 40225

**Extended Warranties:** Purchase a Café extended warranty and learn about special discounts that are available while your warranty is still in effect. You can purchase it online anytime at

[cafeappliances.com/extended-warranty](http://cafeappliances.com/extended-warranty)

Café Service will still be there after your warranty expires.

Staple your receipt here. Proof of the original purchase date is needed to obtain service under the warranty.

# Consumer Support

---

## Café Website

Have a question or need assistance with your appliance? Try the Café website 24 hours a day, any day of the year! You can also shop for more great Café products and take advantage of all our on-line support services designed for your convenience. In the US: [cafeappliances.com](http://cafeappliances.com)

---

## Register Your Appliance

Register your new appliance on-line at your convenience! Timely product registration will allow for enhanced communication and prompt service under the terms of your warranty, should the need arise. You may also mail in the pre-printed registration card included in the packing material. In the US: [cafeappliances.com/register](http://cafeappliances.com/register)  
In Canada: [cafeappliances.ca/registration](http://cafeappliances.ca/registration)

---

## Schedule Service

Expert Café repair service is only one step away from your door. Get on-line and schedule your service at your convenience any day of the year. In the US: [cafeappliances.com/service](http://cafeappliances.com/service)

---

## Extended Warranties

Purchase a Café extended warranty and learn about special discounts that are available while your warranty is still in effect. You can purchase it on-line anytime. Café Service will still be there after your warranty expires.  
In the US: [cafeappliances.com/extended-warranty](http://cafeappliances.com/extended-warranty)

---

## Remote Connectivity

For assistance with wireless network connectivity (for models with remote enable), visit our website at [cafeappliances.com/connect](http://cafeappliances.com/connect)

---

## Parts and Accessories

Individuals qualified to service their own appliances can have parts or accessories sent directly to their homes (VISA, MasterCard and Discover cards are accepted). Order on-line today 24 hours every day.  
In the US: [cafeappliances.com/parts](http://cafeappliances.com/parts)

**Instructions contained in this manual cover procedures to be performed by any user. Other servicing generally should be referred to qualified service personnel. Caution must be exercised, since improper servicing may cause unsafe operation.**

---

## Contact Us

If you are not satisfied with the service you receive from Café, contact us on our website with all the details including your phone number, or write to:

In the US: General Manager, Customer Relations | Café Appliances, Appliance Park | Louisville, KY 40225  
[cafeappliances.com/contact](http://cafeappliances.com/contact)

# Microwave Oven

**Thank You! ...** for your purchase of a GE Brand appliance.

**Register Your Appliance:** Register your new appliance on-line at your convenience!

[www.geappliances.com/service\\_and\\_support/register/](http://www.geappliances.com/service_and_support/register/)

Timely product registration will allow for enhanced communication and prompt service under the terms of your warranty, should the need arise. You may also mail in the pre-printed registration card included in the packing material.

For a full manual in English and Spanish visit

Para un manual completo en inglés y español,

[www.GEAppliances.com](http://www.GEAppliances.com)

Or call to order a paper copy

O llame para pedir una copia de papel

800.626.2000

You will need to have your model number ready before you call.

When using electrical appliances basic safety precautions should be followed, including the following:

## IMPORTANT SAFETY INSTRUCTIONS



**WARNING**

**READ ALL INSTRUCTIONS BEFORE USING.**

Death or serious injury can result from failure to follow these instructions. To reduce the risk of burns, electric shocks, fire, injury to persons or exposure to excessive microwave energy:

- Read and follow the specific precautions in the PRECAUTIONS TO AVOID POSSIBLE EXPOSURE TO EXCESSIVE MICROWAVE ENERGY section.
- Use this appliance only for its intended use as described in this manual. Do not use corrosive chemicals or vapors in this appliance. This microwave oven is specifically designed to heat, dry or cook food, and is not intended for laboratory or industrial use.
- This microwave should be serviced only by qualified service personnel. Contact nearest authorized service facility for examination, repair, or adjustment.

### INSTALLATION

- Install or locate this appliance only in accordance with the provided installation instructions.
- This appliance must be grounded. Connect only to a properly grounded outlet. See the GROUNDING INSTRUCTIONS section in this guide.
- This microwave oven is UL listed for installation over both gas (less than 60,000 BTU) and electric ranges.
- This unit is suitable for use above gas or electric cooking equipment, 36" or less wide.
- Do not operate this appliance if it has a damaged power cord or plug, if it is not working properly, or if it has been damaged or dropped.
- Keep power cord away from heated surfaces.
- Do not let power cord hang over edge of table or counter.
- Do not immerse power cord or plug in water.
- Do not block or cover any openings on the appliance.
- Do not store this appliance outdoors. Do not use this product near water—for example, in a wet basement, near a swimming pool, near a sink or in similar location.
- Do not mount this appliance over a sink.

### TO REDUCE THE RISK OF FIRE IN THE OVEN CAVITY

- Do not overcook food. Carefully attend appliance when paper, plastic or other combustible materials are placed inside the oven while cooking.
- Remove wire twist-ties and metal handles from paper or plastic containers before placing them in the oven.
- Do not store any materials, other than our recommended accessories, in this oven when not in use. Do not leave paper products, cooking utensils or food in the cavity when not in use. Microwave rack should be removed from oven when not in use.
- If materials inside the oven ignite, keep the oven door closed, turn the oven off and disconnect the power cord, or shut off power at the fuse or circuit breaker panel.
- Do not operate the microwave without food in the oven.

### TO REDUCE THE RISK OF BURNS

- Be careful when opening containers of hot food. Use pot holders and direct steam away from face and hands.
- Vent, pierce, or slit containers, pouches, or plastic bags to prevent build-up of pressure.
- Be careful when touching the turntable, door, or walls of the oven which may become hot during use.
- Liquids and certain foods heated in the microwave oven can present a risk of burn when removing them from the microwave. The potential for a burn is greater in young children, who should not be allowed to remove hot items from the microwave.

### OPERATING AND CLEANING

- As with any appliance, close supervision is necessary when used by children.
- Do not store anything directly on top of the microwave surface when the microwave oven is in operation.
- Oversized food or oversized metal cookware should not be used in a microwave/convection oven because they increase the risk of electric shock and could cause a fire.
- Do not clean with metal scouring pads. Pieces can burn off the pad and touch electrical parts involving risk of electric shock.
- Do not use paper products in oven when appliance is operated in any cooking mode except microwave only.

**SAVE THESE INSTRUCTIONS**

# IMPORTANT SAFETY INSTRUCTIONS. READ ALL INSTRUCTIONS BEFORE USING.

---

## **OPERATING AND CLEANING (Continued)**

- Some products such as whole eggs and sealed containers—for example, closed jars—are able to explode and should not be heated in this microwave oven.
- Do not cover the microwave rack or any part of the oven with metal foil. This will cause overheating of the microwave/convection oven.
- Cook meat and poultry thoroughly—meat to at least an INTERNAL temperature of 160°F and poultry to at least an INTERNAL temperature of 180°F. Cooking to these temperatures usually protects against foodborne illness.
- Make sure all cookware used in your microwave oven is suitable for microwaving. Most glass casseroles, cooking dishes, measuring cups, custard cups, pottery or china dinnerware which does not have metallic trim or glaze with a metallic sheen can be used in compliance with cookware manufacturers' recommendations.
- It is important to keep the area clean where the door seals against the microwave. Use only mild, nonabrasive detergents applied with a clean sponge or soft cloth. Rinse well.

## **SUPERHEATED WATER**

- Liquids, such as water, coffee, or tea, are able to be overheated beyond the boiling point without appearing to be boiling. Visible bubbling or boiling when the container is removed from the microwave oven is not always present. *THIS COULD RESULT IN VERY HOT LIQUIDS SUDDENLY BOILING OVER WHEN THE CONTAINER IS DISTURBED OR A SPOON OR OTHER UTENSIL IS INSERTED INTO THE LIQUID.*

To reduce the risk of injury to persons:

- Do not overheat the liquid.
- Stir the liquid both before and halfway through heating it.
- Do not use straight-sided containers with narrow necks.
- After heating, allow the container to stand in the microwave oven for a short time before removing the container.
- Use extreme care when inserting a spoon or other utensil into the container.

## **USE OF THE MICROWAVE RACK ACCESSORY**

- Remove the microwave rack from the oven when not in use.
- Use pot holders when handling the microwave rack and cookware. They may be hot.
- Be sure that the microwave rack is positioned properly inside the oven to prevent product damage.

## GROUNDING INSTRUCTIONS



### **WARNING**

To prevent risk of electric shock, follow these instructions:

- Plug microwave into a grounded 3-prong outlet.
- Do not remove the ground prong or use an adapter.
- Do not use an extension cord.

### **Improper use of the grounding plug can result in a risk of electric shock.**

This appliance must be grounded. In the event of an electrical short circuit, grounding reduces the risk of electric shock by providing an escape wire for the electric current.

This appliance is equipped with a power cord having a grounding wire with a grounding plug. The plug must be plugged into an outlet that is properly installed and grounded.

## VENT FAN

The fan will operate automatically under certain conditions. Take care to prevent the starting and spreading of accidental cooking fires while the vent fan is in use.

- Clean the underside of the microwave often. Do not allow grease to build up on the microwave or the fan filters.
- In the event of a grease fire on the surface units below the microwave oven, smother a flaming pan on the surface unit by covering the pan completely with a lid, a cookie sheet or a flat tray.

Consult a qualified electrician or service technician if the grounding instructions are not completely understood, or if doubt exists as to whether the appliance is properly grounded.

A short power-supply is provided to reduce the risks resulting from becoming entangled or tripping over a longer cord. Do not use an extension cord with this appliance. If the power cord is too short, have a qualified electrician or service technician install an outlet near the appliance.

- Use care when cleaning the vent fan filters. Corrosive cleaning agents, such as lye-based oven cleaners, may damage the filters.
- When preparing flaming foods under the microwave, turn the fan on.
- Never leave surface units beneath your microwave oven unattended at high heat settings. Boilovers cause smoking and greasy spillovers that may ignite and spread if the microwave vent fan is operating. To minimize automatic fan operation, use adequate sized cookware and use high heat on surface units only when necessary.

## PACEMAKERS

Most pacemakers are shielded from interference from electronic products, including microwaves. However, patients with pacemakers may wish to consult their physicians if they have concerns.

## SAVE THESE INSTRUCTIONS

# IMPORTANT SAFETY INSTRUCTIONS. READ ALL INSTRUCTIONS BEFORE USING.

## PRECAUTIONS TO AVOID POSSIBLE EXPOSURE TO EXCESSIVE MICROWAVE ENERGY

- **Do Not Attempt** to operate this oven with the door open since open-door operation can result in harmful exposure to microwave energy. It is important not to defeat or tamper with the safety interlocks.
- **Do Not Place** any object between the oven front face and the door or allow soil or cleaner residue to accumulate on sealing surfaces.
- **Do Not Operate** the oven if it is damaged. It is particularly important that the oven door close properly and that there is no damage to the:
  - (1) door (bent)
  - (2) hinges and latches (broken or loosened)
  - (3) door seals and sealing surfaces
- **The Oven Should Not** be adjusted or repaired by anyone except properly qualified service personnel. Contact nearest authorized service facility for examination, repair or adjustment.

READ AND FOLLOW THIS SAFETY INFORMATION CAREFULLY.

## SAVE THESE INSTRUCTIONS

## FEDERAL COMMUNICATIONS COMMISSION (U.S.A.) RADIO FREQUENCY INTERFERENCE STATEMENT

This equipment generates and uses ISM frequency energy and if not installed and used properly, that is in strict accordance with the manufacturer's instructions, may cause interference to radio and television reception. It has been type tested and found to comply with limits for an ISM Equipment pursuant to part 18 of FCC Rules, which are designed to provide reasonable protection against such interference in a residential installation. However, there is no guarantee that interference will not occur in a particular installation. If this equipment does cause interference to radio or television reception, which can be determined by tuning the equipment off and on, the user is encouraged to try to correct the interference by one or more of the following:

- Reorient the receiving antenna of radio or television.
- Relocate the Microwave oven with respect to the receiver.
- Move the microwave oven away from the receiver.
- Plug the microwave oven into a different outlet so that microwave oven and receiver are on different branch circuits.

The manufacturer is not responsible for any radio or TV interference cause by unauthorized modification to this microwave oven. It is the responsibility of the user to correct such interference.

## Have a question or need assistance with your appliance?

Try the GE Appliances Website ([www.geappliances.com/service\\_and\\_support/](http://www.geappliances.com/service_and_support/)) 24 hours a day, any day of the year! For greater convenience and faster service, you can now download Owner's Manuals, order parts or even schedule service on-line.

**Schedule Service:** Expert GE repair service is only one step away from your door. Get on-line and schedule your service at [www.geappliances.com/service\\_and\\_support/](http://www.geappliances.com/service_and_support/) Or call 800.GE.CARES (800.432.2737) during normal business hours.

**Parts and Accessories:** Individuals qualified to service their own appliances can have parts or accessories sent directly to their homes (VISA, MasterCard and Discover cards are accepted). Order on-line today, 24 hours every day or by phone at 800.626.2002 during normal business hours.

Instructions contained in this manual cover procedures to be performed by any user. Other servicing generally should be referred to qualified service personnel. Caution must be exercised, since improper servicing may cause unsafe operation.

**Real Life Design Studio:** GE supports the Universal Design concept of products, services and environments that can be used by people of all ages, sizes and capabilities. We recognize the need to design for a wide range of physical and mental abilities and impairments. For details of GE's Universal Design applications, including kitchen design ideas for people with disabilities, check out our Website today. For the hearing impaired, please call 800.TDD.GEAC (800.833.4322).

**Contact Us:** If you are not satisfied with the service you receive from GE, contact us on our Website [www.geappliances.com/service/chat](http://www.geappliances.com/service/chat) with all the details including your phone number, or write to:  
**General Manager, Customer Relations**  
GE Appliances, Appliance Park Louisville, KY 40225

# GE Microwave Oven Warranty.

---

## GEAppliances.com

All warranty service is provided by our Factory Service Centers, or an authorized Customer Care® technician. To schedule service, on-line, visit us at [www.geappliances.com/service\\_and\\_support/](http://www.geappliances.com/service_and_support/), or call 800.GE.CARES (800.432.2737). Please have serial number and model number available when calling for service.

**For the period of One Year from the date of the original purchase, GE will choose to replace or service the defective unit.** In the event of service, **GE will provide** any part of the microwave oven which fails due to a defect in materials or workmanship. During this **limited one-year warranty**, GE will also provide, free of charge, all labor and related service costs to replace the defective part when the unit is serviced.

**On Cafe and Monogram branded models only: For the period of Five Years from the date of the original purchase, GE will replace the magnetron tube**, if the magnetron tube fails due to a defect in materials or workmanship. During this **five -year limited warranty**, you will be responsible for any labor or in-home service cost.

## What GE will not cover:

- Service trips to your home to teach you how to use the product.
- Improper installation, delivery or maintenance. If you have an installation problem, contact your dealer or installer. You are responsible for providing adequate electrical, exhausting, and other connecting facilities.
- Failure of the product or damage to the product if it is abused, misused (for example, cavity arcing from wire rack or metal/foil), or used for other than the intended purpose or used commercially.
- Replacement of house fuses or resetting of circuit breakers.
- Damage to the product caused by accident, fire, floods or acts of God.
- Incidental or consequential damage caused by possible defects with this appliance.
- Damage caused after delivery.
- Product not accessible to provide required service.
- Service to repair or replace light bulbs, except for LED lamps.
- Damage to the finish, such as surface rust, tarnish, or small blemishes not reported within 48 hrs of delivery.

## EXCLUSION OF IMPLIED WARRANTIES

Your sole and exclusive remedy is product repair as provided in this Limited Warranty. Any implied warranties, including the implied warranties of merchantability or fitness for a particular purpose, are limited to one year or the shortest period allowed by law.

This warranty is extended to the original purchaser and any succeeding owner for products purchased for home use within the USA. If the product is located in an area where service by a GE Authorized Servicer is not available, you may be responsible for a trip charge or you may be required to bring the product to an Authorized GE Service location for service. In Alaska, the warranty excludes the cost of shipping or service calls to your home.

Some states do not allow the exclusion or limitation of incidental or consequential damages. This warranty gives you specific legal rights, and you may also have other rights which vary from state to state. To know what your legal rights are, consult your local or state consumer affairs office or your state's Attorney General.

**Warrantor: General Electric Company. Louisville, KY 40225**

---

**Extended Warranties:** Purchase a GE extended warranty and learn about special discounts that are available while your warranty is still in effect. You can purchase it on-line anytime

[www.geappliances.com/service\\_and\\_support/shop-for-extended-service-plans.htm](http://www.geappliances.com/service_and_support/shop-for-extended-service-plans.htm)

or call 800.626.2224 during normal business hours. GE Consumer Home Services will still be there after your warranty expires.

## Accessories

---

### Looking For Something More?

**GE offers a variety of accessories to improve your cooking and maintenance experiences!** To place an order visit us online at:

[www.GEApplianceParts.com](http://www.GEApplianceParts.com) (U.S.) or [www.GEAppliances.ca](http://www.GEAppliances.ca) (Canada)  
or call **800.626.2002** (U.S.) **800.661.1616** (Canada)

*The following products and more are available at extra cost from your GE supplier.*

#### **36" Width Filler Kits**

When replacing a 36" range hood, filler panel kits fill in the additional width to provide a custom built-in appearance. For installation between cabinets only; not for end-of cabinet installation. Each kit contains two 3" wide filler panels.

#### **15" Cabinet Installation Kit**

For use with cabinets deeper than 12 inches. Brings microwave further out from the wall for improved ventilation, access, and appearance.

#### **Charcoal Filter Kits**

Filter kits are used when the oven cannot be vented to the outside. Please check online in your full Owner's Manual for filter installation Instructions. Replace your filters every 6 months.

#### **Cooktop Lights/Nite Lights**

#### **Oven Cavity Lamp**

# Features May Differ by Model.

---

For more details about how to use your new appliance, please consult the full Owner's Manual - information on front cover.

## Cooking Operations.

---

### Weight (Auto)Defrost

Press Defrost (use dial, if present, to select by weight), enter weight (in pounds) and then press start.

#### *Weight Defrosting Tips:*

- Remove meat from package, place on microwave-safe dish.
- When the oven signals, turn the food over. Remove defrosted meat or shield warm areas with small pieces of foil.
- After defrosting, let stand 5 minutes to complete defrosting. Large roasts should stand for about 30 minutes.
- For more even defrosting of larger foods, such as roasts, use Time Defrost. Be sure large meats are completely defrosted before cooking.

### Time Defrost

Press Defrost until prompted for a time (use dial to select by time), enter time, then press start.

#### *Timed Defrosting Tips:*

- At one half of selected defrosting time, turn food over and break apart or rearrange pieces for more even defrosting. Shield any warm areas with small pieces of foil.
- Foods frozen in paper or plastic can be defrosted in the package. Closed packages should be slit, pierced or vented AFTER food has partially defrosted. Plastic storage containers should be partially uncovered.
- If the food is in a foil container, transfer it to a microwave-safe dish.

### Popcorn

For use with prepackaged microwave popcorn. If additional cooking time is needed, use Add 30 seconds and watch carefully. **NOTE:** Do not use this feature twice in succession on the same food portion - it may result in severely overcooked or burnt food.

### Reheat

Brings previously cooked food back to serving temperature. Press Reheat and follow the prompts on the display (use the reheat and number pads to change selections) to select the desired food/quantity, then press Start (will start automatically on some models).

**Express Cook** (1-5, Add 30 sec, Micro Express + dial depending on model) Immediately starts microwave at power level 10 for the number of minutes selected. Add 30 sec or the dial can be used to increase time while microwave is running without stopping cooking.

### Turntable

Sets turntable rotation off for large dishes, or returns turntable to on. For best cooking results, leave the turntable on. It can be turned off for large dishes. The turntable automatically returns to ON at the end of a cooking time on some models. Accessed using the Setting pad on some models.

### Multi-Level Microwaving

The microwave rack (on some models) allows you to microwave several foods at once. Food microwaves best when placed directly on the floor or the turntable.

Only use microwave rack when reheating on more than one level.

DO NOT store the rack in the microwave.

Do not use the rack with REHEAT or when cooking popcorn.

To avoid damage to the appliance, the rack must be positioned properly on the supports and never used on the microwave floor.

## Non-Cooking Operations...Control features that do not cook food.

---

**Set Clock:** This is a standard 12-hour clock (12:00 - 11:59). To set -press Settings (2 times on number models) or Set Clock, enter time, (select AM or PM on some models), use Settings or Set Clock to accept time.

**Surface Light:** Controls the light below the microwave. Press once for bright light, twice for a dimmer night light, or a third time to turn the light off.

**Vent Fan:** Activates and adjusts speed of ventilation fan located on the bottom of the microwave to remove steam and vapors from surface cooking. Models have up to 4 speeds. First press activates highest fan speed. Subsequent presses decrease through speeds to OFF.

**Filter Cleaning:** Clean the vent filters by soaking them and swishing around in hot water and detergent (not ammonia - it causes discoloration). Brush lightly to remove embedded dirt. Rinse, shake, and let dry before replacing.

## Troubleshooting tips ... Before you call for service

Problem	Possible Cause	What to Do
Oven will not start	A fuse in your home may be blown or the circuit breaker tripped	Replace fuse or reset circuit breaker.
	Power surge	Unplug the microwave oven, then plug it back in.
	Plug not fully inserted into wall outlet	Make sure the 3-prong on the oven is fully inserted into the wall outlet.
	Door not securely closed	Open the door and close it securely.
Control panel lighted, yet oven will not start	Door not securely closed	Open the door and close it securely.
	START/PAUSE button not pressed after entering cooking selection	Press START/PAUSE.
	Another selection entered already in oven and CANCEL/OFF button not pressed to cancel it	Press CANCEL/OFF.
	Cooking time not entered after pressing COOK TIME	Make sure you have entered cooking time after pressing COOK TIME.
	CANCEL/OFF was pressed accidentally	Reset cooking program and press START/PAUSE.
CONTROL LOCKED appears on display	The control has been locked	Press and hold LOCK CONTROL for About 3 seconds to unlock the control.
Floor of the oven is warm even when the oven has not been used	The cooktop light is located below the oven floor. When light is on, the heat it produces may make the oven floor get warm	This is normal.
You hear an unusual low-tone beep	You have tried to change the power level when it is not allowed	Many of the oven's features are preset and cannot be changed.
Vent fan comes on automatically	The vent fan automatically turns on to protect the microwave if it senses too much heat rising from the cooktop below	This is normal.
There are sparks in the oven (arcing)	<ul style="list-style-type: none"> <li>• Metal or foil touching the side of the oven.</li> <li>• Turntable ring support not installed correctly.</li> <li>• Foil not molded to food (upturned edges act like antennas).</li> <li>• Metal, such as twist-ties, poultry pins, or gold-rimmed dishes, in the microwave.</li> <li>• Recycled paper towels containing small metal pieces being used in the microwave.</li> <li>• The metal rack (on some models) not installed correctly so it touches the microwave wall.</li> </ul>	Verify the turntable ring support and (if applicable) metal rack are installed correctly. Remove other arcing sources from the oven.

## Things that are normal with your microwave oven.

- Moisture on the oven door and walls while cooking. Wipe the moisture off with a paper towel or soft cloth.
- Moisture between the oven door panels when cooking certain foods. Moisture should dissipate shortly after cooking is finished.
- On some models, the display is designed to turn off when unit is idle for 30 seconds to minimize the standby power usage. Display will turn on when control is in use or door is opened.
- Steam or vapor escaping from around the door.
- Light reflection around door or outer case.
- Dimming oven light and change in the blower sound at power levels other than high.
- Noises while oven is operating.



MBM64796407