

NR Band 41 (IC)										
BW (MHz)	SCS (kHz)	Modulation	RB Size	RB Offset	Conducted Output Power					
					502002 (2 510.01 MHz)		519000 (2 595.00 MHz)		535998 (2 679.99 MHz)	
					(dB m)	(W)	(dB m)	(W)	(dB m)	(W)
20	30	DFT-S-OFDM BPSK	1	1	25.87	0.386	25.70	0.372	25.97	0.395
			1	26	25.80	0.380	25.73	0.374	25.98	0.396
			1	49	25.99	0.397	25.71	0.372	25.97	0.395
			25	0	25.69	0.371	25.21	0.332	25.45	0.351
			25	13	25.98	0.396	25.63	0.366	25.97	0.395
			25	26	25.79	0.379	25.15	0.327	25.56	0.360
		DFT-S-OFDM QPSK	1	1	25.89	0.388	25.80	0.380	25.97	0.395
			1	26	25.90	0.389	25.71	0.372	25.98	0.396
			1	49	25.85	0.385	25.74	0.375	25.94	0.393
			25	0	25.27	0.337	24.70	0.295	25.05	0.320
			25	13	25.98	0.396	25.73	0.374	25.96	0.394
			25	26	25.13	0.326	24.71	0.296	25.18	0.330
		DFT-S-OFDM 16QAM	1	1	25.12	0.325	24.73	0.297	24.95	0.313
			1	1	23.65	0.232	23.19	0.208	23.58	0.228
			1	1	24.76	0.299	24.10	0.257	24.57	0.286
			1	1	24.22	0.264	23.62	0.230	23.93	0.247
			1	1	22.62	0.183	22.15	0.164	22.62	0.183
			1	1	22.62	0.183	22.15	0.164	22.62	0.183
NR Band 41 (IC)										
BW (MHz)	SCS (kHz)	Modulation	RB Size	RB Offset	Conducted Output Power					
					503004 (2 515.02 MHz)		519000 (2 595.00 MHz)		534996 (2 674.98 MHz)	
					(dB m)	(W)	(dB m)	(W)	(dB m)	(W)
30	30	DFT-S-OFDM BPSK	1	1	25.98	0.396	25.66	0.368	25.50	0.355
			1	39	25.95	0.394	25.76	0.377	25.60	0.363
			1	76	25.85	0.385	25.75	0.376	25.40	0.347
			36	0	25.50	0.355	25.16	0.328	24.91	0.310
			36	21	25.97	0.395	25.73	0.374	25.41	0.348
			36	42	25.45	0.351	25.16	0.328	25.08	0.322
		DFT-S-OFDM QPSK	1	1	25.95	0.394	25.70	0.372	25.59	0.362
			1	39	25.97	0.395	25.59	0.362	25.46	0.352
			1	76	25.90	0.389	25.74	0.375	25.53	0.357
			36	0	25.19	0.330	24.66	0.292	24.54	0.284
			36	21	25.90	0.389	25.60	0.363	25.40	0.347
			36	42	25.01	0.317	24.65	0.292	24.57	0.286
		DFT-S-OFDM 16QAM	1	1	25.09	0.323	24.58	0.287	24.55	0.285
			1	1	24.96	0.313	24.66	0.292	24.52	0.283
			1	1	23.44	0.221	23.13	0.206	22.92	0.196
			1	1	24.44	0.278	24.09	0.256	24.05	0.254
			1	1	24.06	0.255	23.57	0.228	23.52	0.225
			1	1	22.57	0.181	22.26	0.168	21.94	0.156

NR Band 41 (IC)										
BW (MHz)	SCS (kHz)	Modulation	RB Size	RB Offset	Conducted Output Power					
					504000 (2 520.00 MHz)		519000 (2 595.00 MHz)		534000 (2 670.00 MHz)	
					(dB m)	(W)	(dB m)	(W)	(dB m)	(W)
40	30	DFT-S-OFDM BPSK	1	1	25.93	0.392	25.78	0.378	25.62	0.365
			1	53	25.98	0.396	25.80	0.380	25.55	0.359
			1	104	25.92	0.391	25.73	0.374	25.56	0.360
			50	0	25.70	0.372	25.37	0.344	25.18	0.330
			50	28	25.96	0.394	25.71	0.372	25.57	0.361
			50	56	25.56	0.360	25.32	0.340	25.04	0.319
			100	0	25.70	0.372	25.37	0.344	25.14	0.327
		DFT-S-OFDM QPSK	1	1	25.98	0.396	25.69	0.371	25.55	0.359
			1	53	25.93	0.392	25.84	0.384	25.71	0.372
			1	104	25.97	0.395	25.79	0.379	25.64	0.366
			50	0	25.02	0.318	24.84	0.305	24.59	0.288
			50	28	25.91	0.390	25.75	0.376	25.59	0.362
			50	56	25.05	0.320	24.86	0.306	24.58	0.287
			100	0	25.09	0.323	24.80	0.302	24.58	0.287
		DFT-S-OFDM 16QAM	1	1	25.20	0.331	24.87	0.307	24.56	0.286
		DFT-S-OFDM 64QAM	1	1	23.55	0.226	23.22	0.210	23.19	0.208
		CP-OFDM QPSK	1	1	24.71	0.296	24.20	0.263	24.10	0.257
		CP-OFDM 16QAM	1	1	24.10	0.257	23.76	0.238	23.71	0.235
CP-OFDM 64QAM	1	1	22.73	0.187	22.37	0.173	22.21	0.166		
NR Band 41 (IC)										
BW (MHz)	SCS (kHz)	Modulation	RB Size	RB Offset	Conducted Output Power					
					505002 (2 525.01 MHz)		519000 (2 595.00 MHz)		532998 (2 664.99 MHz)	
					(dB m)	(W)	(dB m)	(W)	(dB m)	(W)
50	30	DFT-S-OFDM BPSK	1	1	25.90	0.389	25.53	0.357	25.75	0.376
			1	67	25.95	0.394	25.57	0.361	25.85	0.385
			1	131	25.91	0.390	25.48	0.353	25.68	0.370
			64	0	25.55	0.359	24.95	0.313	25.20	0.331
			64	35	25.95	0.394	25.43	0.349	25.79	0.379
			64	69	25.50	0.355	25.05	0.320	25.29	0.338
			128	0	25.50	0.355	25.05	0.320	25.19	0.330
		DFT-S-OFDM QPSK	1	1	25.98	0.396	25.60	0.363	25.71	0.372
			1	67	25.96	0.394	25.56	0.360	25.65	0.367
			1	131	25.94	0.393	25.43	0.349	25.74	0.375
			64	0	24.90	0.309	24.42	0.277	24.68	0.294
			64	35	25.93	0.392	25.46	0.352	25.70	0.372
			64	69	25.14	0.327	24.41	0.276	24.77	0.300
			128	0	25.08	0.322	24.57	0.286	24.82	0.303
		DFT-S-OFDM 16QAM	1	1	24.98	0.315	24.54	0.284	24.83	0.304
		DFT-S-OFDM 64QAM	1	1	23.47	0.222	23.12	0.205	23.25	0.211
		CP-OFDM QPSK	1	1	24.55	0.285	23.93	0.247	24.34	0.272
		CP-OFDM 16QAM	1	1	24.00	0.251	23.47	0.222	23.70	0.234
CP-OFDM 64QAM	1	1	22.56	0.180	22.03	0.160	22.34	0.171		

NR Band 41 (IC)										
BW (MHz)	SCS (kHz)	Modulation	RB Size	RB Offset	Conducted Output Power					
					506004 (2 530.02 MHz)		519000 (2 595.00 MHz)		531996 (2 659.98 MHz)	
					(dB m)	(W)	(dB m)	(W)	(dB m)	(W)
60	30	DFT-S-OFDM BPSK	1	1	25.93	0.392	25.53	0.357	25.46	0.352
			1	81	25.96	0.394	25.63	0.366	25.50	0.355
			1	160	25.90	0.389	25.60	0.363	25.46	0.352
			81	0	25.47	0.352	25.02	0.318	24.87	0.307
			81	41	25.93	0.392	25.45	0.351	25.56	0.360
			81	81	25.57	0.361	25.03	0.318	25.05	0.320
		DFT-S-OFDM QPSK	162	0	25.48	0.353	25.09	0.323	24.88	0.308
			1	1	25.91	0.390	25.48	0.353	25.39	0.346
			1	81	25.98	0.396	25.52	0.356	25.39	0.346
			1	160	25.85	0.385	25.60	0.363	25.40	0.347
			81	0	25.15	0.327	24.63	0.290	24.31	0.270
			81	41	25.93	0.392	25.51	0.356	25.51	0.356
		DFT-S-OFDM 16QAM	81	81	25.04	0.319	24.60	0.288	24.47	0.280
			162	0	24.90	0.309	24.50	0.282	24.52	0.283
		DFT-S-OFDM 64QAM	1	1	25.01	0.317	24.54	0.284	24.39	0.275
		DFT-S-OFDM 64QAM	1	1	23.46	0.222	23.07	0.203	23.04	0.201
		CP-OFDM QPSK	1	1	24.56	0.286	24.12	0.258	23.94	0.248
		CP-OFDM 16QAM	1	1	23.94	0.248	23.62	0.230	23.41	0.219
CP-OFDM 64QAM	1	1	22.43	0.175	22.08	0.161	22.03	0.160		
NR Band 41 (IC)										
BW (MHz)	SCS (kHz)	Modulation	RB Size	RB Offset	Conducted Output Power					
					508002 (2 540.01 MHz)		519000 (2 595.00 MHz)		529998 (2 649.99 MHz)	
					(dB m)	(W)	(dB m)	(W)	(dB m)	(W)
80	30	DFT-S-OFDM BPSK	1	1	25.93	0.392	25.61	0.364	25.39	0.346
			1	109	25.97	0.395	25.55	0.359	25.44	0.350
			1	215	25.92	0.391	25.70	0.372	25.30	0.339
			108	0	25.55	0.359	25.21	0.332	24.87	0.307
			108	55	25.93	0.392	25.54	0.358	25.35	0.343
			108	109	25.50	0.355	25.12	0.325	24.79	0.301
		DFT-S-OFDM QPSK	216	0	25.51	0.356	25.21	0.332	24.86	0.306
			1	1	25.96	0.394	25.54	0.358	25.47	0.352
			1	109	25.91	0.390	25.59	0.362	25.43	0.349
			1	215	25.98	0.396	25.67	0.369	25.41	0.348
			108	0	25.08	0.322	24.55	0.285	24.35	0.272
			108	55	25.94	0.393	25.69	0.371	25.42	0.348
		DFT-S-OFDM 16QAM	108	109	24.97	0.314	24.63	0.290	24.39	0.275
			216	0	25.01	0.317	24.67	0.293	24.31	0.270
		DFT-S-OFDM 64QAM	1	1	25.09	0.323	24.69	0.294	24.39	0.275
		DFT-S-OFDM 64QAM	1	1	23.59	0.229	23.19	0.208	22.87	0.194
		CP-OFDM QPSK	1	1	24.45	0.279	24.10	0.257	23.94	0.248
		CP-OFDM 16QAM	1	1	24.02	0.252	23.58	0.228	23.33	0.215
CP-OFDM 64QAM	1	1	22.60	0.182	22.14	0.164	21.90	0.155		

NR Band 41 (IC)										
BW (MHz)	SCS (kHz)	Modulation	RB Size	RB Offset	Conducted Output Power					
					509004 (2 545.02 MHz)		519000 (2 595.00 MHz)		528996 (2 644.98 MHz)	
					(dB m)	(W)	(dB m)	(W)	(dB m)	(W)
90	30	DFT-S-OFDM BPSK	1	1	25.98	0.396	25.58	0.361	25.53	0.357
			1	123	25.93	0.392	25.48	0.353	25.44	0.350
			1	243	25.96	0.394	25.58	0.361	25.60	0.363
			120	0	25.43	0.349	24.98	0.315	25.08	0.322
			120	63	25.94	0.393	25.59	0.362	25.48	0.353
			120	125	25.55	0.359	25.11	0.324	25.06	0.321
		DFT-S-OFDM QPSK	1	1	25.98	0.396	25.56	0.360	25.62	0.365
			1	123	25.91	0.390	25.53	0.357	25.60	0.363
			1	243	25.97	0.395	25.65	0.367	25.58	0.361
			120	0	25.08	0.322	24.47	0.280	24.50	0.282
			120	63	25.97	0.395	25.50	0.355	25.60	0.363
			120	125	25.04	0.319	24.53	0.284	24.54	0.284
		DFT-S-OFDM 16QAM	1	1	25.03	0.318	24.51	0.282	24.62	0.290
			1	1	23.47	0.222	23.01	0.200	22.93	0.196
			1	1	24.57	0.286	24.00	0.251	23.93	0.247
			1	1	23.94	0.248	23.49	0.223	23.62	0.230
			1	1	22.55	0.180	22.02	0.159	22.13	0.163
			1	1	22.55	0.180	22.02	0.159	22.13	0.163
NR Band 41 (IC)										
BW (MHz)	SCS (kHz)	Modulation	RB Size	RB Offset	Conducted Output Power					
					510000 (2 550.00 MHz)		519000 (2 595.00 MHz)		528000 (2 640.00 MHz)	
					(dB m)	(W)	(dB m)	(W)	(dB m)	(W)
100	30	DFT-S-OFDM BPSK	1	1	25.88	0.387	25.49	0.354	25.51	0.356
			1	137	25.96	0.394	25.46	0.352	25.47	0.352
			1	271	25.83	0.383	25.52	0.356	25.51	0.356
			135	0	25.42	0.348	25.05	0.320	25.04	0.319
			135	69	25.84	0.384	25.44	0.350	25.47	0.352
			135	138	25.28	0.337	25.09	0.323	25.04	0.319
		DFT-S-OFDM QPSK	1	1	25.78	0.378	25.46	0.352	25.47	0.352
			1	137	25.78	0.378	25.44	0.350	25.59	0.362
			1	271	25.97	0.395	25.53	0.357	25.48	0.353
			135	0	24.74	0.298	24.52	0.283	24.38	0.274
			135	69	25.97	0.395	25.56	0.360	25.51	0.356
			135	138	24.79	0.301	24.63	0.290	24.52	0.283
		DFT-S-OFDM 16QAM	1	1	24.84	0.305	24.52	0.283	24.42	0.277
			1	1	23.38	0.218	22.95	0.197	23.02	0.200
			1	1	24.30	0.269	23.91	0.246	23.99	0.251
			1	1	23.95	0.248	23.45	0.221	23.52	0.225
			1	1	22.31	0.170	22.00	0.158	22.08	0.161
			1	1	22.31	0.170	22.00	0.158	22.08	0.161

MIMO

NR Band 41 (FCC)										
BW (MHz)	SCS (kHz)	Modulation	RB Size	RB Offset	Conducted Output Power					
					501204 (2 506.02 MHz)		518598 (2 592.99 MHz)		535998 (2 679.99 MHz)	
					Port 1 + Port 2					
					(dB m)	(W)	(dB m)	(W)	(dB m)	(W)
20	30	CP-OFDM QPSK	1	1	25.73	0.374	25.88	0.387	25.69	0.371
			1	26	25.67	0.369	25.95	0.394	25.74	0.375
			1	49	25.63	0.366	25.90	0.389	25.74	0.375
			50	0	24.11	0.258	24.38	0.274	24.26	0.267
		CP-OFDM 16QAM	1	1	24.92	0.310	25.38	0.345	25.15	0.327
CP-OFDM 64QAM	1	1	23.70	0.234	23.72	0.236	23.63	0.231		
NR Band 41 (FCC)										
BW (MHz)	SCS (kHz)	Modulation	RB Size	RB Offset	Conducted Output Power					
					502200 (2 511.00 MHz)		518598 (2 592.99 MHz)		534996 (2 674.98 MHz)	
					Port 1 + Port 2					
					(dB m)	(W)	(dB m)	(W)	(dB m)	(W)
30	30	CP-OFDM QPSK	1	1	25.68	0.370	25.84	0.384	25.98	0.396
			1	39	25.60	0.363	25.81	0.381	25.94	0.393
			1	76	25.78	0.378	25.94	0.393	25.89	0.388
			75	0	24.25	0.266	24.43	0.277	24.39	0.275
		CP-OFDM 16QAM	1	1	25.19	0.330	25.39	0.346	25.20	0.331
CP-OFDM 64QAM	1	1	23.61	0.230	24.03	0.253	23.96	0.249		
NR Band 41 (FCC)										
BW (MHz)	SCS (kHz)	Modulation	RB Size	RB Offset	Conducted Output Power					
					503202 (2 516.01 MHz)		518598 (2 592.99 MHz)		534000 (2 670.00 MHz)	
					Port 1 + Port 2					
					(dB m)	(W)	(dB m)	(W)	(dB m)	(W)
40	30	CP-OFDM QPSK	1	1	25.86	0.385	25.85	0.385	25.90	0.389
			1	53	25.82	0.382	25.97	0.395	25.98	0.396
			1	104	25.80	0.380	25.98	0.396	25.96	0.394
			100	0	24.26	0.267	24.44	0.278	24.49	0.281
		CP-OFDM 16QAM	1	1	25.36	0.344	25.32	0.340	25.49	0.354
CP-OFDM 64QAM	1	1	23.66	0.232	23.79	0.239	23.82	0.241		
NR Band 41 (FCC)										
BW (MHz)	SCS (kHz)	Modulation	RB Size	RB Offset	Conducted Output Power					
					504204 (2 521.02 MHz)		518598 (2 592.99 MHz)		532998 (2 664.99 MHz)	
					Port 1 + Port 2					
					(dB m)	(W)	(dB m)	(W)	(dB m)	(W)
50	30	CP-OFDM QPSK	1	1	25.80	0.380	25.75	0.376	25.67	0.369
			1	67	25.72	0.373	25.80	0.380	25.71	0.372
			1	131	25.63	0.366	25.60	0.363	25.51	0.356
			128	0	24.14	0.259	24.44	0.278	24.25	0.266
		CP-OFDM 16QAM	1	1	25.08	0.322	25.27	0.337	25.08	0.322
CP-OFDM 64QAM	1	1	23.60	0.229	23.61	0.230	23.78	0.239		

NR Band 41 (FCC)										
BW (MHz)	SCS (kHz)	Modulation	RB Size	RB Offset	Conducted Output Power					
					505200 (2 526.00 MHz)		518598 (2 592.99 MHz)		531996 (2 659.98 MHz)	
					Port 1 + Port 2					
					(dB m)	(W)	(dB m)	(W)	(dB m)	(W)
60	30	CP-OFDM QPSK	1	1	25.61	0.364	25.79	0.379	25.68	0.370
			1	81	25.72	0.373	25.91	0.390	25.98	0.396
			1	160	25.63	0.366	25.66	0.368	25.68	0.370
			162	0	24.11	0.258	24.37	0.274	24.32	0.270
		CP-OFDM 16QAM	1	1	24.90	0.309	25.00	0.316	25.00	0.316
CP-OFDM 64QAM	1	1	23.70	0.234	23.76	0.238	23.55	0.226		
NR Band 41 (FCC)										
BW (MHz)	SCS (kHz)	Modulation	RB Size	RB Offset	Conducted Output Power					
					507204 (2 536.02 MHz)		518598 (2 592.99 MHz)		529998 (2 649.99 MHz)	
					Port 1 + Port 2					
					(dB m)	(W)	(dB m)	(W)	(dB m)	(W)
80	30	CP-OFDM QPSK	1	1	25.87	0.386	25.68	0.370	25.92	0.391
			1	109	25.76	0.377	25.47	0.352	25.95	0.394
			1	215	25.56	0.360	25.29	0.338	25.78	0.378
			216	0	24.13	0.259	24.47	0.280	24.48	0.281
		CP-OFDM 16QAM	1	1	25.23	0.333	24.95	0.313	25.09	0.323
CP-OFDM 64QAM	1	1	23.81	0.240	23.78	0.239	23.63	0.231		
NR Band 41 (FCC)										
BW (MHz)	SCS (kHz)	Modulation	RB Size	RB Offset	Conducted Output Power					
					508200 (2 541.00 MHz)		518598 (2 592.99 MHz)		528996 (2 644.98 MHz)	
					Port 1 + Port 2					
					(dB m)	(W)	(dB m)	(W)	(dB m)	(W)
90	30	CP-OFDM QPSK	1	1	25.88	0.387	25.65	0.367	25.75	0.376
			1	123	25.45	0.351	25.55	0.359	25.90	0.389
			1	243	25.59	0.362	25.38	0.345	25.25	0.335
			243	0	24.18	0.262	24.19	0.262	24.41	0.276
		CP-OFDM 16QAM	1	1	25.17	0.329	24.89	0.308	24.88	0.308
CP-OFDM 64QAM	1	1	23.64	0.231	23.58	0.228	23.70	0.234		
NR Band 41 (FCC)										
BW (MHz)	SCS (kHz)	Modulation	RB Size	RB Offset	Conducted Output Power					
					509202 (2 546.01 MHz)		518598 (2 592.99 MHz)		528000 (2 640.00 MHz)	
					Port 1 + Port 2					
					(dB m)	(W)	(dB m)	(W)	(dB m)	(W)
100	30	CP-OFDM QPSK	1	1	25.73	0.374	25.65	0.367	25.65	0.367
			1	137	25.55	0.359	25.86	0.385	25.47	0.352
			1	271	25.54	0.358	25.95	0.394	25.44	0.350
			270	0	24.12	0.258	24.30	0.269	24.20	0.263
		CP-OFDM 16QAM	1	1	25.08	0.322	24.84	0.305	24.80	0.302
CP-OFDM 64QAM	1	1	23.61	0.230	23.93	0.247	23.51	0.224		

NR Band 41 (IC)										
BW (MHz)	SCS (kHz)	Modulation	RB Size	RB Offset	Conducted Output Power					
					502002 (2 510.01 MHz)		519000 (2 595.00 MHz)		535998 (2 679.99 MHz)	
					Port 1 + Port 2					
					(dB m)	(W)	(dB m)	(W)	(dB m)	(W)
20	30	CP-OFDM QPSK	1	1	25.74	0.375	25.93	0.392	25.94	0.393
			1	26	25.61	0.364	25.94	0.393	25.90	0.389
			1	49	25.70	0.372	25.91	0.390	25.96	0.394
			50	0	24.24	0.265	24.48	0.281	24.38	0.274
		CP-OFDM 16QAM	1	1	25.06	0.321	25.44	0.350	25.25	0.335
CP-OFDM 64QAM	1	1	23.75	0.237	24.07	0.255	23.96	0.249		
NR Band 41 (IC)										
BW (MHz)	SCS (kHz)	Modulation	RB Size	RB Offset	Conducted Output Power					
					503004 (2 515.02 MHz)		519000 (2 595.00 MHz)		534996 (2 674.98 MHz)	
					Port 1 + Port 2					
					(dB m)	(W)	(dB m)	(W)	(dB m)	(W)
30	30	CP-OFDM QPSK	1	1	25.90	0.389	25.83	0.383	25.93	0.392
			1	39	25.82	0.382	25.93	0.392	25.88	0.387
			1	76	25.99	0.397	25.94	0.393	25.91	0.390
			75	0	24.32	0.270	24.60	0.288	24.43	0.277
		CP-OFDM 16QAM	1	1	25.24	0.334	25.41	0.348	25.37	0.344
CP-OFDM 64QAM	1	1	23.97	0.249	24.10	0.257	23.85	0.243		
NR Band 41 (IC)										
BW (MHz)	SCS (kHz)	Modulation	RB Size	RB Offset	Conducted Output Power					
					504000 (2 520.00 MHz)		519000 (2 595.00 MHz)		534000 (2 670.00 MHz)	
					Port 1 + Port 2					
					(dB m)	(W)	(dB m)	(W)	(dB m)	(W)
40	30	CP-OFDM QPSK	1	1	25.90	0.389	25.94	0.393	25.88	0.387
			1	53	25.89	0.388	25.92	0.391	25.98	0.396
			1	104	25.87	0.386	25.97	0.395	25.91	0.390
			100	0	24.32	0.270	24.33	0.271	24.56	0.286
		CP-OFDM 16QAM	1	1	25.22	0.333	25.27	0.337	25.45	0.351
CP-OFDM 64QAM	1	1	23.75	0.237	23.90	0.245	23.91	0.246		
NR Band 41 (IC)										
BW (MHz)	SCS (kHz)	Modulation	RB Size	RB Offset	Conducted Output Power					
					505002 (2 525.01 MHz)		519000 (2 595.00 MHz)		532998 (2 664.99 MHz)	
					Port 1 + Port 2					
					(dB m)	(W)	(dB m)	(W)	(dB m)	(W)
50	30	CP-OFDM QPSK	1	1	25.76	0.377	25.95	0.394	25.71	0.372
			1	67	25.65	0.367	25.93	0.392	25.78	0.378
			1	131	25.64	0.366	25.94	0.393	25.98	0.396
			128	0	24.17	0.261	24.45	0.279	24.29	0.269
		CP-OFDM 16QAM	1	1	25.16	0.328	25.22	0.333	25.13	0.326
CP-OFDM 64QAM	1	1	23.86	0.243	23.74	0.237	25.03	0.318		

NR Band 41 (IC)										
BW (MHz)	SCS (kHz)	Modulation	RB Size	RB Offset	Conducted Output Power					
					506004 (2 530.02 MHz)		519000 (2 595.00 MHz)		531996 (2 659.98 MHz)	
					Port 1 + Port 2					
					(dB m)	(W)	(dB m)	(W)	(dB m)	(W)
60	30	CP-OFDM QPSK	1	1	25.77	0.378	25.80	0.380	25.76	0.377
			1	81	25.78	0.378	25.98	0.396	25.85	0.385
			1	160	25.71	0.372	25.93	0.392	25.94	0.393
			162	0	24.16	0.261	24.47	0.280	24.34	0.272
		CP-OFDM 16QAM	1	1	25.08	0.322	25.14	0.327	25.05	0.320
CP-OFDM 64QAM	1	1	23.81	0.240	23.81	0.240	23.59	0.229		
NR Band 41 (IC)										
BW (MHz)	SCS (kHz)	Modulation	RB Size	RB Offset	Conducted Output Power					
					508002 (2 540.01 MHz)		519000 (2 595.00 MHz)		529998 (2 649.99 MHz)	
					Port 1 + Port 2					
					(dB m)	(W)	(dB m)	(W)	(dB m)	(W)
80	30	CP-OFDM QPSK	1	1	25.76	0.377	25.81	0.381	25.75	0.376
			1	109	25.64	0.366	25.85	0.385	25.94	0.393
			1	215	25.54	0.358	25.65	0.367	25.41	0.348
			216	0	24.16	0.261	24.43	0.277	24.47	0.280
		CP-OFDM 16QAM	1	1	25.13	0.326	25.16	0.328	24.96	0.313
CP-OFDM 64QAM	1	1	23.86	0.243	23.83	0.242	23.70	0.234		
NR Band 41 (IC)										
BW (MHz)	SCS (kHz)	Modulation	RB Size	RB Offset	Conducted Output Power					
					509004 (2 545.02 MHz)		519000 (2 595.00 MHz)		528996 (2 644.98 MHz)	
					Port 1 + Port 2					
					(dB m)	(W)	(dB m)	(W)	(dB m)	(W)
90	30	CP-OFDM QPSK	1	1	25.77	0.378	25.83	0.383	25.70	0.372
			1	123	25.65	0.367	25.85	0.385	25.91	0.390
			1	243	25.49	0.354	25.97	0.395	25.24	0.334
			243	0	24.13	0.259	24.49	0.281	24.45	0.279
		CP-OFDM 16QAM	1	1	25.21	0.332	25.08	0.322	24.93	0.311
CP-OFDM 64QAM	1	1	23.89	0.245	23.85	0.243	23.66	0.232		
NR Band 41 (IC)										
BW (MHz)	SCS (kHz)	Modulation	RB Size	RB Offset	Conducted Output Power					
					510000 (2 550.00 MHz)		519000 (2 595.00 MHz)		528000 (2 640.00 MHz)	
					Port 1 + Port 2					
					(dB m)	(W)	(dB m)	(W)	(dB m)	(W)
100	30	CP-OFDM QPSK	1	1	25.70	0.372	25.76	0.377	25.81	0.381
			1	137	25.77	0.378	25.92	0.391	25.79	0.379
			1	271	25.59	0.362	25.15	0.327	25.34	0.342
			270	0	24.39	0.275	24.48	0.281	24.49	0.281
		CP-OFDM 16QAM	1	1	24.95	0.313	24.80	0.302	24.90	0.309
CP-OFDM 64QAM	1	1	23.54	0.226	23.61	0.230	23.66	0.232		

ENDC

5A-n41A (FCC)										
BW (MHz)	SCS (kHz)	Modulation	RB Size	RB Offset	Conducted Output Power					
					501204 (2 506.02 MHz)		518598 (2 592.99 MHz)		535998 (2 679.99 MHz)	
					(dB m)	(W)	(dB m)	(W)	(dB m)	(W)
20	30	DFT-S-OFDM BPSK	1	1	23.58	0.228	23.79	0.239	23.91	0.246
			1	26	23.12	0.205	23.72	0.236	23.42	0.220
			1	49	23.06	0.202	23.79	0.239	23.40	0.219
		DFT-S-OFDM QPSK	1	1	23.58	0.228	23.72	0.236	23.87	0.244
			1	26	23.10	0.204	23.66	0.232	23.39	0.218
			1	49	23.03	0.201	23.72	0.236	23.35	0.216

5A-n41A (FCC)										
BW (MHz)	SCS (kHz)	Modulation	RB Size	RB Offset	Conducted Output Power					
					502200 (2 511.00 MHz)		518598 (2 592.99 MHz)		534996 (2 674.98 MHz)	
					(dB m)	(W)	(dB m)	(W)	(dB m)	(W)
30	30	DFT-S-OFDM BPSK	1	1	23.81	0.240	23.94	0.248	24.36	0.273
			1	39	23.27	0.212	23.79	0.239	23.90	0.245
			1	76	23.73	0.236	24.05	0.254	23.67	0.233
		DFT-S-OFDM QPSK	1	1	23.76	0.238	23.90	0.245	24.31	0.270
			1	39	23.23	0.210	23.76	0.238	23.89	0.245
			1	76	23.65	0.232	24.02	0.252	23.67	0.233

5A-n41A (FCC)										
BW (MHz)	SCS (kHz)	Modulation	RB Size	RB Offset	Conducted Output Power					
					503202 (2 516.01 MHz)		518598 (2 592.99 MHz)		534000 (2 670.00 MHz)	
					(dB m)	(W)	(dB m)	(W)	(dB m)	(W)
40	30	DFT-S-OFDM BPSK	1	1	23.71	0.235	23.81	0.240	23.83	0.242
			1	53	23.24	0.211	23.81	0.240	23.95	0.248
			1	104	24.12	0.258	24.25	0.266	23.63	0.231
		DFT-S-OFDM QPSK	1	1	23.70	0.234	23.75	0.237	23.79	0.239
			1	53	23.19	0.208	23.75	0.237	23.93	0.247
			1	104	24.07	0.255	24.19	0.262	23.60	0.229

5A-n41A (FCC)										
BW (MHz)	SCS (kHz)	Modulation	RB Size	RB Offset	Conducted Output Power					
					504204 (2 521.02 MHz)		518598 (2 592.99 MHz)		532998 (2 664.99 MHz)	
					(dB m)	(W)	(dB m)	(W)	(dB m)	(W)
50	30	DFT-S-OFDM BPSK	1	1	23.83	0.242	23.62	0.230	23.39	0.218
			1	67	23.37	0.217	23.72	0.236	24.16	0.261
			1	131	23.86	0.243	24.11	0.258	23.56	0.227
		DFT-S-OFDM QPSK	1	1	23.71	0.235	23.54	0.226	23.40	0.219
			1	67	23.28	0.213	23.68	0.233	24.14	0.259
			1	131	23.81	0.240	24.09	0.256	23.53	0.225

5A-n41 (FCC)										
BW (MHz)	SCS (kHz)	Modulation	RB Size	RB Offset	Conducted Output Power					
					505200 (2 526.00 MHz)		518598 (2 592.99 MHz)		531996 (2 659.98 MHz)	
					(dB m)	(W)	(dB m)	(W)	(dB m)	(W)
60	30	DFT-S-OFDM BPSK	1	1	23.66	0.232	23.34	0.216	23.43	0.220
			1	81	23.52	0.225	23.69	0.234	23.99	0.251
			1	160	23.22	0.210	23.95	0.248	23.48	0.223
		DFT-S-OFDM QPSK	1	1	23.61	0.230	23.28	0.213	23.39	0.218
			1	81	23.47	0.222	23.61	0.230	23.94	0.248
			1	160	23.18	0.208	23.91	0.246	23.44	0.221

5A-n41A (FCC)										
BW (MHz)	SCS (kHz)	Modulation	RB Size	RB Offset	Conducted Output Power					
					507204 (2 536.02 MHz)		518598 (2 592.99 MHz)		529998 (2 649.99 MHz)	
					(dB m)	(W)	(dB m)	(W)	(dB m)	(W)
80	30	DFT-S-OFDM BPSK	1	1	23.72	0.236	23.61	0.230	24.21	0.264
			1	109	23.93	0.247	23.85	0.243	23.66	0.232
			1	215	23.30	0.214	23.57	0.228	23.55	0.226
		DFT-S-OFDM QPSK	1	1	23.66	0.232	23.53	0.225	24.14	0.259
			1	109	23.93	0.247	23.76	0.238	23.61	0.230
			1	215	23.18	0.208	23.48	0.223	23.51	0.224
5A-n41A (FCC)										
BW (MHz)	SCS (kHz)	Modulation	RB Size	RB Offset	Conducted Output Power					
					508200 (2 541.00 MHz)		518598 (2 592.99 MHz)		528996 (2 644.98 MHz)	
					(dB m)	(W)	(dB m)	(W)	(dB m)	(W)
90	30	DFT-S-OFDM BPSK	1	1	23.86	0.243	23.92	0.247	23.93	0.247
			1	123	24.08	0.256	23.82	0.241	23.61	0.230
			1	243	23.39	0.218	23.38	0.218	23.59	0.229
		DFT-S-OFDM QPSK	1	1	23.80	0.240	23.71	0.235	23.84	0.242
			1	123	24.00	0.251	23.76	0.238	23.55	0.226
			1	243	23.30	0.214	23.30	0.214	23.53	0.225
5A-n41A (FCC)										
BW (MHz)	SCS (kHz)	Modulation	RB Size	RB Offset	Conducted Output Power					
					509202 (2 546.01 MHz)		518598 (2 592.99 MHz)		528000 (2 640.00 MHz)	
					(dB m)	(W)	(dB m)	(W)	(dB m)	(W)
100	30	DFT-S-OFDM BPSK	1	1	23.81	0.240	24.12	0.258	23.80	0.240
			1	137	23.63	0.231	23.85	0.243	23.34	0.216
			1	271	23.21	0.209	23.32	0.215	23.57	0.228
		DFT-S-OFDM QPSK	1	1	23.76	0.238	23.99	0.251	23.72	0.236
			1	137	23.59	0.229	23.68	0.233	23.27	0.212
			1	271	23.16	0.207	23.27	0.212	23.51	0.224

5A-n41A (IC)										
BW (MHz)	SCS (kHz)	Modulation	RB Size	RB Offset	Conducted Output Power					
					502002 (2 510.01 MHz)		519000 (2 595.00 MHz)		535998 (2 679.99 MHz)	
					(dB m)	(W)	(dB m)	(W)	(dB m)	(W)
20	30	DFT-S-OFDM BPSK	1	1	23.64	0.231	23.66	0.232	23.97	0.249
			1	26	23.19	0.208	23.61	0.230	23.50	0.224
			1	49	23.27	0.212	23.66	0.232	23.50	0.224
		DFT-S-OFDM QPSK	1	1	23.62	0.230	23.63	0.231	23.92	0.247
			1	26	23.14	0.206	23.57	0.228	23.45	0.221
			1	49	23.23	0.210	23.62	0.230	23.43	0.220

5A-n41A (IC)										
BW (MHz)	SCS (kHz)	Modulation	RB Size	RB Offset	Conducted Output Power					
					503004 (2 515.02 MHz)		519000 (2 595.00 MHz)		534996 (2 674.98 MHz)	
					(dB m)	(W)	(dB m)	(W)	(dB m)	(W)
30	30	DFT-S-OFDM BPSK	1	1	23.73	0.236	23.87	0.244	24.40	0.275
			1	39	23.27	0.212	23.68	0.233	23.95	0.248
			1	76	23.85	0.243	24.08	0.256	23.75	0.237
		DFT-S-OFDM QPSK	1	1	23.68	0.233	23.83	0.242	24.35	0.272
			1	39	23.13	0.206	23.62	0.230	23.93	0.247
			1	76	23.84	0.242	24.04	0.254	23.71	0.235

5A-n41A (IC)										
BW (MHz)	SCS (kHz)	Modulation	RB Size	RB Offset	Conducted Output Power					
					504000 (2 520.00 MHz)		519000 (2 595.00 MHz)		534000 (2 670.00 MHz)	
					(dB m)	(W)	(dB m)	(W)	(dB m)	(W)
40	30	DFT-S-OFDM BPSK	1	1	23.81	0.240	23.75	0.237	23.85	0.243
			1	53	23.46	0.222	23.68	0.233	23.98	0.250
			1	104	24.23	0.265	24.17	0.261	23.63	0.231
		DFT-S-OFDM QPSK	1	1	23.78	0.239	23.68	0.233	23.79	0.239
			1	53	23.41	0.219	23.61	0.230	23.95	0.248
			1	104	24.18	0.262	24.13	0.259	23.62	0.230

5A-n41A (IC)										
BW (MHz)	SCS (kHz)	Modulation	RB Size	RB Offset	Conducted Output Power					
					505002 (2 525.01 MHz)		519000 (2 595.00 MHz)		532998 (2 664.99 MHz)	
					(dB m)	(W)	(dB m)	(W)	(dB m)	(W)
50	30	DFT-S-OFDM BPSK	1	1	23.67	0.233	23.58	0.228	23.42	0.220
			1	67	23.43	0.220	23.67	0.233	24.18	0.262
			1	131	23.59	0.229	24.00	0.251	23.56	0.227
		DFT-S-OFDM QPSK	1	1	23.63	0.231	23.53	0.225	23.41	0.219
			1	67	23.39	0.218	23.63	0.231	24.14	0.259
			1	131	23.54	0.226	23.97	0.249	23.56	0.227

5A-n41A (IC)										
BW (MHz)	SCS (kHz)	Modulation	RB Size	RB Offset	Conducted Output Power					
					506004 (2 530.02 MHz)		519000 (2 595.00 MHz)		531996 (2 659.98 MHz)	
					(dB m)	(W)	(dB m)	(W)	(dB m)	(W)
60	30	DFT-S-OFDM BPSK	1	1	23.67	0.233	23.47	0.222	23.46	0.222
			1	81	23.76	0.238	23.60	0.229	24.01	0.252
			1	160	23.16	0.207	23.81	0.240	23.49	0.223
		DFT-S-OFDM QPSK	1	1	23.64	0.231	23.41	0.219	23.42	0.220
			1	81	23.73	0.236	23.56	0.227	23.92	0.247
			1	160	23.11	0.205	23.77	0.238	23.44	0.221

5A-n41A (IC)										
BW (MHz)	SCS (kHz)	Modulation	RB Size	RB Offset	Conducted Output Power					
					508002 (2 540.01 MHz)		519000 (2 595.00 MHz)		529998 (2 649.99 MHz)	
					(dB m)	(W)	(dB m)	(W)	(dB m)	(W)
80	30	DFT-S-OFDM BPSK	1	1	23.76	0.238	23.55	0.226	24.24	0.265
			1	109	24.13	0.259	23.66	0.232	23.68	0.233
			1	215	23.40	0.219	23.47	0.222	23.58	0.228
		DFT-S-OFDM QPSK	1	1	23.72	0.236	23.44	0.221	24.17	0.261
			1	109	23.98	0.250	23.59	0.229	23.63	0.231
			1	215	23.37	0.217	23.40	0.219	23.51	0.224

5A-n41A (IC)										
BW (MHz)	SCS (kHz)	Modulation	RB Size	RB Offset	Conducted Output Power					
					509004 (2 545.02 MHz)		519000 (2 595.00 MHz)		528996 (2 644.98 MHz)	
					(dB m)	(W)	(dB m)	(W)	(dB m)	(W)
90	30	DFT-S-OFDM BPSK	1	1	23.77	0.238	23.81	0.240	23.92	0.247
			1	123	23.73	0.236	23.67	0.233	23.60	0.229
			1	243	23.29	0.213	23.33	0.215	23.59	0.229
		DFT-S-OFDM QPSK	1	1	23.75	0.237	23.75	0.237	23.87	0.244
			1	123	23.64	0.231	23.61	0.230	23.57	0.228
			1	243	23.24	0.211	23.30	0.214	23.53	0.225

5A-n41A (IC)										
BW (MHz)	SCS (kHz)	Modulation	RB Size	RB Offset	Conducted Output Power					
					510000 (2 550.00 MHz)		519000 (2 595.00 MHz)		528000 (2 640.00 MHz)	
					(dB m)	(W)	(dB m)	(W)	(dB m)	(W)
100	30	DFT-S-OFDM BPSK	1	1	23.74	0.237	24.05	0.254	23.81	0.240
			1	137	23.51	0.224	23.67	0.233	23.32	0.215
			1	271	23.21	0.209	23.50	0.224	23.58	0.228
		DFT-S-OFDM QPSK	1	1	23.74	0.237	23.98	0.250	23.74	0.237
			1	137	23.46	0.222	23.61	0.230	23.30	0.214
			1	271	23.15	0.207	23.45	0.221	23.52	0.225

4. Occupied Bandwidth

4.1. Limit

CFR 47, Section FCC §2.1049 and IC RSS-Gen Issue 5 6.7.

4.2. Test Procedure

FCC

The test follows section 5.4.4 of ANSI C63.26-2015.

- a. The spectrum analyzer center frequency is set to the nominal EUT channel center frequency. The frequency span for the spectrum analyzer shall be set wide enough to capture all modulation products including the emission skirts (typically a span of $1.5 \times \text{OBW}$ is sufficient).
- b. The nominal IF filter 3 dB bandwidth (RBW) shall be in the range of 1 % to 5 % of the anticipated OBW, and the VBW shall be set $\geq 3 \times \text{RBW}$.
- c. Set the reference level of the instrument as required to prevent the signal amplitude from exceeding the maximum spectrum analyzer input mixer level for linear operation. See guidance provided in 4.2.3.
- d. Set the detection mode to peak, and the trace mode to max-hold.
- e. If the instrument does not have a 99 % OBW function, recover the trace data points and sum directly in linear power terms. Place the recovered amplitude data points, beginning at the lowest frequency, in a running sum until 0.5 % of the total is reached. Record that frequency as the lower OBW frequency. Repeat the process until 99.5 % of the total is reached and record that frequency as the upper OBW frequency. The 99 % power OBW can be determined by computing the difference between these two frequencies.
- f. The OBW shall be reported and plot(s) of the measuring instrument display shall be provided with the test report. The frequency and amplitude axis and scale shall be clearly labeled. Tabular data can be reported in addition to the plot(s).

IC

The following conditions shall be observed for measuring the occupied bandwidth and x dB bandwidth:

- The transmitter shall be operated at its maximum carrier power measured under normal test conditions.
- The span of the spectrum analyzer shall be set large enough to capture all products of the modulation process, including the emission skirts, around the carrier frequency, but small enough to avoid having other emissions (e.g. on adjacent channels) within the span.
- The detector of the spectrum analyzer shall be set to “Sample”. However, a peak, or peak hold, may be used in place of the sampling detector since this usually produces a wider bandwidth than the actual bandwidth (worst-case measurement). Use of a peak hold (or “Max Hold”) may be necessary to determine the occupied / x dB bandwidth if the device is not transmitting continuously.
- The resolution bandwidth (RBW) shall be in the range of 1 % to 5 % of the actual occupied / x dB bandwidth and the video bandwidth (VBW) shall not be smaller than three times the RBW value. Video averaging is not permitted.

Note: It may be necessary to repeat the measurement a few times until the RBW and VBW are in compliance with the above requirement.

For the 99 % emission bandwidth, the trace data points are recovered and directly summed in linear power level terms. The recovered amplitude data points, beginning at the lowest frequency, are placed in a running sum until 0.5 % of the total is reached, and that frequency recorded. The process is repeated for the highest frequency data points (starting at the highest frequency, at the right side of the span, and going down in frequency). This frequency is then recorded. The difference between the two recorded frequencies is the occupied bandwidth (or the 99 % emission bandwidth).

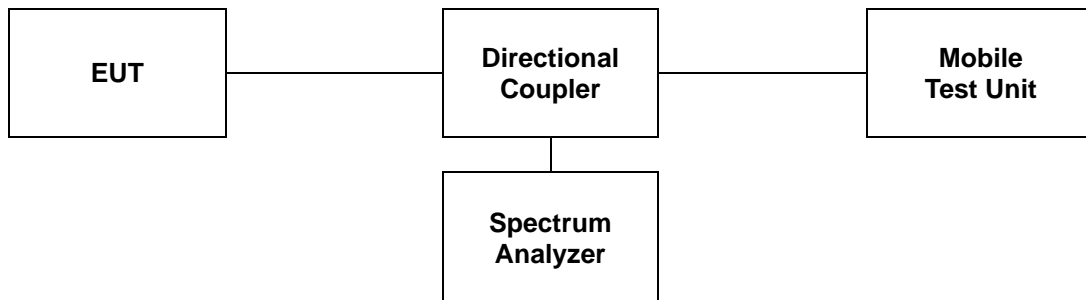

4.3 Test Results

Ambient temperature : (23 ± 1) °C
 Relative humidity : 47 % R.H.

SISO

Band	SCS (kHz)	BW (MHz)	Frequency (MHz)	Occupied Bandwidth (MHz)				
				DFT-S-OFDM BPSK	DFT-S-OFDM QPSK	DFT-S-OFDM 16QAM	CP-OFDM QPSK	CP-OFDM 16QAM
41 (FCC)	30	20	2 592.99	17.902	17.942	17.942	18.222	18.262
		30		26.793	26.793	26.793	27.752	27.812
		40		35.964	36.044	36.124	38.042	38.122
		50		45.854	45.954	45.754	47.552	47.652
		60		58.022	58.022	58.022	57.902	57.902
		80		76.883	77.043	76.883	77.682	77.363
		90		86.494	86.673	86.673	87.033	87.393
		100		96.304	96.304	96.104	97.303	97.303
Band	SCS (kHz)	BW (MHz)	Frequency (MHz)	Occupied Bandwidth (MHz)				
				DFT-S-OFDM BPSK	DFT-S-OFDM QPSK	DFT-S-OFDM 16QAM	CP-OFDM QPSK	CP-OFDM 16QAM
41 (IC)	30	20	2 595.0	17.862	17.902	17.942	18.262	18.222
		30		26.793	26.733	26.793	27.812	27.812
		40		35.964	35.964	35.964	38.042	38.202
		50		45.754	45.954	45.854	47.652	47.652
		60		58.022	58.022	58.022	58.022	57.902
		80		77.203	77.043	76.883	77.522	77.363
		90		86.673	86.673	86.673	87.393	87.393
		100		96.104	96.304	96.304	97.303	97.303

MIMO

Band	SCS (kHz)	BW (MHz)	Frequency (MHz)	Occupied Bandwidth (MHz)			
				CP-OFDM QPSK		CP-OFDM 16QAM	
				Port 1	Port 2	Port 1	Port 2
41 (FCC)	30	20	2 592.99	18.222	18.222	18.262	18.302
		30		27.872	27.752	27.872	27.752
		40		37.962	38.122	37.962	38.042
		50		47.652	47.552	47.552	47.652
		60		58.022	58.022	58.022	57.902
		80		77.522	77.363	77.522	77.363
		90		87.572	87.393	87.393	87.393
		100		97.502	97.103	97.502	97.303
Band	SCS (kHz)	BW (MHz)	Frequency (MHz)	Occupied Bandwidth (MHz)			
				CP-OFDM QPSK		CP-OFDM 16QAM	
				Port 1	Port 2	Port 1	Port 2
41 (IC)	30	20	2 595.0	18.222	18.222	18.262	18.302
		30		27.812	27.752	27.872	27.752
		40		38.042	38.202	37.962	37.962
		50		47.652	47.652	47.752	47.552
		60		58.142	58.022	58.022	58.022
		80		77.522	77.363	77.522	77.363
		90		87.572	87.393	87.393	87.393
		100		97.502	97.303	97.702	97.303

- Test plots

NR band 41 (FCC)_SISO

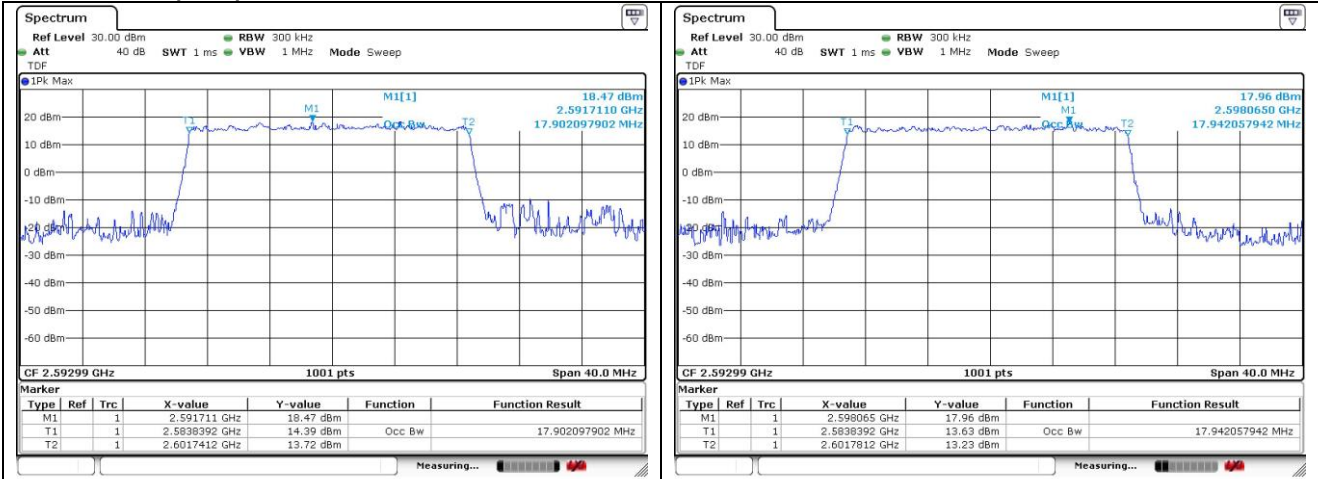

20 MHz DFT-S-OFDM BPSK

20 MHz DFT-S-OFDM QPSK

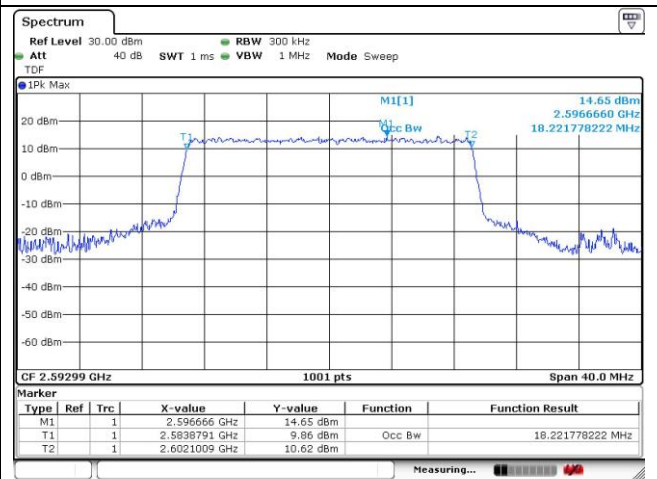
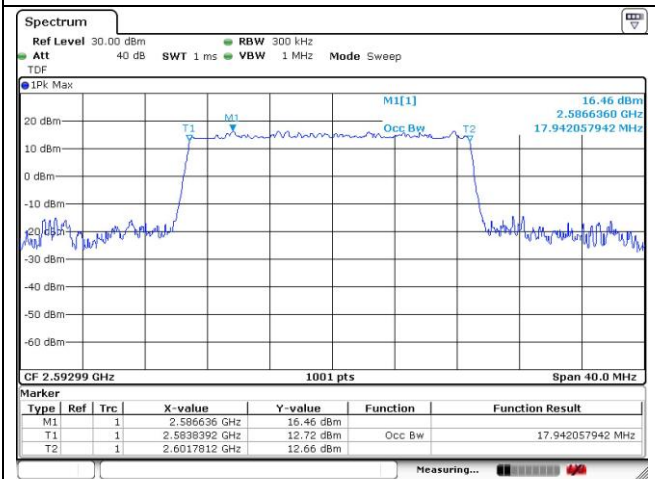

20 MHz DFT-S-OFDM 16QAM

20 MHz CP-OFDM QPSK

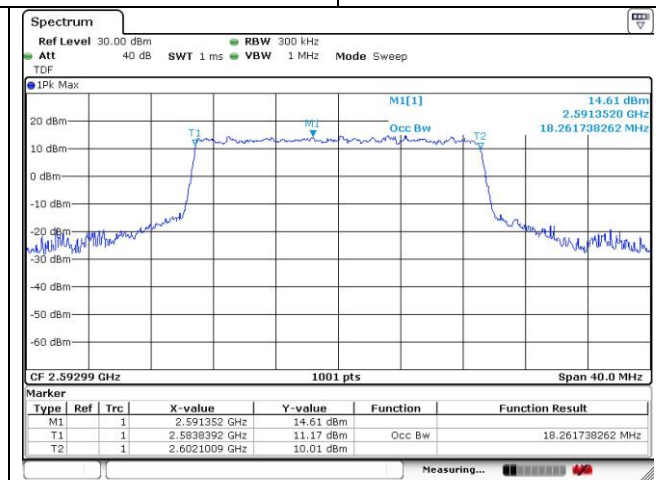

20 MHz CP-OFDM 16QAM

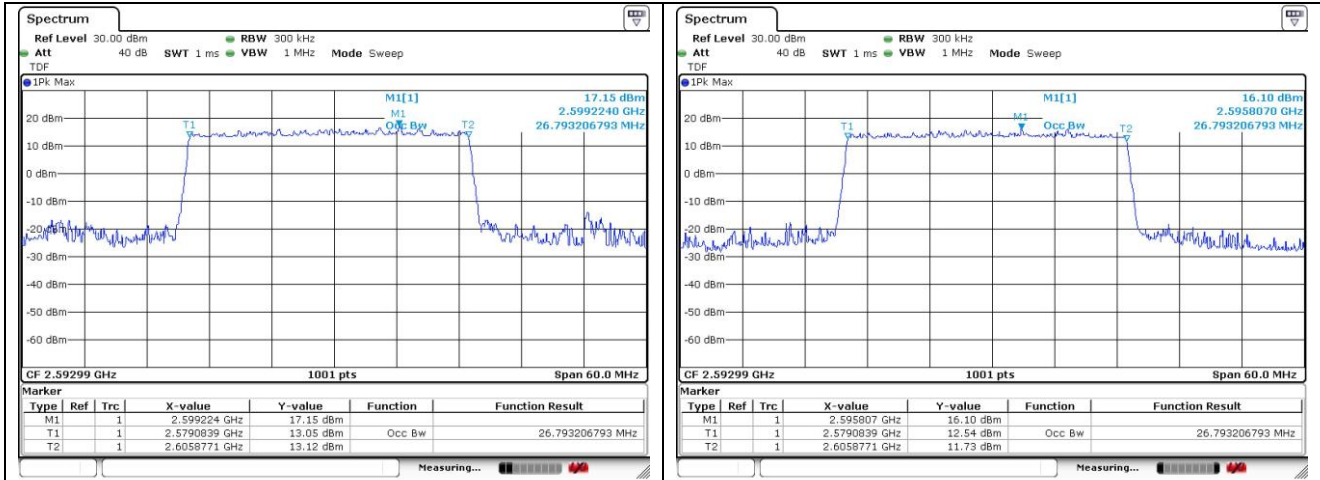

30 MHz DFT-S-OFDM BPSK

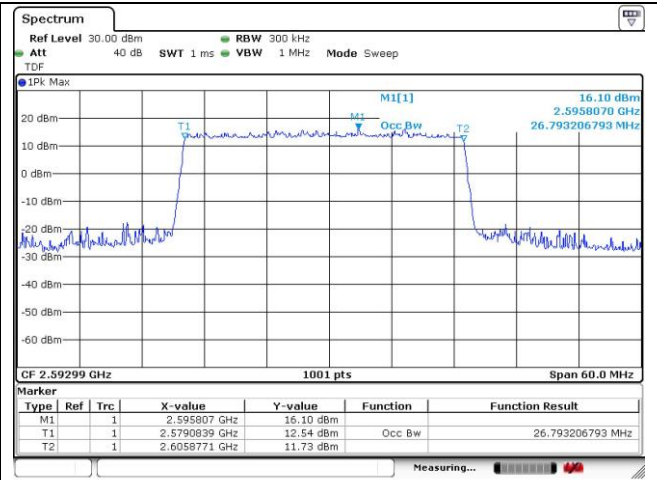

30 MHz DFT-S-OFDM QPSK

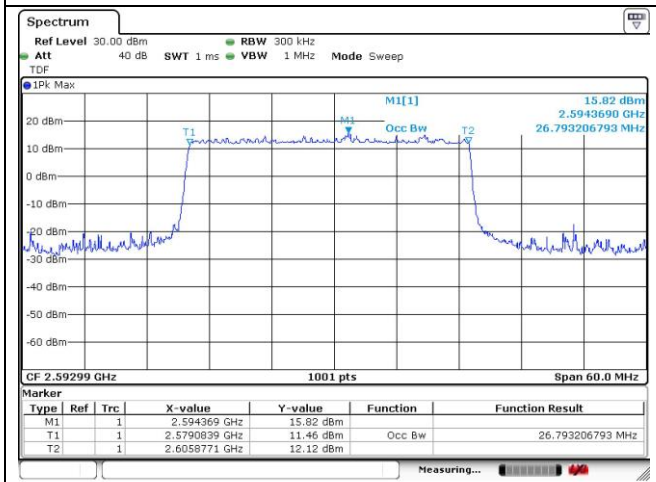

30 MHz DFT-S-OFDM 16QAM

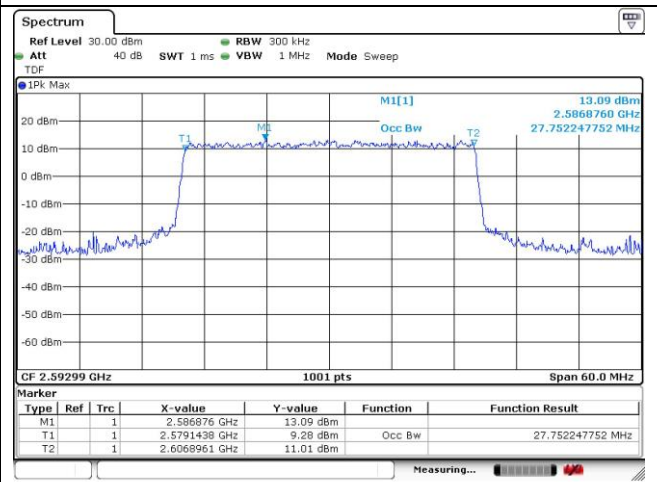

30 MHz CP-OFDM QPSK

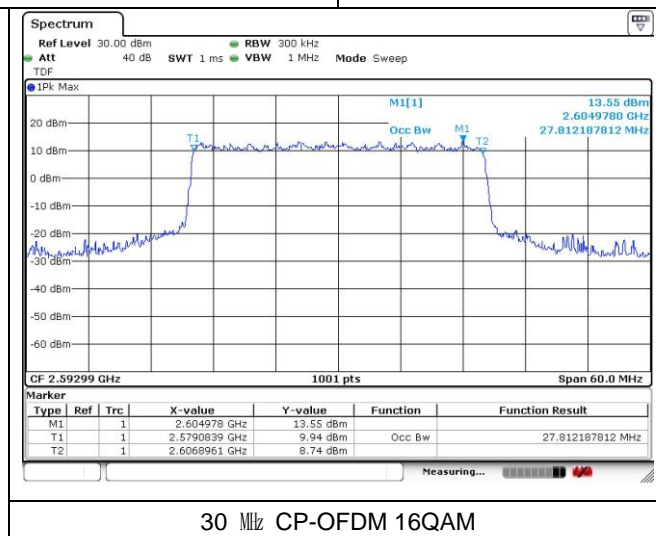

30 MHz CP-OFDM 16QAM

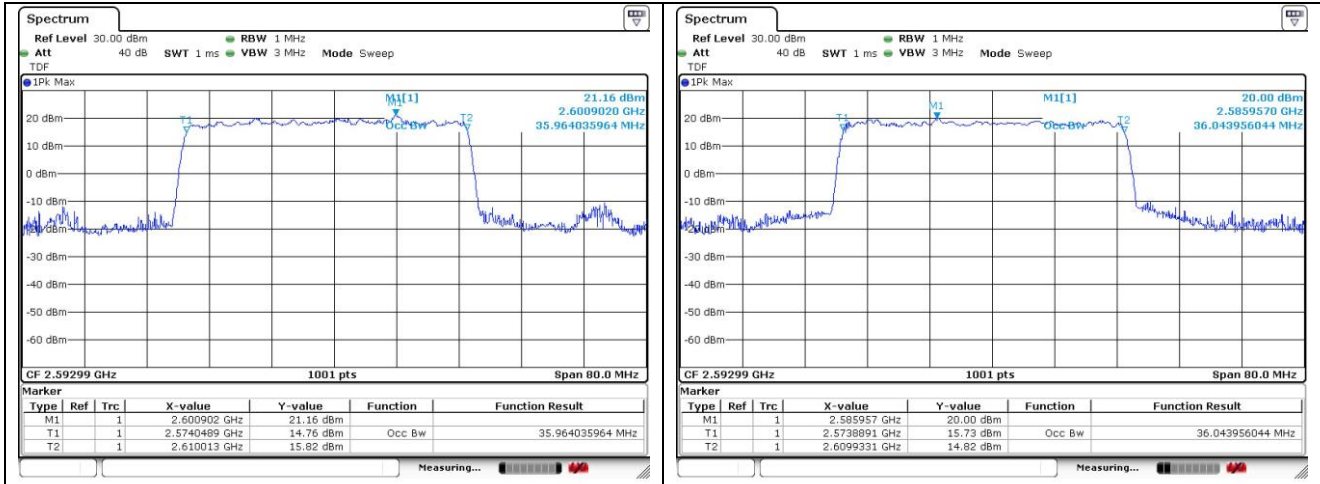

40 MHz DFT-S-OFDM BPSK

40 MHz DFT-S-OFDM QPSK

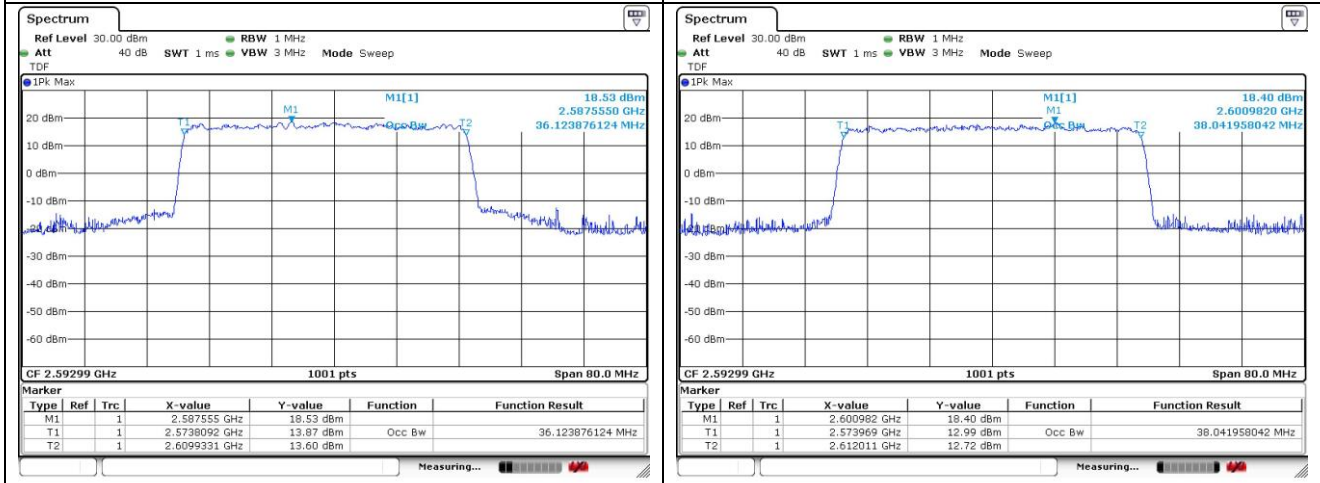

40 MHz DFT-S-OFDM 16QAM

40 MHz CP-OFDM QPSK

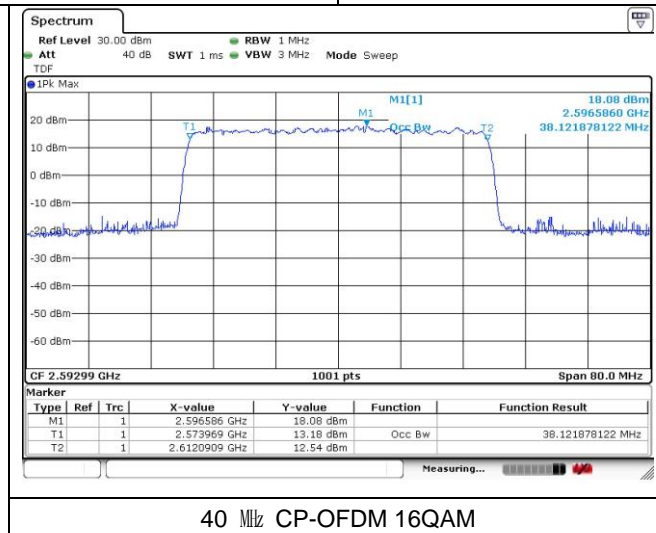

40 MHz CP-OFDM 16QAM

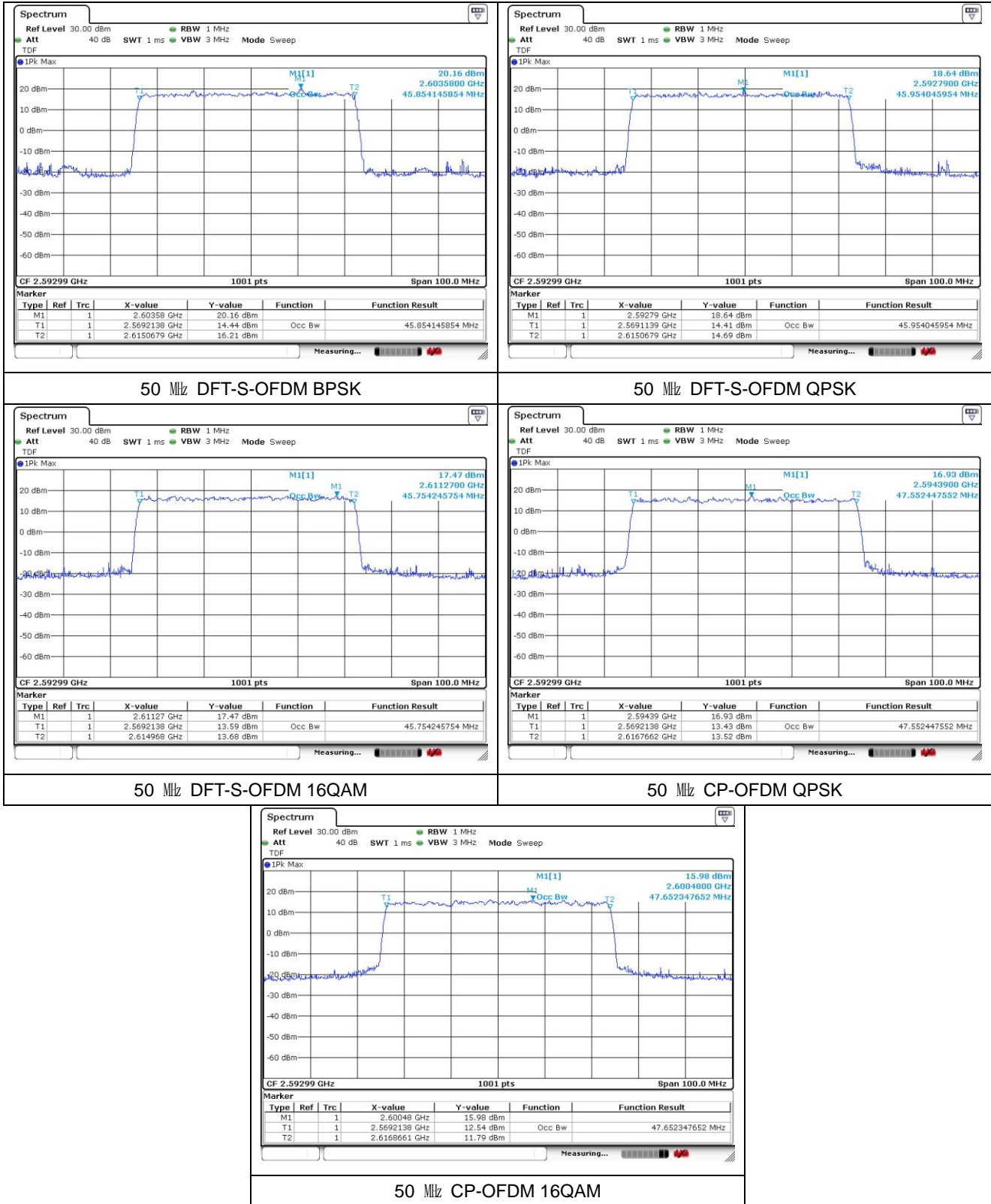

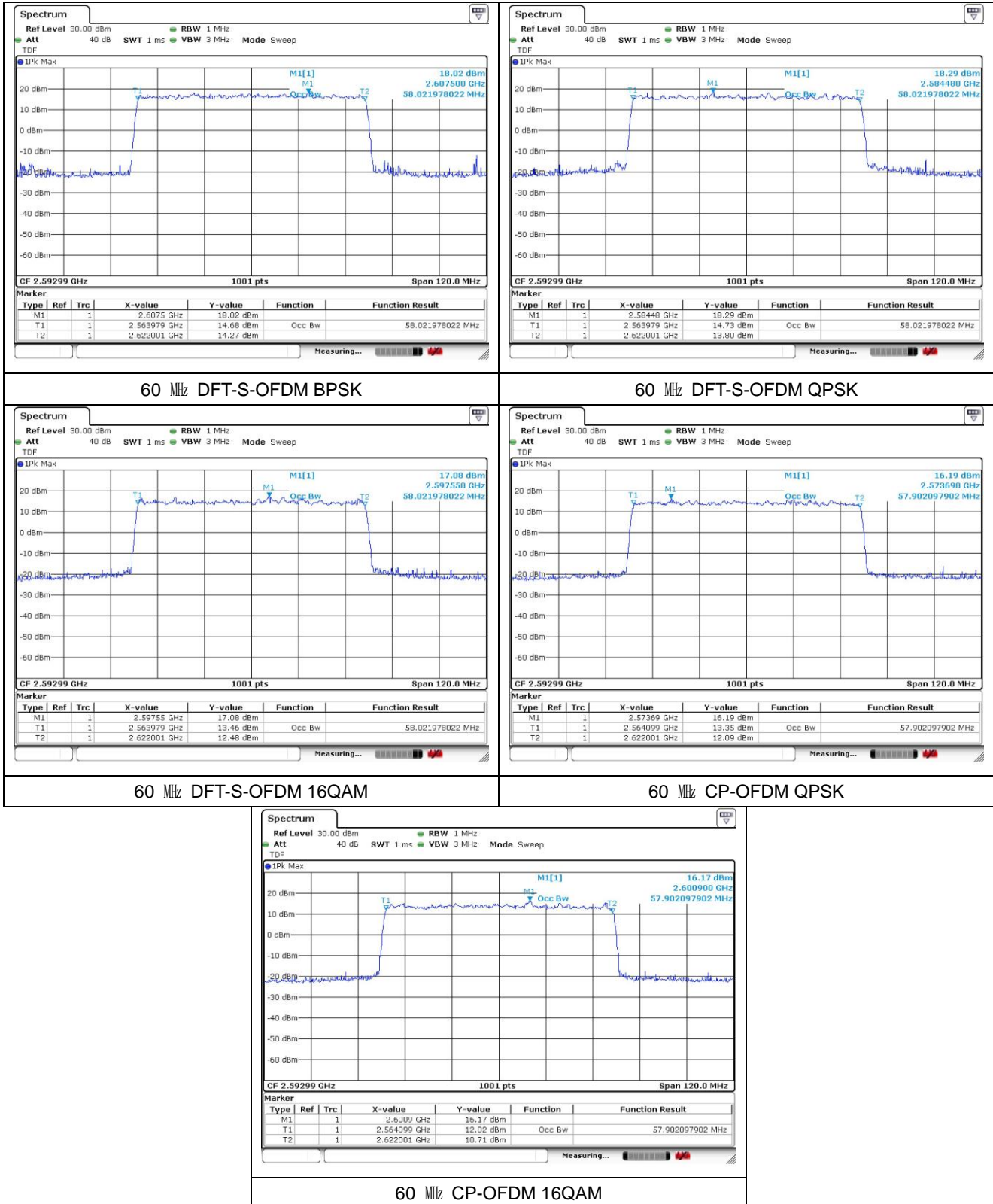

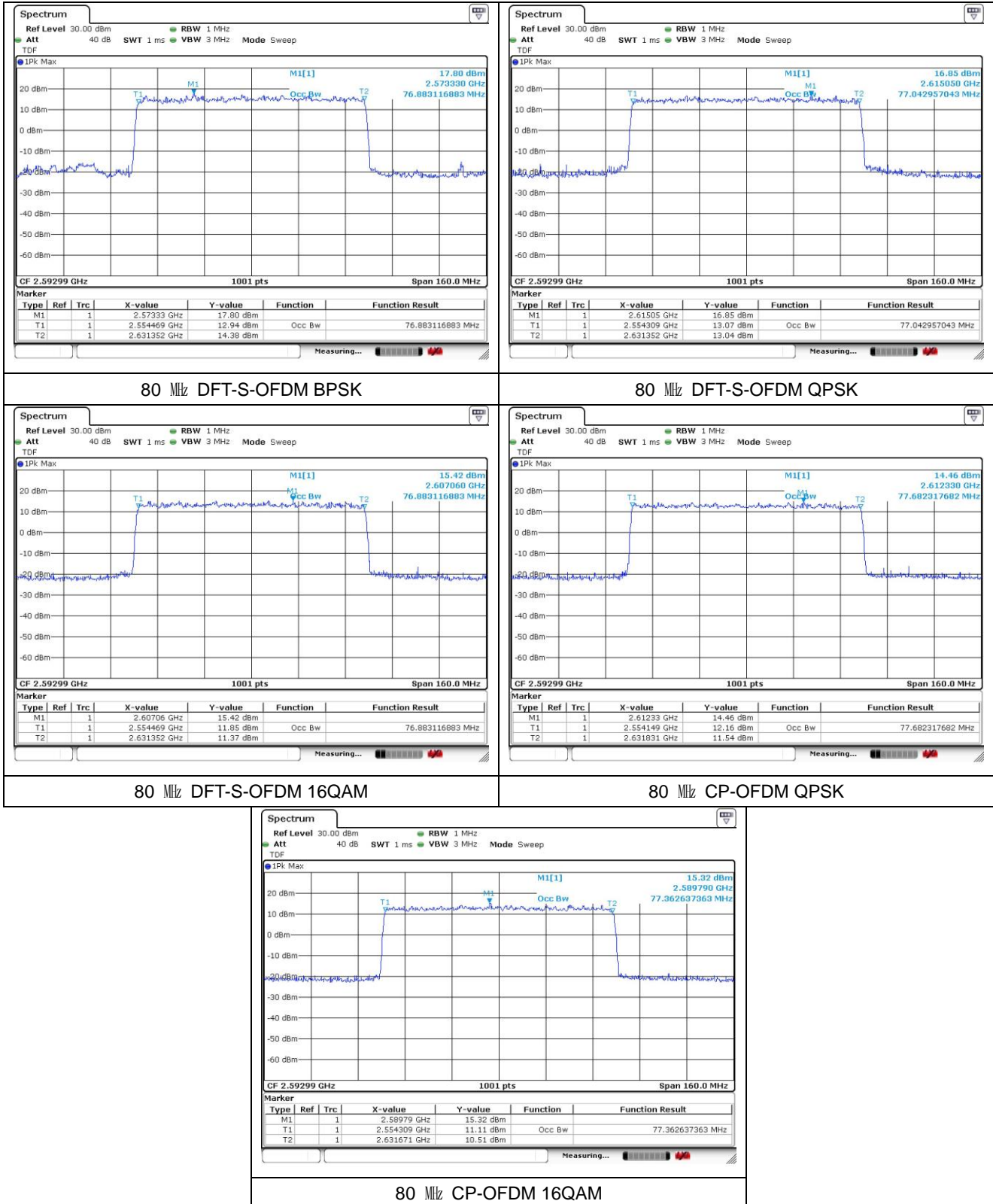

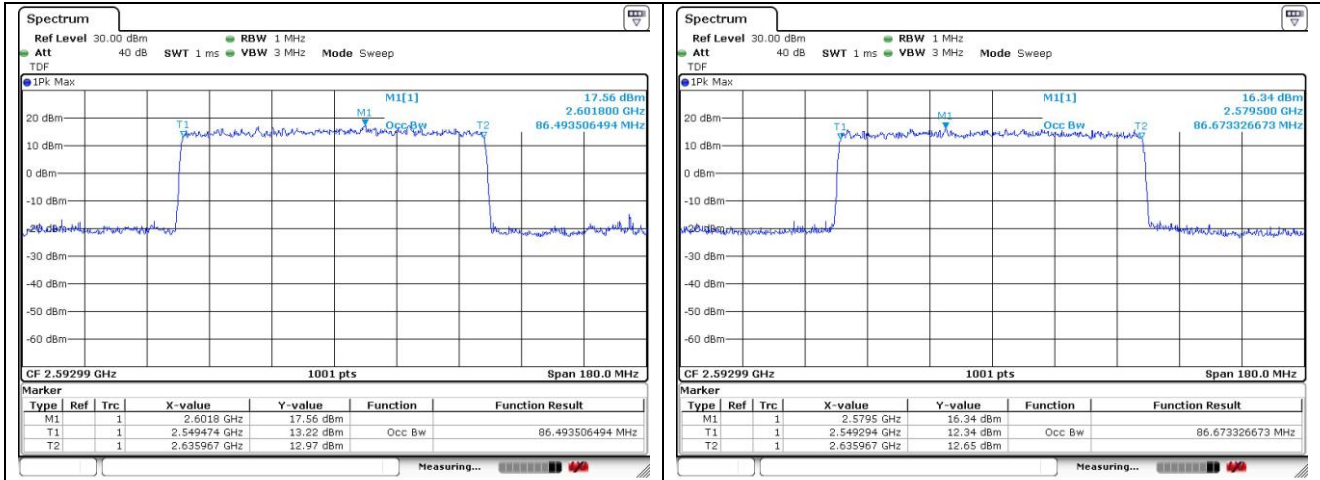

90 MHz DFT-S-OFDM BPSK

90 MHz DFT-S-OFDM QPSK

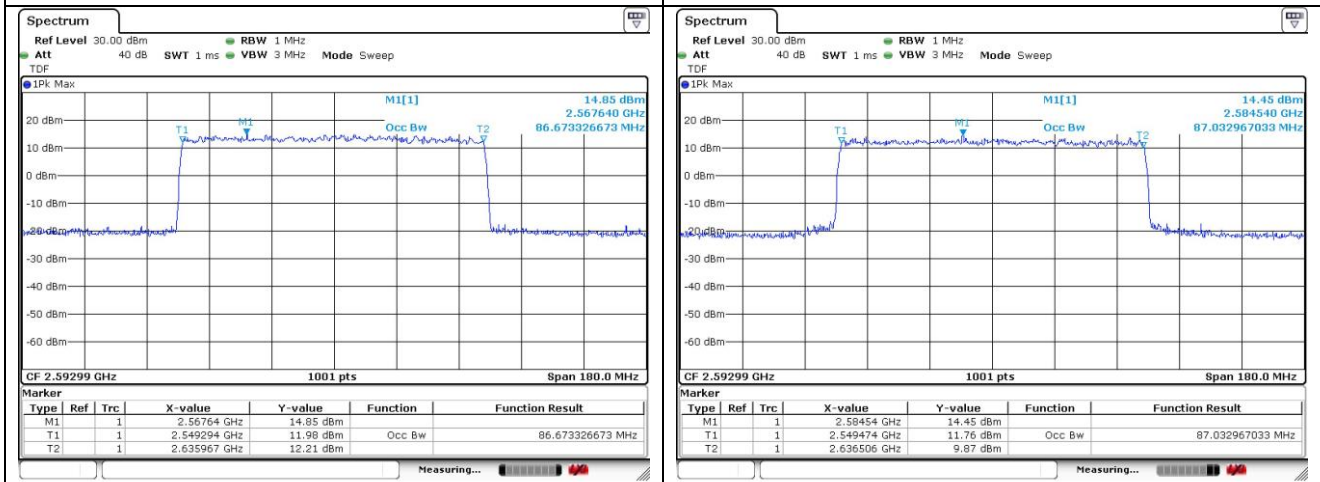

90 MHz DFT-S-OFDM 16QAM

90 MHz CP-OFDM QPSK

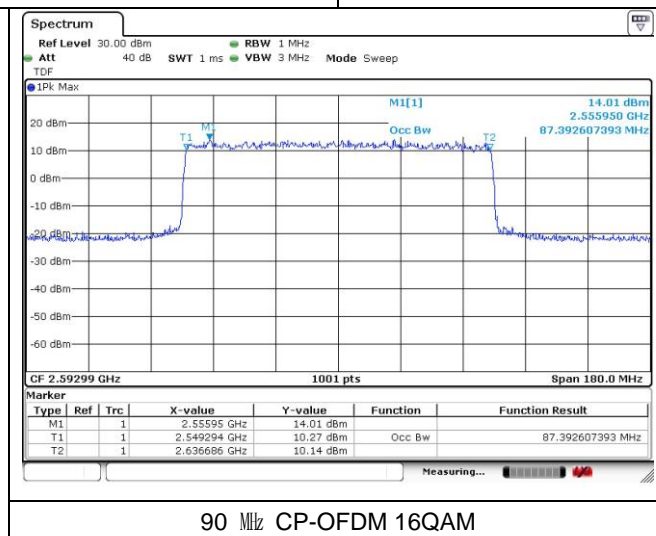

90 MHz CP-OFDM 16QAM

