

## ***EVALUATION REPORT*** ***for Certification (Class II Permissive Change)***

**Applicant: LG Electronics USA.**

**1000 Sylvan Avenue,**

**Englewood Cliffs New Jersey United States 07632**

**Attn : Kyung-Su Han / Director**

**Date of Issue: Feb. 28, 2019**

**Order Number: GETEC-C1-19-132**

**Test Report Number: GETEC-E3-19-001**

**Test Site: GUMI UNIVERSITY EMC CENTER**

**CAB Designation Number: KR0033**

**RESPONSIBLE PARTY : LG Electronics USA.**

**ADDRESS : 1000 Sylvan Avenue Englewood Cliffs NJ 07632, U.S.A.**

**CONTACT PERSON : Mr. Kyung-Su Han / Director**

**Rule Part(s) : FCC Part 15 Subpart C Intentional Radiator § 15.209**

**Equipment Class : Digital Transmission System(DTS)**

**EUT Type : Premium Magic Remote**

**Type of Authority : Certification (Class II Permissive Change)**

**Model Name : AN-PM19BA**

**Trade Name : LG**

**This equipment has been shown to be in compliance with the applicable technical standards as indicated in the measurement report and was tested in accordance with the measurement procedures specified in ANSI C63.4 (2014)**

**I attest to the accuracy of data. All measurements reported herein were performed by me or were made under my supervision and are correct to the vest of my knowledge and belief. I assume full responsibility for the completeness of these measurements and vouch for the qualifications of all persons taking them.**

**Tested by,**

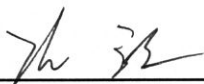

**Hyun Kim, Senior Engineer  
GUMI UNIVERSITY EMC CENTER**

**Reviewed by,**



**Jae-Hoon Jeong, Technical Manager  
GUMI UNIVERSITY EMC CENTER**



## CONTENTS

1. GENERAL INFORMATION .....	3
2. INTRODUCTION .....	4
3. PRODUCT INFORMATION .....	5
3.1 DESCRIPTION OF EUT.....	5
3.2 SUPPORT EQUIPMENT / CABLES USED .....	6
3.3 MODIFICATION ITEM(S).....	6
4. DESCRIPTION OF TESTS.....	7
4.1 TEST CONDITION.....	7
4.2 CONDUCTED EMISSION .....	8
4.3 RADIATED EMISSION.....	9
5. RADIATED EMISSION .....	10
5.1 OPERATING ENVIRONMENT .....	10
5.2 TEST SET-UP .....	10
5.3 MEASUREMENT UNCERTAINTY.....	10
5.4 LIMIT .....	11
5.5 TEST EQUIPMENT USED.....	12
5.6 TEST DATA FOR RADIATED EMISSION.....	12
6. SAMPLE CALCULATIONS.....	16
6.1 EXAMPLE 1 : .....	16
6.2 EXAMPLE 2 : .....	16
7. RECOMMENDATION & CONCLUSION.....	17
APPENDIX A – ATESTSTATION STATEMENT	
APPENDIX B – INFORMATION OF CLASS II PERMISSIVE CHANGE	
APPENDIX C – TEST SET-UP PHOTOGRAPHS	
APPENDIX D – EXTERNAL PHOTOGRAPHS	
APPENDIX E – INTERNAL PHOTOGRAPHS	
APPENDIX F – SCHEMATIC DIAGRAM	
APPENDIX G – PART LIST	





*Scope: Measurement and determination of electromagnetic emissions (EME) of radio frequency devices including intentional and / or unintentional radiators for compliance with technical rules and regulations of the Federal Communications Commission.*

## 1. General Information

**Applicant: LG Electronics USA.**

**Applicant Address: 1000 Sylvan Avenue, Englewood Cliffs, New Jersey United States 07632**

**Manufacturer: LG Electronics Inc.**

**Manufacturer Address: 222 LG-ro, Jinwi-myeon, Pyeongaek-si, Gyeonggi-do 451-713, Korea**

**Contact Person: Kyung-Su Han/ Director**

**Telephone Number: +201-408-9181**

**Fax Number: +858-635-5378**

- **FCC ID** BEJPM19BA
- **EUT Type** Premium Magic Remote
- **Equipment Class** Digital Transmission System(DTS)
- **Model Name** AN-PM19BA
- **Trade Name** LG
- **Serial Number** Prototype
- **Rule Part(s)** FCC Part 15 Subpart C Intentional Radiator § 15.209
- **Type of Authority** Certification
- **Test Procedure(s)** ANSI C63.4 (2014)
- **Dates of Test** Feb. 27, 2019
- **Place of Test**  
**GUMI UNIVERSITY EMC CENTER**  
(FCC Test Firm Registration Number: 269701)  
37 Yaeun-ro, Gumi-si, Gyeongsangbuk-do, 730-711, Republic of Korea.
- **Test Report Number** GETEC-E3-19-001
- **Date of Issue** Feb. 28, 2019





## 2. Introduction

The measurement procedure described in American National Standard for Methods of Measurement of Radio-Nose Emissions From Low-Voltage Electrical and Electronic Equipment in the Range of 9 kHz to 40 GHz (ANSI C63.4-2014) was used in determining radiated and conducted emissions emanating from **LG Electronics USA**.

### **Premium Magic Remote (Model Name: AN-PM19BA)**

These measurement tests were conducted at **GUMI UNIVERSITY EMC CENTER**

The site address is 37 Yaeun-ro, Gumi-si, Gyeongsangbuk-do, 730-711, Republic of Korea.

This test site is one of the highest point of Gumi UNIVERSITY at about 200 km away from Seoul city and 40 km away from Daegu city. It is located in the valley surrounded by mountains in all directions where ambient radio signal conditions are quiet and a favorable area to measure the radio frequency interference on open field test site for the computing and ISM devices manufactures. The detailed description of the measurement facility was found to be in compliance with the requirements of §2.948 according to ANSI C63.4 (2014)

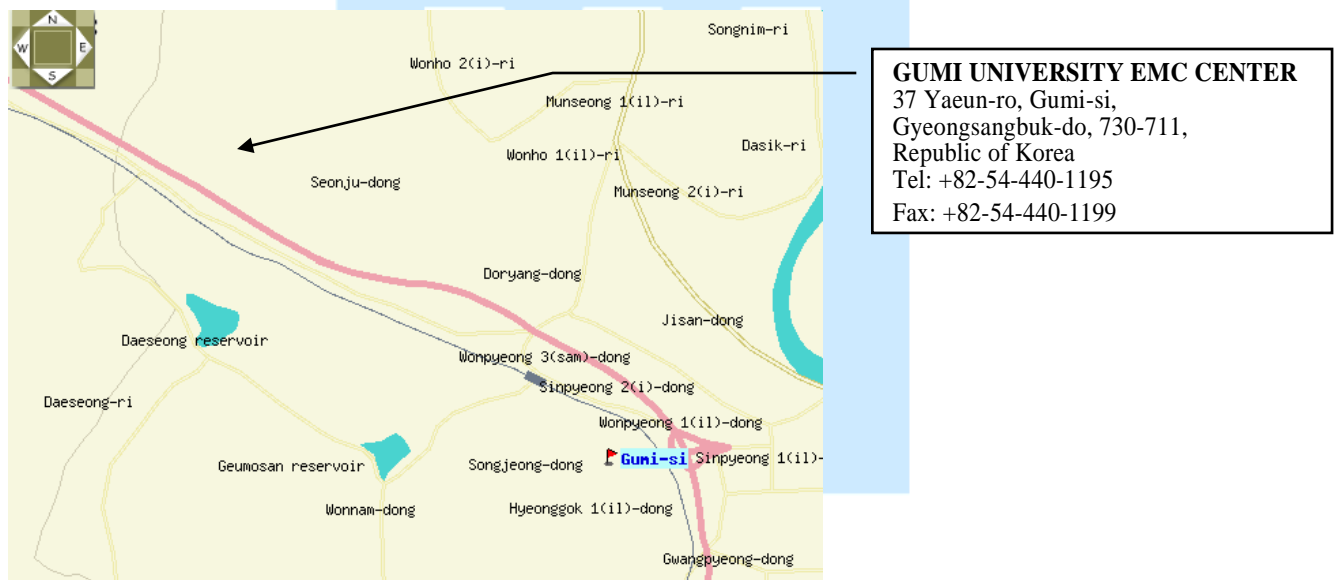

Fig 1. The map above shows the Gumi UNIVERSITY in vicinity area.



### 3. Product Information

#### 3.1 Description of EUT

The Equipment under Test (EUT) is the **LG Electronics USA. Premium Magic Remote**  
(Model Name: AN-PM19BA) FCC ID.: BEJPM19BA

- Equipment	: Premium Magic Remote
- Model name	: AN-PM19BA
- Brand name	: LG Electronics Inc.
- Serial number	: Proto type
- Electrical Rating	: DC 3.0 V('AAA' Battery x2)
- Channel Separations	: 2 MHz
- Type of Modulation	: GFSK
- Type of Technique	: Bluetooth Low Energy
- Frequency range	: 2 402 MHz ~ 2480 MHz
- Number of channel	: 40
- Antenna Type	: PCB Chip antenna
- Type of chain	: One
- Antenna specification	: Manufacturer : Partron Antenna type : PCB Chip antenna Peak Gain : -3.94 dBi
- Hardware version	: PNCFA1431A
- Software version	: 17354
- Test Software version	: Realtek Bluetooth MP Tool v2.0.1





### 3.2 Support Equipment / Cables used

#### 3.2.1 Used Support Equipment

Description	Manufacturer	Model Name	S/N & FCC ID.
Premium Magic Remote	LG Electronics Inc.	AN-PM19BA	S/N: None FCC ID.: BEJPM19BA
LED TV	LG Electronics Inc.	49SM8600PLA	S/N: None FCC ID.: None

See "Appendix C – Test Setup Photographs" for actual system test set-up

#### 3.2.2 System configuration

Description	Manufacturer	Model Name	S/N & FCC ID.
-	-	-	-

#### 3.2.3 Used Cable(s)

Cable Name	Condition	Description
-	-	-

### 3.3 Modification Item(s)

- None





## 4. Description of tests

### 4.1 Test Condition

The EUT was installed, arranged and operated in a manner that is most representative of equipment as typically used. The measurements were carried out while varying operating modes and cable positions within typically arrangement to determine maximum emission level.

The test conditions of the noted test mode(s) in this test report are;

- Test Voltage: DC 3 V ('AAA' Battery x2) / Conducted test was skip.
- Test Mode(s)
  - . RF Communication mode
- Operating test setting
  - . The EUT was communication via Bluetooth to LED TV.

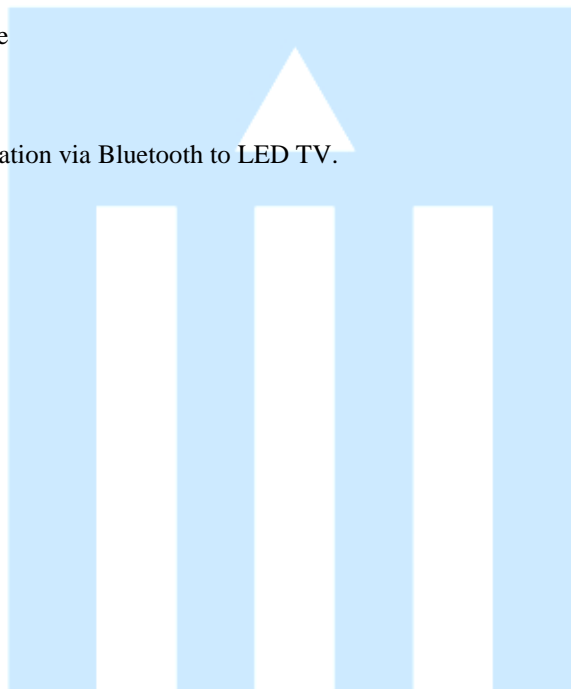



## 4.2 Conducted Emission

The Line conducted emission test facility is inside a 4 m × 8 m × 2.5 m shielded enclosure. (FCC Test Film Registration No.: 269701)

The EUT was placed on a non-conducting 1.0 m by 1.5 m table, which is 0.4 m in height and 0.8 m away from the vertical wall of the shielded enclosure.

The EUT is powered from the Rohde & Schwarz LISN (ENV216) and the support equipment is powered from the Rohde & Schwarz LISN (ENV216). Powers to the LISN are filtered by high-current high insertion loss power line filter.

Sufficient time for EUT, support equipment, and test equipment was allowed in order for them to warm up to their normal operating condition.

The RF output of the LISN was connected to the EMI test receiver (Rohde & Schwarz, ESCI).

Exploratory measurements were conducted to identify the highest emission by operating the EUT in a range of typical modes of operation, cable positions, system configuration and arrangement.

Based on exploratory measurements, the final measurements were conducted at the worst test conditions.

Exploratory measurements were scanned using Peak mode of EMI Test receiver from 150 kHz to 30 MHz with 20 ms sweep time. The final measurements were measured with Quasi-Peak and Average mode.

The bandwidth of EMI Test Receiver was set to 9 kHz. Interface cables were connected to the available interface ports of the test unit. Excess cable lengths were bundled at center with 30 cm ~ 40 cm.

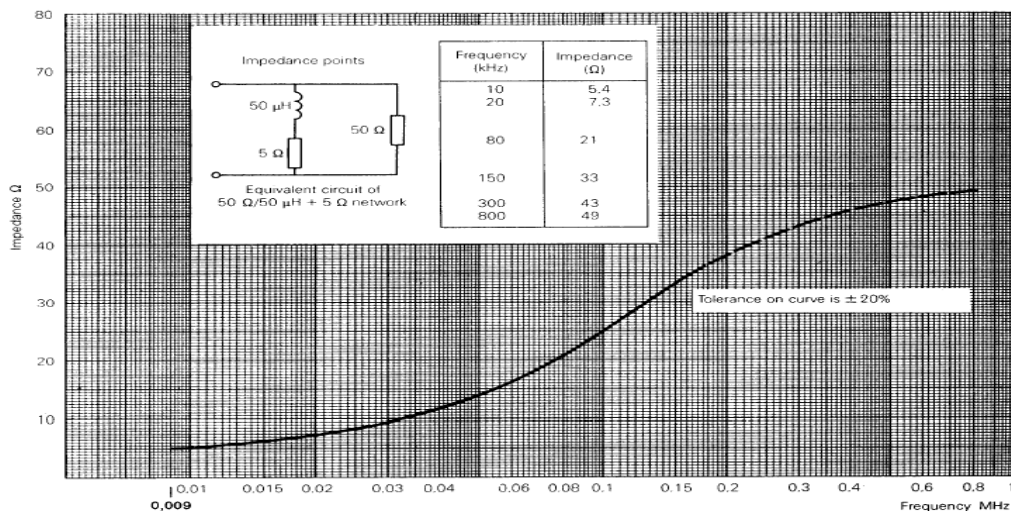

Fig 2. Impedance of LISN





### 4.3 Radiated Emission

Exploratory Radiated measurements were conducted at the 3 m or 10 m semi anechoic chamber in order to identify the highest emission by operating the EUT in a range of typical modes of operation, cable positions, system configuration and arrangement.

Based on exploratory measurements, the final measurements were conducted at the worst test conditions.

Final measurements of below 1 GHz were made at 3 m or 10 m Chamber (FCC Test Firm Registration No.: 269701) or Open area test site (FCC Test Firm Registration No.: 269701) that complies with CISPR 16/ANSI C63.4.

Above 1 GHz final measurements were conducted at the 3m Chamber (FCC Test Firm Registration No.: 269701) only.

For measurements above 1GHz, the bottom side of 3 m chamber was installed with absorbers in order to meet SVSWR Limit.

Exploratory measurements were scanned using Peak mode of EMI Test receiver and final measurements were measured with Quasi-Peak mode (Below 1 GHz) and Peak & Average mode (Above 1 GHz).

The measurements were performed by rotating the EUT 360° and adjusting the receive antenna height from 1.0 m to 4.0 m. All frequencies were investigated in both horizontal and vertical antenna polarity.

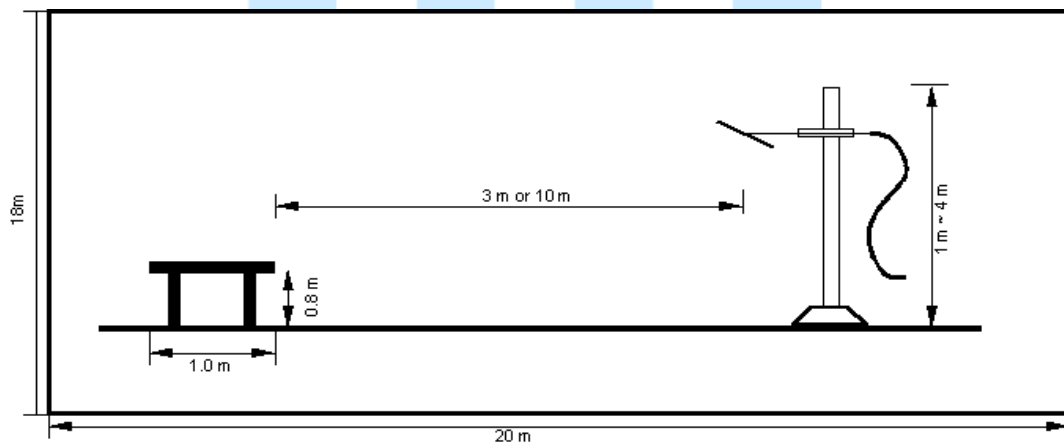

Fig 3. Dimensions of test site (Below 1 GHz)

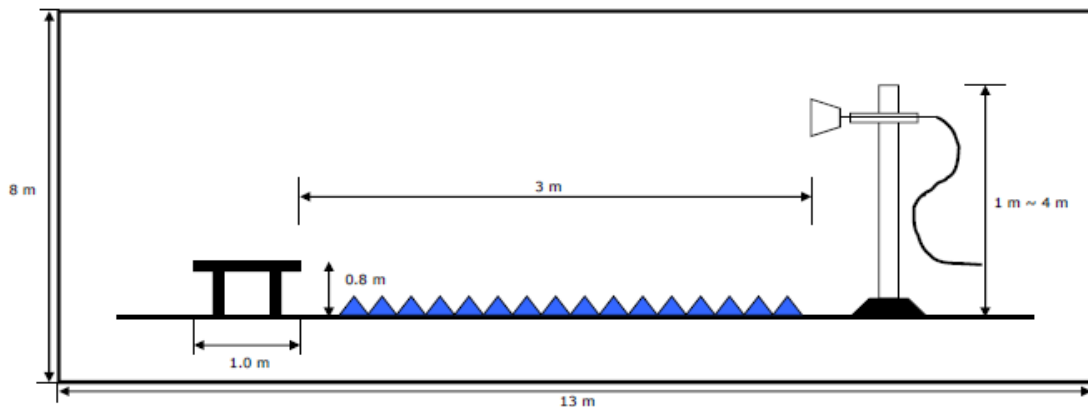

Fig 4. Dimensions of test site (Above 1 GHz)





## 5. Radiated Emission

### 5.1 Operating Environment

Temperature : 20.6 °C  
 Relative Humidity : 42.7 % R.H.

### 5.2 Test Set-up

A preliminary and final measurement was at 3 m & 10 m anechoic chamber.  
 The EUT was placed on a non-conductive turntable approximately 1.0 m above the ground plane.  
 The turntable with EUT was rotated 360°, and the antenna was varied in height between 1.0 m and 4.0 m in order to determine the maximum emission levels.  
 This procedure was performed for both horizontal and vertical polarization of the receiving antenna.

### 5.3 Measurement Uncertainty

The measurement uncertainty was calculated in accordance with ISO “Guide to the expression of uncertainty in measurement”.

Test Items(3 m Anechoic Chamber)	Uncertainty	Remark
Radiated emission (30 MHz ~ 300 MHz, 3 m, Vertical)	5.14 dB	Confidence level of approximately 95 % (k = 2)
Radiated emission (30 MHz ~ 300 MHz, 3 m, Horizontal)	5.10 dB	Confidence level of approximately 95 % (k = 2)
Radiated emission (300 MHz ~ 1 000 MHz, 3 m, Vertical)	6.05 dB	Confidence level of approximately 95 % (k = 2)
Radiated emission (300 MHz ~ 1 000 MHz, 3 m, Horizontal)	5.19 dB	Confidence level of approximately 95 % (k = 2)
Radiated emission (1 000 MHz ~ 6 000 MHz, 3 m)	5.77 dB	Confidence level of approximately 95 % (k = 2)
Radiated emission (1 000 MHz ~ 18 000 MHz, 3 m)	5.77 dB	Confidence level of approximately 95 % (k = 2)
Test Items(10 m Anechoic Chamber)	Uncertainty	Remark
Radiated emission (30 MHz ~ 300 MHz, 10 m, Vertical)	4.74 dB	Confidence level of approximately 95 % (k = 2)
Radiated emission (30 MHz ~ 300 MHz, 10 m, Horizontal)	4.71 dB	Confidence level of approximately 95 % (k = 2)
Radiated emission (300 MHz ~ 1 000 MHz, 10 m, Vertical)	4.81 dB	Confidence level of approximately 95 % (k = 2)
Radiated emission (300 MHz ~ 1 000 MHz, 10 m, Horizontal)	4.79 dB	Confidence level of approximately 95 % (k = 2)
Radiated emission (1 000 MHz ~ 6 000 MHz, 3 m)	5.83 dB	Confidence level of approximately 95 % (k = 2)
Radiated emission (1 000 MHz ~ 18 000 MHz, 3 m)	5.77 dB	Confidence level of approximately 95 % (k = 2)

Where relevant, the following measurement uncertainty levels have been estimated for tests performed on the EUT as specified in CISPR 16-4-2.

The listed uncertainties are the worst case uncertainty for the entire range of measurement. please note that the uncertainty values are provided for informational purposes only are not used in determining the PASS/FAIL results





**5.4 Limit**

Frequency (MHz)	FCC Limit @ 3 m. dB $\mu$ V/m	CISPR Limit @ 10 m. dB $\mu$ V/m
30 ~ 88	40.0	30.0
88 ~ 216	43.5	30.0
216 ~ 230	46.0	30.0
230 ~ 960	46.0	37.0
960 ~ 1 000	54.0	37.0

Frequency (MHz)	FCC Class B Peak Limit @ 3 m dB $\mu$ V/m	FCC Class B Average Limit@ 3 m dB $\mu$ V/m
> 1 000	74.0	54.0

Frequency (MHz)	CISPR Class B Peak Limit @ 3 m dB $\mu$ V/m	CISPR Class B Average Limit@ 3 m dB $\mu$ V/m
> 1 000	70.0	50.0





### 5.5 Test Equipment used

Model Name	Manufacturer	Description	Serial Number	Due to Calibration
<input type="checkbox"/> - ESIB26	Rohde & Schwarz	EMI Test Receiver	830482/010	Apr. 16, 2019
<input checked="" type="checkbox"/> - ESR7	Rohde & Schwarz	EMI Test Receiver	101382	Apr. 17, 2019
<input checked="" type="checkbox"/> - VULB9160	Schwarzbeck	Broad Band Test Antenna	3099	Sept. 29, 2019
<input checked="" type="checkbox"/> - BBHA9120D	Schwarzbeck	Horn ANT	597	Apr. 23, 2019
<input type="checkbox"/> - MCU066	mature GmbH	Position Controller	1390306	N/A
<input type="checkbox"/> - TT2.5SI	mature GmbH	Turntable	1390307	N/A
<input type="checkbox"/> - AM 4.0	mature GmbH	Antenna Mast	1390308	N/A
<input checked="" type="checkbox"/> - CO3000	Innco system GmbH	Position Controller	1390306	N/A
<input checked="" type="checkbox"/> - DT3000	Innco system GmbH	Turntable	1390307	N/A
<input checked="" type="checkbox"/> - MA4000-EP	Innco system GmbH	Antenna Mast	1390308	N/A
<input checked="" type="checkbox"/> - AFS 44 00101800-25-10P-44	MITEQ	Preamplifier	1258943	Apr. 18,2019
<input checked="" type="checkbox"/> - TK-PA06S	TESTEK	Preamplifier	170038-L	Apr. 18,2019
<input checked="" type="checkbox"/> - EMI test receiver	Rohde & Schwarz	ESU40	100266	Apr. 17, 2019
<input checked="" type="checkbox"/> - Position Controller	Mature GmbH	MCU066	1390306	N/A
<input checked="" type="checkbox"/> - Turntable	Mature GmbH	TT2.5SI	1390307	N/A
<input checked="" type="checkbox"/> - CO3000	Innco system GmbH	Position Controller	CO3000/1804/4 2760218/P	N/A
<input checked="" type="checkbox"/> - MA4640-XP-ET	Innco system GmbH	Antenna Mast	5580916	N/A
<input checked="" type="checkbox"/> - High Pass Filter	WAINWRIGHT INSTRUMENTS	WHKX3.0/18G-10SS	SN31	Apr. 12, 2019
<input checked="" type="checkbox"/> - EMC 32	Rohde & Schwarz	Software	Ver.9.26.01	N/A

### 5.6 Test data for Radiated Emission

- Test Date : Feb. 26, 2019
- Measurement Distance : 3 m, 10 m
- Note : The highest frequency of the internal source of the EUT is 2 480 MHz.  
The measurement was made up to 12.5 GHz.

#### - Measurement

Frequency range	30 MHz ~ 1 GHz	Above 1 GHz
Detector mode	Quasi peak	Peak / Average
Resolution bandwidth	120 kHz	1 MHz





- 30 MHz ~ 1 GHz

▪ Operating condition: RF Communication mode

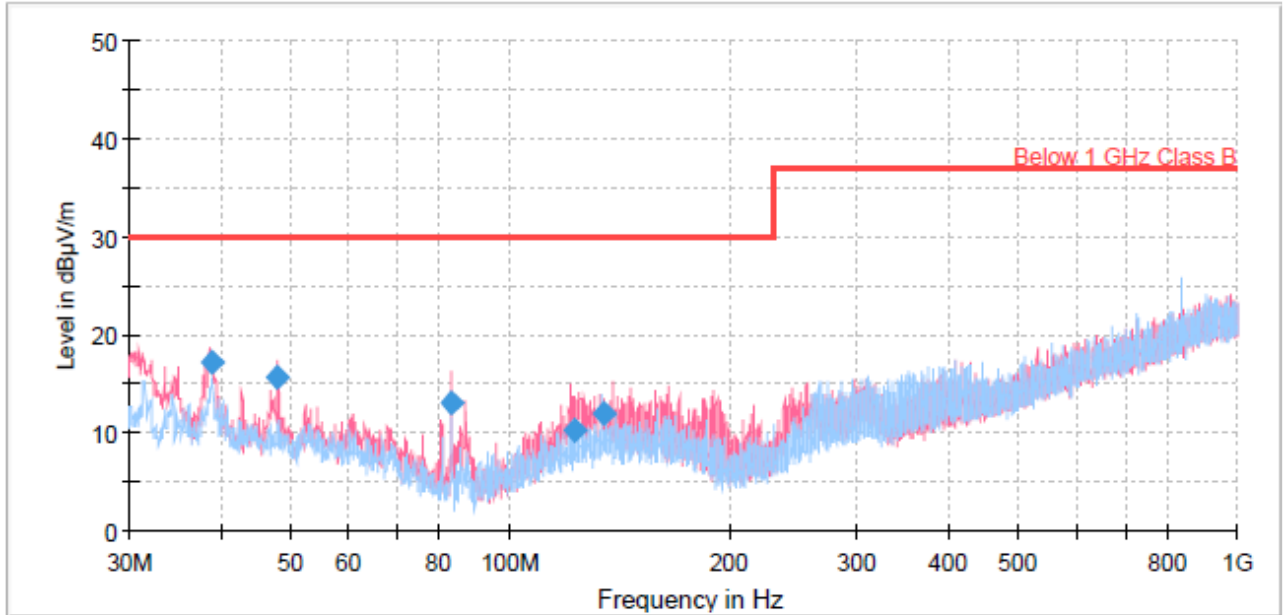

— Preview Result 1V-PK+      — Preview Result 1H-PK+  
 — Below 1 GHz Class B      ◆ Final Result QPK

Frequency (MHz)	QuasiPeak (dBµV/m)	Limit (dBµV/m)	Margin (dB)	Meas. Time (ms)	Bandwidth (kHz)	Height (cm)	Pol	Azimuth (deg)	Corr. (dB/m)
30.505	14.70	30.00	15.30	1000.0	120.000	180.0	V	349.0	-29
38.944	17.12	30.00	12.88	1000.0	120.000	400.0	V	283.0	-29
47.984	15.76	30.00	14.24	1000.0	120.000	105.0	V	18.0	-30
83.070	12.97	30.00	17.03	1000.0	120.000	325.0	V	171.0	-35
122.442	10.24	30.00	19.76	1000.0	120.000	182.0	V	324.0	-31
134.346	11.95	30.00	18.05	1000.0	120.000	216.0	V	31.0	-30

< Fig 5. Radiated emission result (30 MHz ~ 1 000 MHz) >





- 1 GHz ~ 6 GHz

▪ Operating condition: RF Communication mode

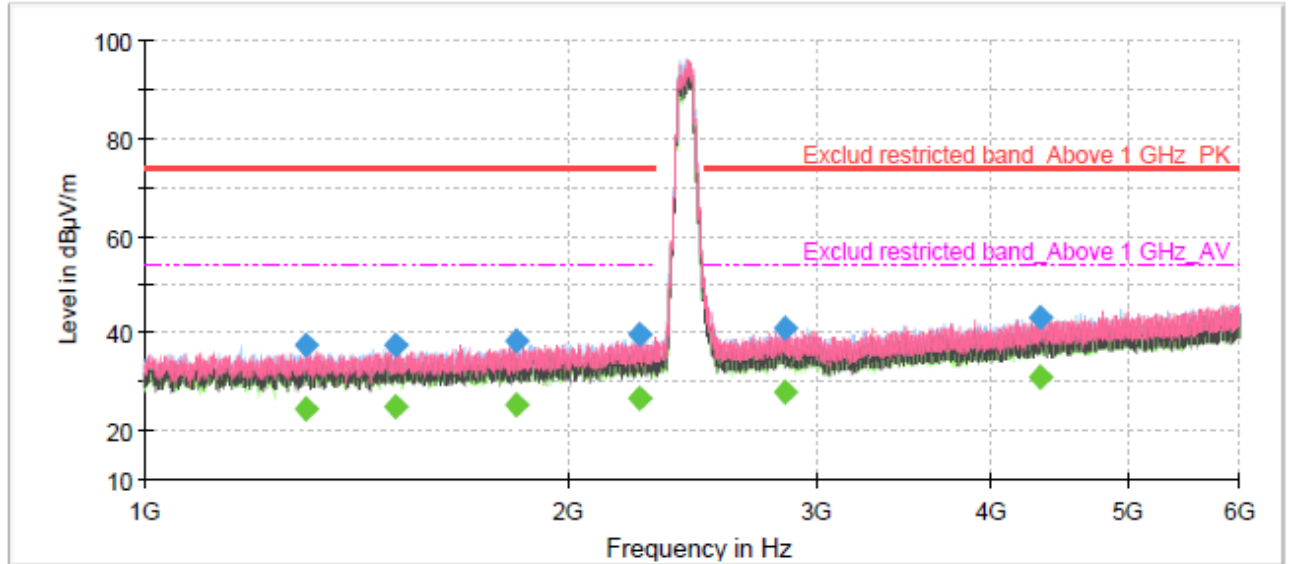

— Preview Result 2H-AVG  
— Preview Result 2V-AVG  
— Exclud restricted band\_Above 1 GHz\_PK  
◆ Final\_Result PK+  
— Preview Result 1H-PK+  
— Preview Result 1V-PK+  
- - - Exclud restricted band\_Above 1 GHz\_AV  
◆ Final\_Result CAV

Frequency (MHz)	MaxPeak (dBµV/m)	CAverage (dBµV/m)	Limit (dBµV/m)	Margin (dB)	Meas. Time (ms)	Bandwidth (kHz)	Height (cm)	Pol	Azimuth (deg)	Corr. (dB/m)
1300.167	---	24.51	54.00	29.49	1000.0	1000.000	200.0	V	143.0	-3
1300.167	37.53	---	74.00	36.47	1000.0	1000.000	200.0	V	143.0	-3
1509.567	37.67	---	74.00	36.33	1000.0	1000.000	196.0	H	326.0	-1
1509.567	---	24.92	54.00	29.08	1000.0	1000.000	196.0	H	326.0	-1
1835.167	38.39	---	74.00	35.61	1000.0	1000.000	180.0	V	172.0	1
1835.167	---	25.47	54.00	28.53	1000.0	1000.000	180.0	V	172.0	1
2245.133	---	26.67	54.00	27.33	1000.0	1000.000	200.0	V	165.0	3
2245.133	39.91	---	74.00	34.09	1000.0	1000.000	200.0	V	165.0	3
2848.767	---	28.10	54.00	25.90	1000.0	1000.000	200.0	V	2.0	6
2848.767	41.14	---	74.00	32.86	1000.0	1000.000	200.0	V	2.0	6
4334.700	---	30.93	54.00	23.07	1000.0	1000.000	125.0	V	197.0	12
4334.700	43.41	---	74.00	30.59	1000.0	1000.000	125.0	V	197.0	12

< Fig 6. Radiated emission result (1 000 MHz ~ 6 000 MHz) >





- 6 GHz ~ 12.5 GHz

▪ Operating condition: RF Communication mode

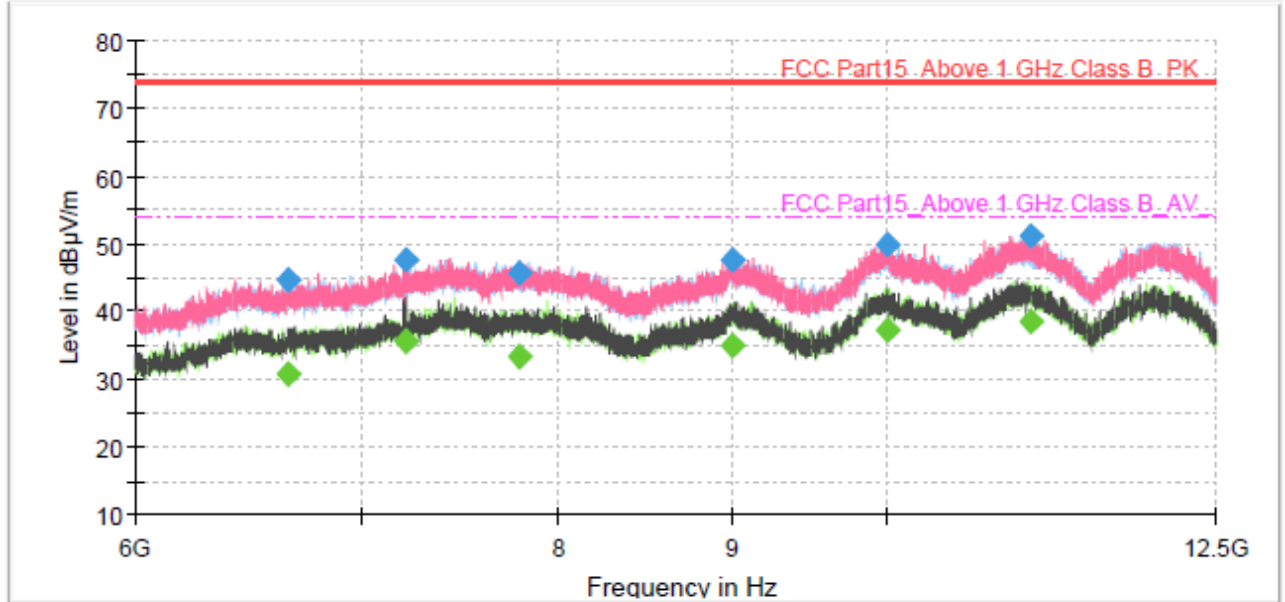

— Preview Result 2H-AVG  
— Preview Result 2V-AVG  
— FCC Part15\_Above 1 GHz Class B\_PK\_  
◆ Final\_Result PK+

— Preview Result 1H-PK+  
— Preview Result 1V-PK+  
- - - FCC Part15\_Above 1 GHz Class B\_AV\_  
◆ Final\_Result CAV

Frequency (MHz)	MaxPeak (dBµV/m)	CAverage (dBµV/m)	Limit (dBµV/m)	Margin (dB)	Meas. Time (ms)	Bandwidth (kHz)	Height (cm)	Pol	Azimuth (deg)	Corr. (dB/m)
6655.650	---	30.64	54.00	23.36	500.0	1000.0	179.0	V	-3.0	3.2
6655.650	44.75	---	74.00	29.25	500.0	1000.0	179.0	V	-3.0	3.2
7206.725	47.60	---	74.00	26.40	500.0	1000.0	215.0	V	274.0	5.6
7206.725	---	35.76	54.00	18.24	500.0	1000.0	215.0	V	274.0	5.6
7793.225	---	33.23	54.00	20.77	500.0	1000.0	125.0	H	101.0	6.9
7793.225	45.81	---	74.00	28.19	500.0	1000.0	125.0	H	101.0	6.9
8994.675	47.66	---	74.00	26.34	500.0	1000.0	225.0	H	1.0	10.7
8994.675	---	35.03	54.00	18.97	500.0	1000.0	225.0	H	1.0	10.7
9998.075	---	37.12	54.00	16.88	500.0	1000.0	125.0	V	312.0	13.5
9998.075	49.96	---	74.00	24.04	500.0	1000.0	125.0	V	312.0	13.5
11014.875	---	38.37	54.00	15.63	500.0	1000.0	125.0	V	-9.0	14.6
11014.875	51.15	---	74.00	22.85	500.0	1000.0	125.0	V	-9.0	14.6





## 6. Sample Calculations

$$\text{dB}\mu\text{V} = 20 \text{ Log}_{10}(\mu\text{V}/\text{m})$$

$$\text{dB}\mu\text{V} = \text{dBm} + 107$$

$$\mu\text{V} = 10^{(\text{dB}\mu\text{V}/20)}$$

### 6.1 Example 1 :

■ 20.3 MHz

<b>Class B Limit</b>	<b>= 250 <math>\mu\text{V}</math> = 48 dB<math>\mu\text{V}</math></b>
<b>Reading</b>	<b>= 39.2 dB<math>\mu\text{V}</math></b>
<b>10<sup>(39.2dB<math>\mu\text{V}/20</math></sup>)</b>	<b>= 91.2 <math>\mu\text{V}</math></b>
<b>Margin</b>	<b>= 48 dB<math>\mu\text{V}</math> - 39.2 dB<math>\mu\text{V}</math></b>
	<b>= 8.8 dB</b>

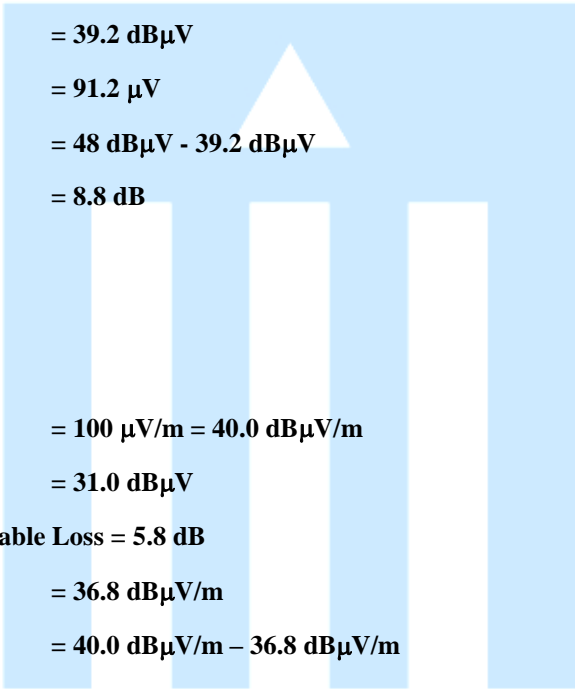

### 6.2 Example 2 :

■ 66.7 MHz

<b>Class B Limit</b>	<b>= 100 <math>\mu\text{V}/\text{m}</math> = 40.0 dB<math>\mu\text{V}/\text{m}</math></b>
<b>Reading</b>	<b>= 31.0 dB<math>\mu\text{V}</math></b>
<b>Antenna Factor + Cable Loss</b>	<b>= 5.8 dB</b>
<b>Total</b>	<b>= 36.8 dB<math>\mu\text{V}/\text{m}</math></b>
<b>Margin</b>	<b>= 40.0 dB<math>\mu\text{V}/\text{m}</math> - 36.8 dB<math>\mu\text{V}/\text{m}</math></b>
	<b>= 3.2 dB</b>





## 7. Recommendation & Conclusion

The data collected shows that the **LG Electronics USA. Premium Magic Remote (Model Name: AN-PM19BA)** was complies with §15.209 of the FCC Rules.

- The end -

