

FCC EVALUATION REPORT FOR CERTIFICATION

Applicant: LG Electronics Inc.

19-1, Cheongho-ri, Jinwi-myeon,

Pyeongteak-si, Gyeonggi-do, Korea.

Attn: Mr. Sung-Wook Yoon / Chief research engineer

Date of Issue: July 17, 2013

Order Number: GETEC-C1-13-185

Test Report Number: GETEC-E3-13-041

Test Site: GUMI COLLEGE EMC CENTER

FCC Registration Number: (100749, 443957)

FCC ID. : BEJPF85UJE

Applicant : LG Electronics Inc.

Rule Part(s) : FCC Part 15 Subpart B
Equipment Class : Class B computing device peripheral (JBP)
EUT Type : DLP PROJECTOR
Type of Authority : Certification
Model Name : PF85U-JE
Trade Name : LG

This equipment has been shown to be in compliance with the applicable technical standards as indicated in the measurement report and was tested in accordance with the measurement procedures specified in ANSI C63.4 (2009) / Canadian standard ICES-003

I attest to the accuracy of data. All measurements reported herein were performed by me or were made under my supervision and are correct to the best of my knowledge and belief. I assume full responsibility for the completeness of these measurements and vouch for the qualifications of all persons taking them.

Tested by,

Reviewed by,

Soon Hoon

**Soon-Hoon Jeong, Associate Engineer
GUMI COLLEGE EMC CENTER**

Jae-Hoon Jeong

**Jae-Hoon Jeong, Technical Manager
GUMI COLLEGE EMC CENTER**





CONTENTS

1. GENERAL INFORMATION	3
2. INTRODUCTION	4
3. PRODUCT INFORMATION	5
3.1 DESCRIPTION OF EUT.....	5
3.2 SUPPORT EQUIPMENT / CABLES USED	6
3.3 MODIFICATION ITEM(S).....	7
4. DESCRIPTION OF TESTS.....	8
4.1 TEST CONDITION.....	8
4.2 CONDUCTED EMISSION	9
4.3 RADIATED EMISSION.....	10
5. CONDUCTED EMISSION.....	11
5.1 OPERATING ENVIRONMENT	11
5.2 TEST SET-UP	11
5.3 MEASUREMENT UNCERTAINTY.....	11
5.4 LIMIT	12
5.5 TEST EQUIPMENT USED.....	12
5.6 TEST DATA FOR CONDUCTED EMISSION	12
6. RADIATED EMISSION	14
6.1 OPERATING ENVIRONMENT	14
6.2 TEST SET-UP	14
6.3 MEASUREMENT UNCERTAINTY.....	14
6.4 LIMIT	15
6.5 TEST EQUIPMENT USED.....	15
6.6 TEST DATA FOR RADIATED EMISSION.....	15
7. SAMPLE CALCULATIONS.....	18
7.1 EXAMPLE 1 :	18
7.2 EXAMPLE 2 :	18
8. RECOMMENDATION & CONCLUSION.....	19
APPENDIX A – ATTESTATION STATEMENT	
APPENDIX B – ID SAMPLE LABEL & LOCATION	
APPENDIX C – BLOCK DIAGRAM	
APPENDIX D – TEST SET-UP PHOTOGRAPHS	
APPENDIX E – EXTERNAL PHOTOGRAPHS	
APPENDIX F – INTERNAL PHOTOGRAPHS	
APPENDIX G – USER’S MANUAL	





Scope: Measurement and determination of electromagnetic emissions (EME) of radio frequency devices including intentional and / or unintentional radiators for compliance with technical rules and regulations of the Federal Communications Commission.

1. General Information

Applicant: LG Electronics Inc.

Applicant Address: 19-1, Cheongho-ri, Jinwi-myeon, Pyeongteak-si, Gyeonggi-do, Korea.

Manufacturer: LG Electronics Inc.

Manufacturer Address: 19-1, Cheongho-ri, Jinwi-myeon, Pyeongteak-si, Gyeonggi-do, Korea.

Contact Person: Mr. Sung-Wook Yoon, Chief research engineer

Tel Number: +82-31-610-9623

● FCC ID.	BEJPF85UJE
● EUT Type	DLP PROJECTOR
● Model Name	PF85U-JE
● Trade Name	LG
● Serial Number	Prototype
● Rule Part(s)	FCC Part 15 Subpart B
● Type of Authority	Certification
● Test Procedure(s)	ANSI C63.4 (2009) / Canadian standard ICES-003
● Dates of Test	June 17 ~ 18, 2013
● Place of Test	GUMI COLLEGE EMC CENTER (FCC Registration Number: 100749, 443957) 37 Yaeun-ro, Gumi-si, Gyeongsangbuk-do, 730-711, Republic of Korea.
● Test Report Number	GETEC-E3-13-041
● Date of Issue	July 17, 2013

EUT Type: DLP PROJECTOR

FCC ID.: BEJPF85UJE





2. Introduction

The measurement procedure described in American National Standard for Methods of Measurement of Radio-Nose Emissions From Low-Voltage Electrical and Electronic Equipment in the Range of 9 kHz to 40 GHz (ANSI C63.4-2009) was used in determining radiated and conducted emissions emanating from **LG Electronics Inc.**

DLP PROJECTOR (Model Name: PF85U-JE)

These measurement tests were conducted at **GUMI COLLEGE EMC CENTER**

The site address is 37 Yaeun-ro, Gumi-si, Gyeongsangbuk-do, 730-711, Republic of Korea.

This test site is one of the highest point of Gumi college at about 200 km away from Seoul city and 40 km away from Daegu city. It is located in the valley surrounded by mountains in all directions where ambient radio signal conditions are quiet and a favorable area to measure the radio frequency interference on open field test site for the computing and ISM devices manufactures. The detailed description of the measurement facility was found to be in compliance with the requirements of §2.948 according to ANSI C63.4 (2009)

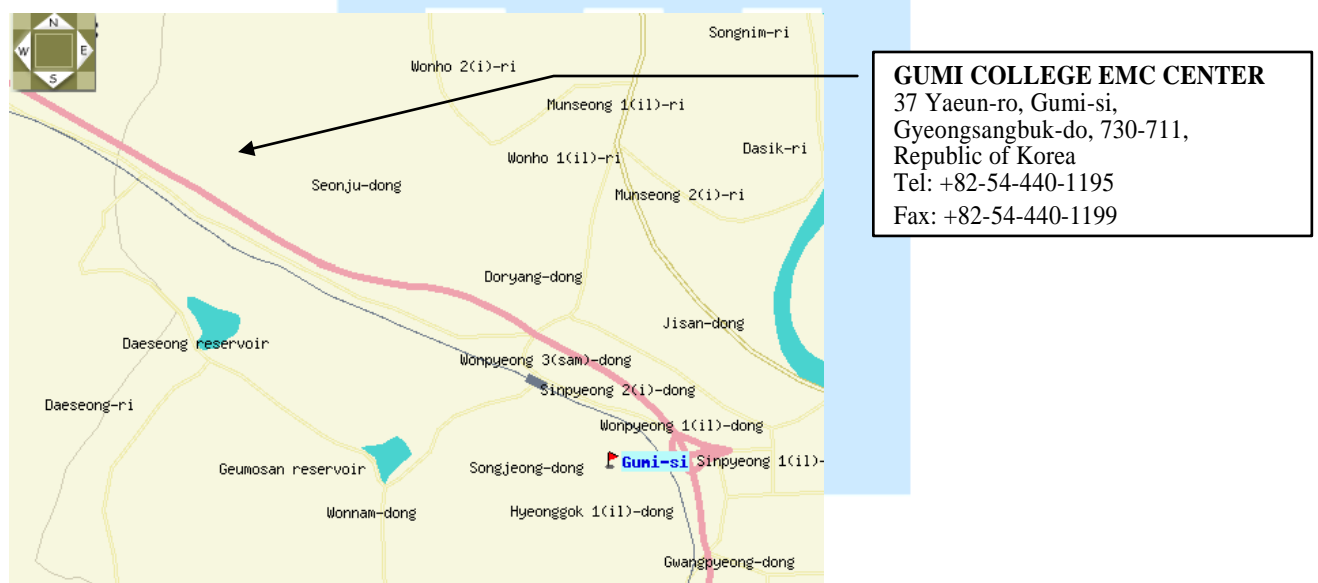

Fig 1. The map above shows the Gumi College in vicinity area.





3. Product Information

3.1 Description of EUT

The Equipment under Test (EUT) is the **LG Electronics Inc.**
DLP PROJECTOR (Model Name: PF85U-JE) FCC ID.: BEJPF85UJE

Model	PF85U(PF85U-JE)	
Resolution (Pixel)	1920 (Horizontal) × 1080 (Vertical)	
Aspect ratio	16:9 (Horizontal:Vertical)	
Panel size (mm)	16.654	
Projection distance (Video size)	0.63 m - 3.72 m (50.8 cm - 304.8 cm)	
Ratio of upward projection	100 %	
Working range of the remote control	6 m	
POWER	AC 100 ~ 240 V, 50 Hz/ 60 Hz	
Audio output	5 W + 5 W	
Reception type	NTSC, ATSC	
Reception channels	VHF : 02 - 13, UHF 14 - 69, CATV 01 - 135, DTV 02 - 69, CADTV 01 - 135	
External Antenna Impedance	75 Ω	
Height (mm)	Min. 45.9(without foot), Max. 55.3(without foot), 56.9(with foot)	
Width (mm)	275.0	
Depth (mm)	212.7(without lens), 226.0(with lens)	
Weight (g)	2200	
USB Device	5 V, 0.5 A (Max.)	
Operation environment	Temperature	
	Operation	0 °C to 40 °C
	Storage	-20 °C to 60 °C
	Relative humidity	
	Operation	0 % - 80 %
Storage	0 % - 85 %	

- Highest clock Frequency : 800 MHz

Wireless LAN module(WN8122E1) specification

Standard	IEEE802.11a/b/g/n
Frequency Range	2400 to 2483.5 MHz 5150 to 5250 MHz 5725 to 5850 MHz
Output Power (Max.)	802.11a: 16.5 dBm 802.11b: 16 dBm 802.11g: 15.5 dBm 802.11n - 2.4GHz: 15.5 dBm 802.11n - 5GHz: 16.5 dBm

Bluetooth module (BM-LDS401) specification

Standard	Bluetooth Version 3.0
Frequency Range	2400 ~ 2483.5 MHz
Output Power (Max.)	10 dBm or lower

- Contains FCC ID: BEJLDS401 / Contains IC: 2703H-LDS401

EUT Type: DLP PROJECTOR

FCC ID.: BEJPF85UJE





3.2 Support Equipment / Cables used

3.2.1 Used Support Equipment

Description	Manufacturer	Model Name	S/N & FCC ID.
PC(Main board)	ASUSTEK COMPUTER INC.	P8H61	S/N: 0BG084-02014-MIBFE0-A05 FCC ID.: DoC
Graphic card	Absolute korea	HIS6770	S/N: H110838565 FCC ID.: DoC
PS2 keyboard	COMPAQ	166516-AD6	S/N: B13BBOR391006D FCC ID.: AQ6-23K15
USB mouse	Microsoft Corporation	1484	S/N: 0352700289761 FCC ID: DoC
DVD player	ILIKE ELECTRONICS CO., LTD.	CVX-3800 Full-HD	S/N: CVX380020110110493 FCC ID.: Verification
USB memory stick	SAMSUNG	SUM-PSB4	S/N: TBBB202478F FCC ID.: DoC
Cellphone	LG Electronics	LG-LU6200	S/N: 201KPNY0507743 FCC ID.: None.
TV Signal generator	Rohde & schwarz	SFQ	S/N: 100563 FCC ID.: Verification

See "Appendix D – Test Setup Photographs" for actual system test set-up

3.2.2 System configuration

Description	Manufacturer	Model Name	S/N & FCC ID.
IR Remote controller	LG Electronics Inc.	AKB73616415	S/N; None. FCC ID.: None.
Motion Remote controller	LG Electronics Inc.	AKB73856202	S/N: None. FCC ID.: None.
Wi-Fi module	LG Electronics Inc.	WN8122E1	S/N; None. FCC ID.: BEJWN8122E1
Bluetooth module	LG Electronics Inc.	BM-LDS401	S/N; None. FCC ID.: BEJLDS401

- External components: IR Remote controller, Motion Remote controller
- Built-in components: Wi-Fi module, Bluetooth module

EUT Type: DLP PROJECTOR

FCC ID.: BEJPF85UJE





3.2.3 Used Cable(s)

Cable Name	Condition	Description
Power in	Connected to the EUT and Power supply	1.80 m unshielded
HDMI in	Connected to the EUT and PC	1.80 m shielded
Component	Connected to the EUT and DVD Player	3.00 m shielded
VIDEO in	Connected to the EUT and DVD Player	3.00 m shielded
HDMI(MHL) in	Connected to the EUT and Cellphone	1.00 m shielded with a ferrite core
Headphone out	Connected to the EUT and Headphone	1.20 m shielded
LAN	Connected to the EUT and Network	10.00 m unshielded
Antenna cable	Connected to the EUT and TV Signal generator	10.00 m shielded with two ferrite cores

3.3 Modification Item(s)

- None





4. Description of tests

4.1 Test Condition

The EUT was installed, arranged and operated in a manner that is most representative of equipment as typically used. The measurements were carried out while varying operating modes and cable positions within typically arrangement to determine maximum emission level.

The representative and worst test mode(s) were noted in the test report.

The test conditions of the noted test mode(s) in this test report are;

- Test Voltage / Frequency : AC 120 V / 60 Hz
- Test Mode(s)
 - **projector mode**
 - . 1 920 × 1 080 / 60 Hz (HDMI: Digital)
 - **Operating test pattern**
 - . “H” character scrolling mode (Font size: 10)
 - . Black background white character
 - . Brightness and contrast was adjusted as maximum level
 - . USB memory stick was connected to the USB port

“The verification report for TV/AV mode would be issued by LG Electronics Inc.”





4.2 Conducted Emission

The Line conducted emission test facility is inside a 4 m × 8 m × 2.5 m shielded enclosure. (FCC Registration No.: 100749)

The EUT was placed on a non-conducting 1.0 m by 1.5 m table, which is 0.8 m in height and 0.4 m away from the vertical wall of the shielded enclosure.

The EUT is powered from the Rohde & Schwarz LISN (ESH2-Z5) and the support equipment is powered from the Rohde & Schwarz LISN (ESH3-Z5). Powers to the LISN are filtered by high-current high insertion loss power line filter.

Sufficient time for EUT, support equipment, and test equipment was allowed in order for them to warm up to their normal operating condition.

The RF output of the LISN was connected to the EMI test receiver (Rohde & Schwarz, ESCS30).

Exploratory measurements were conducted to identify the highest emission by operating the EUT in a range of typical modes of operation, cable positions, system configuration and arrangement.

Based on exploratory measurements, the final measurements were conducted at the worst test conditions.

Exploratory measurements were scanned using Peak mode of EMI Test receiver from 150 kHz to 30 MHz with 20 ms sweep time. The final measurements were measured with Quasi-Peak and Average mode.

The bandwidth of EMI Test Receiver was set to 9 kHz. Interface cables were connected to the available interface ports of the test unit. Excess cable lengths were bundled at center with 30 cm ~ 40 cm.

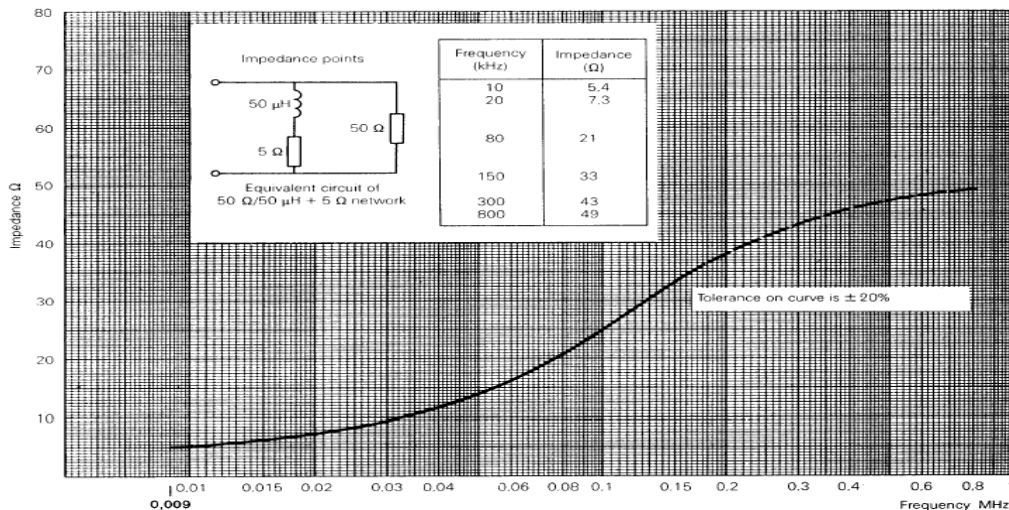

Fig 2. Impedance of LISN





4.3 Radiated Emission

Exploratory Radiated measurements were conducted at the 3 m semi anechoic chamber in order to identify the highest emission by operating the EUT in a range of typical modes of operation, cable positions, system configuration and arrangement.

Based on exploratory measurements, the final measurements were conducted at the worst test conditions.

Final measurements of below 1GHz were made at 3 m Chamber (FCC Registration No.: 443957) or Open area test site (FCC Registration No.: 100749) that complies with CISPR 16/ANSI C63.4.

Above 1 GHz final measurements were conducted at the 3m Chamber (FCC Registration No.: 443957) only.

For measurements above 1GHz, the bottom side of 3 m chamber was installed with absorbers in order to meet SVSWR Limit.

Exploratory measurements were scanned using Peak mode of EMI Test receiver and final measurements were measured with Quasi-Peak mode (Below 1 GHz) and Peak & Average mode (Above 1 GHz).

The measurements were performed by rotating the EUT 360° and adjusting the receive antenna height from 1.0 m to 4.0 m. All frequencies were investigated in both horizontal and vertical antenna polarity.

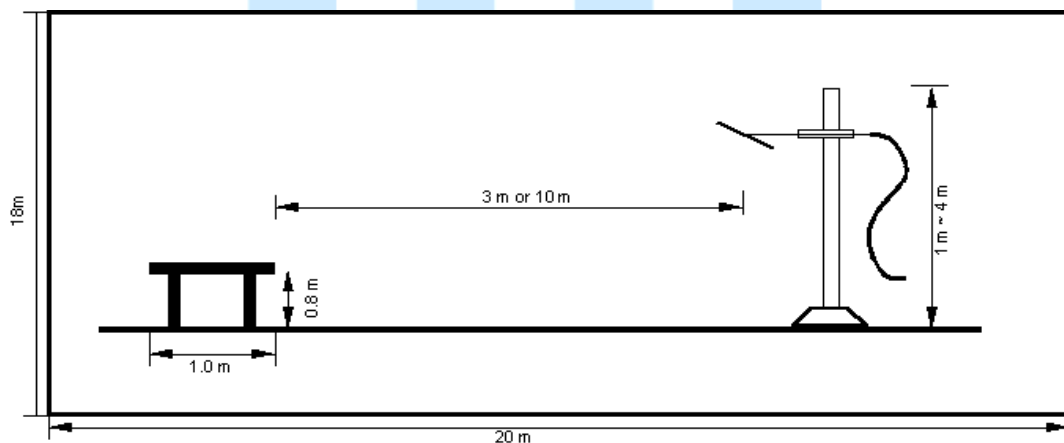

Fig 3. Dimensions of test site (Below 1 GHz)

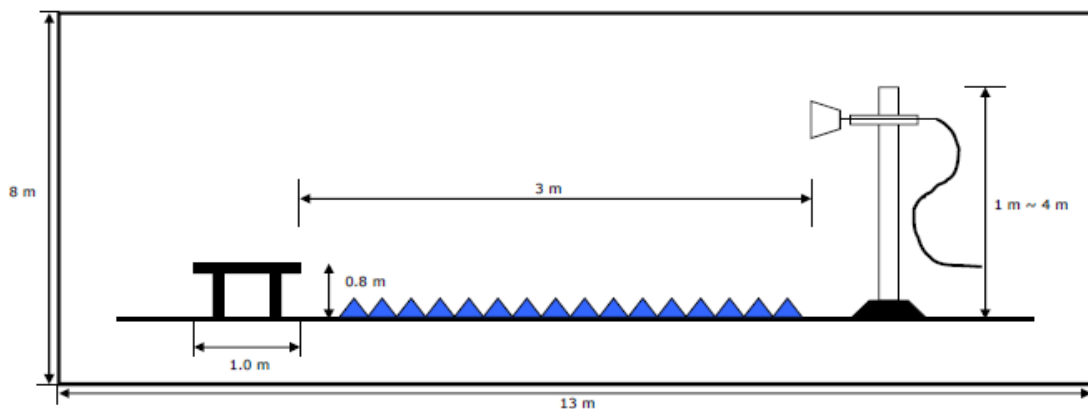

Fig 4. Dimensions of test site (Above 1 GHz)





5. Conducted Emission

5.1 Operating Environment

Temperature : 23.0 °C
 Relative Humidity : 54.0 % R.H.

5.2 Test Set-up

The conducted emission measurements were performed in the shielded room.

The EUT was placed on wooden table, 0.8 m heights above the floor, 0.4 m from the reference ground plane (GRP) wall and 0.8 m from AMN & ISN.

AMN is bonded on horizontal reference ground plane.

The ground plane, which was electrically bonded to the shield room, ground system and all power lines entering the shield room, were filtered.

5.3 Measurement Uncertainty

The measurement uncertainty was calculated in accordance with ISO “Guide to the expression of uncertainty in measurement.”

The measurement uncertainty was given with a confidence of 95 %.

Test Items	Uncertainty	Remark
Conducted emission (9 kHz ~ 150 kHz)	± 2.74 dB	Confidence level of approximately 95 % ($k = 2$)
Conducted emission (150 kHz ~ 30 MHz)	± 4.25 dB	Confidence level of approximately 95 % ($k = 2$)





5.4 Limit

RFI Conducted	FCC Limit(dB μ V/m) Class B	
	Quasi-Peak	Average
150 kHz ~ 0.5 MHz	66 ~ 56*	56 ~ 46*
0.5 MHz ~ 5 MHz	56	46
5 MHz ~ 30 MHz	60	50

*Limits decreases linearly with the logarithm of frequency.

5.5 Test Equipment used

Model Name	Manufacturer	Description	Serial Number	Due to Calibration
■ - ESCS30	Rohde & Schwarz	EMI Test Receiver	839809/003	05. 03. 2014
■ - ESH3-Z5	Rohde & Schwarz	LISN	838979/020	05. 03. 2014
■ - ESH2-Z5	Rohde & Schwarz	LISN	829991/009	05. 03. 2014
□ - ISN T8	TESEQ. GmbH	ISN	24568	07. 04. 2013

5.6 Test data for Conducted Emission

- Test Date : June 18, 2013
- Resolution Bandwidth : 9 kHz
- Frequency Range : 0.15 MHz ~ 30 MHz
- Line : L1: Live, N: Neutral





- Operating condition: 1 920 × 1 080 / 60 Hz (HDMI: Digital)

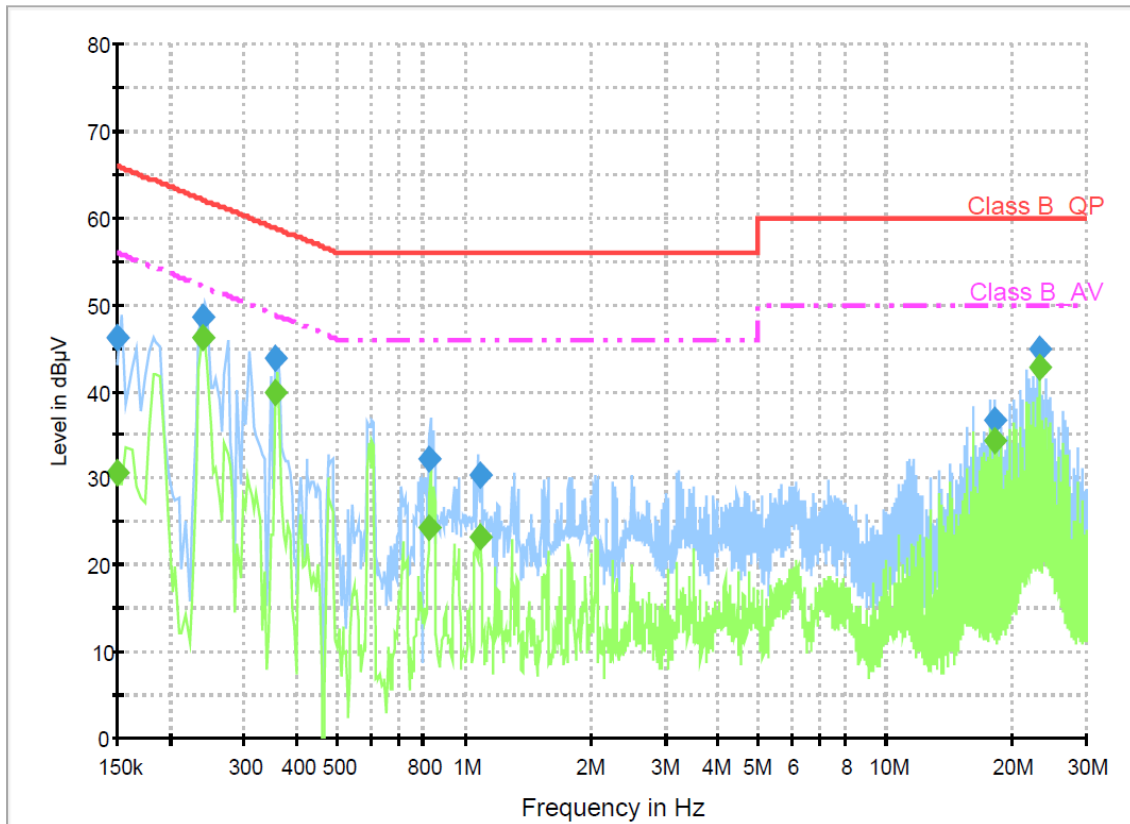

Final Result 1

Frequency (MHz)	QuasiPeak (dBµV)	Meas. Time (ms)	Bandwidth (kHz)	PE	Line	Corr. (dB)	Margin (dB)	Limit (dBµV)	Comment
0.150000	46.3	1000.0	0.200	GND	L1	10.1	19.7	66.0	
0.240000	48.5	1000.0	9.000	GND	N	10.1	13.6	62.1	
0.356000	43.8	1000.0	9.000	GND	N	10.1	15.0	58.8	
0.828000	32.2	1000.0	9.000	GND	L1	10.1	23.8	56.0	
1.092000	30.4	1000.0	9.000	GND	L1	10.1	25.6	56.0	
18.244000	36.6	1000.0	9.000	GND	N	10.4	23.4	60.0	
23.128000	44.9	1000.0	9.000	GND	L1	10.5	15.1	60.0	

Final Result 2

Frequency (MHz)	CAverage (dBµV)	Meas. Time (ms)	Bandwidth (kHz)	PE	Line	Corr. (dB)	Margin (dB)	Limit (dBµV)	Comment
0.150000	30.6	1000.0	9.000	GND	L1	10.1	25.4	56.0	
0.240000	46.2	1000.0	9.000	GND	N	10.1	5.9	52.1	
0.356000	39.8	1000.0	9.000	GND	N	10.1	9.1	48.8	
0.828000	24.4	1000.0	9.000	GND	L1	10.1	21.6	46.0	
1.092000	23.2	1000.0	9.000	GND	L1	10.1	22.8	46.0	
18.244000	34.4	1000.0	9.000	GND	N	10.4	15.6	50.0	
23.128000	42.9	1000.0	9.000	GND	L1	10.5	7.1	50.0	

< Fig 5. Conducted emission result >





6. Radiated Emission

6.1 Operating Environment

Temperature : 24.0 °C
 Relative Humidity : 50.0 % R.H.

6.2 Test Set-up

A preliminary and final measurement was at 3 m anechoic chamber.

The EUT was placed on a non-conductive turntable approximately 0.8 m above the ground plane.

The turntable with EUT was rotated 360°, and the antenna was varied in height between 1.0 m and 4.0 m in order to determine the maximum emission levels.

This procedure was performed for both horizontal and vertical polarization of the receiving antenna.

6.3 Measurement Uncertainty

The measurement uncertainty was calculated in accordance with ISO “Guide to the expression of uncertainty in measurement”.

The measurement uncertainty was given with a confidence of 95 %.

Test Items(Anechoic Chamber)	Uncertainty	Remark
Radiated emission (30 MHz ~ 300 MHz, 3 m, Vertical)	± 4.66 dB	Confidence level of approximately 95 % ($k = 2$)
Radiated emission (30 MHz ~ 300 MHz, 3 m, Horizontal)	± 4.44 dB	Confidence level of approximately 95 % ($k = 2$)
Radiated emission (300 MHz ~ 1 000 MHz, 3 m, Vertical)	± 4.73 dB	Confidence level of approximately 95 % ($k = 2$)
Radiated emission (300 MHz ~ 1 000 MHz, 3 m, Horizontal)	± 4.77 dB	Confidence level of approximately 95 % ($k = 2$)
Radiated emission (1 000 MHz ~ 6 000 MHz, 3 m)	± 4.89 dB	Confidence level of approximately 95 % ($k = 2$)





6.4 Limit

Frequency (MHz)	FCC Limit @ 3 m. dBµV/m	CISPR Limit @ 10 m. dBµV/m
30 ~ 88	40.0	30.0
88 ~ 216	43.5	30.0
216 ~ 230	46.0	30.0
230 ~ 960	46.0	37.0
960 ~ 1 000	54.0	37.0
> 1 000	54.0	No Specified limit

6.5 Test Equipment used

Model Name	Manufacturer	Description	Serial Number	Due to Calibration
■ - ESIB26	Rohde & Schwarz	EMI Test Receiver	830482/010	05. 02. 2014
■ - VULB9160	Schwarzbeck	Broadband Test Antenna	3193	03. 15. 2014
■ - BBHA9120D	Schwarzbeck	Horn Antenna	597	02. 28. 2015
■ - MCU066	maturo GmbH	Position Controller	1390306	N/A
■ - TT2.5SI	maturo GmbH	Turntable	1390307	N/A
■ - AM 4.0	maturo GmbH	Antenna Mast	1390308	N/A
■ - AFS 44 00101800-25-10P-44	MITEQ	Preamplifier	1258943	1. 24. 2014

6.6 Test data for Radiated Emission

- Test Date : June 18, 2013
- Measurement Distance : 3 m
- Note : The highest frequency of the internal source of the EUT is between 500 MHz and 1 000 MHz (800 MHz). The measurement was made up to 5 000 MHz

- Measurement

Frequency range	30 MHz ~ 1 GHz	Above 1 GHz
Detector mode	Quasi peak	Peak / Average
Resolution bandwidth	120 kHz	1 MHz

EUT Type: DLP PROJECTOR

FCC ID.: BEJPF85UJE





- Operating condition: 1 920 × 1 080 / 60 Hz (HDMI: Digital)

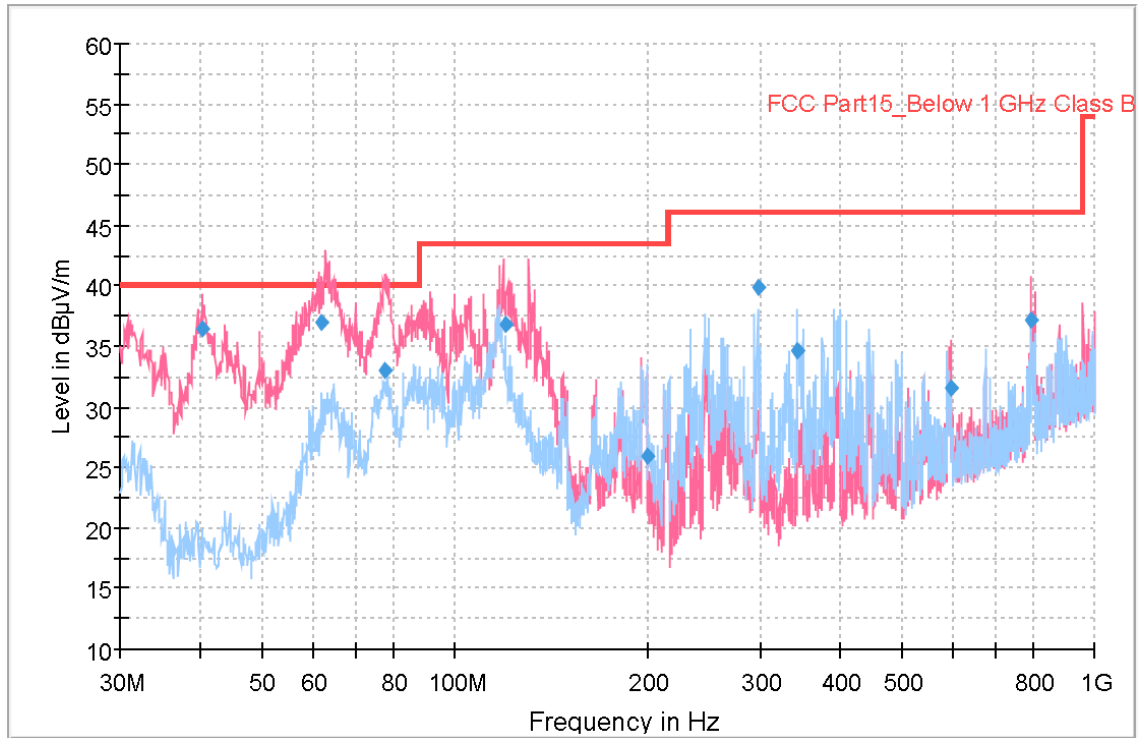

Final Result 1

Frequency (MHz)	QuasiPeak (dBµV/m)	Meas. Time (ms)	Bandwidth (kHz)	Height (cm)	Polarization	Azimuth (deg)	Corr. (dB)	Margin (dB)	Limit (dBµV/m)
40.346250	36.4	1000.0	120.000	100.0	V	132.0	12.6	3.6	40.0
62.020000	37.0	1000.0	120.000	100.0	V	119.0	12.4	3.0	40.0
77.892500	33.0	1000.0	120.000	150.0	V	233.0	9.3	7.0	40.0
119.996250	36.9	1000.0	120.000	100.0	V	84.0	12.4	6.6	43.5
199.473750	26.0	1000.0	120.000	100.0	V	35.0	10.7	17.5	43.5
296.992500	39.8	1000.0	120.000	110.0	H	233.0	14.8	6.2	46.0
343.710000	34.7	1000.0	120.000	100.0	H	78.0	16.1	11.3	46.0
597.368750	31.6	1000.0	120.000	100.0	V	230.0	22.5	14.4	46.0
792.871250	37.1	1000.0	120.000	100.0	V	306.0	25.8	8.9	46.0

< Fig 6. Radiated emission result (30 MHz ~ 1 000 MHz) >





- Operating condition: 1 920 × 1 080 / 60 Hz (HDMI: Digital)
- Green marker: Average detector, Blue marker: Peak detector

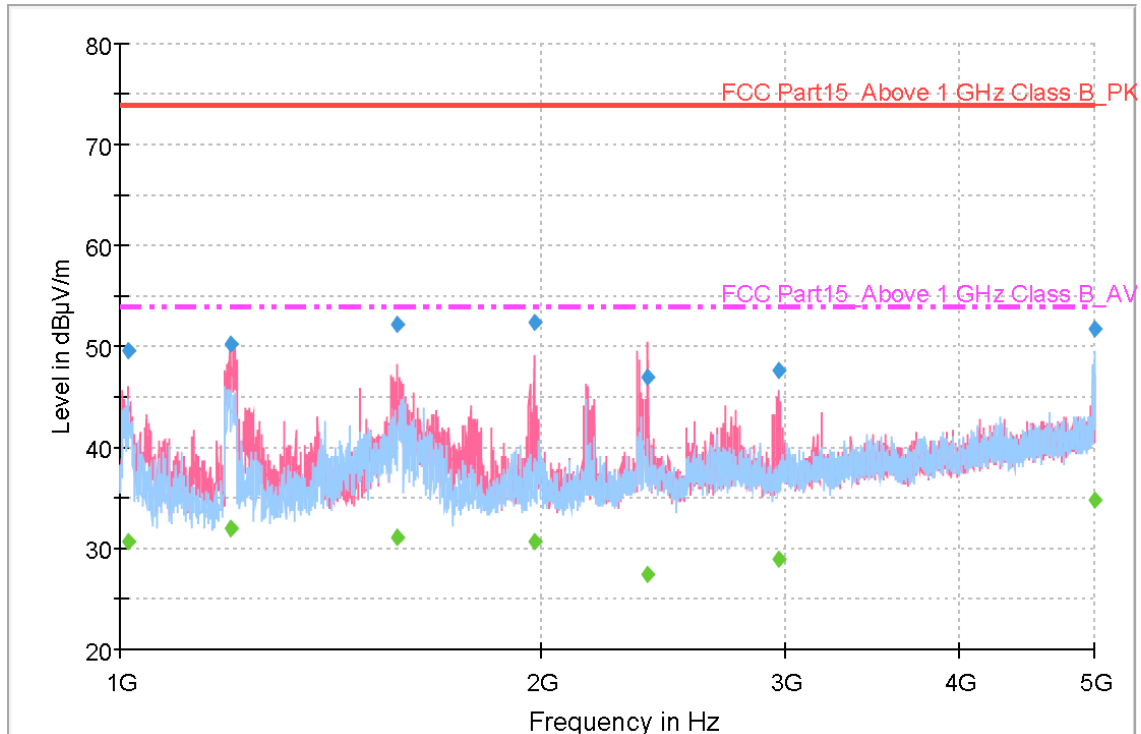

Final Result 1

Frequency (MHz)	MaxPeak (dBµV/m)	Meas. Time (ms)	Bandwidth (kHz)	Height (cm)	Polarization	Azimuth (deg)	Corr. (dB)	Margin (dB)	Limit (dBµV/m)
1014.420000	49.5	1000.0	1000.000	200.0	V	63.0	-11.3	24.5	74.0
1199.160000	50.2	1000.0	1000.000	200.0	V	212.0	-10.0	23.8	74.0
1578.000000	52.2	1000.0	1000.000	110.0	V	133.0	-8.3	21.8	74.0
1981.380000	52.4	1000.0	1000.000	121.0	V	140.0	-7.6	21.6	74.0
2388.100000	46.9	1000.0	1000.000	109.0	V	22.0	-5.6	27.1	74.0
2968.100000	47.6	1000.0	1000.000	100.0	V	225.0	-4.3	26.4	74.0
4992.100000	51.7	1000.0	1000.000	100.0	H	220.0	1.0	22.3	74.0

Final Result 2

Frequency (MHz)	CAverage (dBµV/m)	Meas. Time (ms)	Bandwidth (kHz)	Height (cm)	Polarization	Azimuth (deg)	Corr. (dB)	Margin (dB)	Limit (dBµV/m)
1014.420000	30.6	1000.0	1000.000	200.0	V	63.0	-11.3	23.4	54.0
1199.160000	31.9	1000.0	1000.000	200.0	V	212.0	-10.0	22.1	54.0
1578.000000	31.1	1000.0	1000.000	110.0	V	133.0	-8.3	22.9	54.0
1981.380000	30.7	1000.0	1000.000	121.0	V	140.0	-7.6	23.3	54.0
2388.100000	27.4	1000.0	1000.000	109.0	V	22.0	-5.6	26.6	54.0
2968.100000	28.9	1000.0	1000.000	100.0	V	225.0	-4.3	25.1	54.0
4992.100000	34.8	1000.0	1000.000	100.0	H	220.0	1.0	19.2	54.0

< Fig 7. Radiated emission result (1 000 MHz ~ 5 000 MHz) >





7. Sample Calculations

$$\text{dB}\mu\text{V} = 20 \text{ Log}_{10}(\mu\text{V}/\text{m})$$

$$\text{dB}\mu\text{V} = \text{dBm} + 107$$

$$\mu\text{V} = 10^{(\text{dB}\mu\text{V}/20)}$$

7.1 Example 1 :

■ 20.3 MHz

Class B Limit	= 250 μV = 48 dBμV
Reading	= 39.2 dBμV
$10^{(39.2\text{dB}\mu\text{V}/20)}$	= 91.2 μV
Margin	= 48 dBμV - 39.2 dBμV
	= 8.8 dB

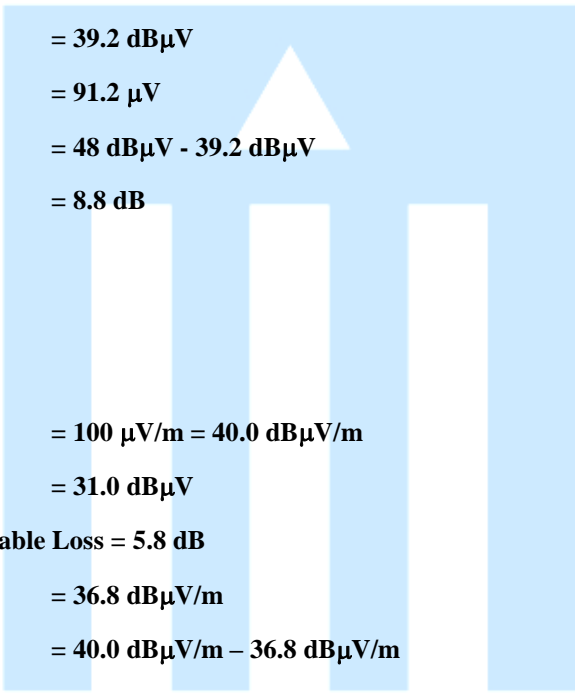

7.2 Example 2 :

■ 66.7 MHz

Class B Limit	= 100 $\mu\text{V}/\text{m}$ = 40.0 dB$\mu\text{V}/\text{m}$
Reading	= 31.0 dBμV
Antenna Factor + Cable Loss	= 5.8 dB
Total	= 36.8 dB$\mu\text{V}/\text{m}$
Margin	= 40.0 dB$\mu\text{V}/\text{m}$ - 36.8 dB$\mu\text{V}/\text{m}$
	= 3.2 dB





8. Recommendation & Conclusion

The data collected shows that the **LG Electronics Inc. DLP PROJECTOR (Model Name: PF85U-JE)** was complies with §15.107 and 15.109 of the FCC Rules.

- The end -

