



reference guide

hp iPAQ Pocket PC h5400 series

Document Part Number: 281984-001

July 2002

© 2002 Hewlett-Packard Company

Microsoft, MS-DOS, Windows, Windows NT are trademarks of Microsoft Corporation in the U.S. and other countries.

Intel, Pentium, Intel Inside, and Celeron are trademarks of Intel Corporation in the U.S. and other countries.

Adobe, Acrobat, and Acrobat Reader are trademarks or registered trademarks of Adobe Systems Incorporated.

All other product names mentioned herein may be trademarks of their respective companies.

Hewlett-Packard Company shall not be liable for technical or editorial errors or omissions contained herein or for incidental or consequential damages in connection with the furnishing, performance, or use of this material. The information in this document is provided "as is" without warranty of any kind, including, but not limited to, the implied warranties of merchantability and fitness for a particular purpose, and is subject to change without notice. The warranties for HP products are set forth in the express limited warranty statements accompanying such products. Nothing herein should be construed as constituting an additional warranty.

This document contains proprietary information that is protected by copyright. No part of this document may be photocopied, reproduced, or translated to another language without the prior written consent of Hewlett-Packard Company.



WARNING: Text set off in this manner indicates that failure to follow directions could result in bodily harm or loss of life.



CAUTION: Text set off in this manner indicates that failure to follow directions could result in damage to equipment or loss of information.

reference guide

hp iPAQ Pocket PC h5400 series

First Edition July 2002

Document Part Number: 281984-001

Contents

1 Getting Started

| | |
|---|------|
| What is in the Box? | 1-2 |
| Front Panel | 1-4 |
| Top Panel | 1-6 |
| Bottom Panel | 1-7 |
| Back Panel | 1-8 |
| Universal Cradle | 1-9 |
| Register the hp iPAQ Pocket PC | 1-10 |
| Set Up Your hp iPAQ Pocket PC | 1-10 |
| Establish a Partnership | 1-12 |
| For More Product Information | 1-15 |
| Troubleshooting and Support Information | 1-17 |

2 Getting Acquainted

| | |
|---|------|
| Enter Information | 2-1 |
| Change Word Suggestion Options | 2-2 |
| Type with the On-Screen Keyboard | 2-4 |
| Write with the Stylus and the Letter Recognizer | 2-6 |
| Write with the Stylus and the Transcriber | 2-8 |
| Write with the Stylus and Block Recognizer | 2-8 |
| Draw and Write on the Screen | 2-9 |
| Convert Writing to Text | 2-10 |
| Customize Settings | 2-11 |
| Set the Time for Home | 2-11 |

| | |
|--|------|
| Set the Time for a Location You Are Visiting | 2-13 |
| Set the Date | 2-14 |
| Change the Backlight Settings. | 2-15 |
| Manage Your iPAQ Pocket PC | 2-16 |
| Back Up Information. | 2-17 |
| Use the iPAQ File Store | 2-28 |
| Perform a Full Reset | 2-29 |
| Perform a Normal Reset | 2-30 |
| Align the Screen | 2-31 |
| Use the Self-Test | 2-31 |
| Manage the Battery | 2-32 |
| Install the Battery. | 2-32 |
| Automatically Monitor the Battery | 2-33 |
| Manually Monitor the Battery | 2-35 |
| Charge the Battery | 2-35 |
| Adjust the Standby Setting | 2-38 |
| Change the Battery Pack | 2-39 |
| Reactivate the Battery | 2-39 |
| Work with Applications | 2-40 |
| Open Applications | 2-40 |
| Minimize Applications | 2-41 |
| Close Applications. | 2-41 |
| Install Applications | 2-43 |
| Customize the Application Buttons. | 2-43 |
| View Images | 2-45 |

3 Using the Wireless LAN

| | |
|--|-----|
| Learn the Terms | 3-1 |
| Get Acquainted. | 3-2 |
| Turn ON the WLAN | 3-3 |
| Work with Profiles | 3-4 |
| Create Profiles without Security | 3-4 |
| Create Profiles with Security | 3-7 |
| Close the WLAN Application | 3-8 |
| View Existing Profiles. | 3-8 |

| | |
|--|------|
| Select an Existing Profile | 3-8 |
| Edit an Existing Profile | 3-9 |
| Delete a Profile | 3-9 |
| Monitor Signal Strength and Status | 3-10 |
| View Radio Signal Strength | 3-10 |
| View WLAN Status. | 3-10 |
| Locate and Link to Wireless Sites | 3-11 |
| Search for Wireless Sites. | 3-11 |
| Link to a Wireless Site. | 3-11 |
| Recommended Uses. | 3-12 |

4 Using Bluetooth

| | |
|--|------|
| Get Acquainted with Bluetooth | 4-2 |
| Understand Terms | 4-3 |
| Review Supported Services. | 4-4 |
| Work with Bluetooth Settings | 4-5 |
| Work with the Bluetooth Manager | 4-7 |
| Locate and Select a Device | 4-8 |
| Understand Profiles | 4-8 |
| Create a Profile | 4-8 |
| Activate a Profile. | 4-9 |
| Rename a Profile | 4-10 |
| Delete a Profile | 4-10 |
| Save Configuration Settings in a Profile | 4-10 |
| Set Accessibility Properties | 4-11 |
| Enter a Device Name. | 4-11 |
| Allow Others to Locate My Device. | 4-12 |
| Pair Devices. | 4-12 |
| Unpair Devices | 4-14 |
| Allow Connecting | 4-14 |
| Enable Bluetooth Services. | 4-15 |
| Set Shared Folder. | 4-18 |
| Select Business Card Information | 4-19 |

| | |
|--|------|
| Connect to Other Devices | 4-20 |
| Identify the Communications Port. | 4-20 |
| Establish a Serial Connection | 4-20 |
| Use Dial-Up Networking. | 4-21 |
| Work with Files | 4-23 |
| Create a File Transfer Connection. | 4-23 |
| Send Files | 4-23 |
| Create a Folder on a Remote Device. | 4-24 |
| Receive a File from a Remote Device. | 4-24 |
| Delete a File from a Remote Device | 4-24 |
| Send Information via Bluetooth | 4-25 |
| Using Business Cards. | 4-26 |
| Send Business Card. | 4-27 |
| Request Business Cards. | 4-28 |
| Exchange Business Card | 4-28 |
| Work with Connections | 4-29 |
| Create a Shortcut | 4-29 |
| Delete a Shortcut | 4-29 |
| View Shortcuts | 4-30 |
| Open a Connection | 4-30 |
| View Connection Status | 4-30 |
| Close a Connection | 4-31 |
| View Connection Information. | 4-31 |

5 Using the Fingerprint Reader

| | |
|---|------|
| Learn to Enroll a Fingerprint | 5-1 |
| Work with Fingerprints | 5-5 |
| Enroll a Fingerprint | 5-6 |
| Delete a Fingerprint. | 5-9 |
| Set Logon Passwords | 5-10 |
| Set “No password” for Logon | 5-11 |
| Set “Simple 4 digit PIN” for Logon | 5-11 |
| Set “Strong alphanumeric password” for Logon. | 5-12 |
| Set “PIN OR fingerprint” for logon. | 5-13 |
| Set “Password OR fingerprint” for logon | 5-14 |

| | |
|--|------|
| Set “PIN AND fingerprint” for Logon | 5–14 |
| Set “Password AND Fingerprint” for Logon | 5–15 |
| Set “Fingerprint-only” for Logon | 5–16 |
| Logon Using PIN, Passwords, and Fingerprints | 5–17 |
| Logon with No Password | 5–17 |
| Logon Using a 4-digit PIN | 5–17 |
| Logon Using a Password | 5–18 |
| Logon Using a PIN or Fingerprint. | 5–18 |
| Logon Using a PIN and Fingerprint | 5–18 |
| Logon Using a Password or Fingerprint | 5–19 |
| Logon Using a Password and Fingerprint | 5–19 |
| Logon Using a Fingerprint Only | 5–20 |
| Set Security Options. | 5–20 |
| Set the Security Level | 5–21 |
| Set the Maximum Number of Attempts | 5–21 |

6 Connecting

| | |
|---|------|
| Connect to a Computer. | 6–1 |
| Sync with Personal Computer | 6–2 |
| Use the Serial Infrared (IR) Connection | 6–3 |
| Change Synchronization Settings | 6–4 |
| Move Files | 6–6 |
| Connect to the Internet or Your Network | 6–8 |
| Use a Modem Card | 6–8 |
| Synchronize Links | 6–10 |
| Enter an Internet Address (URL). | 6–11 |
| Select from a Favorites List. | 6–12 |

7 Communicating

| | |
|-----------------------------------|-----|
| Work with Contacts | 7–1 |
| Create a Contact. | 7–2 |
| View a List of Contacts | 7–2 |

| | |
|------------------------------------|------|
| Edit Contact Information | 7-3 |
| Categorize Contacts | 7-3 |
| Delete Contacts | 7-6 |
| Use the Inbox | 7-7 |
| Set Up E-mail | 7-8 |
| Compose/Send E-mail | 7-9 |
| Add an Attachment | 7-11 |
| Receive E-mail | 7-12 |
| Open E-mail | 7-13 |
| Delete E-mail | 7-14 |
| Manage Folders | 7-16 |
| Record Voice | 7-17 |
| Make a Recording | 7-18 |
| Listen to a Recording | 7-18 |
| Take Notes | 7-19 |
| Create a Note | 7-19 |

8 Scheduling

| | |
|---|------|
| Use the Today Screen | 8-1 |
| Create Information | 8-2 |
| Change Information | 8-3 |
| Change Settings | 8-4 |
| Use the Calendar | 8-6 |
| Look at the Calendar | 8-6 |
| Change the Calendar View | 8-7 |
| Customize the Calendar Appearance | 8-8 |
| Schedule Appointments | 8-9 |
| Create Reminders | 8-9 |
| Delete Appointments | 8-10 |
| Categorize Appointments | 8-10 |
| Request Meetings | 8-12 |
| Use Tasks | 8-13 |
| Create a Task | 8-13 |
| Create a Task Quickly | 8-14 |

| | |
|--------------------------------------|------|
| Delete a Task | 8-15 |
| Sort Tasks | 8-15 |
| Change Appearance of Tasks | 8-16 |

9 Using Software

| | |
|---|------|
| Use Pocket Word | 9-1 |
| Create a New Document | 9-2 |
| Open a Word Document | 9-4 |
| Change the Pocket Word Options | 9-4 |
| Use Pocket Excel | 9-6 |
| Create a Workbook | 9-7 |
| Open an Excel File | 9-8 |
| Change Excel Options | 9-9 |
| Use Microsoft Reader | 9-10 |
| Activate the Reader | 9-11 |
| Read an eBook | 9-11 |
| Copy eBooks | 9-12 |
| Delete eBooks | 9-13 |
| Listen to an eBook | 9-14 |
| Annotate your eBook | 9-14 |
| Change the Microsoft Reader Options | 9-15 |
| Use the Windows Media Player | 9-17 |
| Copy Music to Your iPAQ Pocket PC | 9-19 |
| Play Music on Your iPAQ Pocket PC | 9-20 |
| Create Playlists | 9-21 |
| Play a Playlist | 9-23 |
| Play Video | 9-23 |
| Use Pocket Internet Explorer | 9-24 |
| Use Pocket IE When Connected | 9-24 |
| Use Pocket IE When Disconnected | 9-24 |
| Synchronize Favorites | 9-25 |

10 Using the Universal Remote

| | |
|--|-------|
| Learn the Icons | 10-2 |
| Use the Configuration Icons | 10-2 |
| Add a Device | 10-3 |
| Change a Device | 10-8 |
| Delete a Device | 10-8 |
| Turn on a Device | 10-9 |
| Add Activities | 10-10 |
| Change an Activity | 10-14 |
| Delete an Activity | 10-14 |
| Set Up a Room | 10-15 |
| Add a Device to a Room | 10-15 |
| Delete a Room | 10-15 |
| Add a Favorite Channel | 10-16 |
| Change a Favorite | 10-16 |
| Set Up User Profile | 10-17 |
| Change a User Profile | 10-17 |
| Download Device Codes and Key Functions. | 10-18 |
| Download Device Codes | 10-18 |
| Download Key Functions | 10-19 |
| Work with Function Keys | 10-19 |
| Add Function Keys | 10-19 |
| Edit Function Keys | 10-19 |
| Learn Function Keys | 10-20 |
| Copy Function Keys | 10-20 |
| Move Function Keys | 10-20 |
| Delete Function Keys | 10-20 |

A Regulatory Notices

| | |
|---|-----|
| Federal Communications Commission Notice. | A-1 |
| Modifications. | A-2 |
| Cables | A-2 |
| Declaration of Conformity for Products Marked with the FCC Logo—United States Only | A-2 |

| | |
|---|-----|
| Canadian Notice | A-3 |
| Avis Canadien | A-3 |
| Japanese Notice | A-3 |
| Battery Warning | A-4 |
| Airline Travel Notice..... | A-4 |
| Wireless Notices | A-4 |
| U.S. Regulatory Wireless Notice..... | A-4 |
| Canadian Regulatory Wireless Notice..... | A-5 |
| European Union Notice | A-5 |
| Brazilian Regulatory Wireless Notice..... | A-7 |

B Hardware Specifications

| | |
|------------------------------|-----|
| System Specifications | B-1 |
| Physical Specifications..... | B-2 |
| Operating Environment | B-3 |

Index

1

Getting Started

Congratulations on purchasing an HP iPAQ Pocket PC. This *Getting Started* guide will help you set up your Pocket PC and familiarize you with how it works.



What is in the Box?



If items are missing, contact Customer Support at the numbers provided in the *Worldwide Telephone Numbers* booklet.

The product ships with:

-
- | | |
|---|--|
| ❶ | HP iPAQ Pocket PC |
| ❷ | Slim Removable Battery |
| ❸ | Protective Cover Pack |
| ❹ | Universal Cradle* for either Universal Serial Bus (USB) or serial connection |
| ❺ | Extra Stylus |
| ❻ | AC Adapter |
| ❼ | Charging Adapter (tethered to the AC Adapter) |
-

(Continued)

(Continued)

⑧ *Getting Started* guide

⑨ *HP iPAQ Pocket PC Companion CD*, which contains:

- Microsoft® ActiveSync® software
- Bonus software and applications
- HP documentation including *HP iPAQ Pocket PC Reference Guide* and eBook in select languages on CD

*The physical appearance of the Universal Cradle may vary slightly depending on the actual model purchased.

Front Panel

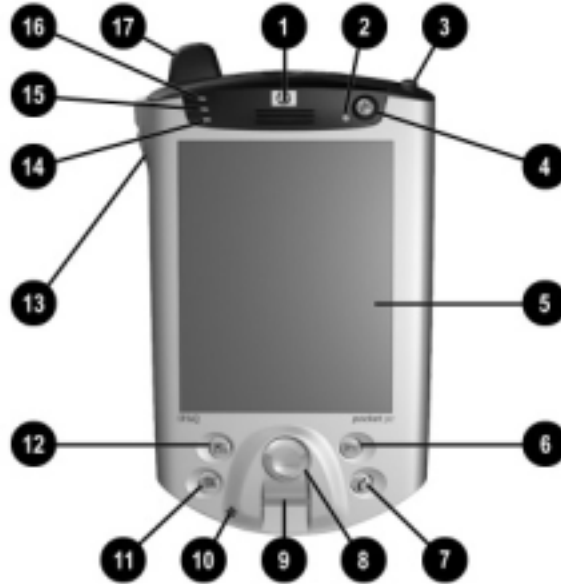

Front Panel Components

- ❶ **Speaker:** Alarms, voice, music

 - ❷ **Power Indicator:**
amber flash = charging
amber solid = charged
green flash = alarm, calendar, event

 - ❸ **Stylus:** Push to eject, push to lock

 - ❹ **Power Button:** Turn unit on and off

 - ❺ **Color Display:** High contrast color screen

 - ❻ ***Inbox Button:** Access your Inbox for sending and receiving e-mail

 - ❼ ***iTask Button:** Open, close, and switch between applications, run utilities, and change settings

 - ❽ **5-Way Navigation Button:** Scroll through a list and push to select (similar to using a joystick)

 - ❾ **Fingerprint Reader:** Biometric enhanced security
-

Front Panel Components *(Continued)*

- ⑩ **Microphone:** Record your voice or other sounds

 - ⑪ ***Calendar Button:** Schedule appointments, set reminders, or view your calendar

 - ⑫ ***Contacts Button:** Display a list of your contacts from the category you select

 - ⑬ **Volume:** Up/Down/Mute Voice and Record

 - ⑭ **Light Sensor:** Automatically adjusts the backlight when selected

 - ⑮ **Active Bluetooth Indicator:** Flashes “blue” when Bluetooth radio is on

 - ⑯ **Wireless LAN Radio Indicator:**
green flash = wireless link
amber flash = no wireless link

 - ⑰ **Antenna:** Transmits and receives signals
-

*These buttons are programmable but at startup they are assigned by default.

Top Panel

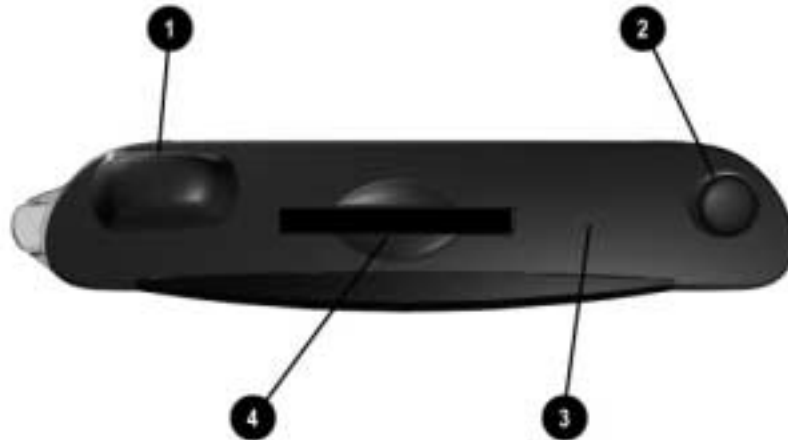

Top Panel Components

- ❶ **Antenna:** Transmits and receives signals
 - ❷ **Stylus:** Push to eject, push to lock
 - ❸ **Infrared/Universal Remote:** Beams information to/from other infrared-enabled devices
 - ❹ **Secure Digital I/O (SDIO) Expansion Slot:** Supports Secure Digital (SD) storage and expansion cards
-

Bottom Panel

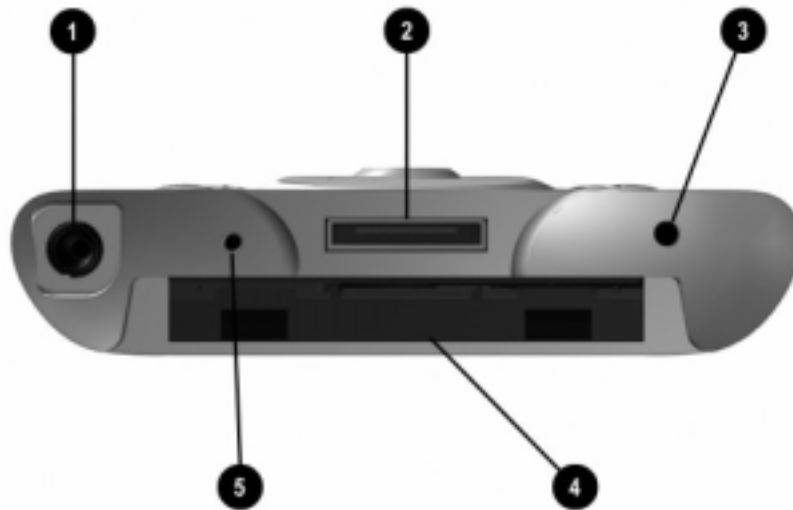

Bottom Panel Components

- ❶ **3.5 mm Stereo/Microphone Headphone Jack:** Connect your headphone or headset or earpiece

 - ❷ **Charging/Communications Port:** Connect to universal cradle, synchronization cable, or charging adapter

 - ❸ **Reset Button:** Resets your iPAQ Pocket PC

 - ❹ **Expansion Pack Connector:** Connect to an optional Expansion Pack

 - ❺ **Microphone:** Record your voice or other sounds
-

Back Panel



Back Panel Components

- ❶ **Slim Removable Battery:** Removable/rechargeable battery
 - ❷ **Battery Latch:** Slide up to remove the battery
 - ❸ **Product Label:** Needed for service and product-related questions
-

Universal Cradle

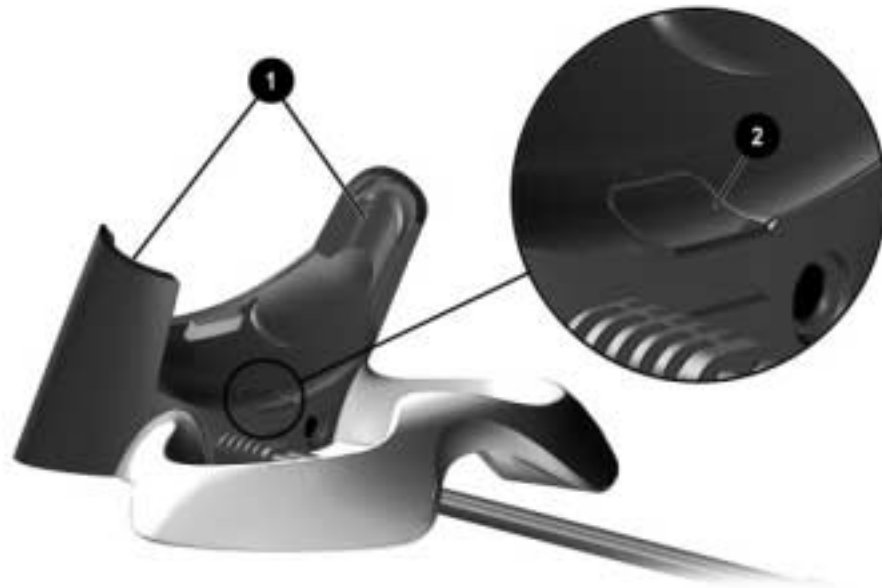

Universal Cradle Components

- ❶ **Stabilizers:** Stabilizes (1) the iPAQ Pocket PC when cradled without an Expansion Pack
 - ❷ **Release Button:** Releases (2) the stabilizers from the locked position
-

Register the hp iPAQ Pocket PC

You can receive the latest information on your iPAQ Pocket PC as well as special offers on iPAQ Pocket PC accessories and software by mailing the owner registration card included in the shipping box (US and Canadian units only).

Set Up Your hp iPAQ Pocket PC

To begin using your HP iPAQ Pocket PC:

1. Locate the removable battery.
2. Insert the tabs **1** on the bottom of the battery into the slots on the iPAQ Pocket PC.
3. Push the battery **2** upward and snap into place.

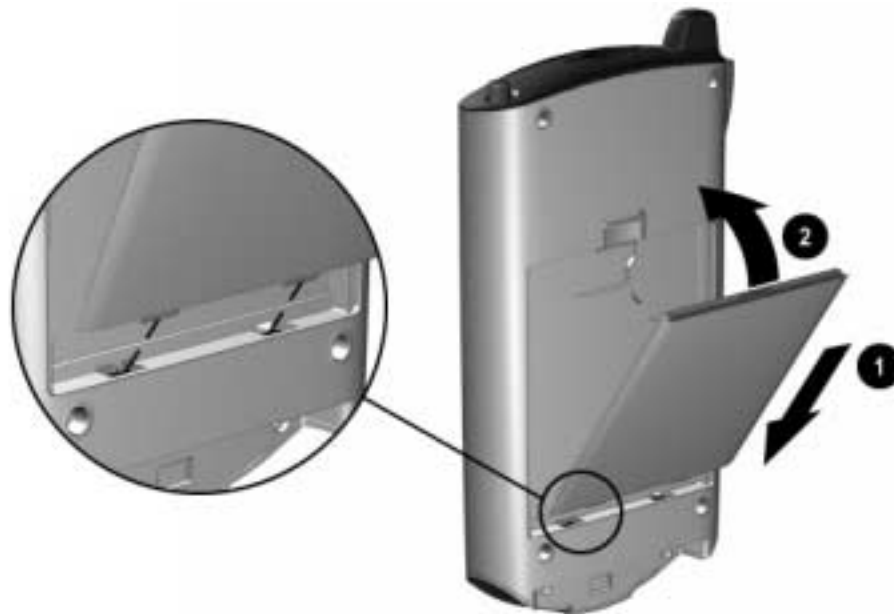

4. Remove the stylus (push down on it) from the slot on the top of the iPAQ Pocket PC.

5. Locate the reset hole on the bottom panel of your Pocket PC. Insert the stylus into the hole and push inward on the stylus to perform a soft reset. Your iPAQ Pocket PC will automatically power on.
6. Follow the steps on the **Welcome** screen to:
 - Align the screen
 - Learn about the stylus
 - Learn about the pop-up menus
 - Select your time zone
7. Tap anywhere to open the **Today** screen.



You will see the **Today** screen when you first turn on your iPAQ Pocket PC each day or after 4 hours of inactivity.

8. Personalize your iPAQ Pocket PC.

Tap to enter
owner information

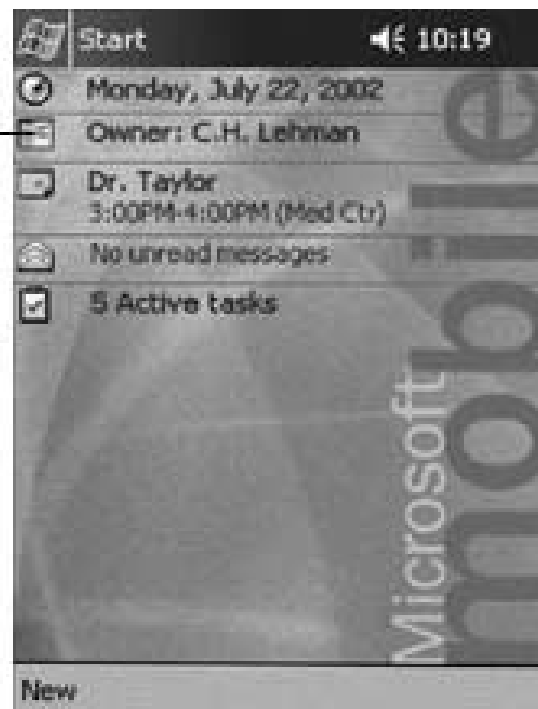

Establish a Partnership

Using Microsoft ActiveSync, you can *synchronize* the information on your personal computer with the information on your iPAQ Pocket PC. Synchronization compares the data on your Pocket PC with your personal computer and updates both computers with the most recent information.

You can *synchronize* your Contacts, Calendar, Tasks, and Notes, which require Microsoft Outlook. Also, you can synchronize other items, such as, files and Web pages, without Microsoft Outlook. Your first synchronization process automatically begins when you finish using the ActiveSync Setup Wizard.

To install ActiveSync:

1. Insert the *HP iPAQ Pocket PC Companion CD* into your computer.
2. Click **Start Here**.
3. Install Microsoft Outlook, if necessary.
4. Click **Install ActiveSync** (version on this CD required as minimum).
5. Follow the instructions on the *HP iPAQ Pocket PC Companion CD*.



When prompted to download the file, select **Run this program from its current location**.

6. Insert the AC Adapter plug into an electrical outlet. Connect the AC connector to the universal cradle.



7. Connect either the (a) serial or the (b) USB connector on the universal cradle to the port on the back or front of your personal computer.

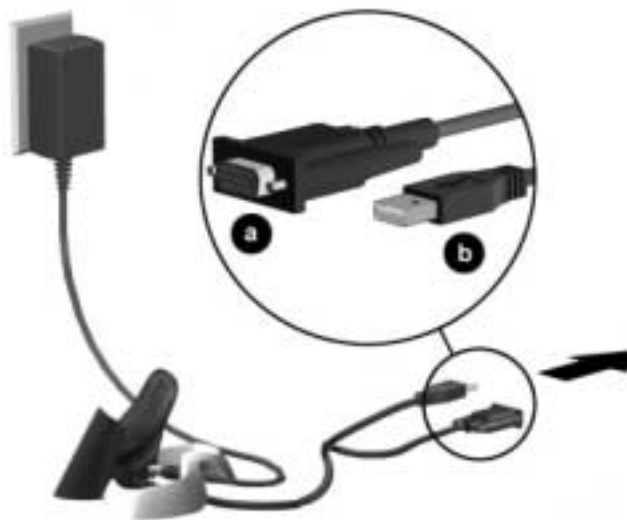

Use either the serial or the USB connector. Do not connect both connectors at the same time.

8. Slide the bottom of your iPAQ Pocket PC into the universal cradle until the connector is fully inserted.



ActiveSync will automatically detect the Pocket PC connection.

9. Continue to follow the ActiveSync instructions to establish a partnership.
10. Learn more about your iPAQ Pocket PC.

For More Product Information

| For information on... | See this source... |
|---|---|
| Programs on your HP iPAQ Pocket PC | The <i>HP iPAQ Pocket PC Reference Guide</i> on CD, and eBook. For Help, tap  then Help . |
| The <i>HP iPAQ Pocket PC Reference Guide</i> | This information is presented in eBook format on your HP iPAQ Pocket PC. |
| Wireless LAN | <i>Wireless LAN Special Features Guide</i> in the box and Chapter 3: <i>HP iPAQ Pocket PC Reference Guide</i> on CD |
| Bluetooth | <i>Bluetooth Special Features Guide</i> in the box and Chapter 4: <i>HP iPAQ Pocket PC Reference Guide</i> on CD |
| Fingerprint Reader | Chapter 5: <i>HP iPAQ Pocket PC Reference Guide</i> on CD |
| iPAQ Backup | Chapter 2: <i>HP iPAQ Pocket PC Reference Guide</i> on CD |
| Universal Remote Control | Chapter 10: <i>HP iPAQ Pocket PC Reference Guide</i> on CD |
| iPAQ File Store | Chapter 2: <i>HP iPAQ Pocket PC Reference Guide</i> on CD |
| iTask Manager | Chapter 2: <i>HP iPAQ Pocket PC Reference Guide</i> on CD |
| Additional programs that can be installed on your HP iPAQ Pocket PC | The <i>HP iPAQ Pocket PC Companion CD</i> |
| Information about HP iPAQ Pocket PC options | The <i>Accessories Information</i> brochure included with your HP iPAQ Pocket PC or http://www.hp.com/products/pocketpc/options |
| Information on your HP iPAQ Pocket PC | http://www.hp.com/products/pocketpc |

| For information on... | See this source... |
|---|---|
| Up-to-date information on your Microsoft Pocket PC 2002 software | http://www.microsoft.com/mobile/pocketpc |
| Programs that are already on your HP iPAQ Pocket PC | The <i>HP iPAQ Pocket PC Companion CD</i> and Help on your HP iPAQ Pocket PC. Tap Start , then Help . |
| Connecting your HP iPAQ Pocket PC to a computer | This <i>Getting Started</i> guide, the <i>HP iPAQ Pocket PC Reference Guide</i> , or ActiveSync Help on the <i>HP iPAQ Pocket PC Companion CD</i> . |
| Register your HP iPAQ Pocket PC to receive e-mail from HP pertaining to special offers and promotions | Owner Registration Card in North America or http://www.hp.com/support/registration |
| Warranty and service information | Worldwide Limited Warranty Statement in the box. |

Troubleshooting and Support Information

| For information on... | See this source... |
|---|---|
| Connecting to and synchronizing with a computer | ActiveSync Help on your personal computer. To view Help , start ActiveSync, click Help , then click Microsoft ActiveSync Help . |
| Troubleshooting information on ActiveSync connections | The ActiveSync troubleshooter on your computer. After installing the desktop software. Click Help , then Troubleshooter . |
| Exchanging files after synchronizing your HP iPAQ Pocket PC | Online ActiveSync on your computer. View the online help by opening Microsoft ActiveSync on your computer, then select Help, Microsoft ActiveSync Help . |
| Last-minute updates and detailed technical information | The Read Me files, located in the Microsoft ActiveSync folder on the <i>HP iPAQ Pocket PC Companion CD</i> . |
| Support for your HP iPAQ Pocket PC | http://www.hp.com/support/pocketpc |
| Safety Information | Important Safety Information in the <i>HP iPAQ Pocket PC Reference Guide</i> . |
| Up-to-date information on Windows-powered devices | http://www.microsoft.com/pocketpc |

Getting Acquainted

To use your HP iPAQ Pocket PC h5400 Series most effectively, start by learning how to:

- Enter information
- Customize settings
- Manage your iPAQ Pocket PC
- Manage the battery
- Work with applications

Enter Information

You can enter letters, symbols, and numbers on the iPAQ Pocket PC screen by:

- Tapping the keyboard
- Writing with the stylus and using the Letter Recognizer, Transcriber, or Block Recognizer to create text
- Drawing and writing with the stylus

You can tap the keyboard or write with the Letter Recognizer, Transcriber, or Block Recognizer in any application. You can use the stylus to draw and write on the screen in the Notes application and from any **Notes** tab in the Calendar, Contacts, and Tasks applications.



As you type or write, the iPAQ Pocket PC suggests words for you in a box above the Keyboard, Letter Recognizer, or Block Recognizer but not in the Transcriber.

You can determine when the suggestions occur (for example, you can decide how many letters to enter before the Letter Recognizer makes suggestions) and how many words are suggested.

Change Word Suggestion Options

You can determine:

- If words are suggested
- The number of letters you must enter before a word is suggested
- The number of words that are suggested per entry
- If you do not want any words suggested

To change word suggestions:

1. From the **Start** menu, tap **Settings**.
2. Tap **Input**.
3. Tap the **Word Completion** tab.

- Determine how many letters you want to type before a suggestion is made, then tap the down arrow associated with letters.

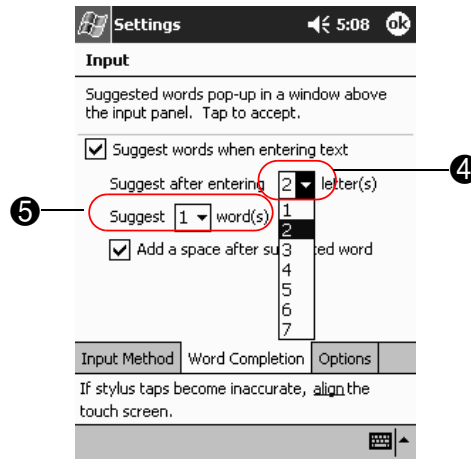

- Determine how many words you want suggested, then tap the down arrow associated with words.
- Tap **OK**.

Type with the On-Screen Keyboard

You can enter typed text directly on the screen by tapping letters, numbers, and symbols on the keyboard.

To type with the keyboard:

1. From any application, tap the up arrow next to the **Input Panel** icon.

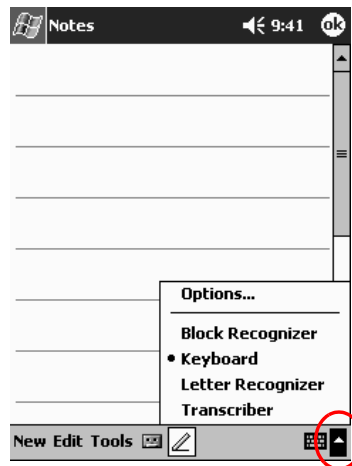

2. Tap **Keyboard** to display a keyboard on the screen.

3. Tap a letter, symbol, or number to enter information.

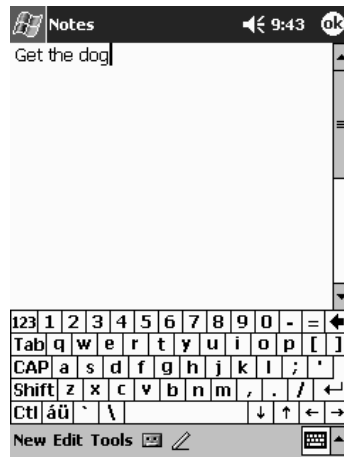

To see the symbols, tap the **123** or **Shift** key.

4. Tap **OK**.

Write with the Stylus and the Letter Recognizer

You can write letters, numbers, and symbols on the screen using the stylus and the Letter Recognizer. You create words and sentences by writing in upper case (ABC), lower case (abc), and symbols (123) in specific areas.

To write with the stylus and letter recognizer:

1. From any application, tap the up arrow next to the **Input Panel** button.

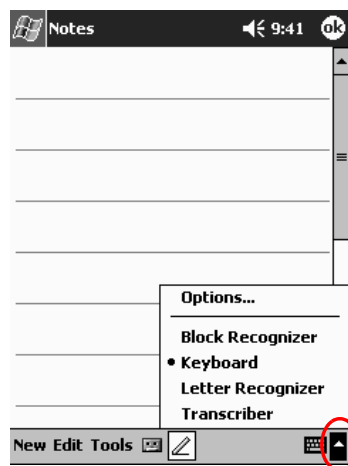

2. Tap **Letter Recognizer**.

3. Write a letter or symbol between the dashed line and baseline.
 - a. Write a letter between the hatch marks labeled **ABC** to display in upper case.
 - b. Write a letter between the hatch marks labeled **abc** to display in lower case.
 - c. Write a number or symbol between the hatch marks labeled **123**.

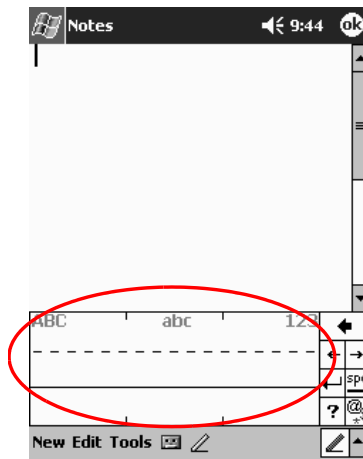

You should write characters between the dashed line and baseline for the character recognizer to work effectively. If you are writing a letter like “p,” write the top portion within the dashed line and baseline, and the tail portion below the baseline.

If you writing a letter like “b,” write the bottom portion within the dashed line and baseline, and the top portion above the dashed line.

4. What you write will be converted to text.

Write with the Stylus and the Transcriber

You can write words, letters, numbers, and symbols anywhere on the screen using the stylus and Transcriber.

To write with the stylus and transcriber:

1. From any application, tap the up arrow next to the **Input Panel** button.
2. Tap **Transcriber**.
3. Write on the screen.
4. What you write will be converted to text.

Write with the Stylus and Block Recognizer

You can write letters, numbers, and symbols using the stylus and Block Recognizer. You create words and sentences by writing letters and numbers in specific areas.



You can input character strokes you learned using Graffiti.®

To write with stylus and block recognizer:

1. From any application, tap the up arrow next to the **Input Panel** button.
2. Tap **Block Recognizer**.
3. Write a word, letter, or symbol in the input box.
 - a. Write a letter in the input box labeled “abc” to type text.
 - b. Write a number or symbol in the input box labeled “123” to type numbers or symbols.

What you write will be converted to text.

Draw and Write on the Screen

Use the stylus as a pen to draw and write on the screen in the Notes application or from the **Notes** tab in Calendar, Contacts, or Tasks.

To draw and write on the screen:

1. From the **Start** menu, tap **Notes**.
2. Tap **New**.



Otherwise, tap the **Notes** tab in Calendar, Contacts, or Tasks, then tap the **Pen** icon.



3. Draw and write on the screen.

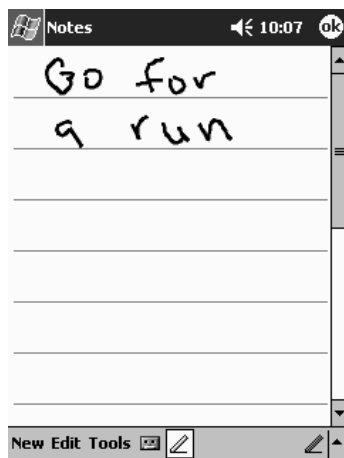

4. Tap the **Pen** icon.
5. Tap **OK**.

Convert Writing to Text

Convert your writing to text when you write with the stylus in the Notes application or from the **Notes** tab in:

- Calendar
- Contacts
- Tasks

To convert writing to text:

1. From the **Start** menu, tap **Notes**.



Otherwise, tap the **Notes** tab in Calendar, Contacts, or Tasks.

2. Begin a new note or tap an existing note to open it.
3. Tap **Tools**, then **Recognize**.



To convert a particular word or phrase, highlight it before you tap **Recognize**. If you select more than one word and one is not recognized, all the other words will be converted. The unrecognized word will remain written.

4. Tap **OK**.

Customize Settings

You can navigate through the iPAQ Pocket PC interface in 3 ways:

- Tap
- Tap and hold
- Press application buttons

Tap the screen with the pointed tip of your stylus to open applications and make selections. For example, tap the **Start** menu to see a list of applications available.

Tap and hold an area on the screen to see a pop-up menu.

Press an application button on the front panel to quickly turn on the screen and open your Calendar, Contacts, Inbox, or iTask, if you have not changed the default settings for the buttons.

Set the Time for Home

The time on your iPAQ Pocket PC is synchronized with the time on your personal computer when they connect using ActiveSync. You will need to set the time again if:

- The battery completely discharges.
- You perform a full reset of your iPAQ Pocket PC. See “Perform a Full Reset.”



From the **Today** screen, tap the **Clock** icon to set the time.

To set the time for home:

1. From the **Start** menu, tap **Settings**.
2. Tap **System**, then **Clock**.



By default, the time on the host computer is synchronized with the iPAQ Pocket PC each time the 2 devices connect using ActiveSync.

3. Verify **Home** is selected or tap **Home**.

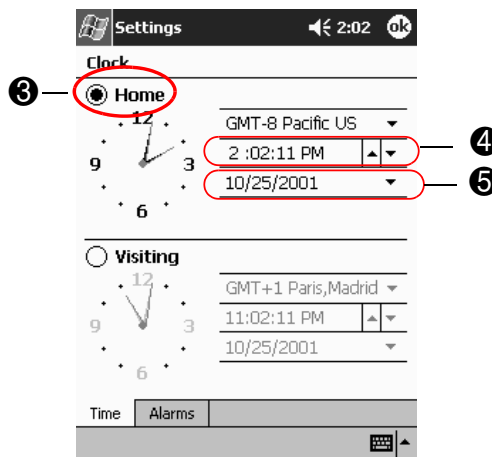

4. Tap the time-zone down arrow, then select your home time zone.
5. Tap the hour, minutes, or seconds, then use the up and down arrows to adjust the time.



You can adjust the time by moving the hands of the clock with the stylus.

6. Tap **AM** or **PM**.
7. Tap **OK**.
8. Tap **Yes** to save the clock settings.

Set the Time for a Location You Are Visiting

Set the time for a location you are visiting.



From the **Today** screen, tap the **Clock** icon to set the time.

To set the time for visiting location:

1. From the **Start** menu, tap **Settings**.
2. Tap **System**, then **Clock**.
3. Tap **Visiting**.

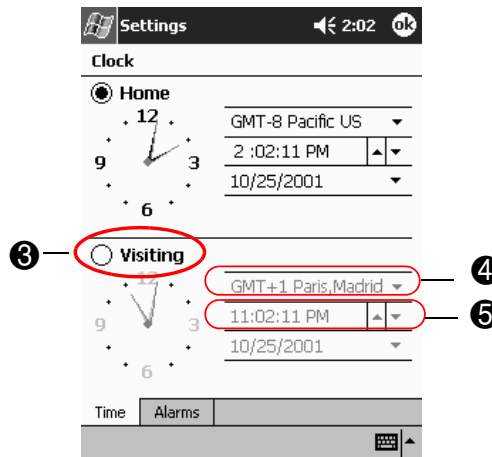

4. Tap the time-zone down arrow, then select the time-zone you are visiting.
5. Tap the hour, minutes, or seconds, then use the up and down arrows to adjust the time.



You can adjust the time by moving the hands of the clock with the stylus.

6. Tap **AM** or **PM**.
7. Tap **OK**.
8. Tap **Yes** to save the clock settings.

Set the Date

You must set the date again if:

- The battery discharges completely
- You perform a full reset of your iPAQ Pocket PC



You can set the date from the **Today** screen. Tap the **Clock** icon to set the date.

To set the date:

1. From the **Start** menu, tap **Settings**.
2. Tap **System**, then **Clock**.
3. Tap the down arrow by the date.
4. Tap the left or right arrow to select a month and year.



5. Tap a day.
6. Tap **OK**.
7. Tap **Yes** to save the date settings.

Change the Backlight Settings

You can change the backlight settings to match your environment or to conserve battery power.



The backlight settings on your iPAQ Pocket PC are synchronized with the settings on your personal computer when they connect using ActiveSync.

To change the backlight settings:

1. From the **Start** menu, tap **Settings**.
2. Tap **System**, then **Backlight**.
3. Select the backlight settings.



Changing the Backlight Settings

| On the... | Select when to use the... |
|---------------------------|--|
| Battery Power tab | Backlight on battery power. |
| External Power tab | Backlight on external power. |
| Brightness tab | <ul style="list-style-type: none">• Appropriate level of brightness. Slide the bar to the lowest level to conserve the most power.• Automatic light sensor. Select the check box to disable the slider bar and allow the brightness to automatically adjust to the ambient light. |

Manage Your iPAQ Pocket PC

You can effectively manage your iPAQ Pocket PC by learning how to:

- Back up and restore information
- Use the iPAQ File Store
- Perform full and normal resets
- Align the screen
- Perform a self-test

Back Up Information

You can back up information to the personal computer, the iPAQ File Store, and storage cards using:

- iPAQ Backup
- Active Sync

Use iPAQ Backup

iPAQ Backup protects your data from hardware failures, loss of battery power, and accidental deletions.

Using iPAQ Backup, you can:

- Back up and restore selected files, folders, and databases on your Pocket PC
- Copy the entire contents of the Pocket PC (for example, the registry, user and system databases, and data files)
- Schedule regular backup
- Back up your PIM



WARNING: Restoring your information replaces the current information on your iPAQ Pocket PC with the information saved in your backup.

Back up Files, Registry, and Databases

You can back up files, registry, and databases. A backup file can be saved to any media (for example, storage card or hard drive) that you would use for storing any other file.

To back up files, registry, and databases:

1. From the **Start** menu, tap **Programs**.
2. Tap **iPAQ Backup**.
3. Tap the check boxes to select files, folders, or databases from the tree view.

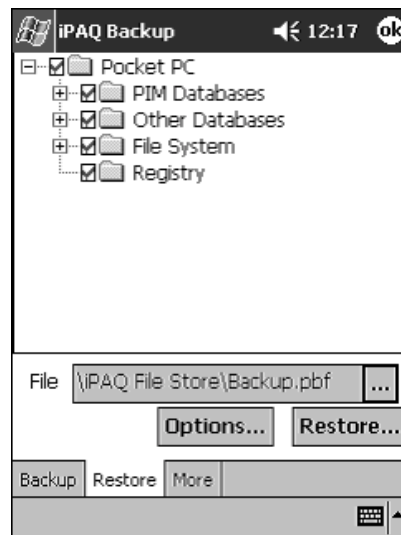

4. Tap the ... button.

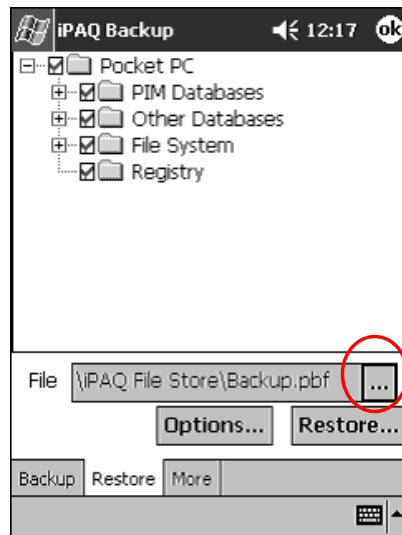

5. Enter a name and saving location for the back up data, then tap **OK**.

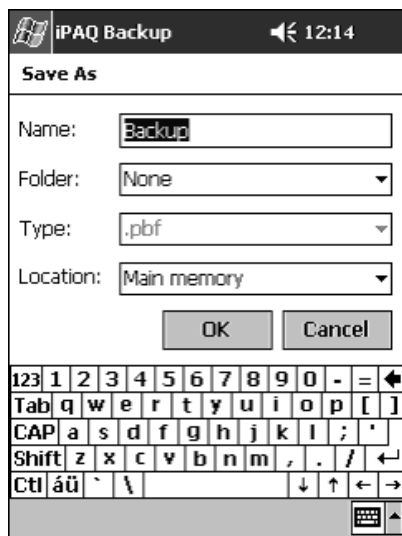

6. Tap **Options...** to set backup options.

7. Select whether to:
 - a. Compress and/or encrypt data
 - b. Exclude files from the backup

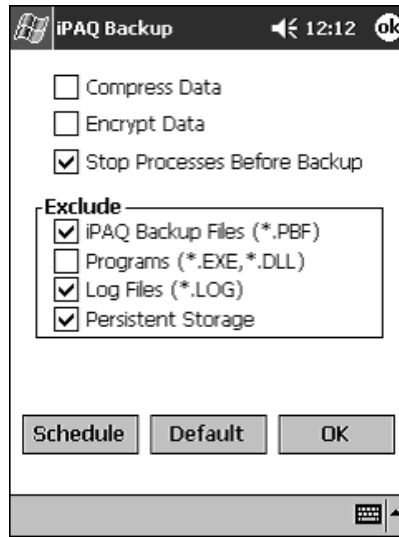

Selecting Back Up Options

| If you select... | Then... |
|----------------------------|--|
| Compress Data | The backup file will be smaller, but the process will take longer. |
| Encrypt Data | The backup file (*.sif) will be encrypted. The user must enter an alphanumeric password (6-15 digits) to proceed with the backup then re-enter the password to restore the data. |
| Stop Process Before Backup | All active applications will be closed prior to the backup. |
| Exclude | iPAQ backup (*.sif), program (*.exe and *.dll), log (*.log), and storage card files are excluded from the backup. |

8. Tap **OK**.
9. Tap the **Backup...** button.
10. Tap the **Start** button.

Restore Back Up Files, Registry, and Databases

1. From the **Start** menu, tap **Programs**.
2. Tap **iPAQ Backup**.
3. Tap the **Restore** tab.

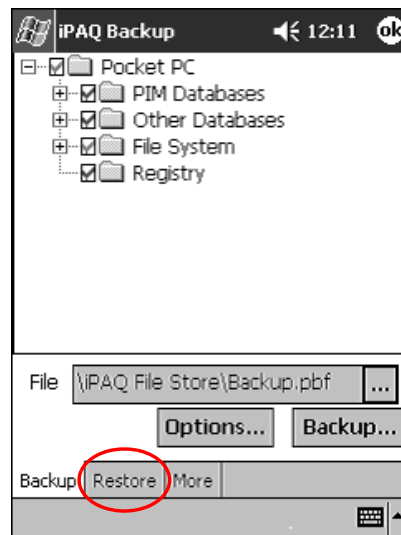

4. Tap the ... button in the **File** field.

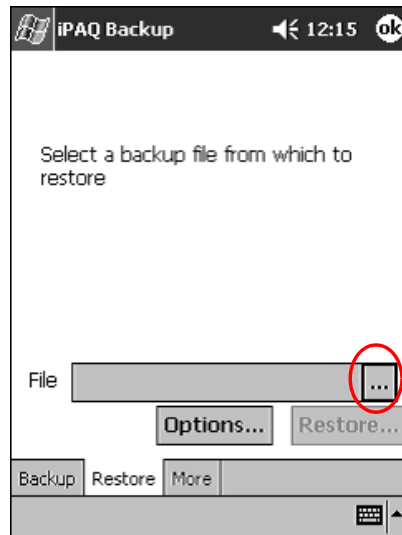

5. Select a file that you have backed up.

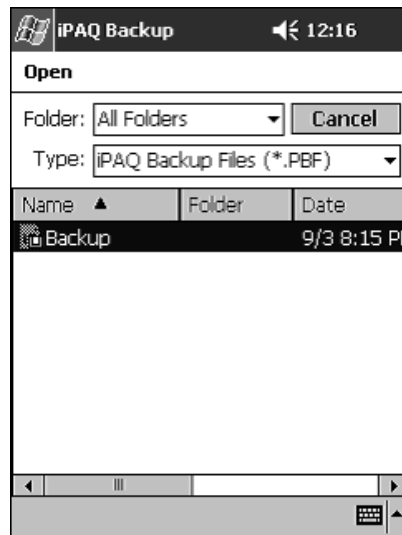

6. Select the data you want to restore from the tree view.

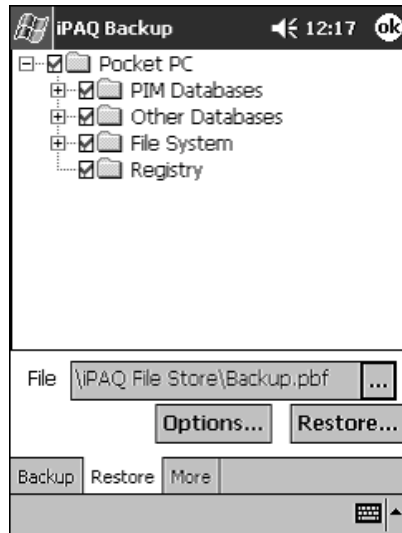

7. Tap **Options...** to set restore options.



It is recommended that you close all applications prior to restoring files.

8. Tap **OK**.

9. Tap the **Restore** button.

10. Tap the **Start** button.

Schedule a Backup

You can schedule an automatic backup to run at a certain time and date.

To schedule a backup:

1. From the **Start** menu, tap **Programs**.
2. Tap **iPAQ Backup**.
3. Tap the **Backup...** tab.

4. Tap the **Options** button.

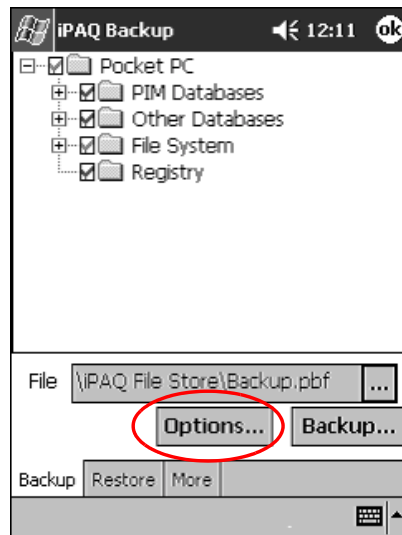

5. Tap the **Schedule** button.

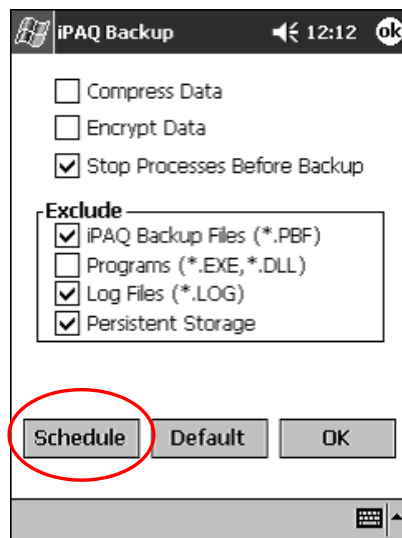

6. Tap the check box **Enable Scheduled Start Up**.

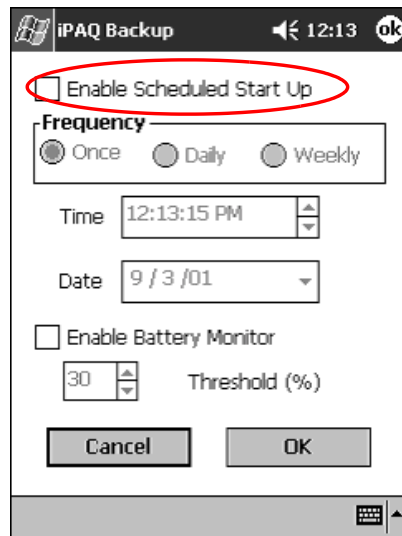

7. Select 1 of the **Frequency** radio buttons.

Selecting a Frequency for Backup

| If you select... | Then the backup will... |
|-------------------------|---|
| Once (default) | Begin at a designated future time and date. |
| Daily | Occur at the same time each day. |
| Weekly | Occur on a scheduled day at a certain time each week. |

8. Tap **OK**.

Back Up/Restore Using Active Sync

You should back up information to your computer regularly to help reduce the chance of losing information.

Close all applications on your iPAQ Pocket PC before restoring your information.



WARNING: Restoring your information replaces the current information on your iPAQ Pocket PC with the information saved in your backup.

To back up/restore using ActiveSync:

1. Make sure your iPAQ Pocket PC is connected to your computer.
2. From your computer, open Microsoft ActiveSync. From the **Start** menu, click **Programs**, then click **Microsoft ActiveSync**.
3. From the **Tools** menu, click **Backup/Restore**.

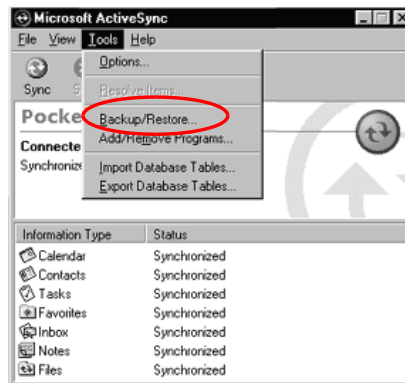

4. Click the **Backup** or **Restore** tab, then select your options.

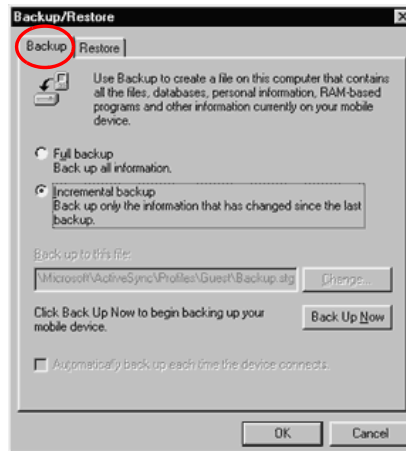

5. Click **Backup Now** or **Restore Now**.

Save to a SD or CompactFlash Card

1. Insert SD or CompactFlash card.
2. Open file you want to save.
3. Tap **Options**.
4. Tap down arrow, then tap SD card.
5. Tap **Save**.

Use the iPAQ File Store

You can install applications and save files to the iPAQ File Store folder. The iPAQ File Store is accessed from the File Explorer on your iPAQ Pocket PC.

Applications and files stored in the iPAQ File Store are held in ROM and are saved if you perform a full reset of your iPAQ Pocket PC or if the battery discharges completely.



Beware that registry changes will not be saved if you perform a full reset or if the battery discharges completely.

The iPAQ File Store can store up to 20 MB of information, depending on the model.

Save to the File Store

1. Copy the files you want to save to the File Store.
2. From the **Start** menu, tap **Programs**.
3. Tap **File Explorer**.
4. Tap **My Device**.
5. Tap **File Store**.
6. Paste selected files.

Perform a Full Reset

A full reset is sometimes referred to as a “hard reset.” You should perform a full reset when you want to clear all settings, programs, and data from RAM.

A full reset will de-activate the battery. The power button will not function until the battery is reactivated.



Programs and data stored in iPAQ File Store are not automatically deleted. You must manually delete the files.

To perform a full reset:



CAUTION: If you perform a full reset, you will return to your default settings and lose all information not in ROM.

1. Press and hold the 1 and 4 application buttons.



2. Press the **Reset** button on the bottom of the iPAQ Pocket PC with the stylus.
3. Hold all buttons until the displayed image begins to fade (approximately 4 seconds).
4. Release the application buttons and stylus.



You can verify a full reset by pressing the power button. If the iPAQ Pocket PC has been fully reset, it will not turn on.

5. Reactivate the battery by:
 - Removing and reinstalling the battery
 - Connecting the iPAQ Pocket PC to AC power
 - Pressing the **Reset** button with the stylus
6. Set up your iPAQ Pocket PC.

Perform a Normal Reset

A normal reset is sometimes referred to as a “soft reset.” You perform a normal reset when you want to stop all running applications. A normal reset will not erase any programs or data stored in RAM or ROM.



CAUTION: A normal reset will erase all unsaved data.

To perform a normal reset:

1. Locate the reset button on the bottom of the iPAQ Pocket PC.
2. Lightly press the normal reset button for 2 seconds.



The iPAQ Pocket PC will restart in approximately 5 seconds and display the **Today** screen.

Align the Screen

When you turn on the screen of your iPAQ Pocket PC for the first time, you are guided through the alignment process. Realign your screen if:

- The iPAQ Pocket PC does not respond accurately to your taps
- You performed a restore following a data backup
- You performed a hard reset of your iPAQ Pocket PC

To align the screen:

1. From the **Start** menu, tap **Settings**.
2. Tap **System**, then the **Screen** icon.
3. Tap the **Align Screen** button.
4. Tap the cross object at each location. Be precise when you tap the cross object.
5. Tap **OK**.

Use the Self-Test

You can use the self-test to verify the proper operations of various features and functions. Technical support may ask to perform this test while they are troubleshooting problems.

To perform a self-test:

1. From the **Start** menu, tap **Settings**.
2. Tap the **System** tab, then **Self-test**.
3. Select the tests you want to perform. The default is all tests.
4. Tap **Next**.
5. Select “**Perform an Automatic Reset before the test.**”
6. Tap **Next** to begin the test.

7. Follow the on-screen instructions.
8. Tap **Finish** to exit.
9. Tap **Yes** to save a test log file to the **My Documents** folder.
10. Tap **OK** to exit.

Manage the Battery

To use your battery power effectively, you need to know how to:

- Install the battery
- Monitor the battery
- Charge the battery
- Change the removable battery packs
- Reactivate the battery



You should recycle and dispose of the lithium polymer battery properly.

Install the Battery

1. Locate the battery.
2. Insert the battery tabs into the slots on the iPAQ Pocket PC.
3. Push the battery into slots.



You will need to fully charge your iPAQ Pocket PC within the next 12 hours. The amber charge light blinks when your iPAQ Pocket PC is recharging the battery. The amber charge light is solid (nonblinking) when the battery is fully charged.

Automatically Monitor the Battery

You can automatically monitor the state of the battery and be notified when the battery falls below a specified threshold. You can then elect to:

- **Dismiss** which cancels the notification and battery monitoring service
- **Snooze** for a certain period of time then receive the battery notification again
- **Run** which starts the iPAQ Backup program

To automatically monitor the battery:

1. From the **Start** menu, tap **Programs**.
2. Tap **iPAQ Backup**.
3. Tap the **Backup...** tab.
4. Tap the **Options** button.

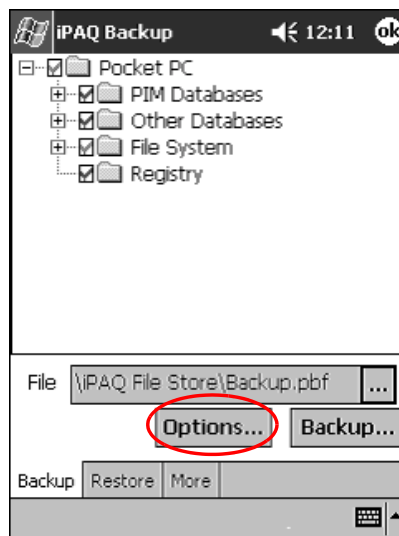

5. Tap the **Schedule** button.

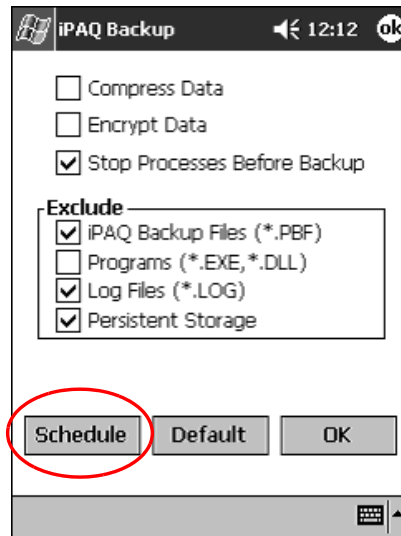

6. Select **Enable Battery Monitor**.

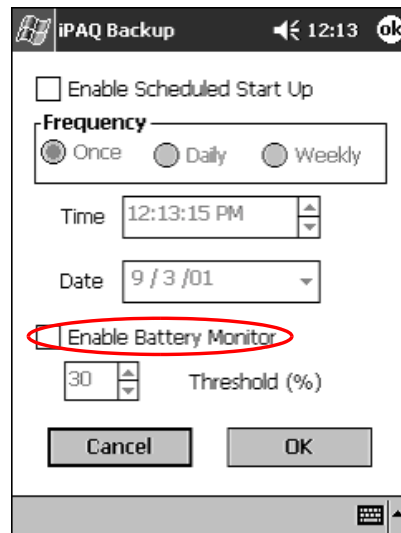

7. Select a **Threshold (%)** value.



The **Threshold (%)** value must be between 90% and 10%.

8. Tap **OK**.

Manually Monitor the Battery

You can manually monitor the battery power.

1. From the **Start** menu, tap **Settings**.
2. Tap **System**, then **Power**.
3. Tap **OK**.

Charge the Battery

Because your iPAQ Pocket PC uses some power to maintain files in RAM and the clock, you need to recharge the battery regularly. Keep the iPAQ Pocket PC connected to the universal cradle or the AC Adapter while you are at your desk.

The best policy is to keep the iPAQ Pocket PC connected to your computer when working at your desk and carry your AC Adapter and charging adapter plug with you when traveling.

Your iPAQ Pocket PC is shipped with a partial charge on the battery. You may want to ensure that it is fully charged before synchronizing.



CAUTION: Because most of the applications and data you install on your iPAQ Pocket PC are held in memory (RAM), you will need to reinstall them if the battery completely discharges.

We recommend that you fully charge the battery prior to synchronizing with your personal computer.

Charge with the Universal Cradle

You can charge your iPAQ Pocket PC with it docked in the universal cradle. Use the universal cradle to recharge the battery of an optional expansion pack, if you have purchased one.

To charge with the universal cradle:

1. Plug the AC Adapter of the universal cradle into an electrical outlet.
2. Slide the bottom of your iPAQ Pocket PC into the universal cradle until the connector is fully inserted.



The amber charge light blinks when your iPAQ Pocket PC is recharging the battery. The amber charge light is solid (nonblinking) when the battery is fully charged.



Charge with the AC Adapter

You can charge your iPAQ Pocket PC using the AC Adapter and the charger adapter. The AC Adapter works in any standard electrical outlet.

If you purchased an optional expansion pack, you can also use the AC Adapter to recharge the battery of an optional expansion pack.

When traveling, you can purchase an adapter that works in your car's cigarette lighter or a 12-volt power outlet.



CAUTION: Use only HP recommended AC adapters.

To charge with the AC Adapter:

1. Plug the AC Adapter into an electrical outlet.
2. Insert the AC Adapter plug into the charging adapter.
3. Insert the charging adapter into the bottom of your iPAQ Pocket PC.



When inserting the charging adapter ensure that the triangle markings (located on the front of the charging adapter) are on the same side as the iPAQ screen.





CAUTION: Incorrectly inserting the charging adapter plug into the connector on the bottom of the iPAQ Pocket PC can damage the connector pins.

To avoid damage to the connector pins when removing the charging adapter from the bottom of the iPAQ Pocket PC, push the release buttons located on each side of the adapter and pull.

Adjust the Standby Setting

You can adjust the portion of the battery devoted to the “standby period.” Standby is your battery reserve that is used to protect the data and applications stored in RAM.

During standby, the unit turns off so very little power is being consumed. This helps to preserve programs and data stored in the RAM.

You can select a lower standby period if you use the Pocket PC for extended periods of time. A lower standby period increases the usable battery operating time.

You can select a higher standby period if you leave your Pocket PC off for extended periods of time without recharging it. A higher standby period decreases the usable battery time and allocates it for standby usage.



For more information on using the Standby Setting, tap **Help** from the **Start** menu.

To adjust the standby setting:

1. From the **Start** menu, tap **Settings**.
2. Tap **System**, then the **Power** icon.

3. Tap the **Standby** tab.
4. Drag the pointer to adjust the standby period.

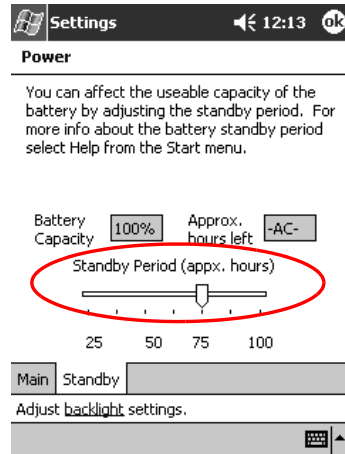

Change the Battery Pack

If the main battery for your iPAQ Pocket PC is removed, your device will not operate even if you try to use AC power.

You can change the battery without losing the data. However, any wireless communication will be terminated.

It is recommended that you replace the battery within 30 minutes.

Reactivate the Battery

A full reset will deactivate the battery. The power button will not function until the battery is reactivated.

You reactivate the battery by:

- Removing and reinstalling the battery
- Connecting the iPAQ Pocket PC to AC power
- Pressing the normal reset button with the stylus

Work with Applications

You can open, minimize, and close applications.

Open Applications

Most applications on your iPAQ Pocket PC are only 2 taps away from any screen. Open any application on your iPAQ Pocket PC from the **Start** menu.



CAUTION: If an application has been added to the **Start** menu, it will not display on the **Programs** menu.



You can open an application by assigning it to an application button.

To open an application:

1. Tap **Start** or the **Microsoft** logo.
2. Tap **Programs**.
3. Tap the application title or icon.

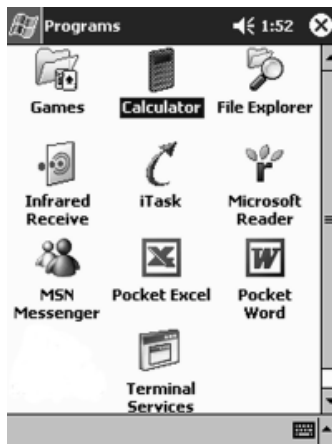

Minimize Applications

From the application you would like to minimize, tap the **X** in the top right corner.

Close Applications

Applications may close automatically as you open new applications. This will depend on the amount of RAM being used.

If your iPAQ Pocket PC is running slowly, you can manually close applications.

To close an application:

1. From the **Start** menu, tap **Settings**.
2. Tap **System**, then **Memory**.

3. Tap the **Running Programs** tab.

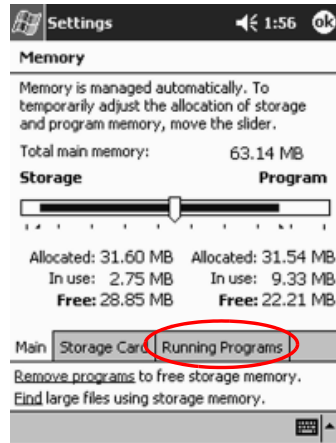

4. Tap **Stop All** or select a particular application, then tap **Stop**.



You can close active programs using iTask.

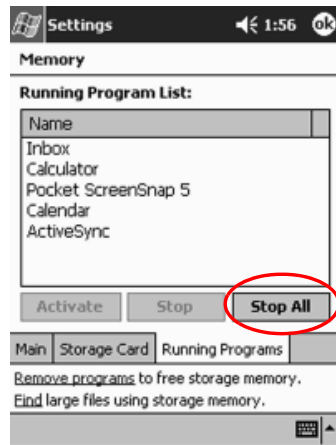

Install Applications

You can install applications on your iPAQ Pocket PC from your:

- Computer by using Microsoft ActiveSync
- iPAQ Pocket PC if the application file has a .cab extension
- iPAQ Pocket PC or your computer by copying an application file that has an .exe or .cef extension

When installing applications, look for the correct version for the iPAQ Pocket PC.



CAUTION: If an application has been added to the **Start** menu, it will not display on **Programs** menu.

To install applications:

1. Tap the application file to install and move it to the **Programs** folder on your iPAQ Pocket PC.
2. Follow the instructions in the installation wizard to install the program on your iPAQ Pocket PC.
3. If your application does not run, insert the stylus for 2 seconds into the **Reset** button on the bottom of your iPAQ Pocket PC.

Customize the Application Buttons

You can quickly open your Calendar, Contacts, Inbox, or iTask applications by pressing an application button on the front panel of your iPAQ Pocket PC. If you want to open other applications with those buttons, then you must change the default assignments.

To customize the application buttons:

1. From the **Start** menu, tap **Settings**.
2. Tap **Buttons**.

3. Tap the button you want to change.

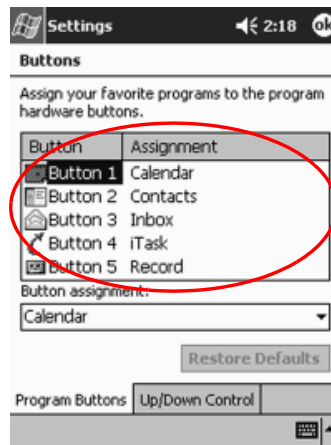

4. Tap the **button-assignment** down arrow.

5. Tap an application.



6. Tap **OK**.

View Images

You can use the **iPAQ Image Viewer** to view images with BMP, JPEG, and GIF file extensions.

Using the Image Viewer, you can:

- Create a slide show of images
- Sort and rotate images
- Adjust the timing between images in a show
- Set a variety of transition effects

Locate an Image

1. From the **Start** menu, tap **Programs**.
2. Tap **iPAQ Image Viewer**.
3. Tap **File**, then **Look In**.

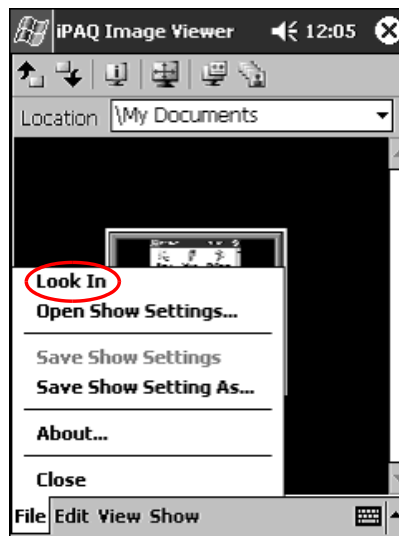

4. Select a file from the tree structure, then tap **OK**.

View Image Information

You can view the image size and type, date taken and modified, color, and file size of an image.

To view image information:

1. Locate an image (see section “Locate an Image”).
2. Tap image to select it.
3. Tap **View**, then **Information Window**.

Change the View

Images are displayed in the thumbnail view by default. The Image Viewer opens showing the images in the **Thumbnail View**. This is the default setting when opening images in the Image Viewer.

You can change the view to full screen by:

- Double clicking a thumbnail
- Tapping **View**, then **Full Screen**
- Tapping the **View Full Screen** icon

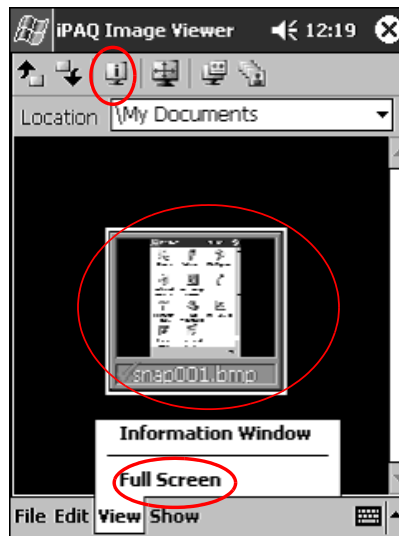

Create a Slide Show

You can put images together to create a slide show and control display options like:

- Orientation
- Zoom
- Image Quality
- Transition Effect
- Timing

To create a slide show:

1. From the **Start** menu, tap **Programs**.
2. Tap **iPAQ Image Viewer**.
3. Tap **Show**, then **Set up Show....**
4. Select images for the show and modify any image settings.

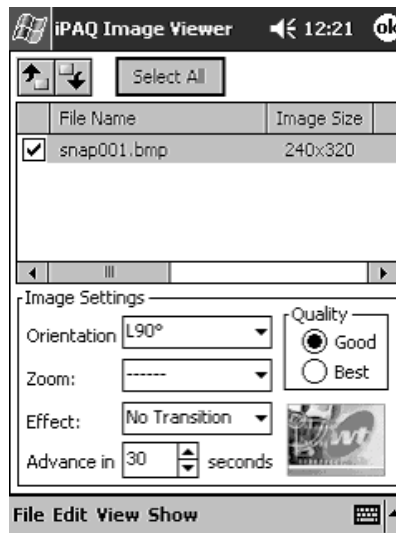

To change settings for all images in the show, click the **Select All** button.

5. Tap **OK**.

Save a Slide Show

You can save the show settings and use them again.

To save a slide show:

1. From the **Start** menu, tap **Programs**.
2. Tap **iPAQ Image Viewer**.
3. Create slide show (see section “Create a Slide Show”).
4. Tap **File**, then **Save Show Settings** or **Save Show Settings As....**

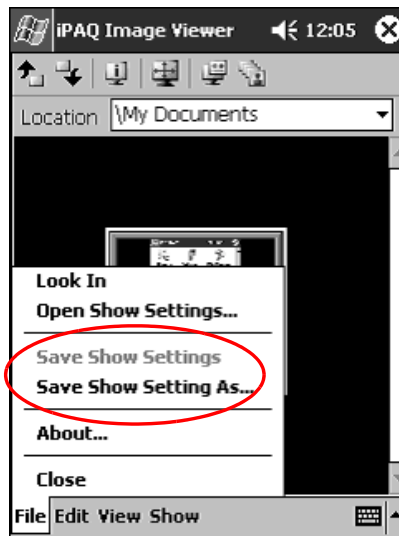

5. Enter the name and location where you want to save the settings.
6. Tap **OK**.

Open a Slide Show

You can view the settings for a saved slide show.

To open a slide show:

1. From the **Start** menu, tap **Programs**.
2. Tap **Image Viewer**.
3. Tap **File**, then **Open Show Settings....**
4. Select the show setting.

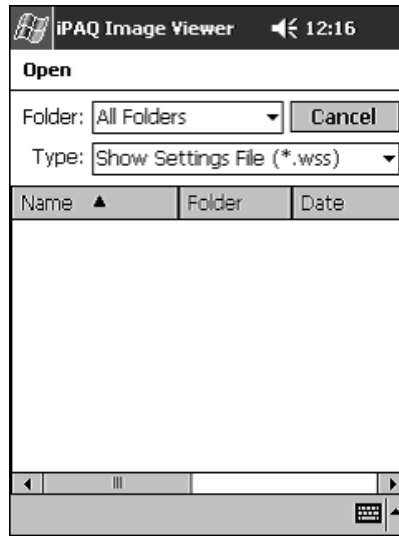

Sort Image Files

You can sort images in the show.

To sort image files:

1. From the **Start** menu, tap **Programs**.
2. Tap **iPAQ Image Viewer**.
3. Tap **Edit**, then **Sort Images**.
4. Select sort order. You can sort by ascending or descending **Name**, **Type**, **Size**, or **Date**.

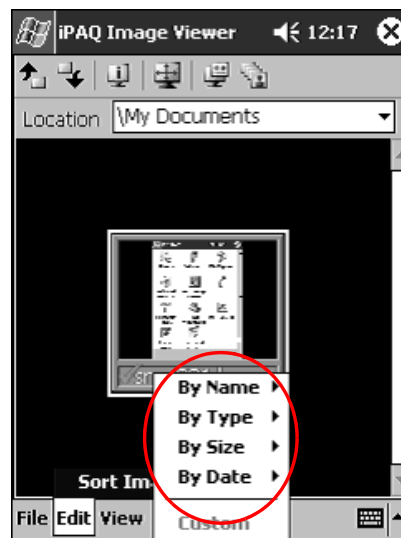

View Slide Show

1. From the **Start** menu, tap **Programs**.
2. Tap **Image Viewer**.
3. Create (see section “Create a Slide Show”) or open existing slide show (see section “Open a Slide Show”).
4. Tap **Show**, then **View Show**.

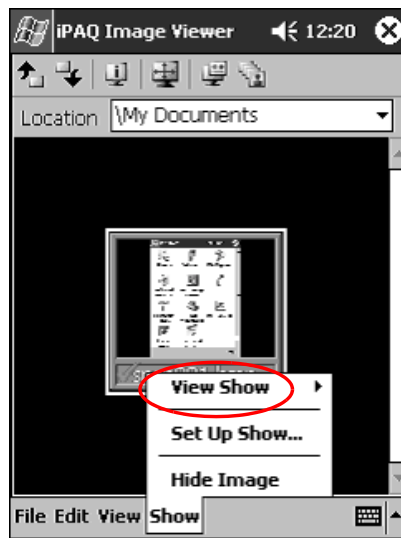

5. Select how to advance the images in the show. You can select **manual advance**, **automatic advance**, or **use a loop**.

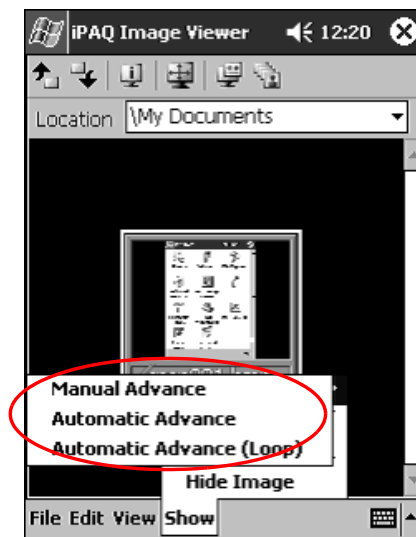

Using the Wireless LAN

Your HP iPAQ Pocket PC H5400 Series can connect to an 802.11b Wireless LAN (WLAN) or connect directly to other WLAN-enabled devices.

Learn the Terms

It is recommended that you become familiar with the following terms as you begin to use WLAN technology.

| Term | Definition |
|-----------------------|--|
| Profile | A collection of defined WLAN settings. |
| Wireless Access Point | The access point provides a wireless connection to a network (additional hardware). |
| Infrastructure | This connection mode uses wireless access points to connect to networks. |
| Ad hoc | This mode does not use access points. It is used in peer-to-peer network communications. All peers must be configured on the same channel. |

(Continued)

| Term | Definition |
|------------------|--|
| Hot spots | Public or private areas where there is a wireless access point available. |
| SSID | This is the acronym for the service set identifier. This identification number uses a maximum number of 32 characters and is case sensitive. |
| Encryption (WEP) | A set of security services used to protect 802.11 networks from unauthorized access. |

Get Acquainted

With WLAN, you can:

- Access the Internet
- Send and receive e-mail
- Access corporate network information
- Use virtual private networks (VPN) for secure remote access
- Use hotspots for wireless connectivity



Use of dial-up and wireless Internet, e-mail, corporate networks, and other wireless communications, such as Bluetooth-enabled devices, may require separately purchased additional hardware and other compatible equipment, in addition to a standard Wireless LAN (WLAN) infrastructure and a separately purchased service contract. Check with your service provider for availability and coverage in your area. Not all web content may be available. Some web content may require installation of additional software.

To use WLAN on your iPAQ Pocket PC, you need to turn ON the WLAN and set up your device.



The first time you tap the **iPAQ WLAN** icon, the **Setup** screen displays. Once you create profiles, tapping the **iPAQ WLAN** icon enables the WLAN and places the icon in the lower right corner of the **Today** screen.

Turn ON the WLAN

1. From the **Start** menu, tap **iPAQ WLAN**.
-



If you are setting your iPAQ Pocket PC for the first time, the **Setup** screen displays when you tap the **iPAQ WLAN** icon. Once you create profiles (see “Work with Profiles”), tapping the **iPAQ WLAN** icon enables the WLAN and places the icon in the lower right corner of the **Today** screen.

2. Tap the **WLAN** icon to turn on the WLAN.

The iPAQ Pocket PC has an LED indicator that illuminates to reflect WLAN and the connection status.

| If the LED indicator is... | Then, the WLAN is... |
|-----------------------------------|-----------------------------|
|-----------------------------------|-----------------------------|

Green

On and connected.

Yellow

On and not connected.

Work with Profiles

You must create profiles with or without security to use on your WLAN. You can view existing profiles to:

- Select for use
- Edit connection information
- Delete
- View connection status

Create Profiles without Security

1. Tap the **iPAQ WLAN** icon in the lower right corner of the **Today** screen.

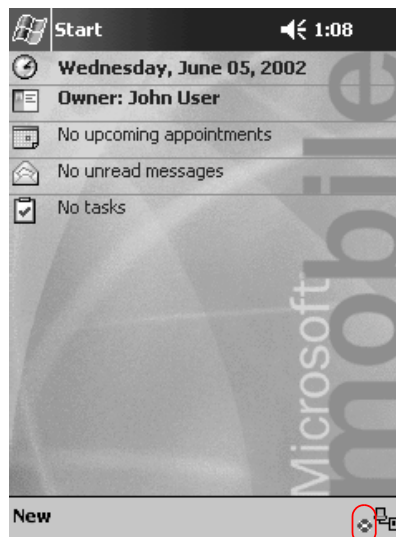

2. Tap **Setup**.

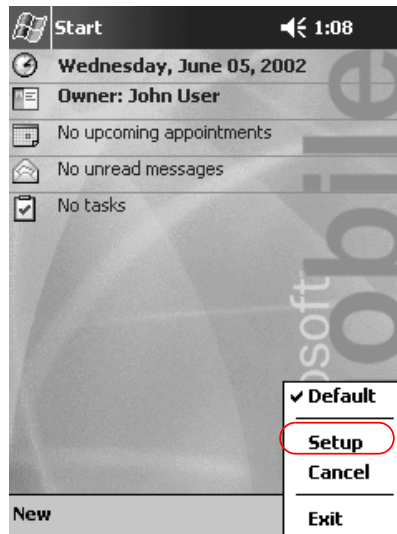

3. Tap the **New** button.

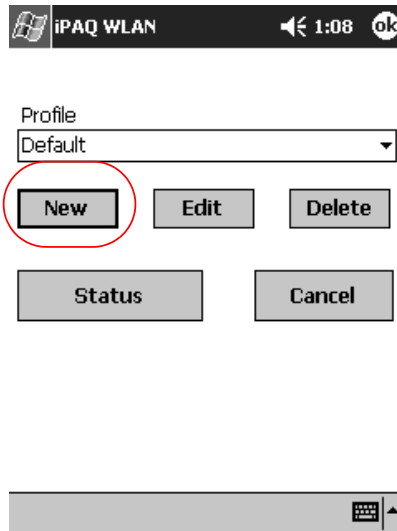

4. Enter the profile information.

| Field Name | Information |
|-------------------|--|
| Profile Name | Enter a name for your profile. |
| SSID | This is the service set identifier (SSID) and the default is "blank" when connecting to an infrastructure network. This allows you to connect to any available access point. You and the wireless site you want to connect to must use the same SSID. This identification number uses a maximum of 32 characters and is case sensitive. |
| Power Management | The default selection is "No." Selecting "Yes" will provide lower performance and use less power. |
| Network | You have two choices: infrastructure or ad hoc. The default selection is "Infrastructure." Use infrastructure to connect to a wired network via a wireless access point. Use ad hoc for peer-to-peer communications. |
| Channel | The default is "Auto." You do not need to specify a channel if you are using an infrastructure network. It will use the same channel as the access point. Otherwise, set the frequency that corresponds to your country's regulatory commission's range and the 802.11b standard. |
| Transmission Rate | The default is "Auto." This is the wireless data transmission speed. You can select speeds of 1, 2, 5.5, or 11 Mbps. |

5. Tap **Next**.

6. Tap "Use server-assigned IP address" and use the DHCP server address or select "Use specific IP address."

7. If you selected “Use specific IP address,” you must enter information in all remaining fields.



Please contact your network administrator or your service provider for this information.

8. Tap **Finish**.

Create Profiles with Security

You can use encryption to increase security to prevent data theft. This device supports open system (no encryption), 64-bit shared key, and 128-bit shared key encryption.

The wireless access point that you are connecting to must use the same encryption to receive and transmit data.

To create profiles with security:

1. Follow steps 1 through 6 in the section “Create Profiles without Security.”
2. Tap **Next**.
3. Select “64” or “128” bit from the **Wireless Encryption** down arrow list.
4. Select “hexadecimal” or “alphanumeric” from the **WEP Keys** down arrow list.

5. Enter valid key values.



The encryption key is case sensitive. Valid values for hexadecimal keys are “0–9 and A–F.” Valid values for alphanumeric keys are “0–9, a–z, and A–Z.”

The length of the key depends on whether a 64 bit (uses 5 alphanumeric or 10 hexadecimal values) or 128 bit (uses 13 alphanumeric or 26 hexadecimal values) wireless encryption mode was selected.

6. Tap **Finish**.

Close the WLAN Application

1. Tap the **iPAQ WLAN** icon in the lower right corner of the **Today** screen.
2. Tap **Exit** on the pop-up menu.

View Existing Profiles

Tap the **iPAQ WLAN** icon in the lower right corner of the **Today** screen.



Existing profiles are listed in the top section of the pop-up menu. The active profile is indicated by a check mark.

Select an Existing Profile

1. Tap the **iPAQ WLAN** icon in the lower right corner of the **Today** screen.
2. Tap a profile name from the list in the top section of the pop-up menu. The profile is automatically loaded.

Edit an Existing Profile

1. Tap the **iPAQ WLAN** icon in the lower right corner of the **Today** screen.
2. Tap **Setup**.
3. Select an existing profile from the **Profile** down arrow list to edit.
4. Tap the **Edit** button.

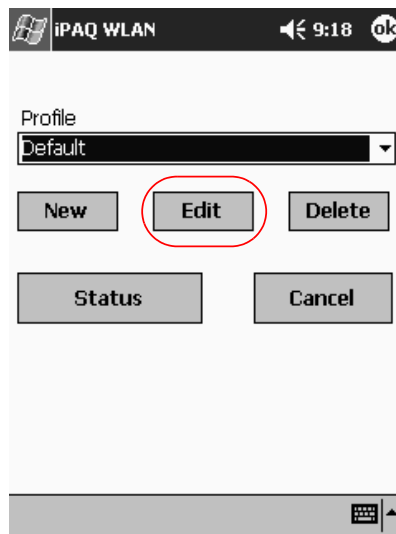

5. Make desired changes to the profile.
6. Tap **OK** to save the changes.

Delete a Profile

1. Tap the **iPAQ WLAN** icon in the lower right corner of the **Today** screen.
2. Tap **Setup**.
3. Select a profile from the **Profile** down arrow list.
4. Tap the **Delete** button.
5. Tap **Yes** to confirm.

Monitor Signal Strength and Status

You can monitor the strength and status of your connection by viewing the:

- **WLAN** icon on the **Today** screen
- Signal strength indicator on the **iPAQ WLAN** screen
- Signal strength indicator in the **Status** option

View Radio Signal Strength

You can view the strength of the radio signal from your iPAQ Pocket PC to the access point.

1. Tap the **iPAQ WLAN** icon in the lower right corner of the **Today** screen.
2. Tap **Setup** on the pop-up menu.
3. Notice the strength of the received signal and connection quality as indicated by the color coding and percentage value.
4. Tap **OK** to exit.

View WLAN Status

1. Tap the **iPAQ WLAN** icon in the lower right corner of the **Today** screen.
2. Tap **Setup**, then the **Status** button.



Tap the **Refresh** button to update the status.

Locate and Link to Wireless Sites

You can search for wireless sites within your radio coverage area and once located establish links.

Search for Wireless Sites

1. Tap the **iPAQ WLAN** icon in the lower right corner of the **Today** screen, then tap **Setup**.
2. Tap the **Status** button.
3. Tap the **Advanced** button, then tap the **Rescan** button to begin the search.
4. Tap **OK**.

Link to a Wireless Site

1. Tap the **iPAQ WLAN** icon in the lower right corner of the **Today** screen, then tap **Setup**.
2. Tap the **Status** button.
3. Tap the **Advanced** button.
4. Select a site from the **Wireless Sites** down arrow list.



Groups are organized based on the server set identifier (SSID) information.

5. Tap **OK**.

Recommended Uses

This product emits radio frequency energy, but the radiated output power of this device is far below the FCC radio frequency exposure limits. Nevertheless, the device should be used in such a manner that the potential for human contact with the antenna during normal operation is minimized.

Channel Settings

| Country | Channels Supported |
|----------------|---------------------------|
| US | CH 1~11 |
| Canada | CH 1~11 |
| Argentina | 1-13 |
| Bolivia | 1-13 |
| Brazil | 1-13 |
| Chile | 1-13 |
| Columbia | 1-13 |
| Ecuador | 1-13 |
| Mexico | 1-13 |
| Panama | 1-13 |
| Peru | 1-13 |
| Uruguay | 1-13 |
| Venezuela | 1-13 |
| Australia | 1-13 |
| Hong Kong | 1-13 |
| India | 1-13 |
| Indonesia | 1-13 |

Channel Settings *(Continued)*

| Country | Channels Supported |
|----------------|---------------------------|
| Japan | 1-14 |
| Korea | 1-13 |
| Malaysia | 1-13 |
| New Zealand | 1-13 |
| PRC | 1-13 |
| Philippines | 1-13 |
| Singapore | 1-13 |
| Taiwan | 1-13 |
| Thailand | 1-13 |
| Vietnam | 1-13 |
| | |
| Austria | 1-13 |
| Belgium | 1-13 |
| Bulgaria | 1-13 |
| Cyprus | 1-13 |
| Czech Republic | 1-13 |
| Denmark | 1-13 |
| Estonia | 1-13 |
| Finland | 1-13 |
| France | 10-13 |
| Germany | 1-13 |
| Greece | 1-13 |
| Hungary | 1-13 |
| Iceland | 1-13 |
| Ireland | 1-13 |

Channel Settings *(Continued)*

| Country | Channels Supported |
|-----------------|---------------------------|
| Israel | 5-7 |
| Italy | 1-13 |
| Liechtenstein | 1-13 |
| Luxembourg | 1-13 |
| Netherlands | 1-13 |
| Norway | 1-13 |
| Poland | 1-13 |
| Portugal | 1-13 |
| Russia | 1-13 |
| Slovak Republic | 1-13 |
| Slovenia | 1-13 |
| South Africa | 1-13 |
| Spain | 1-13 |
| Sweden | 1-13 |
| Switzerland | 1-13 |
| Turkey | 1-13 |
| United Kingdom | 1-13 |

Using Bluetooth

Your HP iPAQ Pocket PC is equipped with built-in Bluetooth technology that allows short-range connections and provides fast, reliable, and secure wireless communication.

With Bluetooth, you can perform the following tasks between two Bluetooth devices, within range, without a physical connection:

- Exchange contacts, calendar items, and tasks
- Send or exchange business cards
- Transfer files
- Access dial-up networks
- Synchronize with a computer
- Connect to serial ports
- Connect to Bluetooth wireless local area networks (WLANs)
- Use of Bluetooth headset
- Print to a Bluetooth printer

- Conduct a phone conversation using a Bluetooth headset
- Create a personal area network (PAN) to chat, play games, etc.

Use of dial-up networks and WLANs may require separately purchased additional hardware and compatible equipment, in addition to a standard WLAN infrastructure and a separately purchased service contract.



Use of dial-up and wireless Internet, e-mail, corporate networks, and other wireless communications, such as Bluetooth-enabled devices, may require separately purchased additional hardware and other compatible equipment, in addition to a standard Wireless LAN (WLAN) infrastructure and a separately purchased service contract. Check with your service provider for availability and coverage in your area. Not all web content may be available. Some web content may require installation of additional software.

Get Acquainted with Bluetooth

Before you start using Bluetooth to establish wireless connections, you should take a few minutes and familiarize yourself with the:

- Terms used in this booklet
- Supported services
- Bluetooth settings
- Bluetooth Manager

Understand Terms

There are several terms used throughout this booklet.

| The Term... | Means... |
|--|---|
| Authentication | The user must verify a numeric passkey before a connection or activity can be completed. |
| Authorization | The user must approve a connection or activity before it can be completed. |
| Bluetooth neighborhood or device group | A collection of Bluetooth devices. |
| Bonding (Paired devices) | To create a trusted connection between your device and another. Once a bond is created, the two devices become paired. A trusted device does not require authentication or authorization. |
| Device address | The unique electronic address of a Bluetooth device. |
| Device discovery | The location and recognition of another Bluetooth device. |
| Device name | The name a Bluetooth device provides when discovered by another device. |
| Encryption | A method of protecting data. |
| Link key | A key used to securely pair devices. |
| Passkey | A code you enter to authenticate connections or activities requested by other devices. |
| Personal Information Manager (PIM) | A collection of applications used to manage daily business tasks (e.g., Contacts, Calendar, and Tasks). |
| Profiles | A collection of Bluetooth settings. |
| Service discovery | Determining which applications you have in common with other devices. |

Review Supported Services

The functions that Bluetooth supports are called services. You can only communicate with Bluetooth devices that support the following services:

- Serial Port (COM port)
- LAN Access
- Dial-up Networking
- Information Exchange
- File Transfer
- Headset
- Print
- Personal area network (PAN)

Work with Bluetooth Settings

You can open **Bluetooth Settings** by tapping on the **Bluetooth** icon in lower-right corner of the **Today** screen.

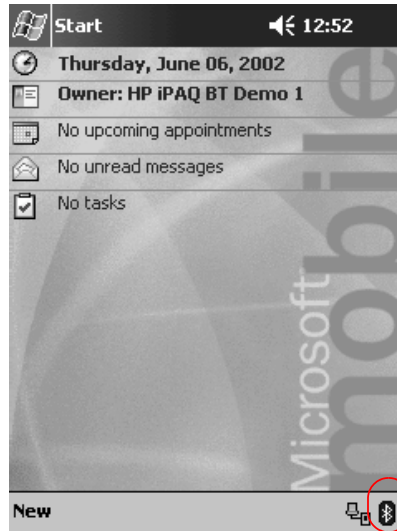

When the **Bluetooth** icon is blue, Bluetooth is active. When the icon is grayed with a red X, Bluetooth is inactive.

From the seven tabs in **Bluetooth Settings**, you can:

- Turn the hardware on and off
- Select a user profile
- Change your iPAQ Pocket PC Bluetooth name
- Specify security settings
- Define settings for sharing and connecting
- View software and port information

You must use the arrows to the right of the tab names to scroll through the tabs.

Open Bluetooth Settings

From the **Today** screen, tap the **Bluetooth** icon.

Turn ON Bluetooth

You can apply or remove power to the Bluetooth hardware from **Bluetooth Settings**.



To preserve battery power, it is recommended that you enable (turn on) Bluetooth only when using it.

When Bluetooth is off, no incoming or outgoing connections are possible.

To turn on Bluetooth:

1. From the **Today** screen, tap the **Bluetooth** icon.
2. Tap the **Turn on** button to enable.

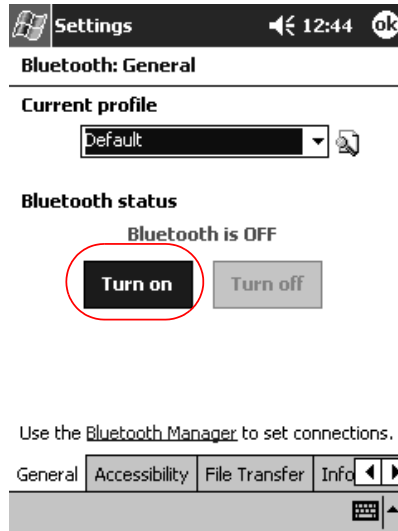

Tap the **Turn off** button to disable.

Work with the Bluetooth Manager

Using the Bluetooth Manager, you can:

- Establish connections
- Display shortcuts
- Exchange business cards
- Control the on-screen display

The first screen that displays is **My Shortcuts**.

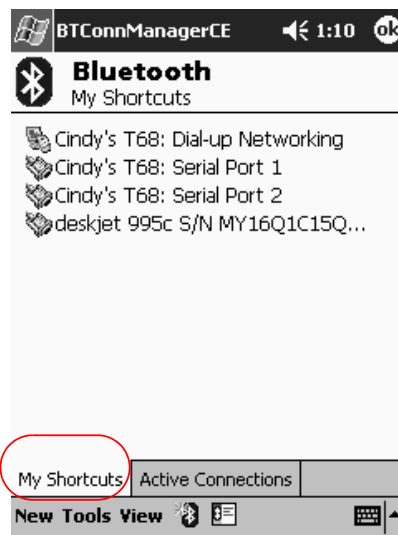

Open the Bluetooth Manager

1. On the **Today** screen, tap **Start**.
2. Tap **Programs**, then **Bluetooth Manager**.

Locate and Select a Device

Several tasks require you to locate a device and connect to it. When you are required to locate a device, the Bluetooth browser automatically assists by searching for other Bluetooth devices.

Once you locate a device, tap it to select. You will be returned to the previous window.

Understand Profiles

You can use profiles to quickly enable selected personal settings in multiple environments.

Create a Profile

A new profile does not automatically become active. You must select it from the **Current Profile** list to activate it.

To create a profile:

1. From the **Today** screen, tap the **Bluetooth** icon.
2. From the **General** tab, tap the **Profile** icon.

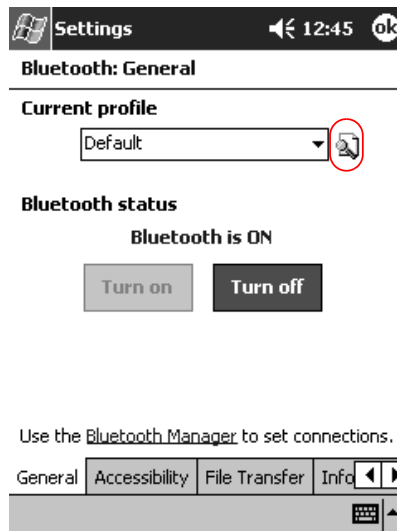

3. Tap the **New** button.
4. Enter a descriptive name.
5. Select an existing profile to use as a template.

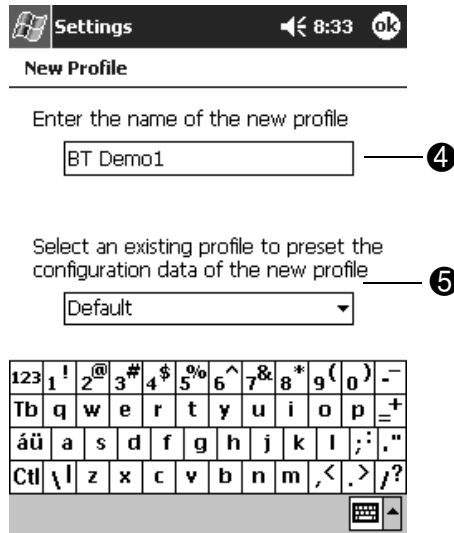

6. Tap **OK**.

Activate a Profile

You need to activate a new profile.

To activate a profile:

1. Create a profile.
2. From the **Today** screen, tap the **Bluetooth** icon.
3. From the **General** tab, select it from the **Current Profile** down arrow list.
4. Tap **OK**.

Rename a Profile

1. From the **Today** screen, tap the **Bluetooth** icon.
2. From the **General** tab, tap the **Profile** icon.
3. Select a profile from the **Add/Delete Profiles** list.
4. Tap the **Rename** button.
5. Enter a new descriptive name.
6. Tap **Enter**.
7. Tap **OK**.

Delete a Profile

1. From the **Today** screen, tap the **Bluetooth** icon.
2. From the **General** tab, tap the **Profile** icon.
3. Select a profile from the **Add/Delete Profiles** list.
4. Tap the **Delete** button.
5. Tap **Yes** to confirm you want to delete the profile.
6. Tap **OK**.

Save Configuration Settings in a Profile

You can save the iPAQ Pocket PC's Bluetooth configuration settings to any profile.

To save configuration settings:

1. From the **Today** screen, tap the **Bluetooth** icon.
2. From the **General** tab, tap the **Profile** icon.

3. Select a profile from the **Add/Delete Profiles** list or create a new one.
4. Tap **OK**.
5. Set up your iPAQ Pocket PC. You should specify the desired connection, sharing, and security settings in all Bluetooth **Settings** tabs.
6. Tap **OK** to close the Bluetooth **Settings**. The changes are automatically saved.



Bluetooth must be turned **on** for changes to be saved.

Set Accessibility Properties

You may want to enter or change accessibility properties to define how your iPAQ Pocket PC will interact with other Bluetooth devices.

Enter a Device Name

The device name is what other devices see when they locate your device.

To enter a device name:

1. From the **Today** screen, tap the **Bluetooth** icon.
2. Tap the **Accessibility** tab.
3. Highlight the name in the **Name** field and enter a new one.
4. Tap **OK** to save your changes.

Allow Others to Locate My Device

You can allow other devices to search and locate your iPAQ Pocket PC.



If another remote device has your device's address, that device may be able to locate and connect to you even though you did not select for your device to be discovered.

To allow others to locate my device:

1. From the **Today** screen, tap the **Bluetooth** icon.
2. Tap the **Accessibility** tab.
3. Select **Other devices can discover me**.
4. Tap **OK** to save the changes.

Pair Devices

You can pair devices so that they must exchange a computer generated key prior to each connection. The security key is also called a "Link Key." It is generated from a unique Bluetooth device address, a random number, and a user-defined password.

Once two devices are paired, they have a trusted relationship with each other that can be verified using a link key. No additional input is needed from the user. Therefore, connections and activities can be performed between the devices without constant authorization from the user.

To pair devices:

1. From the **Today** screen, tap **Start**.
2. Tap **Programs**, then **Bluetooth Manager**.
3. Tap **Tools**, then **Paired devices**.
4. Tap **Add**.

5. Tap the **Lookup**  icon.
6. Tap a device.



7. Enter a password in the **Passkey** field.
8. Tap **OK**.
9. Enter the same passkey into the other device.



Some devices, such as mobile phones, need to be placed in a mode to accept a bond from another device. Refer to that device's user instructions for more information.

Unpair Devices

You can remove the paired relationship between devices.

1. From the **Today** screen, tap **Start**.
2. Tap **Programs**, then **Bluetooth Manager**.
3. Tap **Tools**, then **Paired devices**.
4. Tap a device name.
5. Tap **Remove**.
6. Tap **Yes** to remove the pairing.

Allow Connecting

You can determine if all devices or only paired devices can connect to your iPAQ Pocket PC.

Allow All Devices to Connect

1. From the **Today** screen, tap the **Bluetooth** icon.
2. Tap the **Accessibility** tab.
3. Select **Allow other devices to connect**, then **All devices**.
4. Tap **OK**.



CAUTION: This allows any device, even those unknown to you, to connect to your iPAQ Pocket PC. Once they are connected, security settings for specific services will apply as specified in the Bluetooth Settings.

Allow Paired Devices to Connect

Paired devices share and exchange an internally generated Link Key prior to each connection. The Link Key is derived from a unique Bluetooth device address, a random number, and user-defined password.

This feature allows only devices that you trust to connect to your iPAQ Pocket PC.

To allow paired devices to connect:

1. From the **Today** screen, tap the **Bluetooth** icon.
2. Tap the **Accessibility** tab.
3. Select **Allow other devices to connect**, then **Paired devices only**.
4. Tap **OK**.

Enable Bluetooth Services

You can select to have certain services enabled:

- Automatically when Bluetooth is activated
- When you permit the connection
- When a passkey or link key is correctly entered

You can use any of these security options when transferring files, creating a serial port connection, exchanging business card information, and configuring dial-up networking.

Automatically Enable Services

You can allow devices to connect without any authorization. When Bluetooth is on, it is ready for connections.

To automatically enable services:

1. From the **Today** screen, tap the **Bluetooth** icon.
2. Tap the tab for the service you want to enable: **File Transfer, Information Exchange, Serial Port, Dial-up Networking, Printing, Headset, or Personal Area Networking (PAN)**.
3. Select **Enable service**.
4. Tap **OK**.

Require Authorization to Access Services

If you elect to require authorization to access services, you must authorize each connection. Your iPAQ Pocket PC will ask you if the connection should be permitted.

To require authorization to access services:

1. From the **Today** screen, tap the **Bluetooth** icon.
2. Tap the tab for the service you want to enable: **File Transfer, Information Exchange, Serial Port, Dial-up Networking, Printing, Headset, or PAN**.
3. Select **Authorization required**.
4. Tap **OK**.

Require a Passkey or Bond to Access Services

To establish a connection, the other device must have a passkey or an established bond for added security. You can add data encryption to this type of security.

A passkey is a code you enter to authenticate connections requested by other devices. The passkey must be known and used by both parties or the connection will not be allowed.

| If... | Then... |
|---|--|
| Both devices successfully enter the known passkey | A bond is created between the devices. You do not have to enter the passkey again to exchange information. |
| You want to require a passkey exchange each time you transmit information | You must remove the bond ("Unpair Devices") prior to establishing the connection. |

To require a passkey or bond:

1. From the **Today** screen, tap the **Bluetooth** icon.
2. Tap the tab for the service you want to enable: **File Transfer, Information Exchange, Serial Port, Dial-up Networking, Printing, Headset, or PAN**.
3. Select **Authentication (Passkey) required**.
4. Select **Encryption Required** if you want to require all data exchanged between the devices to be encrypted.
5. Tap **OK**.

Set Shared Folder

You can determine the folder that other devices can access when they connect to your iPAQ Pocket PC.

To set a shared folder:

1. From the **Today** screen, tap the **Bluetooth** icon.
2. Tap the **File Transfer** tab.
3. Tap the **Folder** icon and locate a desired file folder.

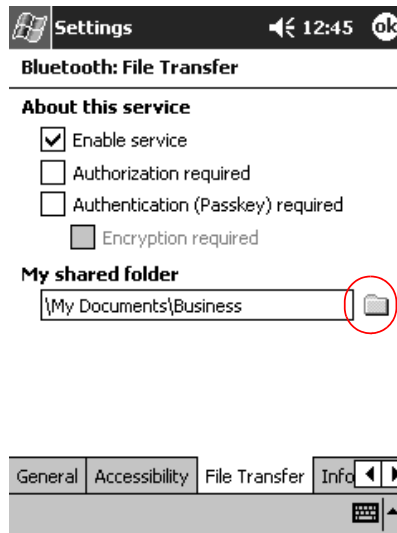

4. Tap **OK**.

Select Business Card Information

Two Bluetooth devices can exchange business card information electronically. You can determine the information about you that is sent to another device upon request. This information comes from the Contacts list in Pocket Outlook.

The default selection is “None.”

To select business card information:

1. Create a contact in the **Contacts** application that includes your name, title, and other relevant information.
2. From the **Today** screen, tap the **Bluetooth** icon.
3. Tap the **Information Exchange** tab.
4. Tap the **Contacts** icon.

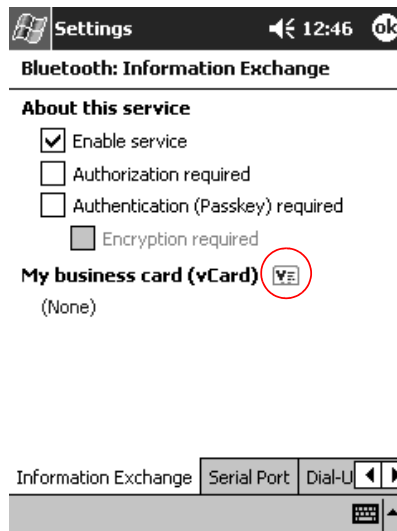

5. Choose your contact from the list.
6. Tap **OK**.

Connect to Other Devices

You can use serial and dial-up connections to communicate with other Bluetooth devices.

Identify the Communications Port

You can identify the virtual COM ports used to create a **serial port** connection. You may need to identify these COM ports for activities such as printing.

The inbound COM port is used when other devices initiate a serial connection. The outbound COM port is used when you initiate a serial connection to another device.

To identify the communications port:

1. From the **Today** screen, tap the **Bluetooth** icon.
2. Tap the **Serial Port** tab.
3. Note the names of your inbound and outbound COM ports.
4. Tap **OK**.

Establish a Serial Connection

You can use the wireless Bluetooth serial port connection just like you would a physical serial cable connection. You must configure the application that will use the connection to the correct serial port.

To establish a serial connection:

1. From the **Today** screen, tap **Start**.
2. Tap **Programs**, then **Bluetooth Manager**.
3. Tap **New**, then **Connect**.
4. Tap “Explore a Bluetooth device,” then tap **Next**.
5. Follow the connection wizard instructions.

Use Dial-Up Networking

When using dial-up networking, the remote device providing the dial-up networking service, and the remote computer to which you are connecting must both have telephone access.

Devices that can provide dial-up networking include Bluetooth:

- Mobile phones
- Desktop computers
- Modems

Configure Dial-Up Connections

You can configure the dial-up networking settings.

1. From the **Today** screen, tap the **Bluetooth** icon.
2. Tap the **Dial-Up Networking** tab.
3. Select a communications port from the **COM Port** down arrow list.
4. Select a baud rate from the **Baud Rate** down arrow list (typical rate is 57600).
5. Select the type of flow control to use from the **Flow Control** down arrow list (typical setting is hardware [RTS/CTS]).
6. Tap **OK**.

Use Dial-Up Networking

Connect to a device that provides telephone access.

1. From the **Today** screen, tap **Start**.
2. Tap **Programs**, then **Bluetooth Manager**.
3. Tap **New**, then **Connect**.
4. Tap “Connect to the Internet.” Then follow the connection wizard instructions.



Once you have created the dial-up networking shortcut with a device, tap and hold the shortcut icon in the **My Shortcuts** tab of the **Bluetooth Manager**, then tap **Connect**.

5. Tap **New Connection**.
6. Tap **OK**.
7. Enter a name in the **Connection Name** field.
8. Enter a phone number. You have to enter the country code and area code depending on where you are calling.
9. Tap **OK** to begin dialing.



Some mobile phones require a bond between device (see the section “Pair Devices”).

Work with Files

You can exchange information with a connected device. You can use the Bluetooth File Explorer to:

- Navigate through the directories
- View files and folders
- Create new folders
- Send and receive files from a remote device
- Delete and rename files on a remote device

Create a File Transfer Connection

1. From the **Today** screen, tap **Start**.
2. Tap **Programs**, then **Bluetooth Manager**.
3. Tap **New**, then **Connect**.
4. Tap “Browse files on a remote device,” then tap **Next**.
5. Follow the connection wizard instructions.

Send Files

1. Tap and hold a file transfer shortcut icon, then tap **Connect**.
2. Tap **File**, then Tap **Send a File....**
3. Locate a file to send.
4. Tap the file to automatically send it.
5. Tap **OK**.

Create a Folder on a Remote Device

1. Tap and hold a file transfer shortcut icon, then tap **Connect**.
2. Navigate to the location you want for the new folder.
3. Tap **File**, then **Create a folder**.
4. Enter a folder name while **New Folder** is highlighted, then tap **Enter**.
5. Tap **OK**.

Receive a File from a Remote Device

1. Tap and hold a file transfer shortcut icon, then tap **Connect**.
2. Navigate to the file location on the remote device.
3. Tap the file.
4. Tap **File**, then tap **Get**.
5. Tap **OK**.

Delete a File from a Remote Device

1. Tap and hold a file transfer shortcut icon, then tap **Connect**.
2. Navigate to the file location on the remote device.
3. Tap the file.
4. Tap **File**, then tap **Delete**.
5. Tap **Yes** to verify you want to delete the selected file.
6. Tap **OK**.

Send Information via Bluetooth

In Pocket Outlook, you can send contacts, calendar information, and tasks to a remote device using Bluetooth.

To send information using Bluetooth:

1. Open the Calendar, Contacts, or Tasks application from the **Start** menu or tap **Start**, then **Programs**.
2. Tap and hold the item to send, then select “Send via Bluetooth.”
3. Tap the name of destination device.
4. Tap **OK**.

Use Business Cards

Using the business card exchange, you can:

- Send a business card to one or more devices
- Request a business card from one or more devices
- Exchange business cards with one or more devices

You must establish a default contact name to send or exchange business card information.

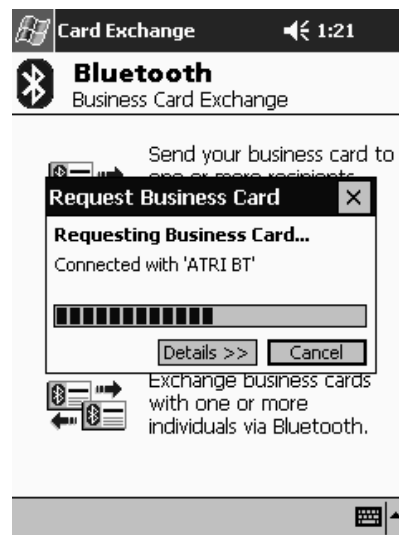

You must first specify your default business card on the Information Exchange tab in the Bluetooth Control Panel. This name becomes the default for business card transfers (“Identify the Communications Port”).

Send Business Card

1. From the **Today** screen, tap **Start**.
2. Tap **Programs**, then **Bluetooth Manager**.
3. Tap the **Business card** icon.



You can open the business card exchange by tapping **Tools**, **Business Card Exchange** in the **Bluetooth Manager**.

4. Tap the **Send** icon.
5. Tap the device where you want to send your business card.
6. Tap **OK**.

Request Business Cards

1. From the **Today** screen, tap **Start**.
2. Tap **Programs**, then **Bluetooth Manager**.
3. Tap the **Business card** icon.
4. Tap the **Request** icon.
5. Tap the device you want to request a business card.
6. Tap **OK**.

Exchange Business Card

You can exchange business card information with another device. If available, the device's information will be sent directly into your **Contacts** list in **Pocket Outlook**.

To exchange business cards:

1. From the **Today** screen, tap the **Windows** icon.
2. Tap **Programs**, then **Bluetooth Manager**.
3. Tap the **Business card** icon.
4. Tap the **Exchange** icon.
5. Tap the device where you want to exchange your business card.
6. Tap **OK**.

Work with Connections

You can create shortcuts to open and view status information for all connections.

Create a Shortcut

Creating a shortcut to one or more services does not establish a connection. It only places a shortcut to that service on the **Shortcut** tab of the **Bluetooth Manager**.

To create a shortcut:

1. From the **Today** screen, tap **Start**.
2. Tap **Programs**, then **Bluetooth Manager**.
3. Tap **New**, then **Connect**.
4. Select a type of service, then tap **Next**.
5. Follow the connection wizard instructions.



Paired devices are designated by a checkmark.

Delete a Shortcut

1. From the **Today** screen, tap **Start**.
2. Tap **Programs**, then **Bluetooth Manager**.
3. Tap and hold the connection icon or list name to be deleted.
4. Tap **Delete** from the menu.
5. Tap **Yes** to verify the selected shortcut should be deleted.
6. Tap **OK**.

View Shortcuts

You can view shortcuts as icons or in a list format.

1. From the **Today** screen, tap **Start**.
2. Tap **Programs**, then **Bluetooth Manager**.
3. Tap **View**.
4. Tap **List** or **Icon**.
5. Tap **OK**.

Open a Connection

1. From the **Today** screen, tap **Start**.
2. Tap **Programs**, then **Bluetooth Manager**.
3. Tap and hold the icon or list name, then tap **Connect**.
4. Tap **OK**.

View Connection Status

You can view:

- Connection's name
- Device's name
- Connection status
- Length of connection
- Signal strength

To view the connection status:

1. From the **Today** screen, tap **Start**.
2. Tap **Programs**, then **Bluetooth Manager**.
3. Tap and hold an active connection icon or list name, then tap **Status**.
4. Tap **OK**.

Close a Connection

1. From the **Today** screen, tap **Start**.
2. Tap **Programs**, then **Bluetooth Manager**.
3. Tap and hold the connection icon or list name.
4. Tap **Disconnect** from the menu.
5. Tap **OK**.

View Connection Information

1. From the **Today** screen, tap **Start**.
2. Tap **Programs**, then **Bluetooth Manager**.
3. Tap and hold the connection icon or list name.
4. Tap **Properties** from the menu.
5. Tap **OK**.

Using the Fingerprint Reader

You can increase the security of the data stored in your iPAQ Pocket PC by using the iPAQ Fingerprint Reader. This feature allows you to require a PIN, password, and/or fingerprint be entered before you can log on to your iPAQ Pocket PC.



WARNING: In the event that an incorrect or unsuccessful PIN, password, and/or fingerprint is repeatedly or incorrectly entered, all data and applications stored in RAM are erased and the iPAQ Pocket PC is returned to the as-shipped configuration. It is recommended that you back up all data frequently when using the security features.

It is recommended that you complete the fingerprint reader training on your iPAQ Pocket PC prior to changing your security settings.

Learn to Enroll a Fingerprint

Fingerprint Reader enrollment training is available on the iPAQ Pocket PC to assist you in proper enrollment of your unique fingerprint. You can access the training in two ways:

- First time you open a **Fingerprint** screen
- Tap the **Training** button from 1 of the logon setup fingerprint screens

To learn to enroll fingerprints:



You can tap **OK** at the top of the screen at anytime to exit the training.

1. From the **Start** menu, tap **Settings**, then **Password**.
2. Select **PIN** or **fingerprint** from the down arrow list to access training.

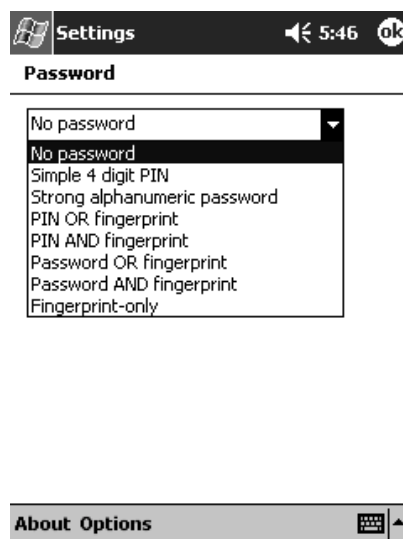

3. Tap 4 digits in the **PIN** field.

4. Tap **OK** or **ENTR**.

5. Tap **Yes** to begin **Fingerprint Reader** training.

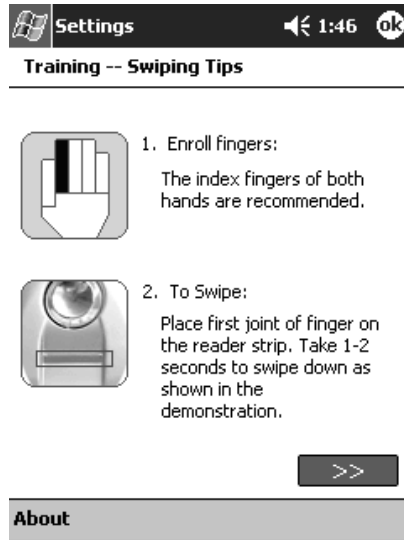

6. Read the swiping tips.

7. Tap the **double arrows** button.

8. Follow the on-screen demonstration to swipe a finger.



 If the finger swipe is acceptable, the oval frame turns green and the message “Good! Please continue” displays. If the finger swipe is unacceptable, the oval frame turns red and the message “Poor quality. Try again!” displays.

9. Repeat the finger swiping exercise as prompted until you have completed 6 out of 8 successful swipes.

 You must perform 6 acceptable swipes to continue the training.

10. Tap the **double arrows** button to continue the Self-test.

11. Perform 8 finger swipes in the Self-test.

 You must perform 7 acceptable swipes to complete the training.

12. Tap **Finish** to end the training.
13. Tap **OK** to exit or tap a finger to enroll.

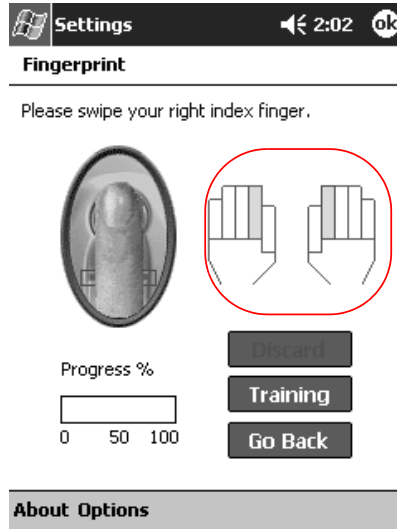

Work with Fingerprints

iPAQ Fingerprint Reader suggests fingers for you to use during the swiping activity. You can select a different finger at any time.

It is recommended that you enroll at least 2 fingers (index fingers are suggested). To enroll a fingerprint, you must take between 2 and 8 quality finger swipes.

Enroll a Fingerprint

The **Fingerprint** screen uses color coding to display the status of your fingerprint swipe.

Fingerprint Status

| If the color around the oval is... | Then... |
|---|---|
| Blue | No fingerprint has been taken for the finger. |
| Green | The fingerprint swipe was good quality. |
| Red | The fingerprint swipe was poor quality. |

To enroll a fingerprint:

1. From the **Start** menu, tap **Settings**, then **Password**.
2. Select the option from the down arrow list that you choose for your security setting.

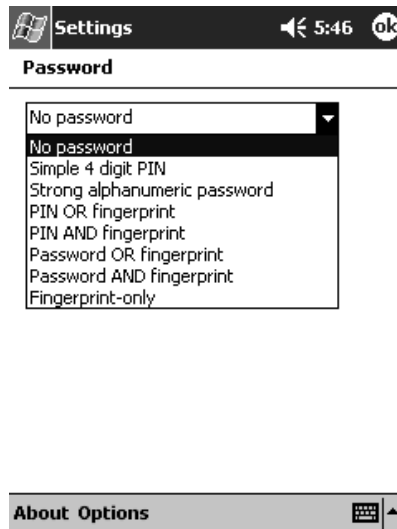

3. Enter either your PIN or password when prompted.

4. On the **Fingerprint** screen, tap the finger on the display you want to enroll.
5. Swipe the selected finger as instructed.



It is recommended that you gently swipe your finger downward across the sensor. You should begin the swipe at the first joint of your finger and continue downward with a smooth slow motion.

If you need additional assistance at any time, tap the **Training** button.

6. Monitor the status to see if your fingerprint was correctly swiped.



If OK, the perimeter of the oval turns green and a message displays indicating the quality was good. If poor quality, the perimeter of the oval turns red and a message displays.

- Repeat steps 5 and 6 to acquire a sufficient number of quality swipes (notice the progress bar) to enroll the print.



- Tap **OK**.

- Tap **Yes**.

Delete a Fingerprint

You can delete any saved fingerprints.

1. From the **Start** menu, tap **Settings**, then **Password**.
2. Tap the finger you want to delete, then tap **Discard**.

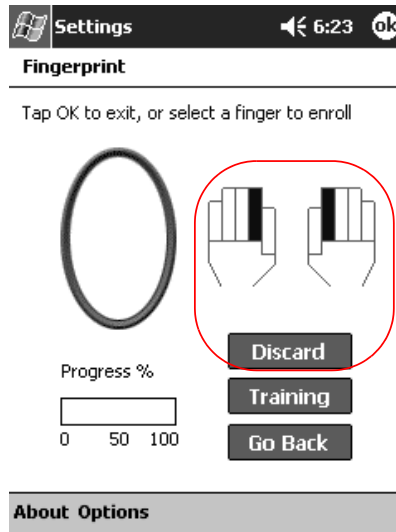

3. Tap **Yes** to confirm the deletion.

Set Logon Passwords

You have a variety of options for setting logon passwords. You can select:

- No password (default)
- 4-digit PIN
- PIN or fingerprint
- PIN and fingerprint
- Alphanumeric password
- Alphanumeric password or fingerprint
- Alphanumeric password and fingerprint
- Fingerprint only

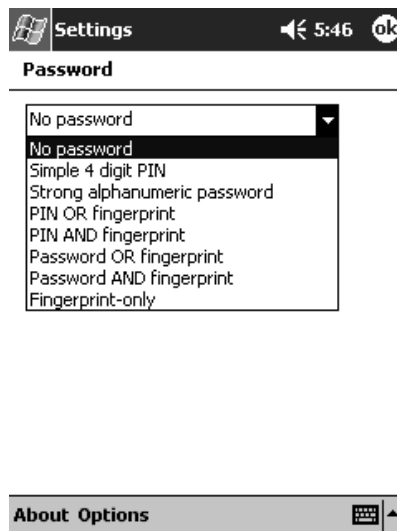

If you are using ActiveSync, you must enter a password on your personal computer to begin synchronization.

Set “No password” for Logon

In this mode, you are not required to enter a PIN, password, or fingerprint to logon.

1. From the **Start** menu, tap **Settings**, then **Password**.
2. Select “No password” from the down arrow list.
3. Tap **OK**.
4. Tap **Yes** to save the changes.



WARNING: In the event that an incorrect or unsuccessful PIN, password, and/or fingerprint is repeatedly or incorrectly entered, all data and applications stored in RAM are erased and the iPAQ Pocket PC is returned to the as-shipped configuration. It is recommended that you back up all data frequently when using the security features.

Set “Simple 4 digit PIN” for Logon

In this mode, you are required to enter a 4-digit PIN to logon.

1. From the **Start** menu, tap **Settings**, then **Password**.
2. Select “Simple 4 digit PIN” from the down arrow list.
3. Select from the down arrow list the length of time the iPAQ Pocket PC can remain unused before you must reenter the PIN.

4. Tap 4 digits in the **PIN** field.

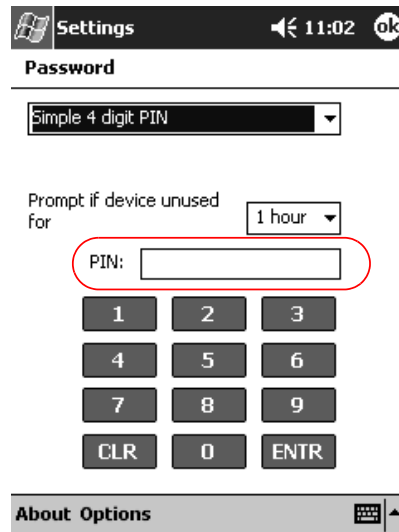

5. Tap **OK** or **ENTR**.
6. Tap **Yes** to save the changes.

Set “Strong alphanumeric password” for Logon

In this mode, you are required to enter a strong password with at least 7 characters to logon. This password must contain a combination of upper and lowercase letters, numerals, or punctuation.

1. From the **Start** menu, tap **Settings**, then **Password**.
2. Select “Strong alphanumeric password” from the down arrow list.
3. Select from the down arrow list the length of time the iPAQ Pocket PC can remain unused before you must reenter the password.

4. Enter 7 alphanumeric characters in the **Password** field.



Your password must have at least 7 characters and contain both upper and lower case letters and numbers. You can use punctuation marks.

5. Repeat step 4 in the **Confirm** field.
6. Tap **OK**.
7. Tap **Yes** to save.

Set “PIN OR fingerprint” for Logon

In this mode, you are required to enter a 4-digit PIN or fingerprint to logon.

1. From the **Start** menu, tap **Settings**, then **Password**.
2. Select “PIN OR fingerprint” from the down arrow list.
3. Tap 4 digits in the **PIN** field.
4. Select from the down arrow list the length of time the iPAQ Pocket PC can remain unused before you must reenter the PIN.
5. Tap **OK** or **ENTR**.
6. Tap the finger to enroll.
7. Swipe the selected finger as instructed.



For more information on finger swiping, see the section “Enroll a Fingerprint” or tap the **Training** button.

8. Tap **OK**.
9. Tap **Yes** to save changes.

Set “Password OR fingerprint” for logon

In this mode, you are required to enter an alphanumeric password with at least 7 characters or a fingerprint to logon.



The alphanumeric password must contain a combination of upper and lower case letters, numbers, and punctuation.

1. From the **Start** menu, tap **Settings**, then **Password**.
2. Select “Password OR fingerprint” from the down arrow list.
3. Select from the down arrow list the length of time the iPAQ Pocket PC can remain unused before you must reenter the password.
4. Enter 7 alphanumeric characters in the **Password** field.
5. Repeat step 4 in the **Confirm** field.
6. Tap **OK**.
7. Tap the finger to enroll.
8. Swipe the selected finger as instructed.



For more information on finger swiping, see the section “Enroll a Finger print” or tap the **Training** button.

9. Tap **OK**.
10. Tap **Yes** to save changes.

Set “PIN AND fingerprint” for Logon

In this mode, you are required to enter both a PIN and a fingerprint to logon.

1. From the **Start** menu, tap **Settings**, then **Password**.
2. Select “PIN AND fingerprint” from down arrow list.

3. Select from the down arrow list the length of time the iPAQ Pocket PC can remain unused before you must reenter the PIN.
4. Tap 4 digits in the **PIN** field.
5. Tap **OK** or **ENTR**.
6. Tap the finger to enroll.
7. Swipe the selected finger as instructed.



For more information on finger swiping, see the section “Enroll a fingerprint” or tap the **Training** button.

8. Tap **OK**.
9. Tap **Yes** to save changes.

Set “Password AND Fingerprint” for Logon

In this mode, you are required to enter both a password with at least 7 characters and a fingerprint to logon.



The alphanumeric password must contain a combination of upper and lower case letters, numbers, and punctuation.

1. From the **Start** menu, tap **Settings**, then **Password**.
2. Select “Password AND fingerprint” from down arrow list.
3. Select from the down arrow list the length of time the iPAQ Pocket PC can remain unused before you must reenter the password.
4. Enter 7 alphanumeric characters in the **Password** field.
5. Repeat step 4 in the **Confirm** field.
6. Tap **OK**.

7. Tap the finger to enroll.
8. Swipe the selected finger as instructed.



For more information on finger swiping, see the section “Enroll a fingerprint” or tap the **Training** button.

9. Tap **OK**.
10. Tap **Yes** to save changes.

Set “Fingerprint-only” for Logon

In this mode, you are required to enter a successful fingerprint to logon.



WARNING: In the event that an incorrect or unsuccessful fingerprint is repeatedly or incorrectly entered, all data and applications stored in RAM are erased and the iPAQ Pocket PC is returned to the as-shipped configuration. It is recommended that you back up all data frequently when using the security features.

1. From the **Start** menu, tap **Settings**, then **Password**.
2. Select “fingerprint-only” from the down arrow list.



If you are using ActiveSync, you must enter a password on your personal computer to begin synchronization.

3. Tap the finger to enroll.
4. Swipe the selected finger as instructed.



For more information on finger swiping, see the section “Enroll a Fingerprint” or tap the **Training** button.

5. Tap **OK**.
6. Tap **Yes** to save changes.

Logon Using PIN, Passwords, and Fingerprints

If you have set up a PIN, password, and/or fingerprint for logon, you must enter the correct PIN, password, and/or successfully swipe the correct fingerprint to use your iPAQ Pocket PC.

When you power on your iPAQ Pocket PC, you will be required to enter your logon information on the **PIN, Password** and/or **Fingerprint** screen.



WARNING: In the event that an incorrect or unsuccessful PIN, password, and/or fingerprint is repeatedly or incorrectly entered, all data and applications stored in RAM are erased and the iPAQ Pocket PC is returned to the as-shipped configuration. It is recommended that you back up all data frequently when using the security features. The default number of attempts is 6. You can select the maximum number of attempts.

Logon with No Password

You do not need to enter a password or fingerprint to use the iPAQ Pocket PC.

Logon Using a 4-digit PIN

You must enter the 4-digit PIN you entered during setup.

1. Turn on your iPAQ Pocket PC.
2. Tap your 4-digit PIN.
3. Tap **OK** or **ENTR**.

Logon Using a Password

You must enter the alphanumeric password you entered during setup.

1. Turn on your iPAQ Pocket PC.
2. Enter your password.
3. Tap **OK** or **ENTR**.

Logon Using a PIN or Fingerprint

You must enter a PIN or swipe the fingerprint you entered during setup. iPAQ Fingerprint Reader remembers your logon preference.

The next time you logon, the **PIN** or **Fingerprint** window corresponding to your last logon will be displayed.

1. Turn on your iPAQ Pocket PC.
2. Enter your 4-digit PIN or tap the **Fingerprint** tab to swipe your enrolled finger.



If your fingerprint was of poor quality, iPAQ Fingerprint Reader will ask you to swipe it again. If the quality was good, but there was not a match, the message “No match” will be displayed.

Logon Using a PIN and Fingerprint

You must enter both a PIN and swipe the fingerprint you entered during setup.

1. Turn on your iPAQ Pocket PC.
2. Enter your 4-digit PIN.
3. Swipe your enrolled finger.

Logon Using a Password or Fingerprint

You must enter a password or swipe the fingerprint you entered during setup.

1. Turn on your iPAQ Pocket PC.
2. Enter your password or swipe your enrolled finger.



To type letters, numbers, or punctuation, tap the **Keyboard** button at the bottom right corner of the screen. If you do not enter the correct password, you will be prompted to try again.

3. Swipe your fingerprint if you did not enter your password.

Logon Using a Password and Fingerprint

You must enter both a password and swipe the fingerprint you entered during setup. iPAQ Fingerprint Reader remembers your logon preference.

The next time you logon, the **Password** or **Fingerprint** screen corresponding to your last logon will be displayed.

1. Turn on your iPAQ Pocket PC.
2. Enter your password.



If you do not enter the correct password, you will be prompted to try again.

3. Tap **OK**.
4. Swipe your enrolled finger.

Logon Using a Fingerprint Only

You must successfully swipe the fingerprint you entered during setup.



WARNING: In the event that an incorrect or unsuccessful fingerprint is repeatedly or incorrectly entered, all data and applications stored in RAM are erased and the iPAQ Pocket PC is returned to the as-shipped configuration. It is recommended that you back up all data frequently when using the security features. The default number of attempts is 6. You can select the maximum number of attempts for your security needs.

1. Turn on your iPAQ Pocket PC.
2. Swipe your enrolled finger.

Set Security Options

You can set the Fingerprint Reader security on your iPAQ Pocket PC to 1 of 3 levels:

- Regular (default)
- High
- Extra High

It is recommended that you use the **Regular** security setting.

You can set the maximum number of attempts allowed for logging on to your iPAQ Pocket PC.



WARNING: In the event that an incorrect or unsuccessful PIN, password, and/or fingerprint is repeatedly or incorrectly entered, all data and applications stored in RAM are erased and the iPAQ Pocket PC is returned to the as-shipped configuration. It is recommended that you back up all data frequently when using the security features.

Set the Security Level

1. From the **Start** menu, tap **Settings**, then **Password**.
2. In the **Fingerprint** screen, tap **Options**.
3. Select your preferred security level.

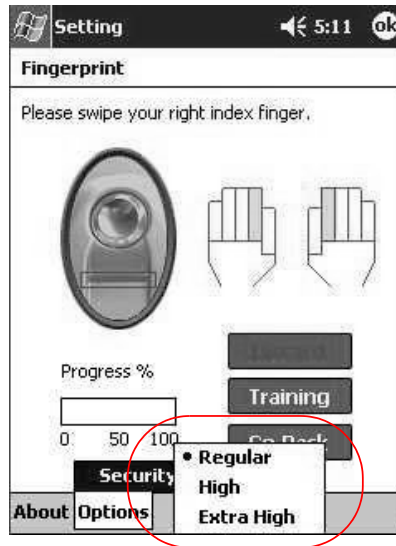

4. Tap **OK**.

Set the Maximum Number of Attempts

It is important to consider the maximum number of attempts. If you unsuccessfully enter your PIN, password, or fingerprint the maximum number of attempts, you will lose all data and applications in the RAM and your iPAQ Pocket PC will be returned to an as-shipped configuration.

1. From the **Start** menu, tap **Settings**, then **Password**.

- When using a PIN or password, tap **Options**, then **Max Logon Attempts**.

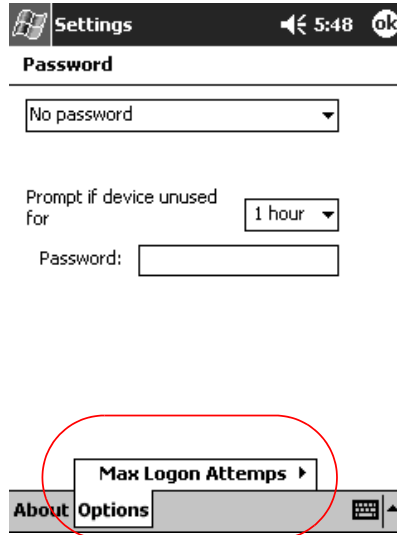

- Select the maximum number of attempts.

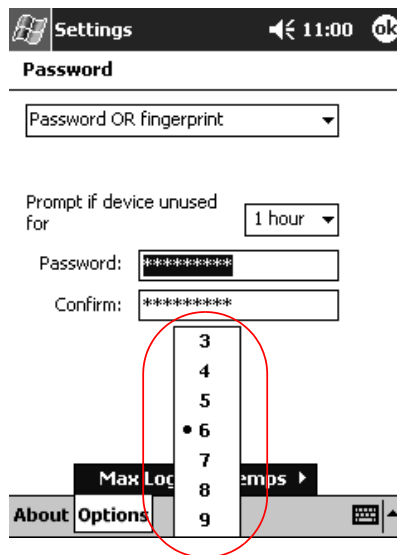

- Tap **OK**.

Connecting

Your iPAQ Pocket PC h5400 Series lets you connect in many ways:

- Connect to a computer
- Connect to the Internet or your network



You can use the Microsoft Pocket PC Connection Wizard to help you set up connection preferences. The wizard is located on the companion CD or at <http://www.pocketpc.com>.

The wizard installs on your personal computer desktop and guides through the set up process for several different types of connections (for example, modem, Virtual Private Network, and cell phone) and configurations (for example, e-mail and instant messaging). The connection and configuration information are automatically sent from your personal computer to your iPAQ Pocket PC.

Connect to a Computer

You can wirelessly connect to your personal computer using an infrared connection, Bluetooth, or wireless LAN.

You can physically connect your iPAQ Pocket PC to your personal computer using Microsoft ActiveSync and either a USB or serial cable and a cradle.

With Microsoft ActiveSync, you can:

- Synchronize information manually or automatically
- Synchronize information with your server while connected to your personal computer
- Move files to and from your personal computer
- Install applications on your iPAQ Pocket PC
- Back up and restore information on your personal computer

Sync with Personal Computer



CAUTION: For synchronization to work properly, install Microsoft ActiveSync before you connect your iPAQ Pocket PC to your computer.

During installation, you can:

- Create partnerships, which allow you to synchronize information with multiple computers
- Select the information to synchronize with your iPAQ Pocket PC (for example, Contacts, Calendar, Inbox, Tasks, Favorites, Files, Notes, and AvantGo)



If you have selected to synchronize files, you should drag and drop the selected files from your computer to the synchronized folder for your Compaq iPAQ Pocket PC on your desktop. If you named your Pocket PC, PC1, when you created your partnership, then the synchronized folder is named “PC1.” When you synchronize, the files are copied to your iPAQ Pocket PC.

To Sync with a Personal Computer:

1. Insert the HP iPAQ Pocket PC companion CD into your computer.
2. Follow the instructions in the installation wizard. For more help, click the ActiveSync **Help** button during installation.

The information you select will automatically synchronize when your installation is complete.

Use the Serial Infrared (IR) Connection

After setting up a connection with a USB or serial cable and a cradle, synchronize your iPAQ Pocket PC and your computer using an infrared connection if you have an infrared port or an infrared USB adapter installed on your computer. The infrared connection option works only on computers that have Windows 98, Me, XP, or 2000 operating system installed.

1. Follow the steps in “To Sync with a Personal Computer.”
2. Follow your computer manufacturer’s instructions to install and set up an infrared port.
3. From your computer, open **Microsoft ActiveSync**.
4. From the **File** menu, select **Connection Settings**.
5. Click “Allow serial cable or infrared connection to this COM port.”
6. Click the **OK** button.
7. Click the down arrow and choose **Infrared Port (IR)**.



Place your iPAQ Pocket PC and the infrared port so they are unobstructed and within 12 inches of each other.

8. From the **Start** menu on your iPAQ Pocket PC, tap **ActiveSync**.
9. Tap **Tools**.

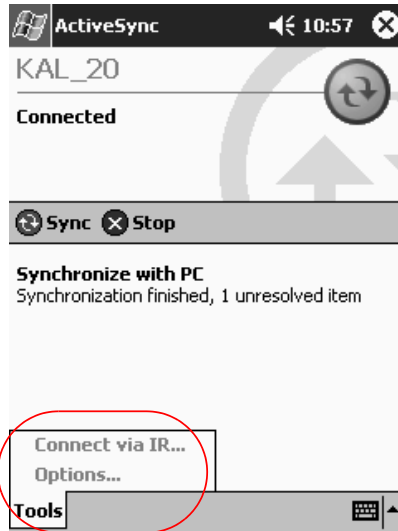

10. Tap **Connect via IR**.
11. Align the IR ports to establish a connection.
12. Move the devices away from each other to disconnect.

Change Synchronization Settings

You can modify your synchronization settings for Microsoft ActiveSync to:

- Change when your iPAQ Pocket PC synchronizes with your computer
- Change when your iPAQ Pocket PC synchronizes with your server
- Change the type of connection from your iPAQ Pocket PC to your computer (for example, serial, USB, infrared connections, Bluetooth, and wireless LAN)

- Select the files and information to synchronize with your computer
- Select the files and information you do not want to synchronize with your computer (for example, e-mail attachments)
- Determine how conflicts between information on your iPAQ Pocket PC and information on your computer are handled

To change synchronization settings:

1. From your computer, open **Microsoft ActiveSync**.
2. From the **Tools** menu, click **Options**.
 - a. On the **Sync Options** tab, select the files and information to synchronize with your computer.
 - b. On the **Sync Mode** tab, select when your iPAQ Pocket PC synchronizes with your computer.



To find out more information, collect information in list and make selections.

- c. On the **Rules** tab, determine how conflicts between information on your iPAQ Pocket PC and information on your computer are handled.

Move Files

You can move files to and from your computer using **Explore** in ActiveSync and Windows Explorer.



It is recommended that you store important information to the **iPAQ File Store** folder located in the **File Explorer** on your iPAQ Pocket PC.

To move files:

1. From your computer, open **Microsoft ActiveSync**.
2. Click **Explore**.
3. Double-click the **My Pocket PC** icon.

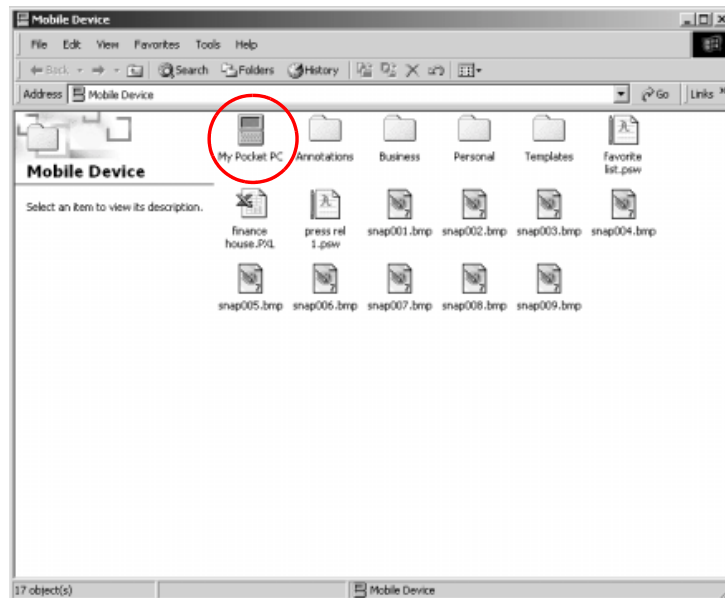

4. Right-click the **Start** menu on your personal computer, then select **Explore**.
5. Locate the file you want to move.

6. Drag and drop your files between your Pocket PC and Windows Explorer. ActiveSync converts the files, so that they can be used by the Pocket Office applications, if necessary.

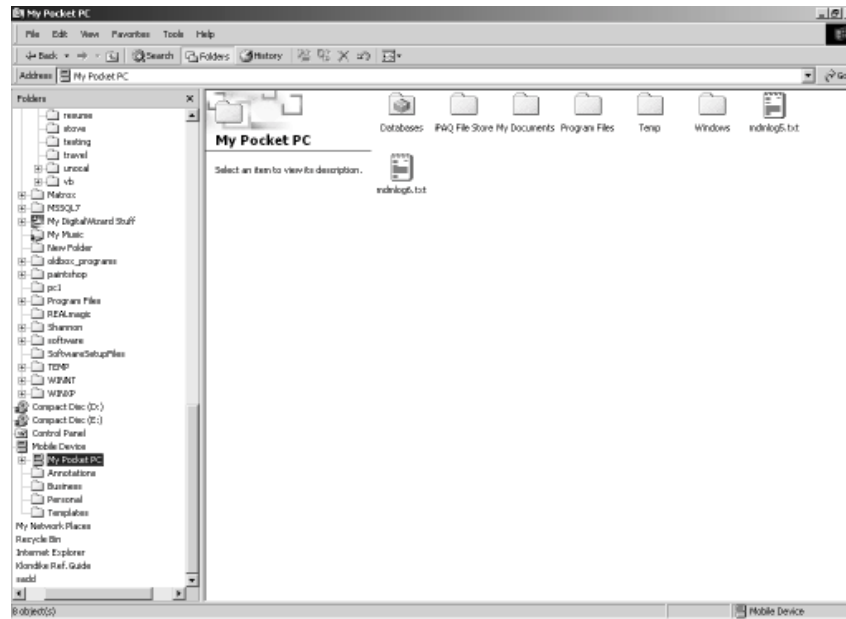

CAUTION: You should move your files directly into My Documents or into a folder inside your My Documents folder, so the applications on your iPAQ Pocket PC can find your files.

Connect to the Internet or Your Network

To send and receive e-mail with Inbox and view Web sites with Pocket Internet Explorer, you can set up a remote connection using:

- Wireless LAN (see Chapter 3)
- Bluetooth (see Chapter 4)
- Modem card

Use a Modem Card

To connect to the Internet with a modem card, you need a phone line, a dial-up Internet Service Provider, and an optional Single-Slot or Dual-Slot PC Card Expansion Pack, Expansion Pack Plus, or CompactFlash (CF) Card Expansion Pack.



Insert your modem card before trying to set up a modem connection.

To connect using a modem card:

1. Insert your modem card into an expansion pack.
-



If your modem card is not recognized, follow your modem manufacturer's instructions to install the modem card driver on your computer.

2. From the **Start** menu, tap **Settings**.
3. Tap the **Connections** tab, then tap the **Connections** icon.

4. Make sure **Internet Settings** is selected.

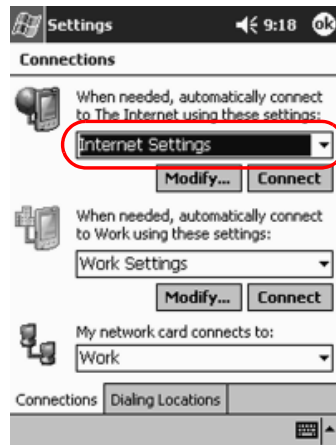

5. Tap **Modify**, then **New**.
6. Enter a name for the connection, select the modem type, then select the correct baud rate for that modem.
7. If you need to enter the TCP/IP settings, tap **Advanced**, then tap **TCP/IP**.
8. Select “Use specific IP address.”
9. Enter your IP address.
10. Tap **OK**, then **Next**.
11. Enter the phone number for your Internet Service Provider, then tap **Next**.

12. Tap **Finish** to set up the modem connection.

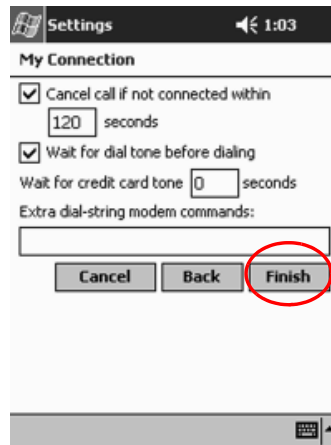

13. Tap **OK**.
14. Tap **OK** to return to **Settings**.

Synchronize Links

You can synchronize links to Web sites from your **Favorites** list on your personal computer to view them with Pocket Internet Explorer.

To synchronize links to Web sites:

1. From the **Start** menu on your personal computer, click **Programs**.
2. Open **Internet Explorer** on your personal computer.
3. Click **Favorites** to see the list of links to your favorite Web sites.
4. To save a Web site link to Mobile Favorites, open the Web site, then click **Create Mobile Favorite**.

If you selected “Favorites” as an information type to be synchronized, ActiveSync will copy your mobile favorite to your iPAQ Pocket PC the next time you synchronize.

Enter an Internet Address (URL)

With Pocket Internet Explorer and a connection to the Internet, you can view Web sites on your iPAQ Pocket PC by typing a URL in the **Address** bar.



Web sites that use HTML 4.0, DHTML, animated GIF images, and Java applets may not work correctly in Pocket Internet Explorer. For more information, see the Bonus software on the CD.

To enter an Internet address:

1. From the **Start** menu, tap **Internet Explorer**.
2. Tap **View**, then **Address Bar**.
3. Enter the address (URL) in the **Address** bar.
4. Tap the **Go** icon.

Select from a Favorites List

With Pocket Internet Explorer and a connection to the Internet, you can view Web sites on your iPAQ Pocket PC by selecting a Web site from your **Favorites** list.

To select from a **Favorites** list:

1. From the **Start** menu, tap **Internet Explorer**.
2. Tap the **Favorites** icon and the Web site you want to view.



Communicating

Your HP iPAQ Pocket PC h5400 Series lets you communicate in many ways:

- Create and organize contacts
- Use the e-mail Inbox
- Record messages with the microphone
- Take notes
- Use MSN messenger

Work with Contacts

You can enter and view information about friends, family members, or business associates in the Contacts application.

You can:

- Create a contact
- View and edit a contact
- Categorize your contacts
- Delete a contact



Press the **Contact** application button to navigate quickly to Contacts.

Create a Contact

You can create a contact from the **Start** menu or **Today** screen.

To create a contact:

1. From the **Start** menu, tap **Contacts**.
2. Tap **New** to create a new contact.
3. Tap any item and enter information. Scroll down to see more fields.
4. Tap the down arrow next to any item and enter additional details about the item.

For example, tap the **Name** down arrow to enter the contact's title, first, middle, and last name, and suffix.

5. Tap **OK** to save the contact information and return to the list of contacts.

View a List of Contacts

1. From the **Start** menu, tap **Contacts** to display a list of your contacts from the last category selected.
2. Tap the down arrow next to the category name to see the list of categories.



3. Tap a category name to see a list of contacts placed in that category.
4. Tap a contact's name.

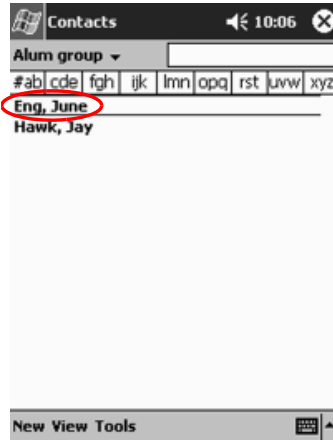

Edit Contact Information

1. Tap a contact's name.
2. Tap **Edit** to see the contact information.
3. Edit the contact information.
4. Tap **OK** to save the contact information and return to the list of contacts.

Categorize Contacts

You can use categories to filter your list of contacts. This helps you view and edit your contact information.



A category will not display unless a contact has been assigned to it.

To categorize contacts:

1. From the **Start** menu, tap **Contacts**.

2. Tap a contact's name.
3. Tap **Edit** to see the contact information.



4. Tap the **Categories** field to see a list of available categories.
You may have to scroll down to see the **Categories** field.

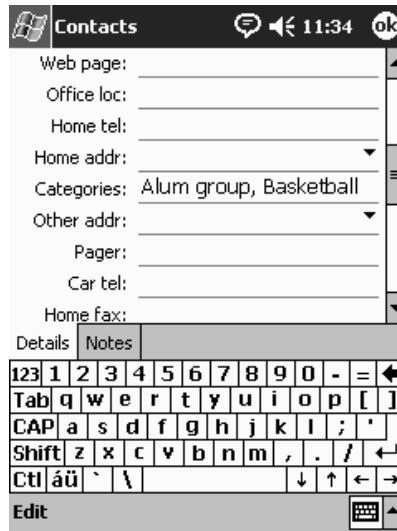

5. Tap the **Add/Delete** tab to create a category.

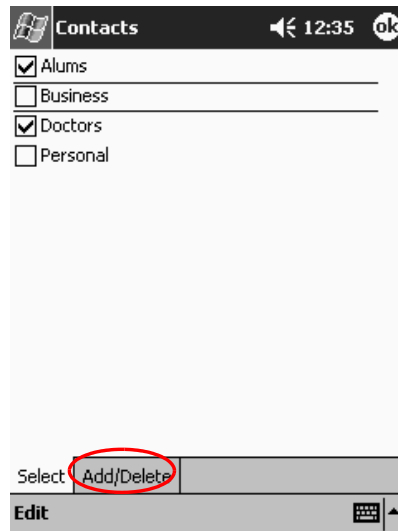

6. Enter the name of the new category, then tap **Add**.

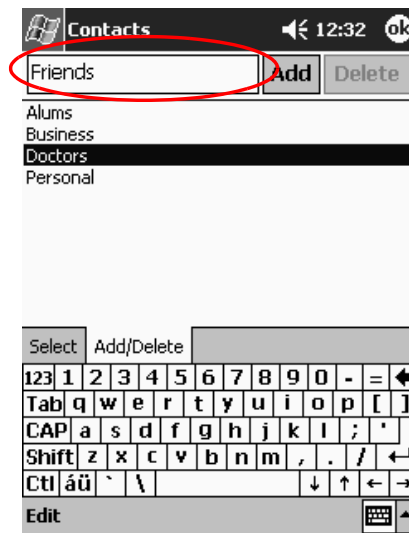

7. Tap **OK** to place your contact in the category.

8. Tap the **Categories** field again to place your contact in additional categories.
9. Tap additional category names to select them, then tap **OK** to list the categories you selected in the **Categories** field.
10. Tap **OK** to save the category information and return to the list of contacts.

Delete Contacts



CAUTION: If you delete a contact on your iPAQ Pocket PC and synchronize Contacts with your computer, you may delete the contact in Outlook on your computer.

To delete contacts:

1. From the **Start** menu, tap **Contacts** to see a list of your contacts from the last category selected.
2. Tap the down arrow next to the category name to see a list of categories.

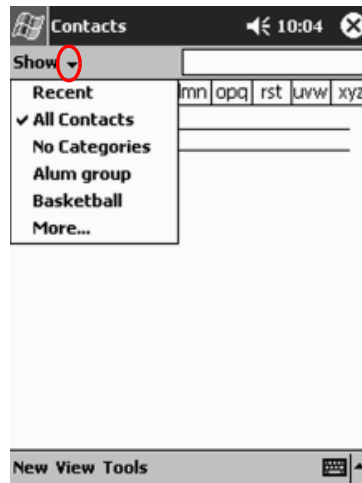

3. Tap a category name to see a list of contacts placed in that category.

4. Tap and hold a contact's name to see a pop-up menu.

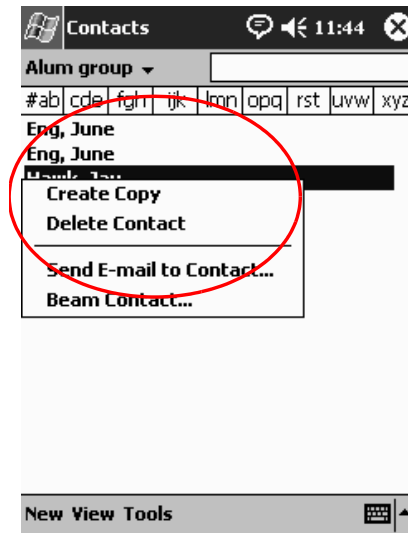

5. Tap **Delete Contact** to remove the contact from the list.
6. Tap **Yes** to delete the contact permanently.

Use the Inbox

Send and receive e-mail by synchronizing your iPAQ Pocket PC with your computer using Microsoft ActiveSync or connecting to the Internet or network through an e-mail service.

Use ActiveSync to send and receive e-mail. You can read and compose e-mail offline using your iPAQ Pocket PC. The e-mail remains in the Outbox until you synchronize with your personal computer.

You see the name of the folder you are using at the bottom of the screen. If you are using an e-mail service, use that folder to send and receive e-mail.

The Inbox on your iPAQ Pocket PC is similar to the Inbox on your computer. E-mail is saved in 5 default folders:

- Inbox
- Outbox
- Deleted Items
- Drafts
- Sent Items

Set Up E-mail

If you are using a wireless Internet or network connection, you must set up an e-mail service.

To set up e-mail service:

1. From the **Start** menu, tap **Inbox**.
2. Tap **Services**.
3. Tap **New Service**.

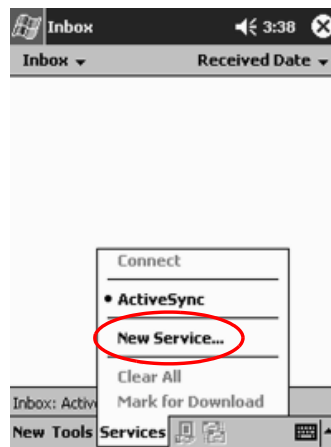

4. Enter configuration information for your wireless e-mail service in the next 5 screens. Tap **Next** when finished with each one.



Tap the **Question Mark** icon for help on any screen.

Compose/Send E-mail

You can compose e-mail from the **Inbox** or **Today** screen.

If you want to compose and send e-mail, tap **Services** in the **Inbox**, then select the e-mail service you want to use (see “Set Up E-mail”).

To compose and send e-mail:

1. From the **Start** menu, tap **Inbox**.
2. Tap **New** to compose a new e-mail.

3. Tap **Send** to place the e-mail in the **Outbox**.

The e-mail is sent when you synchronize or automatically if you are connected to the Internet or your network through a wireless e-mail service.



4. If you do not want to send your e-mail yet, tap **OK** to leave your e-mail in the **Drafts** folder.



When you are ready to send your e-mail, reestablish your wireless connection, tap **Open**, then **Send**.

Add an Attachment

1. From the **Start** menu, tap **Inbox**.
2. Tap **New** to write a new e-mail.
3. Tap **Edit**.
4. Tap **Add Attachment** to see all folders in My Documents.

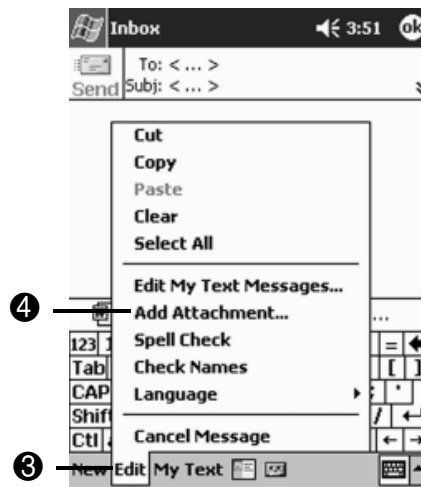

5. Tap the file you want to attach. You may have to scroll to view your document name.

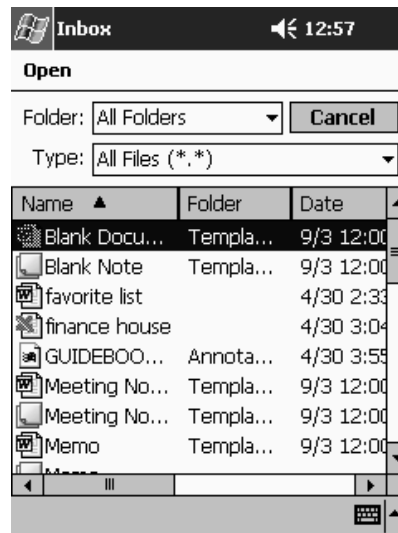

6. See the file name you selected below the body of the e-mail.

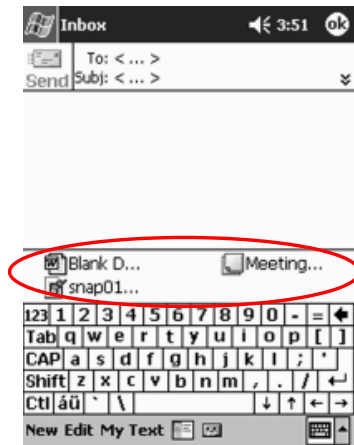

You can record a message and attach it to an e-mail.

Receive E-mail

Receive e-mail by synchronizing your iPAQ Pocket PC Inbox with your computer using ActiveSync or connecting to the Internet or your network through an e-mail service.

If you are using ActiveSync, you can synchronize your personal folders from Outlook on your computer with **Inbox** on your iPAQ Pocket PC.



You do not receive e-mail attachments by default. You can select this option in ActiveSync.

To receive e-mail:

1. From the **Start** menu, tap **Inbox**.
2. Tap **Services**.



3. Tap the e-mail service you want to use.
4. If you have not set up an e-mail service, synchronize your iPAQ Pocket PC with your computer.

Open E-mail

1. From the **Start** menu, tap **Inbox**.
2. Tap the down arrow next to **Inbox** to see a list of your folders.

3. Tap the folder where you have saved the e-mail.

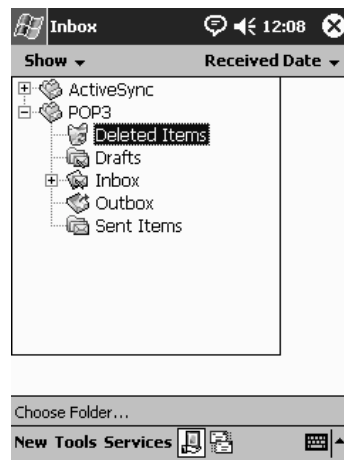

4. Tap the e-mail to open it.

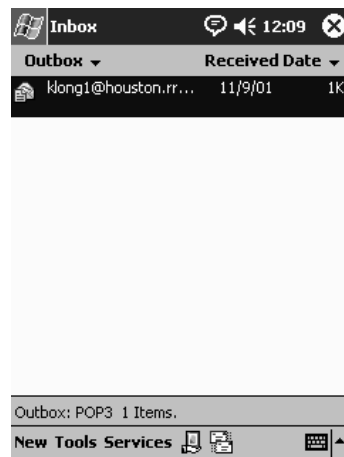

Delete E-mail

When you delete e-mail, it is placed in the **Deleted Items** folder, but the e-mail is not permanently deleted until you tap **Empty Deleted Items** from the **Tools** menu.

To delete e-mail:

1. From the **Start** menu, tap **Inbox**.
2. Tap the folder where you have saved the e-mail.

3. Tap and hold the e-mail you want to delete.
4. Tap **Delete** to move the e-mail to the **Deleted Items** folder.

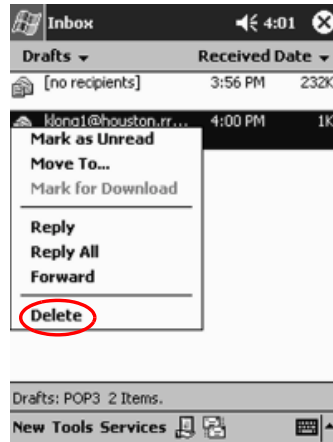

5. Tap **Tools**, then **Empty Deleted Items** to permanently delete the e-mail.

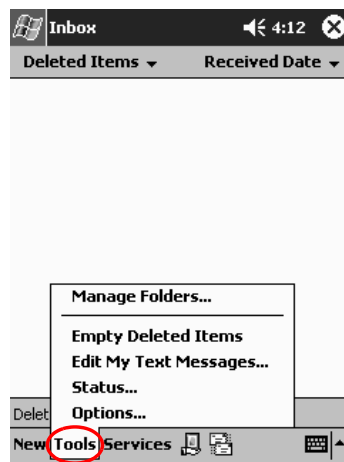

CAUTION: When you delete e-mail from your iPAQ Pocket PC, you also delete it from your personal computer.

Manage Folders

You can use folders to organize your e-mail if you are using an e-mail service. You can create additional folders that you can rename or delete.

If you are using ActiveSync, you **cannot** create additional folders in the Inbox. However, you can synchronize your personal folders from Outlook on your computer with Inbox on your iPAQ Pocket PC. You **cannot** rename or delete these folders in Inbox.

1. From the **Start** menu, tap **Inbox**.
2. Tap **Services**.
3. Tap the wireless e-mail service you want to use.
4. Tap **Tools**, then **Manage Folders**.

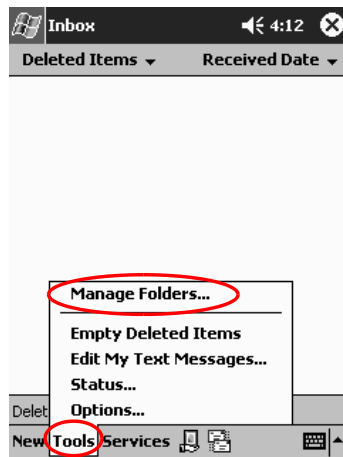

5. Tap **New** to create a new folder.

6. Tap **Rename** to rename a folder.



7. Tap **Remove Folder** to delete a folder you created.

8. Tap **Yes** to permanently delete the folder.

Record Voice

You can record your voice or any other sound as a note within the Calendar, Contacts, Notes, and Tasks applications. In the Notes application, you can create stand-alone recordings, which are stored as separate .wav files in File Explorer.



To quickly make a recording, press the **Record** button. If you have re-programmed the Record button, follow the steps in “Make a Recording” section.

Make a Recording

1. From the **Start** menu, tap **Notes**.
2. Tap the **Cassette Tape** icon located at the bottom of the screen to see the recording controls.



3. Tap the **Record** icon to start recording.
4. Position the microphone to record your voice or other sounds.
5. Tap the **Stop** icon to finish recording.



To improve the quality of your recording, tap **Settings, System, iPAQ Audio**, then **Microphone AGC**.

Listen to a Recording

1. From the **Start** menu, tap **Notes**.
2. Tap a recording.
3. Tap the **Speaker** icon to listen to a recording.

Take Notes

You can take notes in the Calendar, Contacts, Notes, and Tasks applications. You can type, write, draw, or record in your note. In the Notes application, you can compose an original note or a note based on a template.

You can create a note from the **Start** menu or **Today** screen.

Create a Note

1. From the **Start** menu, tap **Notes**.
2. Tap **New**.
3. Tap anywhere and enter your note.



4. Tap **OK** to save your note and place it in the list of notes.

Scheduling

Your iPAQ Pocket PC h5400 Series helps you keep track of your schedule in many ways. You can:

- See information at a glance on the **Today** screen
- Set appointments and create reminders with the Calendar
- Create a task list

Use the Today Screen

Use the **Today** screen to view your:

- Owner information
- Upcoming appointments
- Unsent messages
- Tasks that need to be completed

When you set up your device, you'll first see the **Today** screen.



You will also see the **Today** screen when you turn on your device for the first time each day or after 4 hours of inactivity.

You can also display it by tapping  then **Today**. On the **Today** screen, you can see at a glance the information you need for the day.

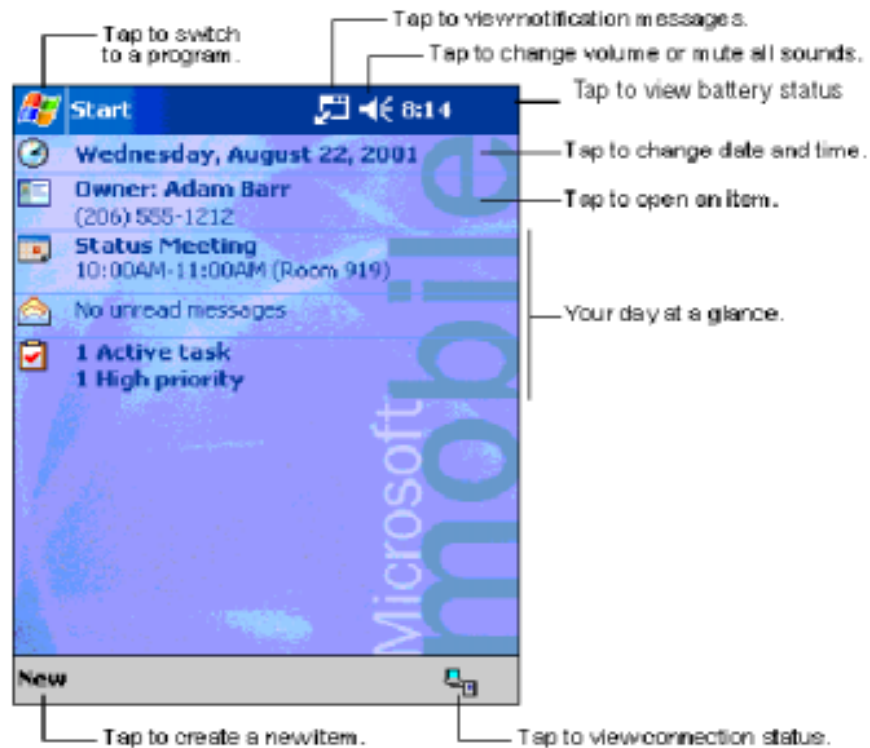

Create Information

From the **Today** screen, create new information, including:

- Appointments
- Contacts
- E-mail
- Excel Workbook Information
- Notes
- Tasks
- Word documents

To create information:

1. From the **Start** menu, tap **Today**.
2. Tap **New**.
3. Tap an option to create a new item.
4. Tap **OK** when finished creating the new item.

Change Information

From the **Today** screen, you can change:

- Owner information
- Upcoming appointments
- Unsent messages
- Tasks that need to be completed

For more information on changing these items, see the appropriate instructions for each task in this guide. For example, to create a new appointment, see “Schedule Appointments” later in this guide.

1. From the **Start** menu, tap **Today**.
2. Tap the information you want to change.
3. Enter or change the information.
4. Tap **OK** to save changes and return to the **Today** screen.

Change Settings

From the **Today Settings** screen, you can:

- Add a picture as the background
- Select the information you see
- Set the order of the information
- Decide when to see the **Today** screen

To change the background:

1. From the **Start** menu, tap **Settings**.
2. Tap **Today**.
3. Select “Use this picture as the background” check box.



4. Tap **Browse** to select a picture from File Explorer.

To change the order of information:

1. From the **Start** menu, tap **Settings**.
2. Tap **Today**.
3. Tap the **Items** tab to select or reorder the information on the **Today** screen.

4. Tap an item to highlight it.

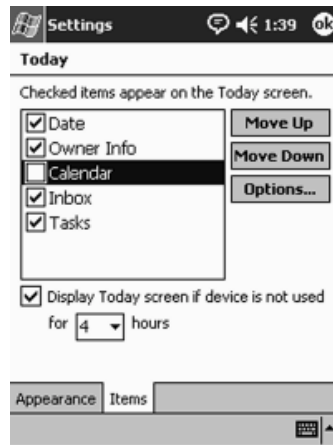

5. Tap **Move Up** or **Move Down** to change the order of items on the **Today** screen.



You cannot change the placement of the **Date** on the **Today** screen.

6. Tap the down arrow associated with “Display Today screen if device is not used for...hours” check box to determine how many hours must pass before the **Today** screen displays.

7. Tap **OK**.

Use the Calendar

You can use the Calendar to schedule appointments and set reminders. You can view your calendar by:

- Agenda
- Day
- Week
- Month
- Year



Tap the **Calendar** icon on the **Today** screen to navigate quickly to Calendar.

Look at the Calendar

By default, the Calendar first appears in the **Agenda** view. The **Agenda** view provides the most detail about your appointments.

From the **Start** menu, tap **Calendar** to view your appointments.

Change the Calendar View

By default, the Calendar first appears in the **Agenda** view, which provides the most detail about your appointment. You can also view your calendar by:

- Day
- Week
- Month
- Year

1. From the **Start** menu, tap **Calendar**.
2. Tap the **Agenda, Day, Week, Month,** or **Year** icon to see your calendar in that view.

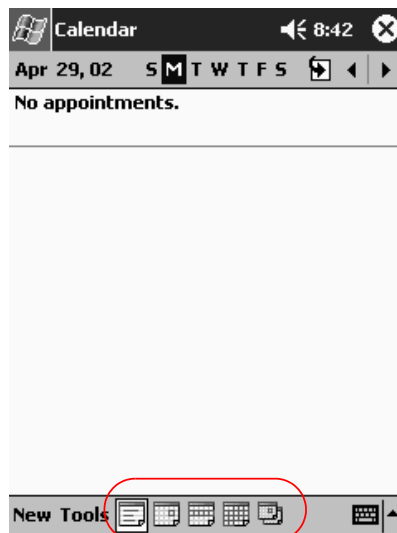

Customize the Calendar Appearance

You can change the appearance of your calendar by setting the 1st day of the week, deciding how many days in a week you want to view, showing the number of weeks and the half-hour time slots, deciding to use a large font, and deciding to set reminders for new items. You can also display several icons that give visual information about your appointments, including:

- Reminder
- Recurrence
- Note
- Location
- Attendees
- Private

You can determine whether to send meeting requests through ActiveSync or an e-mail service.

To customize the calendar appearance:

1. From the **Start** menu, tap **Calendar**.
2. Tap **Tools**.
3. Tap **Options**.
4. Select the calendar options.
5. Tap **OK**.

Schedule Appointments

1. From the **Start** menu, tap **Calendar**.
2. Tap **New** to schedule an appointment.
3. Enter a subject or select from the **Subject** drop-down list.

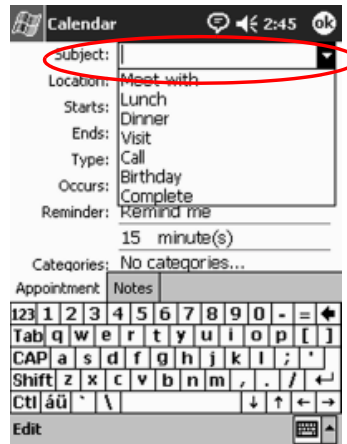

4. Tap any item to enter additional information.
5. Tap **OK** to schedule the appointment.



You can schedule an appointment and set a reminder from the **Today** screen.

Create Reminders

You can create a reminder when you are scheduling an appointment or you can do it at a later date.

To create reminders:

1. From the **Start** menu, tap **Calendar**.
2. Tap an appointment.

3. Tap **Edit**.
4. Tap the second **Reminder** field to select the time interval between reminders. The default is 15 minutes.

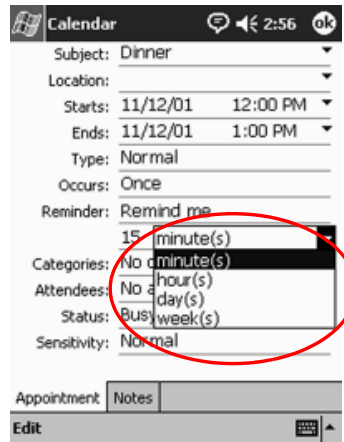

Delete Appointments

1. From the **Start** menu, tap **Calendar**.
2. Tap an appointment.
3. Tap **Tools**.
4. Tap **Delete Appointment**.

Categorize Appointments

You can use categories to filter the appointments in your calendar.

To categorize appointments:

1. From the **Start** menu, tap **Calendar**.
2. Tap an appointment.
3. Tap **Edit**.
4. Tap the **Categories** field to see a list of available categories.
5. Tap **Add/Delete** to create a category.

6. Enter the name of the new category.

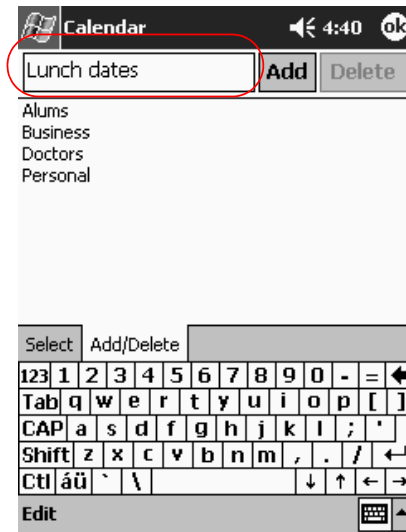

7. Tap **Add**.
8. Tap **OK** to place your appointment in the category.
9. Tap the **Categories** field to place your appointment in more categories.
10. Tap additional category names to select them.
11. Tap **OK** to list the categories you selected in the **Categories** field.
12. Tap **OK** to save the category information and return to the **Calendar** screen.

Request Meetings

You can schedule a meeting and send a meeting request through ActiveSync or an e-mail service.



You must enter contacts with e-mail addresses in the Contacts application and set up the Inbox application to send and receive e-mail before you can send a meeting request.

To request a meeting:

1. From the **Start** menu, tap **Calendar**.
2. Tap **Tools**.
3. Tap **Options**.
4. Tap the “Send meeting requests via” down arrow.
5. Tap the e-mail service you want to use to send a meeting request, then tap **OK**.
6. Tap **New** to create a new appointment.
7. Enter the information.
8. Tap the **Attendees** field.
9. Tap the contacts you want to invite to the meeting.
10. Tap **OK** to add the attendees.
11. Tap **OK** to schedule the meeting.
12. Tap **Yes** to inform attendees about the meeting.

Use Tasks

You use Tasks to:

- Create new tasks
- Set a reminder for a task
- Delete a task
- Sort your task list by category, status, priority, subject, start date, and due date

Create a Task

You can create a task from the **Today** screen.

To create a task:

1. From the **Start** menu, tap **Tasks**.
2. Tap **New** to create a new task.
3. Enter a subject or select from the **Subject** drop-down list.

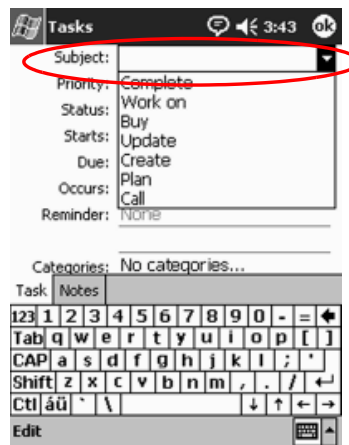

4. Tap any item to enter additional information.
5. Tap **Due** to add a due date for the task.

6. Tap **Reminder**, then select “Remind me.”
7. Tap the date to select when you want to be reminded.
8. Tap **OK** to set the reminder and create the task.

Create a Task Quickly

You can create a task quickly by customizing Tasks, so you see an **Entry Bar** at the top of the **Tasks** screen.



To quickly create a task:

1. From the **Start** menu, tap **Tasks**.
2. Tap **Tools**.
3. Tap **Entry Bar**.
4. Enter the subject.
5. Set a priority:
 - a. For high priority, tap the **exclamation point**.
 - b. For low priority, tap the **down arrow** icon.
 - c. For normal priority, do not tap an icon.
6. Tap outside the **Entry Bar** to add the task to your task list.

Delete a Task

1. From the **Start** menu, tap **Tasks**.
2. Tap the task you want to delete.
3. Tap **Tools**.
4. Tap **Delete Task**.
5. Tap **Yes** to permanently delete the task.

Sort Tasks

1. From the **Start** menu, tap **Tasks**.
2. Tap the down arrow at the top left of the screen to sort the task list by category.
3. Select a category.

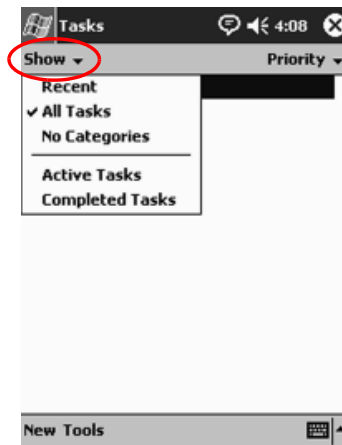

4. Tap the down arrow at the top right of the screen to sort the task list by status, priority, subject, start date, or due date.
5. Select a sort option.

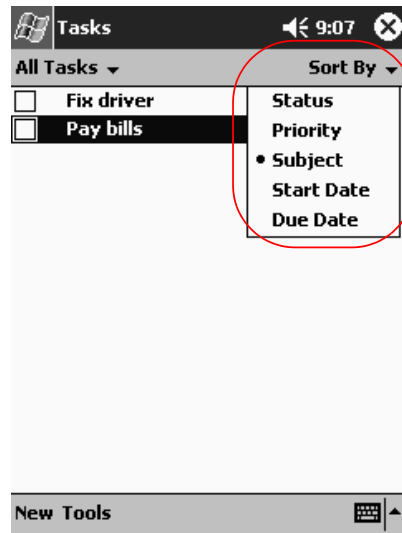

Change Appearance of Tasks

You can change the appearance of Tasks to use a large font, show the start and end dates, and set reminders for new items.

1. From the **Start** menu, tap **Tasks**.
2. Tap **Tools**.
3. Tap **Options**.
4. Select the **Tasks** options.
5. Tap **OK**.

Using Software

You can use the applications on your iPAQ Pocket PC h5400 Series to:

- Open or create Word documents
- Open or create Excel workbooks
- Read eBooks with Microsoft Reader*
- Use the Media Player
- Use Pocket Internet Explorer

*The Microsoft Reader may not be available in your country.

Use Pocket Word

You can create new Word documents from your iPAQ Pocket PC or synchronize existing Word documents from your computer to your iPAQ Pocket PC.

Microsoft ActiveSync converts Word documents into the Pocket Word format and changes the .doc extension to a .psw extension.



CAUTION: Because ActiveSync converts Word documents into the Pocket Word format, you may lose some formatting from the original Word document.

Pocket Word does not support items like:

- Columns
- Numbered lists
- Headers and footers
- Footnotes
- Style sheets



For more help with Pocket Word, tap **Help** from the **Start** menu, tap **Pocket Word**.

Create a New Document



Create a new document from the **Today** screen by tapping **New**.

To create a new document:

1. From the **Start** menu, tap **Programs**.
2. Tap **Pocket Word**.
3. Tap **New** to create a new document.

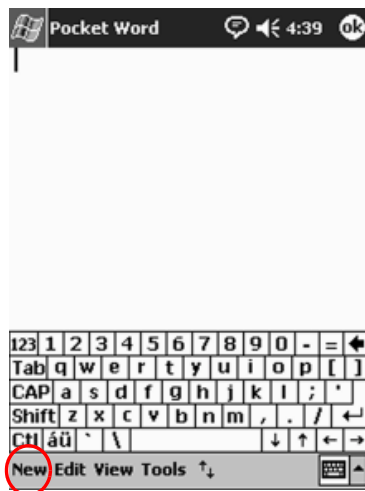

4. Tap **View**, then tap **Toolbar** to format text.

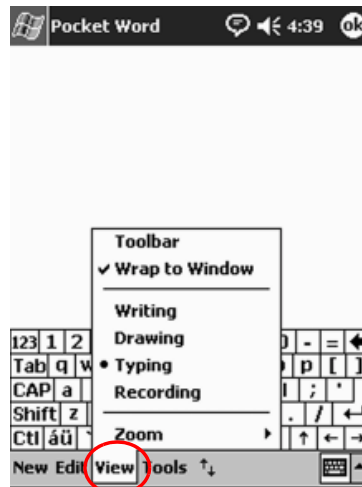

5. Tap **OK** to close and save the document.

The document is automatically saved as a Pocket Word Document with the first few words of your text as its name. You may want to rename it.



You can install applications and save files to the iPAQ File Store folder. The iPAQ File Store is accessed from the File Explorer on your iPAQ Pocket PC. You can store up to 20 MB of information (see section “Save to File Store.”).

Applications and files stored in the iPAQ File Store are held in ROM and are saved if you perform a full reset of your iPAQ Pocket PC or if the battery discharges completely.

Open a Word Document

 **CAUTION:** Pocket Word only recognizes and displays documents saved in the My Documents folder or 1 folder below it. Files saved elsewhere cannot be displayed.

To open a Word document:

1. From the **Start** menu, tap **Programs**.
2. Tap **Pocket Word**.
3. Tap a document to open it.

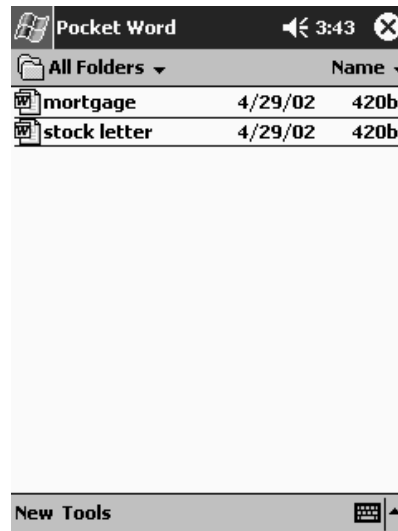

Change the Pocket Word Options

You can select:

- A default template
- Whether documents are stored in main memory or on a storage card
- Which types of documents are displayed in the list view

To change Pocket Word options:

1. From the **Start** menu, tap **Programs**.
2. Tap **Pocket Word**.
3. Tap **Tools**, then **Options**.

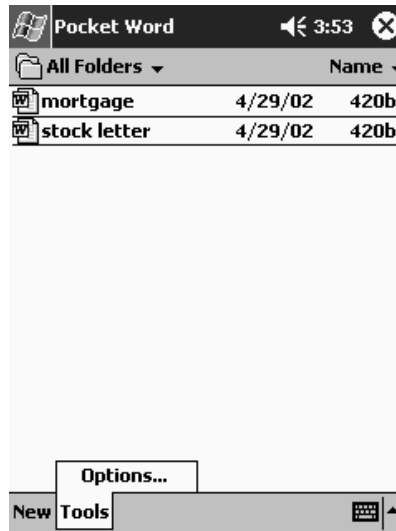

4. Tap the **Default template** down arrow to select a default template.

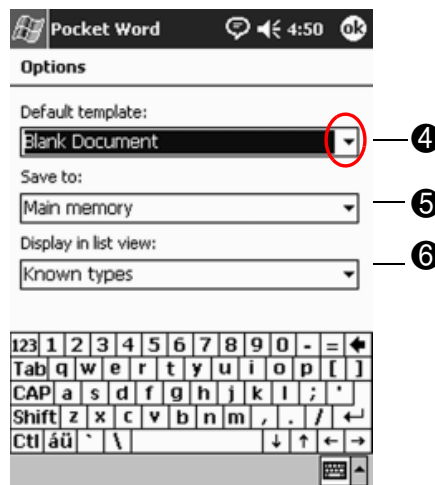

5. Tap the **Save to** down arrow to store documents in main memory or on a storage card.

6. Tap the **Display in list view** down arrow to select which types of documents to display in the list view.

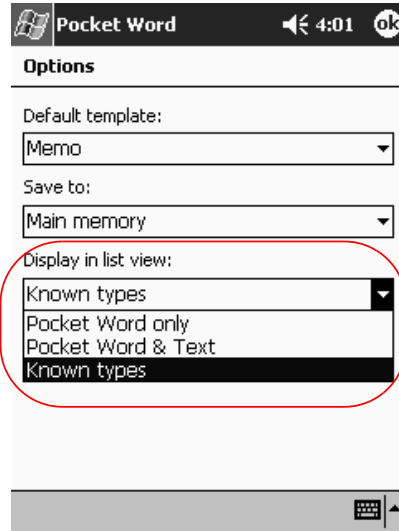

7. Tap **OK** to save the options.

Use Pocket Excel

You can create Excel workbooks from your iPAQ Pocket PC or synchronize existing Excel workbooks from your computer to your iPAQ Pocket PC. ActiveSync converts Excel workbooks into the Pocket Excel format and changes the .xls extension to a .pxl extension.



CAUTION: Because ActiveSync converts Excel workbooks into the Pocket Excel format, you may lose some formatting from the original Excel workbook.

Pocket Excel does not support items like:

- Data validation
- Cell notes
- Add-ins
- Protection
- Scenarios
- Object charts
- Vertical alignment
- Text boxes
- Embedded OLE objects
- Hyperlinks



For more help with Pocket Excel, tap **Help** from the **Start** menu, tap **Pocket Excel**.

Create a Workbook



You can create a new workbook from the **Today** screen by tapping **New**.

To create a workbook:

1. From the **Start** menu, tap **Programs**.
2. Tap **Pocket Excel**.

3. Tap **New** to create a new workbook.
4. Tap **OK** to close and save the workbook.

The workbook is automatically saved as a Pocket Excel workbook named Book1. Depending on how many workbooks you have created since opening Pocket Excel, you may want to rename it.



You can install applications and save files to the iPAQ File Store folder. The iPAQ File Store is accessed from the File Explorer on your iPAQ Pocket PC. You can store up to 20 MB of information (see section “Save to File Store.”)

Applications and files stored in the iPAQ File Store are held in ROM and are saved if you perform a full reset of your iPAQ Pocket PC or if the battery discharges completely.

Open an Excel File



CAUTION: Pocket Excel only recognizes and displays documents saved in the My Documents folder or 1 folder below it. Files saved elsewhere cannot be displayed.

To open an Excel file:

1. From the **Start** menu, tap **Programs**.
2. Tap **Pocket Excel**.
3. Tap a workbook to open.

Change Excel Options

You can change options to select:

- A template for new workbooks
- Whether workbooks are stored in main memory or on a storage card
- Which types of workbooks are displayed in the list view

To change Excel options:

1. From the **Start** menu, tap **Programs**.
2. Tap **Pocket Excel**.
3. Tap **Tools**, then **Options**.
4. Tap the **Template for new workbook** down arrow to select a template.

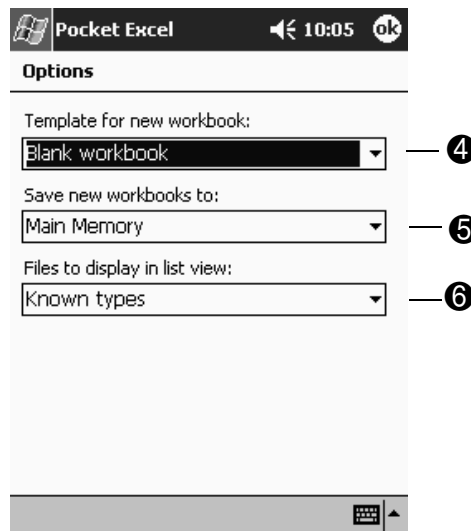

5. Tap the **Save new workbooks to** down arrow to store workbooks in main memory, iPAQ file store, or on a storage card.

6. Tap the **Files to display in list view** down arrow to select which workbooks are displayed in the list view.

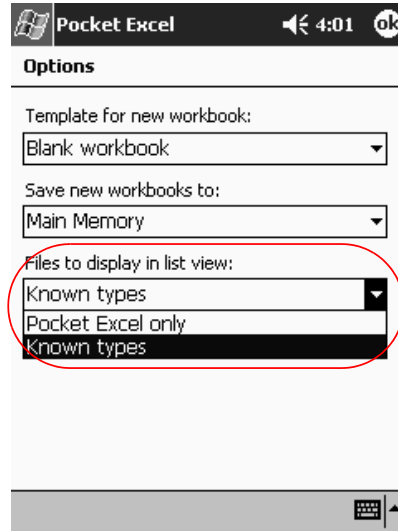

7. Tap **OK** to save the options.

Use Microsoft Reader

Use Microsoft Reader to read and listen to eBooks. You must activate the Microsoft Reader the first time you use it. Before you can copy protected eBooks from the Internet, the reader must be activated. To activate your reader, you must have a Hotmail, MSN, or Passport account.

The Microsoft Reader is available in select countries.



The iPAQ Pocket PC Reference Guide is available as an eBook in some countries. You can copy it to your iPAQ Pocket PC from the Companion CD.

Activate the Reader

You must activate the Microsoft Reader to copy protected eBooks.

To activate the reader:

1. Connect your iPAQ Pocket PC to your computer.
2. Open **Internet Explorer** on your computer.
3. Go to <http://das.microsoft.com/activate>.

Read an eBook

Read your eBook from start to finish or select specific topics. If you close your eBook and later want to open it, your eBook will open on the last page you read.

To read an eBook:

1. From the **Start** menu, tap **Programs**.
2. Tap **Microsoft Reader**.
3. Tap the title of your eBook.



4. Tap the page number or left and right arrows to move backward and forward in the book.

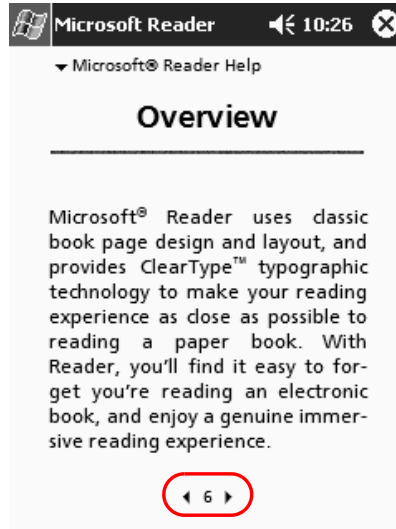

To jump to a topic, tap a link. Links can occur throughout the text or table of contents. To return from a link, tap the title of the eBook, then tap **Return**.

Copy eBooks

You can copy eBooks from any eBook retailer to your iPAQ Pocket PC.

To copy an eBook:

1. Connect your iPAQ Pocket PC to your computer.
2. Go to any eBook retailer's Web site and follow the directions for downloading or installing files to your iPAQ Pocket PC.



It is recommended that you store important information on a storage card such as a CompactFlash or SD card.

Delete eBooks

You can delete an eBook from your iPAQ Pocket PC library. If your eBook is stored on your computer, you can copy it again to your iPAQ Pocket PC.

To delete an eBook:

1. From the **Start** menu, tap **Programs**.
2. Tap **Microsoft Reader**.
3. Tap and hold the title of your eBook.



4. Tap **Delete**.
5. Tap **Yes**.

Listen to an eBook

You can listen to an Audible eBook on your iPAQ Pocket PC. For more information on buying and listening to Audible eBooks, go to <http://www.audible.com>.

To listen to an eBook:

1. From the **Start** menu, tap **Programs**.
2. Tap **Microsoft Reader**.
3. Tap the title.
4. Tap **Play** to listen to the book.
5. Tap **Stop** to quit listening to the book.

Annotate your eBook

You can annotate your eBook using items like:

- Creating Bookmarks
- Highlighting Words Or Phrases
- Attaching Notes
- Creating drawings

To annotate your eBook:

1. From the **Start** menu, tap **Programs**.
2. Tap **Microsoft Reader**.

3. Tap the title.
4. Highlight and hold the text where you want to create an annotation, then tap **Add Bookmark**, **Add Highlight**, **Add Text Note**, or **Add Drawing** from the pop-up menu.

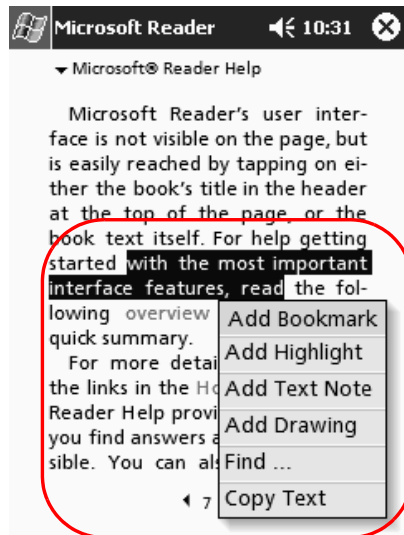

Change the Microsoft Reader Options

You can customize the Microsoft Reader to meet your individual needs. Choose to see visual guides, allow annotations (bookmarks, text notes, drawings, or highlights), or adjust the size of the font.

To change the reader options:

1. From the **Start** menu, tap **Programs**.
2. Tap **Microsoft Reader**.
3. Tap **Settings**.

4. Tap the **Visual Guides** option.

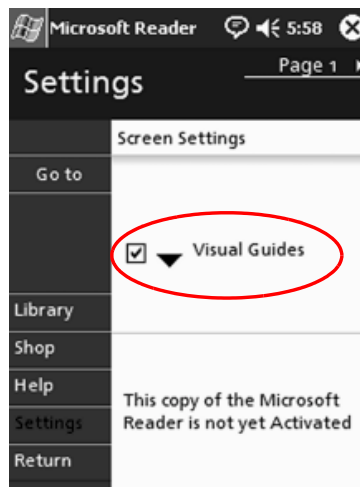

5. Tap **Page 1**.

6. Select the **Annotations** options.

7. Tap **Page 2**.

8. Tap and drag the cursor along the ruler to adjust the font size.



9. Tap **Library** to return to the list of eBooks.

Use the Windows Media Player

You can use the Windows Media Player to listen to music or play video from your iPAQ Pocket PC by downloading files:

- Onto your personal computer and transferring them to your iPAQ Pocket PC
- Directly onto your iPAQ Pocket PC using your wireless LAN



For more information about using Windows Media Player, tap the **Windows** icon, then **Help** from within the Media Player.

Media Player supports the organization and playback of:

- Windows Media content
- MP3 audio files
- Windows Media audio and video

- FhG MP3
- Streamed content in Windows Media format using WM protocols (HTTP and MMS)



Some Internet music files are protected by licensing technology. Windows Media Player uses Digital Rights Management (DRM) for the electronic licensing procedure. Windows Media Player and Windows Media Rights Manager must be installed on the personal computer and are available on Microsoft's Web site.

Copy Music to Your iPAQ Pocket PC

You can copy music that is in 1 of the accepted formats from your personal computer to the iPAQ Pocket PC. You drag and drop the music file into the My Documents folder located in RAM or on a storage card.

You must have the Windows Media Player installed on your personal computer to copy music from an audio CD to your iPAQ Pocket PC.

To copy music to your iPAQ Pocket PC:



The actual steps for copying music using the Windows Media Player may vary depending on the version of the Media Player on the personal computer.

1. Connect your iPAQ Pocket PC to your personal computer.
 2. Open Windows Media Player on your personal computer.
 3. Insert the audio CD into your CD drive.
 4. From Media Player on your personal computer, select **CD Audio** to display the tracks on the audio CD.
 5. Select the tracks to copy and select **Copy Music** to transfer the tracks to the hard drive.
 6. From Media Player on your personal computer, select **Portable Device** to display the tracks on the hard drive and the files on the iPAQ Pocket PC.
 7. Select the tracks to copy and the storage location on the iPAQ Pocket PC and select **Copy Music** to transfer the tracks.
-



Music files can be relatively large. It is recommended that you store your music files on a storage card.

Play Music on Your iPAQ Pocket PC

1. Tap **Start**, then **Windows Media**.
2. Tap **Select**.
3. Tap the down arrow and **Local Content** to display media files stored on the iPAQ Pocket PC.



4. Tap and highlight the desired file.

5. Tap the **Play** icon.



By default Media Player will play all files stored as local content on the iPAQ Pocket PC. You can repeat a file and shuffle the contents by selecting **Tools**, then **Repeat** or **Shuffle**.

Create Playlists

You can organize music and video files into playlists.

To create a playlist:

1. Tap **Start**, then **Windows Media**.
2. Tap **Select**.

3. Tap the down arrow, then **Organize Playlists**.



4. Tap **New** to name your playlist, then tap **OK**.

5. Select the files to include in this playlist.

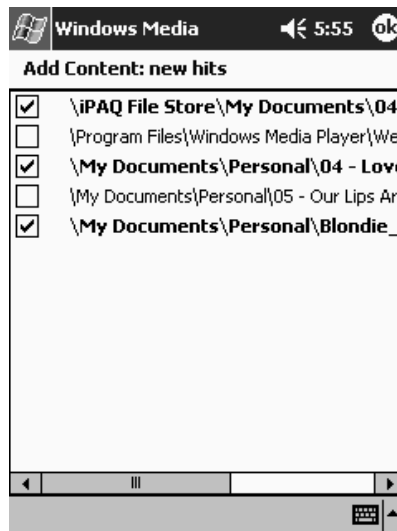

6. Tap **OK** to display your new playlist.

7. Tap **OK**.

Play a Playlist

1. Tap **Start**, then **Windows Media**.
2. Tap **Select**.
3. Tap the down arrow and tap the playlist name to display its contents.
4. Tap **OK**, then the **Play** icon to start the playlist.



You can delete and rename playlists by using the **Organize Playlists** menu option. You can also edit playlists by using the **Edit** icon while viewing a playlist.

Play Video

You can play and manage video files just like music. You must have an internet connection to play streaming video.

Use Pocket Internet Explorer

You can use Pocket Internet Explorer (Pocket IE) to view web or WAP pages on your iPAQ Pocket PC by downloading pages while connected to the Internet or through synchronization. While browsing, you can download files and programs to your iPAQ Pocket PC.



For more information, tap **Start**, **Help**, then **Pocket Internet Explorer**.

Use Pocket IE When Connected

With Pocket IE, you can use mobile browsing when connected to the Internet.

1. Tap **Start**.
2. Tap **Internet Explorer**.



You can use the pre-installed links that HP has provided to access content and services that are optimized for the iPAQ Pocket PC.

3. Enter the URL address in the address bar at the top of the screen. If you do not see the address bar, tap **View**, then tap **Address Bar**.
4. Tap **Go**.

Use Pocket IE When Disconnected

With Pocket IE, you can browse previously viewed and stored information when disconnected from the Internet. This information can be viewed using the cached content or through synchronization.

To view the cached content:

1. Tap **Start**.
2. Tap **Internet Explorer**.
3. Tap **Tools**, then **Options**.
4. In the **General** tab, select the number of days to save the history of pages visited.
5. Tap **OK**.

Synchronize Favorites

You can have the URLs of your favorite Web sites at your fingertips. Synchronizing a mobile favorite allows you to view Internet content on your iPAQ Pocket PC while you are disconnected.

To synchronize favorites:

1. In ActiveSync on your personal computer, click **Tools**, then **Options**.
2. Select the check box next to **Favorites**.
3. In Internet Explorer on your personal computer, save or move favorite links to the **Mobile Favorites** subfolder in the **Favorites** list.

The Favorites will be synchronized to your iPAQ Pocket PC at your next Sync connection.



If you add or delete a favorite link in the **Mobile Favorites** folder on your iPAQ Pocket PC, the next time you synchronize the same change is made on your personal computer.

Using the Universal Remote

You can use Nevo software to turn your iPAQ Pocket PC into a universal remote control. With the universal remote control, you can:

- Operate infrared supported office, entertainment, and home automation equipment
- Set up favorite channels
- Share the remote with others
- Create unique personal settings and profiles

Learn the Icons

The universal remote contains several icons that you tap to perform actions or access screens. For information on each of these icons, tap the **Question Mark** icon.

Use the Configuration Icons

You can use the configuration icons to customize, select user menus, or select rooms. The configuration icons are located at the bottom of the main **Nevo** screen.



To customize the home, screens, or favorites, tap the **Customize** icon. This allows additional customizing for controlling equipment in different rooms. You can add, edit, and delete devices and activities.



To specify user defined favorites or device settings, tap the **User** icon. You can add, edit, and delete user settings.



To select a device in a specific room, tap the **Room** icon. You can add, edit, and delete room assignments.

To change the functions when pressing the hard keys, tap the **KeyGuide** icon.

For information on other icons, tap the **Question Mark** icon.

Add a Device

You must add a device to the wheel before you can control it with the universal remote. You can set up the universal remote to control up to 12 devices in a room.

The universal remote comes pre-programmed with codes for thousands of infrared supported devices. You can download other codes from the Nevo Web site, <http://www.mynevo.com>.

You can automatically transfer all the remote control settings to your iPAQ Pocket PC.



The first time you use the universal remote, you will only see the **Add Devices** and **Add Activities** icons on the device wheel.

A wizard guides you through the process of adding a device. To exit the wizard at any time, tap the **Cancel** button. To return to the previous page, tap the **Back** button.

To add a device:

1. From the **Start** menu, tap **Nevo**.
2. Select one of the following:
 - a. Tap the **Add Device** icon.
 - b. Tap the **Wrench** icon, then **Add Device**.

3. Tap **Next**.



4. Tap the **Device** down arrow, select your device from the list, then tap **Next**.



5. Select the setup method.

| To identify your device by... | Then select... |
|---|--------------------------------------|
| Brand | By brand |
| Specific device number | By device ID |
| Searching through device numbers | By stepping through device IDs |
| Searching through models downloaded from MyNevo.com | By updating brands from the Web site |



It is recommended to search for your device by manufacturer's brand name.

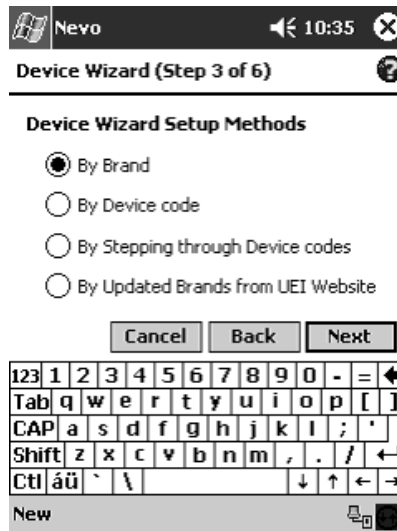

6. Tap **Next**.

7. Select specific device and device ID. The procedure varies depending upon the setup method selected in step 5.

For this example, we are selecting our device by Brand. Tap the **Brand** down arrow and select your brand.

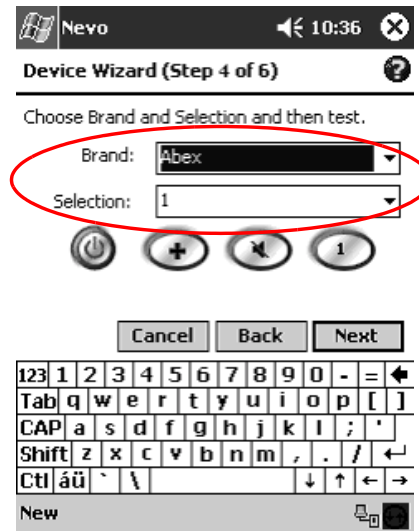

8. Tap the **Power** icon to test whether you can power on and off your device. If not, choose another code from the **Selection** list and repeat step 8.



9. Tap **Next**.

10. Enter a name for the device, then tap **Next**.



11. Select an icon for your device. The universal remote automatically assigns an icon to your device, but you can change it.

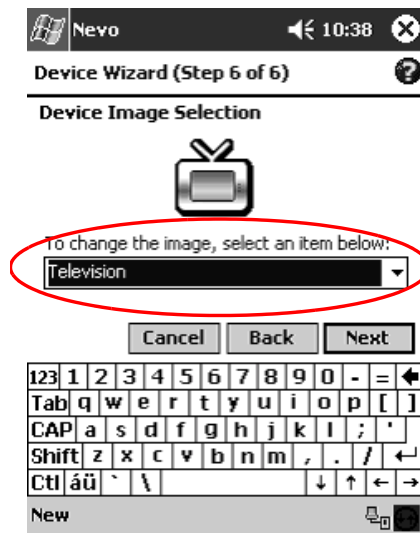

12. Tap **Next** to view your device on the wheel.

Change a Device

You can change the setup information for a device.

1. From the **Start** menu, tap **Nevo**.
2. Tap the **Room** icon, then select the room containing the device.
3. Tap the icon for the device on the wheel.
4. Tap the **Wrench** icon, then **Edit Device...**
5. Follow the on-screen instructions to make the changes.

Delete a Device

1. From the **Start** menu, tap **Nevo**.
2. Tap the device icon.
3. Tap the **Wrench** icon, then **Delete Device**.

Turn on a Device

1. From the **Start** menu, select **Nevo**.
You can choose **Start, Programs**, then **Nevo**.
2. Click a device on the wheel to position it at the top of the wheel.



3. Tap the **Power** button.

Add Activities

You can customize the keys on devices to switch activities. You can turn on more than one device at a time.

To add an activity:

1. Tap the **Room** icon to select where the devices are located.
2. Tap the **Add Activity** icon or tap the **Wrench** icon, then **Add Activity**.



3. Tap **Next**.

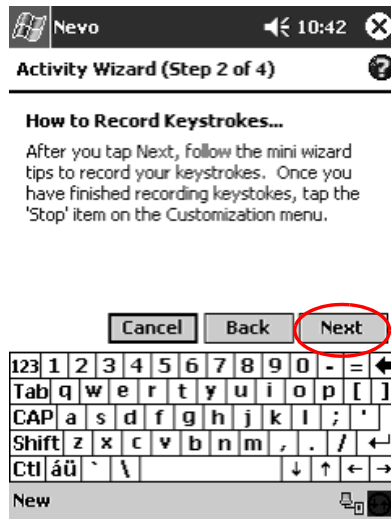

4. Tap **Next**.

5. Tap the icon for device you want to control.

6. Record the keystrokes for commanding multiple operations into one activity.



To command multiple devices, tap the **Home** icon, select another device, and follow the mini wizard to enter keystroke commands.

7. Tap the **Wrench** icon and select **Stop**.

8. Tap **Test** to test your keystrokes.

9. Tap **Finish Wizard**.

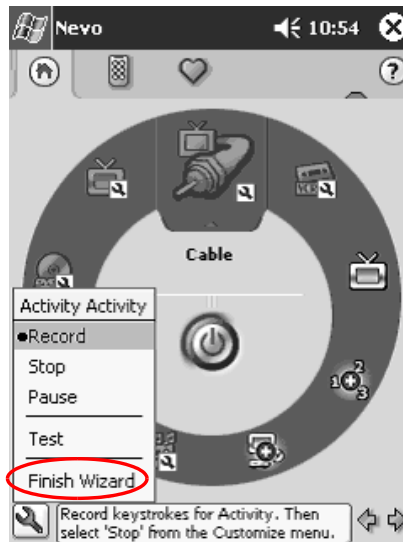

10. Assign a name to the activity, then tap **Next**.

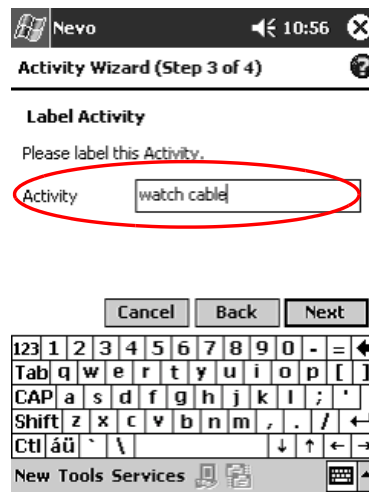

11. Assign an icon to the activity. Activities are designated in gold on the wheel.



12. Click **Next**.
13. Notice the activity on the wheel.



Change an Activity

You can change an activity assigned to a room.

1. From the **Start** menu, tap **Nevo**.
2. Tap the **Room** icon, then select the room for the activity.
3. Tap the icon for the activity.
4. Tap the **Wrench** icon, then **Edit Activity...**
5. Follow the wizard to make changes and enter keystrokes.



Make sure you check “Record a new sequence of keystrokes” if you want to change the input strokes.

6. Tap the **Wrench** icon, then **Stop**.
7. Tap the **Wrench** icon, then **Test**.
8. Tap the **Wrench** icon, then **Finish**.

Assign a new name to your favorite channel.

Delete an Activity

1. From the **Start** menu, tap **Nevo**.
2. Tap the activity icon.
3. Tap the **Wrench** icon, then **Delete Activity**.

Set Up a Room

You can program the universal remote to control devices in each room.

To set up a room:

1. From the **Start** menu, tap **Nevo**.
2. Tap the **Room** icon, then **Add Room**.
3. Select a region from **Regions** down arrow list.
4. Tap **Next**.
5. Type a label for the room, then tap **Next**.
6. Assign an icon to the room.

Add a Device to a Room

You must set up a room before you can assign a device to it. For more information on setting up a room, see section “To set up a room.”

1. From the **Start** menu, tap **Nevo**.
2. Tap the **Room** icon.
3. Select a room.
4. Tap the **Add Devices** icon to start the Device wizard.
5. Add the device to your room.

Delete a Room

1. From the **Start** menu, tap **Nevo**.
2. Tap the **Room** icon, then select the room to delete.
3. Tap the **Room** icon again, then **Delete Room**.

Add a Favorite Channel

You can add a favorite channel to your device.



Tap the **Channel** icon to modify a channel setup. If you have multiple pages of favorites, tap the **Right** and **Left** arrow icons to scroll through the pages.

To add a favorite:

1. From the **Start** menu, tap **Nevo**.
2. Tap the **Wrench** icon, then **Add Favorite**.
3. Follow the on-screen instructions of the wizard.
4. Tap the **Home Page** icon.
5. Tap the device for the channel selection control.
6. Tap the correct key sequence for the channel.



If the device requires you press **Enter**, then include **Enter** in the key sequence.

7. Tap the **Wrench** icon, then **Stop**.
8. Tap the **Wrench** icon, then **Test**.
9. Tap the **Wrench** icon, then **Finish**.
10. Assign a name to your favorite channel.
11. Tap the **Wrench** icon, then select **Add Page**.

Change a Favorite

You can change a stored favorite channel.

1. From the **Start** menu, tap **Nevo**.
2. Tap the **Favorites** icon, then select the favorite to change.

3. Tap the **Wrench** icon, then **Edit Favorite...**
4. Follow the wizard to make changes.



Make sure you check “Record a new sequence of keystrokes” if you want to change the input strokes.

5. Tap the **Wrench** icon, then **Stop**.
6. Tap the **Wrench** icon, then **Test**.
7. Tap the **Wrench** icon, then **Finish**.
8. Assign a new name to your favorite channel.

Set Up User Profile

You can set up multiple users for the universal remote. Each user can have his/her own personal preferences and favorites.

To set up a user profile:

1. From the **Start** menu, tap **Nevo**.
2. Tap the **User** icon, the **Add User**.
3. Type a name for the user.

Change a User Profile

You can change user information.

1. From the **Start** menu, tap **Nevo**.
2. Tap the **User** icon, the **Edit User**.
3. Type a name for the user.

Download Device Codes and Key Functions

You can download setup codes and key functions from MyNevo.com. You must register at <http://www.MyNevo.com> to download information. The registration process requires your iPAQ Pocket PC's serial number and library code.

Download Device Codes

It is recommended that you follow the instructions on MyNevo.com's device download center.

1. Establish a partnership between your iPAQ Pocket PC and your personal computer (see Chapter 1 for more information).
2. From your personal computer, go to <http://www.MyNevo.com>.
3. Follow the instructions on the web site to select the device to download.
4. Synchronize your personal computer with the iPAQ Pocket PC.
5. Tap the **Add Device** icon.
6. Tap the device you downloaded from the **By Brand** down arrow list.
7. Follow the wizard.

Download Key Functions

It is recommended that you follow the instructions on MyNevo.com's device advanced key functions download center.

1. Establish a partnership between your iPAQ Pocket PC and your personal computer (see Chapter 1 for more information).
2. From your personal computer, go to <http://www.MyNevo.com>.
3. Follow the instructions on the web site to select the device keys to download.
4. Synchronize your personal computer with the iPAQ Pocket PC.
5. Open a key wizard.
6. Tap the keys you downloaded from the **Function** down arrow list.
7. Follow the wizard.

Work with Function Keys

You can add, edit, and learn functions for the universal remote.

Add Function Keys

1. From the **Start** menu, tap **Nevo**.
2. Tap the **Wrench** icon, then **Add Key**.
3. Follow the on-screen instructions.

Edit Function Keys

1. From the **Start** menu, tap **Nevo**.

2. Tap the **Wrench** icon, then **Edit Key**.
3. Follow the on-screen instructions.

Learn Function Keys

1. From the **Start** menu, tap **Nevo**.
2. Tap the **Room** icon, then select the room with the device to use the function keys.
3. Tap the activity on the wheel, then the **Keypad** icon.
4. Tap the **Wrench** icon, then **Express Learning**.
5. Follow the on-screen instructions.

Copy Function Keys

1. From the **Start** menu, tap **Nevo**.
2. Tap the **Wrench** icon, then **Copy Key**.
3. Follow the on-screen instructions.

Move Function Keys

1. From the **Start** menu, tap **Nevo**.
2. Tap the **Wrench** icon, then **Move Key**.
3. Follow the on-screen instructions.

Delete Function Keys

1. From the **Start** menu, tap **Nevo**.
2. Tap the **Wrench** icon, then **Delete Key**.
3. Follow the on-screen instructions.

Regulatory Notices

Federal Communications Commission Notice

This equipment has been tested and found to comply with the limits for a Class B digital device, pursuant to Part 15 of the FCC Rules. These limits are designed to provide reasonable protection against harmful interference in a residential installation. This equipment generates, uses, and can radiate radio frequency energy and, if not installed and used in accordance with the instructions, may cause harmful interference to radio communications. However, there is no guarantee that interference will not occur in a particular installation. If this equipment does cause harmful interference to radio or television reception, which can be determined by turning the equipment off and on, the user is encouraged to try to correct the interference by 1 or more of the following measures:

- Reorient or relocate the receiving antenna
- Increase the separation between the equipment and receiver
- Connect the equipment into an outlet on a circuit different from that to which the receiver is connected
- Consult the dealer or an experienced radio or television technician for help

Modifications

The FCC requires the user to be notified that any changes or modifications made to this device that are not expressly approved by HP Computer Corporation may void the Reference authority to operate the equipment.

Cables

Connections to this device must be made with shielded cables with metallic RFI/EMI connector hoods in order to maintain compliance with FCC Rules and Regulations.

Declaration of Conformity for Products Marked with the FCC Logo—United States Only

This device complies with Part 15 of the FCC Rules. Operation is subject to the following two conditions: (1) this device may not cause harmful interference, and (2) this device must accept any interference received, including interference that may cause undesired operation.

For questions regarding your product, contact:

HP Computer Corporation
P. O. Box 692000, Mail Stop 530113
Houston, Texas 77269-2000

Or, call 1-800-652-6672 (1-800-OK HP)

For questions regarding this FCC declaration, contact:

HP Computer Corporation
P. O. Box 692000, Mail Stop 510101
Houston, Texas 77269-2000
Or, call (281) 514-3333

To identify this product, refer to the Part, Series, or Model number found on the product.

Canadian Notice

This Class B digital apparatus meets all requirements of the Canadian Interference-Causing Equipment Regulations.

Avis Canadien

Cet appareil numérique de la classe B respecte toutes les exigences du Règlement sur le matériel brouilleur du Canada.

Japanese Notice

この装置は、情報処理装置等電波障害自主規制協議会（VCCI）の基準に基づくクラス B 情報技術装置です。この装置は、家庭環境で使用することを目的としていますが、この装置がラジオやテレビジョン受信機に近接して用されると、受信障害を引き起こすことがあります。取扱説明書に従って正しい取り扱いをして下さい。

Battery Warning



CAUTION: Danger of explosion if battery is incorrectly replaced. Replace with only the same or equivalent type recommended by the manufacturer. Dispose of used batteries according to the manufacturer's instructions.



WARNING: This computer contains an internal lithium polymer battery pack. To reduce the risk of fire or burns, do not disassemble, crush, puncture, short external contacts, or dispose of in fire or water. Replacement should only be done by a HP authorized service provider using the HP spare part for this computer.

Airline Travel Notice

Use of electronic equipment aboard commercial aircraft is at the discretion of the airline.

Wireless Notices

In some environments, the use of wireless devices may be restricted. Such restrictions may apply aboard airplanes, in hospitals, near explosives, in hazardous locations, etc. If you are uncertain of the policy that applies to the use of this device, please ask for authorization to use it prior to turning it on.

U.S. Regulatory Wireless Notice

This product emits radio frequency energy, but the radiated output power of this device is far below the FCC radio frequency exposure limits. Nevertheless, the device should be used in such a manner that the potential for human contact with the antenna during normal operation is minimized.

Canadian Regulatory Wireless Notice

Operation is subject to the following two conditions: (1) this device may not cause interference, and (2) this device must accept any interference, including interference that may cause undesired operation of the device.

To prevent radio interference to the licensed service, this device is intended to be operated indoors and away from windows to provide maximum shielding. Equipment (or its transmit antenna) that is installed outdoors is subject to licensing.

The term “IC:” before the certification/registration number only signifies that the Industry Canada technical specifications were met.

European Union Notice



Products bearing the CE marking comply with the R&TTE Directive (1999/5/EC), EMC Directive (89/336/EEC), and the Low Voltage Directive (73/23/EEC) issued by the Commission of the European Community.

Compliance with these directives implies conformity to the following European Norms (in parentheses are the equivalent international standards and regulations):

- EN 55022 (CISPR 22)—Electromagnetic Interference
- EN 55024 (IEC61000-4-2, 3, 4, 5, 6, 8, 11)—Electromagnetic Immunity
- EN61000-3-2 (IEC61000-3-2)—Power Line Harmonics
- EN61000-3-3 (IEC61000-3-3)—Power Line Flicker

- EN 60950 (IEC 60950)—Product Safety
- EN 300 328—Technical requirements for radio equipment
- ETS 300 826 or EN 301 489-17—General EMC requirements for radio equipment

This product may be used in all EU and EFTA countries.

Japanese Notice

この機器の使用周波数帯では、電子レンジ等の産業・科学・医療用機器のほか工場の製造ライン等で使用されている移動体識別用の構内無線局（免許を要する無線局）及び特定小電力無線局（免許を要しない無線局）が運用されています。

- 1 この機器を使用する前に、近くで移動体識別用の構内無線局及び特定小電力無線局が運用されていないことを確認して下さい。
- 2 万一、この機器から移動体識別用の構内無線局に対して電波干渉の事例が発生した場合には、速やかに使用周波数を変更するか又は電波の発射を停止した上、下記連絡先にご連絡頂き、混信回避のための処置等（例えば、パーティションの設置など）についてご相談して下さい。
- 3 その他、この機器から移動体識別用の特定小電力無線局に対して電波干渉の事例が発生した場合など何かお困りのことが起きたときは、次の連絡先へお問い合わせ下さい。

連絡先：コンパクトコンピュータ株式会社 TEL：0120-101589



Brazilian Regulatory Wireless Notice

Este equipamento opera em caráter secundário, isto é, não tem direito a proteção contra interferência prejudicial, mesmo de estações do mesmo tipo, e não pode causar interferência a sistemas operando em caráter primário.



WARNING: To reduce the risk of personal injury, electric shock, fire, or damage to the equipment, plug the AC Adapter into an electrical outlet that is easily accessible at all times. Disconnect power from the equipment by unplugging the AC Adapter from the electrical outlet. Do not place anything on power cords or cables. Arrange them so that no one may accidentally step on or trip over them.

Hardware Specifications

System Specifications

Specifications

| System Feature | hp iPAQ h5400 Series |
|-----------------------|-----------------------------|
|-----------------------|-----------------------------|

| | |
|-----------|------------------------|
| Processor | Intel PXA250 (400 MHz) |
|-----------|------------------------|

| | |
|--------|------------------------|
| Memory | 64 MB SDRAM or greater |
|--------|------------------------|

| | |
|-----|------------------|
| ROM | 32 MB or greater |
|-----|------------------|

| | |
|------------|----------------------------|
| SD Storage | Memory card and SDIO ready |
|------------|----------------------------|

| | |
|---------|--|
| Display | Transflective color TFT, 240 x 320 pixels, 64Kcolor support, .24-dot pitch |
|---------|--|

| | |
|---------------|--|
| LED Backlight | Multi-level brightness adjustment, light sensor for automatic adjustment of brightness level |
|---------------|--|

| | |
|-------|--|
| Audio | Speaker, 3.5 mm stereo headphone and microphone jack |
|-------|--|

| | |
|----------|--|
| Infrared | IrDA, data transfer up to 115.2 Kb per second and Universal Remote Control for control of home entertainment units |
|----------|--|

| | |
|-----------|-------------|
| Bluetooth | Some models |
|-----------|-------------|

| | |
|--------------------|--------------------------|
| Fingerprint Reader | Thermal swipe technology |
|--------------------|--------------------------|

Specifications (Continued)

| System Feature | hp iPAQ h5400 Series |
|-----------------------|--|
| Communications | Communication port, Expansion Pack connector |
| Indicators | 3-mode alarm notification: Flashing green LED, tone, pop-up message Chargeactive: flashing/solid amber LED Bluetooth active: flashing/solid blue LED WLAN active: flashing green LED WLAN enabled but not connected: flashing amber LED |
| Battery | Removable/rechargeable Lithium Polymer with internal memory backup battery |

Physical Specifications

hp iPAQ Pocket PC h5400 Series

| | US | Metric |
|--|-----------------------|-----------------------|
| Length of the unit (without WLAN antenna) | 5.23 in | 133.0 mm |
| Length of the unit (with LAN antenna) | 5.43 in | 138.0 mm |
| Width | 3.30–3.03 in tapering | 84.0–77.0 mm tapering |
| Depth | 0.63 in | 15.9 mm |
| Weight | 7.26 oz | 206 gm |

Operating Environment

Environment

| | | US | Metric |
|-------------------|--------------|----------------|-------------------|
| Temperature | Operating | 32° to 104° F | 0° to 40° C |
| | Nonoperating | -22° to 140° F | -30-° to 60° C |
| Relative Humidity | Operating | 10 to 90% | 10 to 90% |
| | Nonoperating | 10 to 90% | 10 to 90% |
| Maximum Altitude | Operating | 0–15,000 ft | 14.7 to 10.1 psia |
| | Nonoperating | 0–15,000 ft | 14.7 to 10.1 psia |

Index

A

- AC Adapter 2–36
- ActiveSync
 - back up Pocket PC 2–26
 - connect to computer 6–1
 - restore Pocket PC memory 2–26
- application buttons
 - customize 2–43
- applications
 - close 2–41
 - install 2–43
 - open 2–40
- appointments
 - categorize 8–10
 - delete 8–10
 - schedule 8–9
- AvantGo 6–2

B

- back up Pocket PC 2–26
- backlight 2–15
- Block Recognizer 2–8

C

- Calendar 8–6
- charging the Pocket PC 2–36
- connect
 - to the Internet 6–8
 - to your network 6–8

- contacts 7–1
 - categorize 7–3
 - create 7–2
 - delete 7–6
 - edit 7–2
 - view 7–2
- convert writing to text 2–10
- customer support 1–2
- customize
 - application buttons 2–43
 - Calendar appearance 8–8

D

- date
 - set 2–14
- delete
 - eBook 9–13
- draw on screen 2–9

E

- eBook
 - annotate 9–14
 - copy 9–12
 - delete 9–13
 - listen to 9–14
 - read 9–11
- e-mail
 - delete 7–14
 - manage folders 7–16
 - open 7–13
 - receive 7–12

e-mail service, set up 7–8
enter information 2–1

F

files, move to, from computer 6–6
folders 7–16

I

Inbox 7–7
infrared connection
 connect computer 6–1
install
 applications 2–43

K

keyboard 2–4

L

Letter Recognizer 2–6
link to Web sites 6–10

M

Microsoft Reader 9–10
 copy ebooks 9–12
 delete eBook 9–13

N

network, connect 6–8
notes
 write 7–19

O

onscreen keyboard 2–4
options, change
 Microsoft Reader 9–15
 Word 9–4
 word suggestions 2–2

P

Pocket Excel 9–6
Pocket Word 9–1

R

record
 voice 7–17
registration 1–10
reminders, set 8–9, 8–13
restore memory 2–26

S

set
 date 2–14
 time, home 2–11
 time, visiting location 2–13
support 1–2
synchronization, change settings
 6–4
synchronize
 Excel workbooks 9–6
 links to Web sites 6–10
 with your computer 6–2
 Word documents 9–1

T

tasks 8–13
time
 set for home 2–11
 set for visiting location 2–13
Today screen 8–1
Transcriber 2–8

U

universal cradle 2–36

V

view

 contacts 7-2

voice

 recording 7-17

W

Web sites

 synchronize links 6-10

Windows Explorer 6-6

Word 9-1

word suggestions, change options
 2-2

write on screen 2-9

writing, convert to text 2-10