



FCC CFR47 CERTIFICATION

PART 22H

TEST REPORT

FOR

SINGLE BAND, SINGLE MODE CDMA MOBILE PHONE

MODEL: LG-PD820

FCC ID: BEJPD820

REPORT NUMBER: 04I2757-1

ISSUE DATE: JUNE 10, 2004

Prepared for

LG ELECTRONICS

459-9, KASAN-DONG, KUMCHON-GU

SEOUL, SOUTH KOREA 153-023

Prepared by

COMPLIANCE CERTIFICATION SERVICES

561F MONTEREY ROAD, ROUTE 2

MORGAN HILL, CA 95037, USA

TEL: (408) 463-0885

FAX: (408) 463-0888

TABLE OF CONTENT

1. TEST RESULT CERTIFICATION	3
2. EUT DESCRIPTION	4
3. TEST METHODOLOGY	4
4. TEST FACILITY	4
5. ACCREDITATION AND LISTING	4
6. MEASURING INSTRUMENT CALIBRATION	4
7. TEST SETUP, PROCEDURE AND RESULT	5
7.1. SECTION 2.1046: RF POWER OUTPUT	5
7.2. SECTION 2.1047: MODULATION CHARACTERISTICS	10
7.3. SECTION 2.1049: OCCUPIED BANDWIDTH	10
7.4. SECTION 2.1051: SPURIOUS EMISSION AT ANTENNA TERMINAL	15
7.5. SECTION 2.1053: FIELD STRENGTH OF SPURIOUS RADIATION	22
7.6. SECTION 2.1055: FREQUENCY STABILITY	26
8. APENDIX	29
8.1. EXTERNAL & INTERNAL PHOTOS	29
8.2. SCHEMATICS	29
8.3. BLOCK DIAGRAM.....	29
8.4. USER MANUAL.....	29

1. TEST RESULT CERTIFICATION

COMPANY NAME: LG ELECTRONICS
459-9, KASAN-DONG, KUMCHON-GU
SEOUL, SOUTH KOREA 153-023

EUT DESCRIPTION: SINGLE BAND, SINGLE MODE CDMA MOBILE PHONE

MODEM NAME: LG-PD820

DATE TESTED: MAY 28 – JUN 01, 2004

TYPE OF EQUIPMENT	INTENTIONAL RADIATOR
EQUIPMENT TYPE	LICENSED TX MODULE IN MOBILE APPLICATION
MEASUREMENT PROCEDURE	ANSI 63.4 / 2001, TIA/EIA 603
PROCEDURE	CERTIFICATION
FCC RULE	CFR 47 PART 22 Subpart H

Compliance Certification Services, Inc. tested the above equipment for compliance with the requirement set forth in CFR 47, PART 22 Subpart H-Cellular Radiotelephone Service. The equipment in the configuration described in this report, shows the measured emission levels emanating from the equipment do not exceed the specified limit.

Note: This document reports conditions under which testing was conducted and results of tests performed. This document may not be altered or revised in any way unless done so by Compliance Certification Services and all revisions are duly noted in the revisions section. Any alteration of this document not carried out by Compliance Certification Services will constitute fraud and shall nullify the document.

Tested By:



VIEN TRAN
EMC TECHCIAN
COMPLIANCE CERTIFICATION SERVICES

Released For CCS By:



THU CHAN
EMC SUPERVISOR
COMPLIANCE CERTIFICATION SERVICES

2. EUT DESCRIPTION

The Single Band, Single Mode Cellular Phone has an output power 24.80dBm / 302mW (CDMA, ERP). It has a fixed type (Helical) antenna, which is designed for the Cellular band transmitting of frequency range 824 ~ 849MHz.

3. TEST METHODOLOGY

Both conducted and radiated testing were performed according to the procedures documented on chapter 13 of ANSI C63.4 and FCC CFR 47 2.1046, 2.1047, 2.1049, 2.1051, 2.1053, 2.1055 and 2.1057.

4. TEST FACILITY

The open area test sites and conducted measurement facilities used to collect the radiated data are located at 561F Monterey Road, Morgan Hill, California, USA. The sites are constructed in conformance with the requirements of ANSI C63.7, ANSI C63.4 and CISPR Publication 22.

5. ACCREDITATION AND LISTING

The test facilities used to perform radiated and conducted emissions tests are accredited by National Voluntary Laboratory Accreditation Program for the specific scope of accreditation under Lab Code: 200065-0 to perform Electromagnetic Interference tests according to FCC PART 15 AND CISPR 22 requirements. No part of this report may be used to claim or imply product endorsement by NVLAP or any agency of the US Government. In addition, the test facilities are listed with Federal Communications Commission (reference no: 31040/SIT (1300B3) and 31040/SIT (1300F2))

6. MEASURING INSTRUMENT CALIBRATION

The measuring equipment, which was utilized in performing the tests documented herein, has been calibrated in accordance with the manufacturer's recommendations for utilizing calibration equipment, which is traceable to recognized national standards.

7. TEST SETUP, PROCEDURE AND RESULT

7.1. SECTION 2.1046: RF POWER OUTPUT

INSTRUMENTS LIST

EQUIPMENT	MANUFACTURE	MODEL NO.	CAL. DUE DATE
Spectrum Analyzer	Agilent	E4446A	6/11/04
RF Synthesizer	HP	83732B	4/4/05
Attenuator	MINI CIRCUITS	MCL BW-S10W2	N/A
Amplifier	MITEQ	NSP2600-44	4/25/05
LP Antenna	EMCO	3146	3/6/05
Horn Antenna	EMCO	3115 SN: 2238	2/4/05
Horn Antenna	EMCO	3115 SN: 3245	2/4/05
Adjustable Dipole	EMC Test Systems	3121C	5/26/05

MEASUREMENT PROCEDURE

- 1). On a test site, the EUT shall be placed on a turntable, and in the position closest to the normal use as declared by the user.
- 2). The test antenna shall be oriented initially for vertical polarization located 3m from the EUT to correspond to the frequency of the transmitter.
- 3). The output of the test antenna shall be connected to the measuring receiver and either a peak or quasi-peak detector was used for the measurement as indicated on the report. The detector selection is based on how close the emission level was approaching the limit.
- 4). The transmitter shall be placed 0.80 meter above the ground plane, the X, Y, and Z positions shall be tested and the worst case reported. The transmitter shall be switched on with typical modulation and the measurement receiver shall be tuned to the frequency of the transmitter under test.
- 5). The test antenna shall be raised and lowered through the specified range of height until the measuring receiver detects a maximum signal level.
- 6). The transmitter shall then be rotated through 360° in the horizontal plane, until the maximum signal level is detected by the measuring receiver.
- 7). The test antenna shall be raised and lowered again through the specified range of height until a maximum signal level is detected by the measuring receiver.
- 8). The maximum signal level detected by the measuring receiver shall be noted.
- 9). The transmitter shall be replaced by a tuned dipole / horn (substitution antenna).

10). The substitution antenna shall be oriented for vertical polarization and the length of the substitution antenna shall be adjusted to correspond to the frequency of the transmitter.

11). The substitution antenna shall be connected to a calibrated signal generator.

12). If necessary, the input attenuator setting of the measuring receiver shall be adjusted in order to increase the sensitivity of the measuring receiver.

13). The test antenna shall be raised and lowered through the specified range of the height to ensure that the maximum signal is received.

14). The input signal to the substitution antenna shall be adjusted to the level that produces a level detected by the measuring receiver, that is equal to the level noted while the transmitter radiated power was measured, corrected for the change of input attenuation setting of the measuring receiver.

15). The input level to the substitution antenna shall be recorded as power level in dBm, corrected for any change of input attenuator setting of the measuring receiver.

16). The measurement shall be repeated with the test antenna and the substitution antenna oriented for horizontal polarization.

17). The measure of the effective radiated power is the larger of the two levels recorded, at the input to the substitution antenna, corrected for the gain of the substitution antenna if necessary.

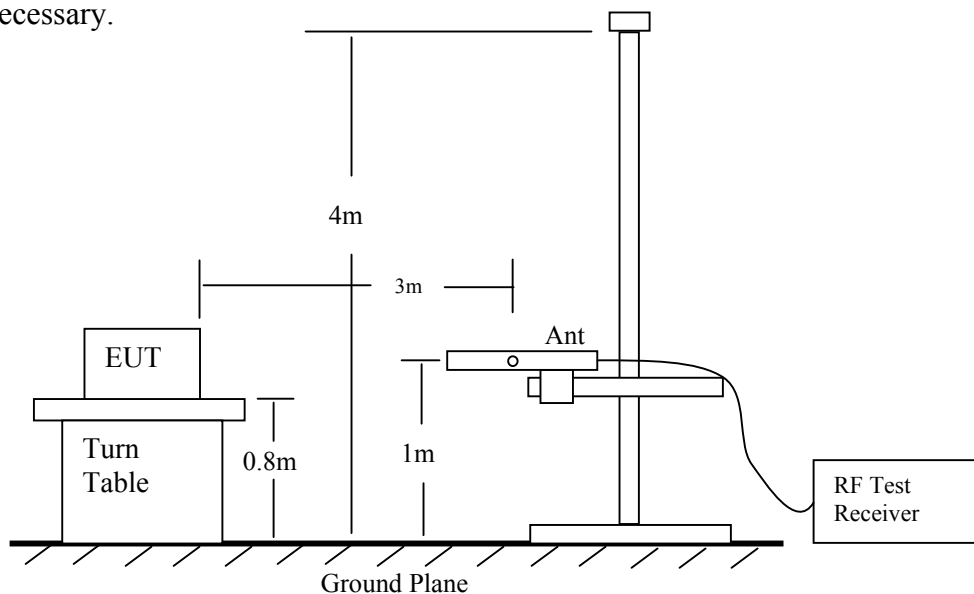

Radiated Emission Measurement 30 to 1000 MHz

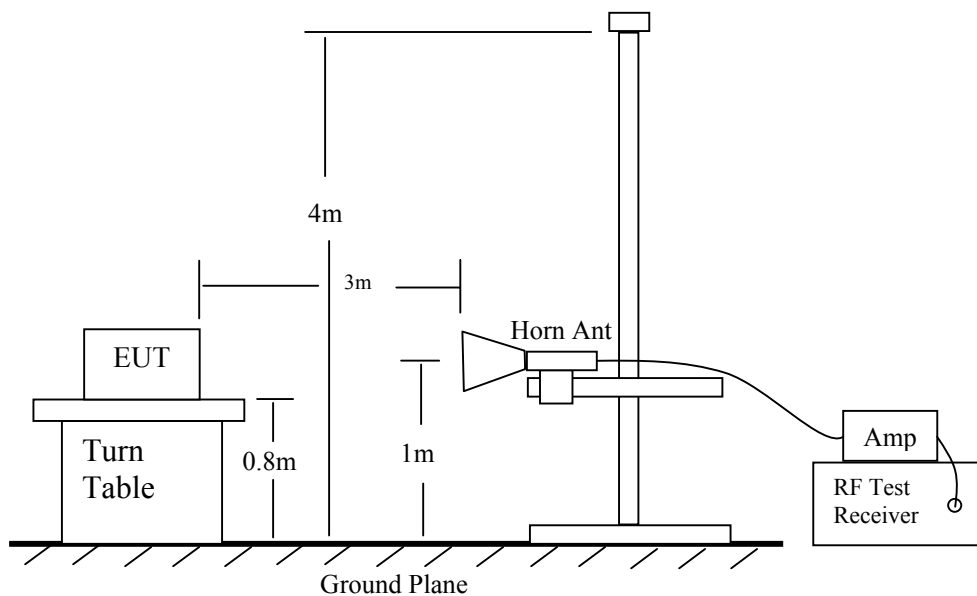

Radiated Emission Above 1000 MHz

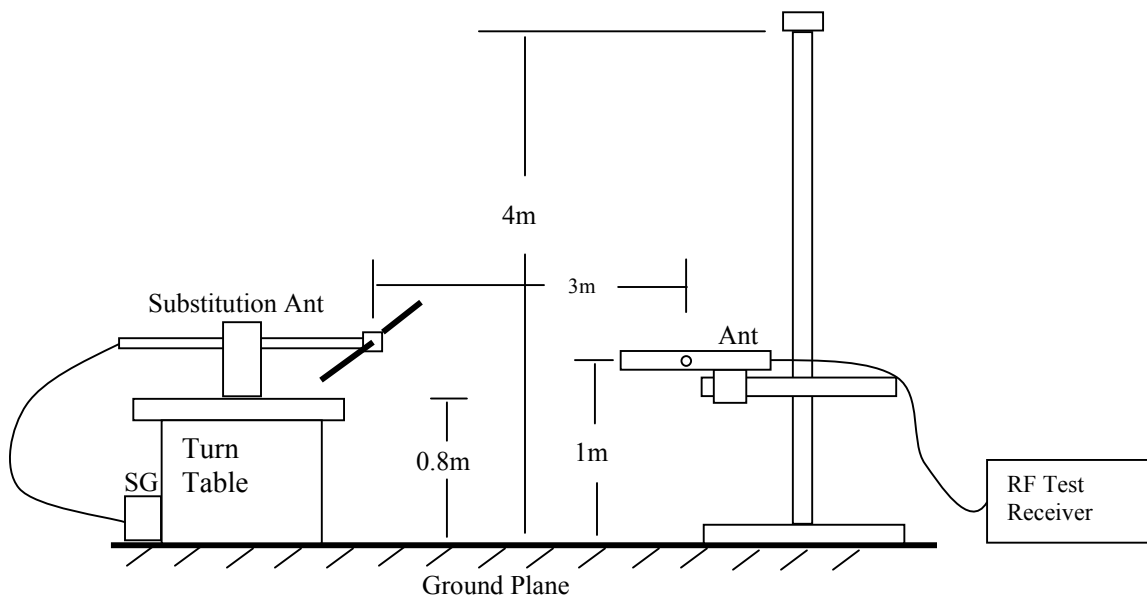

Radiated Emission – Substitution Method

X position:

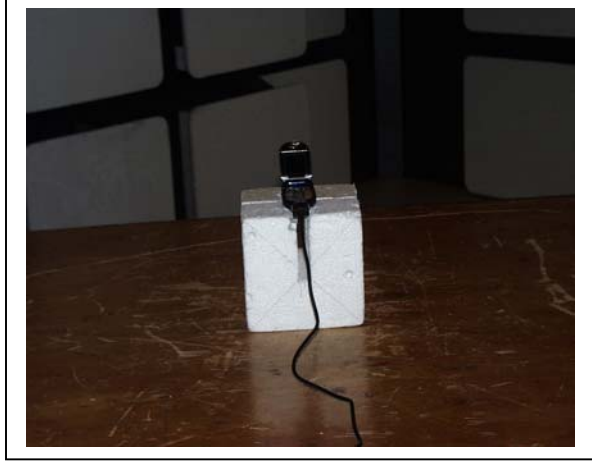

Y position:



Z position:

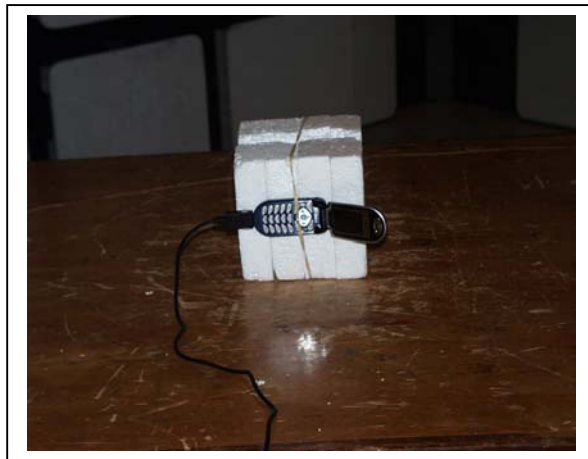

Test result:

Company Name: LG Electronics
 Project No.: 04i2757-1
 EUT Description: Single-Band,Single Mode CDMA Cellular Phone

CDMA

	Ch.#	Freq. (MHz)	Average Power Meter (dBm)	Output Power ERP (dBm)	AGC
Low Ch.	1017	824.82	25.43	24.10	345.00
Mid Ch.	383	836.49	25.40	24.80	345.00
High Ch.	772	848.19	25.10	24.70	352.00

RF Cable 0.5

CDMA Output Power (ERP):

f GHz	SA reading (dBuV)	SG reading (dBm)	CL (dB)	Gain (dBi)	Gain (dBd)	ERP (dBm)	Limit (dBm)	Margin (dB)	Notes
0.825	94.6	26.7	0.5	0.0	-2.2	24.1	38.5	-14.4	V, Y-position
0.825	94.0	25.6	0.5	0.0	-2.2	23.0	38.5	-15.5	H, Y-position
0.836	95.0	27.5	0.5	0.0	-2.2	24.8	38.5	-13.7	V, Y-position
0.836	92.7	21.7	0.5	0.0	-2.2	19.0	38.5	-19.5	H, Y-position
0.848	94.9	27.4	0.5	0.0	-2.2	24.7	38.5	-13.8	V, Y-position
0.848	93.7	22.7	0.5	0.0	-2.2	20.0	38.5	-18.5	H, Y-position

Note: RBW=VBW=3MHz

7.2. SECTION 2.1047: MODULATION CHARACTERISTICS

Not applicable, the EUT is single mode CDMA only.

7.3. SECTION 2.1049: OCCUPIED BANDWIDTH

SETUP CONFIGURATION

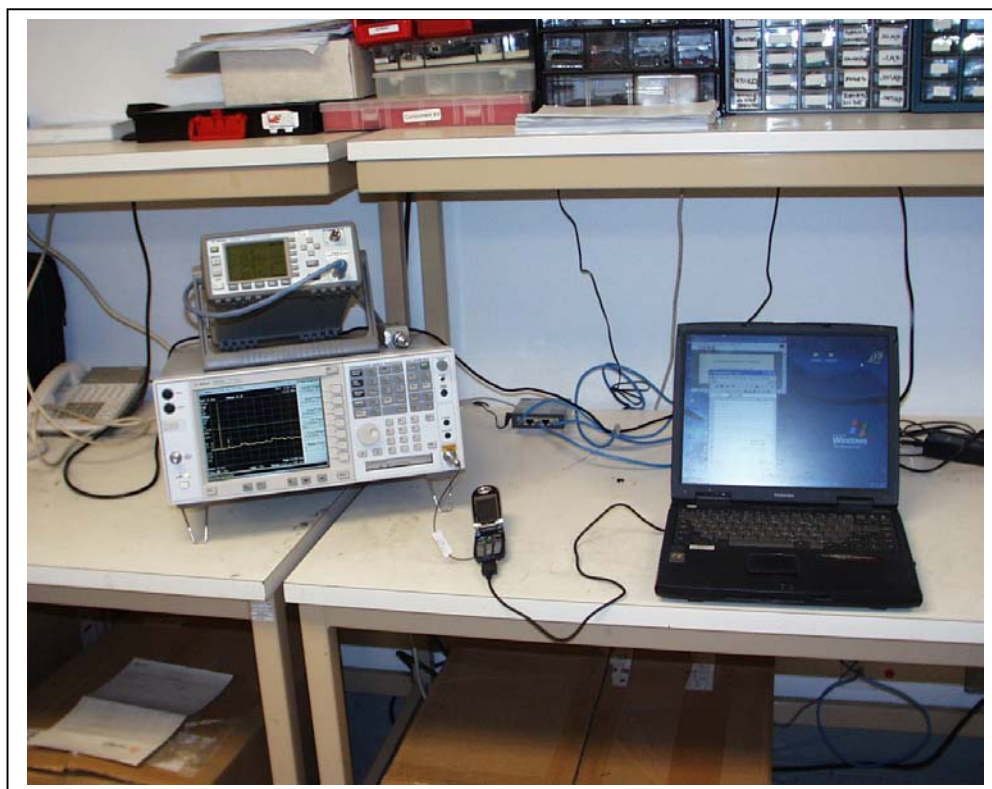
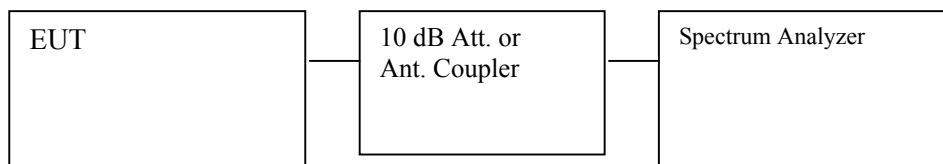

INSTRUMENTS LIST

EQUIPMENT	MANUFACTURE	MODEL NO.	CAL. DUE DATE
Spectrum Analyzer 20 Hz ~ 44 GHz	Agilent	E4446A	6/11/04
Attenuator	MINI CIRCUITS	MCL BW-S10W2	N/A

TEST PROCEDURE

The transmitter output is connected to the spectrum analyzer. The RBW is set to 1% of the Emission bandwidth. The VBW is set to 3 times the RBW. The sweep time is coupled.

RESULTS

No non-compliance noted:

Channel	Frequency (MHz)	26dB BW (MHz)
Low	824.82	1.425
Middle	836.49	1.403
High	848.19	1.424

26dB BANDWIDTH (Low Channel)

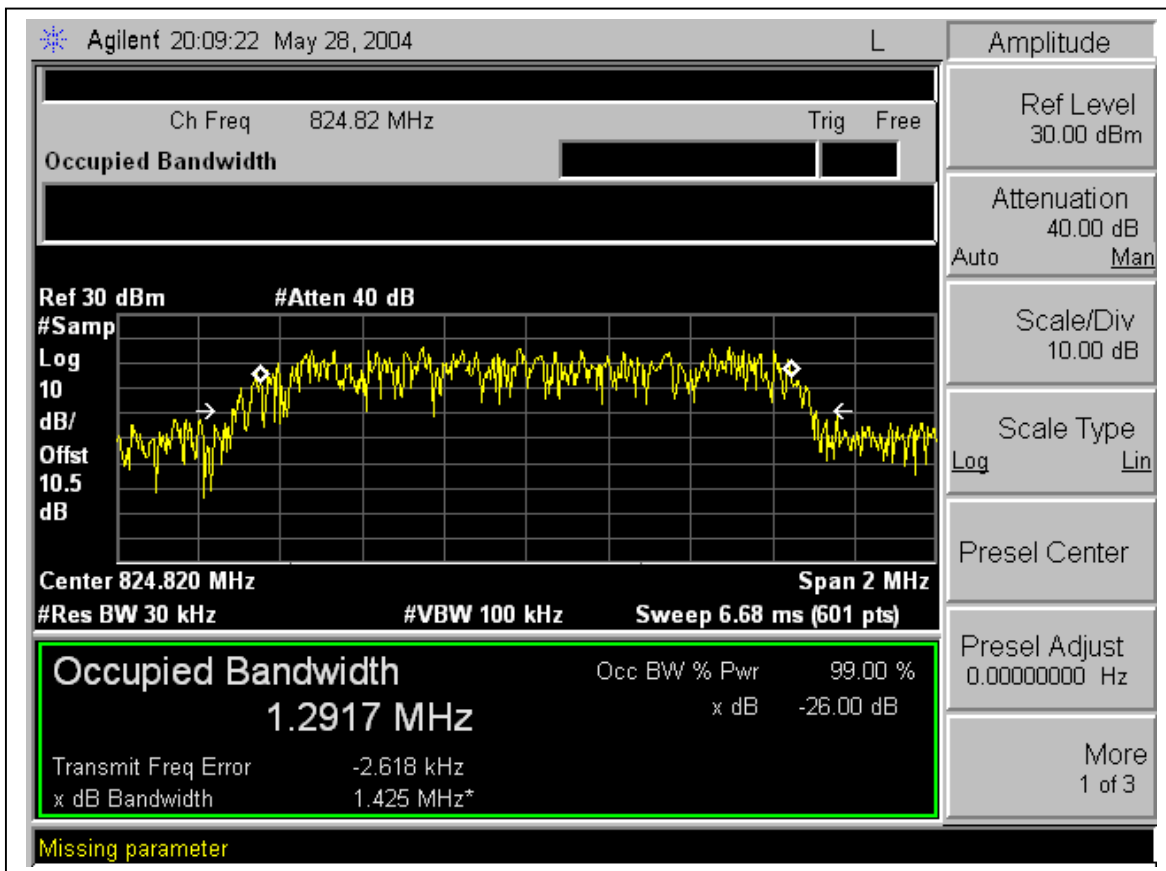

26dB BANDWIDTH (Mid Channel)

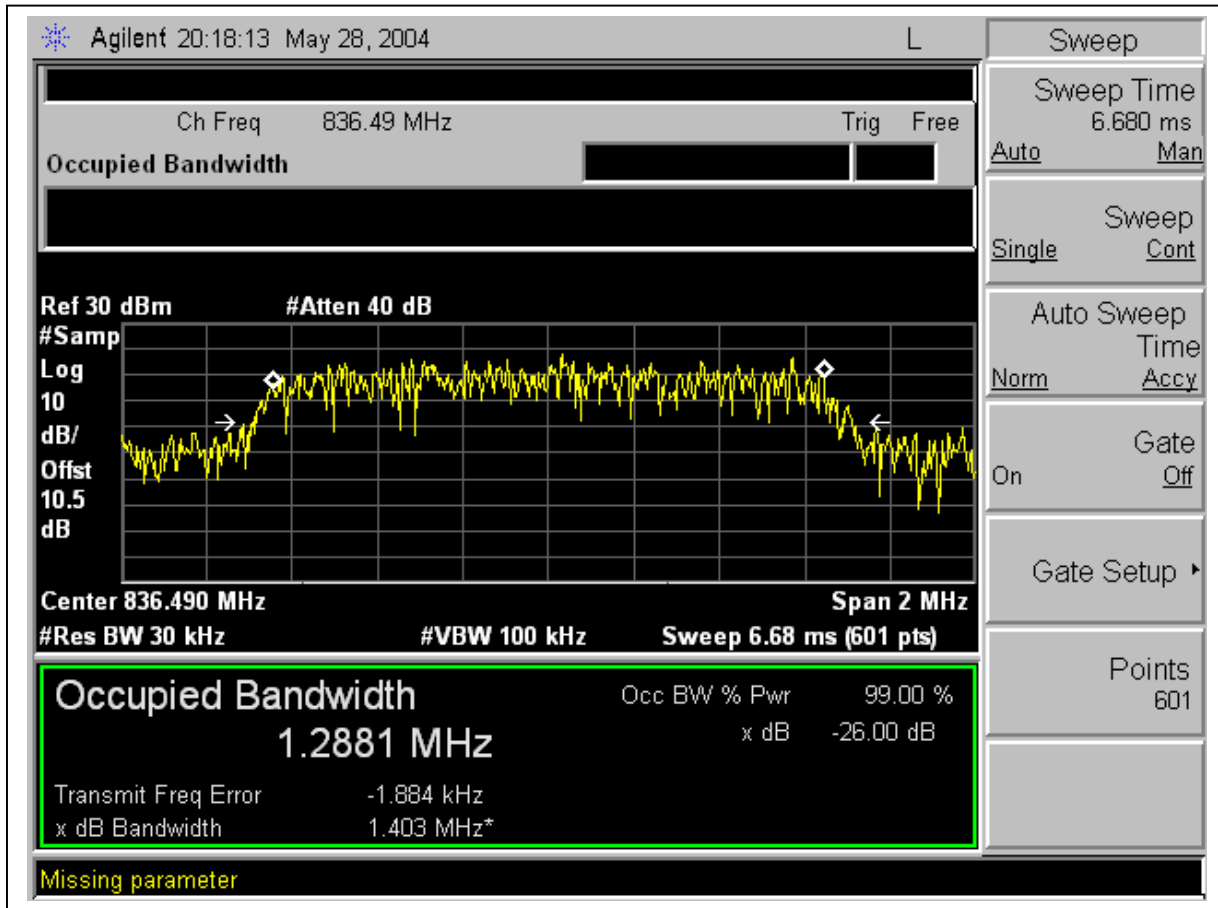

26dB BANDWIDTH (High Channel)

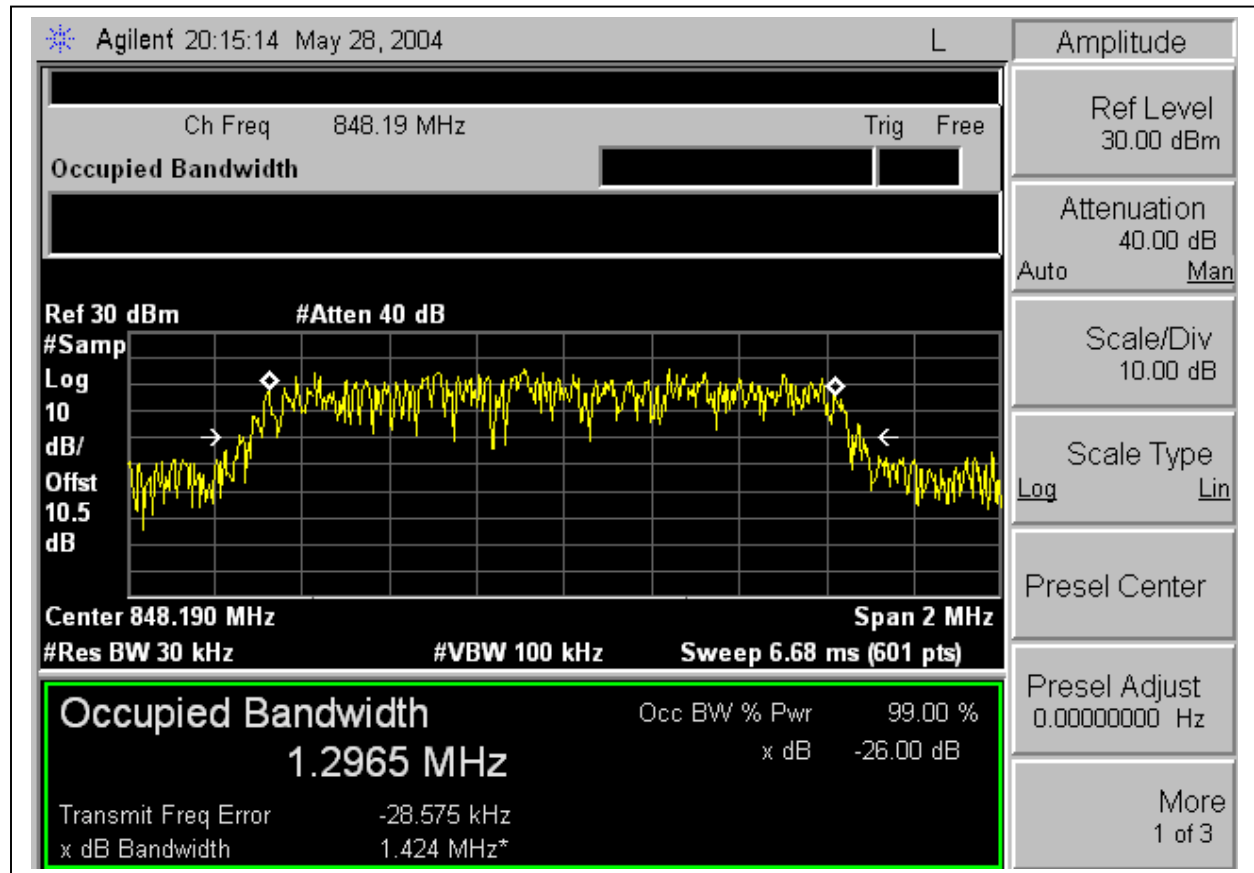

7.4. SECTION 2.1051: SPURIOUS EMISSION AT ANTENNA TERMINAL

INSTRUMENTS LIST

EQUIPMENT	MANUFACTURE	MODEL NO.	CAL. DUE DATE
Spectrum Analyzer 20 Hz ~ 44 GHz	Agilent	E4446A	6/11/04
Attenuator	MINI CIRCUITS	MCL BW-S10W2	N/A

TEST SETUP

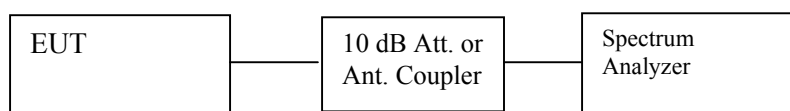

TEST PROCEDURE

- 1) EUT's RF output connector (made solely for the purpose of the test) is connected to the spectrum analyzer, and set as close as possible to the bottom of the block edge and one set as close as possible to the top of the block edge. Set the RES BW to 1% of the emission bandwidth to show compliance with the -13dBm limit, in the 1 MHz bands immediately outside and adjacent to the top and bottom edges of the frequency block.
- 2) For the Out-of-Band measurements a 1 MHz RES BW was used to scan from 15 MHz to $10 \times f_0$ of the fundamental carrier for all frequency block. A display line was placed at -13dBm to show compliance for spurious, and harmonics.
- 3) 22.917(f): Mobile emissions in base frequency range. The mean power of any emissions appearing in the base station frequency range from cellular mobile transmitter operated must be attenuated to a level not to exceed -80dBm at the transmit antenna connector.

RESULT:

CDMA Modulation: Low / Mid / High, Band Edge, Out-Of-Band Emissions

Low Channel, Band edge:

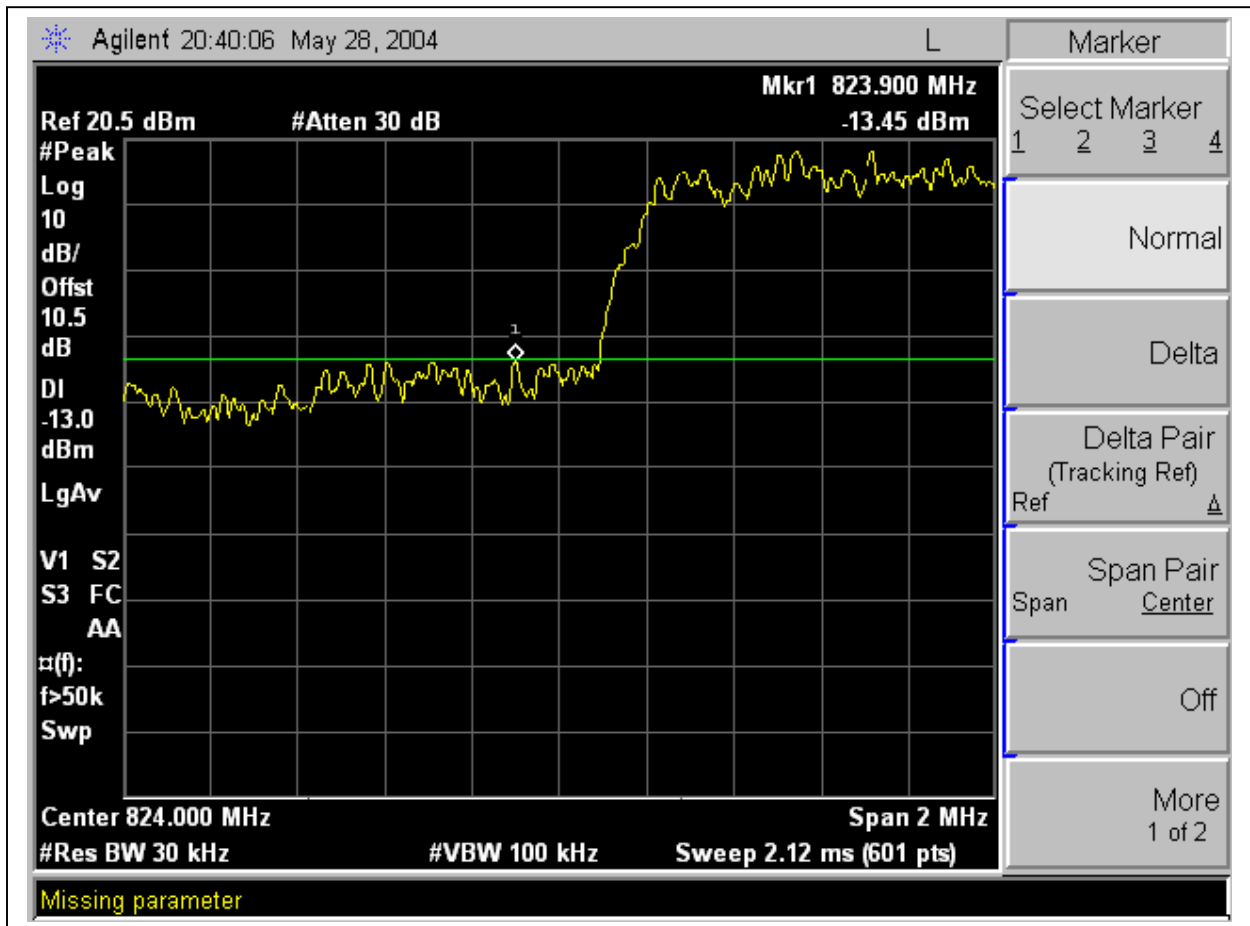

Low Channel, Out-Of-Band Emissions:

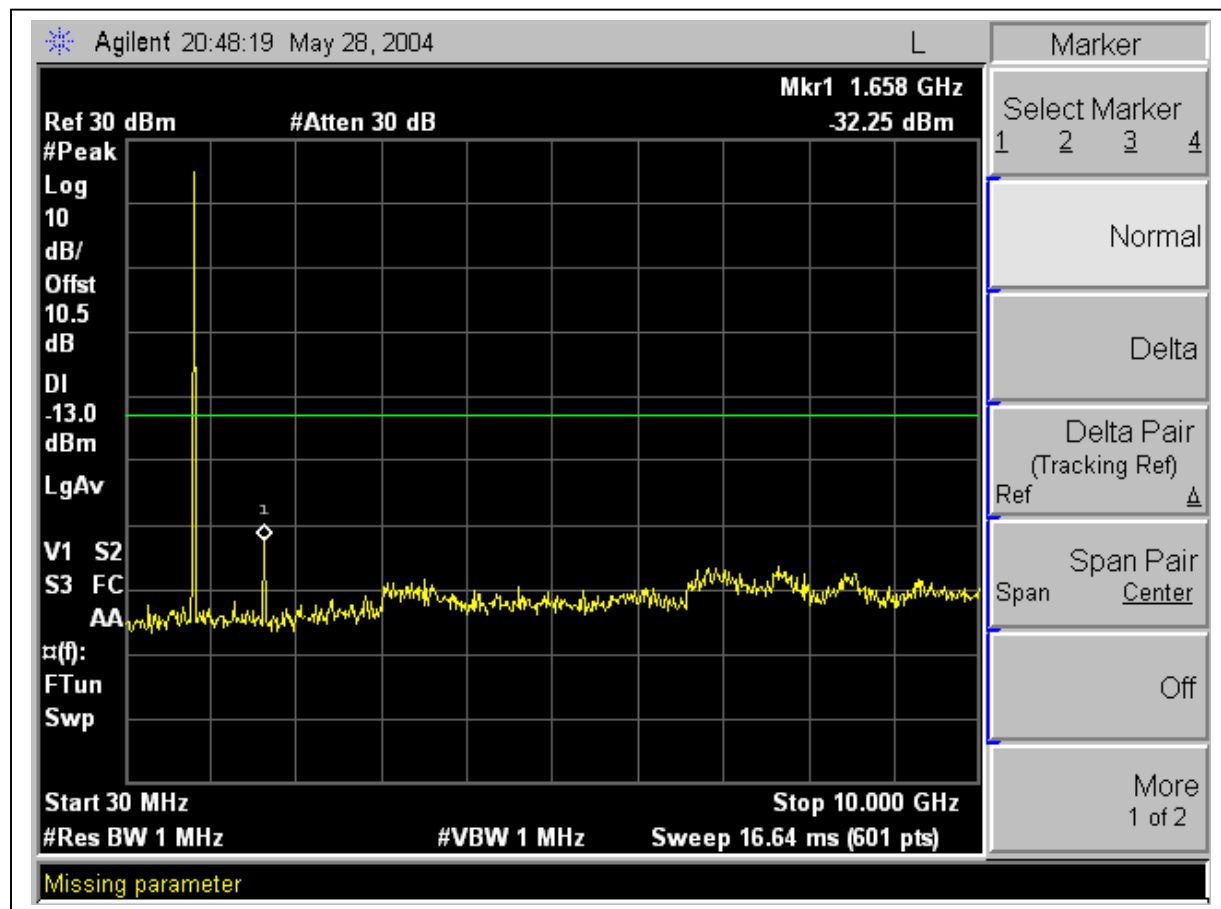

Mid Channel, Out-Of-Band Emissions:

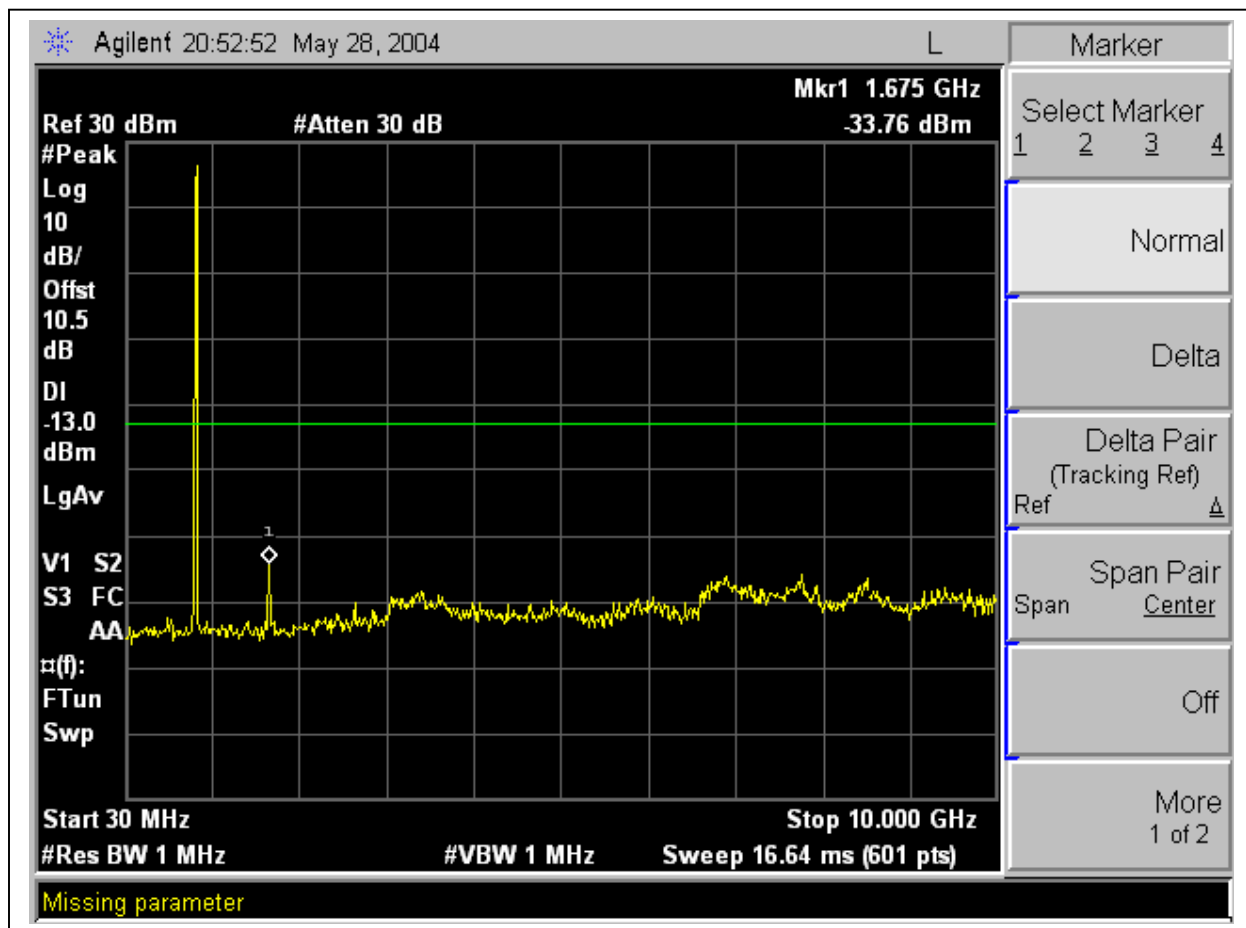

High Channel, Band edge:

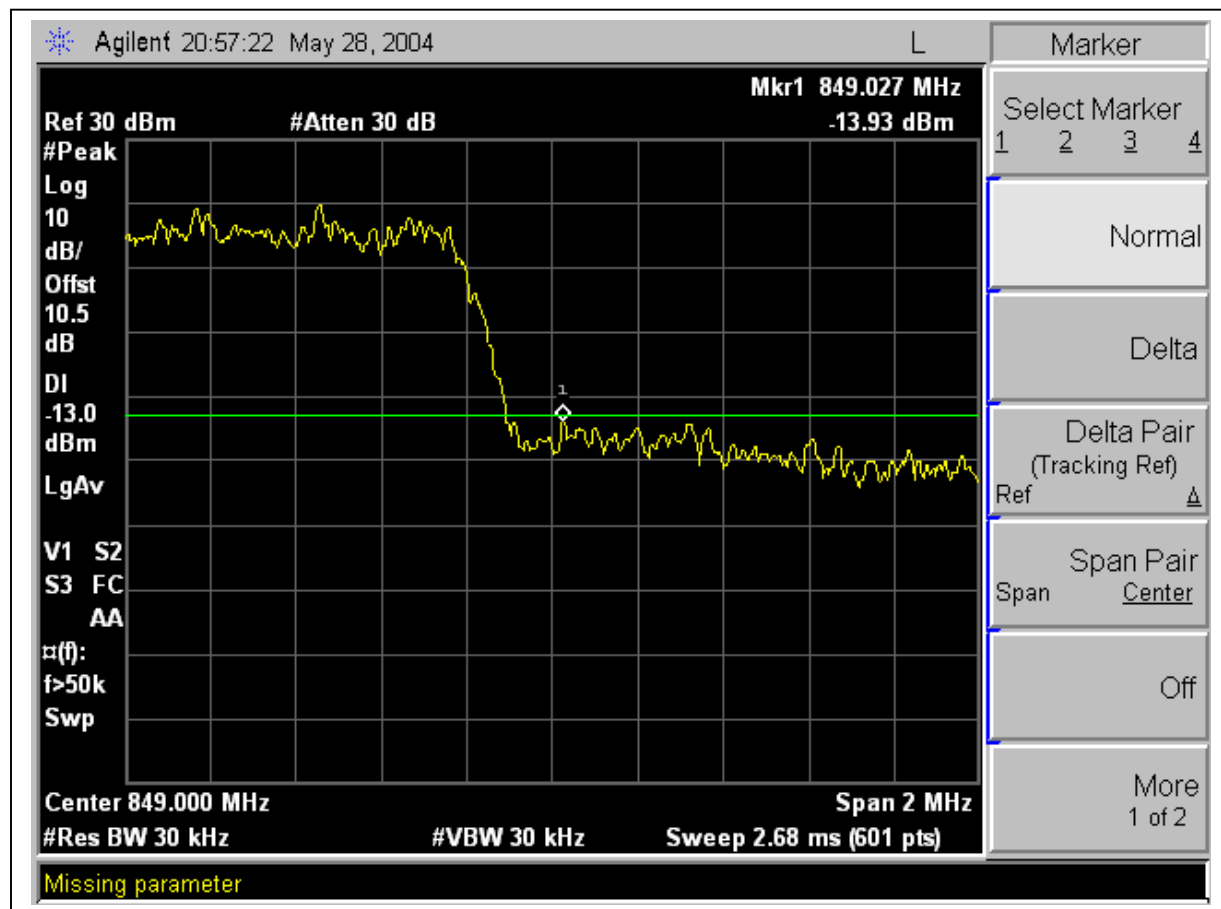

High Channel, Out-Of-Band Emissions:

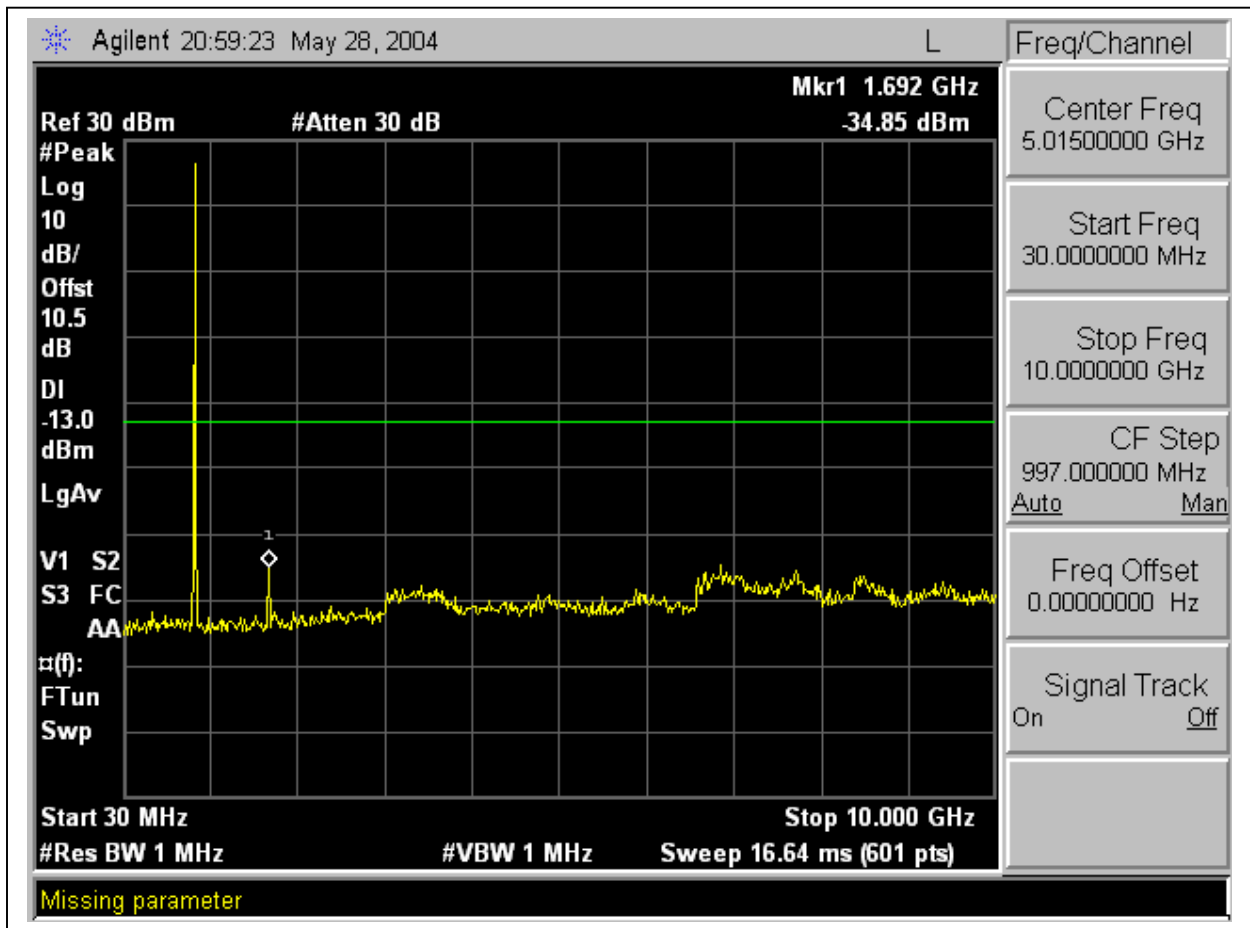

CDMA Mobile Emissions in Base Frequency Range:

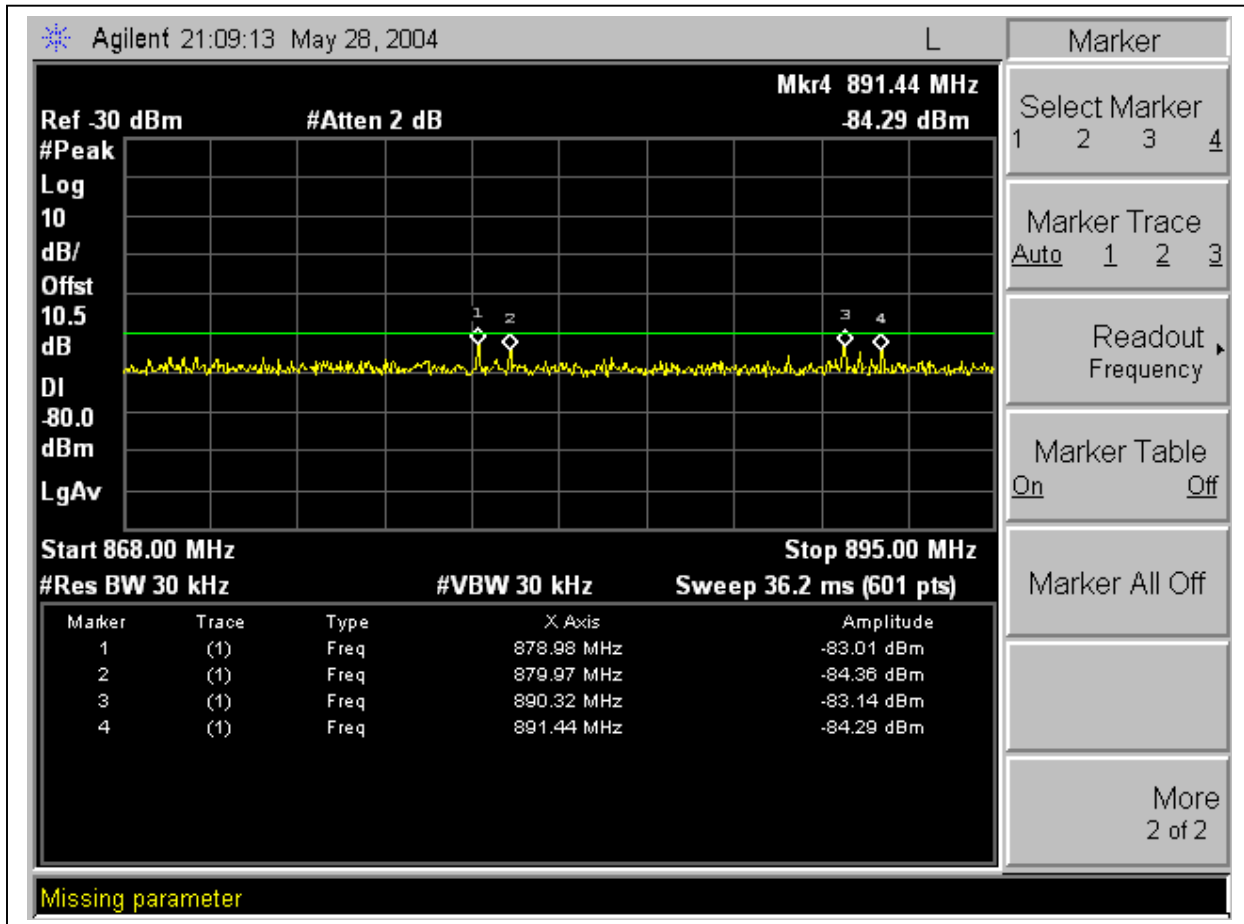

7.5. SECTION 2.1053: FIELD STRENGTH OF SPURIOUS RADIATION

INSTRUMENTS LIST

EQUIPMENT	MANUFACTURE	MODEL NO.	CAL. DUE DATE
Spectrum Analyzer	HP	8593EM	6/11/04
Amplifier	MITEQ	NSP2600-44	4/25/05
Signal Generator, 10 MHz ~ 20 GHz	HP	83732B	4/4/05
Bicon Antenna	Eaton	94455-1	3/6/05
LP Antenna	EMCO	3146	3/6/05
Adjustable Dipole	EMC Test Systems	3121C	5/26/05
Tx Horn Antenna	EMCO	3115	2/4/054
Rx Horn Antenna	EMCO	3115	2/4/05
HPF	MICROLAB	FH-1800H	N/A

Detector Function Setting of Test Receiver

Frequency Range (MHz)	Detector Function	Resolution Bandwidth	Video Bandwidth
Above 1000	<input checked="" type="checkbox"/> Peak <input type="checkbox"/> Average	<input checked="" type="checkbox"/> 1 MHz <input type="checkbox"/> 1 MHz	<input checked="" type="checkbox"/> 1 MHz <input type="checkbox"/> 10 Hz

TEST SETUP

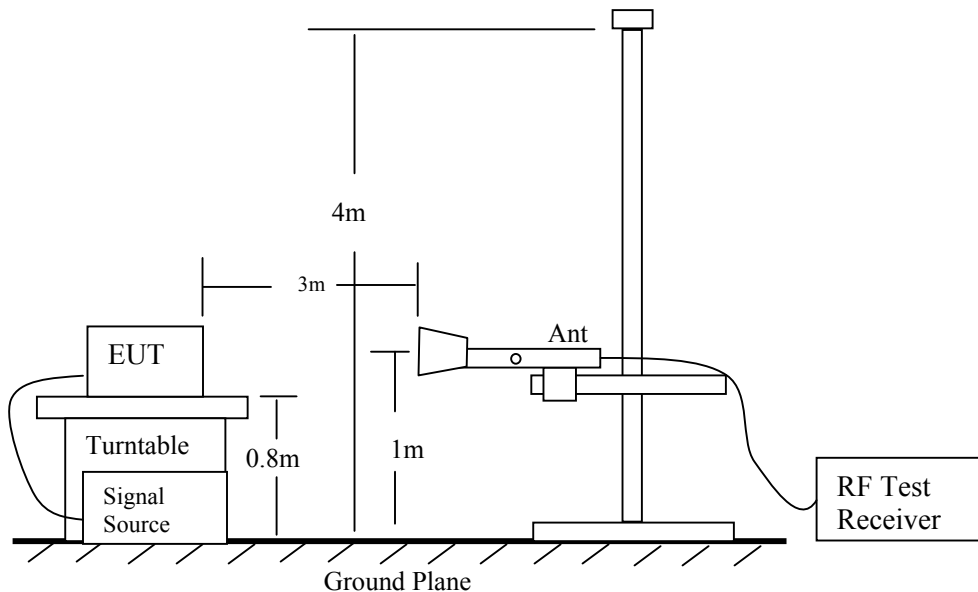

Radiated Emission Measurement

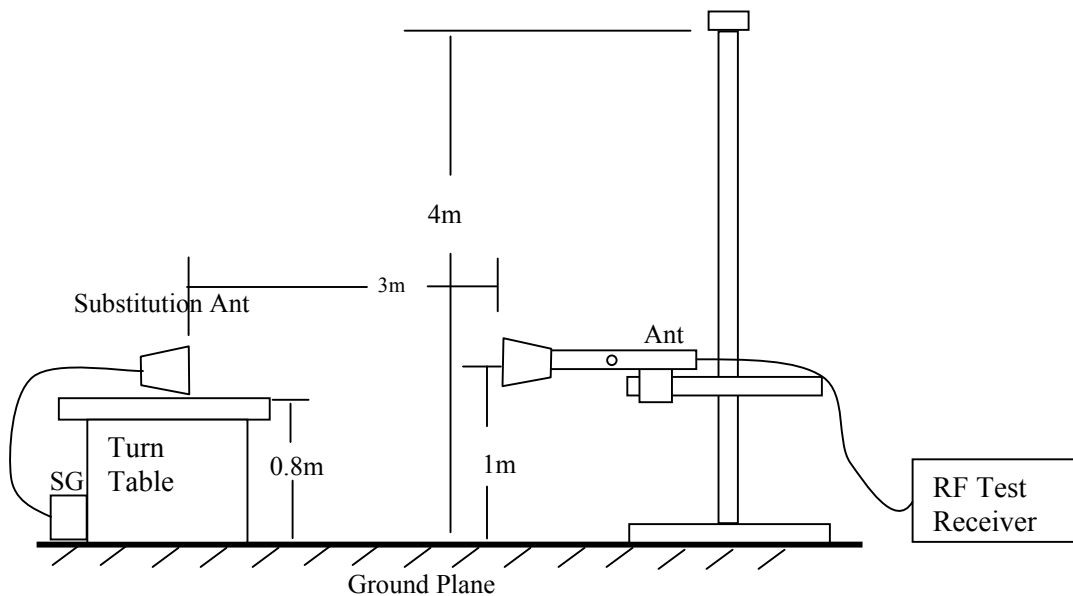

Radiated Emission – Substitution Method set-up

TEST PROCEDURE

- 1). On a test site, the EUT shall be placed on a turntable, and in the position closest to the normal use as declared by the user.
- 2). The test antenna shall be oriented initially for vertical polarization located 1m from the EUT to correspond to the frequency of the transmitter.
- 3). The output of the test antenna shall be connected to the measuring receiver and either a peak or average detector was used for the measurement as indicated on the report. The detector selection is based on how close the emission level was approaching the limit.
- 4). The transmitter shall be switched on; if possible, without the modulation and the measurement receiver shall be tuned to the frequency of the transmitter under test.
- 5). The test antenna shall be raised and lowered through the specified range of height until a maximum signal level is detected by the measuring receiver.
- 6). The transmitter shall then be rotated through 360° in the horizontal plane, until the maximum signal level is detected by the measuring receiver.
- 7). The test antenna shall be raised and lowered again through the specified range of height until a maximum signal level is detected by the measuring receiver.
- 8). The maximum signal level detected by the measuring receiver shall be noted.
- 9). The transmitter shall be replaced by a substitution antenna.
- 10). The substitution antenna shall be oriented for vertical polarization.
- 11). The substitution antenna shall be connected to a calibrated signal generator.
- 12). If necessary, the input attenuator setting of the measuring receiver shall be adjusted in order to increase the sensitivity of the measuring receiver.

- 13). The test antenna shall be raised and lowered through the specified range of the height to ensure that the maximum signal is received.
- 14). The input signal to the substitution antenna shall be adjusted to the level that produces a level detected by the measuring receiver, that is equal to the level noted while the transmitter radiated power was measured, corrected for the change of input attenuation setting of the measuring receiver.
- 15). The input level to the substitution antenna shall be recorded as power level in dBm, corrected for any change of input attenuator setting of the measuring receiver.
- 16). The measurement shall be repeated with the test antenna and the substitution antenna oriented for horizontal polarization.
- 17). The measure of the effective radiated power is the larger of the two levels recorded, at the input to the substitution antenna, corrected for the gain of the substitution antenna if necessary.

RESULT

No non-compliance noted, as shown below

CDMA: Low, Mid, & High Channels:

05/28/04 **High Frequency Substitution Measurement**
Compliance Certification Services, Morgan Hill 5m Chamber Site

Test Engr: Chin Pang
 Project #: 04I2757-1
 Company: LG ELECTRONIC
 EUT Descrip.: Single Band, Single Mode 800MHz CDMA Cellular Phone
 EUT M/N: LG-PD820
 Test Target: FCC PART 22
 Mode Oper: TX WORST CASE EUT AT Y POSITION

Test Equipment:

EMCO Horn 1-18GHz
 T73; S/N: 6717 @3m

Horn > 18GHz

Limit
 FCC 22

High Pass Filter

Hi Frequency Cables
 (2 ft) (2~3 ft) (4~6 ft) (12 ft)

Pre-amplifier 1-26GHz
 T87 Miteq 924342

Pre-amplifier 26-40GHz

f GHz	SA reading (dBuV/m)	Ant. Pol. (H/V)	SG reading (dBm)	CL (dB)	Gain (dBi)	Gain (dBd)	ERP (dBm)	Limit (dBm)	Margin (dB)	Notes
Low ch , 824.82MHz										
1.650	71.3	V	-39.6	2.1	7.5	5.4	-36.3	-13.0	-23.3	Y Position
2.474	49.6	V	-57.8	2.6	8.6	6.4	-54.0	-13.0	-41.0	
1.650	63.5	H	-46.7	2.1	7.5	5.4	-43.4	-13.0	-30.4	
2.474	47.3	H	-59.9	2.6	8.6	6.4	-56.1	-13.0	-43.1	
Mid ch , 836.49MHz										
1.673	68.2	V	-42.6	2.1	7.6	5.4	-39.2	-13.0	-26.2	Y Position
2.509	48.0	V	-59.3	2.6	8.6	6.4	-55.4	-13.0	-42.4	
1.673	63.0	H	-47.0	2.1	7.6	5.4	-43.7	-13.0	-30.7	
2.509	45.0	H	-62.1	2.6	8.6	6.4	-58.2	-13.0	-45.2	
High ch, 848.19MHz										
1.696	67.7	V	-42.9	2.1	7.6	5.5	-39.6	-13.0	-26.6	Y Position
2.545	47.2	V	-60.0	2.6	8.6	6.5	-56.1	-13.0	-43.1	
1.696	63.3	H	-46.6	2.1	7.6	5.5	-43.3	-13.0	-30.3	
2.545	48.9	H	-58.1	2.6	8.6	6.5	-54.2	-13.0	-41.2	
Note: No other emissions were found up to 10GHz.										

7.6. SECTION 2.1055: FREQUENCY STABILITY

INSTRUMENTS LIST

EQUIPMENT	MANUFACTURE	MODEL NO.	CAL. DUE DATE
DC Power	Kenwood	PA36-3A	CNR
EMI Test Receiver	R & S	ESIB 40	11/21/04
Environmental Chamber	Thermotron	SE 600-10-10	4/26/05

Detector Function Setting of Test Receiver

Frequency Range (MHz)	Detector Function	Resolution Bandwidth	Video Bandwidth
Mid Channel	Peak	300 Hz	300 Hz

TEST SETUP

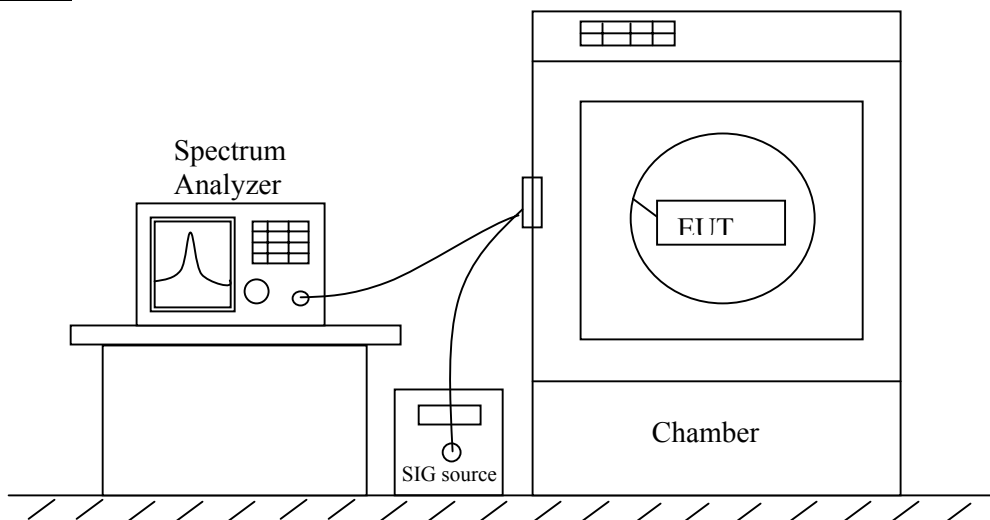

Fig. 3: Frequency Stability Setup

TEST PROCEDURE

- **Frequency stability versus environmental temperature**

- 1). Setup the configuration per figure 6 for frequencies measurement inside the environmental chamber. Set the temperature of the chamber to 25°C. Set SA Resolution Bandwidth low enough to obtain the desired frequency resolution and measure the EUT 25°C operating frequency as reference frequency.
- 2). Turn EUT off and set Chamber temperature to -30°C.
- 3). Allow sufficient time (approximately 20 to 30 minus after chamber reach the assigned temperature) for EUT to stabilize. Turn on EUT and measure the EUT operating frequency. Turn off EUT after the measurement.
- 4). Repeat step 3 with a 10°C increased per stage until the highest temperature of +50°C reached, record all measured frequencies on each temperature step.

- **Frequency stability versus AC input voltage**

- 1). Setup the configuration per figure 6 and set chamber temperature to 25°C. Use a variable AC power supply to power the EUT and set AC output voltage to EUT nominal input AC voltage. Set SA Resolution Bandwidth low enough to obtain the desired frequency resolution and measure the EUT 25°C operating frequency as reference frequency.
- 2). Slowly reduce the EUT input voltage to specified extreme voltage variation ($\pm 15\%$) and record the maximum frequency change.

RESULT

No non-compliance noted, as shown below because the EUT uses the same OSC in both receiver and transmitter LO circuit. As a result, the frequency does not shift in Frequency Stability Test.

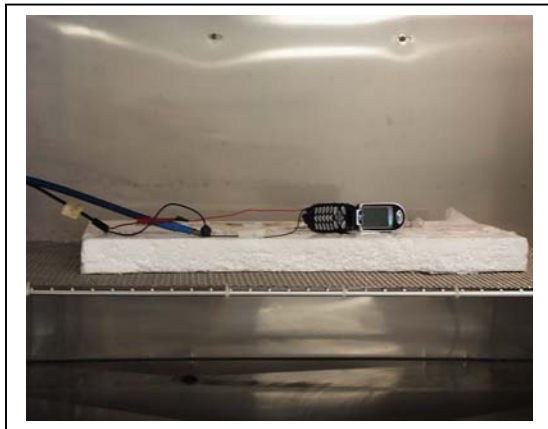

Reference Frequency: CDMA Mid Channel 835.762812MHz @ 25°C				
Limit: to stay ± 2.5 ppm = 2089.407 Hz				
Power Supply (Vdc)	Environment Temperature (°C)	Frequency Deviation Measured with Time Elapse		
		(MHz)	Delta (ppm)	Limit (ppm)
3.70	50	835.76379	-1.174	± 2.5
3.70	40	835.76380	-1.183	± 2.5
3.70	30	835.76351	-0.838	± 2.5
3.70	25	835.76281	0	± 2.5
3.70	20	835.76319	-0.456	± 2.5
3.70	10	835.76349	-0.815	± 2.5
3.70	0	835.76379	-1.174	± 2.5
3.70	-10	835.76376	-1.133	± 2.5
3.70	-20	835.76399	-1.406	± 2.5
3.70	-30	835.76390	-1.304	± 2.5
Reference Frequency: CDMA Mid Channel 835.762812MHz @ 25°C				
Limit: to stay ± 2.5 ppm = 2089.407 Hz				
Power Supply (Vdc)	Environment Temperature (°C)	Frequency Deviation Measured with Time Elapse		
		(MHz)	Delta (ppm)	Limit (ppm)
3.70	25	835.76281	0	± 2.5
2.85 - 3.00 (end point)	25	835.76188	1.116	± 2.5
3.15	25	835.76378	-1.157	± 2.5
4.26	25	835.76169	1.339	± 2.5

8. APENDIX

8.1. EXTERNAL & INTERNAL PHOTOS

Please refer to attached sheets.

8.2. SCHEMATICS

Please refer to attached sheets.

8.3. BLOCK DIAGRAM

Please refer to attached sheets.

8.4. USER MANUAL

Please refer to attached sheets.

END OF REPORT