

## 7.4. Test Results

### 7.4.1. Radiated Emissions

#### 9 kHz ~ 25 GHz Data (Modulation : GFSK)

##### ▪ Lowest Channel

Frequency (MHz)	AN T Pol	The worst case EUT Position (Axis)	Detector Mode	Reading (dBuV)	T.F (dB/m)	D.C.F (dB)	Distance Factor (dB)	Result (dBuV/m)	Limit (dBuV/m)	Margin (dB)
2322.24	H	Y	PK	47.94	3.54	N/A	N/A	51.48	74.00	22.52
2322.04	H	Y	AV	39.56	3.54	-24.79	N/A	18.31	54.00	35.69
2390.00	H	Y	PK	44.71	3.54	N/A	N/A	48.25	74.00	25.75
2390.00	H	Y	AV	34.62	3.54	-24.79	N/A	13.37	54.00	40.63
4804.02	H	Y	PK	44.85	9.50	N/A	N/A	54.35	74.00	19.65
4804.01	H	Y	AV	32.59	9.50	-24.79	N/A	17.30	54.00	36.70

##### ▪ Middle Channel

Frequency (MHz)	AN T Pol	The worst case EUT Position (Axis)	Detector Mode	Reading (dBuV)	T.F (dB/m)	D.C.F (dB)	Distance Factor (dB)	Result (dBuV/m)	Limit (dBuV/m)	Margin (dB)
4881.77	H	Y	PK	45.38	9.73	N/A	N/A	55.11	74.00	18.89
4882.02	H	Y	AV	32.95	9.73	-24.79	N/A	17.89	54.00	36.11

##### ▪ Highest Channel

Frequency (MHz)	AN T Pol	The worst case EUT Position (Axis)	Detector Mode	Reading (dBuV)	T.F (dB/m)	D.C.F (dB)	Distance Factor (dB)	Result (dBuV/m)	Limit (dBuV/m)	Margin (dB)
2484.68	H	Y	PK	48.55	3.70	N/A	N/A	52.25	74.00	21.75
2484.70	H	Y	AV	35.11	3.70	-24.79	N/A	14.02	54.00	39.98
4959.87	H	Y	PK	43.73	9.93	N/A	N/A	53.66	74.00	20.34
4960.11	H	Y	AV	32.61	9.93	-24.79	N/A	17.75	54.00	36.25

##### ▪ Note.

1. No other spurious and harmonic emissions were found greater than listed emissions on above table.

2. Information of Distance Factor

For finding emissions, the test distance might be reduced from 3m to 1m. In this case, the distance factor(-9.54dB) is applied to the result.

- Calculation of distance factor =  $20 \log(\text{applied distance} / \text{required distance}) = 20 \log(1 \text{ m} / 3 \text{ m}) = -9.54 \text{ dB}$

When distance factor is "N/A", the distance is 3 m and distance factor is not applied.

3. D.C.F Calculation. (D.C.F = Duty Cycle Correction Factor)

- Time to cycle through all channels =  $\Delta t = T [\text{ms}] \times 20$  minimum hopping channels, where T = pulse width = **2.88 ms**

-  $100 \text{ ms} / \Delta t [\text{ms}] = H \rightarrow$  Round up to next highest integer, to account for worst case,  $H' = 100 / (2.88 \times 20) = 1.736 \approx 2$

- The Worst Case Dwell Time =  $T [\text{ms}] \times H' = 2.88 \text{ ms} \times 2 = 5.76 \text{ ms}$

- D.C.F =  $20 \log(\text{The Worst Case Dwell Time} / 100 \text{ ms}) \text{ dB} = 20 \log(5.76 / 100) = -24.79 \text{ dB}$

4. Sample Calculation.

Margin = Limit – Result / Result = Reading + T.F + D.C.F / T.F = AF + CL – AG

Where, T.F = Total Factor, AF = Antenna Factor, CL = Cable Loss, AG = Amplifier Gain.

### 9 kHz ~ 25 GHz Data (Modulation : $\pi/4$ DQPSK)

#### ▪ Lowest Channel

Frequency (MHz)	ANT Pol	The worst case EUT Position (Axis)	Detector Mode	Reading (dBuV)	T.F (dB/m)	D.C.F (dB)	Distance Factor (dB)	Result (dBuV/m)	Limit (dBuV/m)	Margin (dB)
2322.36	H	Y	PK	47.68	3.54	N/A	N/A	51.22	74.00	22.78
2322.12	H	Y	AV	38.00	3.54	-24.79	N/A	16.75	54.00	37.25
2390.00	H	Y	PK	44.46	3.54	N/A	N/A	48.00	74.00	26.00
2390.00	H	Y	AV	34.52	3.54	-24.79	N/A	13.27	54.00	40.73
4803.27	H	Y	PK	45.29	9.50	N/A	N/A	54.79	74.00	19.21
4803.74	H	Y	AV	32.09	9.50	-24.79	N/A	16.80	54.00	37.20

#### ▪ Middle Channel

Frequency (MHz)	ANT Pol	The worst case EUT Position (Axis)	Detector Mode	Reading (dBuV)	T.F (dB/m)	D.C.F (dB)	Distance Factor (dB)	Result (dBuV/m)	Limit (dBuV/m)	Margin (dB)
4881.77	H	Y	PK	44.95	9.73	N/A	N/A	54.68	74.00	19.32
4882.40	H	Y	AV	32.14	9.73	-24.79	N/A	17.08	54.00	36.92

#### ▪ Highest Channel

Frequency (MHz)	ANT Pol	The worst case EUT Position (Axis)	Detector Mode	Reading (dBuV)	T.F (dB/m)	D.C.F (dB)	Distance Factor (dB)	Result (dBuV/m)	Limit (dBuV/m)	Margin (dB)
2484.02	H	Y	PK	46.46	3.70	N/A	N/A	50.16	74.00	23.84
2483.50	H	Y	AV	35.32	3.70	-24.79	N/A	14.23	54.00	39.77
4959.31	H	Y	PK	43.89	9.93	N/A	N/A	53.82	74.00	20.18
4959.80	H	Y	AV	31.95	9.93	-24.79	N/A	17.09	54.00	36.91

#### ▪ Note.

1. No other spurious and harmonic emissions were found greater than listed emissions on above table.
2. Information of Distance Factor

For finding emissions, the test distance might be reduced from 3m to 1m. In this case, the distance factor(-9.54dB) is applied to the result.

- Calculation of distance factor =  $20 \log(\text{applied distance} / \text{required distance}) = 20 \log(1 \text{ m} / 3 \text{ m}) = -9.54 \text{ dB}$

When distance factor is "N/A", the distance is 3 m and distance factor is not applied.

3. D.C.F Calculation. (D.C.F = Duty Cycle Correction Factor)

- Time to cycle through all channels =  $\Delta t = T [\text{ms}] \times 20$  minimum hopping channels, where T = pulse width = **2.88 ms**

-  $100 \text{ ms} / \Delta t [\text{ms}] = H \rightarrow$  Round up to next highest integer, to account for worst case,  $H' = 100 / (2.88 \times 20) = 1.736 \approx 2$

- The Worst Case Dwell Time =  $T [\text{ms}] \times H' = 2.88 \text{ ms} \times 2 = 5.76 \text{ ms}$

- D.C.F =  $20 \text{ Log}(\text{The Worst Case Dwell Time} / 100 \text{ ms}) \text{ dB} = 20 \log(5.76 / 100) = -24.79 \text{ dB}$

4. Sample Calculation.

Margin = Limit – Result / Result = Reading + T.F + D.C.F / T.F = AF + CL – AG

Where, T.F = Total Factor, AF = Antenna Factor, CL = Cable Loss, AG = Amplifier Gain.

### 9 kHz ~ 25 GHz Data (Modulation : 8DPSK)

#### ▪ Lowest Channel

Frequency (MHz)	ANT Pol	The worst case EUT Position (Axis)	Detector Mode	Reading (dBuV)	T.F (dB/m)	D.C.F (dB)	Distance Factor (dB)	Result (dBuV/m)	Limit (dBuV/m)	Margin (dB)
2322.24	H	Y	PK	47.51	3.54	N/A	N/A	51.05	74.00	22.95
2322.06	H	Y	AV	37.62	3.54	-24.79	N/A	16.37	54.00	37.63
2390.00	H	Y	PK	42.71	3.54	N/A	N/A	46.25	74.00	27.75
2390.00	H	Y	AV	34.71	3.54	-24.79	N/A	13.46	54.00	40.54
4803.50	H	Y	PK	44.14	9.50	N/A	N/A	53.64	74.00	20.36
4804.28	H	Y	AV	31.99	9.50	-24.79	N/A	16.70	54.00	37.30

#### ▪ Middle Channel

Frequency (MHz)	ANT Pol	The worst case EUT Position (Axis)	Detector Mode	Reading (dBuV)	T.F (dB/m)	D.C.F (dB)	Distance Factor (dB)	Result (dBuV/m)	Limit (dBuV/m)	Margin (dB)
4882.75	H	Y	PK	45.39	9.73	N/A	N/A	55.12	74.00	18.88
4882.81	H	Y	AV	32.20	9.73	-24.79	N/A	17.14	54.00	36.86

#### ▪ Highest Channel

Frequency (MHz)	ANT Pol	The worst case EUT Position (Axis)	Detector Mode	Reading (dBuV)	T.F (dB/m)	D.C.F (dB)	Distance Factor (dB)	Result (dBuV/m)	Limit (dBuV/m)	Margin (dB)
2484.36	H	Y	PK	48.27	3.70	N/A	N/A	51.97	74.00	22.03
2483.50	H	Y	AV	35.02	3.70	-24.79	N/A	13.93	54.00	40.07
4960.15	H	Y	PK	43.60	9.93	N/A	N/A	53.53	74.00	20.47
4959.93	H	Y	AV	32.01	9.93	-24.79	N/A	17.15	54.00	36.85

#### ▪ Note.

1. No other spurious and harmonic emissions were found greater than listed emissions on above table.
2. Information of Distance Factor

For finding emissions, the test distance might be reduced from 3m to 1m. In this case, the distance factor(-9.54dB) is applied to the result.

- Calculation of distance factor =  $20 \log(\text{applied distance} / \text{required distance}) = 20 \log(1 \text{ m} / 3 \text{ m}) = -9.54 \text{ dB}$

When distance factor is "N/A", the distance is 3 m and distance factor is not applied.

3. D.C.F Calculation. (D.C.F = Duty Cycle Correction Factor)

- Time to cycle through all channels =  $\Delta t = T [\text{ms}] \times 20$  minimum hopping channels, where T = pulse width = **2.88 ms**

-  $100 \text{ ms} / \Delta t [\text{ms}] = H \rightarrow$  Round up to next highest integer, to account for worst case,  $H' = 100 / (2.88 \times 20) = 1.736 \approx 2$

- The Worst Case Dwell Time =  $T [\text{ms}] \times H' = 2.88 \text{ ms} \times 2 = 5.76 \text{ ms}$

- D.C.F =  $20 \text{ Log}(\text{The Worst Case Dwell Time} / 100 \text{ ms}) \text{ dB} = 20 \text{ log}(5.76 / 100) = -24.79 \text{ dB}$

4. Sample Calculation.

Margin = Limit – Result / Result = Reading + T.F + D.C.F / T.F = AF + CL – AG

Where, T.F = Total Factor, AF = Antenna Factor, CL = Cable Loss, AG = Amplifier Gain.

### 7.4.2. Conducted Spurious Emissions

#### Low Band-edge

#### *Lowest Channel & Modulation : GFSK*

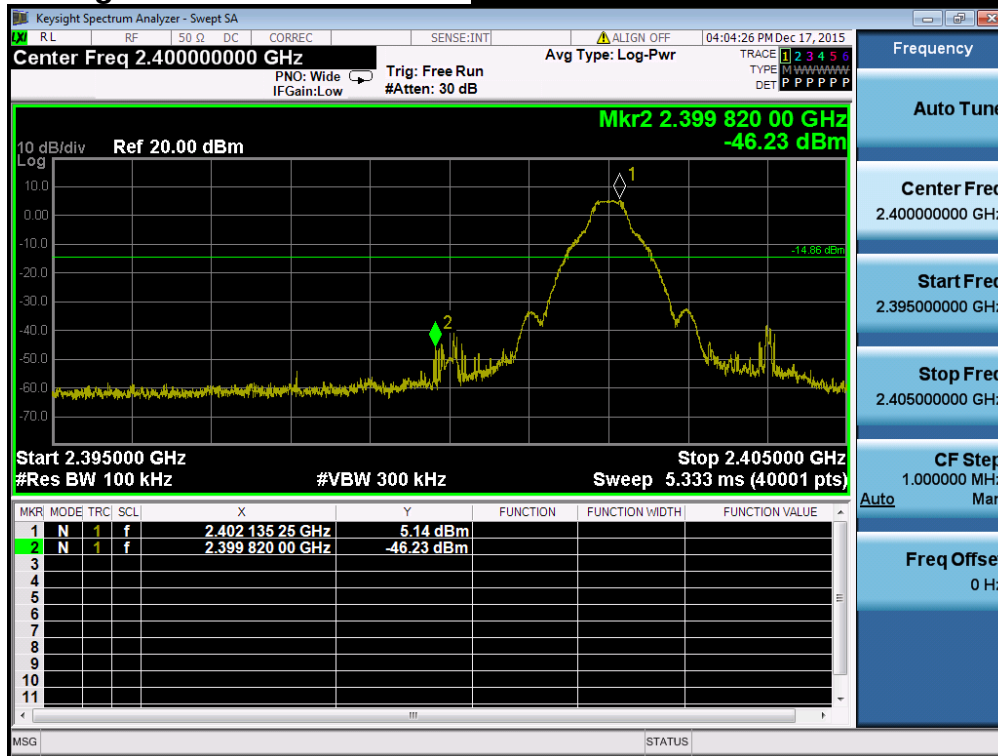

#### Low Band-edge

#### *Hopping mode & Modulation : GFSK*

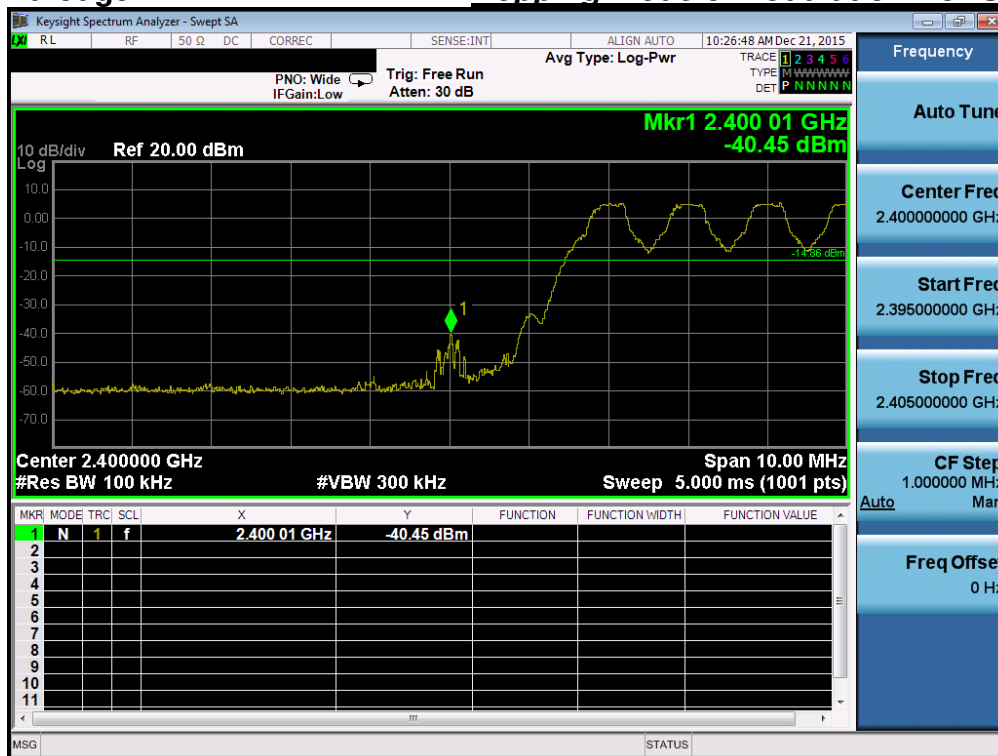

**Conducted Spurious Emissions** *Lowest Channel & Modulation : GFSK*

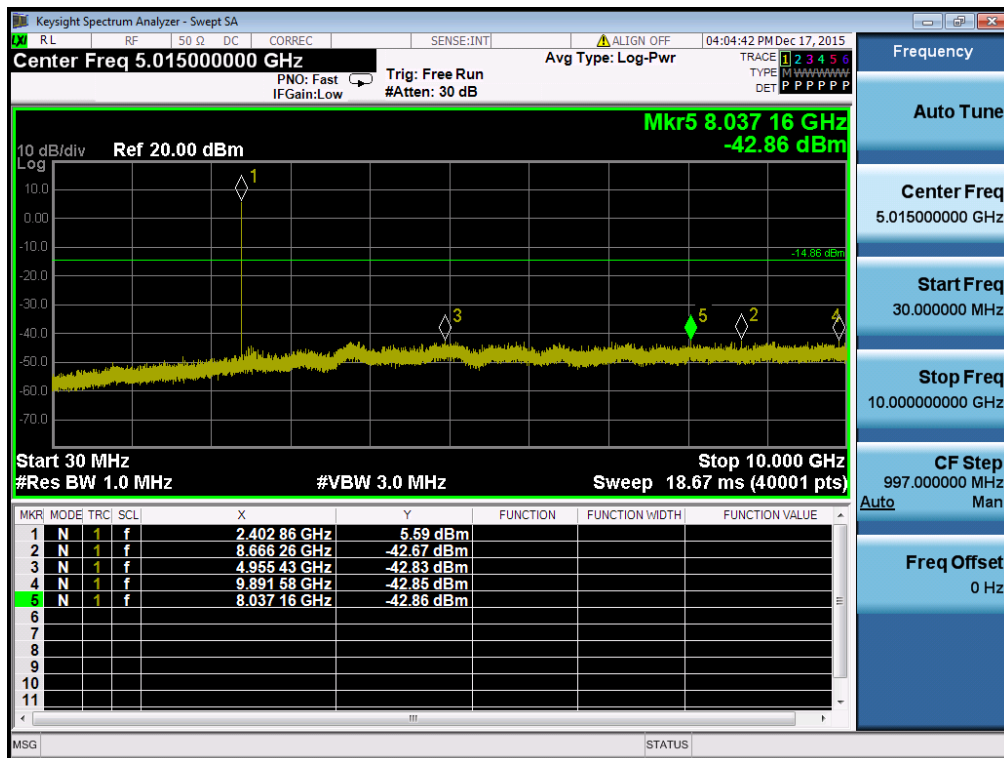
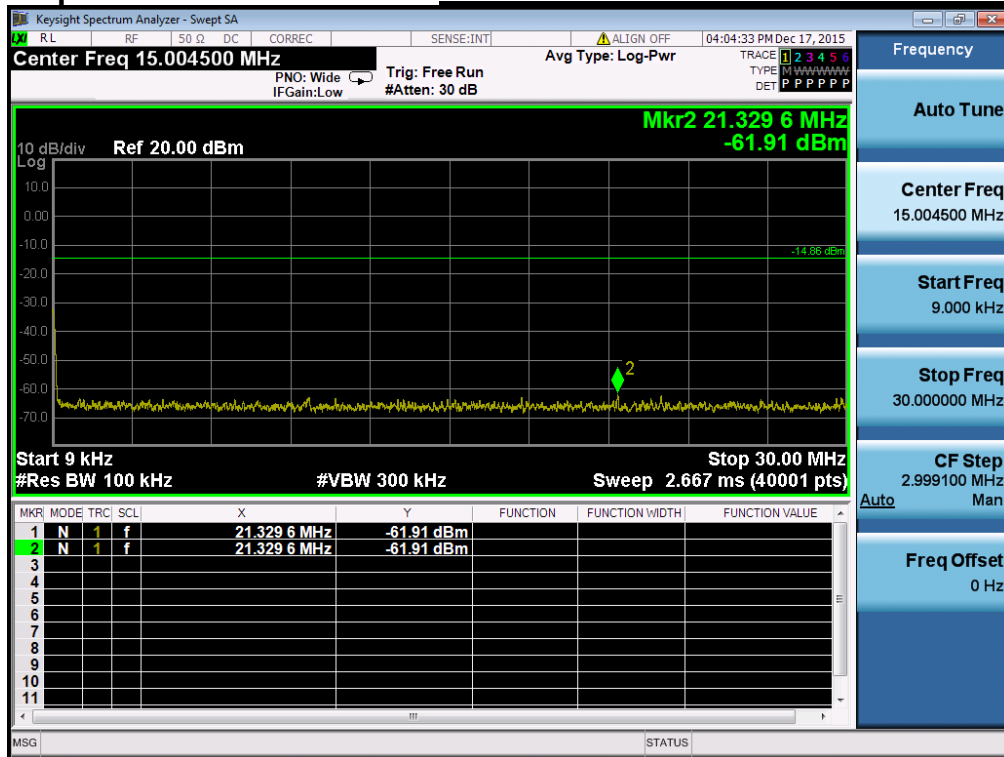

**Conducted Spurious Emissions** *Lowest Channel & Modulation : GFSK*

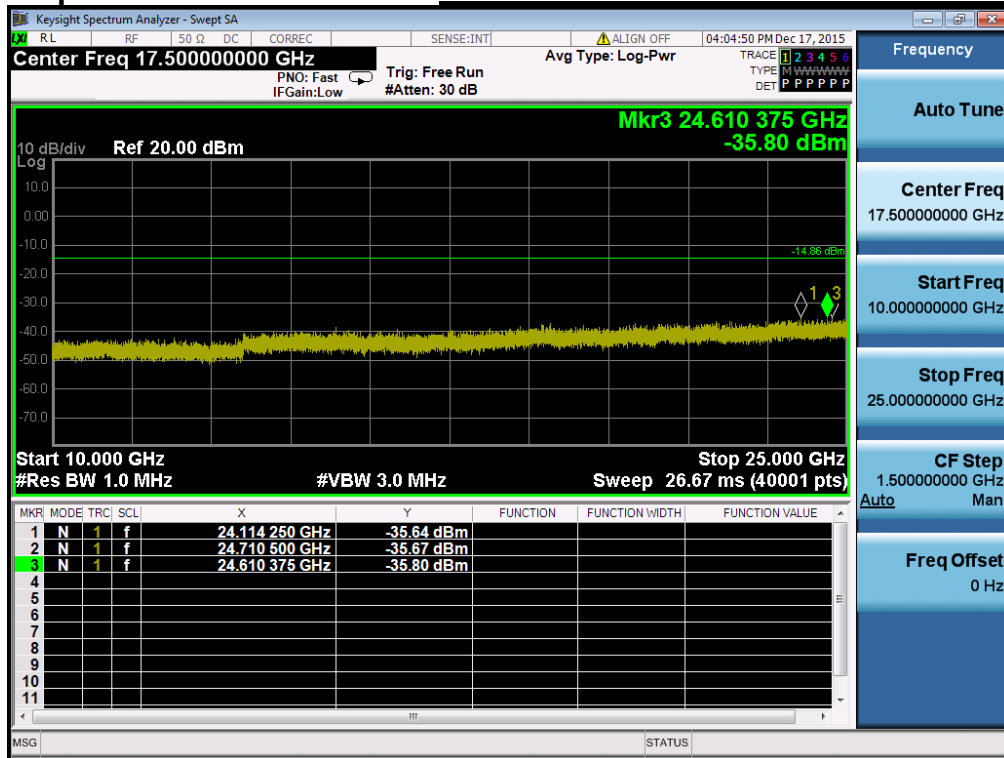

Reference for limit

Middle Channel & Modulation : GFSK

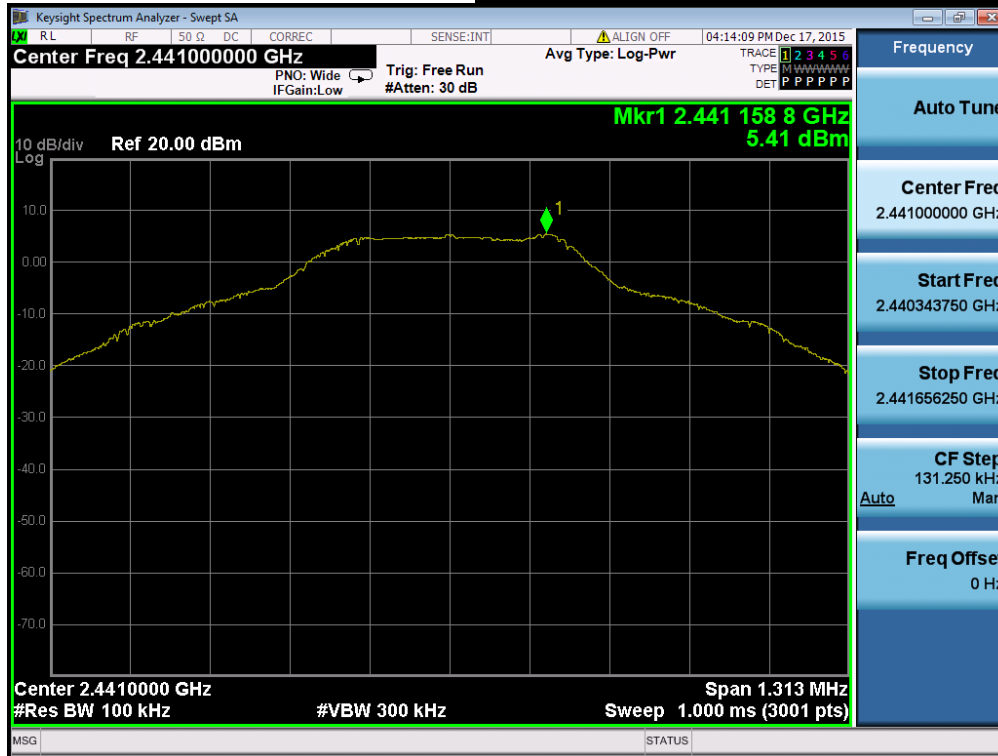

Conducted Spurious Emissions

Middle Channel & Modulation : GFSK

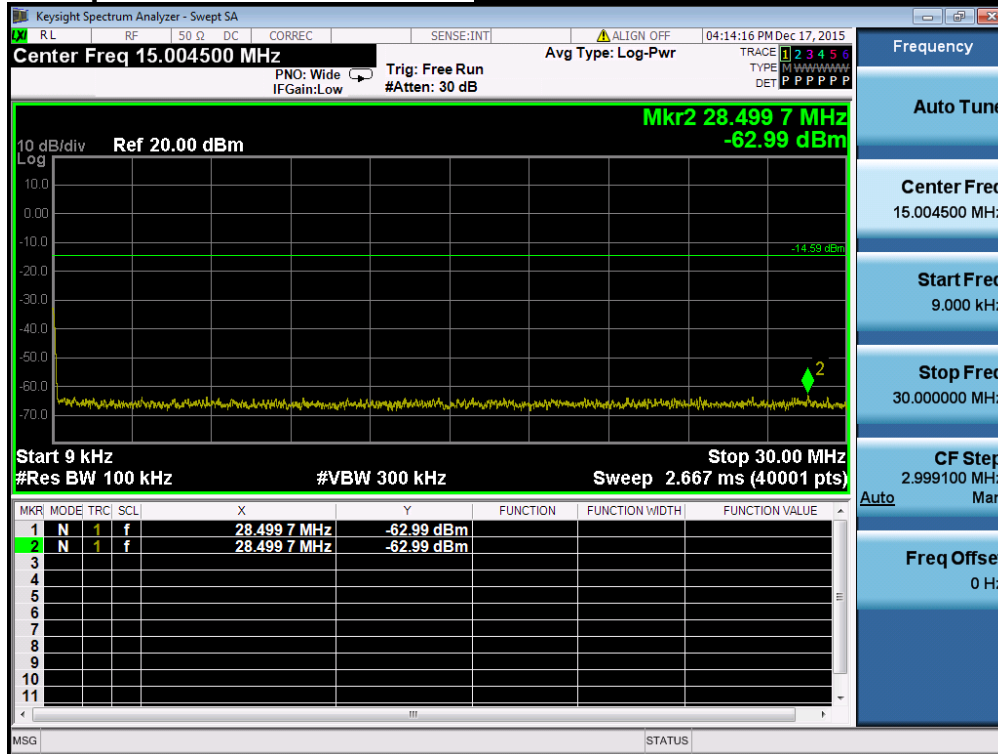

**Conducted Spurious Emissions** *Middle Channel & Modulation : GFSK*

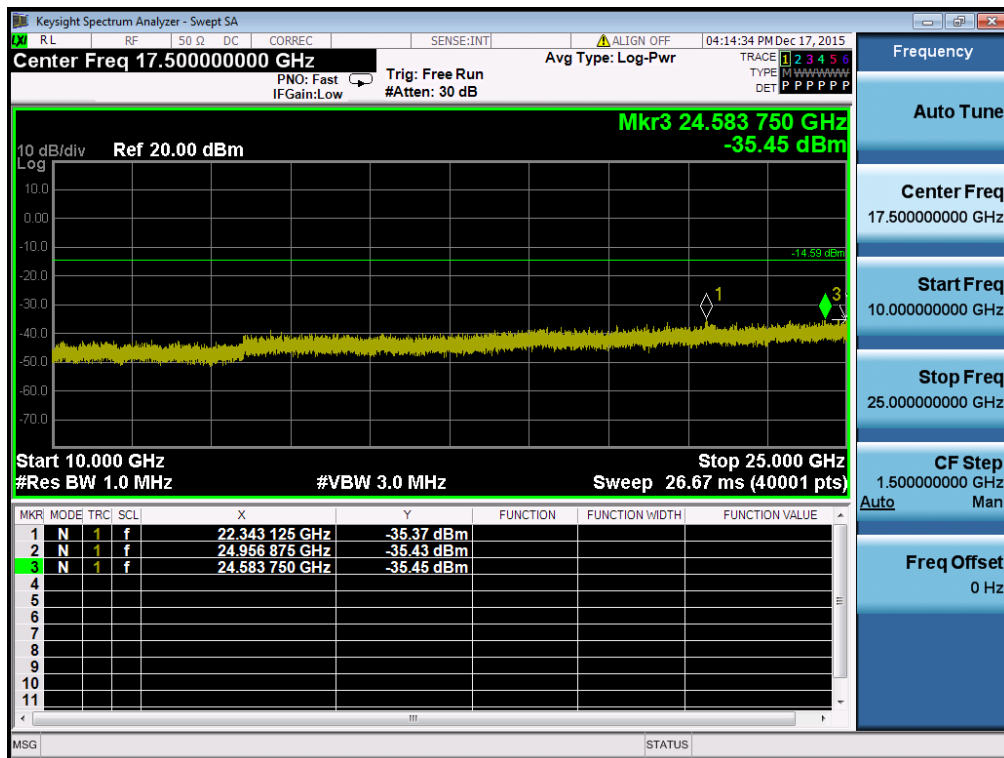
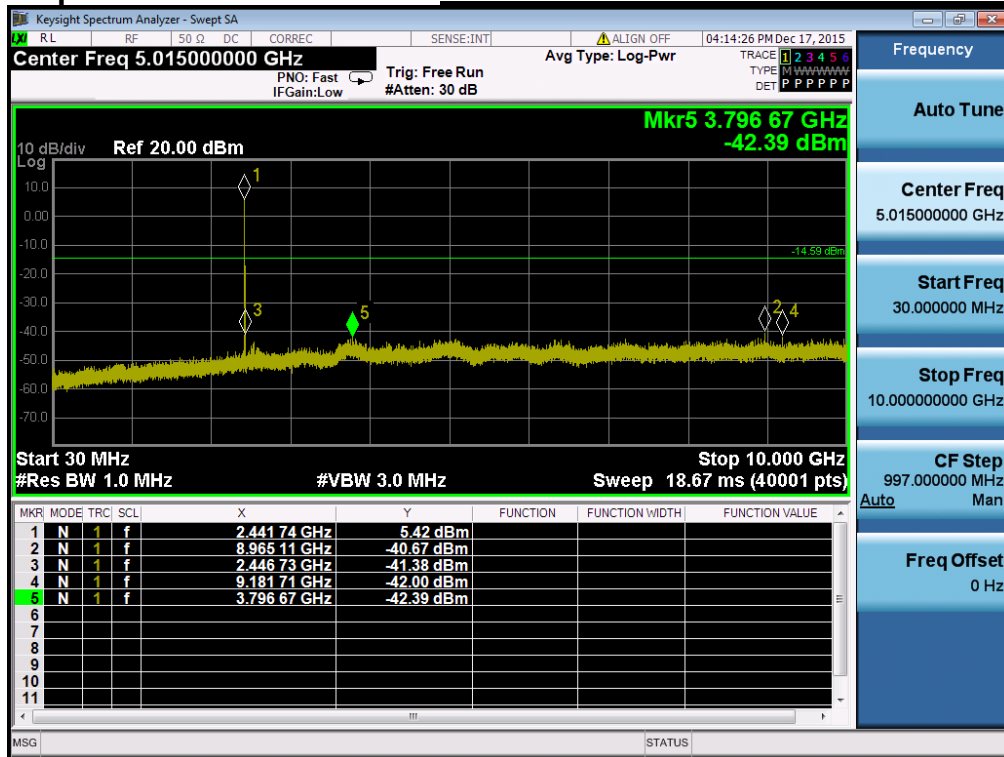

High Band-edge

Highest Channel & Modulation : GFSK

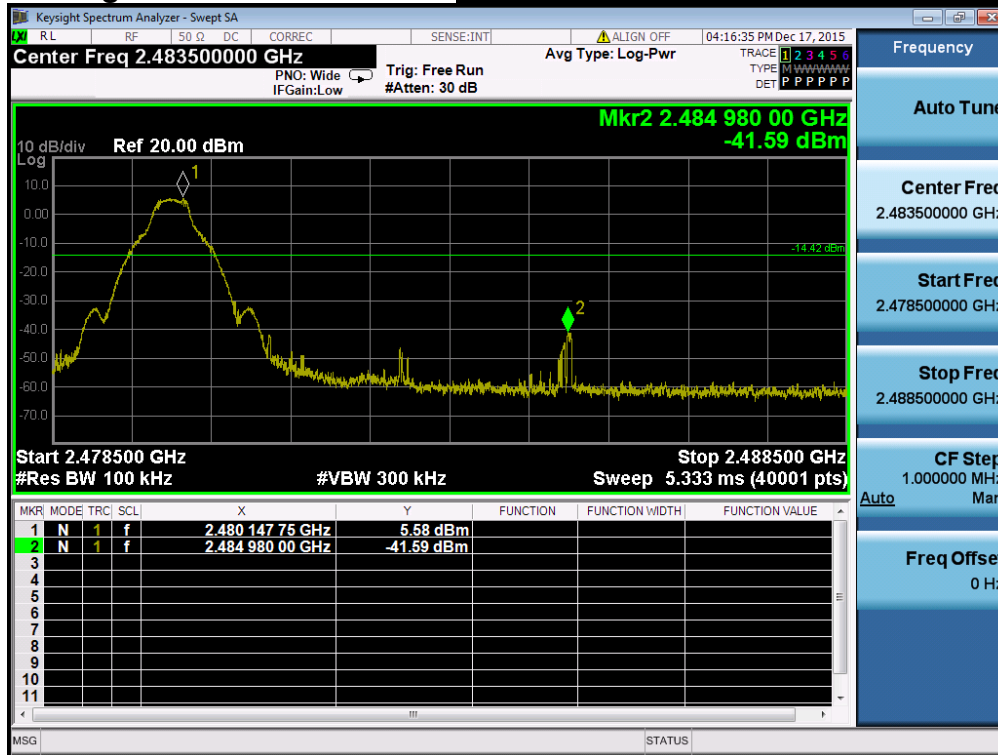

High Band-edge

Hopping mode & Modulation : GFSK

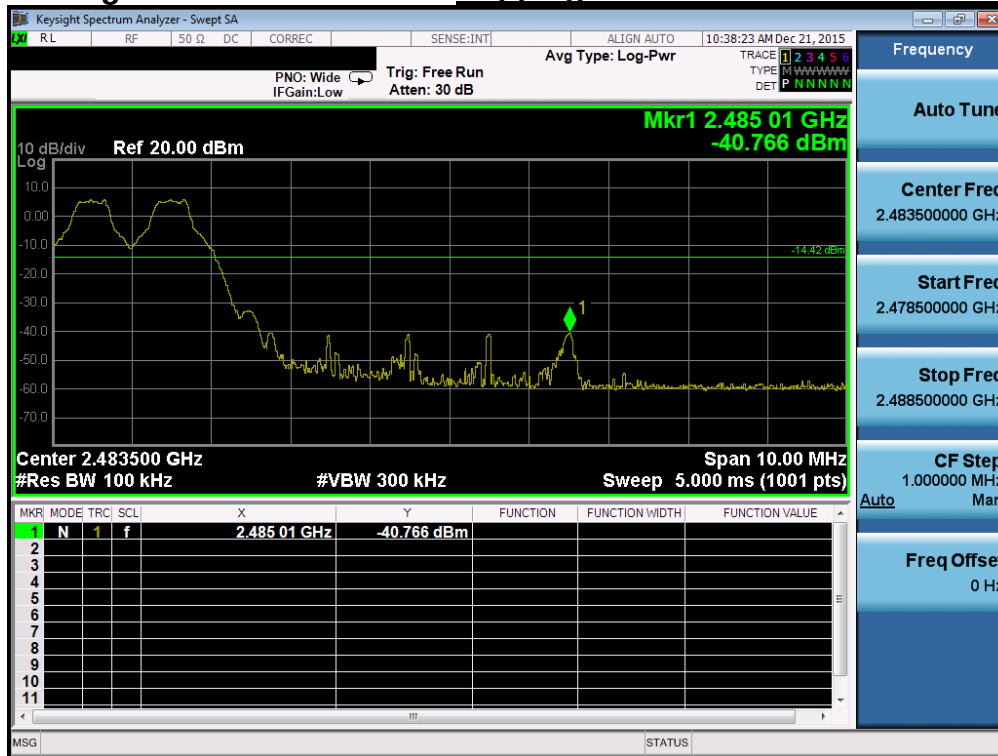

**Conducted Spurious Emissions**      *Highest Channel & Modulation : GFSK*

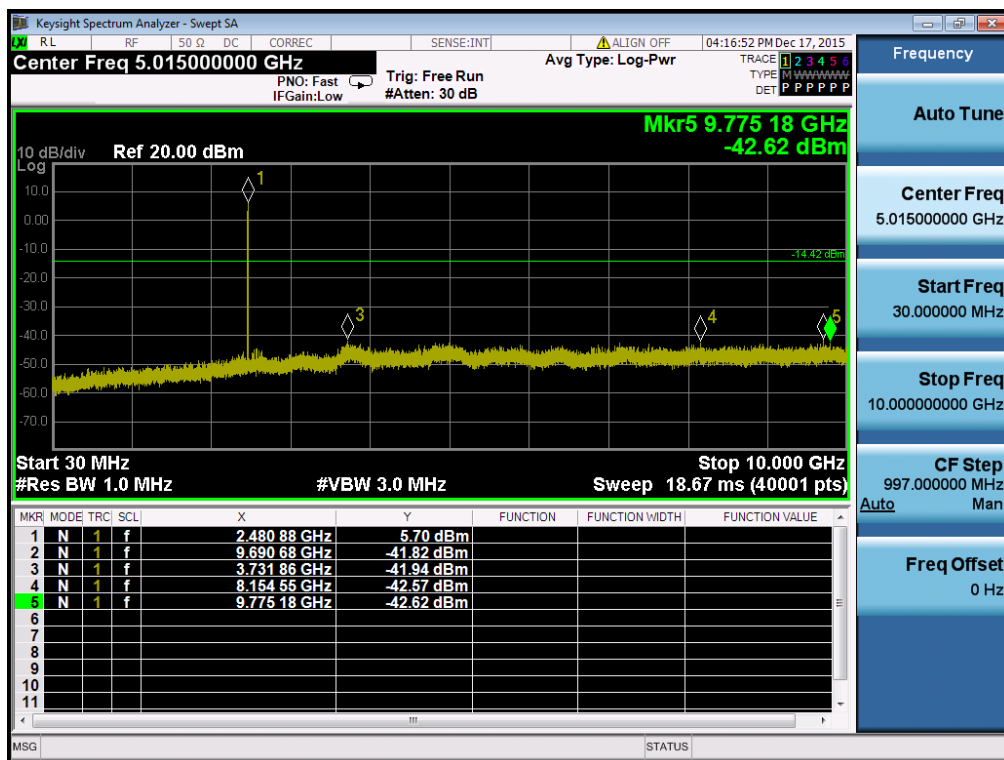
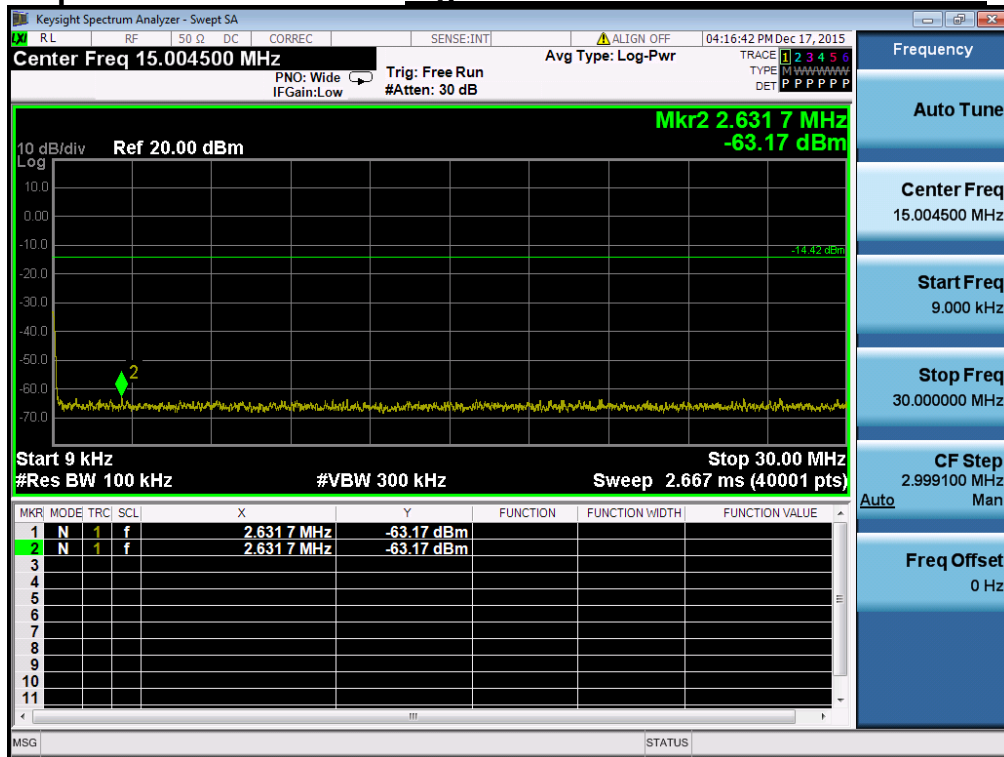

**Conducted Spurious Emissions**      *Highest Channel & Modulation : GFSK*

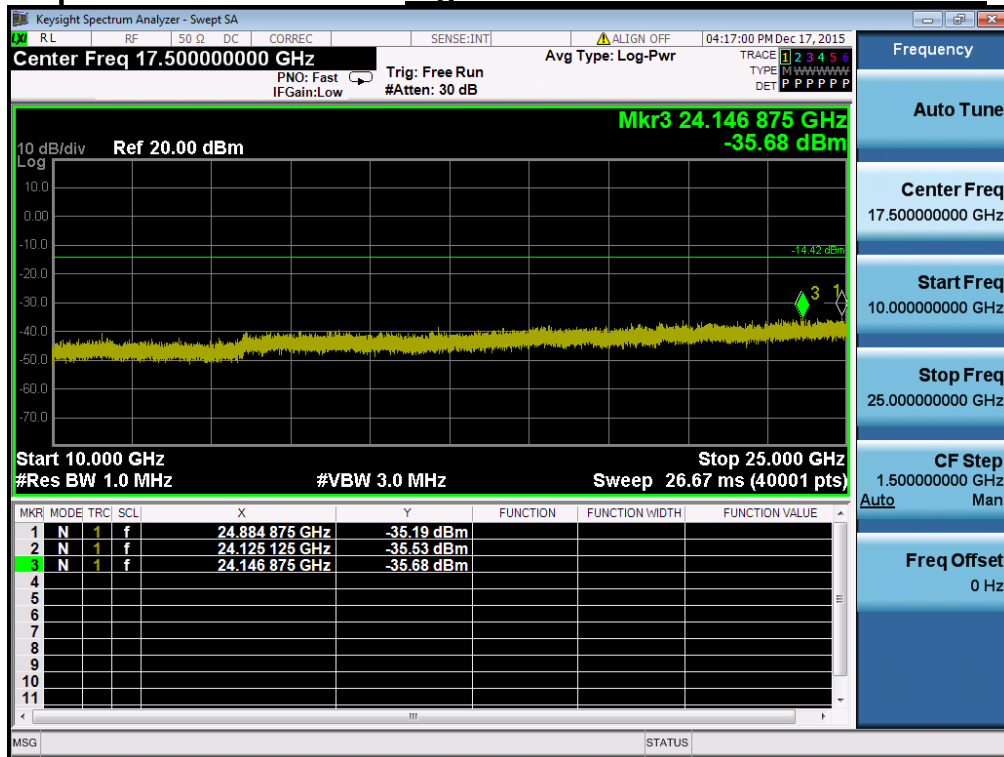

Low Band-edge

*Lowest Channel & Modulation :  $\pi/4$ DQPSK*

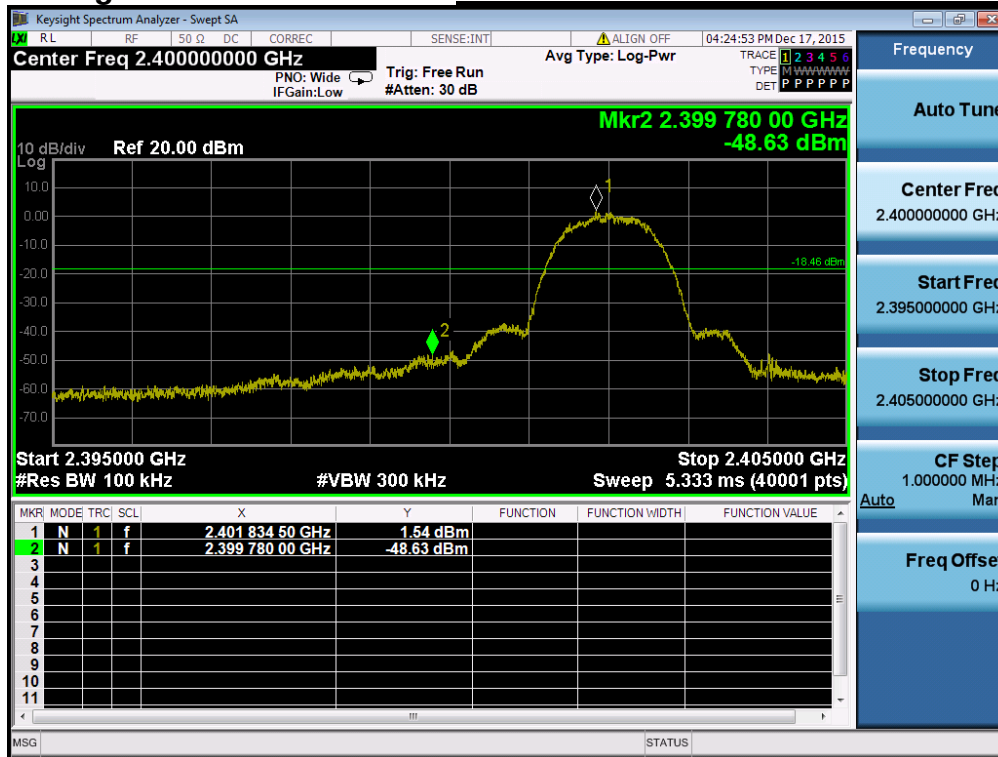

Low Band-edge

*Hopping mode & Modulation :  $\pi/4$ DQPSK*

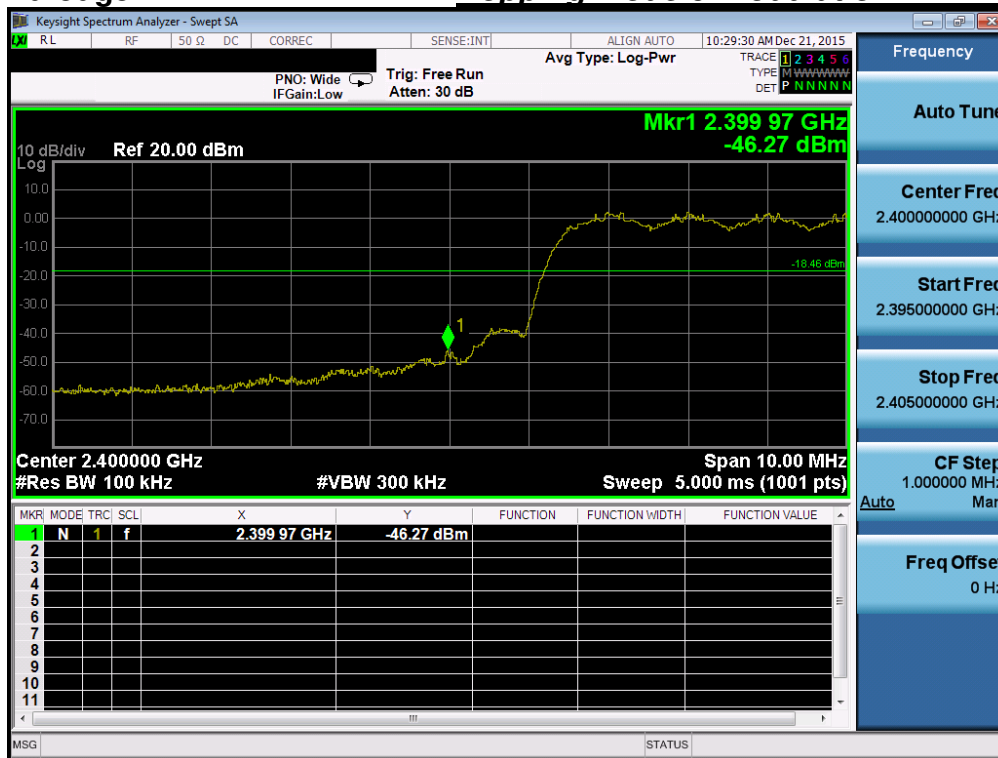

**Conducted Spurious Emissions**      **Lowest Channel & Modulation :  $\pi/4$ DQPSK**

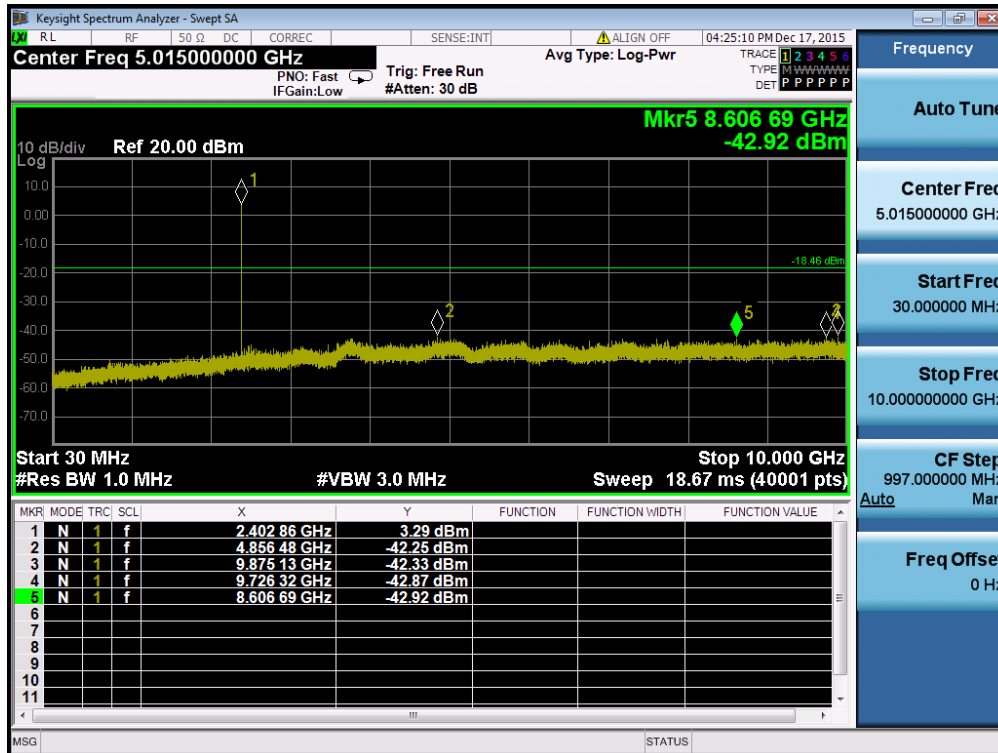
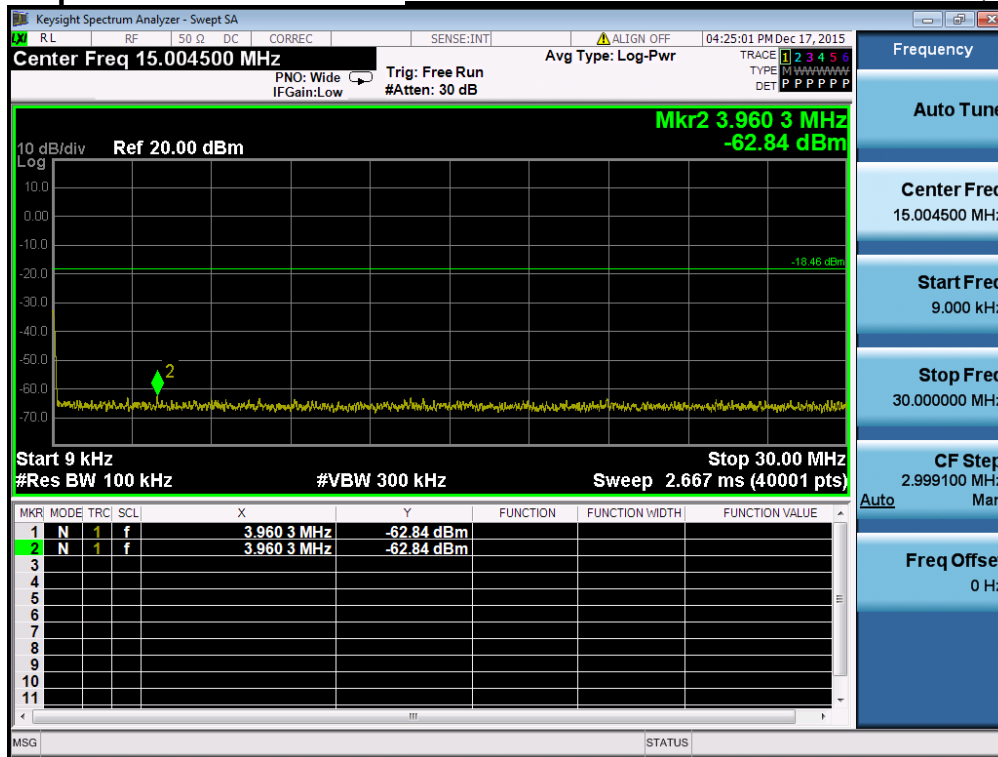

**Conducted Spurious Emissions**      **Lowest Channel & Modulation :  $\pi/4$ DQPSK**

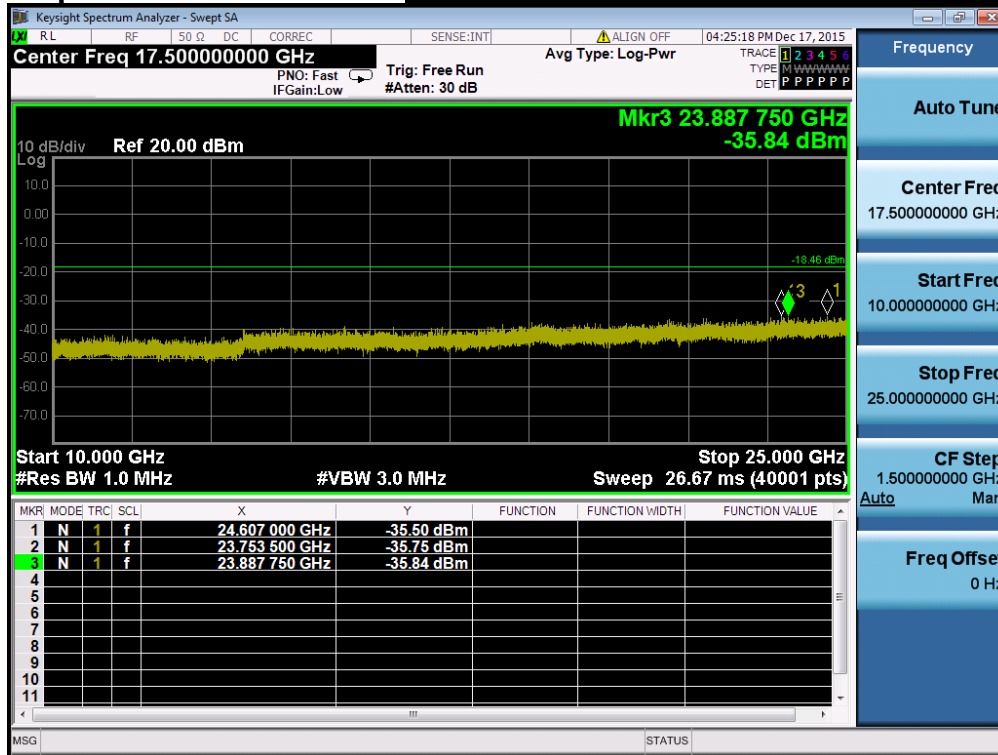

Reference for limit

Middle Channel & Modulation :  $\pi/4$ DQPSK

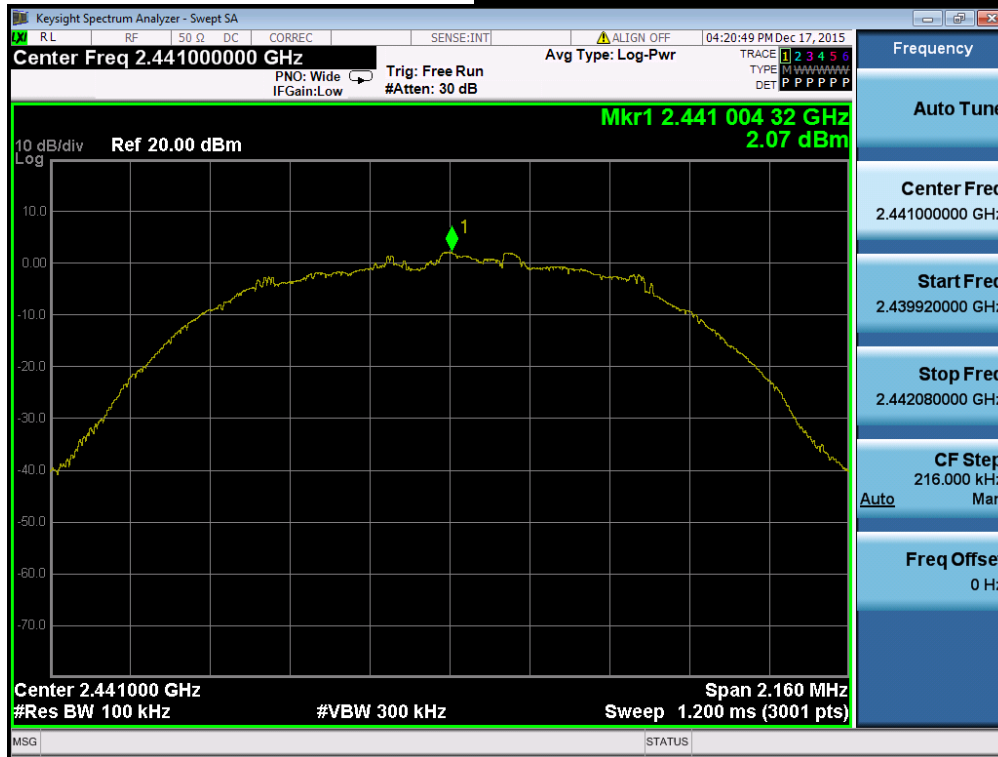

Conducted Spurious Emissions

Middle Channel & Modulation :  $\pi/4$ DQPSK

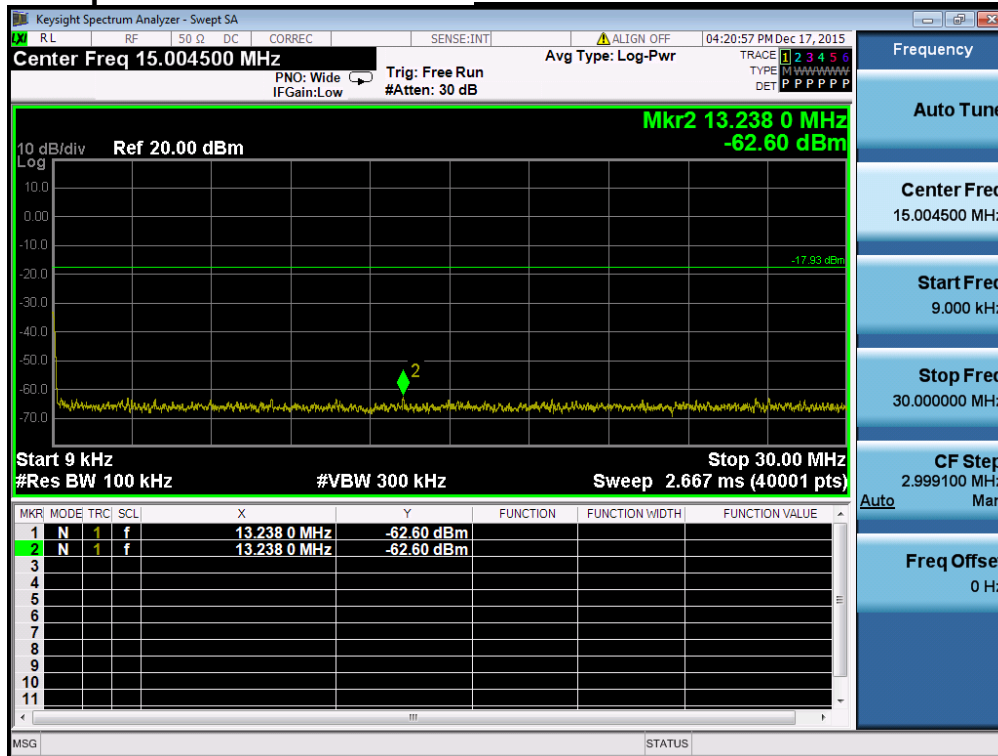

**Conducted Spurious Emissions** *Middle Channel & Modulation :  $\pi/4$ QPSK*

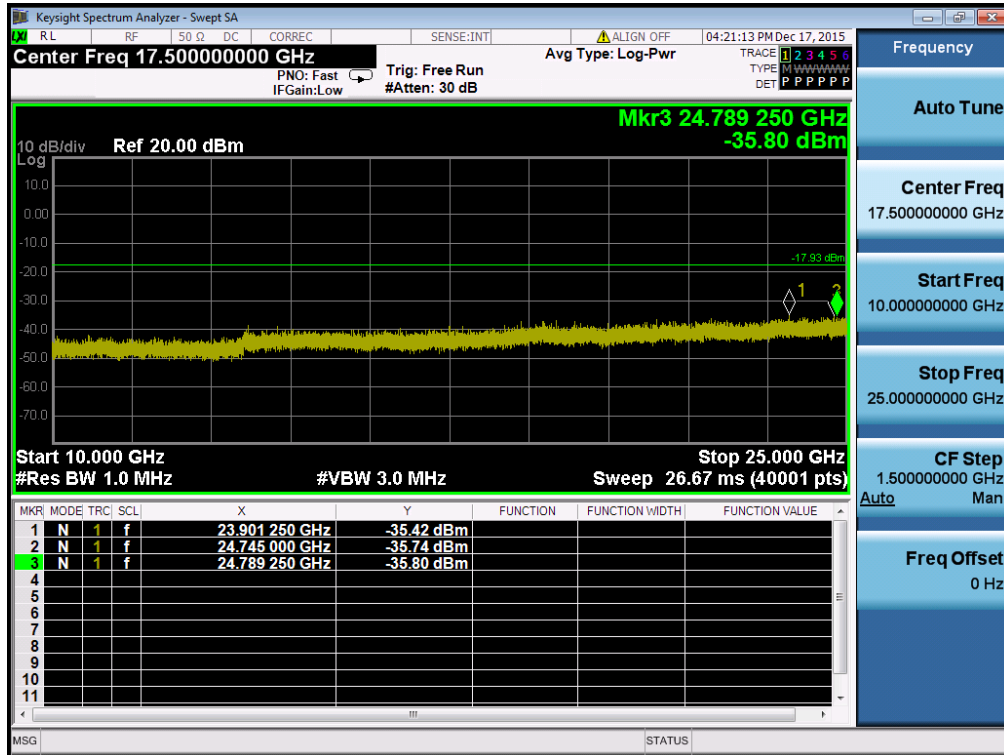
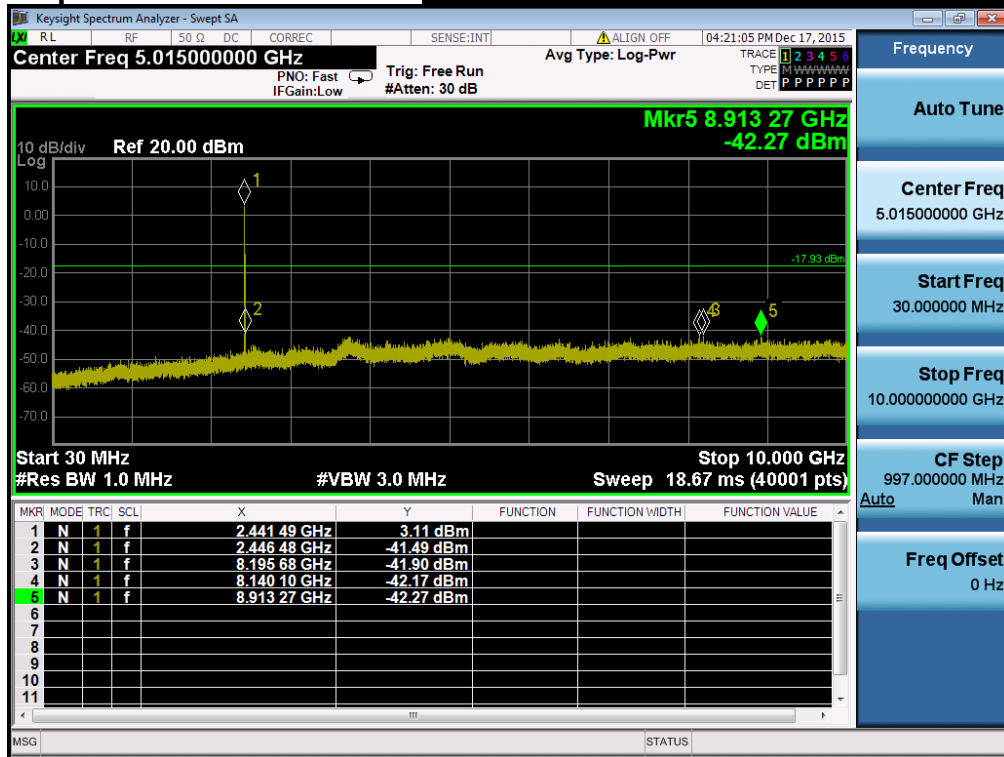

**High Band-edge**

**Highest Channel & Modulation :  $\pi/4$ DQPSK**

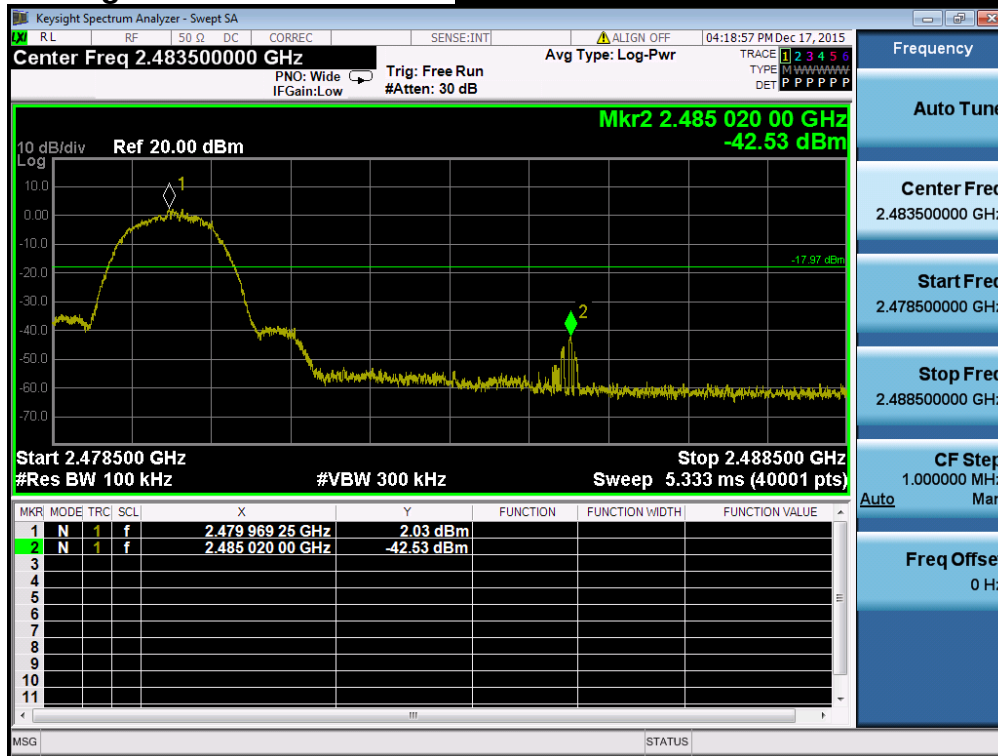

**High Band-edge**

**Hopping mode & Modulation :  $\pi/4$ DQPSK**

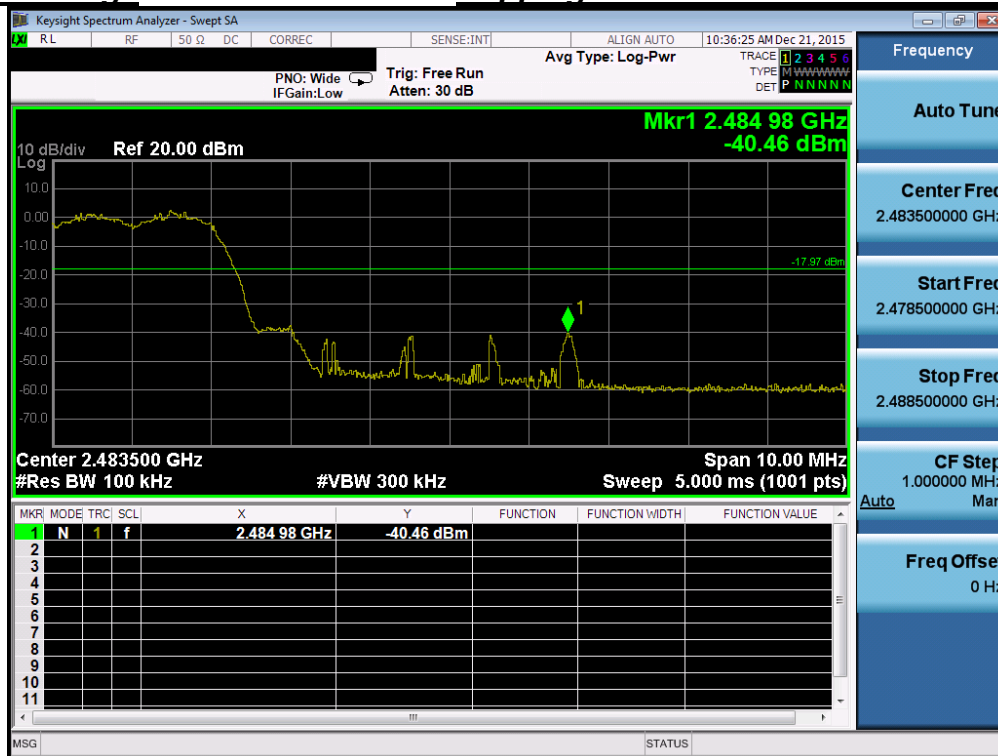

**Conducted Spurious Emissions**

**Highest Channel & Modulation :  $\pi/4$ DQPSK**

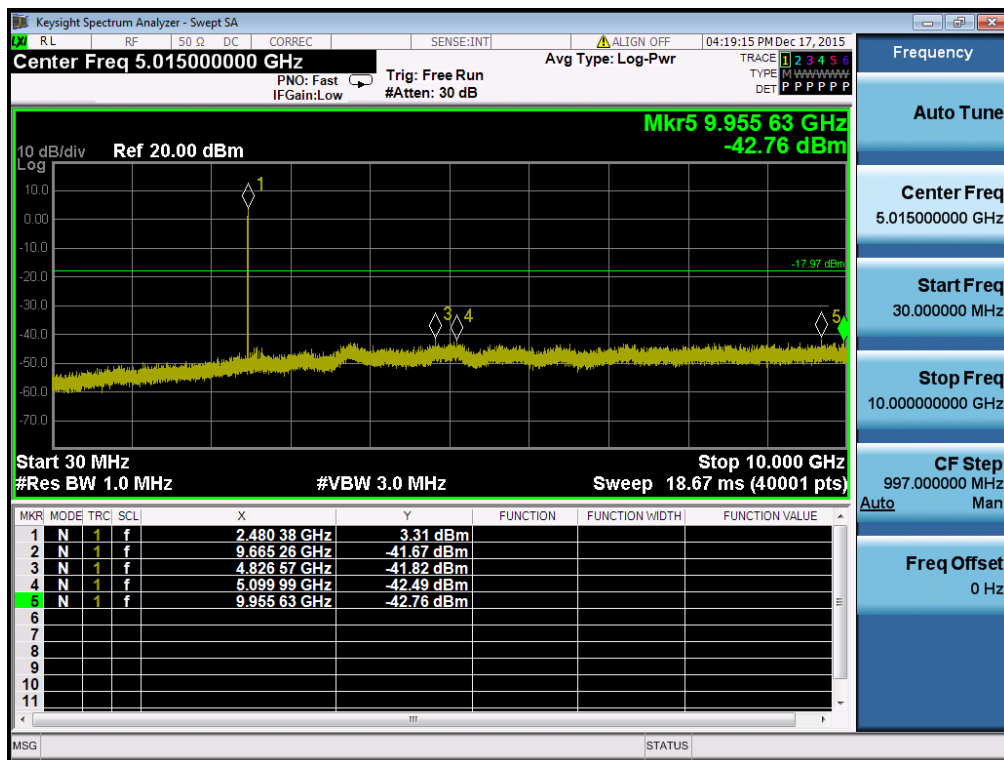
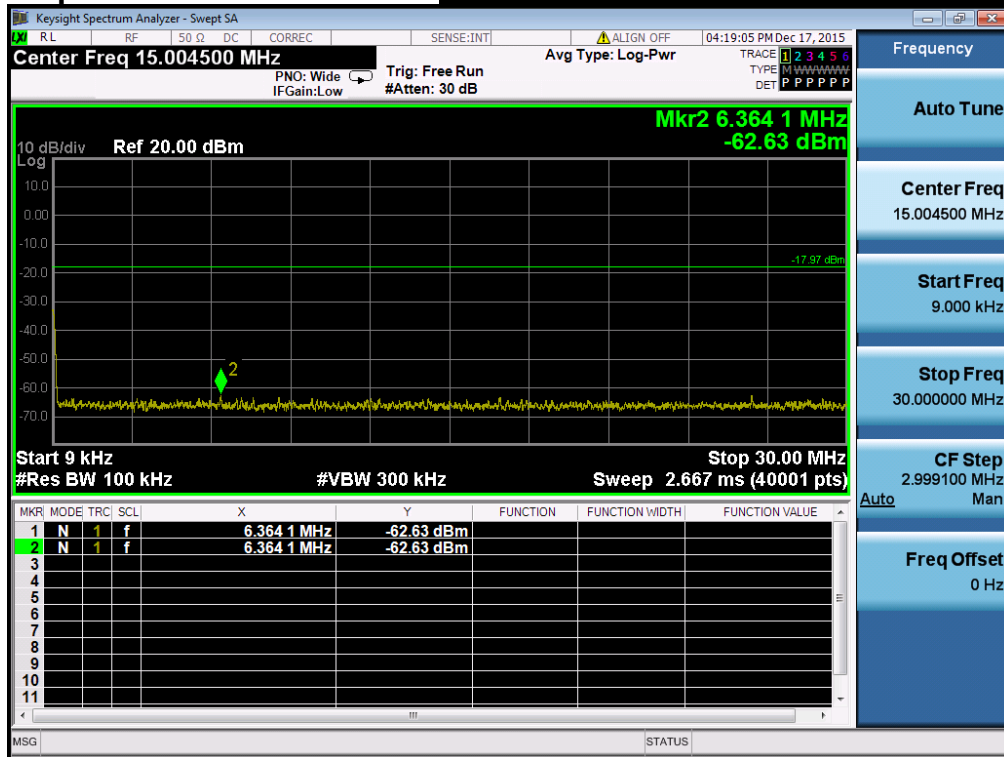

**Conducted Spurious Emissions**

***Highest Channel & Modulation :  $\pi/4$ DQPSK***

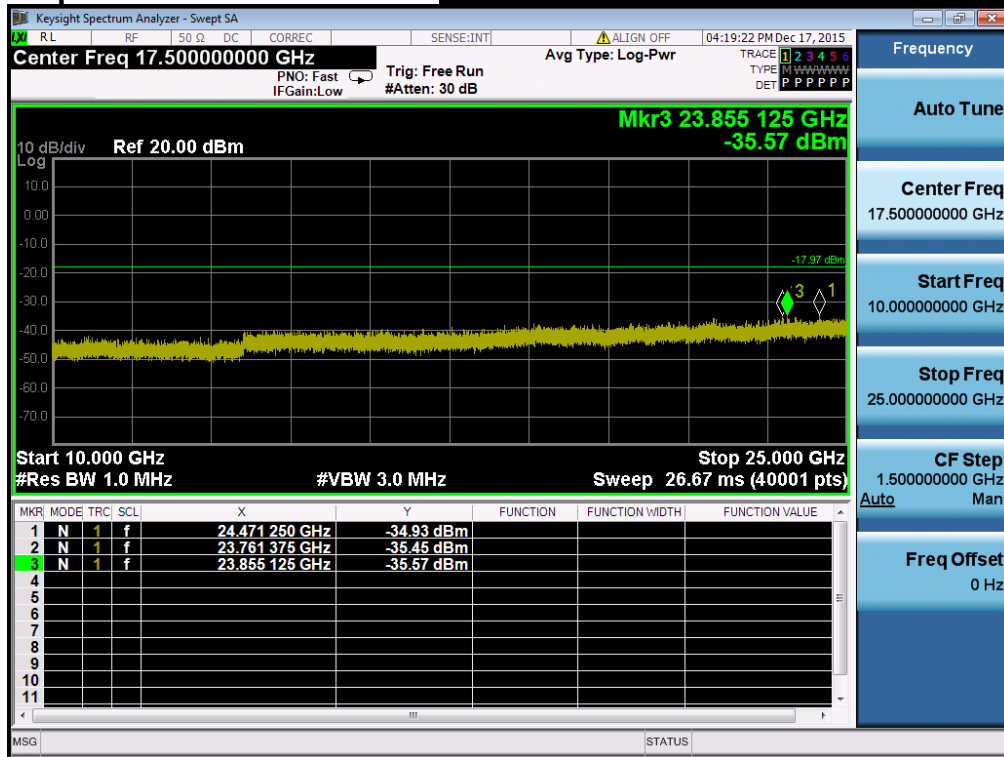

**Low Band-edge**

***Lowest Channel & Modulation : 8DPSK***

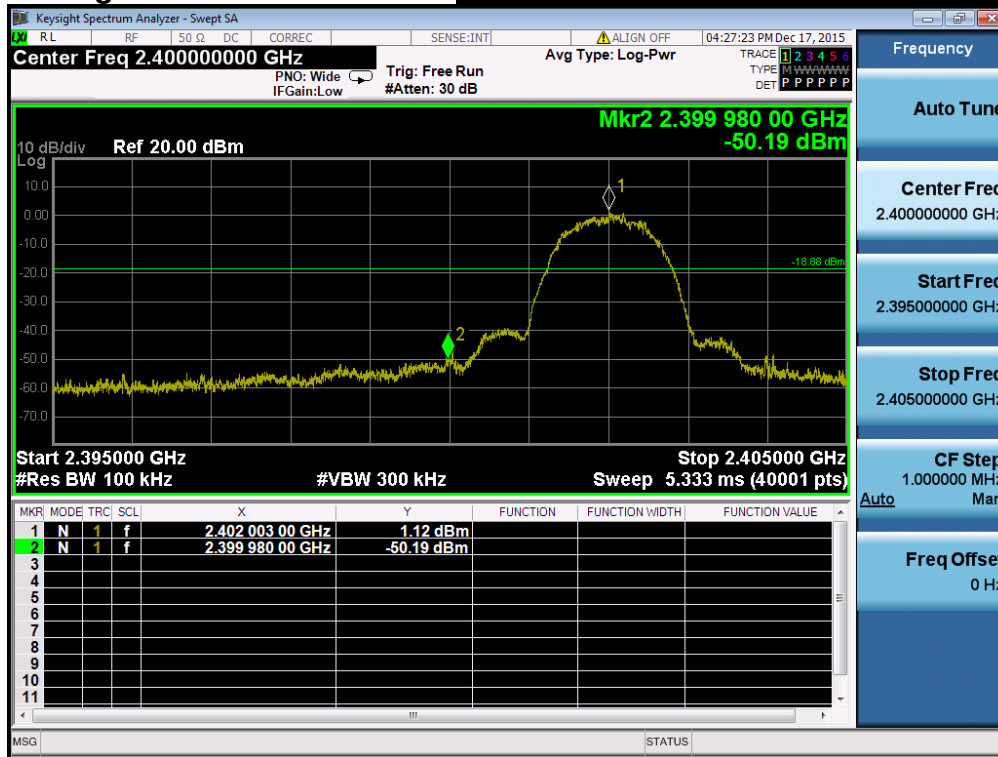

**Low Band-edge**

***Hopping mode & Modulation : 8DPSK***

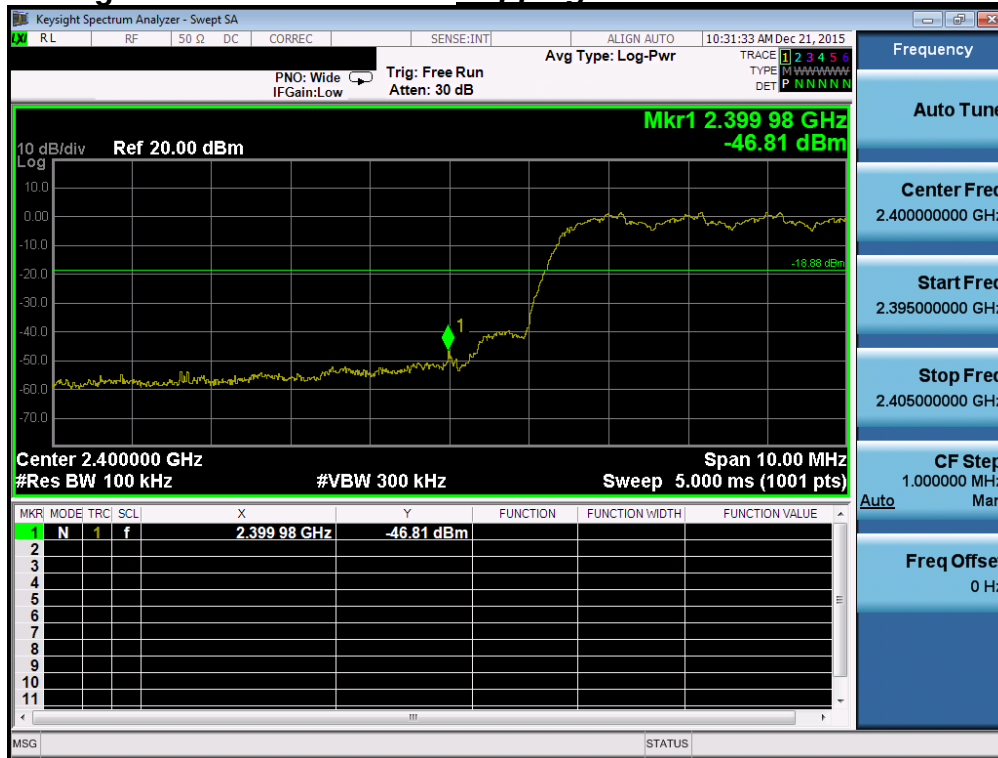

**Conducted Spurious Emissions** *Lowest Channel & Modulation : 8DPSK*

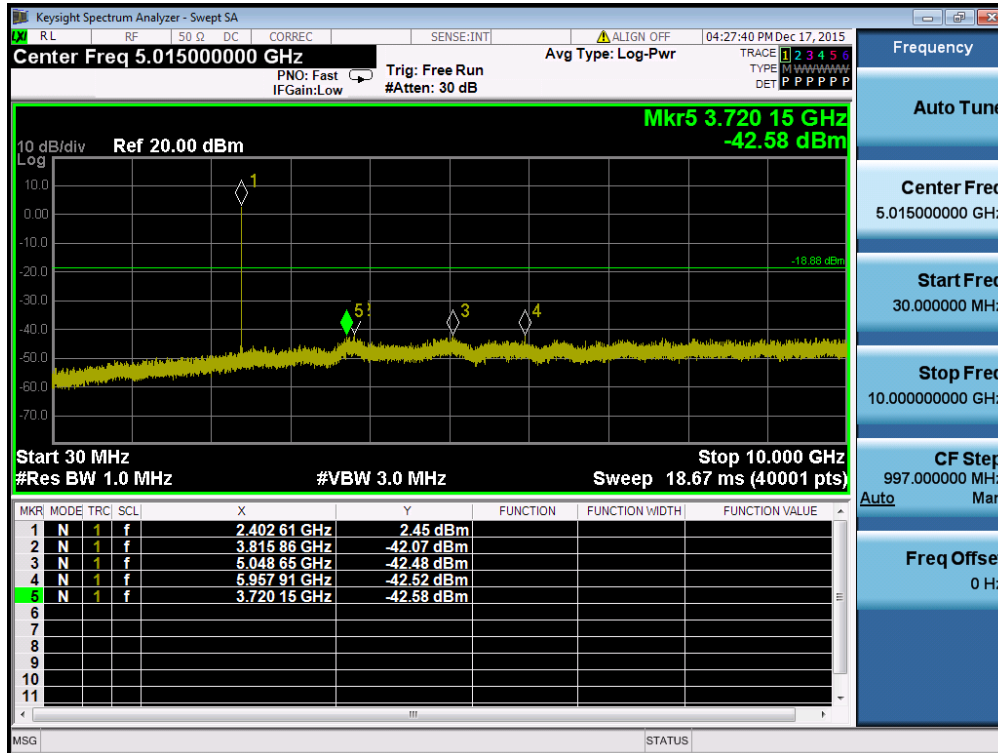
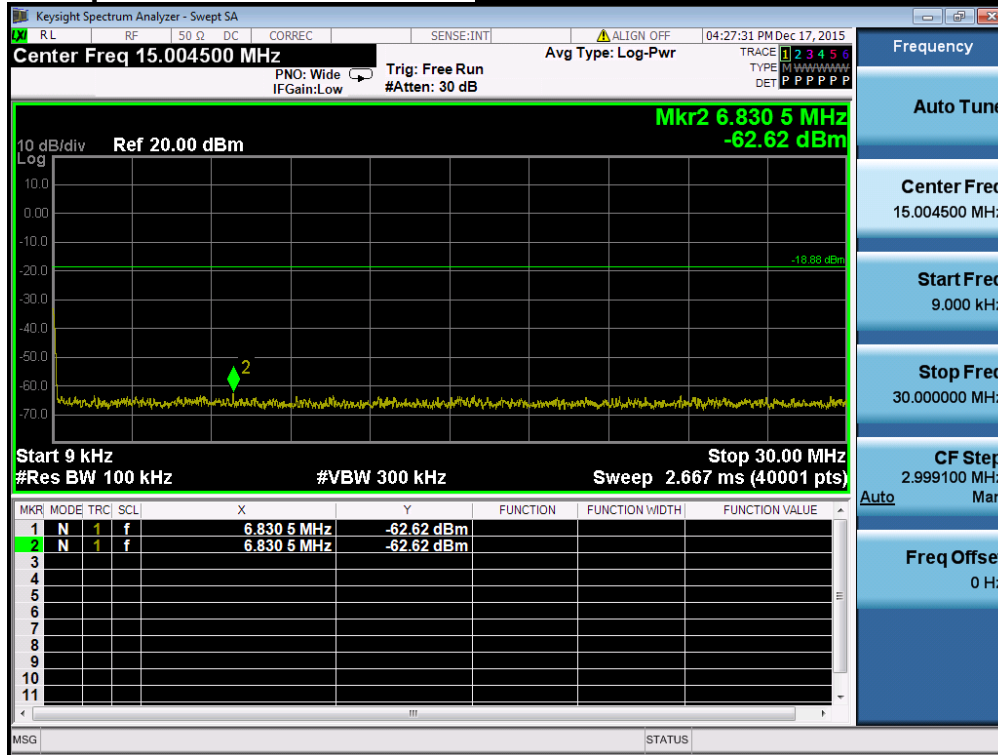



Reference for limit

Middle Channel & Modulation : 8DPSK

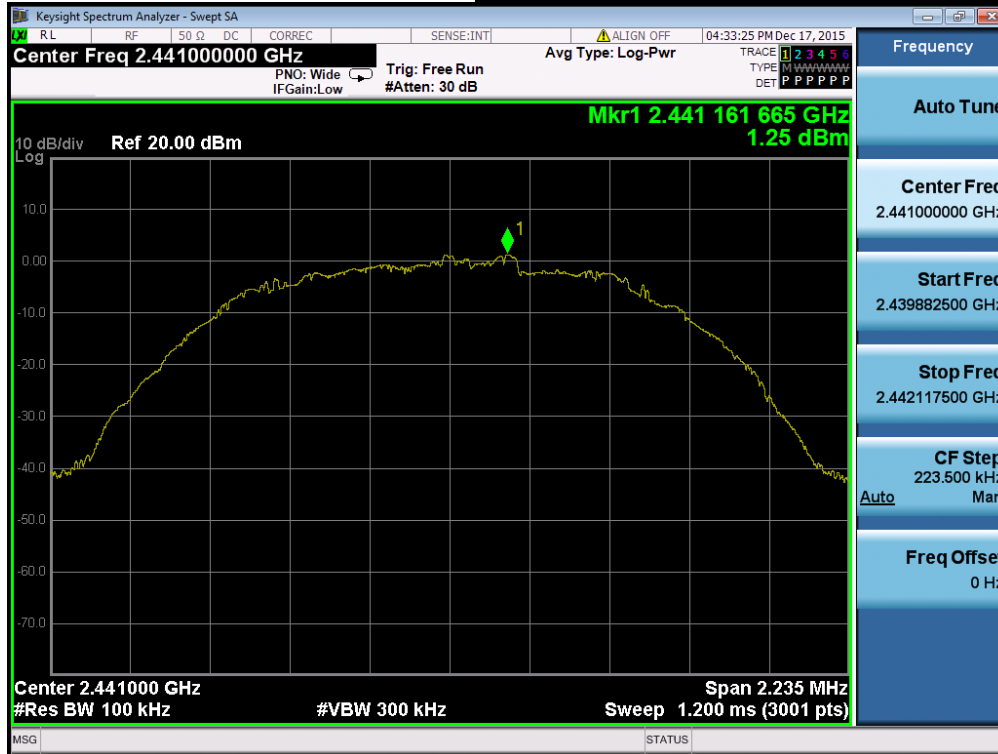

Conducted Spurious Emissions

Middle Channel & Modulation : 8DPSK

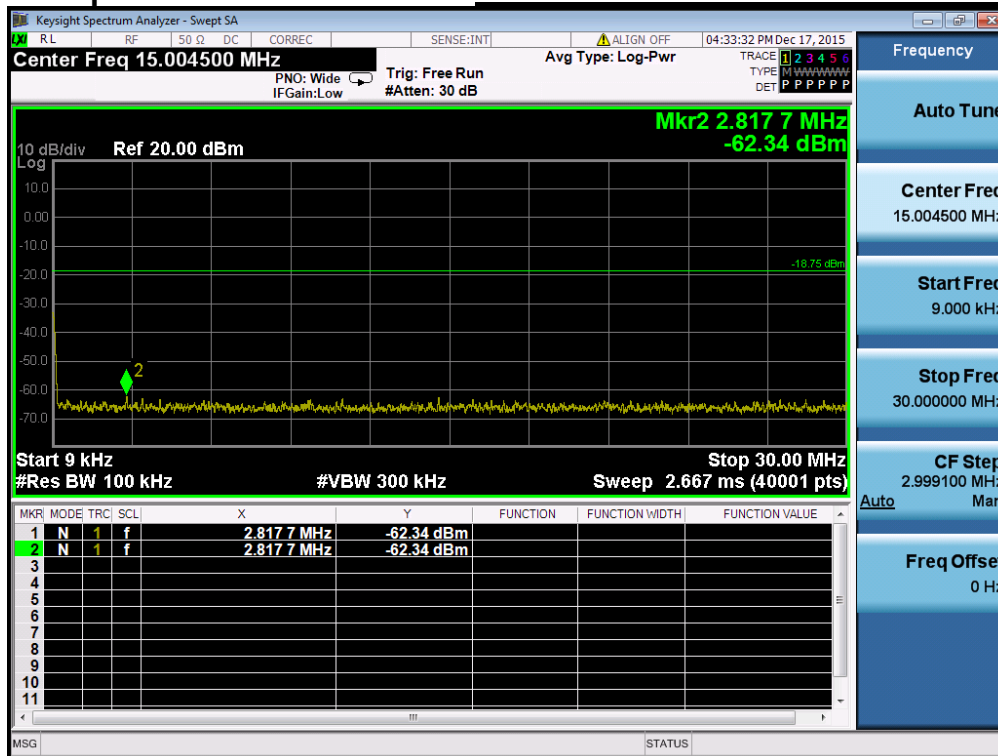

**Conducted Spurious Emissions** *Middle Channel & Modulation : 8DPSK*

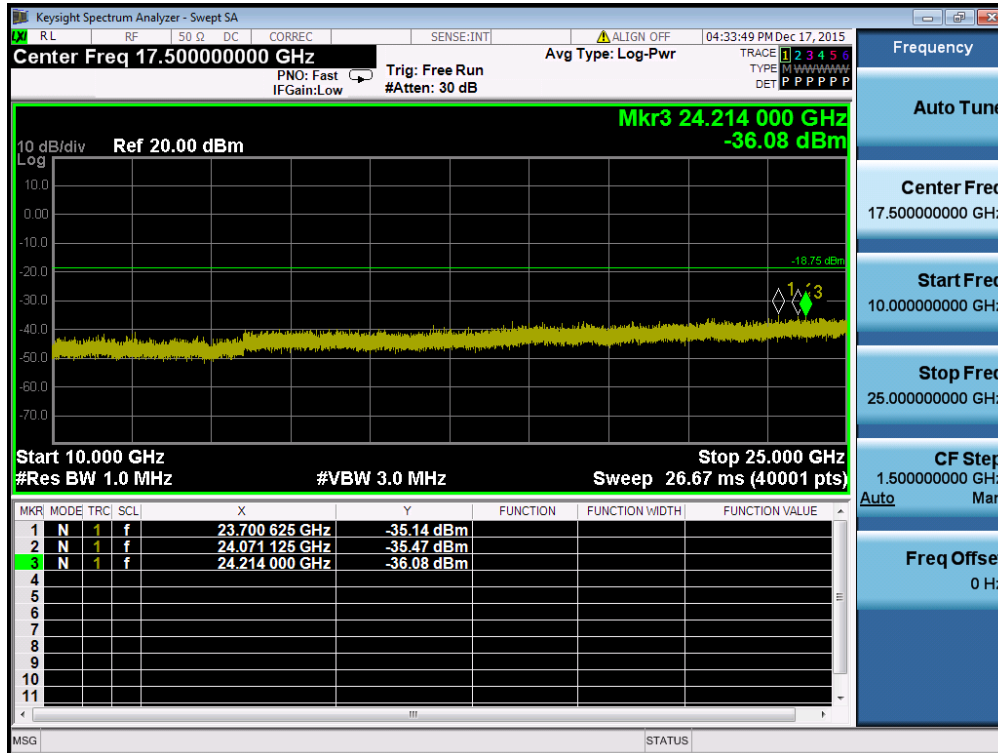
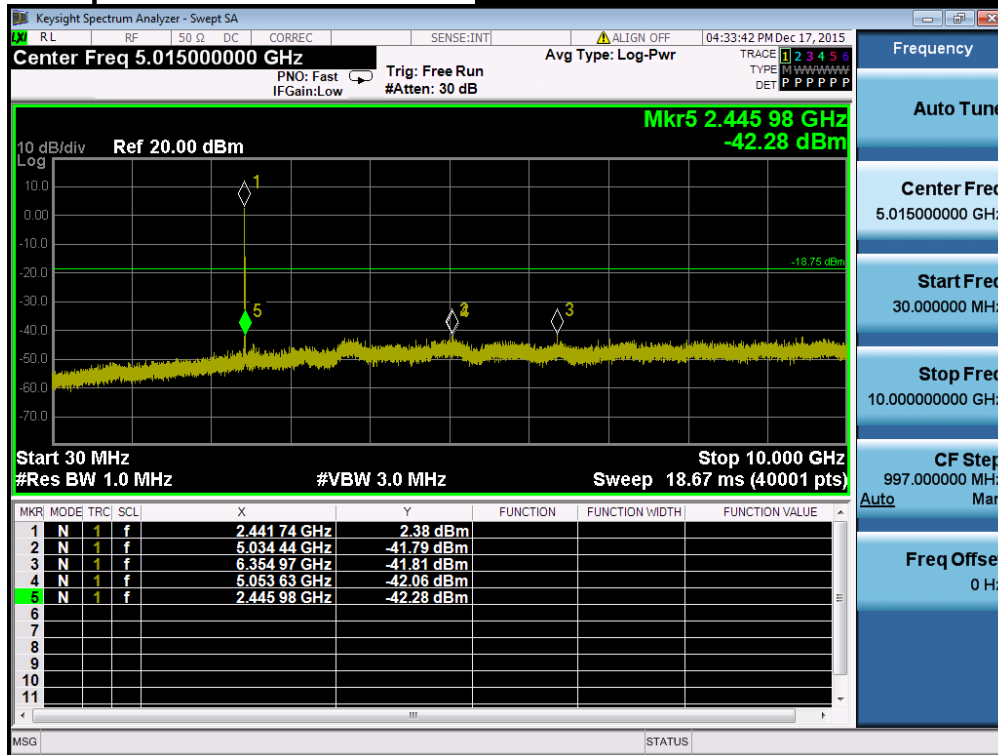

High Band-edge

Highest Channel & Modulation : 8DPSK

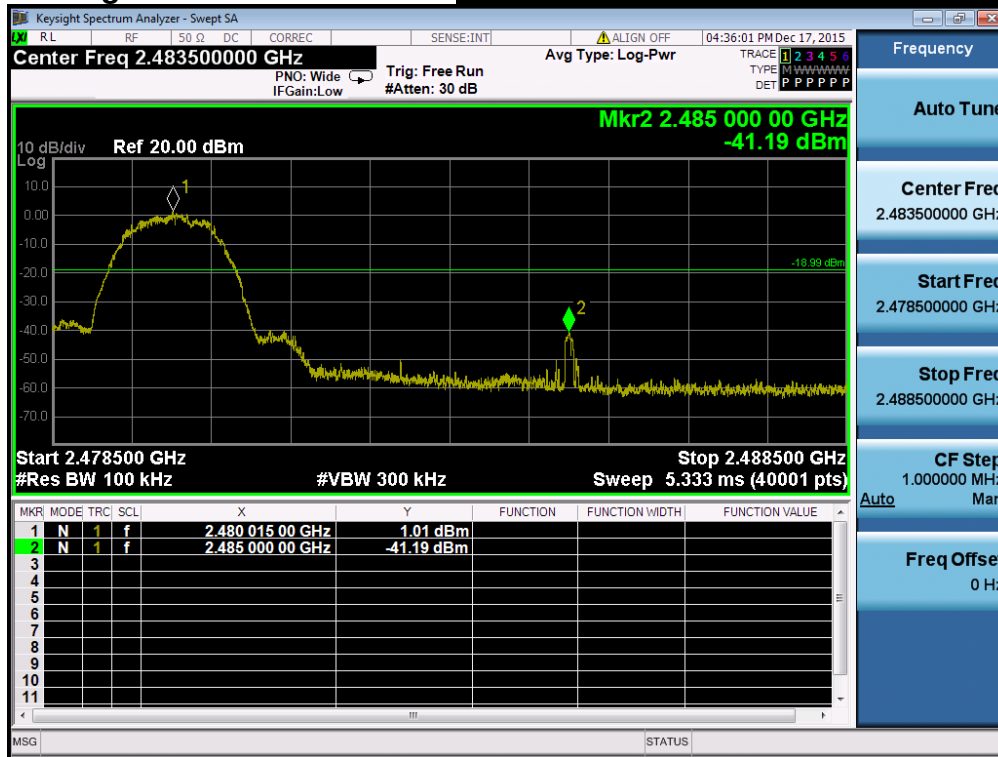

High Band-edge

Hopping mode & Modulation : 8DPSK

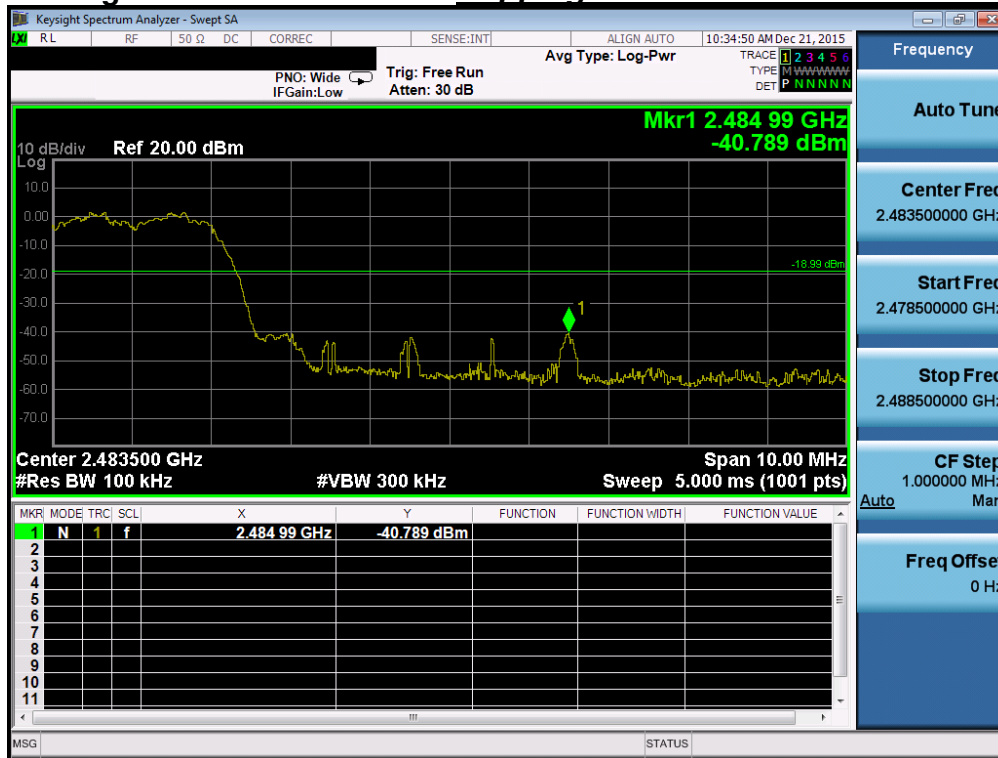

**Conducted Spurious Emissions**

***Highest Channel & Modulation : 8DPSK***

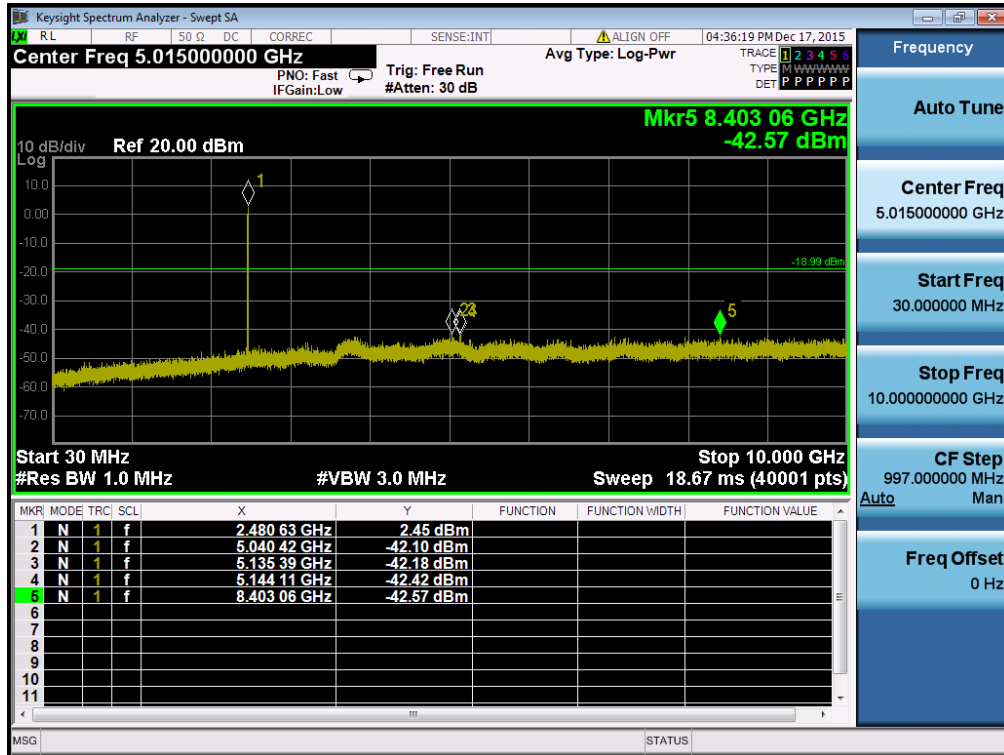
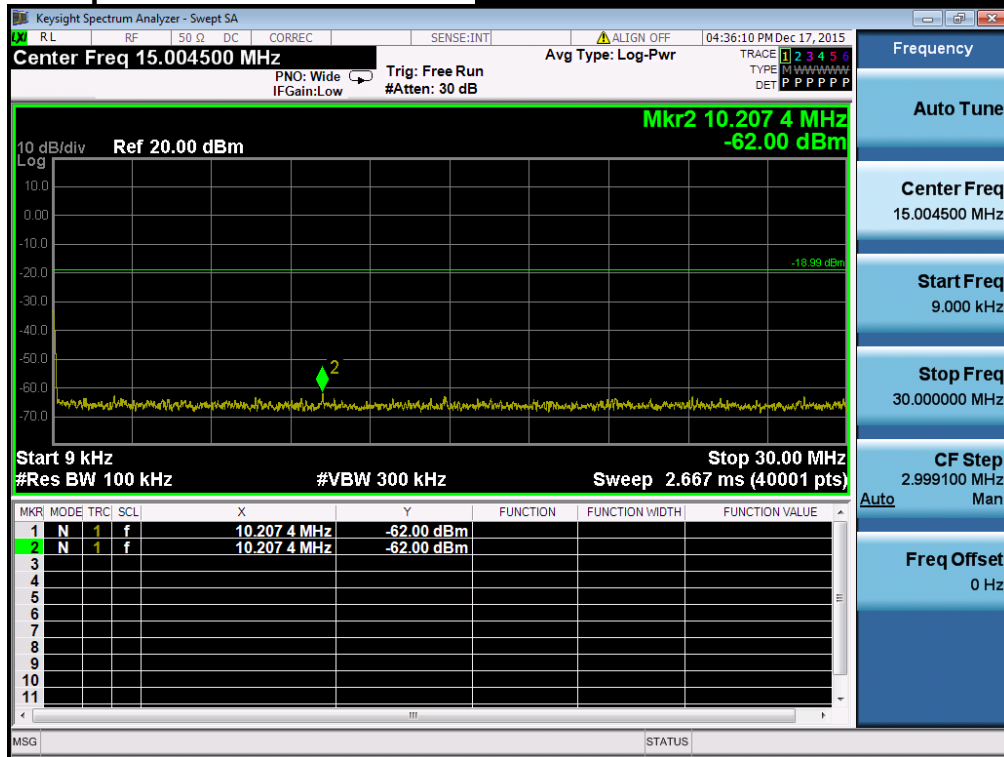

**Conducted Spurious Emissions**

***Highest Channel & Modulation : 8DPSK***

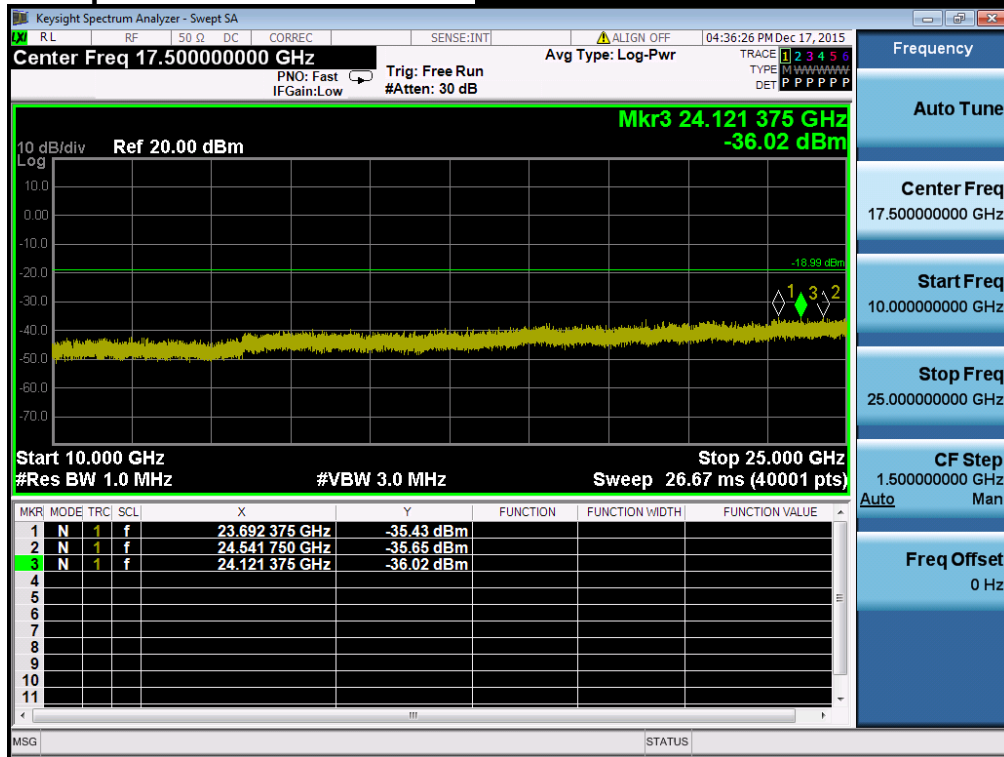

## 8. Transmitter AC Power Line Conducted Emission

### 8.1 Test Setup

Refer to test setup photo.

### 8.2 Limit

According to §15.207(a) for an intentional radiator that is designed to be connected to the public utility (AC) power line, the radio frequency voltage that is conducted back onto the AC power line on any frequency or frequencies, within the band 150 kHz to 30 MHz, shall not exceed the limits in the following table, as measured using a 50 uH/50 ohm line impedance stabilization network (LISN).

Compliance with the provision of this paragraph shall on the measurement of the radio frequency voltage between each power line and ground at the power terminal. The lower applies at the boundary between the frequency ranges.

Frequency Range (MHz)	Conducted Limit (dBuV)	
	Quasi-Peak	Average
0.15 ~ 0.5	66 to 56 *	56 to 46 *
0.5 ~ 5	56	46
5 ~ 30	60	50

\* Decreases with the logarithm of the frequency

### 8.3 Test Procedures

Conducted emissions from the EUT were measured according to the ANSI C63.10.

1. The test procedure is performed in a 6.5 m × 3.5 m × 3.5 m (L × W × H) shielded room. The EUT along with its peripherals were placed on a 1.0 m (W) × 1.5 m (L) and 0.8 m in height wooden table and the EUT was adjusted to maintain a 0.4 meter space from a vertical reference plane.
2. The EUT was connected to power mains through a line impedance stabilization network (LISN) which provides 50 ohm coupling impedance for measuring instrument and the chassis ground was bounded to the horizontal ground plane of shielded room.
3. All peripherals were connected to the second LISN and the chassis ground also bounded to the horizontal ground plane of shielded room.
4. The excess power cable between the EUT and the LISN was bundled. The power cables of peripherals were unbundled. All connecting cables of EUT and peripherals were moved to find the maximum emission.

### 8.4 Test Results

#### AC Line Conducted Emissions (Graph) = Modulation : GFSK

### Results of Conducted Emission

DTNC

Date : 2015-12-11

Order No. :  
Model No. : LG15Z96  
Serial No. : Identical prototype  
Test Condition : BT / 1Mbps

Reference No. :  
Power Supply : 120V / 60Hz  
Temp/Humi. : 21°C / 42% R.H.  
Operator : I.H.BAE

Memo : 2441MHz

LIMIT : CISPR22\_B QP  
CISPR22\_B AV

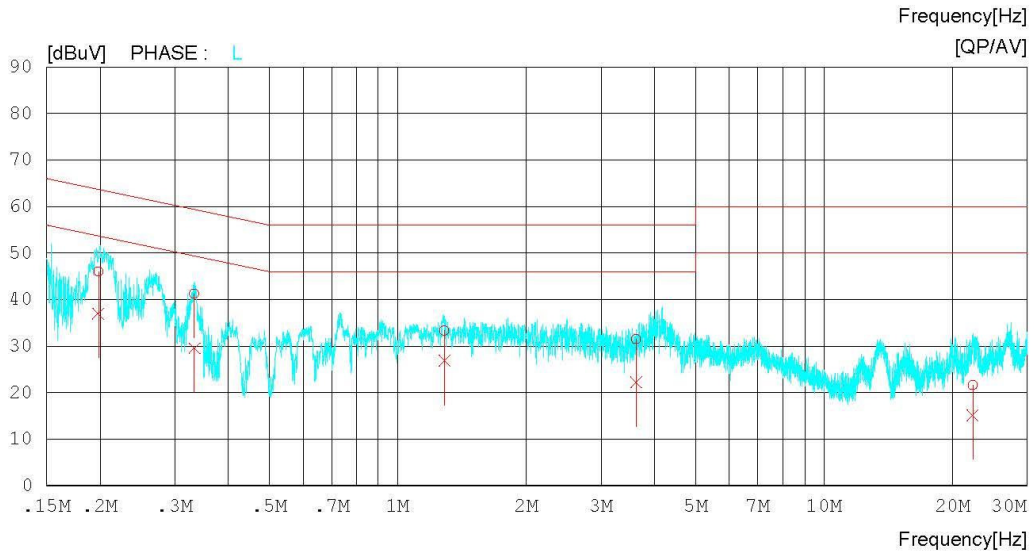
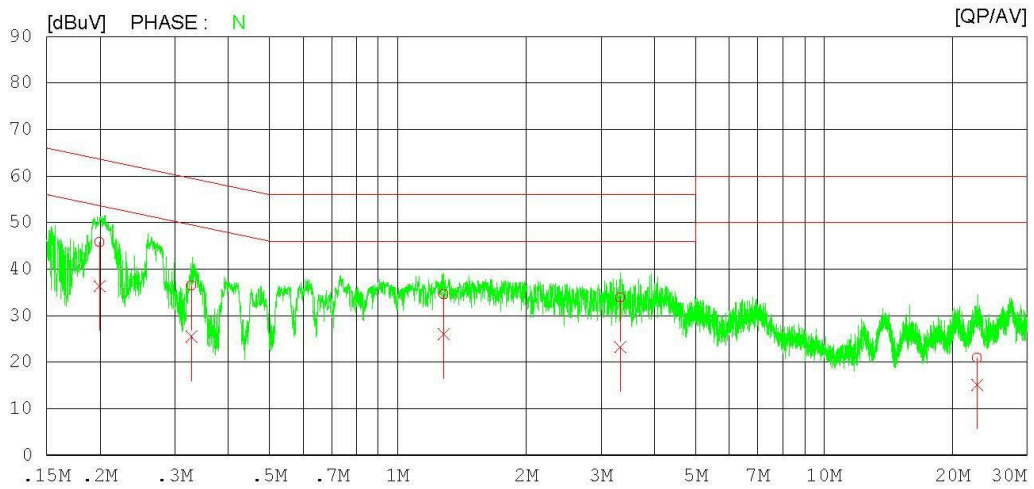

**AC Line Conducted Emissions (List) = Modulation : GFSK**

**Results of Conducted Emission**

DTNC

Date : 2015-12-11

Order No.	:		Reference No.	:	
Model No.	:	LG15Z96	Power Supply	:	120V / 60Hz
Serial No.	:	Identical prototype	Temp/Humi.	:	21 'C / 42 % R.H.
Test Condition	:	BT / 1Mbps	Operator	:	I.H.BAE
Memo	:	2441MHz			

LIMIT : CISPR22\_B QP  
CISPR22\_B AV

NO	FREQ [MHz]	READING		C. FACTOR [dB]	RESULT		LIMIT		MARGIN		PHASE
		QP [dBuV]	AV [dBuV]		QP [dBuV]	AV [dBuV]	QP [dBuV]	AV [dBuV]	QP [dBuV]	AV [dBuV]	
1	0.19962	35.7	26.3	10.1	45.8	36.4	63.6	53.6	17.8	17.2	N
2	0.32802	26.4	15.4	10.1	36.5	25.5	59.5	49.5	23.0	24.0	N
3	1.28300	24.4	15.7	10.2	34.6	25.9	56.0	46.0	21.4	20.1	N
4	3.32760	23.7	13.0	10.2	33.9	23.2	56.0	46.0	22.1	22.8	N
5	22.88380	10.0	4.2	10.9	20.9	15.1	60.0	50.0	39.1	34.9	N
6	0.19831	35.9	26.9	10.1	46.0	37.0	63.7	53.7	17.7	16.7	L
7	0.33312	31.1	19.4	10.1	41.2	29.5	59.4	49.4	18.2	19.9	L
8	1.28500	23.1	16.6	10.2	33.3	26.8	56.0	46.0	22.7	19.2	L
9	3.62920	21.2	12.0	10.2	31.4	22.2	56.0	46.0	24.6	23.8	L
10	22.33240	10.6	4.1	11.0	21.6	15.1	60.0	50.0	38.4	34.9	L

## 9. Antenna Requirement

Describe how the EUT complies with the requirement that either its antenna is permanently attached, or that it employs a unique antenna connector, for every antenna proposed for use with the EUT.

**Conclusion: Comply**

**The EUT used two non standard antenna connectors.**

**- Minimum Standard :**

An intentional radiator shall be designed to ensure that no antenna other than that furnished by the responsible party shall be used with the device. The use of a permanently attached antenna or of an antenna that uses a unique coupling to the intentional radiator shall be considered sufficient to comply with the provisions.
--

## 10. Occupied Bandwidth (99 %)

### 10.1 Test Setup

Refer to the APPENDIX I.

### 10.2 Limit

Limit : Not Applicable

### 10.3 Test Procedure

The 99 % power bandwidth was measured with a calibrated spectrum analyzer.

The resolution bandwidth (RBW) shall be in the range of 1 % to 5 % of the occupied bandwidth (OBW) and video bandwidth (VBW) shall be approximately  $3 \times$  RBW.

Spectrum analyzer plots are included on the following pages.

### 10.4 Test Results

Test Mode	Tested Channel	Test Results (MHz)
<b><u>GFSK</u></b>	Lowest	0.869
	Middle	0.873
	Highest	0.880
<b><u><math>\pi/4</math>DQPSK</u></b>	Lowest	1.353
	Middle	1.353
	Highest	1.351
<b><u>8DPSK</u></b>	Lowest	1.351
	Middle	1.352
	Highest	1.350

**Occupied Bandwidth (99 %)**

***Lowest Frequency & GFSK***

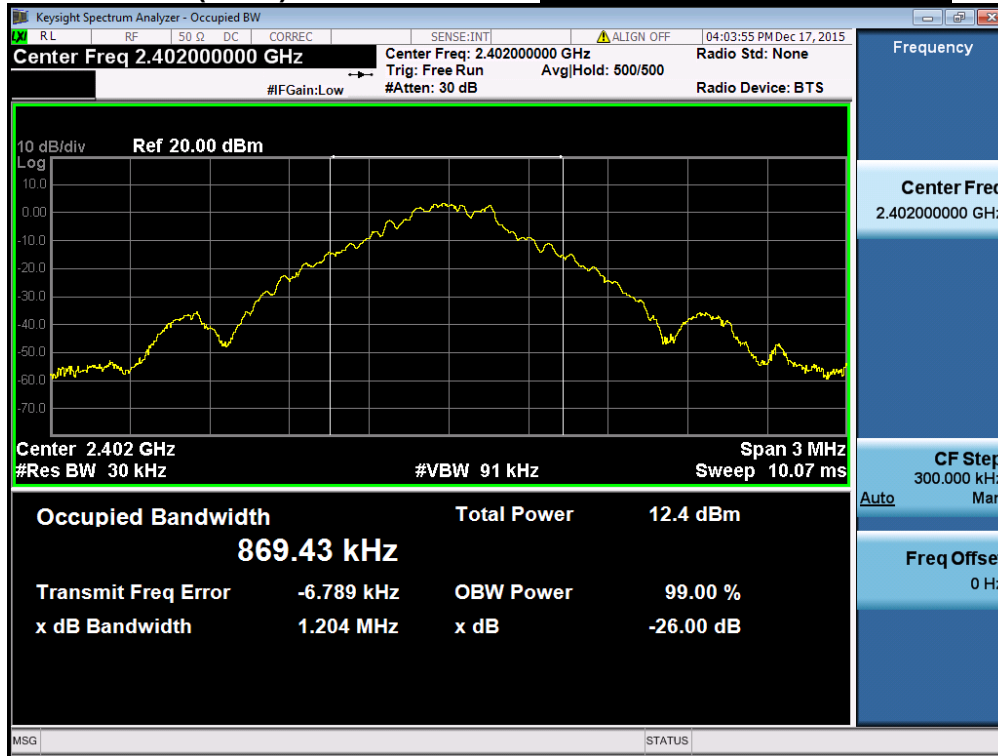

**Occupied Bandwidth (99 %)**

***Middle Frequency & GFSK***

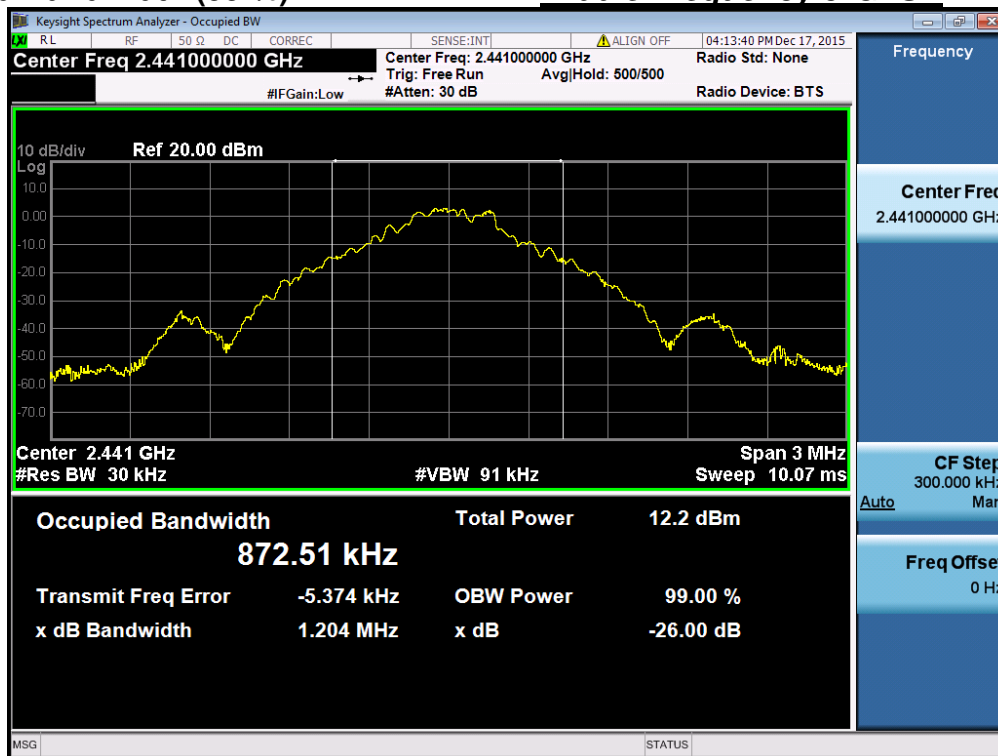

**Occupied Bandwidth (99 %)**

**Highest Frequency & GFSK**

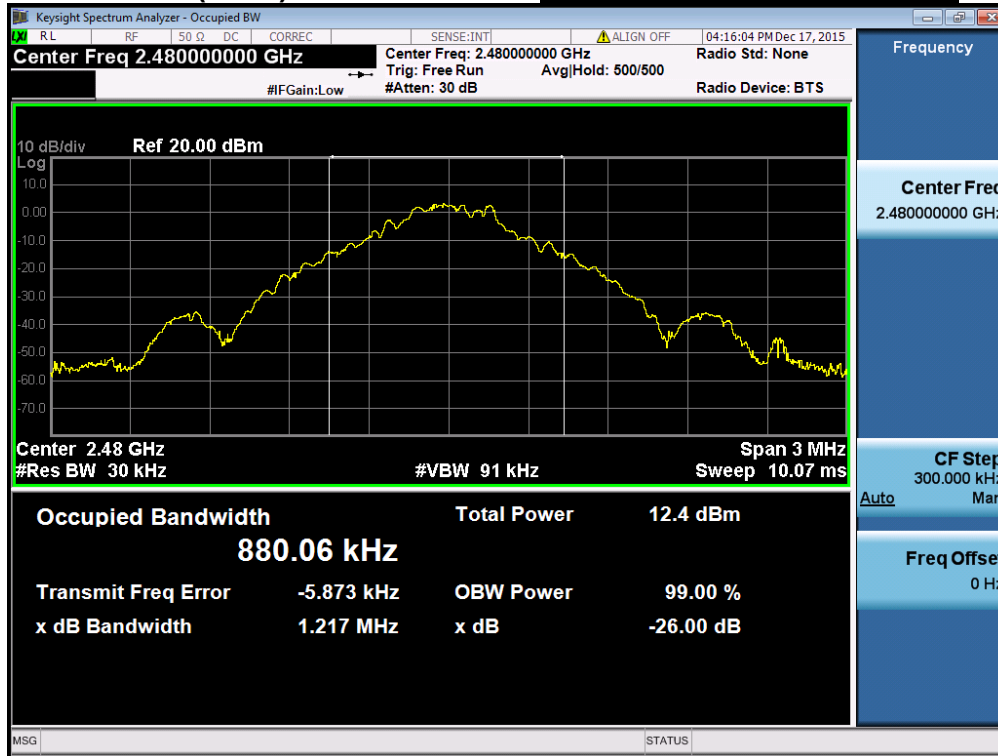

**Occupied Bandwidth (99 %)**

***Lowest Frequency &  $\pi/4$  DQPSK***

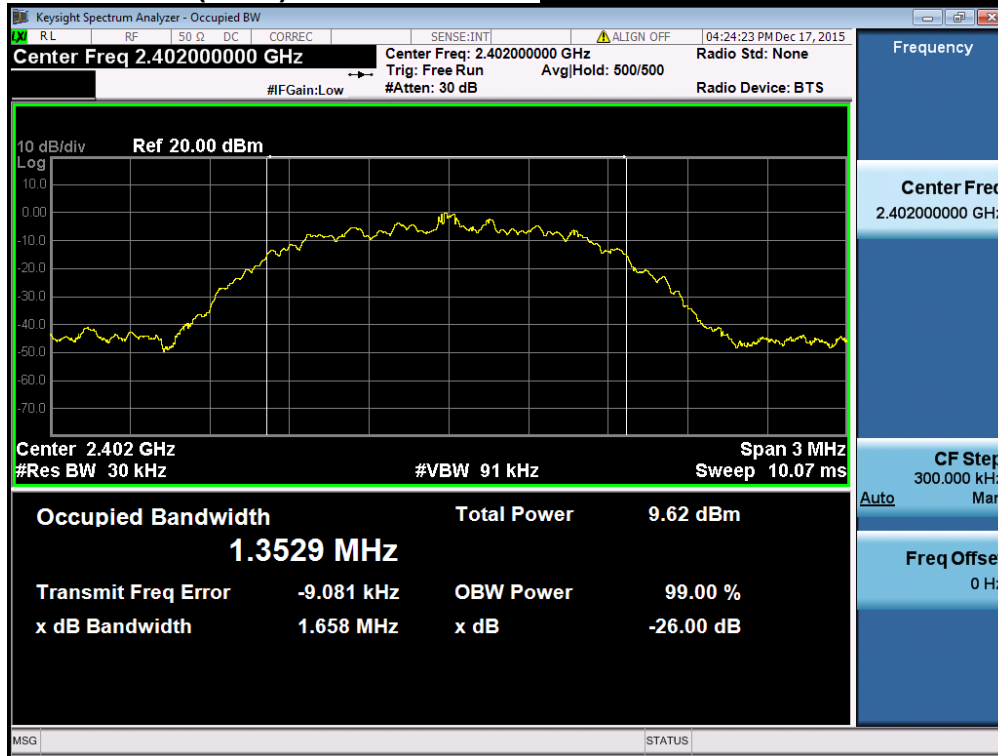

**Occupied Bandwidth (99 %)**

***Middle Frequency &  $\pi/4$  DQPSK***

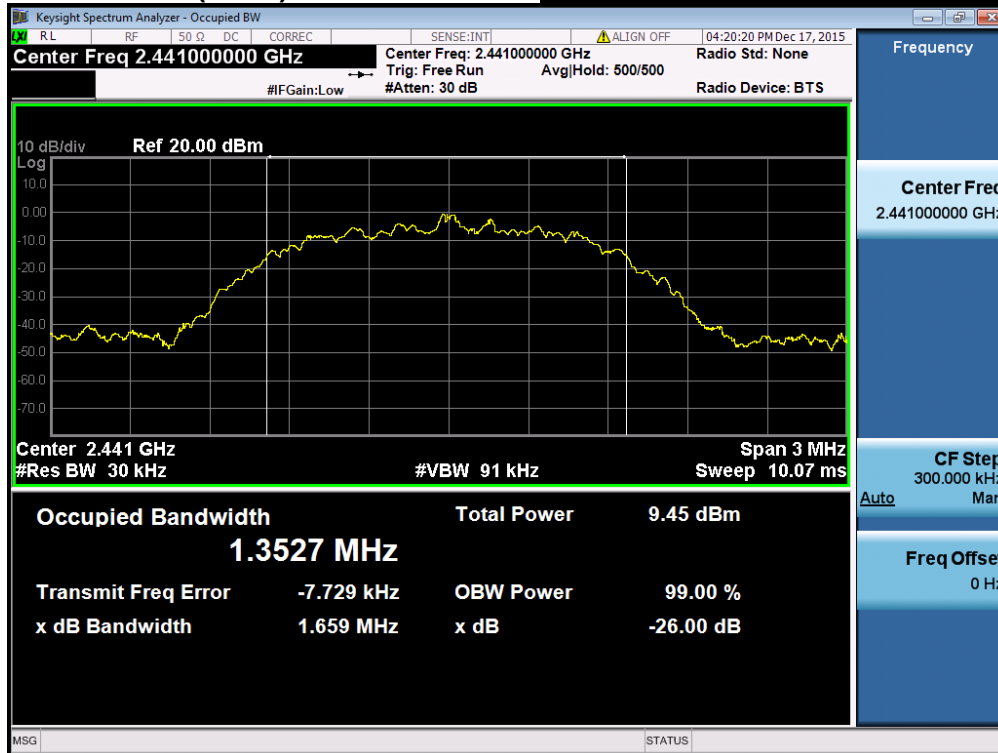

**Occupied Bandwidth (99 %)**

***Highest Frequency &  $\pi/4$  DQPSK***

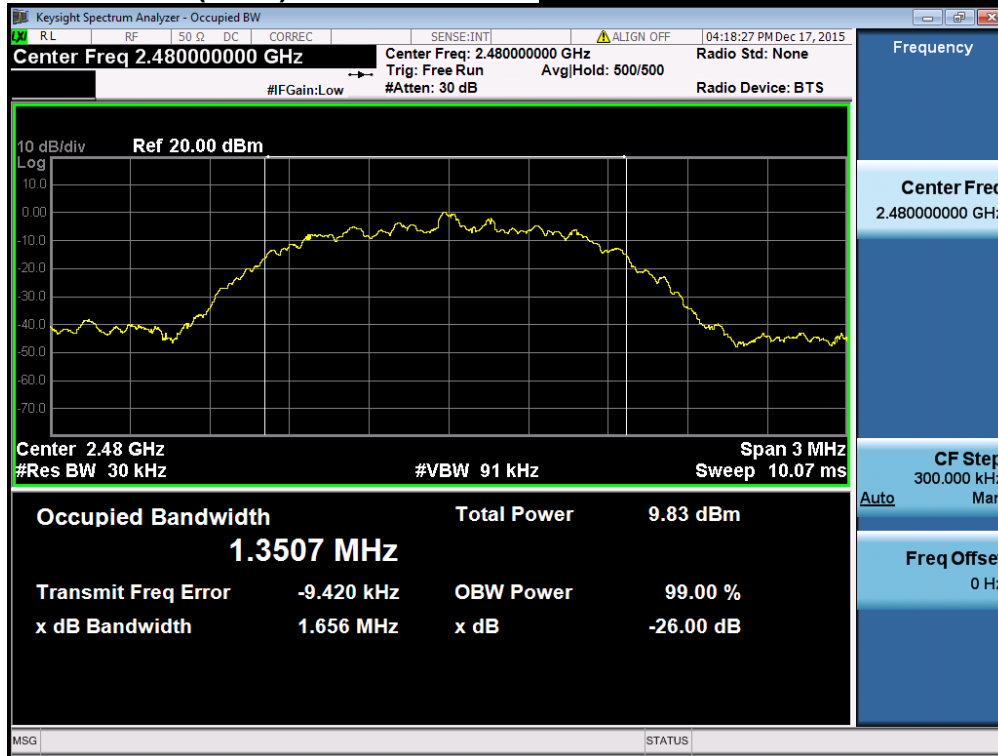

**Occupied Bandwidth (99 %)**

***Lowest Frequency & 8DPSK***

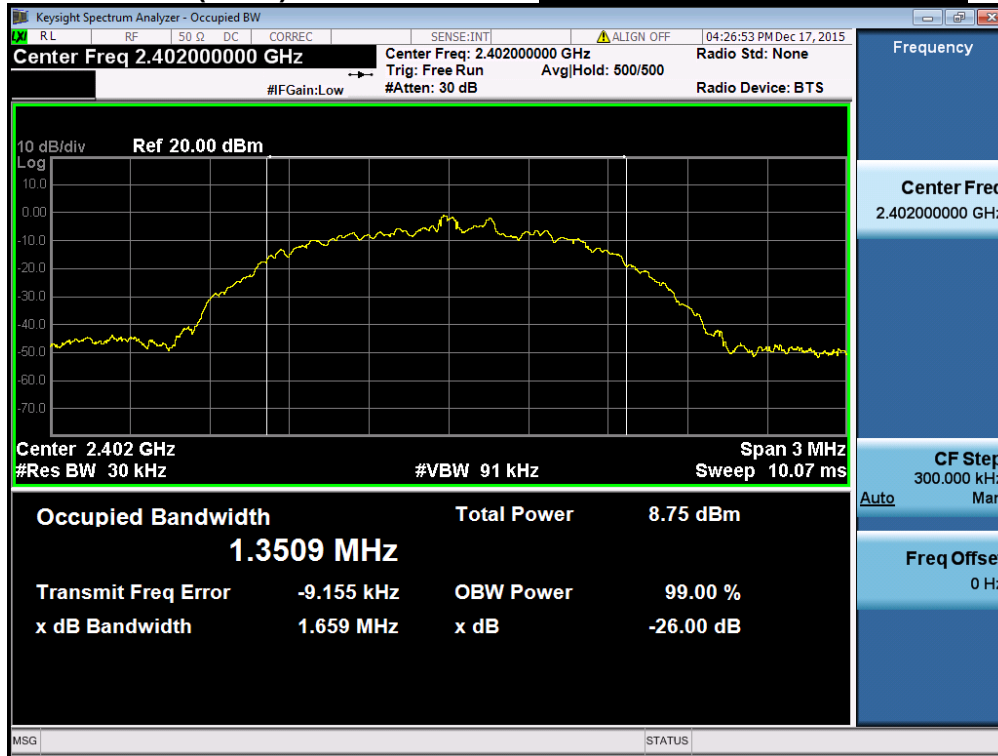

**Occupied Bandwidth (99 %)**

***Middle Frequency & 8DPSK***

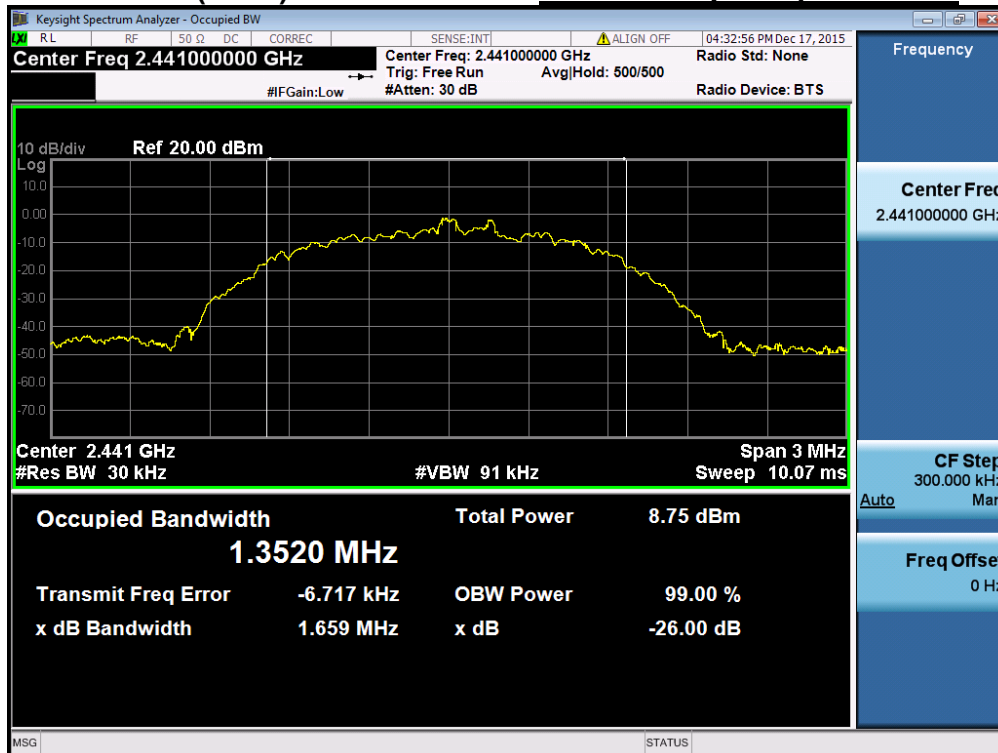

**Occupied Bandwidth (99 %)**

***Highest Frequency & 8DPSK***

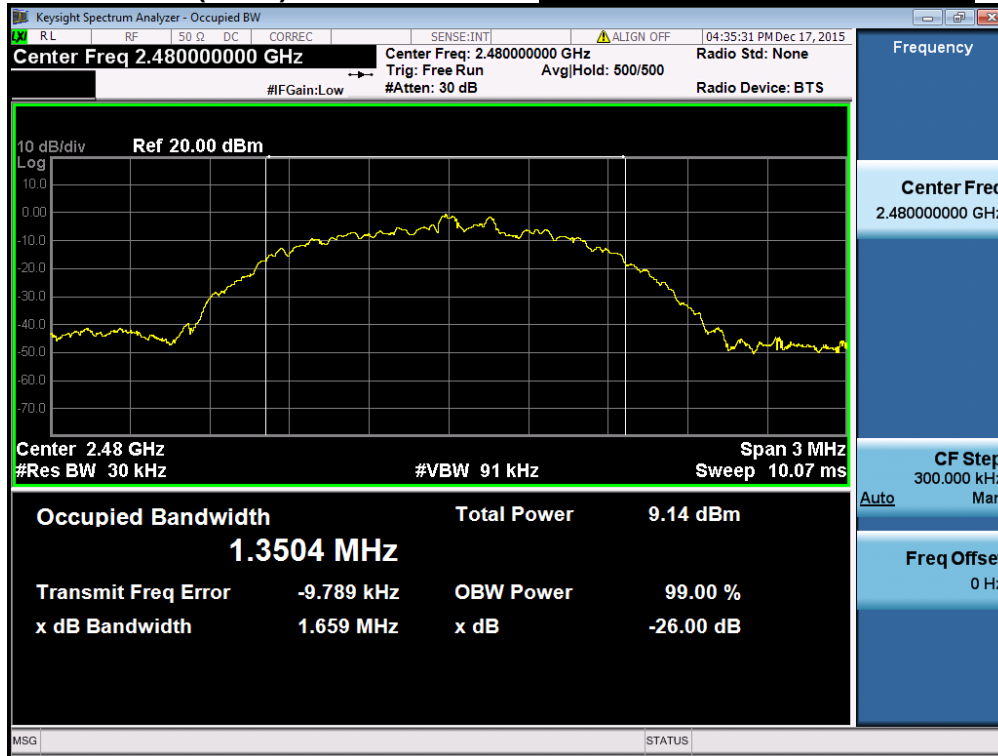

## APPENDIX I

### Test set up diagrams

#### ▪ Radiated Measurement

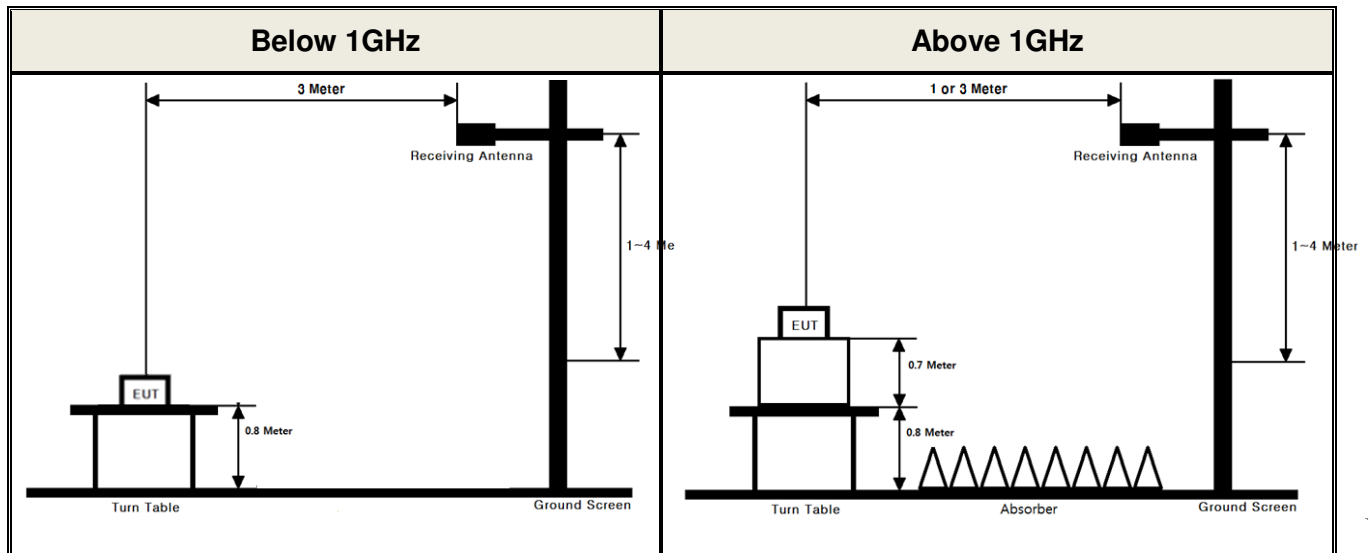

#### ▪ Conducted Measurement

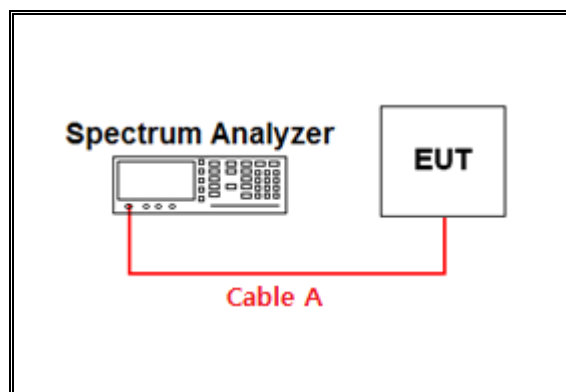

Path loss information

Frequency (GHz)	Path Loss (dB)	Frequency (GHz)	Path Loss (dB)
0.03	0.98	15	6.98
1	2.02	20	7.68
2402 & 2440 & 2480	2.49	25	8.89
5	4.02	-	-
10	4.89	-	-

Note 1 : The path loss from EUT to Spectrum analyzer were measured and used for test.

Path loss ( S/A's Correction factor) = Cable A + Power splitter

## APPENDIX II

### Unwanted Emissions (Radiated) Test Plot

GFSK & Lowest & Y axis & Hor

Detector Mode : PK

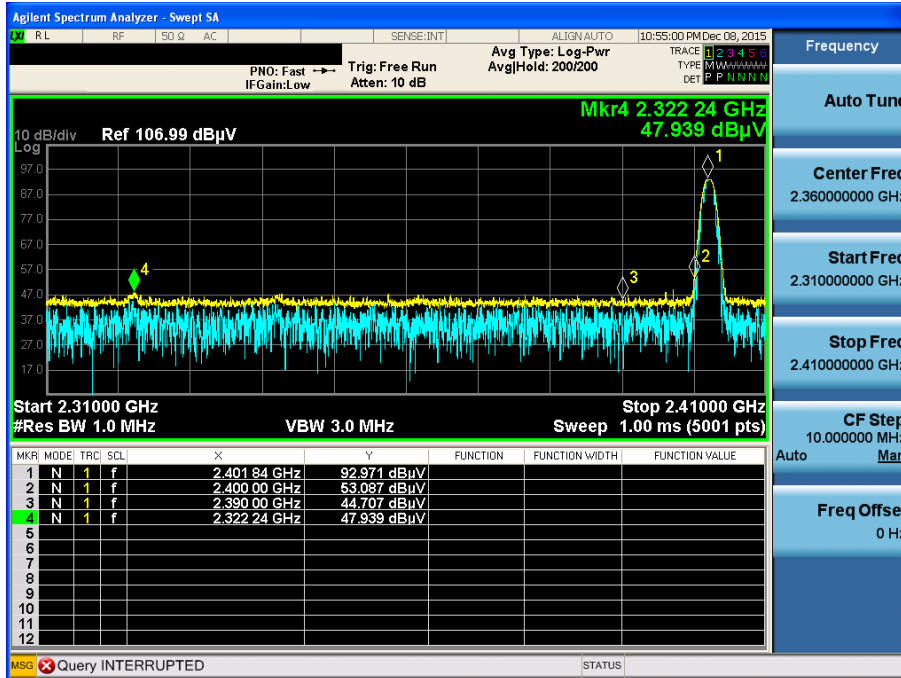

GFSK & Lowest & Y axis & Hor

Detector Mode : PK

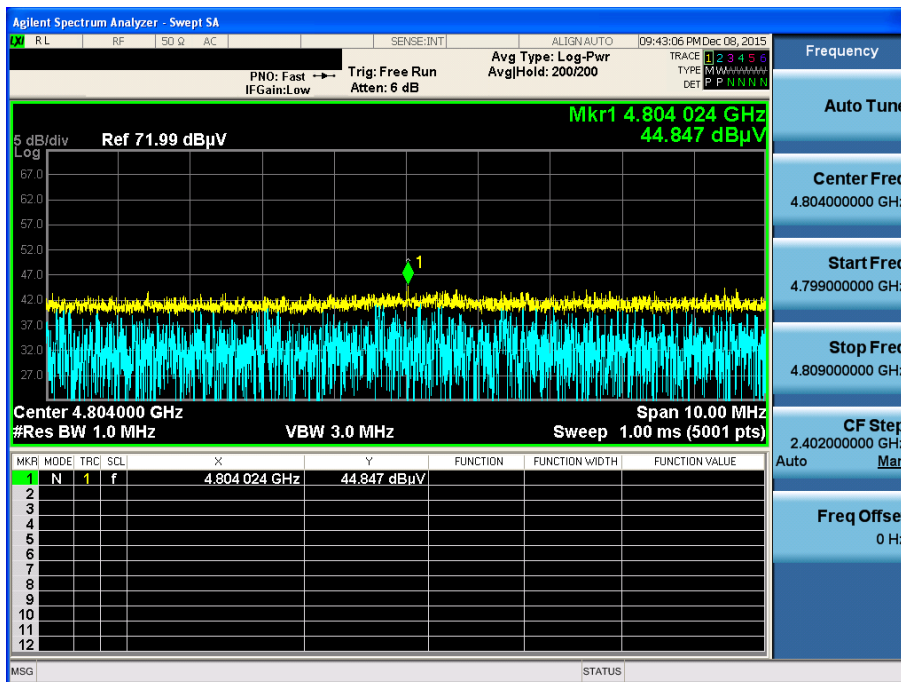



GFSK & Highest & Y axis & Hor

Detector Mode : PK

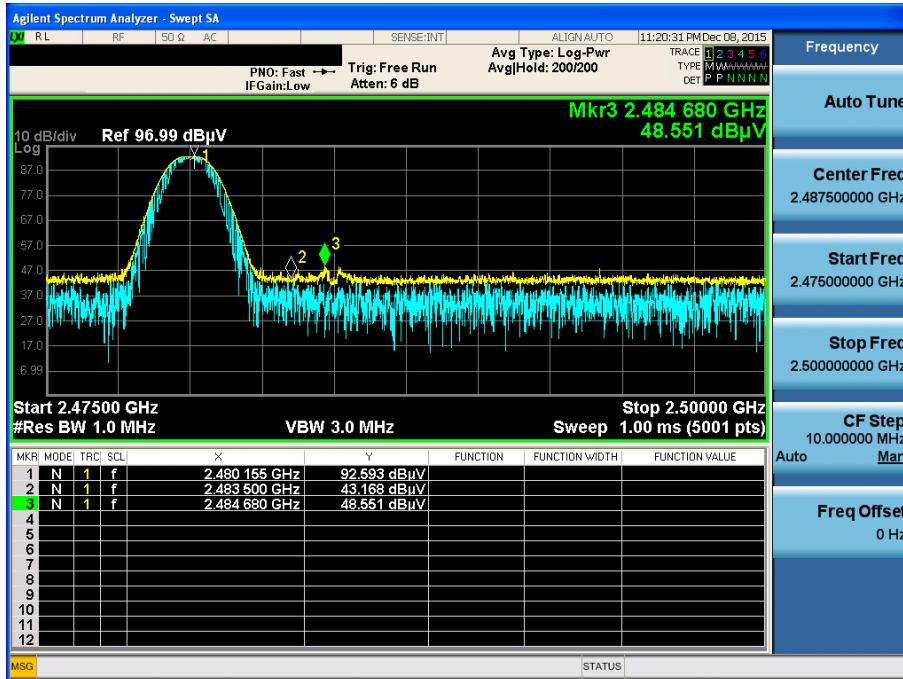

GFSK & Highest & Y axis & Hor

Detector Mode : PK

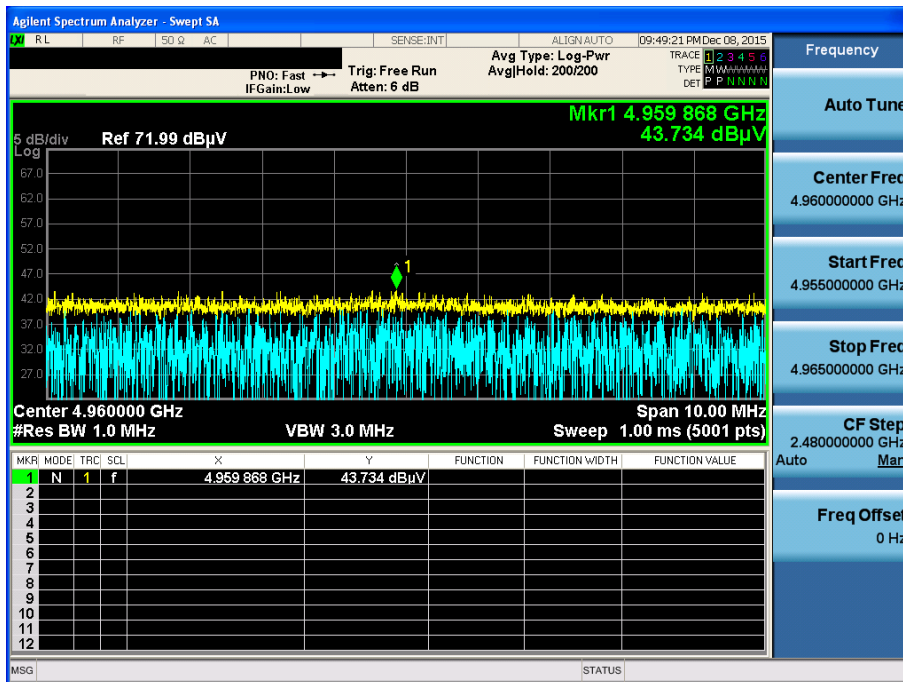

$\pi/4$ DQPSK & Lowest & Y axis & Hor

Detector Mode : PK

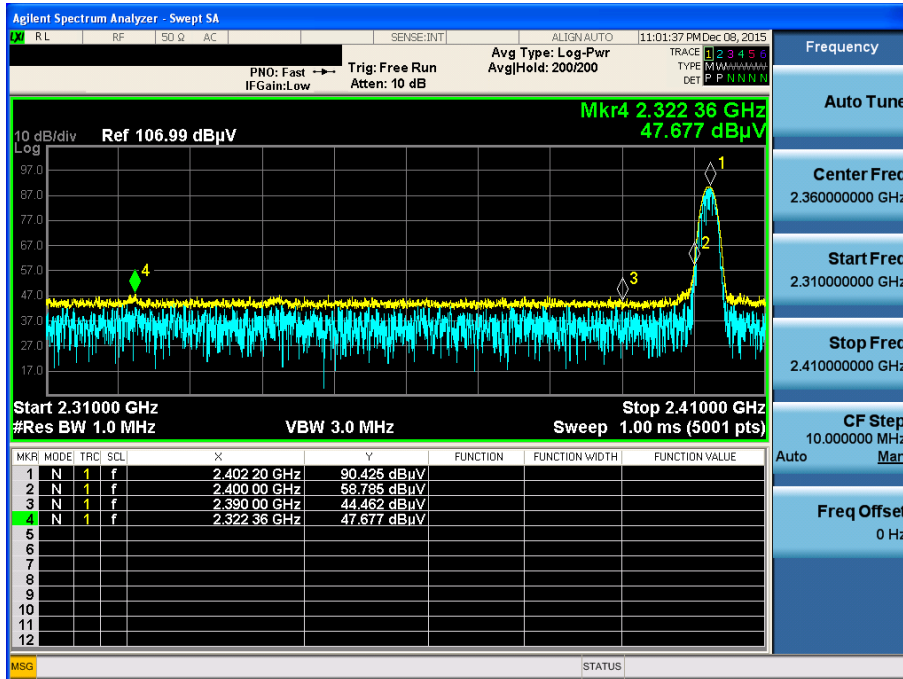

$\pi/4$ DQPSK Lowest & Y axis & Hor

Detector Mode : PK

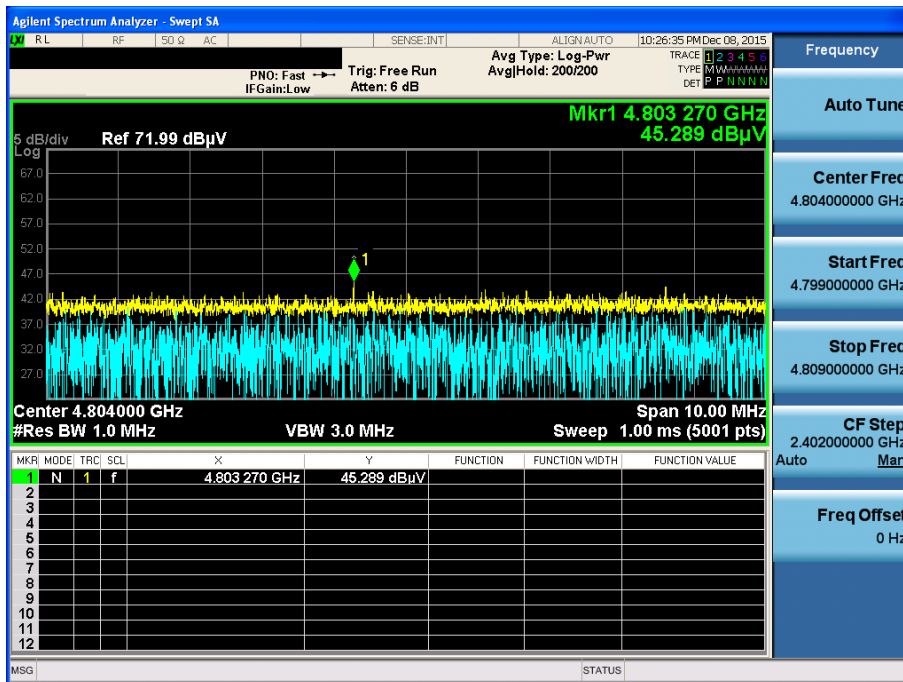



$\pi/4$ DQPSK & Highest & Y axis & Hor

Detector Mode : PK

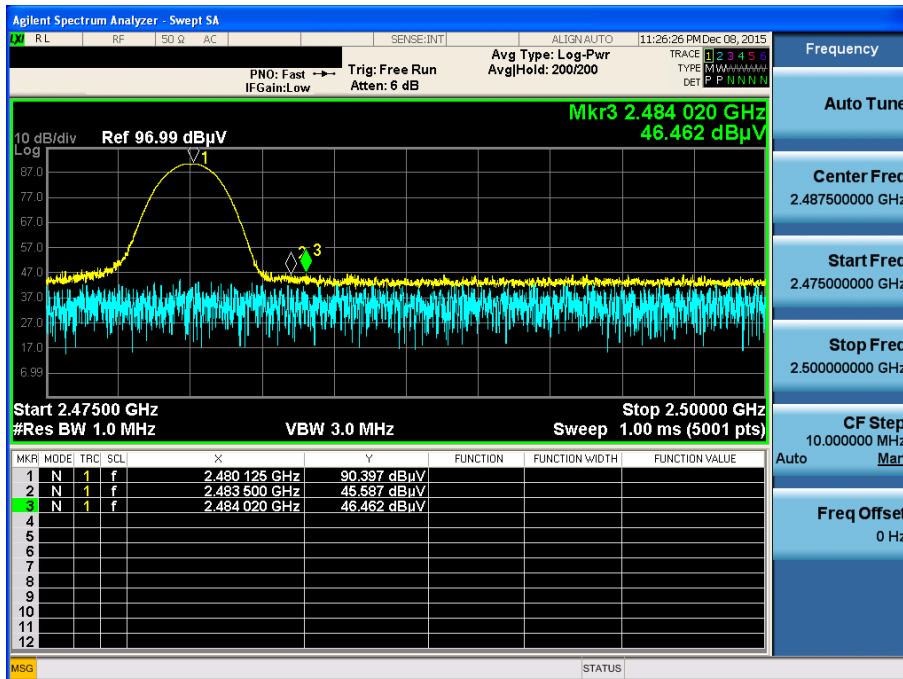

$\pi/4$ DQPSK & Highest & Y axis & Hor

Detector Mode : PK

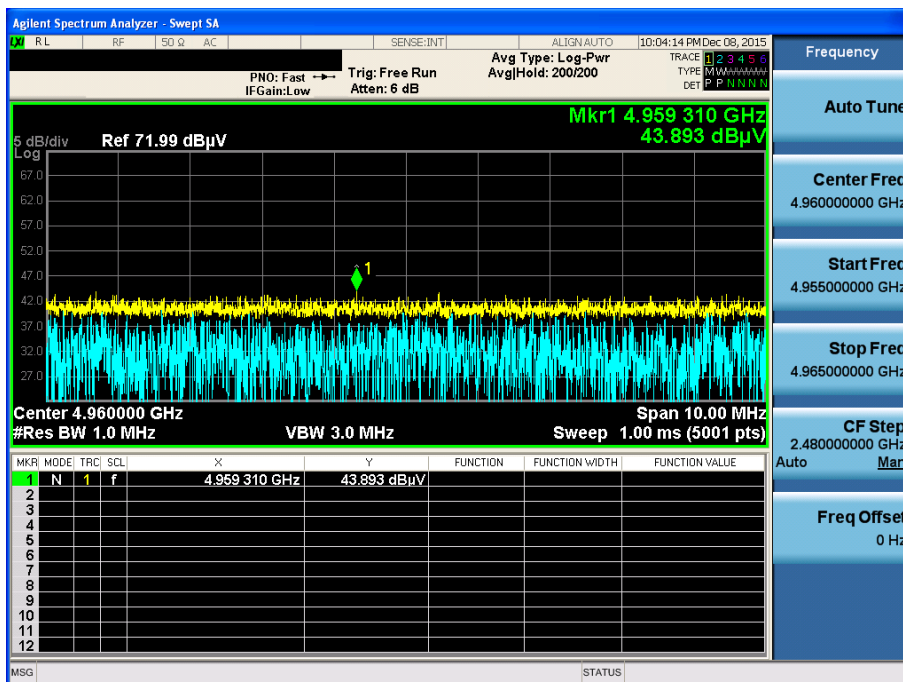

8DPSK & Lowest & Y axis & Hor

Detector Mode : PK

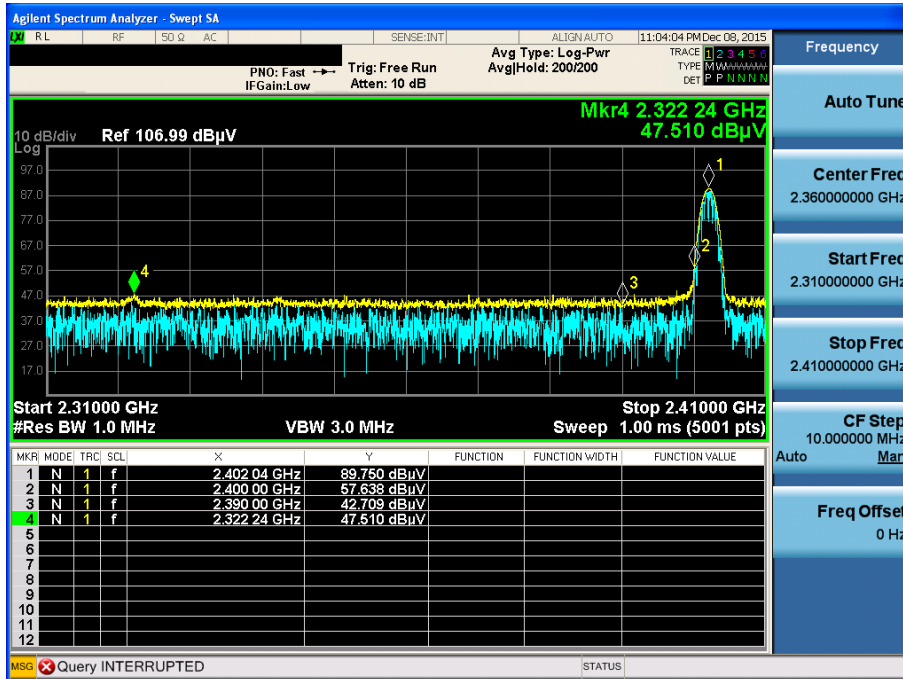

8DPSK & Lowest & Y axis & Hor

Detector Mode : PK

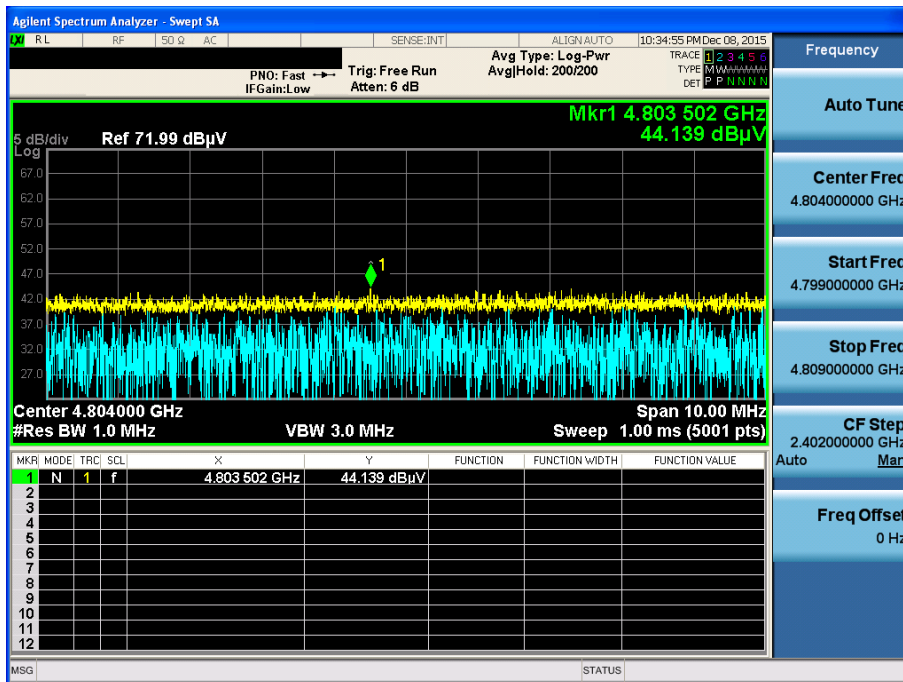



8DPSK & Highest & Y axis & Hor

Detector Mode : PK

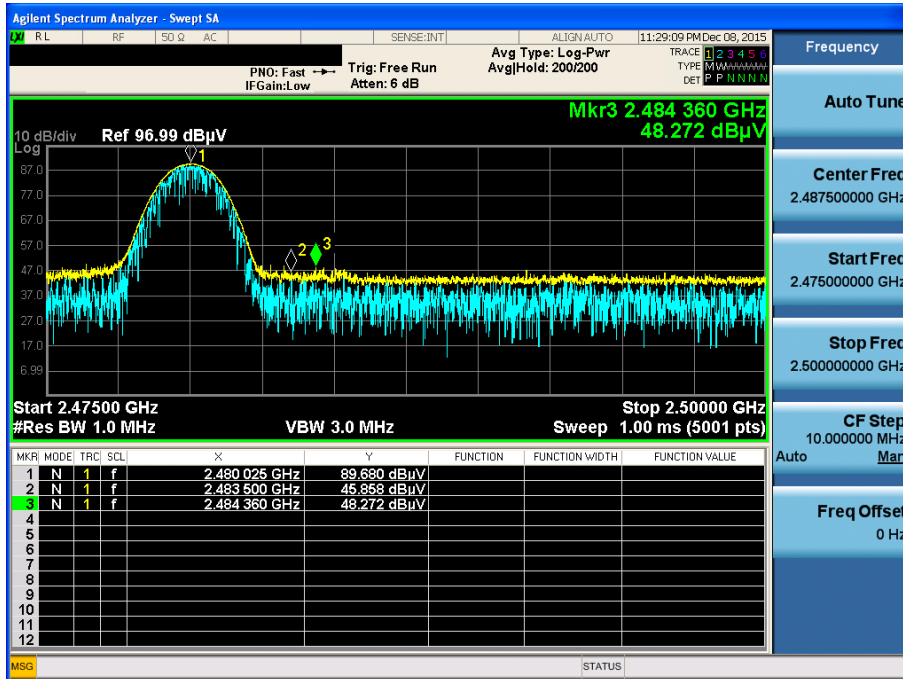

8DPSK & Highest & Y axis & Hor

Detector Mode : PK

