

## FCC 15.247& RSS-247 2.4 GHz Test Report

for

**LG Electronics Inc.**

**222, LG-roJinwi-myeon, Pyeongtaek-Si, Gyeonggi-Do,  
451-713, Korea**

**Product Name : Notebook Computer**  
**Model Name : (1)17Z95N (2)17ZD95N  
(3)17ZG95N (4)17ZB95N**  
**Brand : LG**  
**FCC ID : BEJNT-17Z95N**  
**IC : 2703H-17Z95N**

**Prepared by: : AUDIX Technology Corporation,  
EMC Department**



The test report is based on a single evaluation of one sample of the above-mentioned products. It does not imply an assessment of the whole production and does not permit the use of the test lab logo.

## TABLE OF CONTENTS

| Description  | Page      |
|--|-----------|
| TEST REPORT .....  | 4         |
| <b>1. REVISION RECORD OF TEST REPORT .....</b>           | <b>5</b>  |
| <b>2. SUMMARY OF TEST RESULTS .....</b>                  | <b>6</b>  |
| <b>3. GENERAL INFORMATION .....</b>                      | <b>7</b>  |
| 3.1. Description of Application .....                    | 7         |
| 3.2. Description of EUT .....                            | 8         |
| 3.3. Antenna Information .....                           | 9         |
| 3.4. EUT Specifications Assessed in Current Report ..... | 10        |
| 3.5. Description of Key Components .....                 | 11        |
| 3.6. Test Configuration .....                            | 14        |
| 3.7. Output Power Setting .....                          | 15        |
| 3.8. Tested Supporting System List .....                 | 15        |
| 3.9. Setup Configuration .....                           | 16        |
| 3.10. Operating Condition of EUT .....                   | 16        |
| 3.11. Description of Test Facility .....                 | 17        |
| 3.12. Measurement Uncertainty .....                      | 18        |
| <b>4. MEASUREMENT EQUIPMENT LIST .....</b>               | <b>19</b> |
| 4.1. Conducted Emission Measurement .....                | 19        |
| 4.2. Radiated Emission Measurement .....                 | 20        |
| 4.3. RF Conducted Measurement .....                      | 20        |
| <b>5. CONDUCTED EMISSION .....</b>                       | <b>21</b> |
| 5.1. Block Diagram of Test Setup .....                   | 21        |
| 5.2. Conducted Emission Limit .....                      | 21        |
| 5.3. Test Procedure .....                                | 21        |
| 5.4. Test Results .....                                  | 22        |
| <b>6. RADIATED EMISSION .....</b>                        | <b>23</b> |
| 6.1. Block Diagram of Test Setup .....                   | 23        |
| 6.2. Radiated Emission Limits .....                      | 25        |
| 6.3. Test Procedure .....                                | 26        |
| 6.4. Measurement Result Explanation .....                | 27        |
| 6.5. Test Results .....                                  | 27        |
| <b>7. 20dB/OCCUPIED BANDWIDTH .....</b>                  | <b>28</b> |
| 7.1. Block Diagram of Test Setup .....                   | 28        |
| 7.2. Specification Limits .....                          | 28        |
| 7.3. Test Procedure .....                                | 28        |
| 7.4. Test Results .....                                  | 28        |
| <b>8. CARRIER FREQUENCY SEPARATION .....</b>             | <b>29</b> |
| 8.1. Block Diagram of Test Setup .....                   | 29        |
| 8.2. Specification Limits .....                          | 29        |
| 8.3. Test Procedure .....                                | 29        |
| 8.4. Test Results .....                                  | 29        |
| <b>9. TIME OF OCCUPANCY .....</b>                        | <b>30</b> |
| 9.1. Block Diagram of Test Setup .....                   | 30        |



**Audix Technology Corp.**  
No. 53-11, Dingfu, Linkou, Dist.,  
New Taipei City 244, Taiwan

**Tel: +886 2 26099301**  
**Fax: +886 2 26099303**

---

|   |           |
|---|-----------|
| 9.2. Specification Limits.....                    | 30        |
| 9.3. Test Procedure.....                          | 30        |
| 9.4. Test Results .....                           | 30        |
| <b>10. NUMBER OF HOPPING CHANNELS .....</b>       | <b>31</b> |
| 10.1. Block Diagram of Test Setup .....           | 31        |
| 10.2. Specification Limits.....                   | 31        |
| 10.3. Test Procedure .....                        | 31        |
| 10.4. Test Results .....                          | 31        |
| <b>11. MAXIMUM PEAK OUTPUT POWER .....</b>        | <b>32</b> |
| 11.1. Block Diagram of Test Setup .....           | 32        |
| 11.2. Specification Limits.....                   | 32        |
| 11.3. Test Procedure .....                        | 32        |
| 11.4. Test Results .....                          | 32        |
| <b>12. EMISSION LIMITATIONS .....</b>             | <b>33</b> |
| 12.1. Block Diagram of Test Setup .....           | 33        |
| 12.2. Specification Limits.....                   | 33        |
| 12.3. Test Procedure .....                        | 33        |
| 12.4. Test Results .....                          | 33        |
| <b>13. DEVIATION TO TEST SPECIFICATIONS .....</b> | <b>34</b> |

APPENDIX A TEST DATA AND PLOTS  
APPENDIX B TESTPHOTOGRAPHS



**Audix Technology Corp.**  
No. 53-11, Dingfu, Linkou, Dist.,  
New Taipei City 244, Taiwan

**Tel: +886 2 26099301**  
**Fax: +886 2 26099303**

## TEST REPORT

Applicant : LG Electronics Inc.  
Manufacturer : LG Electronics Inc.  
Factory #1 : LG Electronics Nanjing New Technology Co., Ltd.  
Factory #2 : SEO HEUNG ELECTRONICS CO LTD  
EUT Description  
(1) Product : Notebook Computer  
(2) Model : (1)17Z95N (2)17ZD95N (3)17ZG95N (4)17ZB95N  
(3) Brand : LG  
(4) Power Supply: DC 19V, 2.53A

### Applicable Standards:

Title 47 CFR FCC Part 15 Subpart C  
RSS-Gen (Issue 5), April 2018  
RSS-247 (Issue 2), February 2017  
ANSI C63.10:2013

**Audix Technology Corp.** tested the equipment mentioned in accordance with the requirements set forth in the above standards. Test results indicate that the equipment tested is capable of demonstrating compliance with the requirements as documented within this report.

**Audix Technology Corp.** does not assume responsibility for any conclusions and generalizations drawn from the test results with regard to other specimens and samples.

Date of Report: 2020. 08. 24

Reviewed by:

(Tina Huang/Section Manager)

Approved by:

(Johnny Hsueh/Section Manager)



**Audix Technology Corp.**  
No. 53-11, Dingfu, Linkou, Dist.,  
New Taipei City 244, Taiwan

**Tel: +886 2 26099301**  
**Fax: +886 2 26099303**

---

## 1. REVISION RECORD OF TEST REPORT

| Edition No | Issued Date  | Revision Summary | Report Number |
|------------|--------------|------------------|---------------|
| 0          | 2020. 08. 24 | Original Report  | EM-F200359    |

## 2. SUMMARY OF TEST RESULTS

| Rule  |                              | Description  | Data Reused          | Results           |
|---|------------------------------|--|----------------------|-------------------|
| FCC   | IC                           |  |                      |                   |
| 15.207  | RSS-Gen §8.8                 | Conducted Emission                                   | No                   | <b>PASS</b>       |
| 15.247(d)/15.205  | RSS-Gen §8.9<br>RSS-247 §5.5 | Radiated Band Edge and Radiated Spurious Emission    | No                   | <b>PASS</b>       |
| 15.247(a)(1)  | RSS-247 §5.1(2)              | 20dB/Occupied Bandwidth                              | Yes                  | <b>PASS</b>       |
| 15.247(a)(1)  | RSS-247 §5.1(2)              | Carrier Frequency Separation                         | Yes                  | <b>PASS</b>       |
| 15.247(a)(1)(iii)   | RSS-247 §5.1(4)              | Time of Occupancy                                    | Yes                  | <b>PASS</b>       |
| 15.247(a)(1)(iii)   | RSS-247 §5.1(4)              | Number of Hopping Channels                           | Yes                  | <b>PASS</b>       |
| 15.247(b)(1)  | RSS-247 §5.1(2)              | Maximum Peak Output Power                            | SPOT CHECK<br>Note 2 | <b>PASS</b>       |
| 15.247(d)   | RSS-247 §5.5                 | Conducted Band Edges and Conducted Spurious Emission | Yes                  | <b>PASS</b>       |
| 15.203  | RSS-Gen §6.8                 | Antenna Requirement                                  | ---                  | <b>Compliance</b> |
| <p>Note: 1. The uncertainties value is not used in determining the result.<br/>           2. This device embedded with same radio transmitter with FCC ID: BEJNT-15Z90N, grant on 11/28 2019 and IC: 2703H-15Z90N approved on 12/04/2019. According to KDB 484596 D01, we did spot check for output power and all output power values keep identical thus we reuse all results.</p> |                              |  |                      |                   |

### 3. GENERAL INFORMATION

#### 3.1. Description of Application

|              |   |
|--------------|---|
| Applicant    | LG Electronics Inc.<br>222, LG-ro Jinwi-myeon, Pyeongtaek-Si, Gyeonggi-Do, 451-713,<br>Korea                                      |
| Manufacturer | LG Electronics Inc.<br>222, LG-ro Jinwi-myeon, Pyeongtaek-Si, Gyeonggi-Do, 451-713,<br>Korea                                      |
| Factory #1   | LG Electronics Nanjing New Technology Co., Ltd.<br>No.346, Yaoxin Road, Economic & Technical Development Zone,<br>Nanjing, China. |
| Factory #2   | SEO HEUNG ELECTRONICS CO LTD<br>55 Asan valley Seo-ro, Dunpo-myeon, Asan-si, Chungcheongnam-do,<br>31409 Korea                    |
| Product      | Notebook Computer   |
| Model        | (1)17Z95N (2)17ZD95N (3)17ZG95N (4)17ZB95N<br>The difference between all models is different in the sales customers.              |
| Brand        | LG  |

### 3.2. Description of EUT

|                        |   |                                  |          |
|------------------------|---|----------------------------------|----------|
| Test Model             | 17Z95N  |                                  |          |
| Serial Number          | N/A   |                                  |          |
| Power Rating           | DC 19V, 2.53A   |                                  |          |
| Software Version       | XY (X, Y can be 0 to 9 for different SW version not influence RF parameter)   |                                  |          |
| RF Features            | WLAN: 802.11 a/b/g/n/ac/ax<br>Bluetooth: BT and BLE (BT 5.0)  |                                  |          |
| Transmit Type          | 2.4 GHz   |                                  |          |
|                        | 802.11b   |                                  | 1T1R     |
|                        | 802.11g   |                                  | 1T1R     |
|                        | 802.11n-HT20  |                                  | 2T2R     |
|                        | 802.11n-HT40  |                                  | 2T2R     |
|                        | 802.11ax-HE20   |                                  | 2T2R     |
|                        | 802.11ax-HE40   |                                  | 2T2R     |
|                        | BT/BLE  |                                  | 1T1R     |
|                        | UNII Bands  |                                  |          |
|                        | 802.11a   |                                  | 1T1R     |
|                        | 802.11n-HT20/802.11ac-VHT20/802.11ax-HE20   |                                  | 2T2R     |
|                        | 802.11n-HT40/802.11ac-VHT40/802.11ax-HE40   |                                  | 2T2R     |
|                        | 802.11ac-VHT80/802.11ax-HE80  |                                  | 2T2R     |
|                        | 802.11ac-VHT160/802.11ax-HE160  |                                  | 2T2R     |
|                        | The MIMO is uncorrelated and supported SDM mode only.   |                                  |          |
| Sample Status          | Mass production   |                                  |          |
| Test Sample            | Sample No.  | Test Item                        | Firmware |
|                        | -02   | AC Conduction, RSE, Output Power | N/A      |
|                        | -04   | AC Conduction, RSE, Output Power | N/A      |
| Date of Receipt        | 2020. 07. 24  |                                  |          |
| Date of Test           | 2020. 08. 14 ~ 21   |                                  |          |
| Interface Ports of EUT | <ul style="list-style-type: none"> <li>• One Micro SD Card Slot</li> <li>• One Earphone Port</li> <li>• Three USB 3.0 Ports</li> <li>• One USB Type C Port</li> <li>• One HDMI Port</li> <li>• One DC Input Port</li> </ul> |                                  |          |
| Accessories Supplied   | <ul style="list-style-type: none"> <li>• AC Adapter</li> <li>• LAN Gender</li> </ul>  |                                  |          |



### 3.3. Antenna Information

| No. | Antenna Part Number        | Manufacture      | Antenna Type | Frequency (MHz) | Max Gain (dBi) |
|-----|----------------------------|------------------|--------------|-----------------|----------------|
| 1.  | WA-P-LBLB-04-068<br>(Main) | INPAQ            | Mono-Pole    | 2400~2500       | 4.12           |
|     |                            |                  |              | 5100-5250       | 3.52           |
|     |                            |                  |              | 5250-5350       | 3.36           |
|     |                            |                  |              | 5350-5750       | 4.92           |
|     |                            |                  |              | 5750~5850       | 3.74           |
|     | WA-P-LBLB-04-068<br>(AUX)  | INPAQ            | Mono-Pole    | 2400~2500       | 4.52           |
|     |                            |                  |              | 5100-5250       | 2.96           |
|     |                            |                  |              | 5250-5350       | 2.37           |
|     |                            |                  |              | 5350-5750       | 4.11           |
|     |                            |                  |              | 5750~5850       | 3.13           |
| 2.  | L1LRF001-CS-H<br>(Main)    | LUXSHARE-<br>ICT | Mono-Pole    | 2400~2500       | 4.80           |
|     |                            |                  |              | 5150-5250       | 4.30           |
|     |                            |                  |              | 5250-5350       | 4.30           |
|     |                            |                  |              | 5350-5725       | 4.50           |
|     |                            |                  |              | 5725~5850       | 4.50           |
|     | L1LRF001-CS-H (AUX)        | LUXSHARE-<br>ICT | Mono-Pole    | 2400~2500       | 4.20           |
|     |                            |                  |              | 5150-5250       | 3.20           |
|     |                            |                  |              | 5250-5350       | 3.20           |
|     |                            |                  |              | 5350-5725       | 4.30           |
|     |                            |                  |              | 5725~5850       | 4.20           |

### 3.4. EUT Specifications Assessed in Current Report

| Mode      | Fundamental Range (MHz) | Channel Number | Modulation                         | Data Rate (Mbps) |
|-----------|-------------------------|----------------|------------------------------------|------------------|
| Bluetooth | 2402-2480               | 79             | FHSS (GFSK, $\pi/4$ DQPSK, 8-DPSK) | 1/2/3            |

| Channel List   |                 |                |                 |                |                 |                |                 |
|----------------|-----------------|----------------|-----------------|----------------|-----------------|----------------|-----------------|
| Channel Number | Frequency (MHz) | Channel Number | Frequency (MHz) | Channel Number | Frequency (MHz) | Channel Number | Frequency (MHz) |
| 00             | 2402            | 20             | 2422            | 40             | 2442            | 60             | 2462            |
| 01             | 2403            | 21             | 2423            | 41             | 2443            | 61             | 2463            |
| 02             | 2404            | 22             | 2424            | 42             | 2444            | 62             | 2464            |
| 03             | 2405            | 23             | 2425            | 43             | 2445            | 63             | 2465            |
| 04             | 2406            | 24             | 2426            | 44             | 2446            | 64             | 2466            |
| 05             | 2407            | 25             | 2427            | 45             | 2447            | 65             | 2467            |
| 06             | 2408            | 26             | 2428            | 46             | 2448            | 66             | 2468            |
| 07             | 2409            | 27             | 2429            | 47             | 2449            | 67             | 2469            |
| 08             | 2410            | 28             | 2430            | 48             | 2450            | 68             | 2470            |
| 09             | 2411            | 29             | 2431            | 49             | 2451            | 69             | 2471            |
| 10             | 2412            | 30             | 2432            | 50             | 2452            | 70             | 2472            |
| 11             | 2413            | 31             | 2433            | 51             | 2453            | 71             | 2473            |
| 12             | 2414            | 32             | 2434            | 52             | 2454            | 72             | 2474            |
| 13             | 2415            | 33             | 2435            | 53             | 2455            | 73             | 2475            |
| 14             | 2416            | 34             | 2436            | 54             | 2456            | 74             | 2476            |
| 15             | 2417            | 35             | 2437            | 55             | 2457            | 75             | 2477            |
| 16             | 2418            | 36             | 2438            | 56             | 2458            | 76             | 2478            |
| 17             | 2419            | 37             | 2439            | 57             | 2459            | 77             | 2479            |
| 18             | 2420            | 38             | 2440            | 58             | 2460            | 78             | 2480            |
| 19             | 2421            | 39             | 2441            | 59             | 2461            |                |                 |

### 3.5. Description of Key Components

#### 3.5.1. For the All Component Lists

| Item                          | Supplier             | Model / Type        | Character  |
|-------------------------------|----------------------|---------------------|--|
| System                        | Microsoft            | Win10 Home          | ---  |
|                               |                      | Win10 Pro           | ---  |
| Main Board                    | LG                   | 1XZ95N MAIN B/D PCB | Manufacturer:<br>#1 Hannstar Board Tech (Jiang Yin) Corp., Ltd.<br>#2 Elec & Eltek Company (MCO) Limited.              |
| WLAN SUB Board                | LG                   | 17Z95N WLAN SUB B/D | Manufacturer:<br>#1 Hannstar Board Tech (Jiang Yin) Corp., Ltd.<br>#2 Elec & Eltek Company (MCO) Limited.              |
| CPU<br>(Socket: FCBGA1526)    | Intel                | i5-1135G7           | 2.4 GHz  |
|                               | Intel                | i7-1165G7           | 2.8GHz   |
|                               | Intel                | i3-1115G4           | 3.0GHz,  |
| 17" LCD Panel                 | LG Display           | LP170WQ1(SP)(A1)    | Resolution: 2560 x 1600, 60Hz<br>WQXGA IPS<br>(Normal Non touch)   |
| Storage (SSD)<br>(Max. 2 pcs) | SK hynix             | HFS256GD9TNG-L2A0A  | 256GB (M.2)  |
|                               |                      | HFS512GD9TNG-L2A0A  | 512GB (M.2)  |
|                               |                      | HFS001TD9TNG-L2A0A  | 1TB (M.2)  |
|                               | Samsung              | MZ-VLB256B          | 256GB (M.2)  |
|                               |                      | MZ-VLB512B          | 512GB (M.2)  |
|                               |                      | MZ-VLB1T0B          | 1TB (M.2)  |
|                               |                      | MZ-NLN128C          | 128GB (M.2)  |
| Memory (RAM)                  | Samsung              | ---                 | 16GB LPDDR4x (On Board)  |
|                               | Samsung              | ---                 | 8GB LPDDR4x (On Board)   |
|                               | SK Hynix             | ---                 | 16GB LPDDR4x (On Board)  |
|                               | SK Hynix             | ---                 | 8GB LPDDR4x (On Board)   |
| Battery Pack                  | LG                   | LBV7227E            | DC 7.74V, 80Wh, Typ 10336mAh   |
| WLAN Combo Card               | Intel                | AX201D2W            | WLAN and BT, 2x2 PCIe M.2 1216<br>SD adapter Card<br>FCC ID: PD9AX201D2<br>IC: 1000M-AX201D2<br>NCC ID: CCAH18LP3410T5 |
| WLAN Combo Antenna            | LG<br>(INPAQ)        | WA-P-LBLB-04-068    | PCB, Mono-pole Type<br>Main: Black, Aux: Gray  |
|                               | LG<br>(LUXSHARE-ICT) | L1LRF001-CS-H       | PCB, Mono-pole Type<br>Main: Black, Aux: Gray  |

| Item                          | Supplier  | Model / Type         | Character  |
|-------------------------------|---|----------------------|--|
| Keyboard                      | TIC   | KT01-19A6            | P/N KT01-19A6BS03KRRA000<br>(White KBD)                |
|                               |   | KT01-19A6            | P/N KT01-19A6AS03USRA000<br>(Black KBD)                |
|                               | LITE ON   | SN3890BL             | P/N SG-90980-XUA (White KBD)                           |
|                               |   | SN3890BL             | P/N: SG-90970-XUA (Black KBD)                          |
| Web Camera                    | Chicony   | CKFIH2821005290LH    | With two microphones                                   |
|                               |   | CKFIH28-121005290LH  | With One microphone                                    |
|                               | Luxvisions  | 7BF109N2DC           | With two microphones                                   |
|                               |   | 7BF109N2C            | With One microphone                                    |
| LAN Gender<br>(Type C to LAN) | SUZHOU MEC<br>ELECTRONICS   | 80-5946-111          | (White) 10/100Megabit Ethernet                         |
|                               |   | 80-5946-101          | (Black) 10/100 Megabit Ethernet                        |
|                               | Type C to LAN: Shielded, Undetached, 0.12m  |                      |  |
|                               | ARIN TECH CO.<br>LTD  | GD-08MF-36-WH-LP10   | (White) 10/100Megabit Ethernet                         |
|                               |   | GD-08MF-36-BK-LP11   | (Black) 10/100 Megabit Ethernet                        |
|                               | Type C to LAN: Shielded, Undetached, 0.12m  |                      |  |
| AC Adapter (48W)              | LG (HONOR)  | ADS-48MS-19-2 19048E | I/P: AC 100-240V, 50-60Hz, 1.5A,<br>O/P: DC 19V, 2.53A |
|                               | DC Power Cord: Non-Shielded, Undetached, 1.5m<br>AC Power Cord: Non-Shielded, Detached, 1.0m (2C) (For Other Countries)<br>AC Power Cord: Non-Shielded, Detached, 1.55m (2C) (For US, Canada, Mexico) |                      |  |

Remark: For more detailed features description, please refer to the manufacturer's specifications or the user manual.

3.5.2. The EUT collocates with following worst components, which are used to establish a basic configuration of system during test:

| SKU                           |  | #1 | #2 |
|-------------------------------|--|----|----|
| System                        | Microsoft, Win10 Home                                  | V  | V  |
| Main Board                    | LG, 1XZ95N MAIN B/D PCB                                | V  | V  |
| SUB Board                     | LG, 17Z95N WLAN SUB B/D                                | V  | V  |
| CPU                           | Intel, i7-1165G7                                       | V  |    |
|                               | Intel, i5-1135G7                                       |    | V  |
| 17" LCD Panel                 | LG Display, LP170WQ1(SP)(A1)                           | V  | V  |
| Storage (SSD)                 | SK hynix, 256GB *1                                     | V  |    |
|                               | SK hynix, 512GB *1                                     |    | V  |
|                               | SK hynix, 1TB *1                                       | V  |    |
|                               | Samsung, 128GB   |    | V  |
| Memory (RAM)                  | Samsung, 16GB *4                                       | V  |    |
|                               | Samsung, 8GB *4  |    | V  |
| Battery Pack                  | LG, LBV7227E   | V  | V  |
| WLAN Combo Card               | Intel, AX201D2W  | V  | V  |
| WLAN Combo Antenna            | LG (INPAQ), WA-P-LBLB-04-068                           | V  |    |
|                               | LG (LUXSHARE-ICT), L1LRF001-CS-H                       |    | V  |
| Keyboard                      | LITE ON, SN3890BL<br>P/N SG-90970-XUA (Black KBD)      | V  |    |
|                               | TIC, KT01-19A6<br>P/N KT01-19A6BS03KRRA000 (White KBD) |    | V  |
|                               |  |    |    |
| Web Camera                    | Chicony, CKFIH2821005290LH                             | V  |    |
|                               | Luxvisions , 7BF109N2DC                                |    | V  |
| LAN Gender<br>(Type C to LAN) | ARIN TECH CO. LTD, GD-08MF-36-BK-LP11 (Black)          | V  |    |
|                               | ARIN TECH CO. LTD, GD-08MF-36-WH-LP10 (White)          |    | V  |
| AC Adapter                    | LG (HONOR), ADS-48MS-19-2 19048E                       | V  | V  |

### 3.6. Test Configuration

| Mode | Duty Cycle (x) | T (ms) | Duty Cycle Correction Factor (dB) |
|------|----------------|--------|-----------------------------------|
| BT   | N/A            | 2.890  | N/A                               |

| AC Conduction |  |
|---------------|--|
| SKU #1        | Normal operation (with INPAQ Antenna)        |
| SKU #2        | Normal operation (with LUXSHARE-ICT Antenna) |

| Item                               |   | Modulation                                   | Data Rate | Test Channel |          |
|------------------------------------|---|--|-----------|--------------|----------|
| Radiated Test Case                 | SKU #1  | Radiated Band Edge <sup>Note 1 &amp; 2</sup> | GFSK      | 1Mbps        | 00/78    |
|                                    |   |  | 8-DPSK    | 3Mbps        | 00/78    |
|                                    |   | Radiated Spurious Emission <sup>Note 1</sup> | GFSK      | 1Mbps        | 00/39/78 |
|                                    | SKU #2  | Radiated Band Edge <sup>Note 1 &amp; 2</sup> | GFSK      | 1Mbps        | 00/78    |
|                                    |   |  | 8-DPSK    | 3Mbps        | 00/78    |
|                                    |   | Radiated Spurious Emission <sup>Note 1</sup> | GFSK      | 1Mbps        | 00/39/78 |
| Conducted Test Case                | 20dB/Occupied Bandwidth<br>(Data Reused)      | GFSK   | 1Mbps     | 00/39/78     |          |
|                                    |   | 8-DPSK                                       | 3Mbps     | 00/39/78     |          |
|                                    | Carrier Frequency Separation<br>(Data Reused) | GFSK   | 1Mbps     | 00/39/78     |          |
|                                    |   | 8-DPSK                                       | 3Mbps     | 00/39/78     |          |
|                                    | Time of Occupancy<br>(Data Reused)            | GFSK   | 1Mbps     | 00/39/78     |          |
|                                    |   | 8-DPSK                                       | 3Mbps     | 00/39/78     |          |
|                                    | Number of Hopping Channels<br>(Data Reused)   | GFSK   | 1Mbps     | 39           |          |
|                                    |   | 8-DPSK                                       | 3Mbps     | 39           |          |
|                                    | Maximum Peak Output Power<br>(SPOT Check)     | GFSK   | 1Mbps     | 00/39/78     |          |
|                                    |   | 8-DPSK                                       | 3Mbps     | 00/39/78     |          |
|                                    | Band Edges<br>(Data Reused)                   | GFSK   | 1Mbps     | 00/78        |          |
|                                    |   | 8-DPSK                                       | 3Mbps     | 00/78        |          |
| Spurious Emission<br>(Data Reused) | GFSK  | 1Mbps  | 00/39/78  |              |          |
|                                    | 8-DPSK  | 3Mbps  | 00/39/78  |              |          |

Note 1:  Mobile Device

Portable Device, and 3 axis were assessed. The worst scenario for Radiated Spurious Emission as follow:  Lie  Side  Stand

Note 2: We performed testing of the highest and lowest data rate.

### 3.7. Output Power Setting

| Centre Frequency (MHz) | Power Setting |        |
|------------------------|---------------|--------|
|                        | GFSK          | 8-DPSK |
| 2402                   | 12            | 12     |
| 2441                   | 12            | 12     |
| 2480                   | 12            | 12     |

### 3.8. Tested Supporting System List

#### 3.8.1. Support Peripheral Unit

| No.                   | Product     | Brand  | Model No.      | Serial No.    | Approval                         |
|-----------------------|-------------|--------|----------------|---------------|----------------------------------|
| 1.                    | LCD Monitor | LG     | 22LK330-DB     | N/A           | N/A                              |
| 2.                    | USB Mouse   | LENOVO | 45J4886        | N/A           | FCC By DoC                       |
| 3.                    | Earphone    | APPLE  | N/A            | N/A           | N/A                              |
| 4.                    | SD Card     | ADATA  | MicroSDHC Card | N/A           | N/A                              |
| <b>Partner System</b> |             |        |                |               |                                  |
| 5.                    | AP Server   | D-Link | DIR-868L       | R3WE1D7002319 | FCC ID: KA2IR868LA1              |
|                       |             |        |                |               | Contains FCC ID: RRK2012060056-1 |
| 6                     | Notebook PC | Lenovo | TP00034A       | 895097        | FCC By DoC                       |

#### 3.8.2. Cable Lists

| No. | Cable Description Of The Above Support Units   |
|-----|--|
| 1.  | HDMI Cable: Shielded, Detachable, 1.8m<br>AC Power Cord: Unshielded, Detachable, 1.8m                    |
| 2.  | USB Cable: Unshielded, Undetachable, 1.8m  |
| 3.  | Earphone Cable: Unshielded, Undetachable, 0.9m   |
| 4.  | N/A  |
| 5.  | AC adapter: M/N:WA-30B12, Cable: Unshielded, Detachable, 1.2m<br>LAN cable: Unshielded, Detachable, 3.0m |
| 6.  | LAN cable: Unshielded, Detachable, 1.8m  |

### 3.9. Setup Configuration

#### 3.9.1. EUT Configuration for Power Line & Radiated Emission

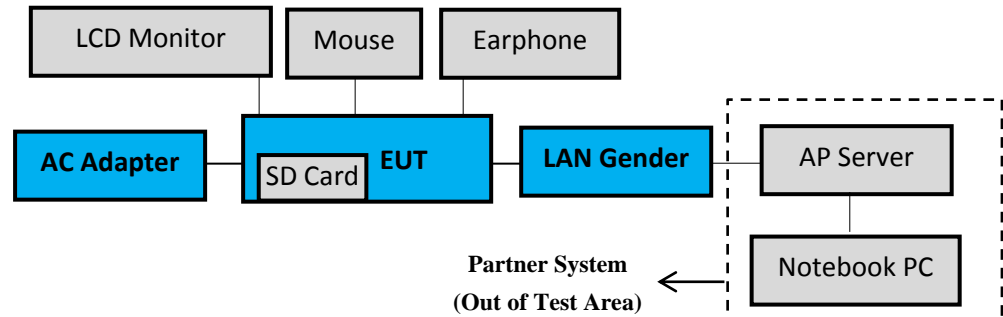

#### 3.9.2. EUT Configuration for RF Conducted Test Items



### 3.10. Operating Condition of EUT

Test program “DRTU” is used for enabling EUT BT function under continues transmitting and choosing data rate/ channel.



### 3.11. Description of Test Facility

|                   |   |
|-------------------|---|
| Name of Test Firm | Audix Technology Corporation / EMC Department<br>No. 53-11, Dingfu, Linkou Dist., New Taipei City 244, Taiwan<br>Tel: +886-2-26092133<br>Fax: +886-2-26099303<br>Website : www.audixtech.com<br>Contact e-mail: attemc_report@audixtech.com |
| Accreditations    | The laboratory is accredited by following organizations under ISO/IEC 17025:2017<br>(1) NVLAP(USA)<br>NVLAP Lab Code 200077-0<br>(2) TAF(Taiwan)<br>No. 1724  |
| Test Facilities   | FCC OET Designation Number under APEC MRA by NCC is :<br>TW1724<br>ISED CAB Identifier Number under APEC TEL MRA by NCC is<br>TW1724<br>(1) No.8 Shielded Room<br>(2) No.1 3m Semi Anechoic Chamber<br>(3) Fully Anechoic Chamber           |

### 3.12.Measurement Uncertainty

| Test Items/Facilities               |                                     | Frequency Range               | Uncertainty                    |        |
|-------------------------------------|-------------------------------------|-------------------------------|--------------------------------|--------|
| Conduction Test                     |                                     | 9kHz-150kHz                   | ±3.7dB                         |        |
|                                     |                                     | 150kHz-30MHz                  | ±3.5dB                         |        |
| Radiation Test                      | <input checked="" type="checkbox"/> | No.1 3m Semi Anechoic Chamber | 30MHz-200MHz, 3m, Horizontal   | ±4.1dB |
|                                     |                                     |                               | 200MHz-1000MHz, 3m, Horizontal | ±3.9dB |
|                                     |                                     |                               | 30MHz-200MHz, 3m, Vertical     | ±4.2dB |
|                                     |                                     |                               | 200MHz-1000MHz, 3m, Vertical   | ±4.1dB |
|                                     |                                     |                               | 1GHz-6GHz, 3m                  | ±4.2dB |
|                                     |                                     |                               | 6GHz-18GHz, 3m                 | ±4.6dB |
|                                     | <input type="checkbox"/>            | No.3 3m Semi Anechoic Chamber | 30MHz-200MHz, 3m, Horizontal   | ±3.9dB |
|                                     |                                     |                               | 200MHz-1000MHz, 3m, Horizontal | ±3.9dB |
|                                     |                                     |                               | 30MHz-200MHz, 3m, Vertical     | ±4.4dB |
|                                     |                                     |                               | 200MHz-1000MHz, 3m, Vertical   | ±4.1dB |
|                                     | <input type="checkbox"/>            | No.4 3m Semi Anechoic Chamber | 30MHz-200MHz, 3m, Horizontal   | ±4.3dB |
|                                     |                                     |                               | 200MHz-1000MHz, 3m, Horizontal | ±4.0dB |
|                                     |                                     |                               | 30MHz-200MHz, 3m, Vertical     | ±4.3dB |
|                                     |                                     |                               | 200MHz-1000MHz, 3m, Vertical   | ±4.4dB |
|                                     |                                     |                               | 1GHz-6GHz, 3m                  | ±4.5dB |
|                                     |                                     |                               | 6GHz-18GHz, 3m                 | ±4.6dB |
|                                     | <input type="checkbox"/>            | No.5 3m Semi Anechoic Chamber | 30MHz-200MHz, 3m, Horizontal   | ±4.0dB |
|                                     |                                     |                               | 200MHz-1000MHz, 3m, Horizontal | ±3.9dB |
|                                     |                                     |                               | 30MHz-200MHz, 3m, Vertical     | ±4.2dB |
|                                     |                                     |                               | 200MHz-1000MHz, 3m, Vertical   | ±4.3dB |
| 1GHz-6GHz, 3m                       |                                     |                               | ±4.3dB                         |        |
| 6GHz-18GHz, 3m                      |                                     |                               | ±4.7dB                         |        |
| <input checked="" type="checkbox"/> | Fully Anechoic Chamber              | 30MHz~1000MHz                 | ±4.7dB                         |        |
|                                     |                                     | 1GHz~18GHz                    | ±5.3dB                         |        |

Remark : Uncertainty =  $ku_c(y)$

| Test Item                      | Uncertainty |
|--------------------------------|-------------|
| 20dB Bandwidth                 | ±0.2kHz     |
| 99% Occupied Bandwidth         | ±0.38%      |
| Carrier Frequency Separation   | ±0.2kHz     |
| Time of Occupancy              | ±0.03sec    |
| Maximum peak Output power      | ± 0.52dB    |
| Conducted Emission Limitations | ± 0.13dB    |

## 4. MEASUREMENT EQUIPMENT LIST

### 4.1. Conducted Emission Measurement

| Item | Type                       | Manufacturer | Model No. | Serial No. | Cal. Date    | Cal. Interval |
|------|----------------------------|--------------|-----------|------------|--------------|---------------|
| 1.   | Test Receiver              | R&S          | ESR3      | 101774     | 2020. 02. 04 | 1 Year        |
| 2.   | A.M.N.                     | R&S          | ENV4200   | 100169     | 2019. 11. 13 | 1 Year        |
| 3.   | L.I.S.N.                   | Kyoritsu     | KNW-407   | 8-855-9    | 2019. 12. 10 | 1 Year        |
| 4.   | Pulse Limiter              | R&S          | ESH3-Z2   | 100354     | 2020. 01. 05 | 1 Year        |
| 5.   | Digital Thermo-Hygro Meter | iMax         | HTC-1     | No.8 S/R   | 2020 04. 17  | 1 Year        |
| 6.   | Coaxial Cable              | Yeida        | RG/58AU   | CE-08      | 2019. 09. 20 | 1 Year        |
| 7.   | Test Software              | Audix        | e3        | V6.120619c | N.C.R.       | N.C.R.        |

## 4.2. Radiated Emission Measurement

| Item | Type                          | Manufacturer     | Model No.                        | Serial No.                | Cal. Date    | Cal. Interval |
|------|-------------------------------|------------------|----------------------------------|---------------------------|--------------|---------------|
| 1.   | Spectrum Analyzer             | Agilent          | N9030A-526                       | MY53400071                | 2020. 01. 16 | 1 Year        |
| 2.   | Spectrum Analyzer             | Keysight         | N9010B-544                       | MY55460198                | 2020. 04. 29 | 1 Year        |
| 3.   | Test Receiver                 | R&S              | ESCS30                           | 100338                    | 2020. 06. 10 | 1 Year        |
| 4.   | Amplifier                     | HP               | 8447D                            | 2944A06305                | 2020. 01. 16 | 1 Year        |
| 5.   | Amplifier                     | HP               | 8449B                            | 3008A02678                | 2020. 02. 27 | 1 Year        |
| 6.   | Amplifier                     | HP               | 8449B                            | 3008A01284                | 2020. 05. 26 | 1 Year        |
| 7.   | Amplifier                     | Keysight         | 83051A                           | MY53010042                | 2020. 08. 05 | 1 Year        |
| 8.   | Loop Antenna                  | R&S              | HFH2-Z2                          | 891847/27                 | 2019. 12. 26 | 2 Years       |
| 9.   | Bilog Antenna                 | TESEQ            | CBL6112D                         | 33821                     | 2020. 01. 17 | 1 Year        |
| 10.  | Horn Antenna                  | EMCO             | 3115                             | 9609-4927                 | 2020. 06. 23 | 1 Year        |
| 11.  | Horn Antenna                  | EMCO             | 3117                             | 00135902                  | 2020. 03. 20 | 1 Year        |
| 12.  | Horn Antenna                  | COM-POWER        | AH-840                           | 101092                    | 2020 .05. 08 | 1 Year        |
| 13.  | 2.4GHz Notch Filter           | K&L              | 7NSL10-2441<br>.5/E130.5-O/<br>O | 3                         | N.C.R.       | N.C.R.        |
| 14.  | 3GHz Notch Filter             | Microwave        | H3G018G1                         | 484796                    | 2019. 08. 21 | 1 Year        |
| 15.  | Coaxial Cable                 | MIYAZAKI         | 5D2W                             | RE-11                     | 2020. 01. 31 | 1 Year        |
| 16.  | Cable                         | HUBER+SU<br>HNER | SUCOFLEX<br>106                  | RE-14                     | 2020. 01. 31 | 1 Year        |
| 17.  | Coaxial Cable                 | HUBER+SU<br>HNER | SUCOFLEX<br>104                  | RF<br>CABLE-01            | 2019. 09. 20 | 1 Year        |
| 18.  | Coaxial Cable                 | HUBER+<br>SUHNER | SUCOFLEX<br>102                  | No.1<br>18-40GHz<br>Cable | 2019. 09. 20 | 1 Year        |
| 19.  | Digital Thermo-Hygro<br>Meter | iMax             | HTC-1                            | No.1 3m A/C               | 2020. 04. 17 | 1 Year        |
| 20.  | Digital Thermo-Hygro<br>Meter | EVERY DAY        | E-512                            | RF-02                     | 2020. 04. 17 | 1 Year        |
| 21.  | Test Software                 | Audix            | e3                               | V6.120619c                | N.C.R.       | N.C.R.        |
| 22.  | Test Software                 | Audix            | e3                               | V6.110601                 | N.C.R.       | N.C.R.        |

## 4.3. RF Conducted Measurement

| Item | Type                             | Manufacturer                       | Model No.  | Serial No. | Cal. Date    | Cal. Interval |
|------|----------------------------------|------------------------------------|------------|------------|--------------|---------------|
| 1.   | Spectrum Analyzer                | Keysight                           | N9020B-544 | MY57120357 | 2020. 01. 10 | 1 Year        |
| 2.   | Power Meter                      | Anritsu                            | ML2495A    | 1145008    | 2019. 11. 06 | 1 Year        |
| 3.   | Power Sensor                     | Anritsu                            | MA2411B    | 1126096    | 2019. 11. 06 | 1 Year        |
| 4.   | Digital<br>Thermo-Hygro<br>Meter | Shenzhen<br>Datronn<br>Electronics | KT-905     | RF         | 2020. 04. 17 | 1 Year        |

## 5. CONDUCTED EMISSION

### 5.1. Block Diagram of Test Setup

#### 5.1.1. Block Diagram of EUT

Indicated as section 3.9

#### 5.1.2. Shielded Room Setup Diagram

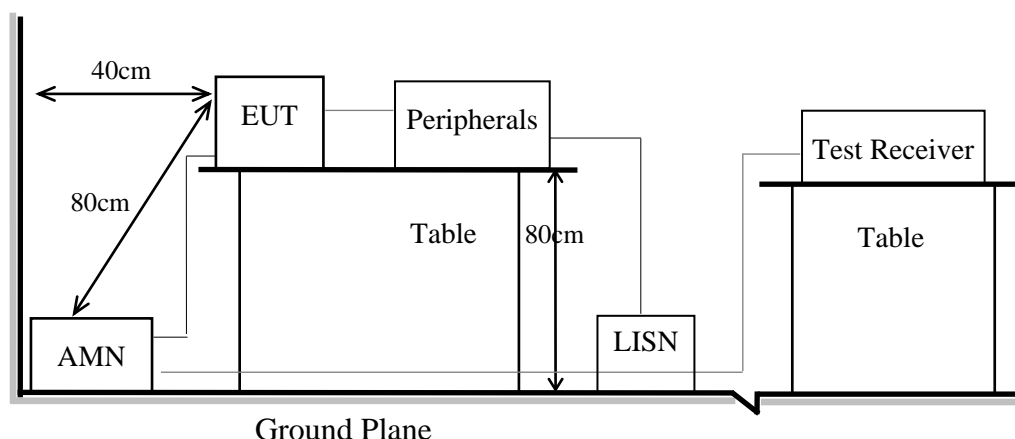

### 5.2. Conducted Emission Limit

| Frequency       | Conducted Limit    |                    |
|-----------------|--------------------|--------------------|
|                 | Quasi-Peak Level   | Average Level      |
| 150kHz ~ 500kHz | 66 ~ 56 dB $\mu$ V | 56 ~ 46 dB $\mu$ V |
| 500kHz ~ 5MHz   | 56 dB $\mu$ V      | 46 dB $\mu$ V      |
| 5MHz ~ 30MHz    | 60 dB $\mu$ V      | 50 dB $\mu$ V      |

Remark1.: If the average limit is met when using a Quasi-Peak detector, the measurement using the average detector is not required.

2.: The lower limit applies to the band edges.

### 5.3. Test Procedure

- 5.3.1. To set up the EUT as indicated in ANSI C63.10. The EUT was placed on the table which has 80 cm height to the ground and 40 cm distance to the conducting wall.
- 5.3.2. Power supplier of the EUT was connected to the AC mains through an Artificial Mains Network (A.M.N.).
- 5.3.3. The AC power supplies to all peripheral devices must be provided through line impedance stabilization network (L.I.S.N.)
- 5.3.4. Checking frequency range from 150kHz to 30 MHz and record the emission which does not have 20 dB below limit.



**Audix Technology Corp.**  
No. 53-11, Dingfu, Linkou, Dist.,  
New Taipei City 244, Taiwan

**Tel: +886 2 26099301**  
**Fax: +886 2 26099303**

---

## 5.4. Test Results

Please refer to Appendix A.

## 6. RADIATED EMISSION

### 6.1. Block Diagram of Test Setup

#### 6.1.1. Block Diagram of EUT

Indicated as section 3.9

#### 6.1.2. Setup Diagram for 9kHz-30MHz

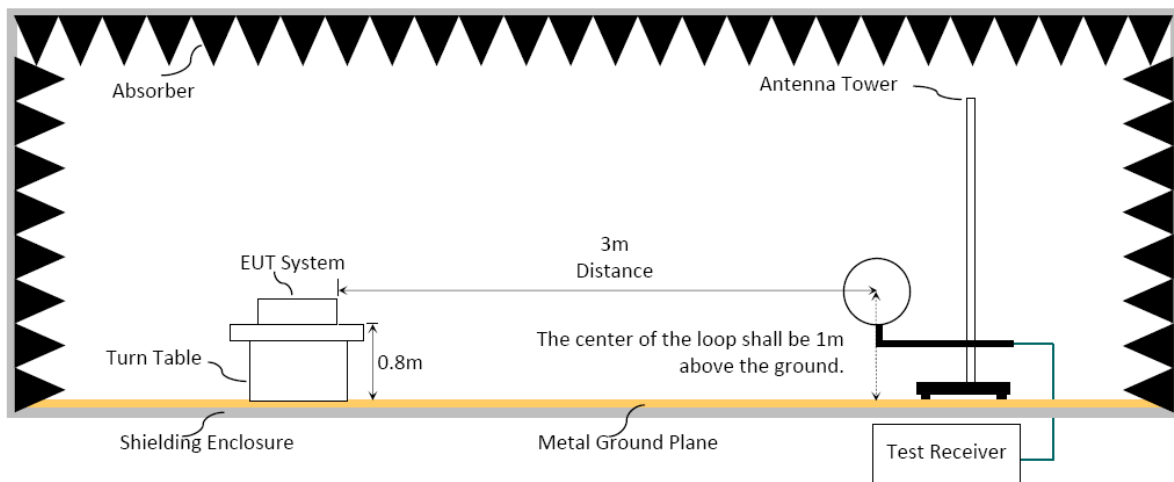

#### 6.1.3. Setup Diagram for 30-1000MHz

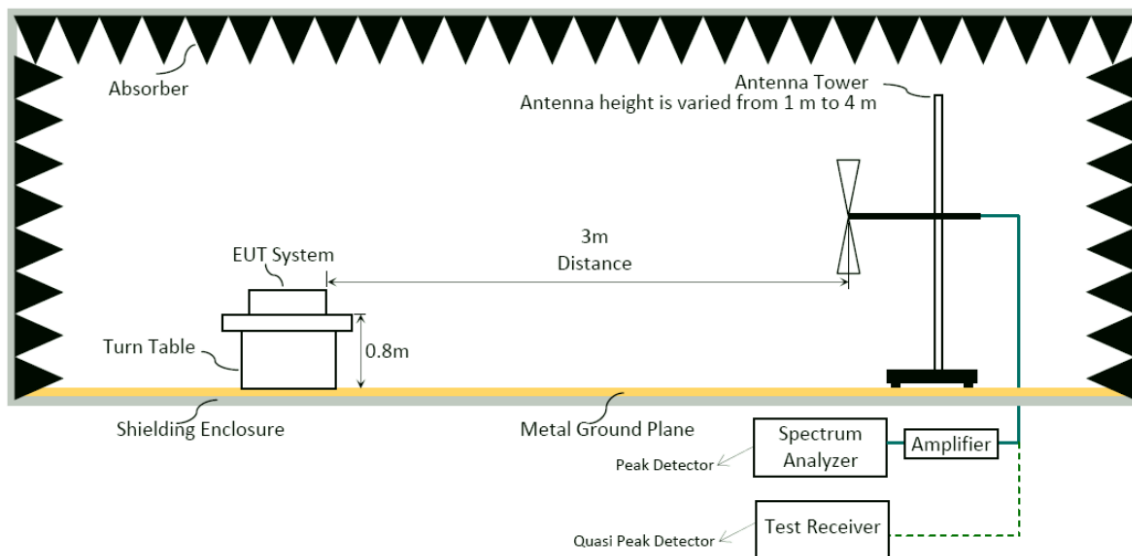

### 6.1.4. Setup Diagram for above 1GHz

#### Fully Anechoic Chamber

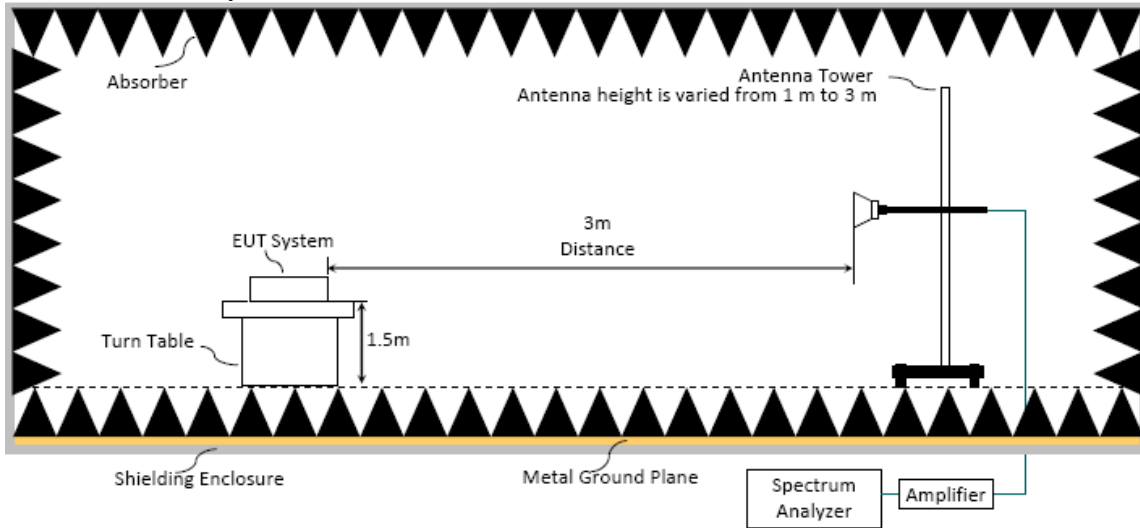

#### Semi Anechoic Chamber

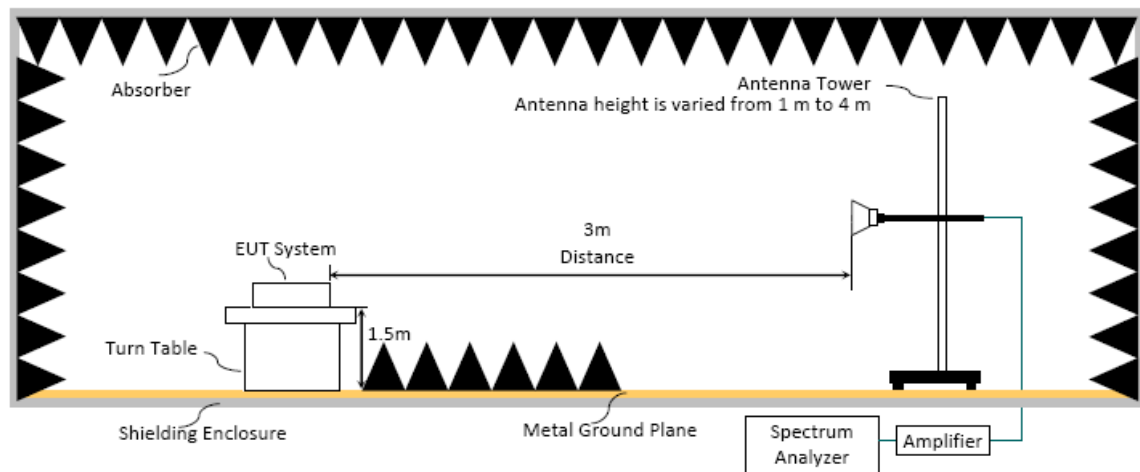



## 6.2. Radiated Emission Limits

In any 100kHz bandwidth outside the frequency band, the radio frequency power produced by the intentional radiator shall be at least 20dB below that in the 100kHz bandwidth within the band that contains the highest level. In addition, radiated emissions which fall in restricted bands, as defined in Section 15.205/RSS-Gen Section 8.10 table 6, must also comply with the radiated emission limits specified as below.

| Frequency (MHz) | Distance(m) | Limits  |             |
|-----------------|-------------|---|-------------|
|                 |             | dB $\mu$ V/m  | $\mu$ V/m   |
| 0.009 - 0.490   | 300         | 67.6-20 log f(kHz)                                      | 2400/f kHz  |
| 0.490 - 1.705   | 30          | 87.6-20 log f(kHz)                                      | 24000/f kHz |
| 1.705 - 30      | 30          | 29.5  | 30          |
| 30 - 88         | 3           | 40.0  | 100         |
| 88- 216         | 3           | 43.5  | 150         |
| 216- 960        | 3           | 46.0  | 200         |
| Above 960       | 3           | 54.0  | 500         |
| Above 1000      | 3           | 74.0 dB $\mu$ V/m (Peak)<br>54.0 dB $\mu$ V/m (Average) |             |

Remark : (1) dB $\mu$ V/m = 20 log ( $\mu$ V/m)

- (2) The tighter limit applies to the edge between two frequency bands.
- (3) Distance refers to the distance in meters between the measuring instrument antenna and the closed point of any part of the device or system.
- (4) Fundamental and emission fall within operation band are exempted from this section.
- (5) Pursuant to ANSI C63.10: 6.6.4.3, if the maximized peak measured value complies with the average limit, then it is unnecessary to perform an average measurement.

### 6.3. Test Procedure

#### Frequency Range 9kHz~30MHz:

The EUT setup on the turntable which has 0.8 m height to the ground. The turn table rotated 360 degrees and antenna fixed to 1 m to find the maximum emission level. In order to find the maximum emission, all of the interface cables were manipulated according to ANSI C63.10-2013 regulation.

- (1) RBW = 9kHz with peak and average detector.
- (2) Detector: average and peak (9kHz-490kHz)  
Q.P. (490kHz-30MHz)

#### Frequency Range 30MHz ~ 25GHz:

The EUT setup on the turn table which has 80cm (for 30-1000MHz) and 1.5m (for above 1GHz) height to the ground. The turn table rotated 360 degrees and antenna varied from 1 m to 4 m (for 30-1000MHz) and from 1m to 3m (for above 1GHz at fully Anechoic Chamber) or from 1 m to 4 m (for above 1GHz at Semi Anechoic Chamber) to find the maximum emission level. Both horizontal and vertical polarization are required. In order to find the maximum emission, all of the interface cables were manipulated according to ANSI C63.10-2013 regulation.

#### Frequency below 1GHz:

Spectrum Analyzer is used for pre-testing with following setting:

- (1) RBW = 120KHz
- (2) VBW  $\geq 3 \times$  RBW.
- (3) Detector = Peak.
- (4) Sweep time = auto.
- (5) Trace mode = max hold.
- (6) Allow sweeps to continue until the trace stabilizes.

Note 1: When peak-detected value is lower than limit that the measurement using the Q.P. detector is not required, otherwise using Q.P. for final measurement.

Note 2: When the radiated emissions limits are expressed in terms of the average value of the emissions, and pulsed operation is employed, the measurement field strength shall be determined by averaging over one complete pulse train, including blanking intervals, as long as the pulse train does not exceed 0.1 seconds.

#### Frequency above 1GHz to 10th harmonic(up to 25 GHz):

##### Peak Detector:

- (1) RBW = 1MHz
- (2) VBW  $\geq 3 \times$  RBW.
- (3) Detector = Peak.
- (4) Sweep time = auto.
- (5) Trace mode = max hold.
- (6) Allow sweeps to continue until the trace stabilizes.

Note: When peak-detected value is lower than limit that the measurement using the average detector is not required, otherwise using average detector for final measurement.

#### Average Detector:

##### Option 1:

- (1) RBW = 1MHz
- (2) VBW  $\geq 1/T$ .
- (3) Detector = Peak.
- (4) Sweep time = auto.
- (5) Trace mode = max hold.
- (6) Allow sweeps to continue until the trace stabilizes.

##### Option 2:

Average Emission Level = Peak Emission Level + D.C.C.F.

### 6.4. Measurement Result Explanation

Peak Emission Level = Antenna Factor + Cable Loss + Meter Reading (including Preamp factor if test used)

Average Emission Level = Antenna Factor + Cable Loss + Meter Reading (including Preamp factor if test used)

Average Emission Level = Peak Emission Level + DCCF

Duty Cycle Correction Factor (DCCF) =  $20\log(TX_{on}/TX_{on+off})$  presented in section 3.6

ERP = Peak Emission Level - 95.2dB - 2.14dB

### 6.5. Test Results

Please refer to Appendix A.

## 7. 20dB/OCCUPIED BANDWIDTH

### 7.1. Block Diagram of Test Setup

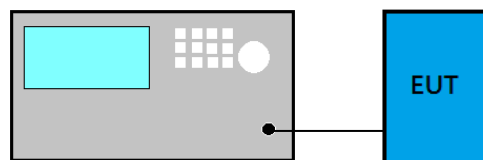

### 7.2. Specification Limits

Alternatively, frequency hopping systems operating in the 2400-2483.5MHz band may have hopping channel carrier frequencies that are separated by 25kHz or two-thirds of the 20dB bandwidth of the hopping channel, whichever is greater.

### 7.3. Test Procedure

Following measurement procedure is reference to ANSI C63.10:2013:

#### For 20dB Bandwidth

- (1) Set Span range 2~5 times the OBW
- (2) Set VBW  $\geq 3 \times$  RBW.
- (3) Detector = Peak.
- (4) Trace mode = Max hold.
- (5) Sweep = Auto couple.
- (6) Allow the trace to stabilize.
- (7) Setting channel bandwidth function x dB to -20 dB to record the final bandwidth.

#### For 99% Occupied Bandwidth

- (8) Set Span range 1.5~5 times the OBW
- (9) Set RBW close to 1% to 5% of OBW.
- (10) Set VBW  $\geq 3 \times$  RBW.
- (11) Detector = Peak.
- (12) Trace mode = Max hold
- (13) Sweep = Auto couple.
- (14) Allow the trace to stabilize.

### 7.4. Test Results

Please refer to Appendix A

## 8. CARRIER FREQUENCY SEPARATION

### 8.1. Block Diagram of Test Setup

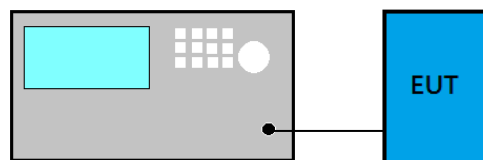

### 8.2. Specification Limits

Alternatively, frequency hopping systems operating in the 2400-2483.5MHz band may have hopping channel carrier frequencies that are separated by 25kHz or two-thirds of the 20dB bandwidth of the hopping channel, whichever is greater, provided the systems operate with an output no greater than 125mW.

### 8.3. Test Procedure

Following measurement procedure is reference to ANSI C63.10:2013:

- (1) Span = Wide enough to capture the peaks of two adjacent channels
- (2) RBW: Start with the RBW set to approximately 30% of the channel spacing; adjust as necessary to best identify the center of each individual channel.
- (3)  $VBW \geq RBW$
- (4) Sweep = Auto
- (5) Detector function = Peak
- (6) Trace = Max hold
- (7) Allow the trace to stabilize.

### 8.4. Test Results

Please refer to Appendix A

## 9. TIME OF OCCUPANCY

### 9.1. Block Diagram of Test Setup

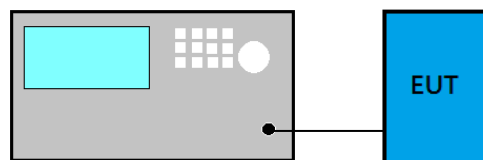

### 9.2. Specification Limits

Frequency hopping systems in the 2400-2483.5MHz shall use at least 15 non-overlapping channels. The average time of occupancy on any channel shall not be greater than 0.4 seconds within a period of 0.4 seconds multiplied by number of hopping channels employed.

### 9.3. Test Procedure

Following measurement procedure is reference to ANSI C63.10:2013:

- (1) Span: Zero span, centered on a hopping channel.
- (2) RBW shall be  $\leq$  channel spacing and where possible RBW should be set  $\gg 1/T$ , where T is the expected dwell time per channel.
- (3) Sweep: As necessary to capture the entire dwell time per hopping channel; where possible use a video trigger and trigger delay so that the transmitted signal starts a little to the right of the start of the plot. The trigger level might need slight adjustment to prevent triggering when the system hops on an adjacent channel; a second plot might be needed with a longer sweep time to show two successive hops on a channel.
- (4) Detector function = Peak
- (5) Trace = Max hold

### 9.4. Test Results

Please refer to Appendix A

## 10. NUMBER OF HOPPING CHANNELS

### 10.1. Block Diagram of Test Setup

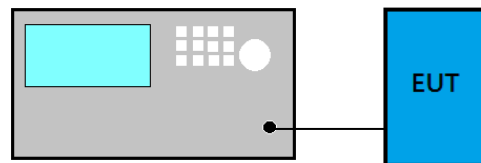

### 10.2. Specification Limits

Frequency hopping systems which use fewer than 20 hopping frequencies may employ intelligent hopping techniques to avoid interference to other transmissions. Frequency hopping systems may avoid or suppress transmissions on a particular hopping frequency provided that a minimum of 15 non-overlapping channels.

### 10.3. Test Procedure

Following measurement procedure is reference to ANSI C63.10:2013:

- (1) Span: The frequency band of operation. Depending on the number of channels the device supports, it may be necessary to divide the frequency range of operation across multiple spans, to allow the individual channels to be clearly seen.
- (2) RBW: To identify clearly the individual channels, set the RBW to less than 30% of the channel spacing or the 20 dB bandwidth, whichever is smaller.
- (3) VBW  $\geq$  RBW
- (4) Sweep = Auto
- (5) Detector function = Peak
- (6) Trace = m=Max hold
- (7) Allow the trace to stabilize.

### 10.4. Test Results

Please refer to Appendix A

## 11. MAXIMUM PEAK OUTPUT POWER

### 11.1. Block Diagram of Test Setup

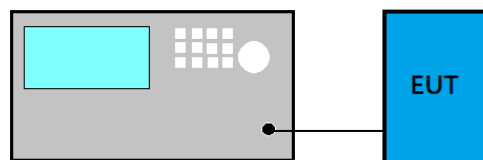

### 11.2. Specification Limits

The Limits of maximum Peak Output Power for frequency hopping systems in 2400-2483.5MHz is: 0.125Watt. (21dBm)

### 11.3. Test Procedure

Following measurement procedure is reference to ANSI C63.10:2013:

- (a) Use the following spectrum analyzer settings
  - (1) Span: Approximately five times the 20 dB bandwidth, centered on a hopping channel.
  - (2) RBW > 20 dB bandwidth of the emission being measured.
  - (3) VBW  $\geq$  RBW
  - (4) Sweep: Auto
  - (5) Detector function: Peak
  - (6) Trace: Max hold
- (b) Allow trace to stabilize.
- (c) Use the marker-to-peak function to set the marker to the peak of the emission.

### 11.4. Test Results

Please refer to Appendix A



## 12. EMISSION LIMITATIONS

### 12.1. Block Diagram of Test Setup

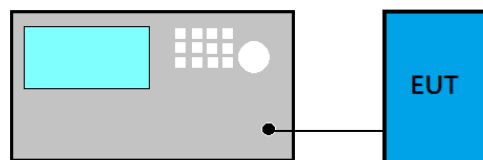

### 12.2. Specification Limits

In any 100kHz bandwidth outside the frequency band in which the spread spectrum or digitally modulated intentional radiator is operating, the radio frequency power that is produced by the intentional radiator shall be at least 20dB below that in the 100kHz bandwidth within the band that contains the highest level of the desired power, based on either an RF conducted or a radiated measurement. If the transmitter complies with the conducted power limits based on the use of RMS averaging over a time interval, that the required attenuation shall be 30 dB instead of 20 dB.

Attenuation below the general limits specified in Section 15.209(a)/RSS-Gen Section 8.9 table 4 is not required. In addition, radiated emissions which fall in restricted bands, as defined in Section 15.205(a)/RSS-Gen Section 8.10 table 6, must also comply with the radiated emission limits specified in Section 15.209(a)/RSS-Gen Section 8.9 table 4 (See Section 15.205(c)).

### 12.3. Test Procedure

Following measurement procedure is reference to ANSI C63.10:2013:

- (1) Set span wide enough to capture the peak level of the in-band emission and all spurious emissions; up to 10<sup>th</sup> harmonic.
- (2) RBW = 100 kHz
- (3) VBW  $\geq$  RBW
- (4) Sweep = Auto
- (5) Detector function = Peak
- (6) Trace = Max hold

### 12.4. Test Results

Please refer to Appendix A



## **13.DEVIATION TO TEST SPECIFICATIONS**

**【NONE】**



*Audix Technology Corp.  
No. 53-11, Dingfu, Linkou, Dist.,  
New Taipei City 244, Taiwan*

*Tel: +886 2 26099301  
Fax: +886 2 26099303*

---

# APPDNDIX A

## TEST DATA AND PLOTS

(Model: 17Z95N)

## TABLE OF CONTENTS

|   |           |
|---|-----------|
| <b>A.1 CONDUCTED EMISSION</b> .....                     | <b>2</b>  |
| <b>A.2 RADIATED EMISSION</b> .....                      | <b>6</b>  |
| A.2.1 Emissions within Restricted Frequency Bands.....  | 6         |
| A.2.2 Emissions outside the frequency band:.....        | 24        |
| A.2.3 Emissions in Non-restricted Frequency Bands:..... | 26        |
| <b>A.3 20dB BANDWIDTH</b> .....                         | <b>27</b> |
| A.3.1 20dB Bandwidth Result.....                        | 27        |
| A.3.2 Measurement Plots .....                           | 28        |
| <b>A.4 CARRIER FREQUENCY SEPARATION</b> .....           | <b>29</b> |
| <b>A.5 TIME OF OCCUPANCY</b> .....                      | <b>31</b> |
| A.5.1 Time of Occupancy .....                           | 31        |
| <b>A.6 NUMBER OF HOPPING CHANNELS</b> .....             | <b>41</b> |
| <b>A.7 MAXIMUM PEAK OUTPUT POWER</b> .....              | <b>42</b> |
| A.7.1 Maximum Peak Output Power .....                   | 42        |
| A.7.2 Measurement Plots .....                           | 43        |
| <b>A.8 EMISSION LIMITATIONS MEASUREMENT</b> .....       | <b>44</b> |
| A.8.1 Band Edge.....                                    | 44        |
| A.8.2 Spurious Emission .....                           | 46        |

## A.1 CONDUCTED EMISSION

|              |                               |            |          |
|--------------|-------------------------------|------------|----------|
| Test Date    | 2020/08/21                    | Temp./Hum. | 27°C/49% |
| Test Voltage | AC 120V 60Hz (Via AC Adapter) | Tested By  | Fate Lo  |
| Test SKU     | SKU #1 (with INPAQ Antenna)   |            |          |

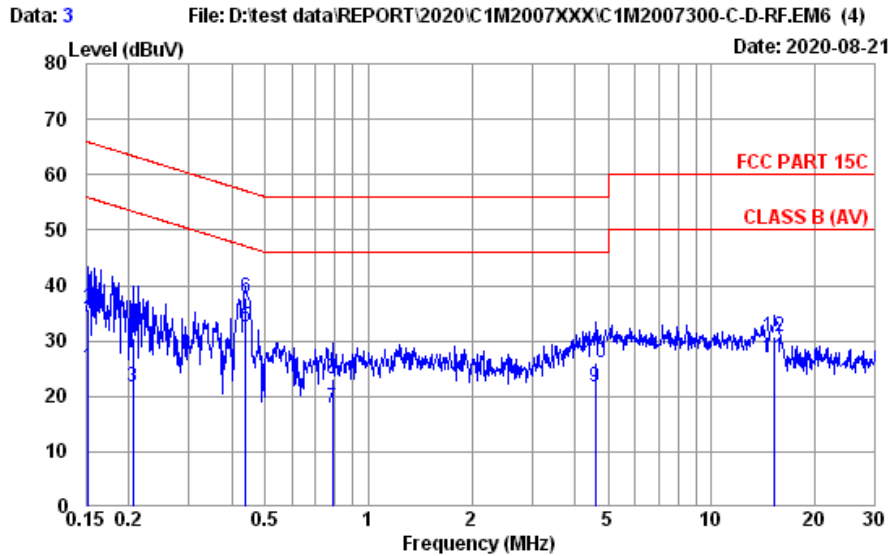

Site No. : No.8 Shielded Room Data No. : 3  
 Instrument 1 : Receiver ESR(774)  
 Instrument 2 : EHV432 (567)(A)|CE-08|ESH3-Z2 (354)  
 Limit : FCC PART 15C Phase : NEUTRAL  
 Environment : 27°C / 49% Engineer : Fate  
 EUT Model : 17295H(INPAQ) Test Rating : 120Vac/60Hz  
 Test Mode : Operating

|    | Freq. (MHz) | AMI Factor (dB) | Cable Loss (dB) | Pulse Att. (dB) | Reading (dBµV) | Emission Level (dBµV) | Limits (dBµV) | Margin (dB) | Remark  |
|----|-------------|-----------------|-----------------|-----------------|----------------|-----------------------|---------------|-------------|---------|
| 1  | 0.152       | 10.20           | 0.04            | 9.85            | 5.23           | 25.32                 | 55.87         | 30.55       | Average |
| 2  | 0.152       | 10.20           | 0.04            | 9.85            | 15.52          | 35.61                 | 65.87         | 30.26       | QP      |
| 3  | 0.206       | 10.20           | 0.04            | 9.85            | 1.51           | 21.60                 | 53.36         | 31.76       | Average |
| 4  | 0.206       | 10.20           | 0.04            | 9.85            | 10.42          | 30.51                 | 63.36         | 32.85       | QP      |
| 5  | 0.437       | 10.20           | 0.04            | 9.85            | 12.54          | 32.63                 | 47.11         | 14.48       | Average |
| 6  | 0.437       | 10.20           | 0.04            | 9.85            | 17.69          | 37.78                 | 57.11         | 19.33       | QP      |
| 7  | 0.783       | 10.20           | 0.05            | 9.86            | -2.24          | 17.87                 | 46.00         | 28.13       | Average |
| 8  | 0.783       | 10.20           | 0.05            | 9.86            | 2.95           | 23.06                 | 56.00         | 32.94       | QP      |
| 9  | 4.574       | 10.30           | 0.10            | 9.88            | 1.27           | 21.55                 | 46.00         | 24.45       | Average |
| 10 | 4.574       | 10.30           | 0.10            | 9.88            | 5.93           | 26.21                 | 56.00         | 29.79       | QP      |
| 11 | 15.307      | 10.71           | 0.16            | 9.94            | 6.12           | 26.93                 | 50.00         | 23.07       | Average |
| 12 | 15.307      | 10.71           | 0.16            | 9.94            | 9.83           | 30.64                 | 60.00         | 29.36       | QP      |

Remarks: 1. Emission Level= AMI Factor + Cable Loss + Pulse Att. + Reading.  
 2. If the average limit is met when using a quasi-peak detector, the EUT shall be deemed to meet both limits and measurement with average detector is unnecessary.

|              |                               |            |          |
|--------------|-------------------------------|------------|----------|
| Test Date    | 2020/08/21                    | Temp./Hum. | 27°C/49% |
| Test Voltage | AC 120V 60Hz (Via AC Adapter) | Tested By  | Fate Lo  |
| Test SKU     | SKU #1 (with INPAQ Antenna)   |            |          |

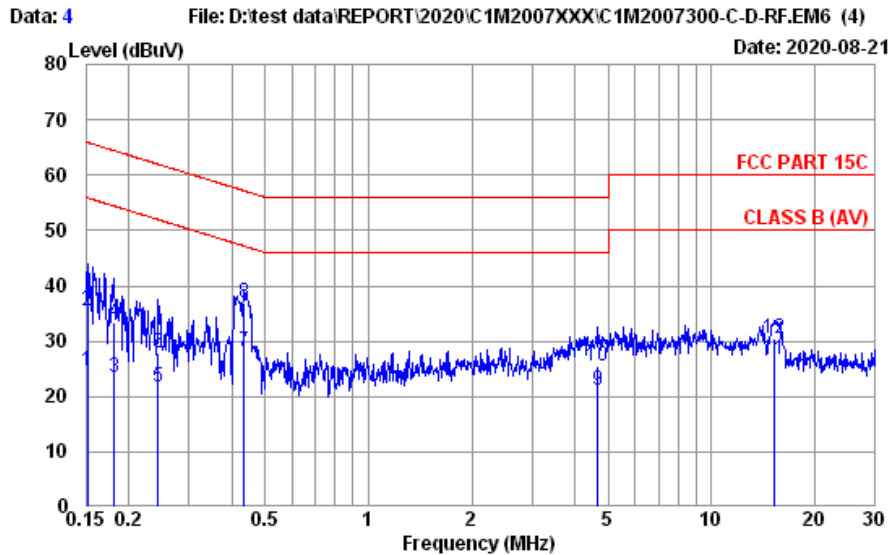

Site No. : No.8 Shielded Room Data No. : 4  
 Instrument 1 : Receiver ESR(774)  
 Instrument 2 : EHV432 (567)(A)|CE-08|ESH3-Z2 (354)  
 Limit : FCC PART 15C Phase : LINE  
 Environment : 27°C / 49% Engineer : Fate  
 EUT Model : 17Z95H(INPAQ) Test Rating : 120Vac/60Hz  
 Test Mode : Operating

|    | Freq. (MHz) | AMN Factor (dB) | Cable Loss (dB) | Pulse Att. (dB) | Reading (dBμV) | Emission Level (dBμV) | Limits (dBμV) | Margin (dB) | Remark  |
|----|-------------|-----------------|-----------------|-----------------|----------------|-----------------------|---------------|-------------|---------|
| 1  | 0.152       | 10.20           | 0.04            | 9.85            | 4.47           | 24.56                 | 55.91         | 31.35       | Average |
| 2  | 0.152       | 10.20           | 0.04            | 9.85            | 15.46          | 35.55                 | 65.91         | 30.36       | QP      |
| 3  | 0.182       | 10.20           | 0.04            | 9.85            | 3.25           | 23.34                 | 54.42         | 31.08       | Average |
| 4  | 0.182       | 10.20           | 0.04            | 9.85            | 13.39          | 33.48                 | 64.42         | 30.94       | QP      |
| 5  | 0.244       | 10.20           | 0.04            | 9.85            | 1.50           | 21.59                 | 51.95         | 30.36       | Average |
| 6  | 0.244       | 10.20           | 0.04            | 9.85            | 7.65           | 27.74                 | 61.95         | 34.21       | QP      |
| 7  | 0.433       | 10.20           | 0.04            | 9.85            | 7.95           | 28.04                 | 47.20         | 19.16       | Average |
| 8  | 0.433       | 10.20           | 0.04            | 9.85            | 16.74          | 36.83                 | 57.20         | 20.37       | QP      |
| 9  | 4.647       | 10.30           | 0.10            | 9.88            | 0.78           | 21.06                 | 46.00         | 24.94       | Average |
| 10 | 4.647       | 10.30           | 0.10            | 9.88            | 5.11           | 25.39                 | 56.00         | 30.61       | QP      |
| 11 | 15.226      | 10.50           | 0.16            | 9.94            | 5.96           | 26.56                 | 50.00         | 23.44       | Average |
| 12 | 15.226      | 10.50           | 0.16            | 9.94            | 9.89           | 30.49                 | 60.00         | 29.51       | QP      |

Remarks: 1. Emission Level= AMN Factor + Cable Loss + Pulse Att. + Reading.  
 2. If the average limit is met when using a quasi-peak detector, the EUT shall be deemed to meet both limits and measurement with average detector is unnecessary.

|              |                                    |            |          |
|--------------|------------------------------------|------------|----------|
| Test Date    | 2020/08/21                         | Temp./Hum. | 27°C/49% |
| Test Voltage | AC 120V 60Hz (Via AC Adapter)      | Tested By  | Fate Lo  |
| Test SKU     | SKU #2 (with LUXSHARE-ICT Antenna) |            |          |

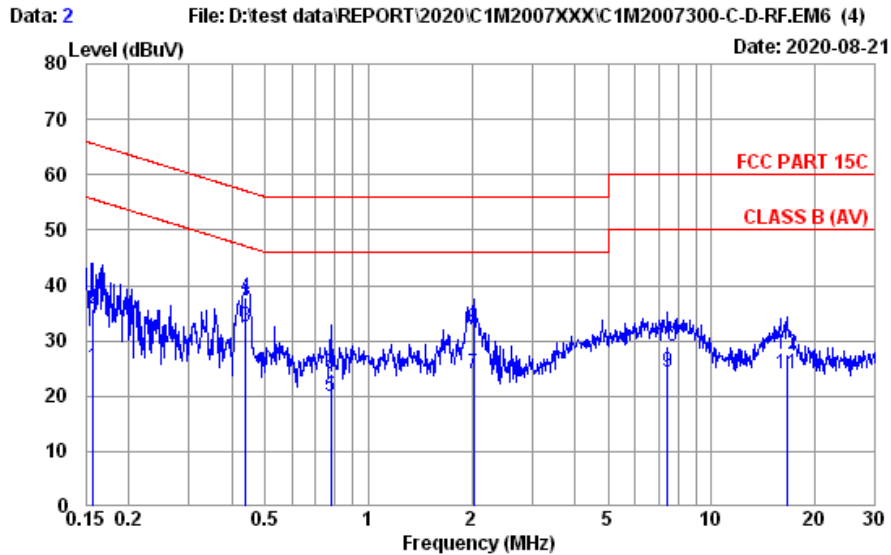

|              |                                       |             |               |
|--------------|---------------------------------------|-------------|---------------|
| Site No.     | : No.8 Shielded Room                  | Data No.    | : 2           |
| Instrument 1 | : Receiver ESR(774)                   |             |               |
| Instrument 2 | : EHV432 (567)(A) CE-08 ESH3-Z2 (354) |             |               |
| Limit        | : FCC PART 15C                        | Phase       | : NEUTRAL     |
| Environment  | : 27°C / 49%                          | Engineer    | : Fate        |
| EUT Model    | : 17295H(LUXSHARE-ICT)                | Test Rating | : 120Vac/60Hz |
| Test Mode    | : Operating                           |             |               |

|    | Freq. (MHz) | AMI Factor (dB) | Cable Loss (dB) | Pulse Att. (dB) | Reading (dBµV) | Emission Level (dBµV) | Limits (dBµV) | Margin (dB) | Remark  |
|----|-------------|-----------------|-----------------|-----------------|----------------|-----------------------|---------------|-------------|---------|
| 1  | 0.157       | 10.20           | 0.04            | 9.85            | 5.06           | 25.15                 | 55.60         | 30.45       | Average |
| 2  | 0.157       | 10.20           | 0.04            | 9.85            | 15.52          | 35.61                 | 65.60         | 29.99       | QP      |
| 3  | 0.437       | 10.20           | 0.04            | 9.85            | 12.45          | 32.54                 | 47.11         | 14.57       | Average |
| 4  | 0.437       | 10.20           | 0.04            | 9.85            | 17.83          | 37.92                 | 57.11         | 19.19       | QP      |
| 5  | 0.775       | 10.20           | 0.05            | 9.86            | -0.31          | 19.80                 | 46.00         | 26.20       | Average |
| 6  | 0.775       | 10.20           | 0.05            | 9.86            | 3.79           | 23.90                 | 56.00         | 32.10       | QP      |
| 7  | 2.023       | 10.30           | 0.07            | 9.86            | 3.76           | 23.99                 | 46.00         | 22.01       | Average |
| 8  | 2.023       | 10.30           | 0.07            | 9.86            | 12.01          | 32.24                 | 56.00         | 23.76       | QP      |
| 9  | 7.446       | 10.42           | 0.12            | 9.90            | 3.99           | 24.43                 | 50.00         | 25.57       | Average |
| 10 | 7.446       | 10.42           | 0.12            | 9.90            | 8.63           | 29.07                 | 60.00         | 30.93       | QP      |
| 11 | 16.573      | 10.77           | 0.17            | 9.95            | 3.06           | 23.95                 | 50.00         | 26.05       | Average |
| 12 | 16.573      | 10.77           | 0.17            | 9.95            | 6.60           | 27.49                 | 60.00         | 32.51       | QP      |

Remarks: 1. Emission Level= AMI Factor + Cable Loss + Pulse Att. + Reading.  
 2. If the average limit is met when using a quasi-peak detector, the EUT shall be deemed to meet both limits and measurement with average detector is unnecessary.

|              |                                    |            |          |
|--------------|------------------------------------|------------|----------|
| Test Date    | 2020/08/21                         | Temp./Hum. | 27°C/49% |
| Test Voltage | AC 120V 60Hz (Via AC Adapter)      | Tested By  | Fate Lo  |
| Test SKU     | SKU #2 (with LUXSHARE-ICT Antenna) |            |          |

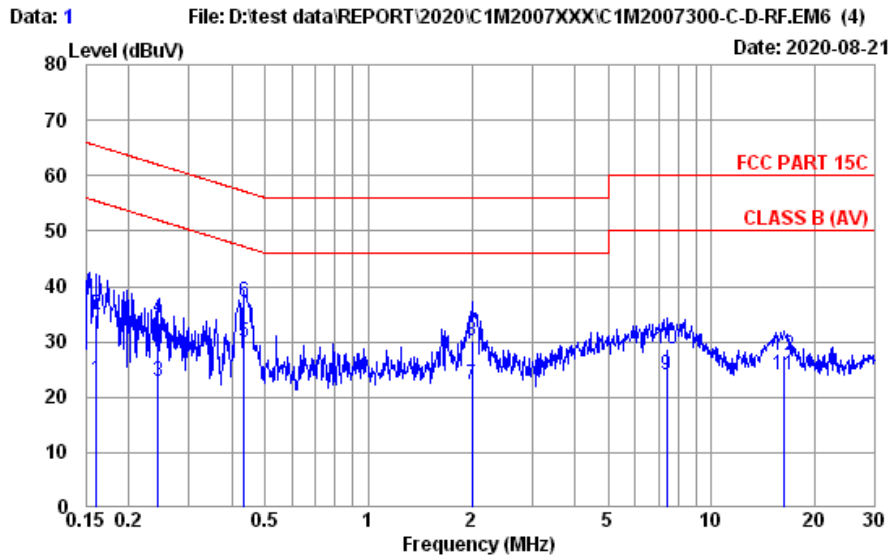

Site No. : No.8 Shielded Room Data No. : 1  
 Instrument 1 : Receiver ESR(774)  
 Instrument 2 : EHV432 (567)(A)|CE-08|ESH3-Z2 (354)  
 Limit : FCC PART 15C Phase : LINE  
 Environment : 27°C / 49% Engineer : Fate  
 EUT Model : 17295H(LUXSHARE-ICT) Test Rating : 120Vac/60Hz  
 Test Mode : Operating

|    | Freq.<br>(MHz) | AMH<br>Factor<br>(dB) | Cable<br>Loss<br>(dB) | Pulse<br>Att.<br>(dB) | Reading<br>(dBµV) | Emission<br>Level<br>(dBµV) | Limits<br>(dBµV) | Margin<br>(dB) | Remark  |
|----|----------------|-----------------------|-----------------------|-----------------------|-------------------|-----------------------------|------------------|----------------|---------|
| 1  | 0.161          | 10.20                 | 0.04                  | 9.85                  | 3.20              | 23.29                       | 55.43            | 32.14          | Average |
| 2  | 0.161          | 10.20                 | 0.04                  | 9.85                  | 14.72             | 34.81                       | 65.43            | 30.62          | QP      |
| 3  | 0.243          | 10.20                 | 0.04                  | 9.85                  | 2.65              | 22.74                       | 52.00            | 29.26          | Average |
| 4  | 0.243          | 10.20                 | 0.04                  | 9.85                  | 14.14             | 34.23                       | 62.00            | 27.77          | QP      |
| 5  | 0.433          | 10.20                 | 0.04                  | 9.85                  | 9.88              | 29.97                       | 47.20            | 17.23          | Average |
| 6  | 0.433          | 10.20                 | 0.04                  | 9.85                  | 17.20             | 37.29                       | 57.20            | 19.91          | QP      |
| 7  | 2.001          | 10.30                 | 0.07                  | 9.86                  | 1.95              | 22.18                       | 46.00            | 23.82          | Average |
| 8  | 2.001          | 10.30                 | 0.07                  | 9.86                  | 9.95              | 30.18                       | 56.00            | 25.82          | QP      |
| 9  | 7.407          | 10.32                 | 0.12                  | 9.90                  | 3.66              | 24.00                       | 50.00            | 26.00          | Average |
| 10 | 7.407          | 10.32                 | 0.12                  | 9.90                  | 8.30              | 28.64                       | 60.00            | 31.36          | QP      |
| 11 | 16.312         | 10.53                 | 0.17                  | 9.95                  | 3.45              | 24.10                       | 50.00            | 25.90          | Average |
| 12 | 16.312         | 10.53                 | 0.17                  | 9.95                  | 6.92              | 27.57                       | 60.00            | 32.43          | QP      |

Remarks: 1. Emission Level= AMH Factor + Cable Loss + Pulse Att. + Reading.  
 2. If the average limit is met when using a quasi-peak detector,  
 the EUT shall be deemed to meet both limits and measurement  
 with average detector is unnecessary.



## A.2 RADIATED EMISSION

|              |                               |            |                 |
|--------------|-------------------------------|------------|-----------------|
| Test Date    | 2020/08/14~20                 | Temp./Hum. | 24~25°C /49~50% |
| Test Voltage | AC 120V 60Hz (Via AC Adapter) | Tested By  | Kuper Hsu       |

### A.2.1 Emissions within Restricted Frequency Bands

#### A.2.1.1 Frequency 9kHz~30MHz

**The emissions (9kHz~30MHz) not reported for there is no emission be found.**

#### A.2.1.2 Frequency Below 1 GHz

**Test SKU: SKU #1 (with INPAQ Antenna)**

|      |      |           |            |
|------|------|-----------|------------|
| Mode | GFSK | Frequency | TX 2480MHz |
|------|------|-----------|------------|

#### Antenna at Horizontal Polarization

| Emission Frequency (MHz) | Antenna Factor (dB/m) | Cable Loss (dB) | Preamplifier Gain (dB) | Read Level (dBμV) | Emission Level (dBμV/m) | Limits (dBμV/m) | Margin (dB) | Detector |
|--------------------------|-----------------------|-----------------|------------------------|-------------------|-------------------------|-----------------|-------------|----------|
| 30.000                   | 24.20                 | 1.20            | 26.53                  | 27.62             | 26.49                   | 40.00           | 13.51       | Peak     |
| 56.190                   | 13.30                 | 1.76            | 26.47                  | 35.32             | 23.91                   | 40.00           | 16.09       | Peak     |
| 154.160                  | 16.94                 | 3.10            | 26.04                  | 32.04             | 26.04                   | 43.50           | 17.46       | Peak     |
| 259.890                  | 18.82                 | 4.12            | 25.76                  | 32.95             | 30.13                   | 46.00           | 15.87       | Peak     |
| 540.220                  | 24.04                 | 6.97            | 27.33                  | 29.52             | 33.20                   | 46.00           | 12.80       | Peak     |
| 923.370                  | 26.96                 | 8.82            | 27.07                  | 28.78             | 37.49                   | 46.00           | 8.51        | Peak     |

#### Antenna at Vertical Polarization

| Emission Frequency (MHz) | Antenna Factor (dB/m) | Cable Loss (dB) | Preamplifier Gain (dB) | Read Level (dBμV) | Emission Level (dBμV/m) | Limits (dBμV/m) | Margin (dB) | Detector |
|--------------------------|-----------------------|-----------------|------------------------|-------------------|-------------------------|-----------------|-------------|----------|
| 35.820                   | 21.56                 | 1.38            | 26.52                  | 39.96             | 36.38                   | 40.00           | 3.62        | Peak     |
| 75.590                   | 12.87                 | 2.11            | 26.39                  | 41.60             | 30.19                   | 40.00           | 9.81        | Peak     |
| 100.810                  | 16.84                 | 2.44            | 26.31                  | 35.99             | 28.96                   | 43.50           | 14.54       | Peak     |
| 256.010                  | 18.77                 | 4.08            | 25.77                  | 30.22             | 27.30                   | 46.00           | 18.70       | Peak     |
| 732.280                  | 25.36                 | 7.78            | 27.47                  | 29.31             | 34.98                   | 46.00           | 11.02       | Peak     |
| 940.830                  | 27.07                 | 8.90            | 27.01                  | 28.87             | 37.83                   | 46.00           | 8.17        | Peak     |

**Test SKU: SKU #2 (with LUXSHARE-ICT Antenna)**

|      |      |           |            |
|------|------|-----------|------------|
| Mode | GFSK | Frequency | TX 2480MHz |
|------|------|-----------|------------|

**Antenna at Horizontal Polarization**

| Emission Frequency (MHz) | Antenna Factor (dB/m) | Cable Loss (dB) | Preamplifier Gain (dB) | Read Level (dBμV) | Emission Level (dBμV/m) | Limits (dBμV/m) | Margin (dB) | Detector |
|--------------------------|-----------------------|-----------------|------------------------|-------------------|-------------------------|-----------------|-------------|----------|
| 31.940                   | 23.35                 | 1.26            | 26.53                  | 30.50             | 28.58                   | 40.00           | 11.42       | Peak     |
| 125.060                  | 18.55                 | 2.75            | 26.17                  | 34.08             | 29.21                   | 43.50           | 14.29       | Peak     |
| 250.190                  | 18.70                 | 4.02            | 25.78                  | 39.59             | 36.53                   | 46.00           | 9.47        | Peak     |
| 317.120                  | 19.74                 | 4.81            | 25.86                  | 32.75             | 31.44                   | 46.00           | 14.56       | Peak     |
| 868.080                  | 26.61                 | 8.53            | 27.24                  | 28.77             | 36.67                   | 46.00           | 9.33        | Peak     |
| 990.300                  | 27.34                 | 9.12            | 26.87                  | 28.38             | 37.97                   | 54.00           | 16.03       | Peak     |

**Antenna at Vertical Polarization**

| Emission Frequency (MHz) | Antenna Factor (dB/m) | Cable Loss (dB) | Preamplifier Gain (dB) | Read Level (dBμV) | Emission Level (dBμV/m) | Limits (dBμV/m) | Margin (dB) | Detector |
|--------------------------|-----------------------|-----------------|------------------------|-------------------|-------------------------|-----------------|-------------|----------|
| 32.910                   | 22.98                 | 1.29            | 0.00                   | 9.30              | 33.57                   | 40.00           | 6.43        | Peak     |
| 43.580                   | 17.06                 | 1.56            | 26.51                  | 44.85             | 36.96                   | 40.00           | 3.04        | Peak     |
| 100.810                  | 16.84                 | 2.44            | 26.31                  | 40.95             | 33.92                   | 43.50           | 9.58        | Peak     |
| 250.190                  | 18.70                 | 4.02            | 25.78                  | 35.96             | 32.90                   | 46.00           | 13.10       | Peak     |
| 830.250                  | 26.33                 | 8.31            | 27.32                  | 29.96             | 37.28                   | 46.00           | 8.72        | Peak     |
| 987.390                  | 27.32                 | 9.10            | 26.87                  | 29.07             | 38.62                   | 54.00           | 15.38       | Peak     |

A.2.1.3 Frequency Above 1 GHz to 10<sup>th</sup> harmonics

**Band Edge:**

**Test SKU: SKU #1 (with INPAQ Antenna)**

|      |      |           |            |
|------|------|-----------|------------|
| Mode | GFSK | Frequency | TX 2402MHz |
|------|------|-----------|------------|

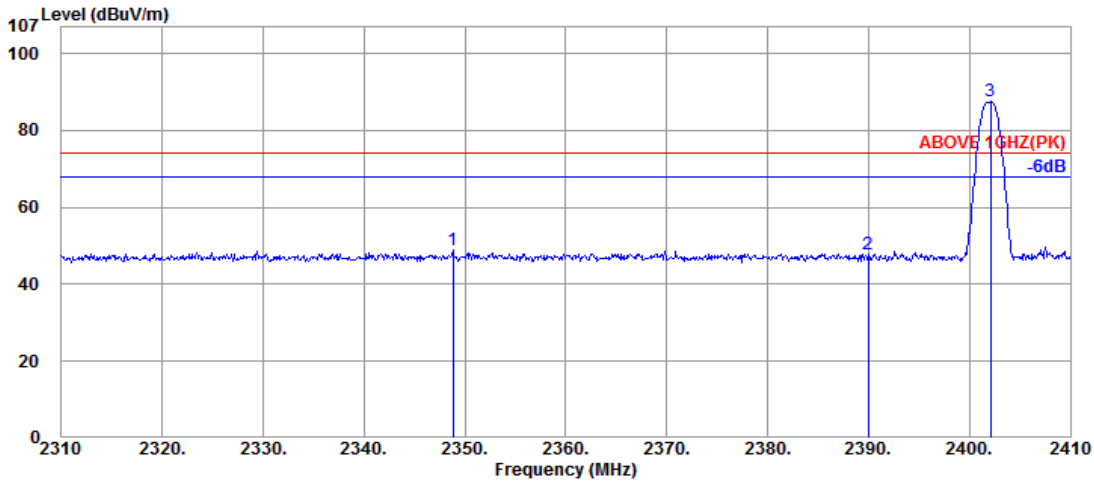

Antenna at Horizontal Polarization

| Emission Frequency (MHz) | Antenna Factor (dB/m) | Cable Loss (dB) | Preamplifier Gain (dB) | Read Level (dBμV) | Emission Level (dBμV/m) | Limits (dBμV/m) | Margin (dB) | Detector |
|--------------------------|-----------------------|-----------------|------------------------|-------------------|-------------------------|-----------------|-------------|----------|
| 2348.800                 | 32.24                 | 8.48            | 34.57                  | 42.87             | 49.02                   | 74.00           | 24.98       | Peak     |
| 2390.000                 | 32.44                 | 8.52            | 34.58                  | 41.32             | 47.70                   | 74.00           | 26.30       | Peak     |
| @ 2402.100               | 32.50                 | 8.52            | 34.59                  | 81.05             | 87.48                   | ---             | ---         | Peak     |

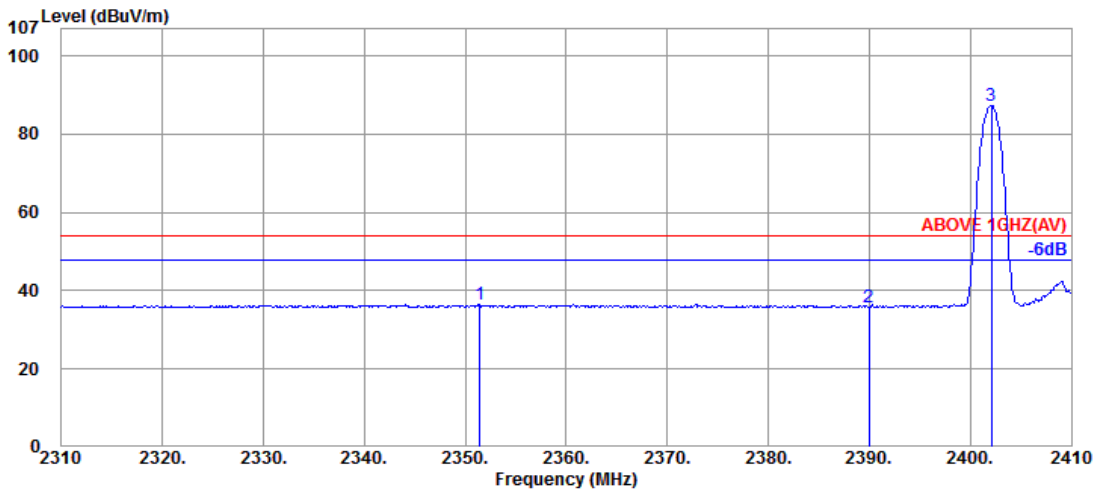

Antenna at Horizontal Polarization

| Emission Frequency (MHz) | Antenna Factor (dB/m) | Cable Loss (dB) | Preamplifier Gain (dB) | Read Level (dBμV) | Emission Level (dBμV/m) | Limits (dBμV/m) | Margin (dB) | Detector |
|--------------------------|-----------------------|-----------------|------------------------|-------------------|-------------------------|-----------------|-------------|----------|
| 2351.400                 | 32.30                 | 8.48            | 34.57                  | 30.29             | 36.50                   | 54.00           | 17.50       | Average  |
| 2390.000                 | 32.44                 | 8.52            | 34.58                  | 29.52             | 35.90                   | 54.00           | 18.10       | Average  |
| @ 2402.100               | 32.50                 | 8.52            | 34.59                  | 80.85             | 87.28                   | ---             | ---         | Average  |

Remark: The “@” means fundamental frequency, it is ignored in this section.

|      |      |           |            |
|------|------|-----------|------------|
| Mode | GFSK | Frequency | TX 2402MHz |
|------|------|-----------|------------|

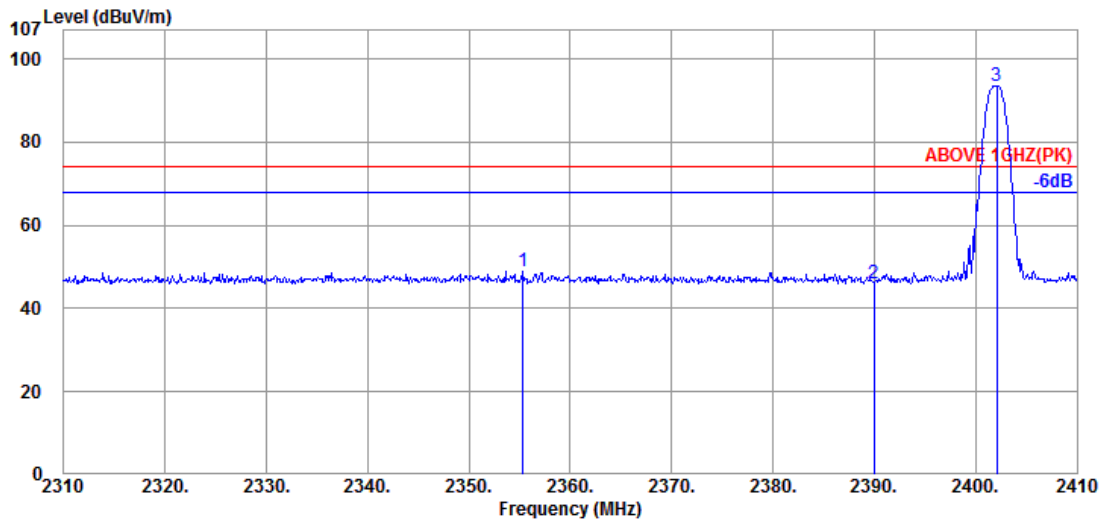

Antenna at Vertical Polarization

| Emission Frequency (MHz) | Antenna Factor (dB/m) | Cable Loss (dB) | Preamplifier Gain (dB) | Read Level (dBμV) | Emission Level (dBμV/m) | Limits (dBμV/m) | Margin (dB) | Detector |
|--------------------------|-----------------------|-----------------|------------------------|-------------------|-------------------------|-----------------|-------------|----------|
| 2355.300                 | 32.30                 | 8.49            | 34.57                  | 42.64             | 48.86                   | 74.00           | 25.14       | Peak     |
| 2390.000                 | 32.44                 | 8.52            | 34.58                  | 39.80             | 46.18                   | 74.00           | 27.82       | Peak     |
| @ 2402.100               | 32.50                 | 8.52            | 34.59                  | 87.11             | 93.54                   | ---             | ---         | Peak     |

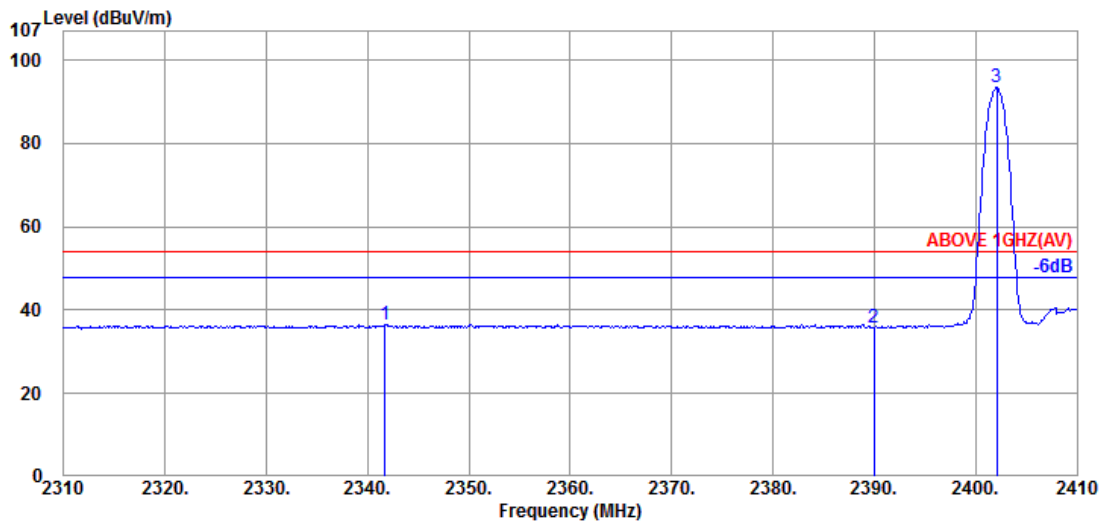

Antenna at Vertical Polarization

| Emission Frequency (MHz) | Antenna Factor (dB/m) | Cable Loss (dB) | Preamplifier Gain (dB) | Read Level (dBμV) | Emission Level (dBμV/m) | Limits (dBμV/m) | Margin (dB) | Detector |
|--------------------------|-----------------------|-----------------|------------------------|-------------------|-------------------------|-----------------|-------------|----------|
| 2341.700                 | 32.17                 | 8.48            | 34.57                  | 30.50             | 36.58                   | 54.00           | 17.42       | Average  |
| 2390.000                 | 32.44                 | 8.52            | 34.58                  | 29.55             | 35.93                   | 54.00           | 18.07       | Average  |
| @ 2402.100               | 32.50                 | 8.52            | 34.59                  | 86.94             | 93.37                   | ---             | ---         | Average  |

Remark: The “@” means fundamental frequency, it is ignored in this section.

|      |      |           |            |
|------|------|-----------|------------|
| Mode | GFSK | Frequency | TX 2480MHz |
|------|------|-----------|------------|

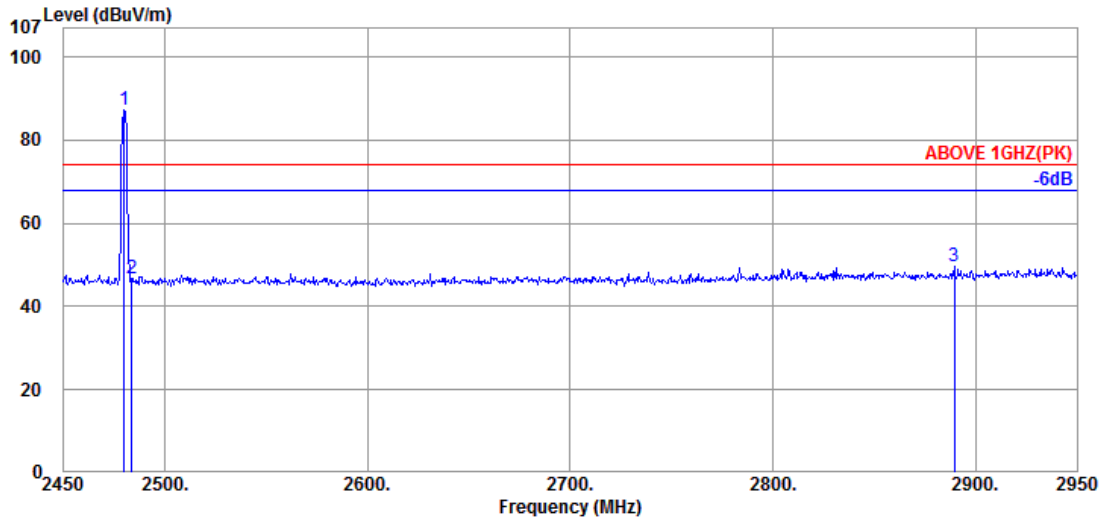

**Antenna at Horizontal Polarization**

| Emission Frequency (MHz) | Antenna Factor (dB/m) | Cable Loss (dB) | Preamplifier Gain (dB) | Read Level (dBμV) | Emission Level (dBμV/m) | Limits (dBμV/m) | Margin (dB) | Detector |
|--------------------------|-----------------------|-----------------|------------------------|-------------------|-------------------------|-----------------|-------------|----------|
| @ 2480.000               | 32.11                 | 8.58            | 34.60                  | 81.24             | 87.33                   | ---             | ---         | Peak     |
| 2483.500                 | 32.14                 | 8.58            | 34.61                  | 40.46             | 46.57                   | 74.00           | 27.43       | Peak     |
| 2889.500                 | 32.85                 | 8.68            | 34.68                  | 42.95             | 49.80                   | 74.00           | 24.20       | Peak     |

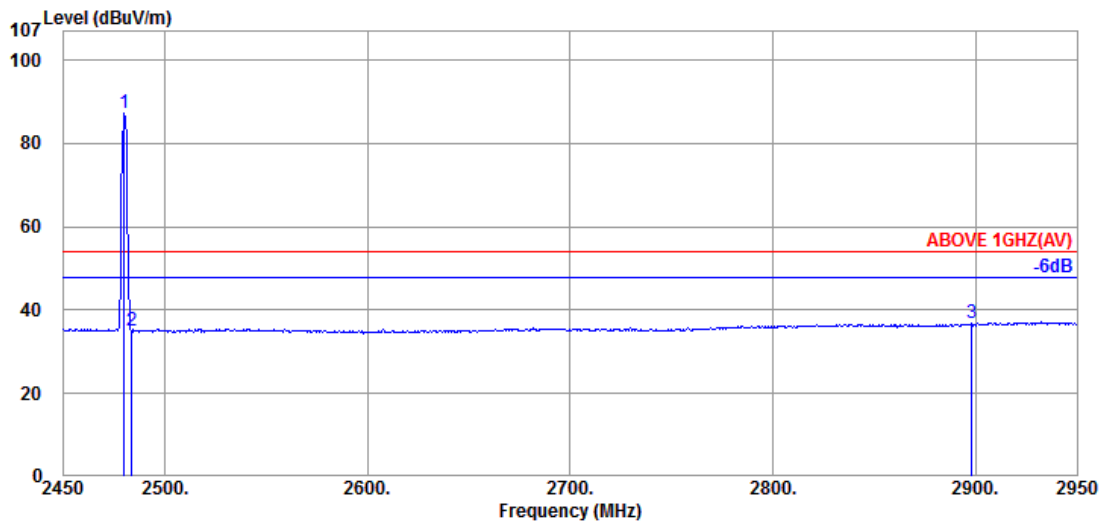

**Antenna at Horizontal Polarization**

| Emission Frequency (MHz) | Antenna Factor (dB/m) | Cable Loss (dB) | Preamplifier Gain (dB) | Read Level (dBμV) | Emission Level (dBμV/m) | Limits (dBμV/m) | Margin (dB) | Detector |
|--------------------------|-----------------------|-----------------|------------------------|-------------------|-------------------------|-----------------|-------------|----------|
| @ 2480.000               | 32.11                 | 8.58            | 34.60                  | 81.02             | 87.11                   | ---             | ---         | Average  |
| 2483.500                 | 32.14                 | 8.58            | 34.61                  | 29.05             | 35.16                   | 54.00           | 18.84       | Average  |
| 2898.000                 | 32.80                 | 8.69            | 34.68                  | 30.01             | 36.82                   | 54.00           | 17.18       | Average  |

Remark: The “@” means fundamental frequency, it is ignored in this section.

|      |      |           |            |
|------|------|-----------|------------|
| Mode | GFSK | Frequency | TX 2480MHz |
|------|------|-----------|------------|

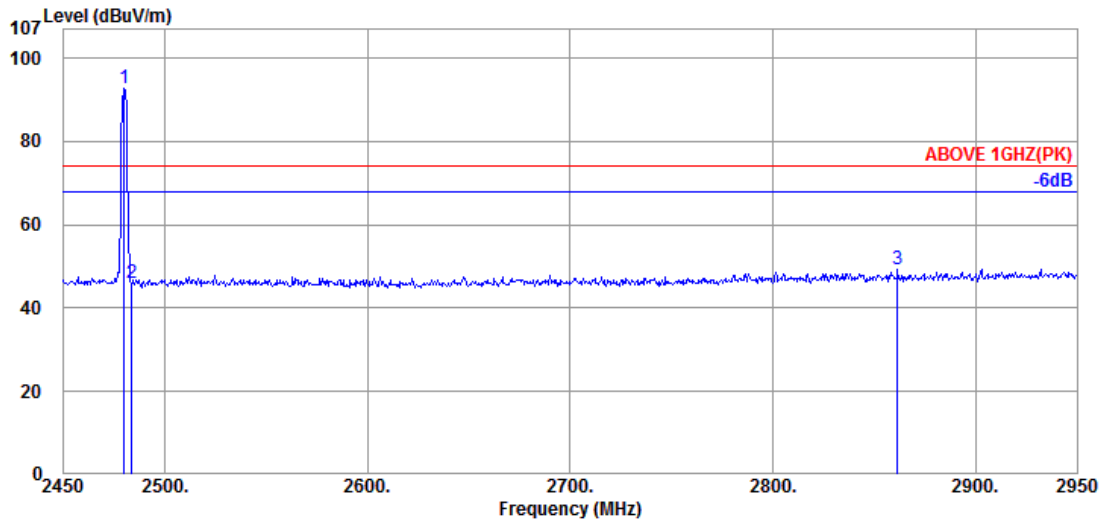

Antenna at Vertical Polarization

| Emission Frequency (MHz) | Antenna Factor (dB/m) | Cable Loss (dB) | Preamplifier Gain (dB) | Read Level (dBμV) | Emission Level (dBμV/m) | Limits (dBμV/m) | Margin (dB) | Detector |
|--------------------------|-----------------------|-----------------|------------------------|-------------------|-------------------------|-----------------|-------------|----------|
| @ 2480.000               | 32.11                 | 8.58            | 34.60                  | 86.85             | 92.94                   | ---             | ---         | Peak     |
| 2483.500                 | 32.14                 | 8.58            | 34.61                  | 39.79             | 45.90                   | 74.00           | 28.10       | Peak     |
| 2861.500                 | 33.00                 | 8.68            | 34.68                  | 42.40             | 49.40                   | 74.00           | 24.60       | Peak     |

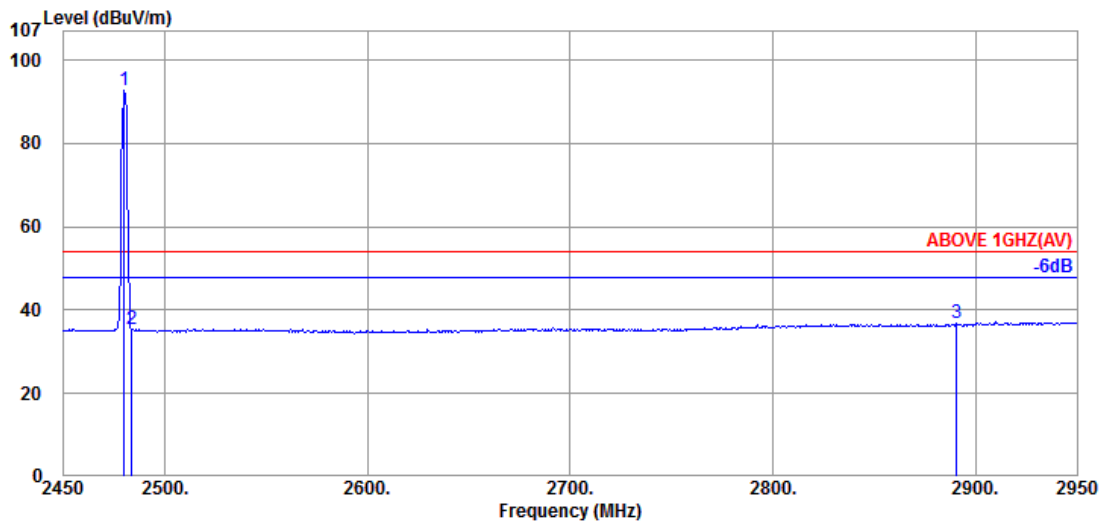

Antenna at Vertical Polarization

| Emission Frequency (MHz) | Antenna Factor (dB/m) | Cable Loss (dB) | Preamplifier Gain (dB) | Read Level (dBμV) | Emission Level (dBμV/m) | Limits (dBμV/m) | Margin (dB) | Detector |
|--------------------------|-----------------------|-----------------|------------------------|-------------------|-------------------------|-----------------|-------------|----------|
| @ 2480.000               | 32.11                 | 8.58            | 34.60                  | 86.61             | 92.70                   | ---             | ---         | Average  |
| 2483.500                 | 32.14                 | 8.58            | 34.61                  | 29.39             | 35.50                   | 54.00           | 18.50       | Average  |
| 2890.500                 | 32.85                 | 8.68            | 34.68                  | 29.95             | 36.80                   | 54.00           | 17.20       | Average  |

Remark: The “@” means fundamental frequency, it is ignored in this section.

|      |        |           |            |
|------|--------|-----------|------------|
| Mode | 8-DPSK | Frequency | TX 2402MHz |
|------|--------|-----------|------------|

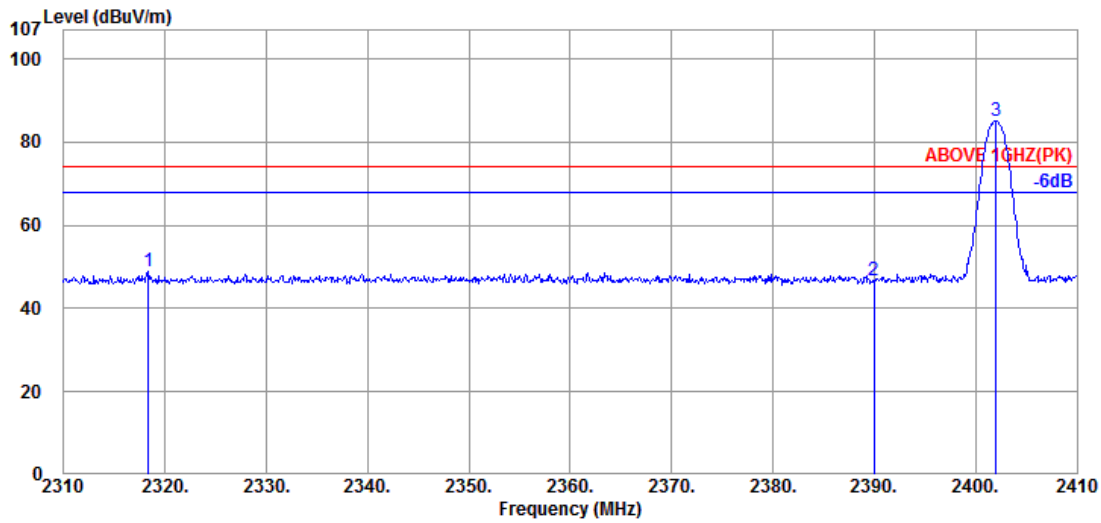

Antenna at Horizontal Polarization

| Emission Frequency (MHz) | Antenna Factor (dB/m) | Cable Loss (dB) | Preamplifier Gain (dB) | Read Level (dBμV) | Emission Level (dBμV/m) | Limits (dBμV/m) | Margin (dB) | Detector |
|--------------------------|-----------------------|-----------------|------------------------|-------------------|-------------------------|-----------------|-------------|----------|
| 2318.400                 | 31.99                 | 8.47            | 34.57                  | 42.88             | 48.77                   | 74.00           | 25.23       | Peak     |
| 2390.000                 | 32.44                 | 8.52            | 34.58                  | 40.26             | 46.64                   | 74.00           | 27.36       | Peak     |
| @ 2402.000               | 32.50                 | 8.52            | 34.59                  | 78.76             | 85.19                   | ---             | ---         | Peak     |

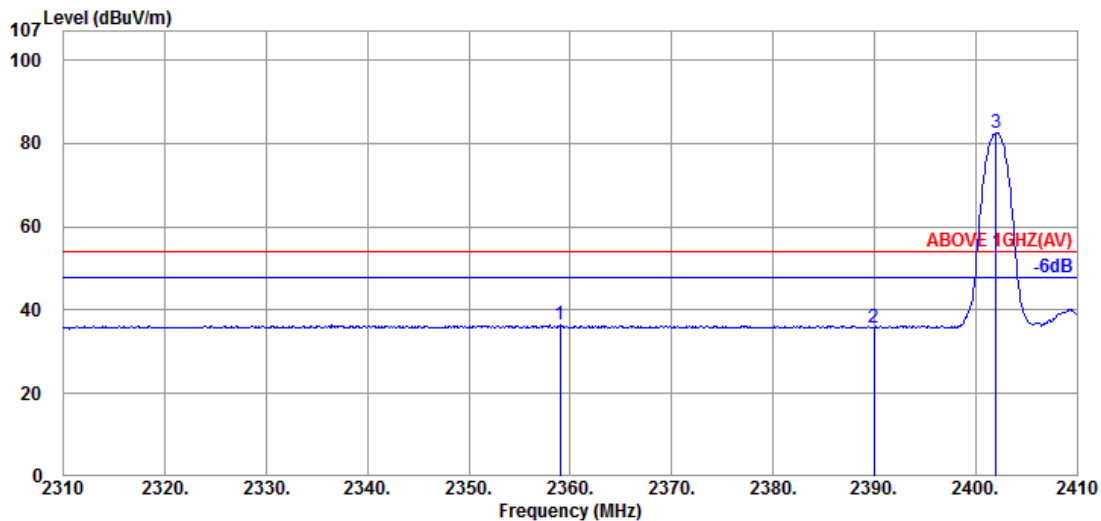

Antenna at Horizontal Polarization

| Emission Frequency (MHz) | Antenna Factor (dB/m) | Cable Loss (dB) | Preamplifier Gain (dB) | Read Level (dBμV) | Emission Level (dBμV/m) | Limits (dBμV/m) | Margin (dB) | Detector |
|--------------------------|-----------------------|-----------------|------------------------|-------------------|-------------------------|-----------------|-------------|----------|
| 2359.000                 | 32.33                 | 8.49            | 34.58                  | 30.42             | 36.66                   | 54.00           | 17.34       | Average  |
| 2390.000                 | 32.44                 | 8.52            | 34.58                  | 29.42             | 35.80                   | 54.00           | 18.20       | Average  |
| @ 2402.000               | 32.50                 | 8.52            | 34.59                  | 76.22             | 82.65                   | ---             | ---         | Average  |

Remark: The “@” means fundamental frequency, it is ignored in this section.

|      |        |           |            |
|------|--------|-----------|------------|
| Mode | 8-DPSK | Frequency | TX 2402MHz |
|------|--------|-----------|------------|

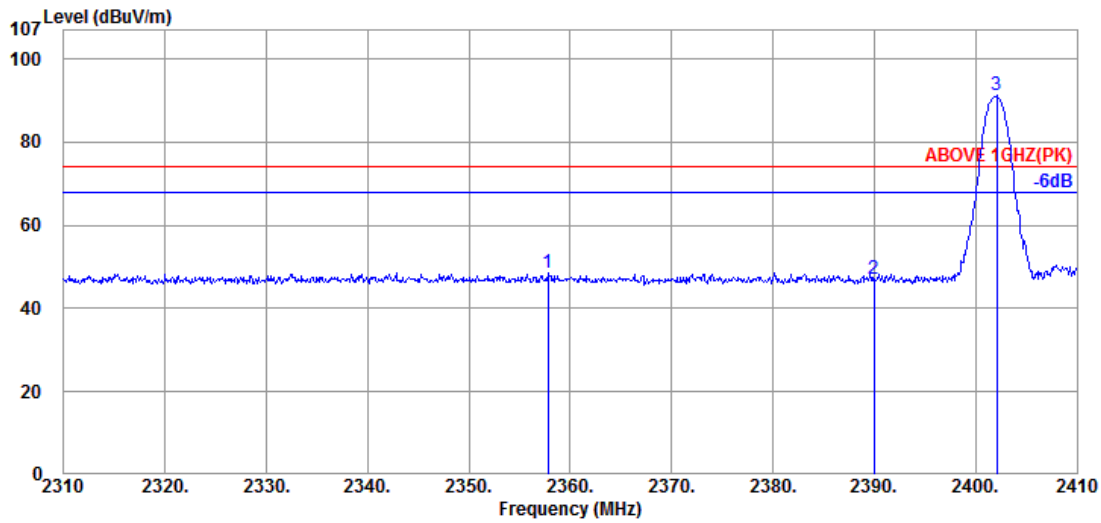

Antenna at Vertical Polarization

| Emission Frequency (MHz) | Antenna Factor (dB/m) | Cable Loss (dB) | Preamp Gain (dB) | Read Level (dBμV) | Emission Level (dBμV/m) | Limits (dBμV/m) | Margin (dB) | Detector |
|--------------------------|-----------------------|-----------------|------------------|-------------------|-------------------------|-----------------|-------------|----------|
| 2357.800                 | 32.33                 | 8.49            | 34.58            | 42.50             | 48.74                   | 74.00           | 25.26       | Peak     |
| 2390.000                 | 32.44                 | 8.52            | 34.58            | 40.74             | 47.12                   | 74.00           | 26.88       | Peak     |
| @ 2402.100               | 32.50                 | 8.52            | 34.59            | 84.69             | 91.12                   | ---             | ---         | Peak     |

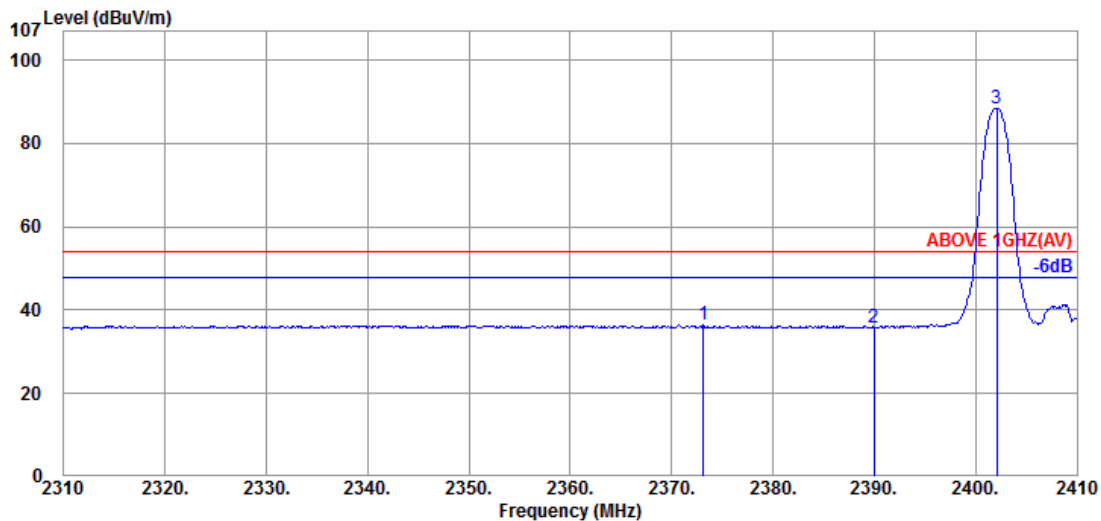

Antenna at Vertical Polarization

| Emission Frequency (MHz) | Antenna Factor (dB/m) | Cable Loss (dB) | Preamp Gain (dB) | Read Level (dBμV) | Emission Level (dBμV/m) | Limits (dBμV/m) | Margin (dB) | Detector |
|--------------------------|-----------------------|-----------------|------------------|-------------------|-------------------------|-----------------|-------------|----------|
| 2373.100                 | 32.39                 | 8.51            | 34.58            | 30.11             | 36.43                   | 54.00           | 17.57       | Average  |
| 2390.000                 | 32.44                 | 8.52            | 34.58            | 29.53             | 35.91                   | 54.00           | 18.09       | Average  |
| @ 2402.100               | 32.50                 | 8.52            | 34.59            | 82.11             | 88.54                   | ---             | ---         | Average  |

Remark: The “@” means fundamental frequency, it is ignored in this section.



|      |        |           |            |
|------|--------|-----------|------------|
| Mode | 8-DPSK | Frequency | TX 2480MHz |
|------|--------|-----------|------------|

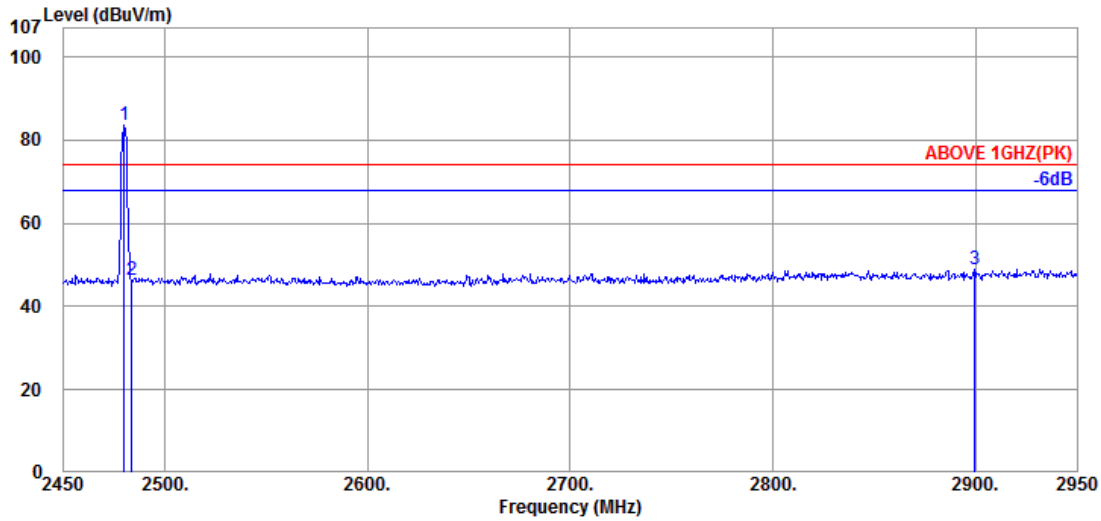

**Antenna at Horizontal Polarization**

| Emission Frequency (MHz) | Antenna Factor (dB/m) | Cable Loss (dB) | Preamplifier Gain (dB) | Read Level (dBμV) | Emission Level (dBμV/m) | Limits (dBμV/m) | Margin (dB) | Detector |
|--------------------------|-----------------------|-----------------|------------------------|-------------------|-------------------------|-----------------|-------------|----------|
| @ 2480.000               | 32.11                 | 8.58            | 34.60                  | 77.70             | 83.79                   | ---             | ---         | Peak     |
| 2483.500                 | 32.14                 | 8.58            | 34.61                  | 40.26             | 46.37                   | 74.00           | 27.63       | Peak     |
| 2899.500                 | 32.80                 | 8.69            | 34.68                  | 41.95             | 48.76                   | 74.00           | 25.24       | Peak     |

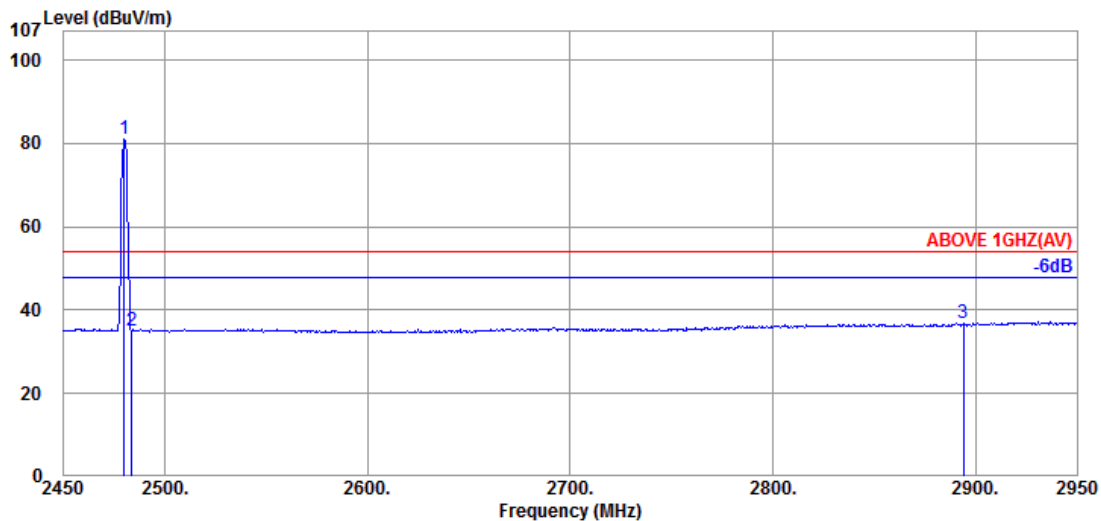

**Antenna at Horizontal Polarization**

| Emission Frequency (MHz) | Antenna Factor (dB/m) | Cable Loss (dB) | Preamplifier Gain (dB) | Read Level (dBμV) | Emission Level (dBμV/m) | Limits (dBμV/m) | Margin (dB) | Detector |
|--------------------------|-----------------------|-----------------|------------------------|-------------------|-------------------------|-----------------|-------------|----------|
| @ 2480.000               | 32.11                 | 8.58            | 34.60                  | 75.09             | 81.18                   | ---             | ---         | Average  |
| 2483.500                 | 32.14                 | 8.58            | 34.61                  | 28.93             | 35.04                   | 54.00           | 18.96       | Average  |
| 2894.000                 | 32.80                 | 8.68            | 34.68                  | 30.22             | 37.02                   | 54.00           | 16.98       | Average  |

Remark: The “@” means fundamental frequency, it is ignored in this section.

|      |        |           |            |
|------|--------|-----------|------------|
| Mode | 8-DPSK | Frequency | TX 2480MHz |
|------|--------|-----------|------------|

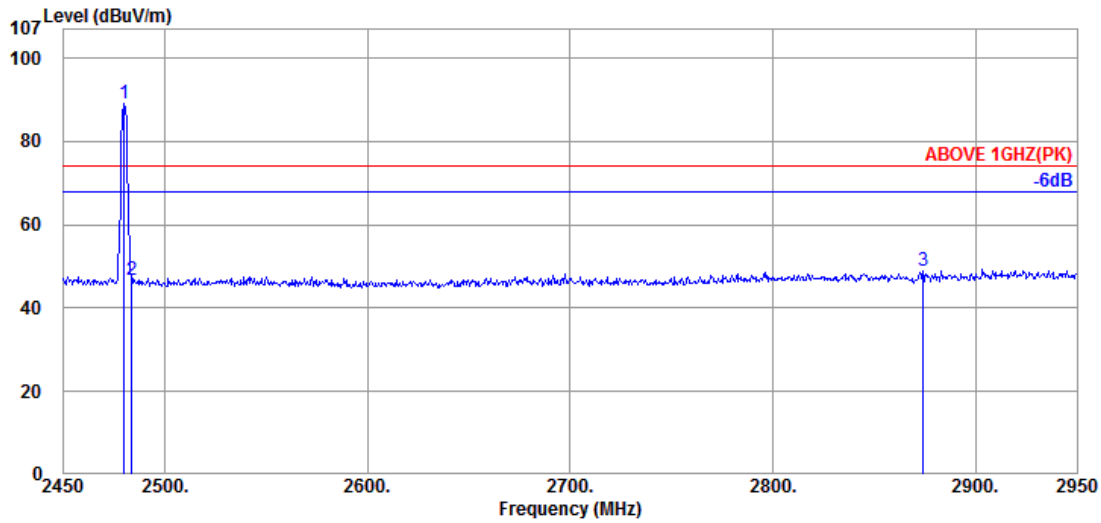

Antenna at Vertical Polarization

| Emission Frequency (MHz) | Antenna Factor (dB/m) | Cable Loss (dB) | Preamplifier Gain (dB) | Read Level (dBμV) | Emission Level (dBμV/m) | Limits (dBμV/m) | Margin (dB) | Detector |
|--------------------------|-----------------------|-----------------|------------------------|-------------------|-------------------------|-----------------|-------------|----------|
| @ 2480.000               | 32.11                 | 8.58            | 34.60                  | 83.12             | 89.21                   | ---             | ---         | Peak     |
| 2483.500                 | 32.14                 | 8.58            | 34.61                  | 40.61             | 46.72                   | 74.00           | 27.28       | Peak     |
| 2874.000                 | 32.95                 | 8.68            | 34.68                  | 42.08             | 49.03                   | 74.00           | 24.97       | Peak     |

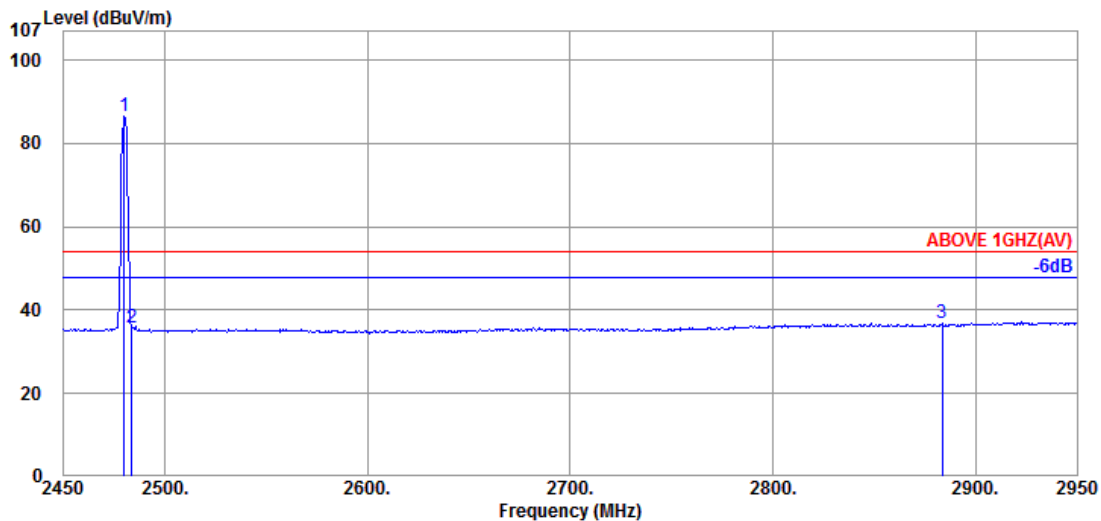

Antenna at Vertical Polarization

| Emission Frequency (MHz) | Antenna Factor (dB/m) | Cable Loss (dB) | Preamplifier Gain (dB) | Read Level (dBμV) | Emission Level (dBμV/m) | Limits (dBμV/m) | Margin (dB) | Detector |
|--------------------------|-----------------------|-----------------|------------------------|-------------------|-------------------------|-----------------|-------------|----------|
| @ 2480.000               | 32.11                 | 8.58            | 34.60                  | 80.47             | 86.56                   | ---             | ---         | Average  |
| 2483.500                 | 32.14                 | 8.58            | 34.61                  | 29.85             | 35.96                   | 54.00           | 18.04       | Average  |
| 2883.500                 | 32.90                 | 8.68            | 34.68                  | 29.92             | 36.82                   | 54.00           | 17.18       | Average  |

Remark: The “@” means fundamental frequency, it is ignored in this section.

**Test SKU: SKU #2 (with LUXSHARE-ICT Antenna)**

| Mode | GFSK | Frequency | TX 2402MHz |
|------|------|-----------|------------|
|------|------|-----------|------------|

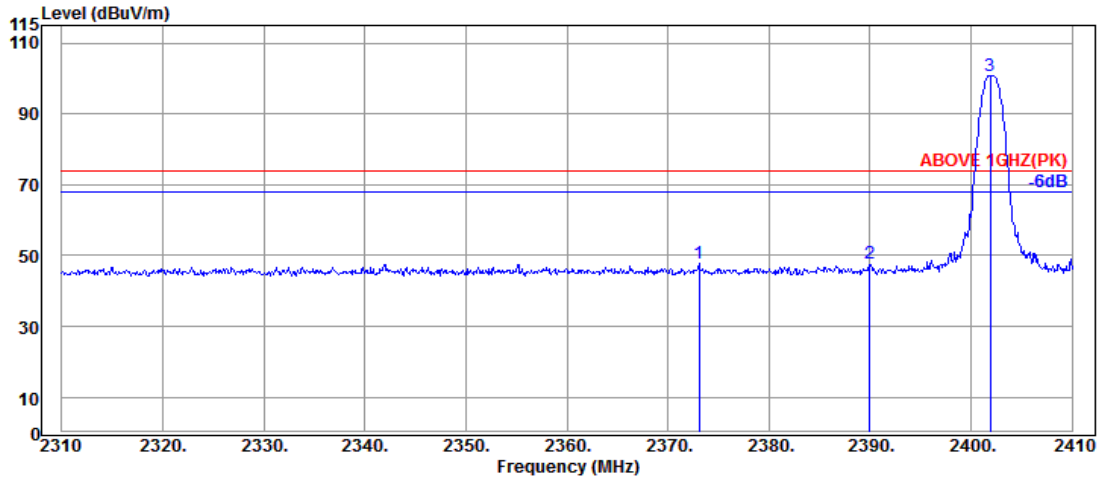

Antenna at Horizontal Polarization

| Emission Frequency (MHz) | Antenna Factor (dB/m) | Cable Loss (dB) | Preamplifier Gain (dB) | Read Level (dBμV) | Emission Level (dBμV/m) | Limits (dBμV/m) | Margin (dB) | Detector |
|--------------------------|-----------------------|-----------------|------------------------|-------------------|-------------------------|-----------------|-------------|----------|
| 2373.100                 | 28.24                 | 5.68            | 39.91                  | 53.81             | 47.82                   | 74.00           | 26.18       | Peak     |
| 2390.000                 | 28.27                 | 5.70            | 39.91                  | 53.62             | 47.68                   | 74.00           | 26.32       | Peak     |
| @ 2401.900               | 28.30                 | 5.70            | 39.91                  | 106.84            | 100.93                  | ---             | ---         | Peak     |

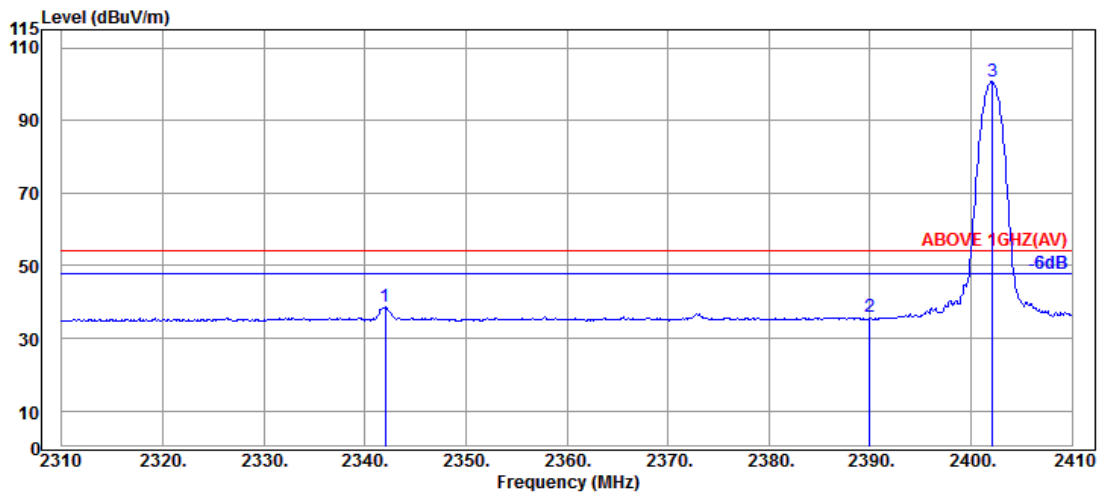

Antenna at Horizontal Polarization

| Emission Frequency (MHz) | Antenna Factor (dB/m) | Cable Loss (dB) | Preamplifier Gain (dB) | Read Level (dBμV) | Emission Level (dBμV/m) | Limits (dBμV/m) | Margin (dB) | Detector |
|--------------------------|-----------------------|-----------------|------------------------|-------------------|-------------------------|-----------------|-------------|----------|
| 2342.000                 | 28.18                 | 5.62            | 39.91                  | 44.95             | 38.84                   | 54.00           | 15.16       | Average  |
| 2390.000                 | 28.27                 | 5.70            | 39.91                  | 41.82             | 35.88                   | 54.00           | 18.12       | Average  |
| @ 2402.100               | 28.30                 | 5.70            | 39.91                  | 106.72            | 100.81                  | ---             | ---         | Average  |

Remark: The "@" means fundamental frequency, it is ignored in this section.

|      |      |           |            |
|------|------|-----------|------------|
| Mode | GFSK | Frequency | TX 2402MHz |
|------|------|-----------|------------|

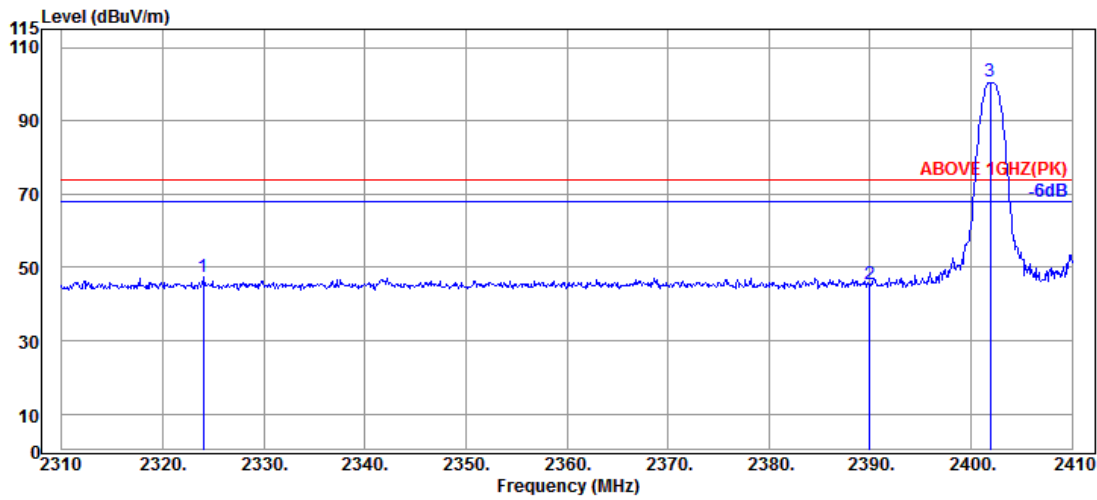

Antenna at Vertical Polarization

| Emission Frequency (MHz) | Antenna Factor (dB/m) | Cable Loss (dB) | Preamp Gain (dB) | Read Level (dBμV) | Emission Level (dBμV/m) | Limits (dBμV/m) | Margin (dB) | Detector |
|--------------------------|-----------------------|-----------------|------------------|-------------------|-------------------------|-----------------|-------------|----------|
| 2324.000                 | 28.15                 | 5.60            | 39.91            | 53.69             | 47.53                   | 74.00           | 26.47       | Peak     |
| 2390.000                 | 28.27                 | 5.70            | 39.91            | 51.54             | 45.60                   | 74.00           | 28.40       | Peak     |
| @ 2401.900               | 28.30                 | 5.70            | 39.91            | 106.55            | 100.64                  | ---             | ---         | Peak     |

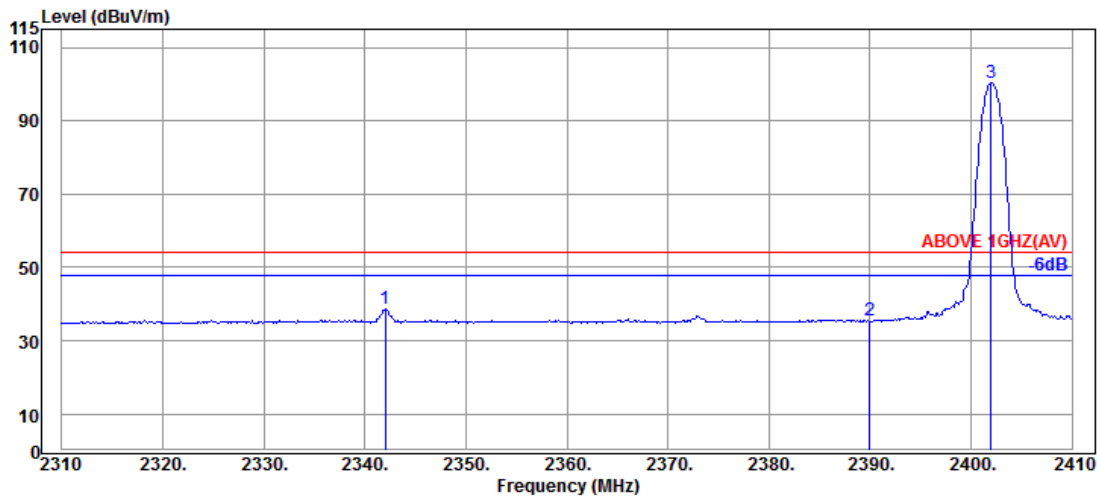

Antenna at Vertical Polarization

| Emission Frequency (MHz) | Antenna Factor (dB/m) | Cable Loss (dB) | Preamp Gain (dB) | Read Level (dBμV) | Emission Level (dBμV/m) | Limits (dBμV/m) | Margin (dB) | Detector |
|--------------------------|-----------------------|-----------------|------------------|-------------------|-------------------------|-----------------|-------------|----------|
| 2342.000                 | 28.18                 | 5.62            | 39.91            | 44.98             | 38.87                   | 54.00           | 15.13       | Average  |
| 2390.000                 | 28.27                 | 5.70            | 39.91            | 41.45             | 35.51                   | 54.00           | 18.49       | Average  |
| @ 2402.000               | 28.30                 | 5.70            | 39.91            | 106.39            | 100.48                  | ---             | ---         | Average  |

Remark: The “@” means fundamental frequency, it is ignored in this section.

|      |      |           |            |
|------|------|-----------|------------|
| Mode | GFSK | Frequency | TX 2480MHz |
|------|------|-----------|------------|

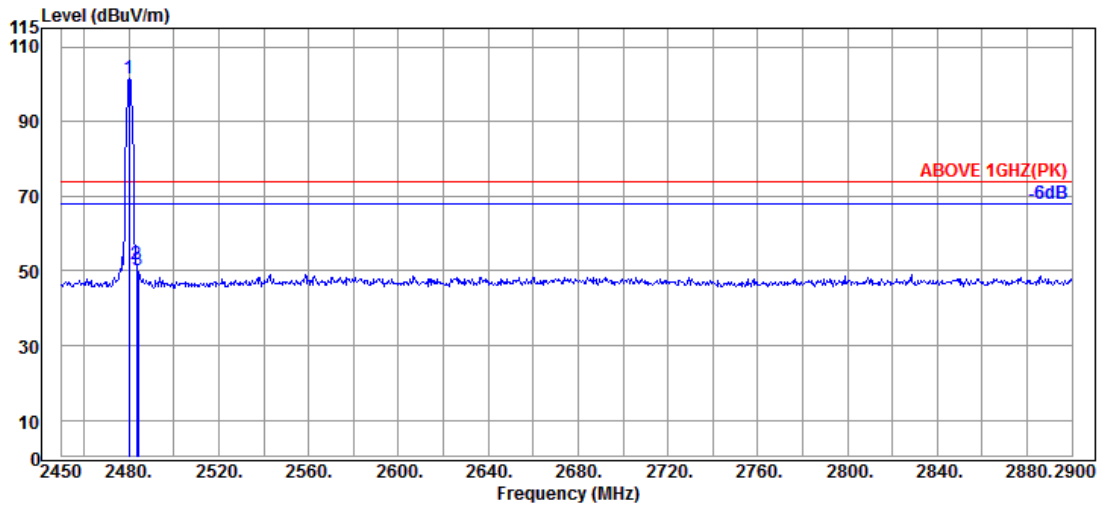

Antenna at Horizontal Polarization

| Emission Frequency (MHz) | Antenna Factor (dB/m) | Cable Loss (dB) | Preamp Gain (dB) | Read Level (dBμV) | Emission Level (dBμV/m) | Limits (dBμV/m) | Margin (dB) | Detector |
|--------------------------|-----------------------|-----------------|------------------|-------------------|-------------------------|-----------------|-------------|----------|
| @ 2480.150               | 28.60                 | 5.83            | 39.91            | 107.15            | 101.67                  | ---             | ---         | Peak     |
| 2483.300                 | 28.60                 | 5.83            | 39.91            | 57.40             | 51.92                   | 74.00           | 22.08       | Peak     |
| 2484.200                 | 28.60                 | 5.83            | 39.91            | 55.52             | 50.04                   | 74.00           | 23.96       | Peak     |

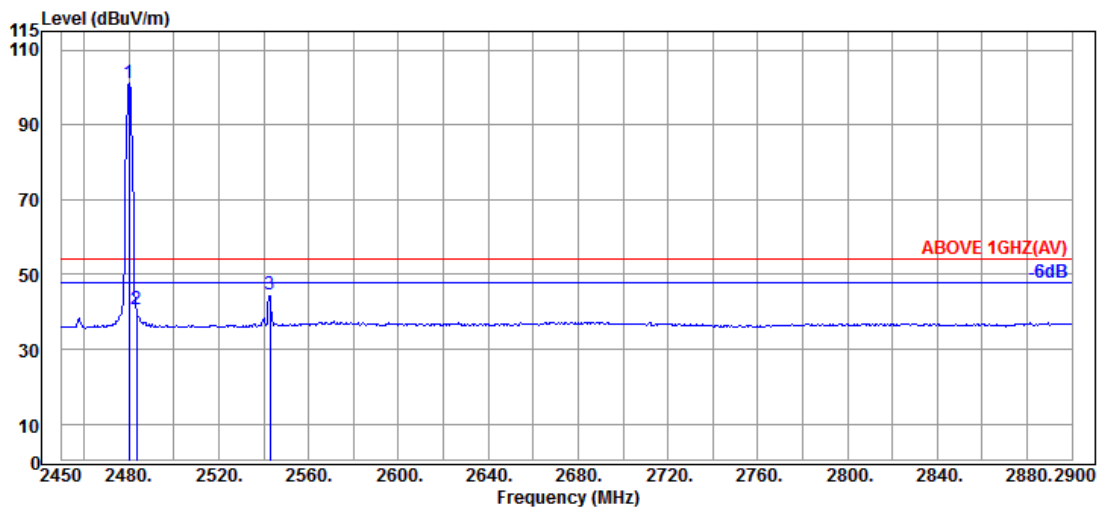

Antenna at Horizontal Polarization

| Emission Frequency (MHz) | Antenna Factor (dB/m) | Cable Loss (dB) | Preamp Gain (dB) | Read Level (dBμV) | Emission Level (dBμV/m) | Limits (dBμV/m) | Margin (dB) | Detector |
|--------------------------|-----------------------|-----------------|------------------|-------------------|-------------------------|-----------------|-------------|----------|
| @ 2480.150               | 28.60                 | 5.83            | 39.91            | 106.74            | 101.26                  | ---             | ---         | Average  |
| 2483.300                 | 28.60                 | 5.83            | 39.91            | 46.35             | 40.87                   | 54.00           | 13.13       | Average  |
| 2542.700                 | 28.69                 | 5.92            | 39.92            | 49.90             | 44.59                   | 54.00           | 9.41        | Average  |

Remark: The “@” means fundamental frequency, it is ignored in this section.

|      |      |           |            |
|------|------|-----------|------------|
| Mode | GFSK | Frequency | TX 2480MHz |
|------|------|-----------|------------|

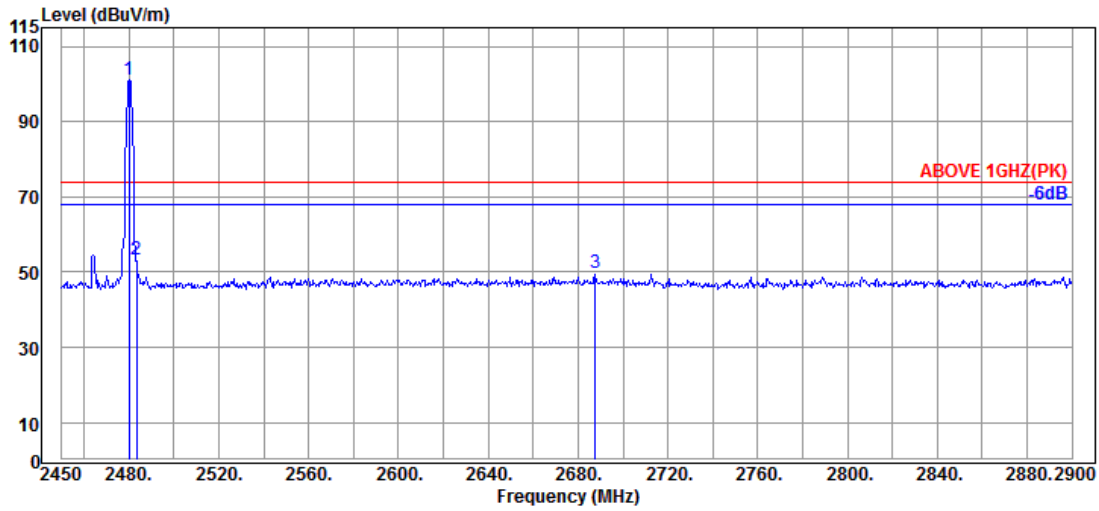

Antenna at Vertical Polarization

| Emission Frequency (MHz) | Antenna Factor (dB/m) | Cable Loss (dB) | Preamplifier Gain (dB) | Read Level (dBμV) | Emission Level (dBμV/m) | Limits (dBμV/m) | Margin (dB) | Detector |
|--------------------------|-----------------------|-----------------|------------------------|-------------------|-------------------------|-----------------|-------------|----------|
| @ 2480.150               | 28.60                 | 5.83            | 39.91                  | 106.84            | 101.36                  | ---             | ---         | Peak     |
| 2483.300                 | 28.60                 | 5.83            | 39.91                  | 58.90             | 53.42                   | 74.00           | 20.58       | Peak     |
| 2687.600                 | 29.04                 | 6.09            | 39.96                  | 54.57             | 49.74                   | 74.00           | 24.26       | Peak     |

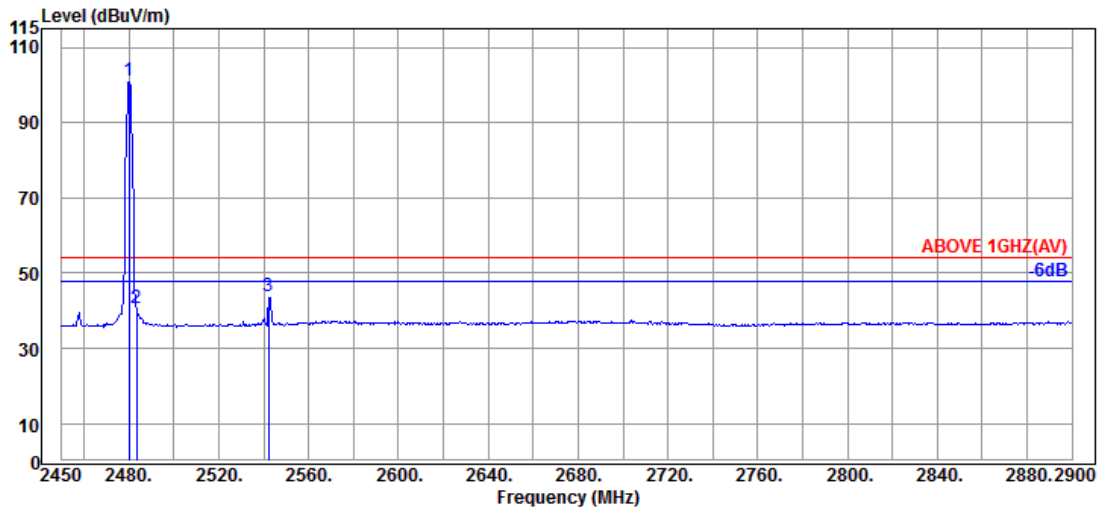

Antenna at Vertical Polarization

| Emission Frequency (MHz) | Antenna Factor (dB/m) | Cable Loss (dB) | Preamplifier Gain (dB) | Read Level (dBμV) | Emission Level (dBμV/m) | Limits (dBμV/m) | Margin (dB) | Detector |
|--------------------------|-----------------------|-----------------|------------------------|-------------------|-------------------------|-----------------|-------------|----------|
| @ 2480.150               | 28.60                 | 5.83            | 39.91                  | 106.58            | 101.10                  | ---             | ---         | Average  |
| 2483.300                 | 28.60                 | 5.83            | 39.91                  | 46.33             | 40.85                   | 54.00           | 13.15       | Average  |
| 2542.250                 | 28.69                 | 5.92            | 39.92                  | 49.12             | 43.81                   | 54.00           | 10.19       | Average  |

Remark: The "@" means fundamental frequency, it is ignored in this section.

|      |        |           |            |
|------|--------|-----------|------------|
| Mode | 8-DPSK | Frequency | TX 2402MHz |
|------|--------|-----------|------------|

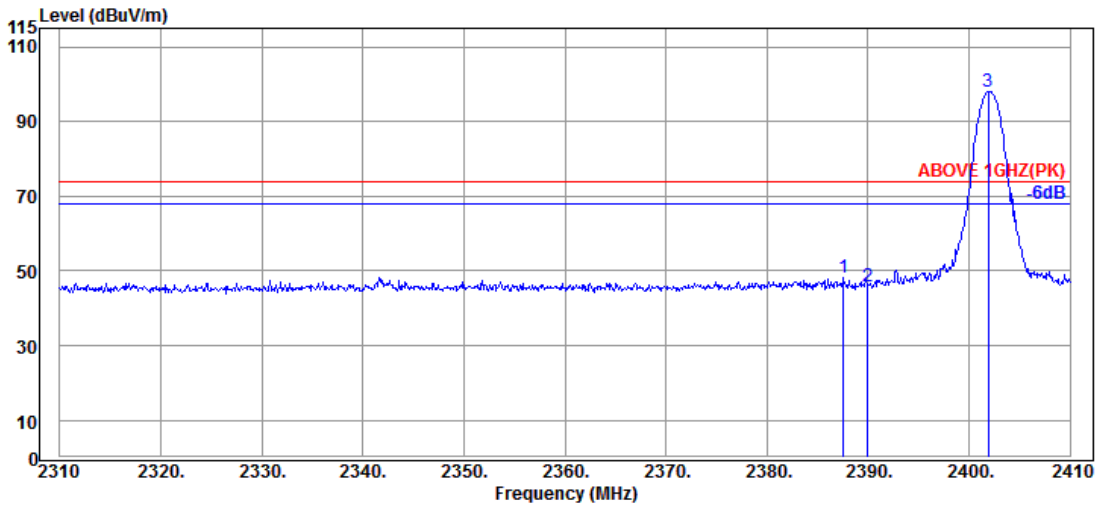

Antenna at Horizontal Polarization

| Emission Frequency (MHz) | Antenna Factor (dB/m) | Cable Loss (dB) | Preamplifier Gain (dB) | Read Level (dBμV) | Emission Level (dBμV/m) | Limits (dBμV/m) | Margin (dB) | Detector |
|--------------------------|-----------------------|-----------------|------------------------|-------------------|-------------------------|-----------------|-------------|----------|
| 2387.600                 | 28.27                 | 5.70            | 39.91                  | 54.27             | 48.33                   | 74.00           | 25.67       | Peak     |
| 2390.000                 | 28.27                 | 5.70            | 39.91                  | 51.78             | 45.84                   | 74.00           | 28.16       | Peak     |
| @ 2401.900               | 28.30                 | 5.70            | 39.91                  | 104.10            | 98.19                   | ---             | ---         | Peak     |

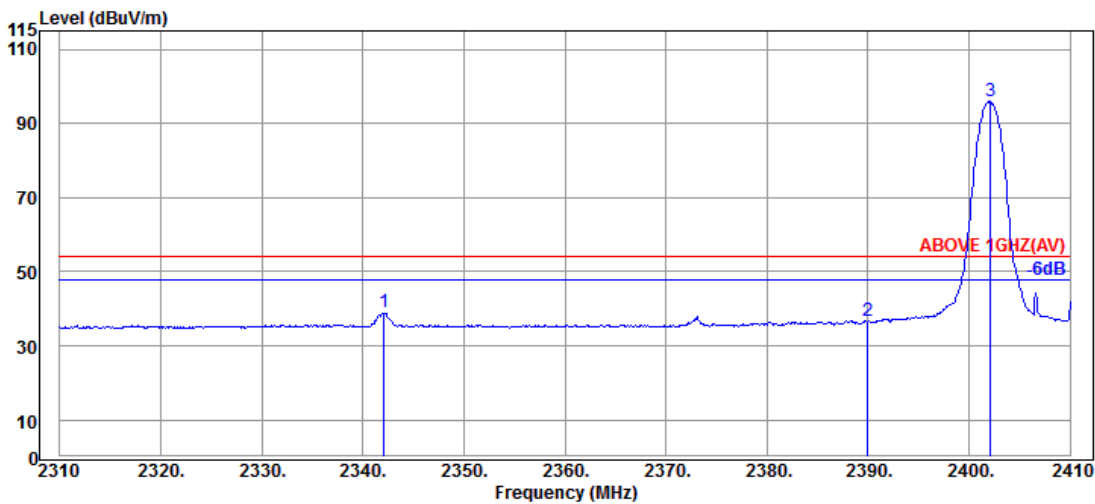

Antenna at Horizontal Polarization

| Emission Frequency (MHz) | Antenna Factor (dB/m) | Cable Loss (dB) | Preamplifier Gain (dB) | Read Level (dBμV) | Emission Level (dBμV/m) | Limits (dBμV/m) | Margin (dB) | Detector |
|--------------------------|-----------------------|-----------------|------------------------|-------------------|-------------------------|-----------------|-------------|----------|
| 2342.100                 | 28.18                 | 5.62            | 39.91                  | 45.04             | 38.93                   | 54.00           | 15.07       | Average  |
| 2390.000                 | 28.27                 | 5.70            | 39.91                  | 42.64             | 36.70                   | 54.00           | 17.30       | Average  |
| @ 2402.100               | 28.30                 | 5.70            | 39.91                  | 101.98            | 96.07                   | ---             | ---         | Average  |

Remark: The “@” means fundamental frequency, it is ignored in this section.

|      |        |           |            |
|------|--------|-----------|------------|
| Mode | 8-DPSK | Frequency | TX 2402MHz |
|------|--------|-----------|------------|

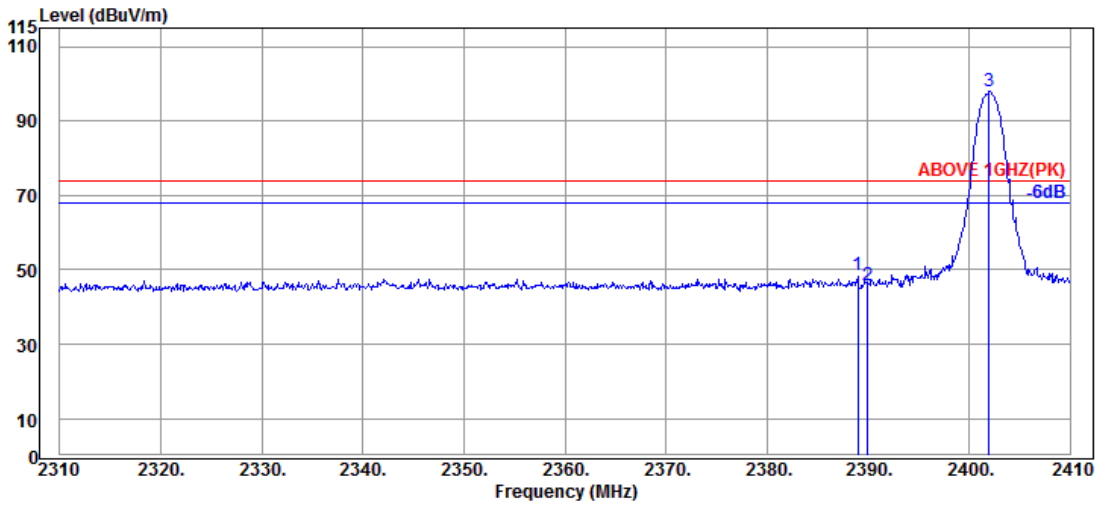

Antenna at Vertical Polarization

| Emission Frequency (MHz) | Antenna Factor (dB/m) | Cable Loss (dB) | Preamplifier Gain (dB) | Read Level (dBμV) | Emission Level (dBμV/m) | Limits (dBμV/m) | Margin (dB) | Detector |
|--------------------------|-----------------------|-----------------|------------------------|-------------------|-------------------------|-----------------|-------------|----------|
| 2389.000                 | 28.27                 | 5.70            | 39.91                  | 54.38             | 48.44                   | 74.00           | 25.56       | Peak     |
| 2390.000                 | 28.27                 | 5.70            | 39.91                  | 51.77             | 45.83                   | 74.00           | 28.17       | Peak     |
| @ 2402.000               | 28.30                 | 5.70            | 39.91                  | 104.00            | 98.09                   | ---             | ---         | Peak     |

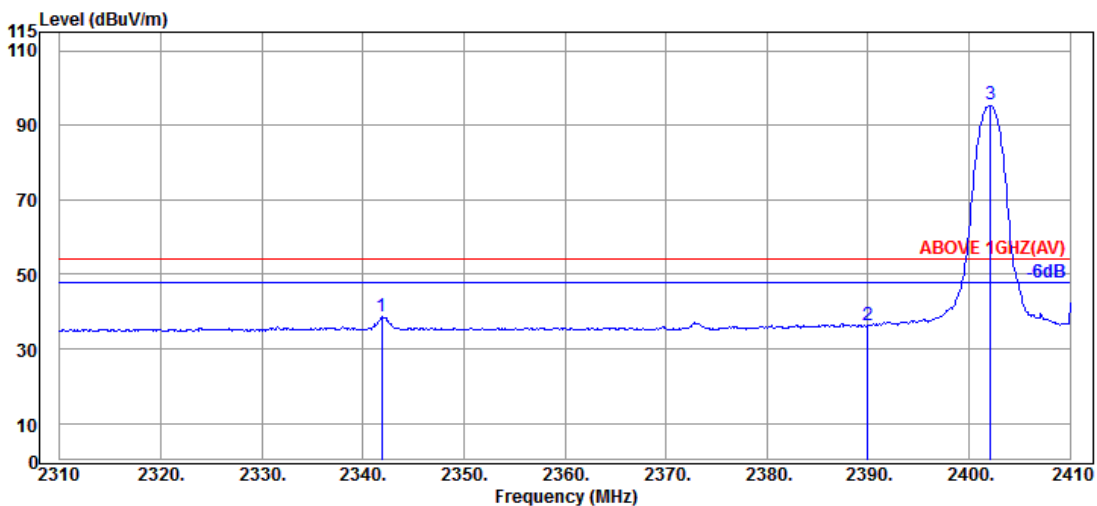

Antenna at Vertical Polarization

| Emission Frequency (MHz) | Antenna Factor (dB/m) | Cable Loss (dB) | Preamplifier Gain (dB) | Read Level (dBμV) | Emission Level (dBμV/m) | Limits (dBμV/m) | Margin (dB) | Detector |
|--------------------------|-----------------------|-----------------|------------------------|-------------------|-------------------------|-----------------|-------------|----------|
| 2341.900                 | 28.18                 | 5.62            | 39.91                  | 44.82             | 38.71                   | 54.00           | 15.29       | Average  |
| 2390.000                 | 28.27                 | 5.70            | 39.91                  | 42.46             | 36.52                   | 54.00           | 17.48       | Average  |
| @ 2402.100               | 28.30                 | 5.70            | 39.91                  | 101.49            | 95.58                   | ---             | ---         | Average  |

Remark: The “@” means fundamental frequency, it is ignored in this section.



|      |        |           |            |
|------|--------|-----------|------------|
| Mode | 8-DPSK | Frequency | TX 2480MHz |
|------|--------|-----------|------------|

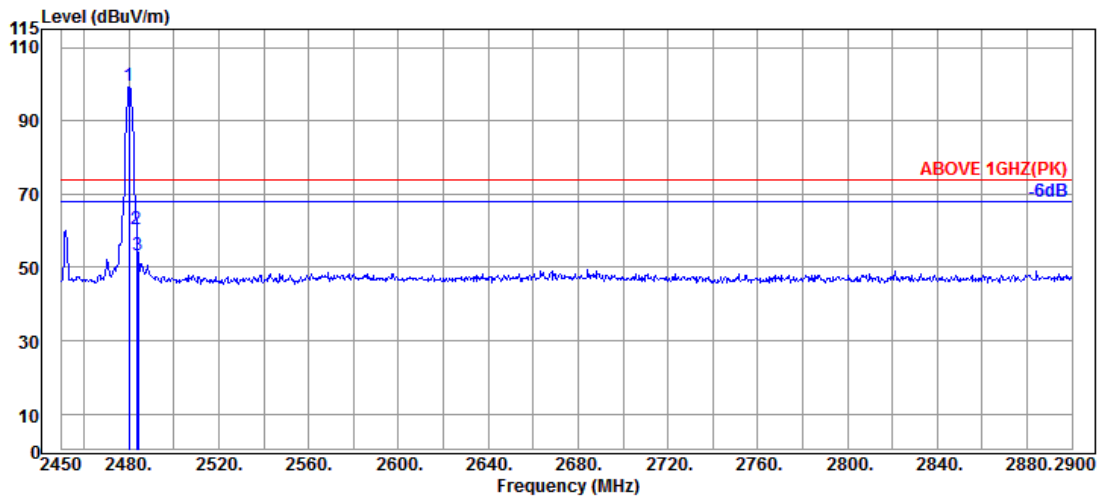

Antenna at Horizontal Polarization

| Emission Frequency (MHz) | Antenna Factor (dB/m) | Cable Loss (dB) | Preamplifier Gain (dB) | Read Level (dBμV) | Emission Level (dBμV/m) | Limits (dBμV/m) | Margin (dB) | Detector |
|--------------------------|-----------------------|-----------------|------------------------|-------------------|-------------------------|-----------------|-------------|----------|
| @ 2480.150               | 28.60                 | 5.83            | 39.91                  | 105.12            | 99.64                   | ---             | ---         | Peak     |
| 2483.300                 | 28.60                 | 5.83            | 39.91                  | 65.98             | 60.50                   | 74.00           | 13.50       | Peak     |
| 2484.200                 | 28.60                 | 5.83            | 39.91                  | 58.82             | 53.34                   | 74.00           | 20.66       | Peak     |

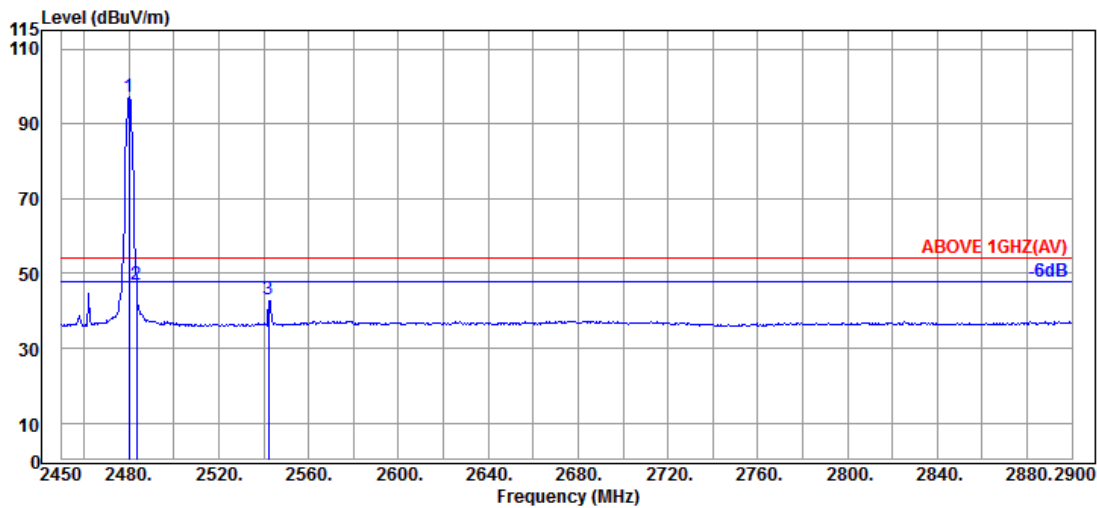

Antenna at Horizontal Polarization

| Emission Frequency (MHz) | Antenna Factor (dB/m) | Cable Loss (dB) | Meter Reading (dBμV) | Emission Level (dBμV/m) | Limits (dBμV/m) | Margin (dB) | Detector |
|--------------------------|-----------------------|-----------------|----------------------|-------------------------|-----------------|-------------|----------|
| @ 2480.150               | 28.60                 | 5.83            | 39.91                | 102.88                  | ---             | ---         | Average  |
| 2483.300                 | 28.60                 | 5.83            | 39.91                | 52.38                   | 54.00           | 1.62        | Average  |
| 2542.250                 | 28.69                 | 5.92            | 39.92                | 48.31                   | 54.00           | 5.69        | Average  |

Remark: The “@” means fundamental frequency, it is ignored in this section.

|      |        |           |            |
|------|--------|-----------|------------|
| Mode | 8-DPSK | Frequency | TX 2480MHz |
|------|--------|-----------|------------|

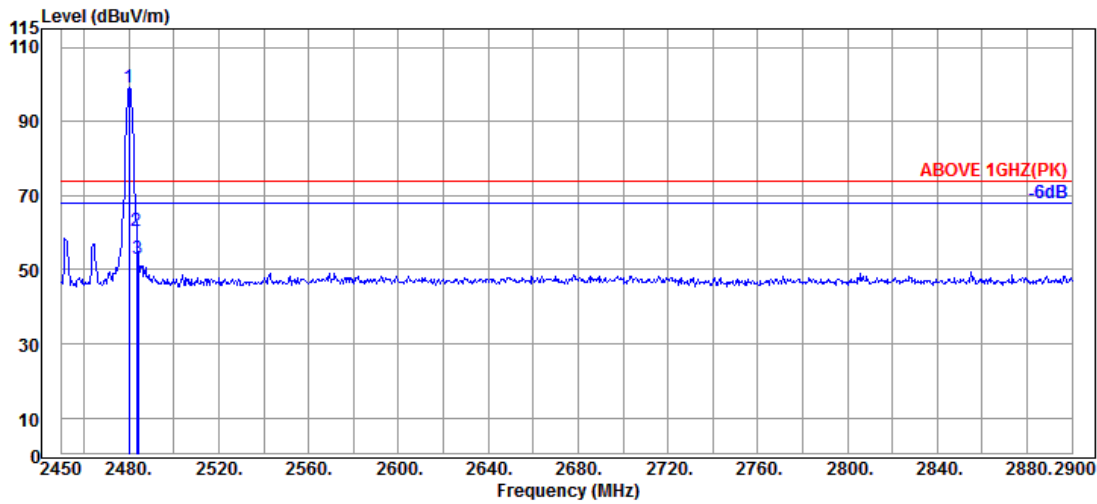

**Antenna at Vertical Polarization**

| Emission Frequency (MHz) | Antenna Factor (dB/m) | Cable Loss (dB) | Preamp Gain (dB) | Read Level (dBμV) | Emission Level (dBμV/m) | Limits (dBμV/m) | Margin (dB) | Detector |
|--------------------------|-----------------------|-----------------|------------------|-------------------|-------------------------|-----------------|-------------|----------|
| @ 2480.150               | 28.60                 | 5.83            | 39.91            | 104.87            | 99.39                   | ---             | ---         | Peak     |
| 2483.300                 | 28.60                 | 5.83            | 39.91            | 65.94             | 60.46                   | 74.00           | 13.54       | Peak     |
| 2484.200                 | 28.60                 | 5.83            | 39.91            | 58.53             | 53.05                   | 74.00           | 20.95       | Peak     |

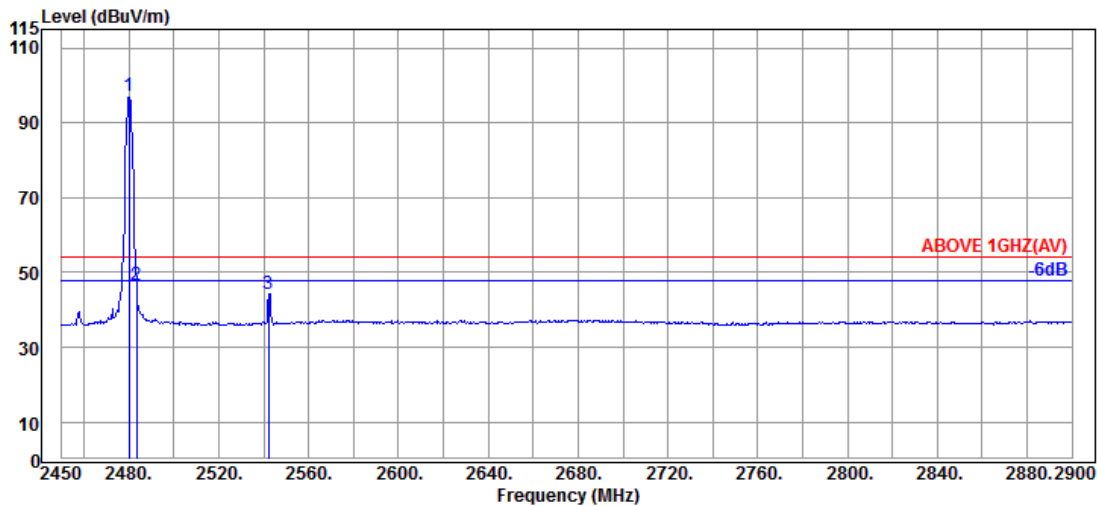

**Antenna at Vertical Polarization**

| Emission Frequency (MHz) | Antenna Factor (dB/m) | Cable Loss (dB) | Preamp Gain (dB) | Read Level (dBμV) | Emission Level (dBμV/m) | Limits (dBμV/m) | Margin (dB) | Detector |
|--------------------------|-----------------------|-----------------|------------------|-------------------|-------------------------|-----------------|-------------|----------|
| @ 2480.150               | 28.60                 | 5.83            | 39.91            | 102.64            | 97.16                   | ---             | ---         | Average  |
| 2483.300                 | 28.60                 | 5.83            | 39.91            | 52.01             | 46.53                   | 54.00           | 7.47        | Average  |
| 2542.250                 | 28.69                 | 5.92            | 39.92            | 49.74             | 44.43                   | 54.00           | 9.57        | Average  |

Remark: The “@” means fundamental frequency, it is ignored in this section.

A.2.2 Emissions outside the frequency band:

The emissions (up to 25GHz) not reported for there is no emission be found.

**Test SKU: SKU #1 (with INPAQ Antenna)**

|      |      |           |            |
|------|------|-----------|------------|
| Mode | GFSK | Frequency | TX 2402MHz |
|------|------|-----------|------------|

**Antenna at Horizontal Polarization**

| Emission Frequency (MHz) | Antenna Factor (dB/m) | Cable Loss (dB) | Preamplifier Gain (dB) | Read Level (dBμV) | Emission Level (dBμV/m) | Limits (dBμV/m) | Margin (dB) | Detector |
|--------------------------|-----------------------|-----------------|------------------------|-------------------|-------------------------|-----------------|-------------|----------|
| 4804.000                 | 34.10                 | 10.22           | 34.47                  | 31.62             | 41.47                   | 54.00           | 12.53       | Peak     |

**Antenna at Vertical Polarization**

| Emission Frequency (MHz) | Antenna Factor (dB/m) | Cable Loss (dB) | Preamplifier Gain (dB) | Read Level (dBμV) | Emission Level (dBμV/m) | Limits (dBμV/m) | Margin (dB) | Detector |
|--------------------------|-----------------------|-----------------|------------------------|-------------------|-------------------------|-----------------|-------------|----------|
| 4804.000                 | 34.10                 | 10.22           | 34.47                  | 31.08             | 40.93                   | 54.00           | 13.07       | Peak     |

|      |      |           |            |
|------|------|-----------|------------|
| Mode | GFSK | Frequency | TX 2441MHz |
|------|------|-----------|------------|

**Antenna at Horizontal Polarization**

| Emission Frequency (MHz) | Antenna Factor (dB/m) | Cable Loss (dB) | Preamplifier Gain (dB) | Read Level (dBμV) | Emission Level (dBμV/m) | Limits (dBμV/m) | Margin (dB) | Detector |
|--------------------------|-----------------------|-----------------|------------------------|-------------------|-------------------------|-----------------|-------------|----------|
| 4882.000                 | 34.03                 | 10.24           | 34.45                  | 30.95             | 40.77                   | 54.00           | 13.23       | Peak     |

**Antenna at Vertical Polarization**

| Emission Frequency (MHz) | Antenna Factor (dB/m) | Cable Loss (dB) | Preamplifier Gain (dB) | Read Level (dBμV) | Emission Level (dBμV/m) | Limits (dBμV/m) | Margin (dB) | Detector |
|--------------------------|-----------------------|-----------------|------------------------|-------------------|-------------------------|-----------------|-------------|----------|
| 4882.000                 | 34.03                 | 10.24           | 34.45                  | 30.17             | 39.99                   | 54.00           | 14.01       | Peak     |

|      |      |           |            |  |  |  |  |  |
|------|------|-----------|------------|--|--|--|--|--|
| Mode | GFSK | Frequency | TX 2480MHz |  |  |  |  |  |
|------|------|-----------|------------|--|--|--|--|--|

**Antenna at Horizontal Polarization**

| Emission Frequency (MHz) | Antenna Factor (dB/m) | Cable Loss (dB) | Preamplifier Gain (dB) | Read Level (dBμV) | Emission Level (dBμV/m) | Limits (dBμV/m) | Margin (dB) | Detector |
|--------------------------|-----------------------|-----------------|------------------------|-------------------|-------------------------|-----------------|-------------|----------|
| 4960.000                 | 34.10                 | 10.27           | 34.44                  | 30.71             | 40.64                   | 54.00           | 13.36       | Peak     |

**Antenna at Vertical Polarization**

| Emission Frequency (MHz) | Antenna Factor (dB/m) | Cable Loss (dB) | Preamplifier Gain (dB) | Read Level (dBμV) | Emission Level (dBμV/m) | Limits (dBμV/m) | Margin (dB) | Detector |
|--------------------------|-----------------------|-----------------|------------------------|-------------------|-------------------------|-----------------|-------------|----------|
| 4960.000                 | 34.10                 | 10.27           | 34.44                  | 30.78             | 40.71                   | 54.00           | 13.29       | Peak     |

**Test SKU: SKU #2 (with LUXSHARE-ICT Antenna)**

|      |      |           |            |  |  |  |  |  |
|------|------|-----------|------------|--|--|--|--|--|
| Mode | GFSK | Frequency | TX 2402MHz |  |  |  |  |  |
|------|------|-----------|------------|--|--|--|--|--|

**Antenna at Horizontal Polarization**

| Emission Frequency (MHz) | Antenna Factor (dB/m) | Cable Loss (dB) | Preamplifier Gain (dB) | Read Level (dBμV) | Emission Level (dBμV/m) | Limits (dBμV/m) | Margin (dB) | Detector |
|--------------------------|-----------------------|-----------------|------------------------|-------------------|-------------------------|-----------------|-------------|----------|
| 4804.000                 | 33.40                 | 8.17            | 39.33                  | 43.66             | 45.90                   | 54.00           | 8.10        | Peak     |

**Antenna at Vertical Polarization**

| Emission Frequency (MHz) | Antenna Factor (dB/m) | Cable Loss (dB) | Preamplifier Gain (dB) | Read Level (dBμV) | Emission Level (dBμV/m) | Limits (dBμV/m) | Margin (dB) | Detector |
|--------------------------|-----------------------|-----------------|------------------------|-------------------|-------------------------|-----------------|-------------|----------|
| 4804.000                 | 33.40                 | 8.17            | 39.33                  | 43.06             | 45.30                   | 54.00           | 8.70        | Peak     |

|      |      |           |            |  |  |  |  |  |
|------|------|-----------|------------|--|--|--|--|--|
| Mode | GFSK | Frequency | TX 2441MHz |  |  |  |  |  |
|------|------|-----------|------------|--|--|--|--|--|

**Antenna at Horizontal Polarization**

| Emission Frequency (MHz) | Antenna Factor (dB/m) | Cable Loss (dB) | Preamplifier Gain (dB) | Read Level (dBμV) | Emission Level (dBμV/m) | Limits (dBμV/m) | Margin (dB) | Detector |
|--------------------------|-----------------------|-----------------|------------------------|-------------------|-------------------------|-----------------|-------------|----------|
| 4882.000                 | 33.52                 | 8.20            | 39.29                  | 42.45             | 44.88                   | 54.00           | 9.12        | Peak     |

**Antenna at Vertical Polarization**

| Emission Frequency (MHz) | Antenna Factor (dB/m) | Cable Loss (dB) | Preamplifier Gain (dB) | Read Level (dBμV) | Emission Level (dBμV/m) | Limits (dBμV/m) | Margin (dB) | Detector |
|--------------------------|-----------------------|-----------------|------------------------|-------------------|-------------------------|-----------------|-------------|----------|
| 4882.000                 | 33.52                 | 8.20            | 39.29                  | 43.54             | 45.97                   | 54.00           | 8.03        | Peak     |

|      |      |           |            |
|------|------|-----------|------------|
| Mode | GFSK | Frequency | TX 2480MHz |
|------|------|-----------|------------|

**Antenna at Horizontal Polarization**

| Emission Frequency (MHz) | Antenna Factor (dB/m) | Cable Loss (dB) | Preamplifier Gain (dB) | Read Level (dB $\mu$ V) | Emission Level (dB $\mu$ V/m) | Limits (dB $\mu$ V/m) | Margin (dB) | Detector |
|--------------------------|-----------------------|-----------------|------------------------|-------------------------|-------------------------------|-----------------------|-------------|----------|
| 4960.000                 | 33.72                 | 8.24            | 39.25                  | 43.35                   | 46.06                         | 54.00                 | 7.94        | Peak     |

**Antenna at Vertical Polarization**

| Emission Frequency (MHz) | Antenna Factor (dB/m) | Cable Loss (dB) | Preamplifier Gain (dB) | Read Level (dB $\mu$ V) | Emission Level (dB $\mu$ V/m) | Limits (dB $\mu$ V/m) | Margin (dB) | Detector |
|--------------------------|-----------------------|-----------------|------------------------|-------------------------|-------------------------------|-----------------------|-------------|----------|
| 4960.000                 | 33.72                 | 8.24            | 39.25                  | 43.73                   | 46.44                         | 54.00                 | 7.56        | Peak     |

**A.2.3 Emissions in Non-restricted Frequency Bands:**

All emission levels below the FCC 15.209(a)/RSS-Gen Section 8.9 table 4 general radiated emissions limits is not required.

## A.3 20dB BANDWIDTH

|              |                               |            |             |
|--------------|-------------------------------|------------|-------------|
| Test Date    | 2019/09/18                    | Temp./Hum. | 25°C/51%    |
| Cable Loss   | 0.50dB                        | Tested By  | Martin Chen |
| Test Voltage | AC 120V 60Hz (Via AC Adapter) |            |             |

### A.3.1 20dB Bandwidth Result

| Mode   | Centre Frequency (MHz) | 20dB Bandwidth (MHz) | 99% Occupied Bandwidth (MHz) (Reference only) | 2/3 (20dB Bandwidth) |
|--------|------------------------|----------------------|---|----------------------|
| GFSK   | 2402                   | 0.9217               | 0.86410                                       | 0.614                |
|        | 2441                   | 0.9232               | 0.86892                                       | 0.615                |
|        | 2480                   | 0.9220               | 0.86466                                       | 0.615                |
| 8-DPSK | 2402                   | 1.386                | 1.3581  | 0.924                |
|        | 2441                   | 1.386                | 1.3566  | 0.924                |
|        | 2480                   | 1.389                | 1.3547  | 0.926                |

Remark: The maximum two-thirds of the 20dB bandwidth is the limit for carrier frequency separation presented.

**A.3.2 Measurement Plots**

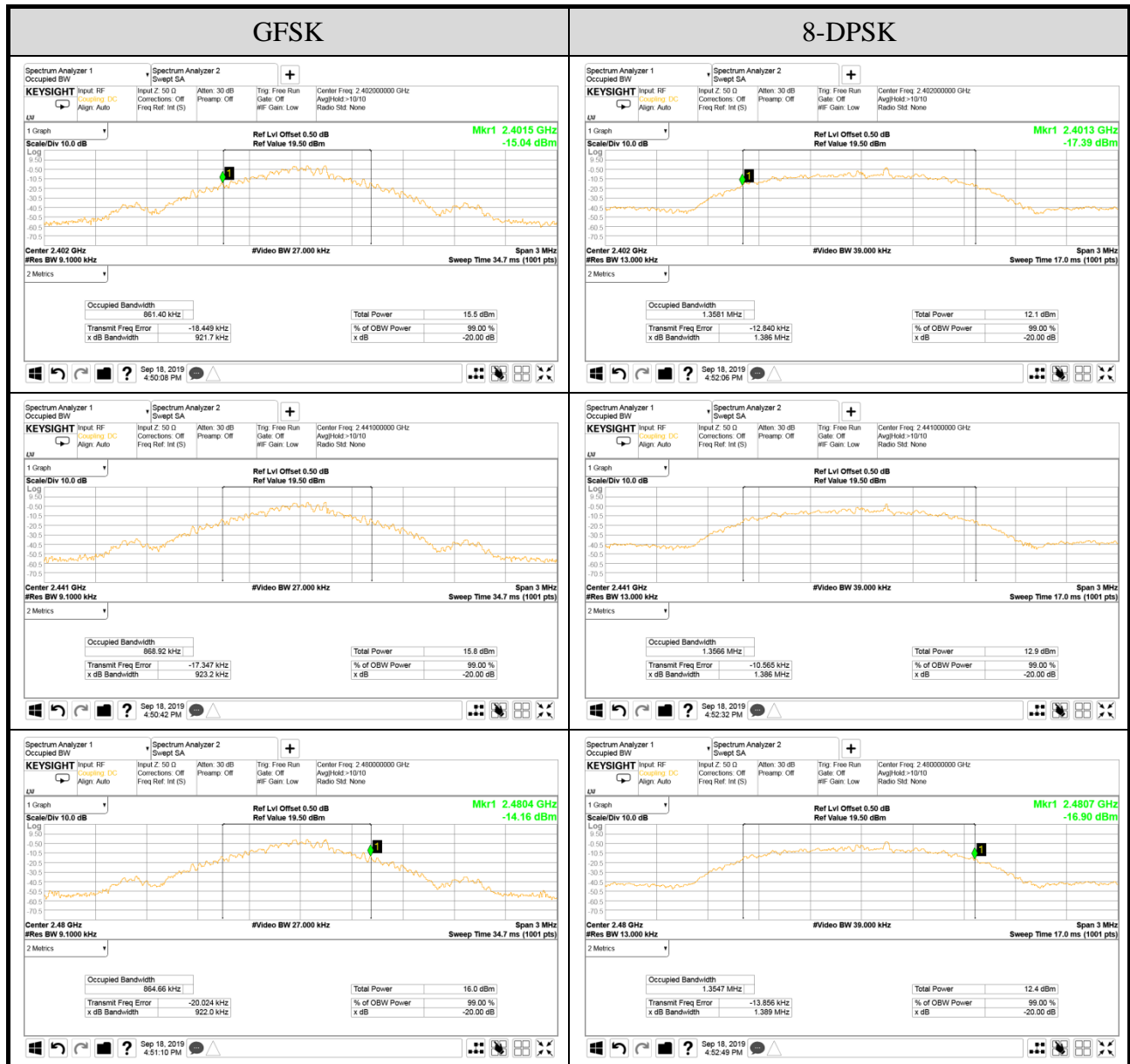

## A.4 CARRIER FREQUENCY SEPARATION

|              |                               |            |             |
|--------------|-------------------------------|------------|-------------|
| Test Date    | 2019/09/19                    | Temp./Hum. | 25°C/54%    |
| Cable Loss   | 0.50dB                        | Tested By  | Martin Chen |
| Test Voltage | AC 120V 60Hz (Via AC Adapter) |            |             |

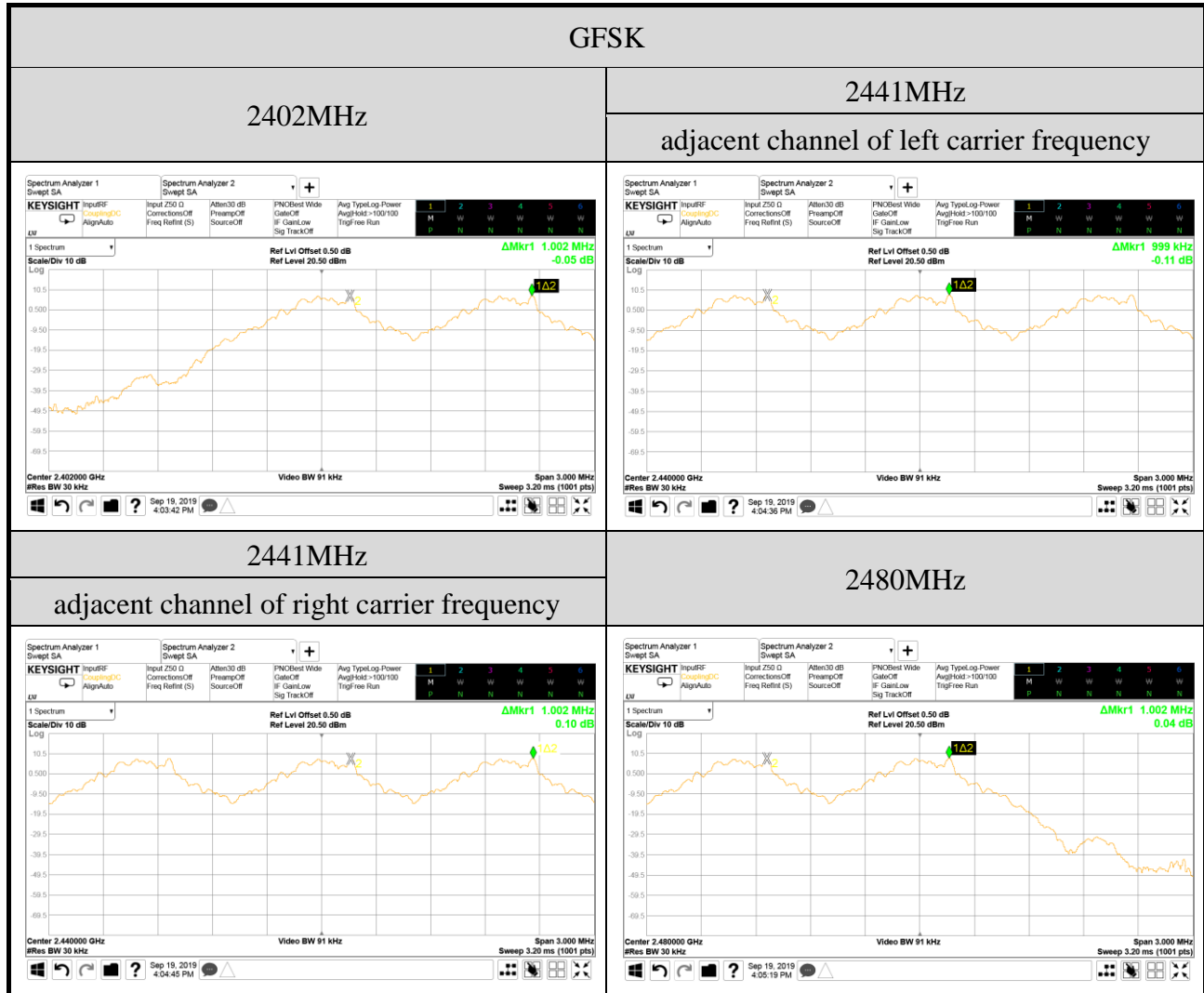



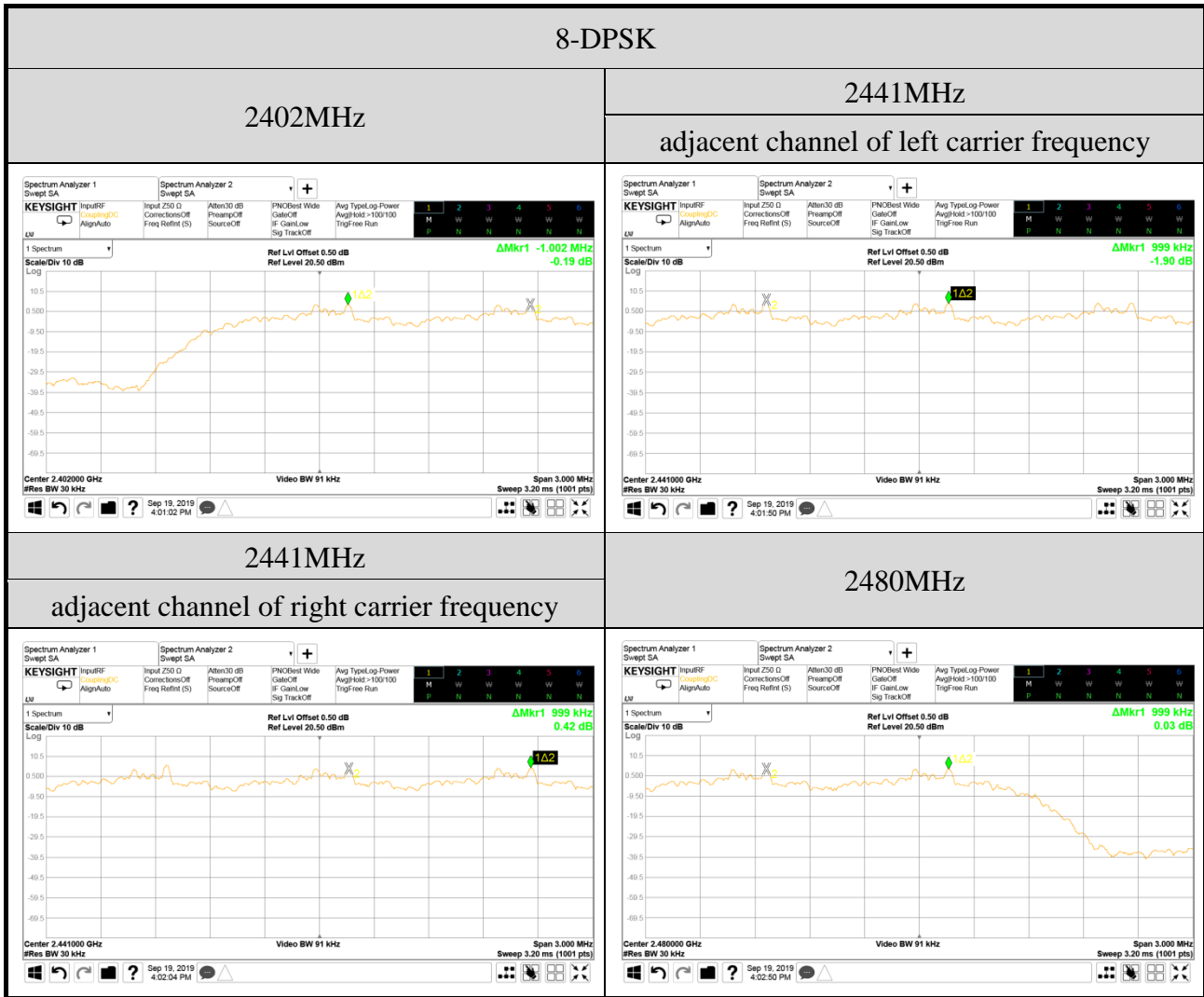

## A.5 TIME OF OCCUPANCY

|              |                               |            |             |
|--------------|-------------------------------|------------|-------------|
| Test Date    | 2019/09/19                    | Temp./Hum. | 25°C/54%    |
| Cable Loss   | 0.50dB                        | Tested By  | Martin Chen |
| Test Voltage | AC 120V 60Hz (Via AC Adapter) |            |             |

### A.5.1 Time of Occupancy

| Mode | Centre Frequency (MHz) | Mode | Each second appearance transmission | Time of Occupancy (ms) | Maximum accumulated Time of Occupancy (ms) | Limit (ms) |
|------|------------------------|------|-------------------------------------|------------------------|--|------------|
| GFSK | 2402                   | DH1  | 10                                  | 0.380                  | 120.080                                    | <400       |
|      |                        | DH3  | 5                                   | 1.635                  | 258.330                                    | <400       |
|      |                        | DH5  | 3                                   | 2.880                  | 273.024                                    | <400       |

Observation Period:

$$79 \text{ channels} * 0.4 \text{ seconds} = 31.6 \text{ seconds}$$

#### DH1 Mode

For each second of 10 transmission appearance, the longest time of occupancy is  
 $10 \text{ transmission} * 31.6 \text{ seconds} * 0.380 \text{ ms} = 120.080 \text{ ms} (<400\text{ms})$

#### DH3 Mode

For each second of 5 transmission appearance, the longest time of occupancy is  
 $5 \text{ transmission} * 31.6 \text{ seconds} * 1.635 \text{ ms} = 258.330 \text{ ms} (<400\text{ms})$

#### DH5 Mode

For each second of 3 transmission appearance, the longest time of occupancy is  
 $3 \text{ transmission} * 31.6 \text{ seconds} * 2.880 \text{ ms} = 273.024 \text{ ms} (<400\text{ms})$

| Mode | Centre Frequency (MHz) | Mode | Each second appearance transmission | Time of Occupancy (ms) | Maximum accumulated Time of Occupancy (ms) | Limit (ms) |
|------|------------------------|------|-------------------------------------|------------------------|--|------------|
| GFSK | 2440                   | DH1  | 10                                  | 0.380                  | 120.080                                    | <400       |
|      |                        | DH3  | 5                                   | 1.635                  | 258.330                                    | <400       |
|      |                        | DH5  | 3                                   | 2.880                  | 273.024                                    | <400       |

Observation Period:

$$79 \text{ channels} * 0.4 \text{ seconds} = 31.6 \text{ seconds}$$

#### DH1 Mode

For each second of 10 transmission appearance, the longest time of occupancy is  
 $10 \text{ transmission} * 31.6 \text{ seconds} * 0.380 \text{ ms} = 120.080 \text{ ms} (<400\text{ms})$

#### DH3 Mode

For each second of 5 transmission appearance, the longest time of occupancy is  
 $5 \text{ transmission} * 31.6 \text{ seconds} * 1.635 \text{ ms} = 258.330 \text{ ms} (<400\text{ms})$

#### DH5 Mode

For each second of 3 transmission appearance, the longest time of occupancy is  
 $3 \text{ transmission} * 31.6 \text{ seconds} * 2.880 \text{ ms} = 273.024 \text{ ms} (<400\text{ms})$

| Mode | Centre Frequency (MHz) | Mode | Each second appearance transmission | Time of Occupancy (ms) | Maximum accumulated Time of Occupancy (ms) | Limit (ms) |
|------|------------------------|------|-------------------------------------|------------------------|--|------------|
| GFSK | 2480                   | DH1  | 10                                  | 0.380                  | 120.080                                    | <400       |
|      |                        | DH3  | 5                                   | 1.635                  | 258.330                                    | <400       |
|      |                        | DH5  | 3                                   | 2.880                  | 273.024                                    | <400       |

Observation Period:

$79 \text{ channels} * 0.4 \text{ seconds} = 31.6 \text{ seconds}$

**DH1 Mode**

For each second of **10** transmission appearance, the longest time of occupancy is  
 $10 \text{ transmission} * 31.6 \text{ seconds} * 0.380 \text{ ms} = 120.080 \text{ ms} (<400\text{ms})$

**DH3 Mode**

For each second of **5** transmission appearance, the longest time of occupancy is  
 $5 \text{ transmission} * 31.6 \text{ seconds} * 1.635 \text{ ms} = 258.330 \text{ ms} (<400\text{ms})$

**DH5 Mode**

For each second of **3** transmission appearance, the longest time of occupancy is  
 $3 \text{ transmission} * 31.6 \text{ seconds} * 2.880 \text{ ms} = 273.024 \text{ ms} (<400\text{ms})$

● Measurement Plots

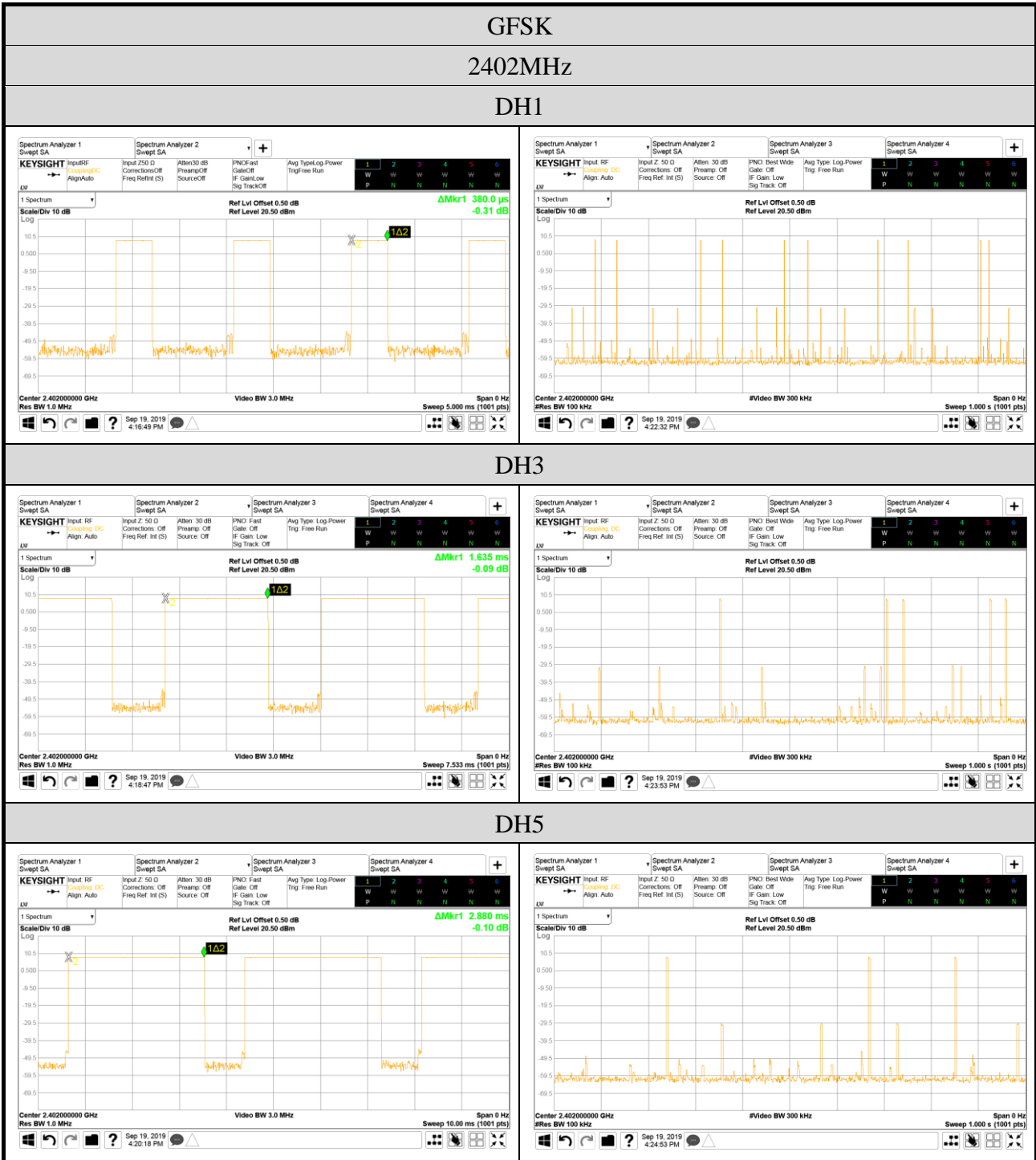

**GFSK**  
**2441MHz**

**DH1**

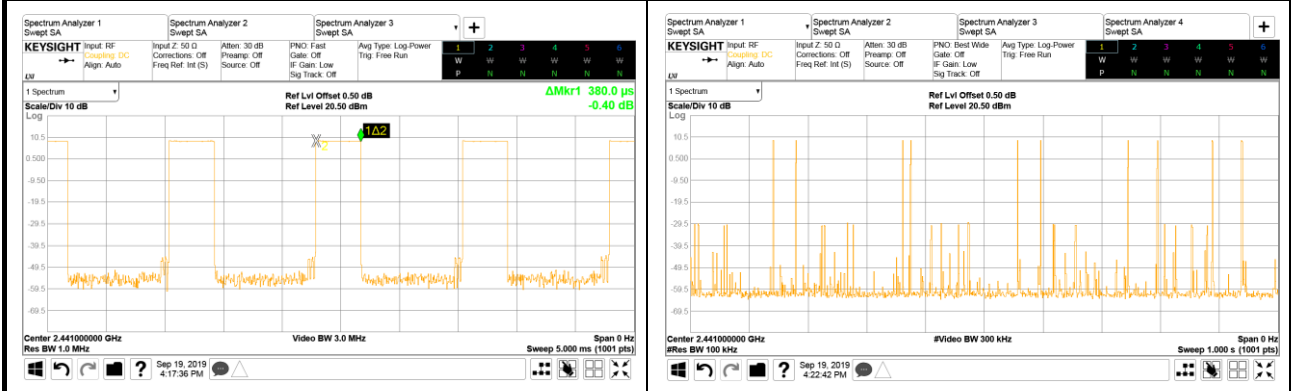

**DH3**

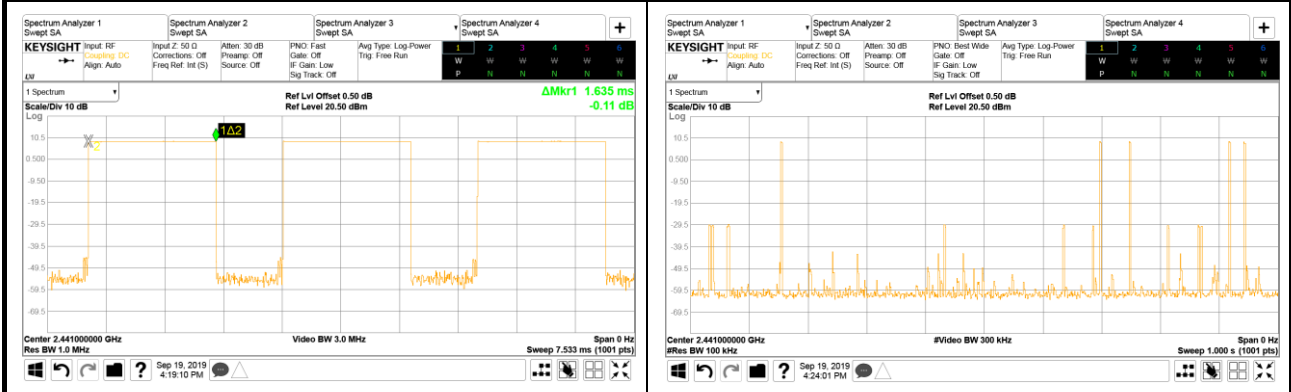

**DH5**

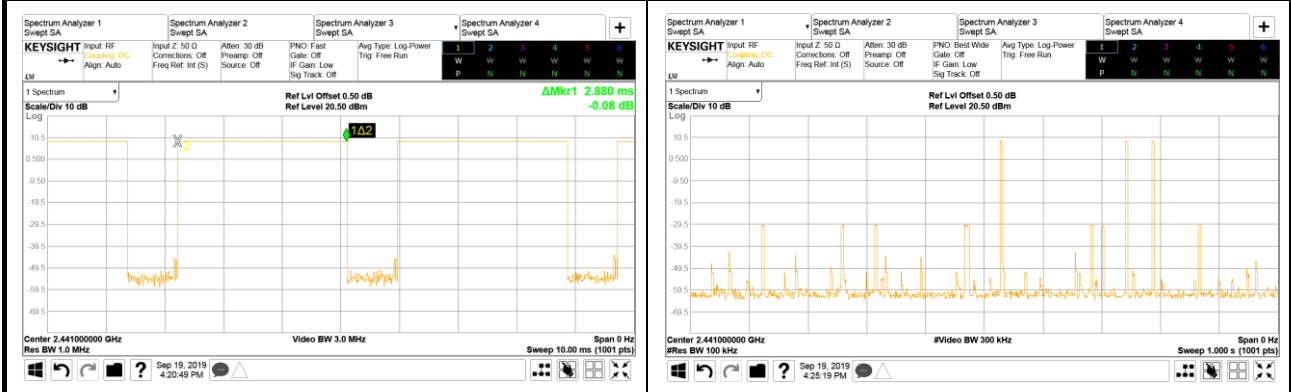

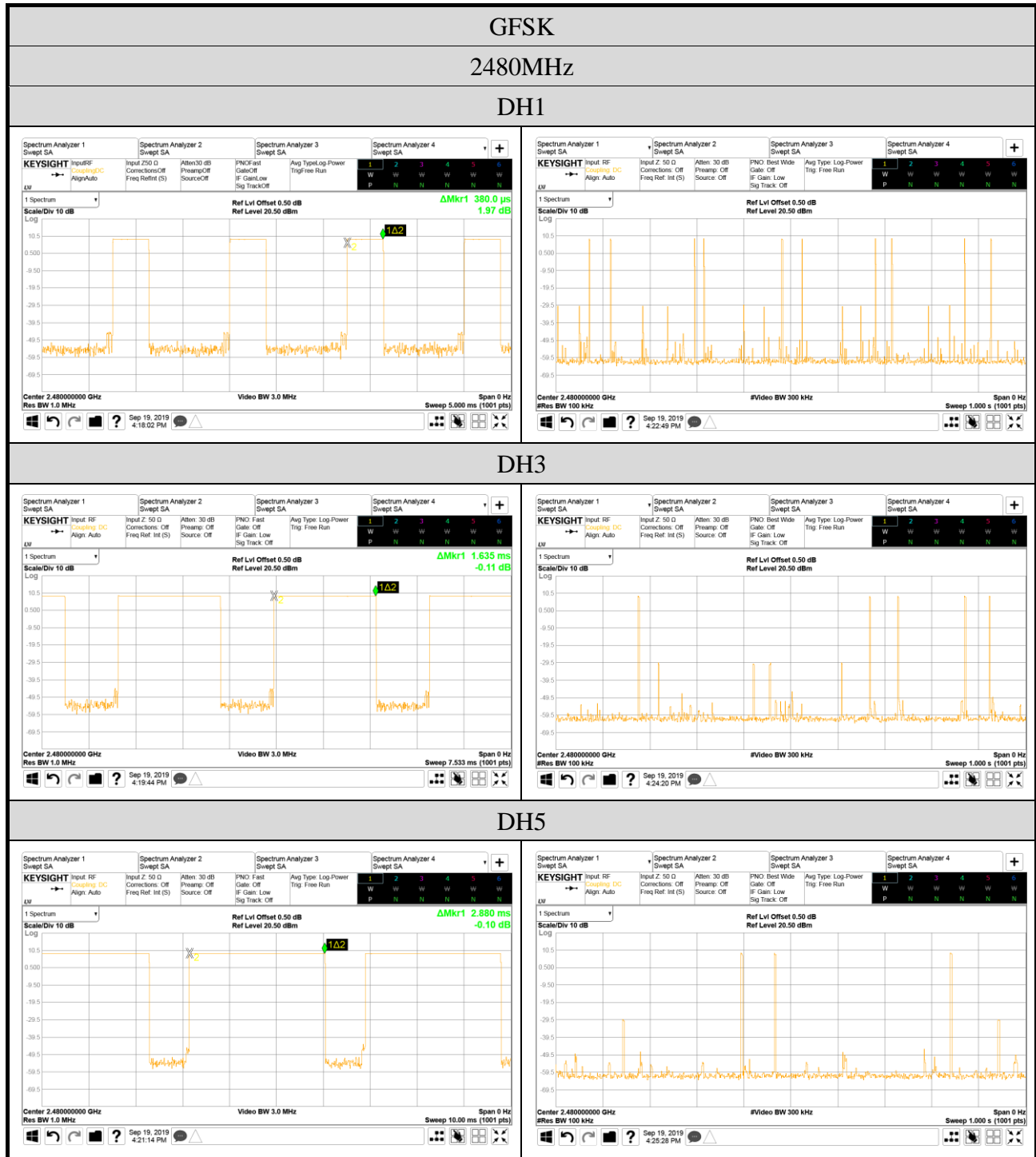

| Mode   | Centre Frequency (MHz) | Mode | Each second appearance transmission | Time of Occupancy (ms) | Maximum accumulated Time of Occupancy (ms) | Limit (ms) |
|--------|------------------------|------|-------------------------------------|------------------------|--|------------|
| 8-DPSK | 2402                   | 3DH1 | 10                                  | 0.390                  | 123.240                                    | <400       |
|        |                        | 3DH3 | 5                                   | 1.635                  | 258.330                                    | <400       |
|        |                        | 3DH5 | 3                                   | 2.890                  | 273.972                                    | <400       |

Observation Period:

$79 \text{ channels} * 0.4 \text{ seconds} = 31.6 \text{ seconds}$

**3DH1 Mode**

For each second of **10** transmission appearance, the longest time of occupancy is  
 $10 \text{ transmission} * 31.6 \text{ seconds} * 0.390 \text{ ms} = 123.240 \text{ ms} (<400\text{ms})$

**3DH3 Mode**

For each second of **5** transmission appearance, the longest time of occupancy is  
 $5 \text{ transmission} * 31.6 \text{ seconds} * 1.635 \text{ ms} = 258.330 \text{ ms} (<400\text{ms})$

**3DH5 Mode**

For each second of **3** transmission appearance, the longest time of occupancy is  
 $3 \text{ transmission} * 31.6 \text{ seconds} * 2.890 \text{ ms} = 273.972 \text{ ms} (<400\text{ms})$

| Mode   | Centre Frequency (MHz) | Mode | Each second appearance transmission | Time of Occupancy (ms) | Maximum accumulated Time of Occupancy (ms) | Limit (ms) |
|--------|------------------------|------|-------------------------------------|------------------------|--|------------|
| 8-DPSK | 2441                   | 3DH1 | 10                                  | 0.390                  | 123.240                                    | <400       |
|        |                        | 3DH3 | 5                                   | 1.635                  | 258.330                                    | <400       |
|        |                        | 3DH5 | 3                                   | 2.890                  | 273.972                                    | <400       |

Observation Period:

$79 \text{ channels} * 0.4 \text{ seconds} = 31.6 \text{ seconds}$

**3DH1 Mode**

For each second of **10** transmission appearance, the longest time of occupancy is  
 $10 \text{ transmission} * 31.6 \text{ seconds} * 0.390 \text{ ms} = 123.240 \text{ ms} (<400\text{ms})$

**3DH3 Mode**

For each second of **5** transmission appearance, the longest time of occupancy is  
 $5 \text{ transmission} * 31.6 \text{ seconds} * 1.635 \text{ ms} = 258.330 \text{ ms} (<400\text{ms})$

**3DH5 Mode**

For each second of **3** transmission appearance, the longest time of occupancy is  
 $3 \text{ transmission} * 31.6 \text{ seconds} * 2.890 \text{ ms} = 273.972 \text{ ms} (<400\text{ms})$

| Mode   | Centre Frequency (MHz) | Mode | Each second appearance transmission | Time of Occupancy (ms) | Maximum accumulated Time of Occupancy (ms) | Limit (ms) |
|--------|------------------------|------|-------------------------------------|------------------------|--|------------|
| 8-DPSK | 2480                   | 3DH1 | 10                                  | 0.390                  | 123.240                                    | <400       |
|        |                        | 3DH3 | 5                                   | 1.635                  | 258.330                                    | <400       |
|        |                        | 3DH5 | 3                                   | 2.890                  | 273.972                                    | <400       |

Observation Period:

$$79 \text{ channels} * 0.4 \text{ seconds} = 31.6 \text{ seconds}$$

**3DH1 Mode**

For each second of **10** transmission appearance, the longest time of occupancy is  
**10** transmission \* **31.6** seconds \* **0.390** ms = **123.240** ms (<400ms)

**3DH3 Mode**

For each second of **5** transmission appearance, the longest time of occupancy is  
**5** transmission \* **31.6** seconds \* **1.635** ms = **258.330** ms (<400ms)

**3DH5 Mode**

For each second of **3** transmission appearance, the longest time of occupancy is  
**3** transmission \* **31.6** seconds \* **2.890** ms = **273.972** ms (<400ms)



● Measurement Plots



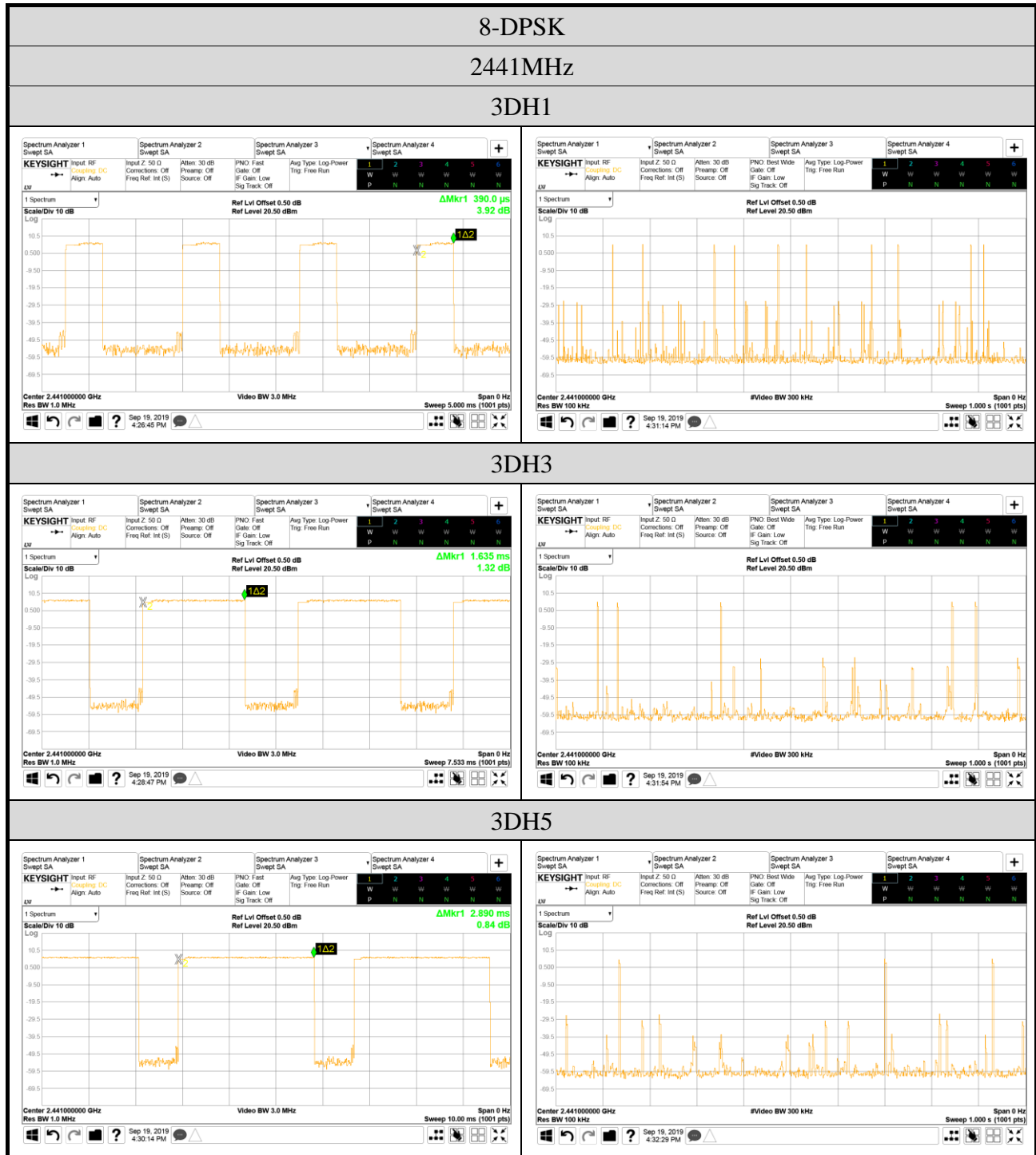

8-DPSK

2480MHz

3DH1

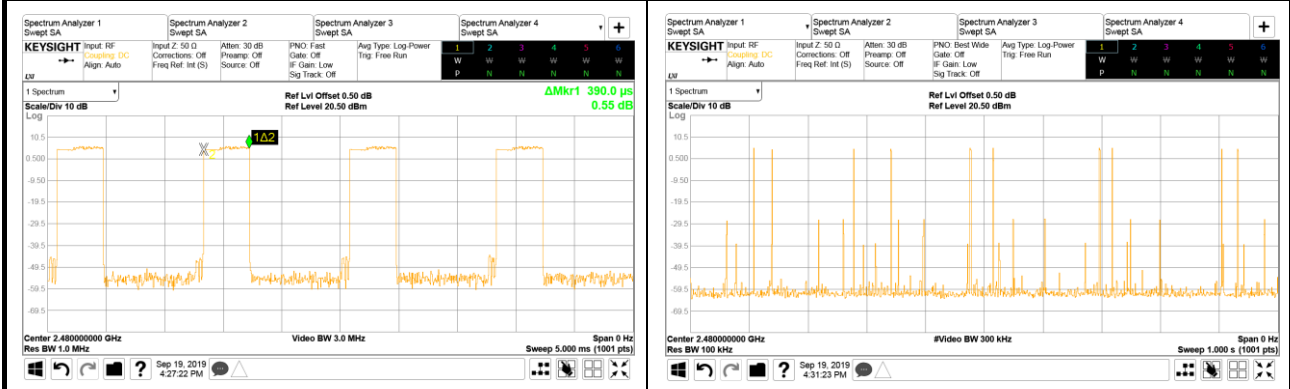

3DH3

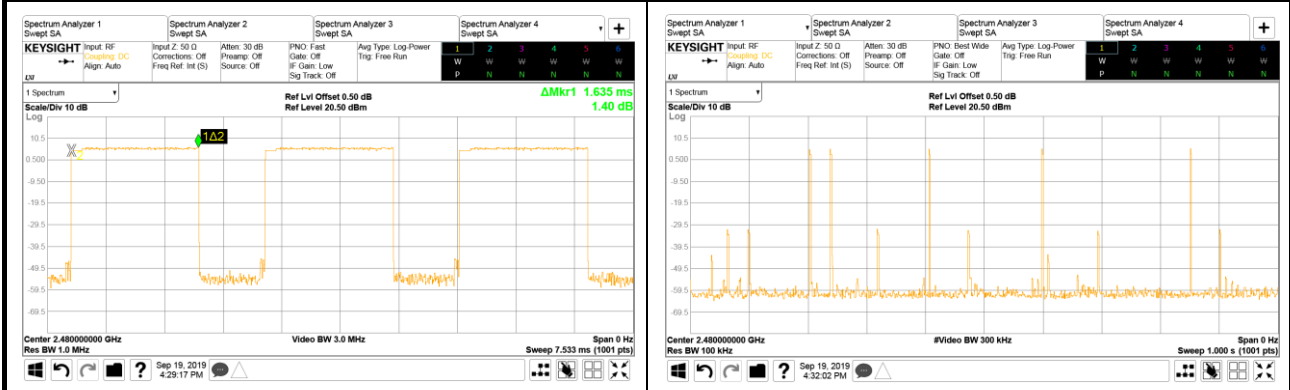

3DH5

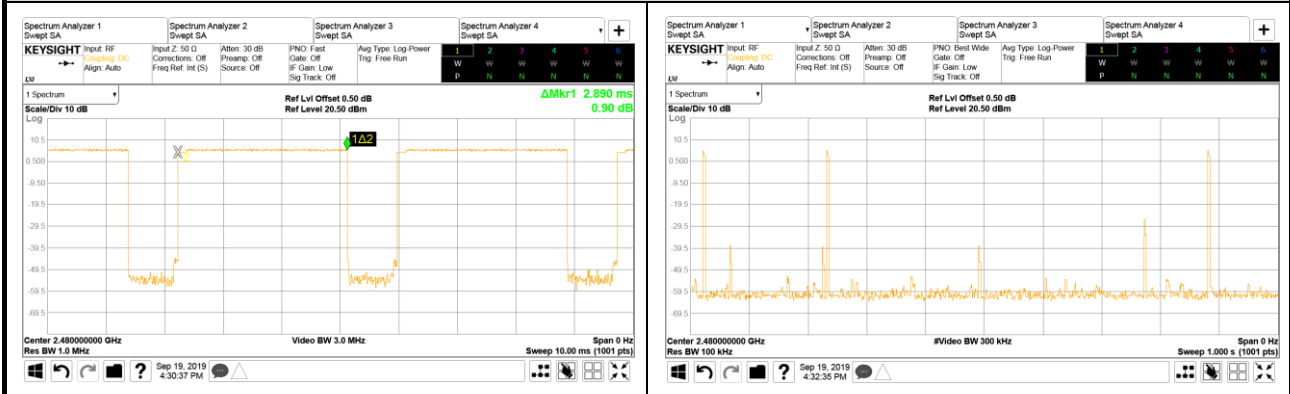

## A.6 NUMBER OF HOPPING CHANNELS

|              |                               |            |             |
|--------------|-------------------------------|------------|-------------|
| Test Date    | 2019/09/19                    | Temp./Hum. | 25°C/54%    |
| Cable Loss   | 0.50dB                        | Tested By  | Martin Chen |
| Test Voltage | AC 120V 60Hz (Via AC Adapter) |            |             |

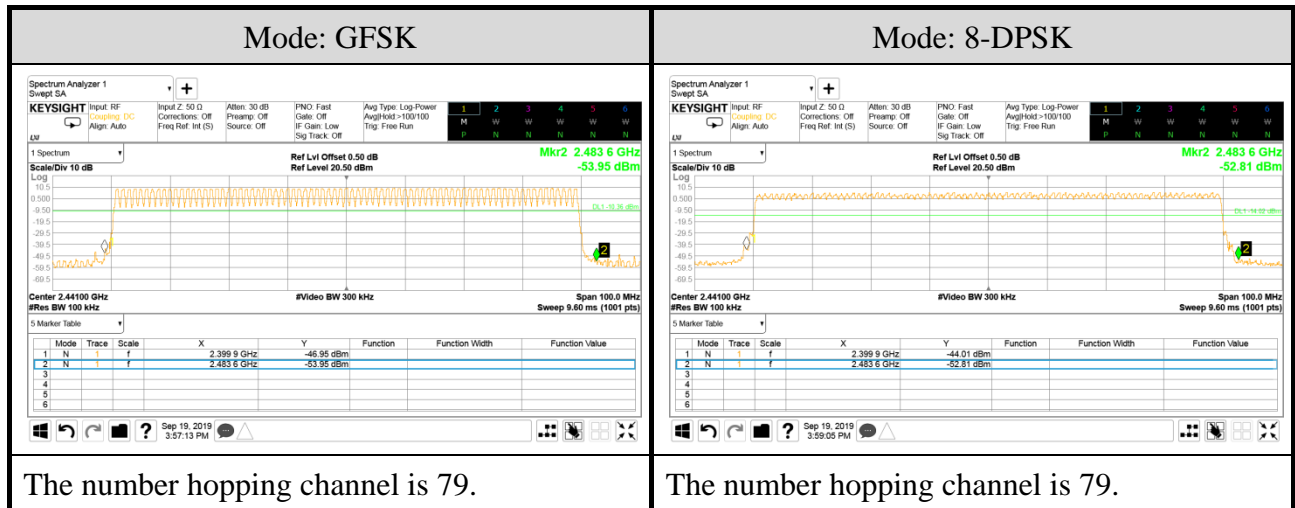

## A.7 MAXIMUM PEAK OUTPUT POWER

|              |                               |            |                    |
|--------------|-------------------------------|------------|--------------------|
| Test Date    | 2019/09/18, 2020/08/17        | Temp./Hum. | 25°C/51%, 26°C/52% |
| Cable Loss   | 0.50dB                        | Tested By  | Sean Wang          |
| Test Voltage | AC 120V 60Hz (Via AC Adapter) |            |                    |

### A.7.1 Maximum Peak Output Power

| Mode   | Centre Frequency<br>(MHz) | Maximum Peak Output Power |       | Limit             |
|--------|---------------------------|---------------------------|-------|-------------------|
|        |                           | dBm                       | W     |                   |
| GFSK   | 2402                      | 9.14                      | 0.008 | 21dBm<br>(0.125W) |
|        | 2441                      | 9.59                      | 0.009 |                   |
|        | 2480                      | 9.48                      | 0.009 |                   |
| 8-DPSK | 2402                      | 6.89                      | 0.005 |                   |
|        | 2441                      | 7.55                      | 0.006 |                   |
|        | 2480                      | 7.00                      | 0.005 |                   |

### SPOT CHECK

| Mode   | Centre Frequency<br>(MHz) | Maximum Peak Output Power |       | Limit             |
|--------|---------------------------|---------------------------|-------|-------------------|
|        |                           | dBm                       | W     |                   |
| GFSK   | 2402                      | 8.76                      | 0.008 | 21dBm<br>(0.125W) |
|        | 2441                      | 9.43                      | 0.009 |                   |
|        | 2480                      | 9.78                      | 0.010 |                   |
| 8-DPSK | 2402                      | 6.71                      | 0.005 |                   |
|        | 2441                      | 7.27                      | 0.005 |                   |
|        | 2480                      | 7.66                      | 0.006 |                   |

A.7.2 Measurement Plots

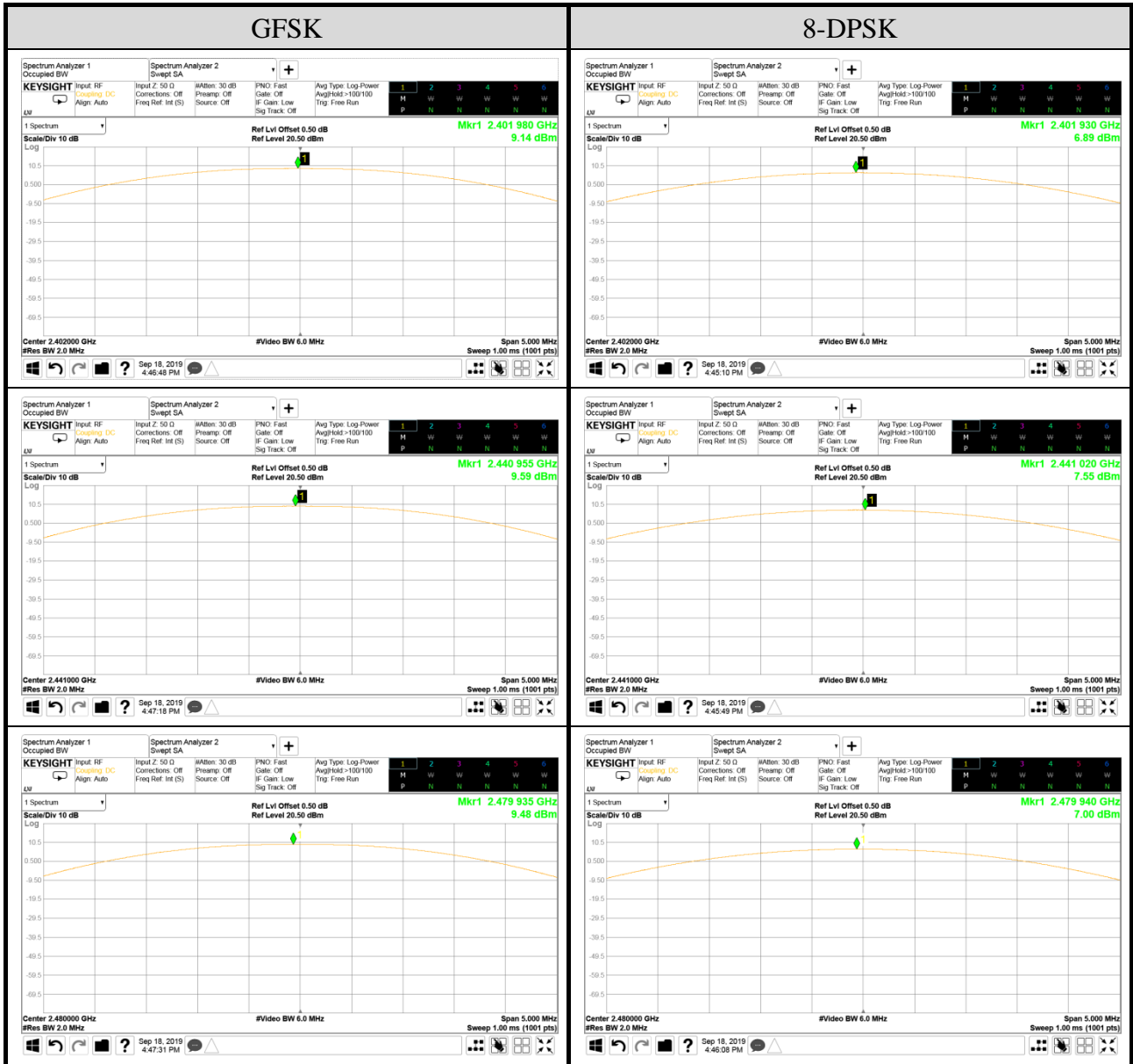

## A.8 EMISSION LIMITATIONS MEASUREMENT

|              |                               |            |               |
|--------------|-------------------------------|------------|---------------|
| Test Date    | 2019/09/18 ~ 19               | Temp./Hum. | 25°C/51 ~ 54% |
| Cable Loss   | 0.50dB                        | Tested By  | Martin Chen   |
| Test Voltage | AC 120V 60Hz (Via AC Adapter) |            |               |

### A.8.1 Band Edge



**Audix Technology Corp.**  
 No. 53-11, Dingfu, Linkou, Dist.,  
 New Taipei City 244, Taiwan

**Tel: +886 2 26099301**  
**Fax: +886 2 26099303**

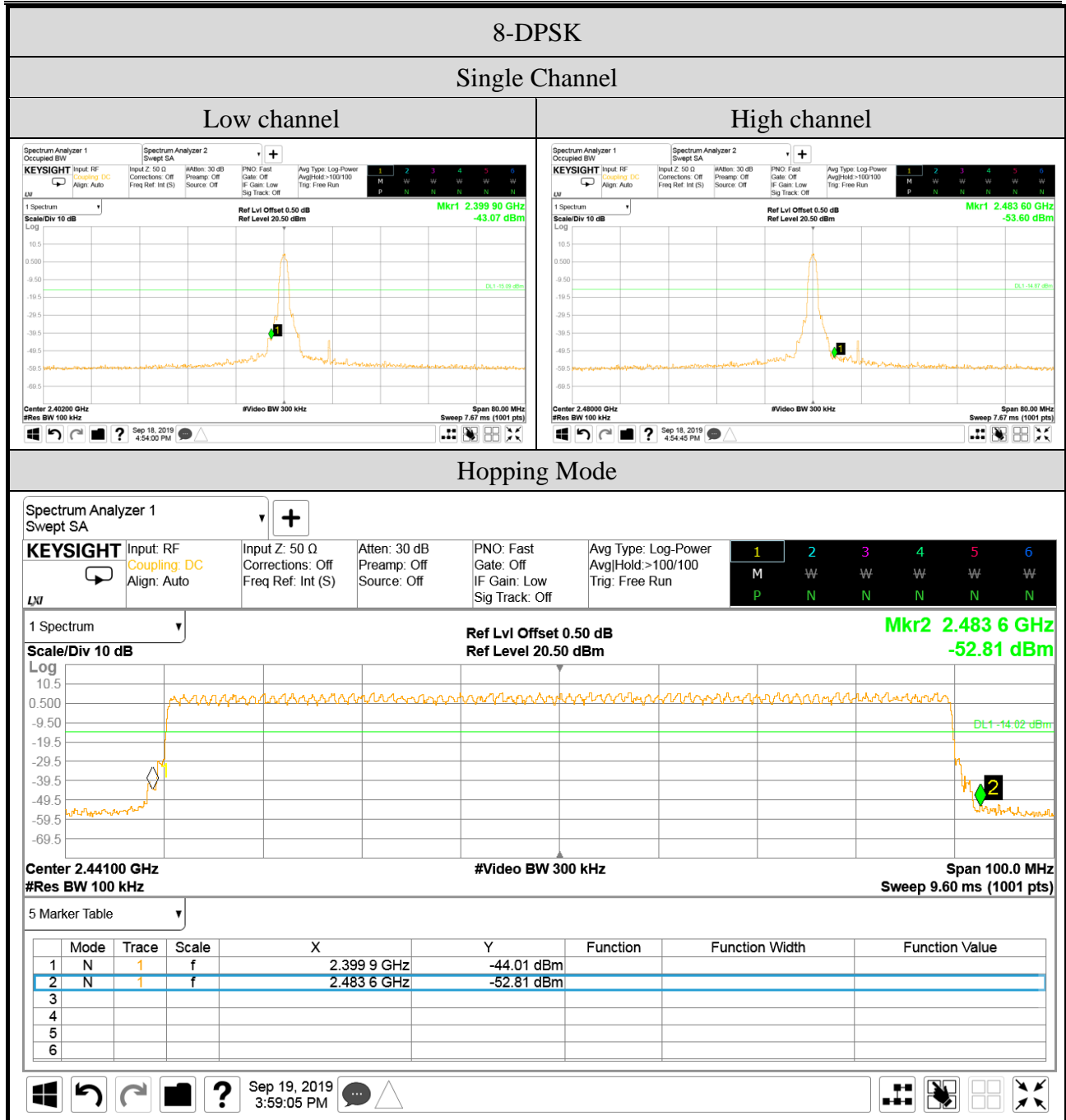



A.8.2 Spurious Emission

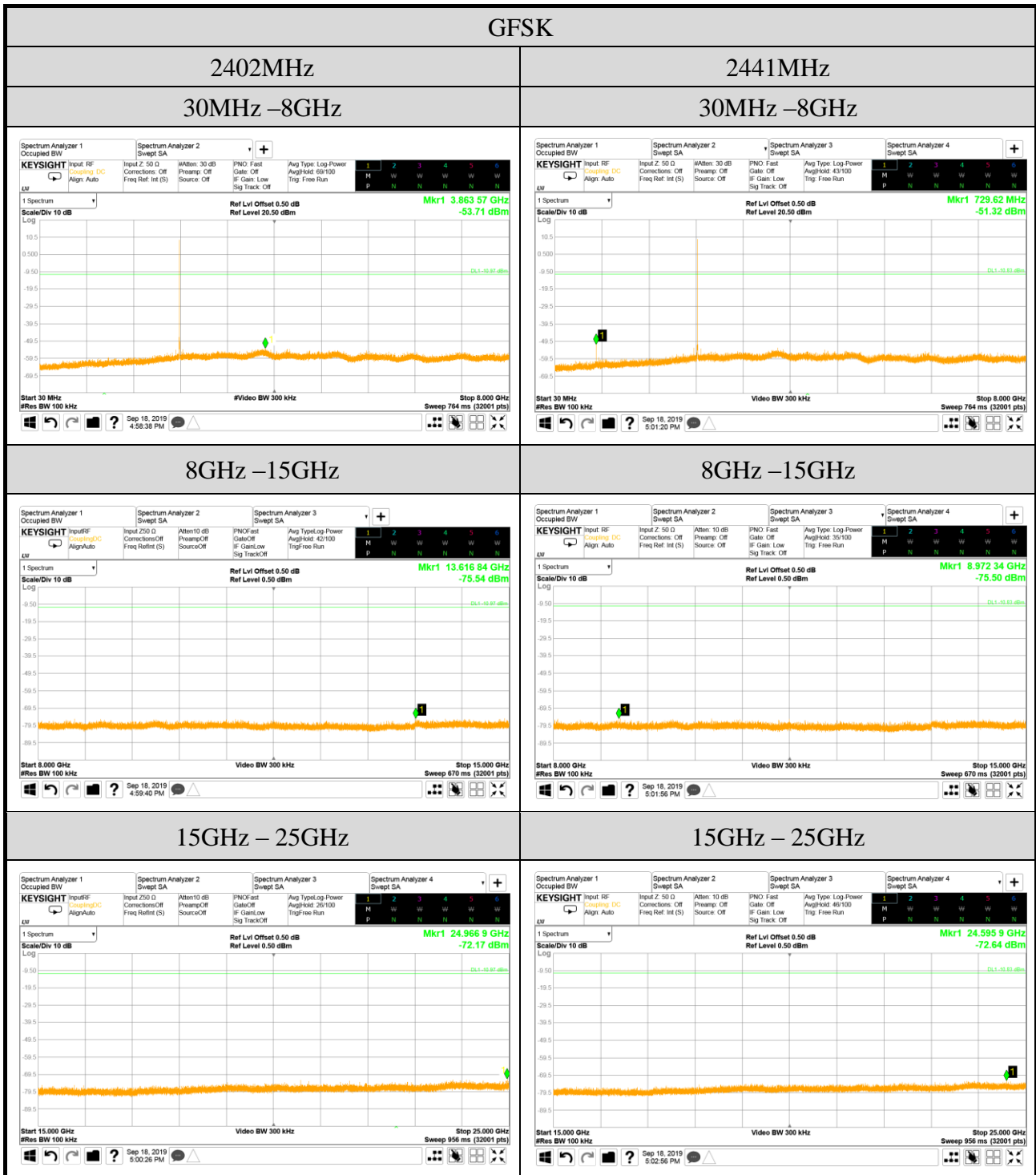

Note: All results have been included cable loss.

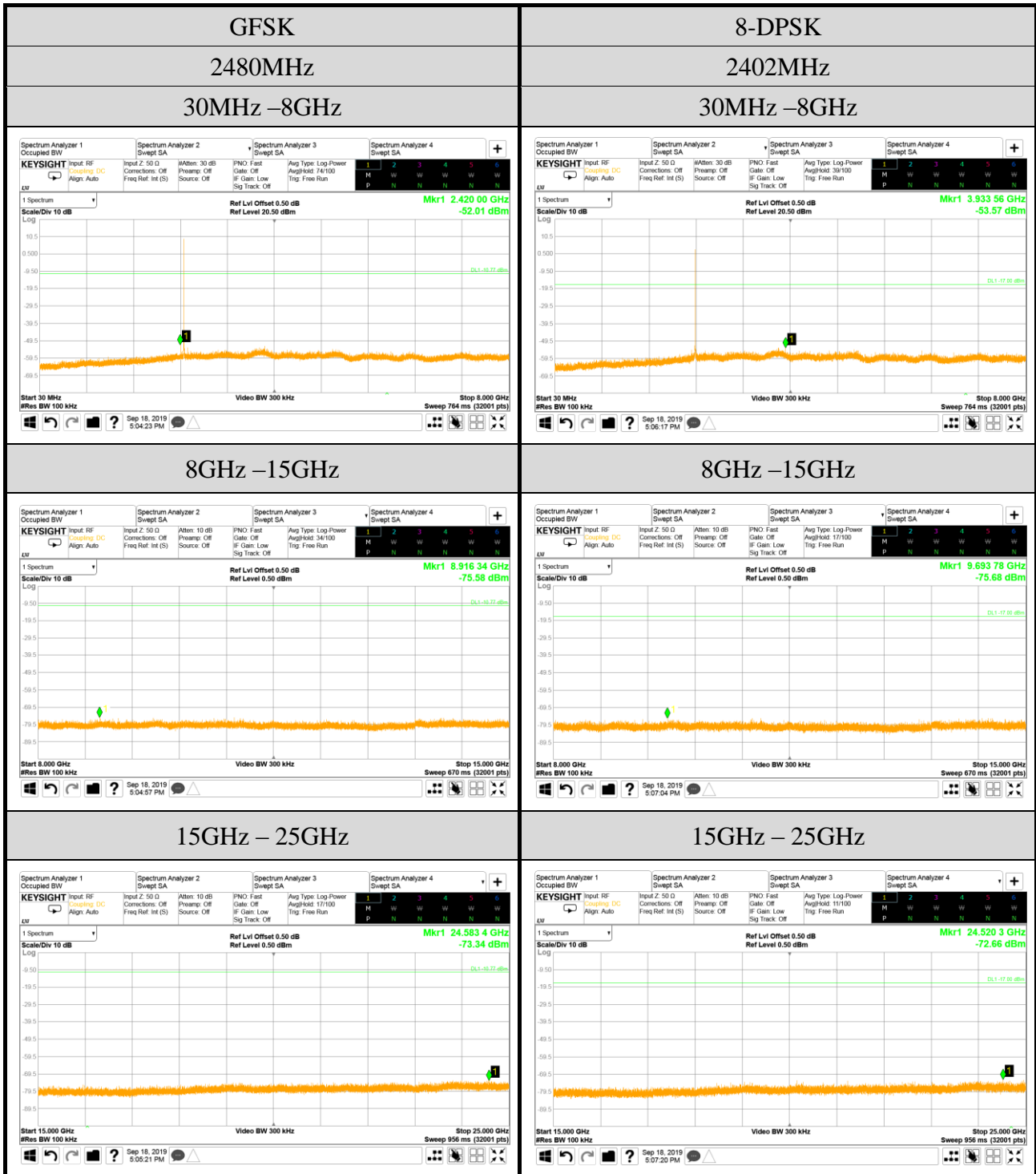

Note: All results have been included cable loss.



**Audix Technology Corp.**  
No. 53-11, Dingfu, Linkou, Dist.,  
New Taipei City 244, Taiwan

---

**APPENDIX B**

**Tel: +886 2 26099301**  
**Fax: +886 2 26099303**

# APPDNDIX B

## TEST PHOTOGRAPHS

(Model: 17Z95N)