

FCC 15.407 NII 5GHz Test Report

for

LG Electronics Inc.

**222, LG-ro, Jinwi-myeon Pyeongtaek-Si, Gyeonggi-Do,
17709 Republic of Korea**

Product Name : Notebook Computer
Model Name : (1)16Z95P (2)16ZB95P
(3)16ZD95P (4)16ZG95P
(5)16ZC95P
Brand : LG
FCC ID : BEJNT-16Z95P

**Prepared by: : AUDIX Technology Corporation,
EMC Department**



The test report is based on a single evaluation of one sample of the above-mentioned products. It does not imply an assessment of the whole production and does not permit the use of the test lab logo.

TABLE OF CONTENTS

| Description | Page |
|--|-----------|
| TEST REPORT..... | 4 |
| 1. REVISION RECORD OF TEST REPORT | 5 |
| 2. SUMMARY OF TEST RESULTS | 6 |
| 3. GENERAL INFORMATION | 7 |
| 3.1. Description of Application | 7 |
| 3.2. Description of EUT | 8 |
| 3.3. Antenna Information | 9 |
| 3.4. EUT Specifications Assessed in Current Report | 10 |
| 3.5. Description of Key Components | 13 |
| 3.6. Test Configuration..... | 15 |
| 3.7. Output Power Setting | 22 |
| 3.8. Tested Supporting System List..... | 25 |
| 3.9. Setup Configuration..... | 25 |
| 3.10. Operating Condition of EUT | 26 |
| 3.11. Description of Test Facility | 26 |
| 3.12. Measurement Uncertainty | 27 |
| 4. MEASUREMENT EQUIPMENTLIST..... | 28 |
| 4.1. Conducted Emission Measurement | 28 |
| 4.2. Radiated Emission Measurement | 29 |
| 4.3. RF Conducted Measurement | 29 |
| 5. CONDUCTED EMISSION..... | 30 |
| 5.1. Block Diagram of Test Setup | 30 |
| 5.2. Conducted Emission Limit | 30 |
| 5.3. Test Procedure | 30 |
| 5.4. Test Results | 31 |
| 6. RADIATED EMISSION | 32 |
| 6.1. Block Diagram of Test Setup | 32 |
| 6.2. Radiated Emission Limits..... | 34 |
| 6.3. Test Procedure | 36 |
| 6.4. Measurement Result Explanation..... | 37 |
| 6.5. Test Results | 37 |
| 7. 26dB/6dB BANDWIDTH | 38 |
| 7.1. Block Diagram of Test Setup | 38 |
| 7.2. Specification Limits..... | 38 |
| 7.3. Test Procedure | 38 |
| 7.4. Test Results | 38 |
| 8. MAXIMUM OUTPUT POWER | 39 |
| 8.1. Block Diagram of Test Setup | 39 |
| 8.2. Specification Limits..... | 39 |
| 8.3. Test Procedure | 40 |
| 8.4. Test Results | 40 |
| 9. POWER SPECTRAL DENSITY | 41 |
| 9.1. Block Diagram of Test Setup | 41 |
| 9.2. Specification Limits..... | 41 |



Audix Technology Corp.
No. 491, Zhongfu Rd., Linkou Dist.,
New Taipei City 244, Taiwan

Tel: +886 2 26099301
Fax: +886 2 26099303

| | |
|---|-----------|
| 9.3. Test Procedure | 41 |
| 9.4. Test Results | 41 |
| 10. FREQUENCY STABILITY | 42 |
| 10.1. Block Diagram of Test Setup | 42 |
| 10.2. Specification Limits..... | 42 |
| 10.3. Test Procedure | 42 |
| 10.4. Test Results | 42 |
| 11. DEVIATION TO TEST SPECIFICATIONS | 43 |

APPENDIX A TEST DATA AND PLOTS
APPENDIX B TESTPHOTOGRAPHS

TEST REPORT

Applicant : LG Electronics Inc.
Manufacturer : LG Electronics Inc.
Factory #1 : LG Electronics Nanjing New Technology Co., Ltd.
Factory #2 : LG Electronics Do Brasil Ltda. (048130)
EUT Description
(1) Product : Notebook Computer
(2) Model : (1)16Z95P (2)16ZB95P (3)16ZD95P (4)16ZG95P (5)16ZC95P
(3) Brand : LG
(4) Power Supply: DC 20V, 3.25A

Applicable Standards:

Title 47 FCC CFR Part 15 Subpart E
ANSI C63.10:2013
KDB 789033 D02 General UNII Test Procedures New Rules v02r01

Audix Technology Corp. tested the equipment mentioned in accordance with the requirements set forth in the above standards. Test results indicate that the equipment tested is capable of demonstrating compliance with the requirements as documented within this report.

Audix Technology Corp. does not assume responsibility for any conclusions and generalizations drawn from the test results with regard to other specimens and samples.

Date of Report: 2021. 07. 21

Reviewed by:



(Annie Yu/Administrator)

Approved by:

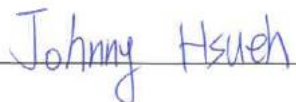

(Johnny Hsueh/Section Manager)

1. REVISION RECORD OF TEST REPORT

| Edition No | Issued Data | Revision Summary | Report Number |
|------------|--------------|------------------|---------------|
| 0 | 2021. 07. 21 | Original Report | EM-F210482 |

2. SUMMARY OF TEST RESULTS

| Rule | Description | Data Reused | Results |
|------------------------|---|-------------|------------|
| 15.207 | Conducted Emission | No | PASS |
| 15.205/15.209 | Radiated Band Edge and Radiated Spurious Emission | No | PASS |
| 15.407(a)(5)/15.407(e) | 26dB/6dB Bandwidth | No | PASS |
| 15.407(a) | Maximum Output Power | No | PASS |
| 15.407(b) | Conducted Band Edges | No | N/A |
| 15.407(a) | Power Spectral Density | No | PASS |
| 15.407 | Frequency Stability | No | PASS |
| 15.203 | Antenna Requirement | --- | Compliance |

Note: The uncertainties value is not used in determining the result.

3. GENERAL INFORMATION

3.1. Description of Application

| | |
|--------------|--|
| Applicant | LG Electronics Inc. 222, LG-ro, Jinwi-myeon Pyeongtaek-Si, Gyeonggi-Do, 17709 Republic of Korea |
| Manufacturer | LG Electronics Inc. 222, LG-ro, Jinwi-myeon Pyeongtaek-Si, Gyeonggi-Do, 17709 Republic of Korea |
| Factory #1 | LG Electronics Nanjing New Technology Co., Ltd. No.346,Yaoxin Road, Economic & Technical Development Zone, Nanjing, China. |
| Factory #2 | LG Electronics Do Brasil Ltda. (048130) Avenida Dom Pedro 1, W7777 12091-000 D.I.Piracangagua II,Taubate-SP BRAZIL |
| Product | Notebook Computer |
| Model | (1)16Z95P (2)16ZB95P (3)16ZD95P (4)16ZG95P (5)16ZC95P The difference between all models is different in the sales customers. |
| Brand | LG |

3.2. Description of EUT

| | | | |
|------------------------|---|--|----------|
| Test Model | 16Z95P | | |
| Serial Number | N/A | | |
| Power Rating | DC 20V, 3.52A | | |
| RF Features | WLAN: 802.11 a/b/g/n/ac/ax Bluetooth: BT and BLE (BT 5.0) | | |
| Transmit Type | 2.4 GHz | | |
| | 802.11b | | 1T1R |
| | 802.11g | | 1T1R |
| | 802.11n-HT20 | | 2T2R |
| | 802.11n-HT40 | | 2T2R |
| | 802.11ax-HE20 | | 2T2R |
| | 802.11ax-HE40 | | 2T2R |
| | BT/BLE | | 1T1R |
| | U-NII Bands | | |
| | 802.11a | | 1T1R |
| | 802.11n-HT20/802.11ac-VHT20/802.11ax-HE20 | | 2T2R |
| | 802.11n-HT40/802.11ac-VHT40/802.11ax-HE40 | | 2T2R |
| | 802.11ac-VHT80/802.11ax-HE80 | | 2T2R |
| | 802.11ac-VHT160/802.11ax-HE160 | | 2T2R |
| | The MIMO is uncorrelated and supported SDM mode only. | | |
| | Device Category | <input type="checkbox"/> Outdoor Access Point <input type="checkbox"/> Fixed point-to-point Access Point <input type="checkbox"/> Indoor Access Point <input checked="" type="checkbox"/> Mobile and Portable client device | |
| Test Sample | Sample No. | Test Item | Firmware |
| | 01 | AC Conduction, RSE, Output Power | N/A |
| | 02 | AC Conduction, Output Power | N/A |
| Sample Status | Mass production | | |
| Date of Receipt | 2021. 06. 09 | | |
| Date of Test | 2021. 06. 29 ~ 07. 20 | | |
| Interface Ports of EUT | <ul style="list-style-type: none"> • One Micro SD Card Slot • One Earphone Port • Two USB 3.0 Ports • Two USB Type C Ports • One HDMI Port | | |
| Accessories Supplied | <ul style="list-style-type: none"> • AC Adapter • LAN Gender | | |

3.3. Antenna Information

| No. | Antenna Part Number | Manufacture | Antenna Type | Frequency (MHz) | Max Gain(dBi) |
|-----|----------------------------|------------------|--------------|-----------------|---------------|
| 1. | WA-P-LELE-04-002 (Main) | INPAQ | Mono-Pole | 2400~2500 | 5.0 |
| | | | | 5100-5250 | 3.8 |
| | | | | 5250-5350 | 3.8 |
| | | | | 5350-5750 | 2.4 |
| | | | | 5750~5850 | 2.7 |
| | WA-P-LELE-04-002 (AUX) | INPAQ | Mono-Pole | 2400~2500 | 5.7 |
| | | | | 5100-5250 | 3.8 |
| | | | | 5250-5350 | 3.8 |
| | | | | 5350-5750 | 2.4 |
| | | | | 5750~5850 | 2.7 |
| 2. | L1LRF004-CS-H (Main) | LUXSHARE- ICT | Mono-Pole | 2400~2500 | 1.8 |
| | | | | 5150-5250 | 2.0 |
| | | | | 5250-5350 | 2.2 |
| | | | | 5350-5725 | 2.8 |
| | | | | 5725~5850 | 2.2 |
| | L1LRF004-CS-H (AUX) | LUXSHARE- ICT | Mono-Pole | 2400~2500 | 1.5 |
| | | | | 5150-5250 | 2.0 |
| | | | | 5250-5350 | 2.0 |
| | | | | 5350-5725 | 2.6 |
| | | | | 5725~5850 | 2.7 |

3.4. EUT Specifications Assessed in Current Report

| Mode | U-NII Band | Fundamental Range (MHz) | Channel Number |
|--|------------|-------------------------|----------------|
| 802.11a | I | 5180-5240 | 4 |
| | 2A | 5260-5320 | 4 |
| | 2C | 5500-5720 | 12 |
| | III | 5745-5825 | 5 |
| 802.11n-HT20/ 802.11ac-VHT20 802.11ax-HE20 | I | 5180-5240 | 4 |
| | 2A | 5260-5320 | 4 |
| | 2C | 5500-5720 | 12 |
| | III | 5745-5825 | 5 |
| 802.11n-HT40/ 802.11ac-VHT40 802.11ax-HE40 | I | 5190-5230 | 2 |
| | 2A | 5270-5310 | 2 |
| | 2C | 5510-5710 | 6 |
| | III | 5755-5795 | 2 |
| 802.11ac-VHT80 802.11ax-HE80 | I | 5210 | 1 |
| | 2A | 5290 | 1 |
| | 2C | 5530-5690 | 3 |
| | III | 5775 | 1 |
| 802.11ac-VHT160 802.11ax-HE160 | I | 5250 | 1 |
| | 2A | | |
| | 2C | 5570 | 1 |
| Remark: U-NII Band 2A and 2C (DFS Function, Slave/no In service monitor, no Ad-Hoc mode) | | | |

| Mode | Modulation | Data Rate (Mbps) |
|-----------------|--|------------------|
| 802.11a | OFDM (BPSK/QPSK/16QAM/64QAM) | Up to 54 |
| 802.11n-HT20 | OFDM (BPSK/QPSK/16QAM/64QAM) | Up to 144.4 |
| 802.11n-HT40 | | Up to 300 |
| 802.11ac-VHT20 | OFDM (BPSK/QPSK/16QAM/64QAM/256QAM) | Up to 173.3 |
| 802.11ac-VHT40 | | Up to 400 |
| 802.11ac-VHT80 | | Up to 866.7 |
| 802.11ac-VHT160 | | Up to 1733.3 |
| 802.11ax-HE20 | OFDMA (BPSK/ QPSK/ 16QAM/ 64QAM/ 256QAM/1024QAM) | Up to 287 |
| 802.11ax-HE40 | | Up to 574 |
| 802.11ax-HE80 | | Up to 1201 |
| 802.11ax-HE160 | | Up to 2402 |

| Channel List | | | | | | |
|---|----------------|-----------------|------------|----------------|-----------------|------|
| 802.11a/802.11n-HT20/802.11ac-VHT20/802.11ax-HE20 | | | | | | |
| U-NII Band | Channel Number | Frequency (MHz) | U-NII Band | Channel Number | Frequency (MHz) | |
| I | 36 | 5180 | 2C | 120 | 5600 | |
| | 40 | 5200 | | 124 | 5620 | |
| | 44 | 5220 | | 128 | 5640 | |
| | 48 | 5240 | | 132 | 5660 | |
| 2A | 52 | 5260 | | 136 | 5680 | |
| | 56 | 5280 | | 140 | 5700 | |
| | 60 | 5300 | | 144 | 5720 | |
| | 64 | 5320 | | 149 | 5745 | |
| 2C | 100 | 5500 | | III | 153 | 5765 |
| | 104 | 5520 | | | 157 | 5785 |
| | 108 | 5540 | 161 | | 5805 | |
| | 112 | 5560 | 165 | | 5825 | |
| | 116 | 5580 | | | | |

| Channel List | | | | | |
|---|----------------|-----------------|------------|----------------|-----------------|
| 802.11n-HT40/802.11ac-VHT40/802.11ax-HE40 | | | | | |
| U-NII Band | Channel Number | Frequency (MHz) | U-NII Band | Channel Number | Frequency (MHz) |
| I | 38 | 5190 | 2C | 118 | 5590 |
| | 46 | 5230 | | 126 | 5630 |
| 2A | 54 | 5270 | | 134 | 5670 |
| | 62 | 5310 | | 142 | 5710 |
| 2C | 102 | 5510 | III | 151 | 5755 |
| | 110 | 5550 | | 159 | 5795 |

| Channel List | | | | | |
|------------------------------|----------------|-----------------|------------|----------------|-----------------|
| 802.11ac-VHT80/802.11ax-HE80 | | | | | |
| U-NII Band | Channel Number | Frequency (MHz) | U-NII Band | Channel Number | Frequency (MHz) |
| I | 42 | 5210 | 2C | 138 | 5690 |
| 2A | 58 | 5290 | III | 155 | 5775 |
| 2C | 106 | 5530 | | | |
| | 122 | 5610 | | | |

| Channel List | | | | | |
|--------------------------------|----------------|-----------------|------------|----------------|-----------------|
| 802.11ac-VHT160/802.11ax-HE160 | | | | | |
| U-NII Band | Channel Number | Frequency (MHz) | U-NII Band | Channel Number | Frequency (MHz) |
| I | 50 | 5250 | 2C | 114 | 5570 |
| 2A | | | | | |

Note: Test modes are presented at section 3.7.

3.5. Description of Key Components

3.5.1. For the All Component Lists

| Item | Supplier | Model / Type | Character |
|----------------------------|-------------------|--------------------|--|
| System | Microsoft | Win10 Home | --- |
| | | Win10 Pro | --- |
| Main Board | LG | Blanc MAIN B/D PCB | Manufacturer: #1 Hannstar Board Tech(Jiang Yin) Corp.,Ltd. #2 Elec & Eltek Company (MCO) Limited. |
| WLAN SUB Board | LG | 15/16Z90P Sub B/D | Manufacturer: #1 Hannstar Board Tech(Jiang Yin) Corp.,Ltd. #2 Elec & Eltek Company (MCO) Limited. #3 JiangSu HuaShen Electronic co.,ltd (HXF) |
| CPU (Socket: FCBGA1449) | Intel | i7-1195G7 | 2.9GHz |
| | Intel | i5-1155G7 | 2.5GHz |
| 16" LCD Panel | LG Display | LP160WQ1(SP)(A1) | Resolution: 2560 x 1600, 60Hz WQXGA IPS (Non Touch) |
| Storage (SSD) | SK hynix | HFM256GD3JX013N | 256GB (M.2) |
| | | HFM512GD3JX013N | 512GB (M.2) |
| | | HFM001TD3JX013N | 1TB (M.2) |
| Memory (RAM) | Samsung | --- | 16GB LPDDR4x(On Board) |
| | Samsung | --- | 8GB LPDDR4x(On Board) |
| | SK Hynix | --- | 16GB LPDDR4x(On Board) |
| | SK Hynix | --- | 8GB LPDDR4x(On Board) |
| | SK Hynix | --- | 32GB LPDDR4x(On Board) |
| Battery Pack | LG | LBV7227E | 80Wh, DC 7.74V, 80Wh Typ 10336mAh |
| WLAN Combo Card | Intel | AX201D2W | WLAN and BT, 2x2 CNVi 1216 FCC ID: PD9AX201NG IC: 1000M-AX201NG NCC ID: CCAH18LP3410T5 |
| WLAN Combo Antenna | LG (INPAQ) | WA-P-LELE-04-002 | PCB, Mono-pole Type Main: Black, Aux: Gray |
| | LG (LUXSHARE-ICT) | L1LRF004-CS-H | PCB, Mono-pole Typ Main: Black, Aux: Gray |

| Item | Supplier | Model / Type | Character |
|--|--|--------------------|---|
| Keyboard | TIC | KT0120B9 | --- |
| | LITE ON | SN8002 | --- |
| Web Camera | Chicony | CKFKH33-0 | --- |
| | Luxvisions | 0BF108N3 | --- |
| LAN Gender (Type C to LAN) | SUZHOU MEC ELECTRONICS | 80-5946-111 | (White) 10/100 Megabit Ethernet |
| | | 80-5946-101 | (Black) 10/100 Megabit Ethernet |
| | Type C to LAN: Shielded, Undetached, 0.12m | | |
| | ARIN TECH CO. LTD | GD-08MF-36-WH-LP10 | (White) 10/100 Megabit Ethernet |
| | | GD-08MF-36-BK-LP11 | (Black) 10/100 Megabit Ethernet |
| | Type C to LAN: Shielded, Undetached, 0.12m | | |
| | SUZHOU MEC ELECTRONICS | 80-5946-200 | (White) 10/100/1000 Megabit Ethernet |
| | | 80-5946-210 | (Black) 10/100/1000 Megabit Ethernet |
| Type C to LAN: Shielded, Undetached, 0.13m | | | |
| AC Adapter (65W) | LG (HONOR) | ADT-65DSU-D03-2 | I/P: AC 100-240V, 1.6A, 50-60Hz O/P: DC 20V, 3.25A |
| | DC Power Cord: Non-Shielded, Undetached, 1.5m | | |
| | AC Power Cord: Non-Shielded, Detached, 1.0m (2C) (For Other Countries) AC Power Cord: Non-Shielded, Detached, 1.55m (2C) (For US, Canada, Mexico) | | |

Remark: For more detailed features description, please refer to the manufacturer's specifications or the user manual.

3.5.2. The EUT collocates with following worst components, which are used to establish a basic configuration of system during test:

| SKU | | #1 | #2 |
|--------------------|---|----|----|
| Main Board | LG, Blanc MAIN B/D PCB | V | V |
| WLAN SUB Board | LG, 15/16Z90P Sub B/D | V | V |
| CPU | Intel, i7-1195G7 | V | V |
| 16" LCD Panel | LG Display, LP160WQ1(SP)(A1) | V | V |
| Storage (SSD) | SK Hynix, 1TB | V | |
| Memory (RAM) | SK Hynix, 32GB | V | V |
| Battery Pack | LG, Lbv7227E | V | V |
| WLAN Combo Card | Intel, AX201D2W | V | V |
| WLAN Combo Antenna | LG (INPAQ), WA-P-LELE-04-002 | V | |
| WLAN Combo Antenna | LG (LUXSHARE-ICT), L1LRF004-CS-H | | V |
| Keyboard | LITE ON, SN8002 | V | V |
| Web Camera | Chicony, CKFKH33-0 | V | V |
| Type C | Link to LAN Gender | | |
| | SUZHOU MEC ELECTRONICS, 80-5946-111 (White) | V | |
| AC Adapter | LG (HONOR), ADT-65DSU-D03-2 | V | V |

3.6. Test Configuration

| Mode | TX _{on} (ms) | 1/ TX _{on} (kHz) | Duty Cycle (x) | Duty Cycle Factor [10log(1/x)] (dB) |
|-----------------|-----------------------|---------------------------|----------------|--|
| 802.11a | 2.087 | 0.479 | 0.983 | N/A |
| 802.11n-HT20 | 3.980 | 0.251 | 0.990 | N/A |
| 802.11n-HT40 | 3.980 | 0.251 | 0.993 | N/A |
| 802.11ac-VHT80 | 3.960 | 0.253 | 0.990 | N/A |
| 802.11ac-VHT160 | 2.780 | 0.360 | 0.986 | N/A |
| 802.11ax-HE20 | 3.970 | 0.252 | 0.993 | N/A |
| 802.11ax-HE40 | 3.970 | 0.252 | 0.993 | N/A |
| 802.11ax-HE80 | 3.980 | 0.251 | 0.990 | N/A |
| 802.11ax-HE160 | 2.280 | 0.439 | 0.983 | N/A |

Note: When duty cycle is less than 98% (0.98) that duty cycle factor 10log(1/x) is needed to add in conducted test items measured in average detector.



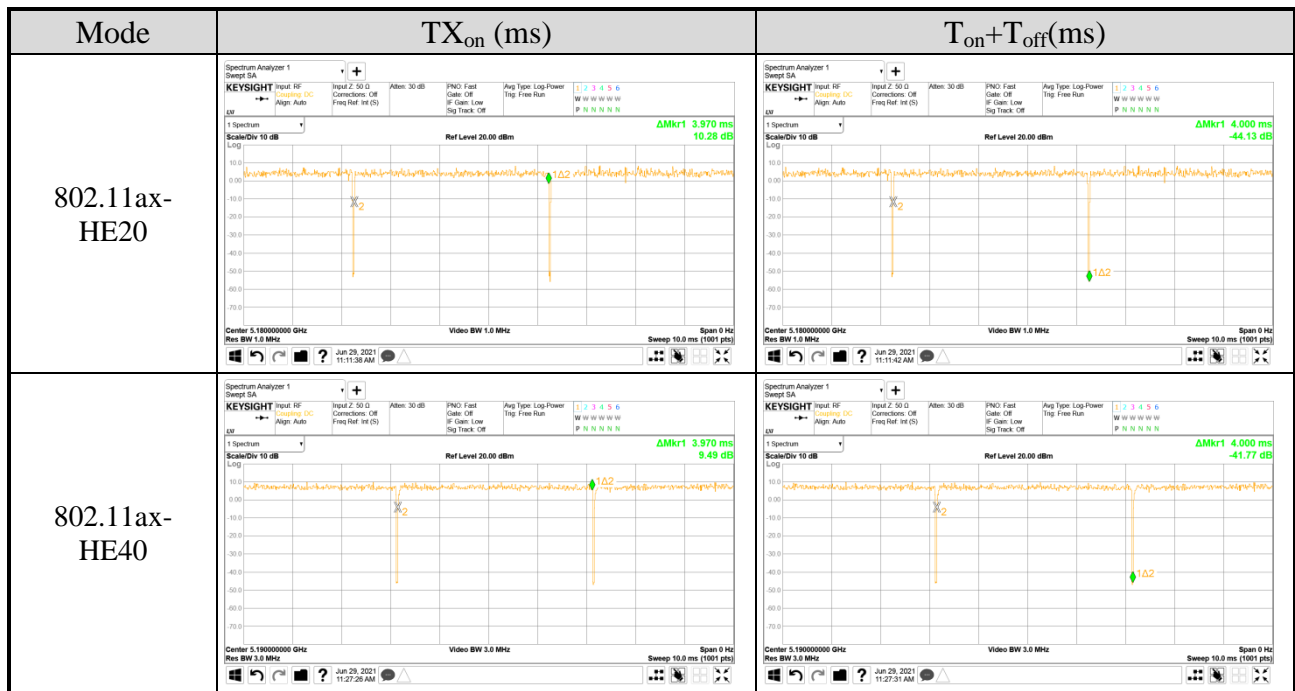
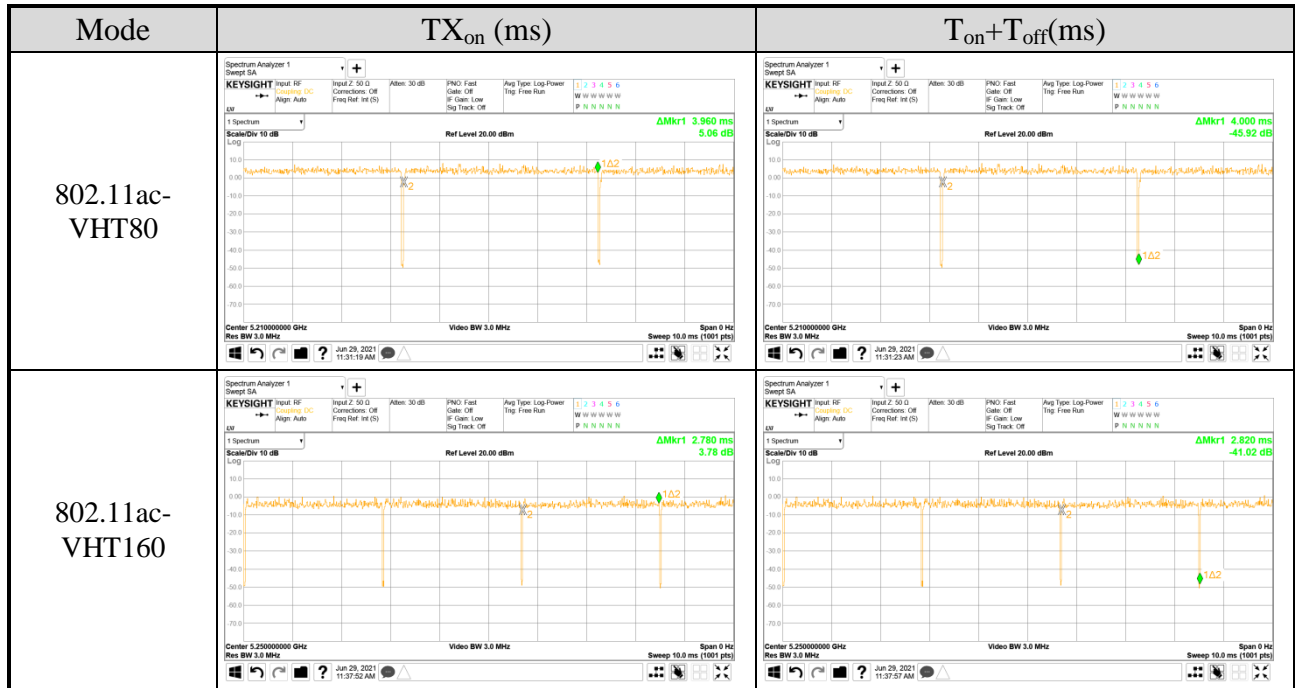

| Mode | TX _{on} (ms) | T _{on} +T _{off} (ms) |
|----------------|-----------------------|--|
| 802.11ax-HE80 | | |
| 802.11ax-HE160 | | |

| AC Conduction | |
|---------------|---|
| SKU #1 | Normal operation(with LUXSHARE-ICT Antenna) |
| SKU #2 | Normal operation(with INPAQ Antenna) |

| Item | | Mode | Data Rate | Test Channel | |
|--------------------|-------|---|-------------------|--------------|---------------------------|
| Radiated Test Case | SKU#1 | Radiated Band Edge Note 1 & 3 | 802.11a | 6 Mbps | 36/64/100/140/144/149/165 |
| | | | 802.11n-HT20 | MCS8 | 36/64/100/140/144/149/165 |
| | | | 802.11n-HT40 | MCS8 | 38/62/102/134/142/151/159 |
| | | | 802.11ac-VHT80 | MCS0 | 42/58/106/122/138/155 |
| | | | 802.11ac-VHT160 | MCS0 | 50/114 |
| | | | 802.11ax-HE20 | HE0 | 36/64/100/140/144/149/165 |
| | | | 802.11ax-HE40 | HE0 | 38/62/102/134/142/151/159 |
| | | | 802.11ax-HE80 | HE0 | 42/58/106/122/138/155 |
| | | 802.11ax-HE160 | HE0 | 50/114 | |
| | | Radiated Spurious Emission ^{Note} 1 & 2 & 3 | 802.11a | 6 Mbps | 48/52/116/144/149 |
| | | | 802.11n-HT20 | MCS8 | 48/52/116/144/157 |
| | | | 802.11n-HT40 | MCS8 | 46/54/134/142/159 |
| | | | 802.11ac-VHT80 | MCS0 | 42/58/122/138/155 |
| | | | 802.11ac-VHT160 | MCS0 | 50/114 |
| | | | 802.11ax-HE20 | HE0 | 48/52/116/144/157 |
| | | | 802.11ax-HE40 | HE0 | 46/54/134/142/159 |
| 802.11ax-HE80 | HE0 | | 42/58/122/138/155 | | |
| 802.11ax-HE160 | HE0 | 50/114 | | | |

| Item | | Mode | Data Rate | RU Configuration | Test Channel | |
|--------------------|---------|----------------------------------|----------------|------------------|--------------|------------|
| Radiated Test Case | SKU#1 | Radiated Band Edge Note 1 & 3 | 802.11ax-HE20 | HE0 | 26/0 | 36/100/149 |
| | | | | | 52/37 | |
| | | | | | 106/53 | |
| | | | | HE0 | 26/8 | 64/140/165 |
| | | | | | 52/40 | |
| | | | | | 106/54 | |
| | | | 802.11ax-HE40 | HE0 | 242/61 | 38/102/151 |
| | | | | HE0 | 242/62 | 62/134/159 |
| | | | 802.11ax-HE80 | HE0 | 484/65 | 42/106/155 |
| | | | | HE0 | 484/66 | 58/122/155 |
| | | | 802.11ax-HE160 | HE0 | 996/67 | 50/114 |
| | | | | HE0 | 996/S67 | 50/114 |
| HE0 | 996/S67 | 50/114 | | | | |

| Item | | Mode | Data Rate | Test Channel |
|---------------------|------------------------|-----------------|-------------------------------------|---|
| Conducted Test Case | 26dB/6dB Bandwidth | 802.11a | 6 Mbps | 36/40/48/52/60/64/100/116/140/144/149/157/165 |
| | | 802.11n-HT20 | MCS8 | 36/40/48/52/60/64/100/116/140/144/149/157/165 |
| | | 802.11n-HT40 | MCS8 | 38/46/54/62/102/110/134/142/151/159 |
| | | 802.11ac-VHT80 | MCS0 | 42/58/106/122/138/155 |
| | | 802.11ac-VHT160 | MCS0 | 50/114 |
| | | 802.11ax-HE20 | HE0 | 36/40/48/52/60/64/100/116/140/144/149/157/165 |
| | | 802.11ax-HE40 | HE0 | 38/46/54/62/102/110/134/142/151/159 |
| | | 802.11ax-HE80 | HE0 | 42/58/106/122/138/155 |
| | 802.11ax-HE160 | HE0 | 50/114 | |
| | Maximum output power | 802.11a | 6 Mbps | 36/40/48/52/60/64/100/116/140/144/149/157/165 |
| | | 802.11n-HT20 | MCS8 | 36/40/48/52/60/64/100/116/140/144/149/157/165 |
| | | 802.11n-HT40 | MCS8 | 38/46/54/62/102/110/134/142/151/159 |
| | | 802.11ac-VHT80 | MCS0 | 42/58/106/122/138/155 |
| | | 802.11ac-VHT160 | MCS0 | 50/114 |
| | | 802.11ax-HE20 | HE0 | 36/40/48/52/60/64/100/116/140/144/149/157/165 |
| | | 802.11ax-HE40 | HE0 | 38/46/54/62/102/110/134/142/151/159 |
| | | 802.11ax-HE80 | HE0 | 42/58/106/122/138/155 |
| | 802.11ax-HE160 | HE0 | 50/114 | |
| | Power spectral density | 802.11a | 6 Mbps | 36/40/48/52/60/64/100/116/140/144/149/157/165 |
| | | 802.11n-HT20 | MCS8 | 36/40/48/52/60/64/100/116/140/144/149/157/165 |
| | | 802.11n-HT40 | MCS8 | 38/46/54/62/102/110/134/142/151/159 |
| | | 802.11ac-VHT80 | MCS0 | 42/58/106/122/138/155 |
| | | 802.11ac-VHT160 | MCS0 | 50/114 |
| | | 802.11ax-HE20 | HE0 | 36/40/48/52/60/64/100/116/140/144/149/157/165 |
| 802.11ax-HE40 | | HE0 | 38/46/54/62/102/110/134/142/151/159 | |
| 802.11ax-HE80 | | HE0 | 42/58/106/122/138/155 | |
| 802.11ax-HE160 | HE0 | 50/114 | | |

| Item | | Mode | Data Rate | RU Configuration | Test Channel |
|---------------------|----------------------|----------------|-----------|------------------|--------------|
| Conducted Test Case | 26dB/6dB Bandwidth | 802.11ax-HE20 | HE0 | 26/0 | 36/100/149 |
| | | | | 52/37 | |
| | | | | 106/53 | |
| | | | HE0 | 26/8 | 64/140/165 |
| | | | | 52/40 | |
| | | | | 106/54 | |
| | | 802.11ax-HE40 | HE0 | 242/61 | 38/102/151 |
| | | | HE0 | 242/62 | 62/134/159 |
| | | 802.11ax-HE80 | HE0 | 484/65 | 42/106/155 |
| | | | HE0 | 484/66 | 58/122/155 |
| | | 802.11ax-HE160 | HE0 | 996/67 | 50/114 |
| | | | HE0 | 996/S67 | 50/114 |
| Conducted Test Case | Maximum output power | 802.11ax-HE20 | HE0 | 26/0 | 36/100/149 |
| | | | | 52/37 | |
| | | | | 106/53 | |
| | | | HE0 | 26/8 | 64/140/165 |
| | | | | 52/40 | |
| | | | | 106/5 | |
| | | 802.11ax-HE40 | HE0 | 242/61 | 38/102/151 |
| | | | HE0 | 242/62 | 62/134/159 |
| | | 802.11ax-HE80 | HE0 | 484/65 | 42/106/155 |
| | | | HE0 | 484/66 | 58/122/155 |
| | | 802.11ax-HE160 | HE0 | 996/67 | 50/114 |
| | | | HE0 | 996/S67 | 50/114 |

| Item | | Mode | Data Rate | RU Configuration | Test Channel |
|---------------------|------------------------|----------------|-----------|------------------|--------------|
| Conducted Test Case | Power spectral density | 802.11ax-HE20 | HE0 | 26/0 | 36/100/149 |
| | | | | 52/37 | |
| | | | | 106/53 | |
| | | | HE0 | 26/8 | 64/140/165 |
| | | | | 52/40 | |
| | | | | 106/54 | |
| | | 802.11ax-HE40 | HE0 | 242/61 | 38/102/151 |
| | | | HE0 | 242/62 | 62/134/159 |
| | | 802.11ax-HE80 | HE0 | 484/65 | 42/106/155 |
| | | | HE0 | 484/66 | 58/122/155 |
| | | 802.11ax-HE160 | HE0 | 996/67 | 50/114 |
| | | | HE0 | 996/S67 | 50/114 |

Note 1: Mobile Device

Portable Device, and 3 axis were assessed. The worst scenario for Radiated Spurious Emission as follow: Lie Side Stand

Note 2: Low, mid, and high channels were measured, only the worst channel of each modulation was presented in this report.

Note 3: Both of the antennas are the same type, and we presented the worst case in the report. The max-gain condition with SISO (main port) and MIMO is SKU 1. The MIMO is uncorrelated and supported SDM mode only.

Note 4: The modulation and bandwidth are similar for 802.11n mode for HT20/HT40 and 802.11ac mode for VHT20/VHT40, therefore investigated worst case to representative mode in the test report.

Note 5: The data rates were selected based on preliminary testing that identified rate as the worst case for output power.

3.7. Output Power Setting

| Mode | U-NII Band | Centre Frequency (MHz) | Power Setting | |
|---------|------------|------------------------|---------------|----------------|
| | | | Chain 0 (AUX) | Chain 1 (Main) |
| 802.11a | I | 5180 | 18.00 | 18.00 |
| | | 5200 | 18.75 | 18.75 |
| | | 5240 | 19.38 | 19.38 |
| | 2A | 5260 | 19.13 | 19.13 |
| | | 5300 | 19.00 | 19.00 |
| | | 5320 | 18.50 | 18.00 |
| | 2C | 5500 | 18.50 | 18.50 |
| | | 5580 | 20.00 | 20.00 |
| | | 5700 | 17.68 | 18.75 |
| | | 5720 | 20.00 | 20.00 |
| | III | 5745 | 20.00 | 20.25 |
| | | 5785 | 20.00 | 20.50 |
| 5825 | | 20.00 | 20.00 | |

| Mode | U-NII Band | Centre Frequency (MHz) | Power Setting | Mode | U-NII Band | Centre Frequency (MHz) | Power Setting |
|------------------|------------|------------------------|---------------|-------------------|------------|------------------------|---------------|
| 802.11n- HT20 | I | 5180 | 15.00 | 802.11ax- HE20 | I | 5180 | 15.38 |
| | | 5200 | 15.75 | | | 5200 | 16.13 |
| | | 5240 | 16.25 | | | 5240 | 16.50 |
| | 2A | 5260 | 16.25 | | 2A | 5260 | 16.38 |
| | | 5300 | 16.25 | | | 5300 | 16.38 |
| | | 5320 | 15.13 | | | 5320 | 15.38 |
| | 2C | 5500 | 15.50 | | 2C | 5500 | 16.00 |
| | | 5580 | 17.25 | | | 5580 | 17.25 |
| | | 5700 | 14.75 | | | 5700 | 15.00 |
| | | 5720 | 17.25 | | | 5720 | 17.50 |
| | III | 5745 | 17.25 | | III | 5745 | 17.63 |
| | | 5785 | 17.25 | | | 5785 | 17.63 |
| 5825 | | 17.25 | 5825 | 17.63 | | | |

| Mode | U-NII Band | Centre Frequency (MHz) | Power Setting | Mode | U-NII Band | Centre Frequency (MHz) | Power Setting |
|------------------|------------|------------------------|---------------|-------------------|------------|------------------------|---------------|
| 802.11n- HT40 | I | 5190 | 15.25 | 802.11ax- HE40 | I | 5190 | 15.13 |
| | | 5230 | 15.88 | | | 5230 | 16.25 |
| | 2A | 5270 | 15.88 | | 2A | 5270 | 16.25 |
| | | 5310 | 14.25 | | | 5310 | 14.25 |
| | 2C | 5510 | 14.63 | | 2C | 5510 | 14.63 |
| | | 5550 | 15.50 | | | 5550 | 15.75 |
| | | 5670 | 17.00 | | | 5670 | 17.00 |
| | | 5710 | 17.50 | | | 5710 | 17.75 |
| | III | 5755 | 17.50 | | III | 5755 | 17.50 |
| | | 5795 | 17.50 | | | 5795 | 17.75 |

| Mode | U-NII Band | Centre Frequency (MHz) | Power Setting | Mode | U-NII Band | Centre Frequency (MHz) | Power Setting |
|-------------------|------------|------------------------|---------------|-------------------|------------|------------------------|---------------|
| 802.11 ac-VT80 | I | 5210 | 15.25 | 802.11ax- HE80 | I | 5210 | 15.25 |
| | 2A | 5290 | 14.25 | | 2A | 5290 | 14.00 |
| | 2C | 5530 | 15.25 | | 2C | 5530 | 15.00 |
| | | 5610 | 17.25 | | | 5610 | 17.50 |
| | | 5690 | 17.50 | | | 5690 | 17.75 |
| | III | 5775 | 16.00 | | III | 5775 | 16.00 |

| Mode | U-NII Band | Centre Frequency (MHz) | Power Setting | Mode | U-NII Band | Centre Frequency (MHz) | Power Setting |
|------------------------|------------|------------------------|---------------|--------------------|------------|------------------------|---------------|
| 802.11 ac- VT160 | I/2A | 5250 | 10.63 | 802.11ax- HE160 | I/2A | 5250 | 10.63 |
| | 2C | 5570 | 10.25 | | 2C | 5570 | 10.25 |

| Mode | U-NII Band | Centre Frequency (MHz) | RU Configuration | Power Setting |
|----------------|------------|------------------------|------------------|---------------|
| 802.11ax-HE20 | I | 5180 | 26/0 | 11.25 |
| | | | 52/37 | 14.13 |
| | | | 106/53 | 14.63 |
| | 2A | 5320 | 26/8 | 11.63 |
| | | | 52/40 | 11.63 |
| | | | 106/54 | 14.50 |
| | 2C | 5500 | 26/0 | 11.88 |
| | | | 52/37 | 14.75 |
| | | | 106/53 | 15.88 |
| | | 5700 | 26/8 | 12.00 |
| | | | 52/40 | 12.88 |
| | | | 106/54 | 14.25 |
| | III | 5745 | 26/0 | 11.00 |
| | | | 52/37 | 14.00 |
| | | | 106/53 | 17.00 |
| 5825 | | 26/8 | 15.00 | |
| | | 52/40 | 16.75 | |
| | | 106/54 | 16.75 | |
| 802.11ax-HE40 | I | 5190 | 242/61 | 15.00 |
| | 2A | 5310 | 242/62 | 13.50 |
| | 2C | 5510 | 242/61 | 14.50 |
| | | 5670 | 242/62 | 17.00 |
| | III | 5755 | 242/61 | 17.00 |
| | | 5795 | 242/62 | 16.88 |
| 802.11ax-HE80 | I | 5210 | 484/65 | 15.00 |
| | 2A | 5290 | 484/66 | 11.38 |
| | 2C | 5530 | 484/65 | 13.50 |
| | | 5610 | 484/66 | 15.88 |
| | III | 5775 | 484/65 | 15.50 |
| | | | 484/66 | 15.25 |
| 802.11ax-HE160 | I/ 2A | 5250 | 996/67 | 9.88 |
| | | | 996/S67 | 9.63 |
| | 2C | 5570 | 996/67 | 9.38 |
| | | | 996/S67 | 9.50 |

3.8. Tested Supporting System List

3.8.1. Support Peripheral Unit

| No. | Product | Brand | Model No. | Serial No. | Approval |
|-----------------------|-------------|--------|-----------------|------------|---|
| 1. | LCD Monitor | DELL | U2718Qb | N/A | N/A |
| 2. | USB Mouse | Beauty | A11 | N/A | FCC By DoC |
| 3. | Earphone | APPLE | N/A | N/A | N/A |
| 4. | SD Card | ADATA | Micro SDHC Card | N/A | N/A |
| Partner System | | | | | |
| 5. | AP Server | ASUS | RT-AX88U | N/A | FCC ID: MSQ-RTAXHP00 IC: 3568A-RTAXHP00 |

3.8.2. Cable Lists

| No. | Cable Description Of The Above Support Units |
|-----|--|
| 1. | HDMI Cable: Shielded, Detachable, 1.8m AC Power Cord: Unshielded, Detachable, 1.8m |
| 2. | USB Cable: Unshielded, Undetachable, 1.8m |
| 3. | Earphone Cable: Unshielded, Undetachable, 0.9m |
| 4. | N/A |
| 5. | AC Power Cord: Unshielded, Detachable, 1.8m LAN cable: Unshielded, Detachable, 3.0m |

3.9. Setup Configuration

3.9.1. EUT Configuration for Power Line & Radiated Emission

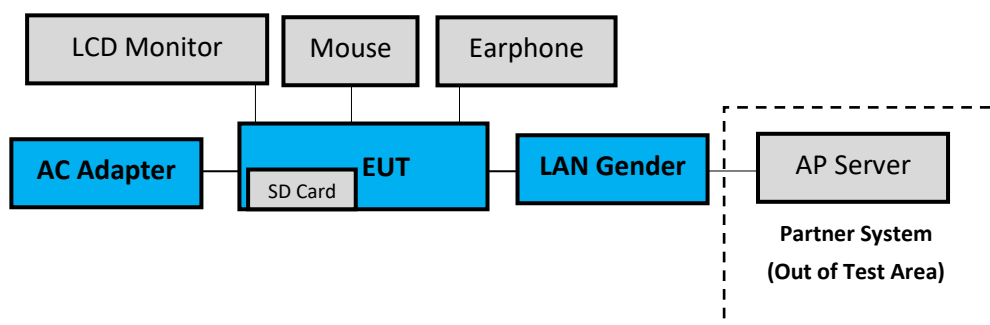

3.9.2. EUT Configuration for RF Conducted Test Items

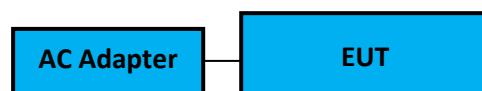

3.10. Operating Condition of EUT

Test program “DRTU” is used for enabling EUT WLAN function under continues transmitting and choosing data rate/ channel.

[Chain 0 is aux port (A Button in DRTU) Chain 1 is main port (B Button in DRTU)].

3.11. Description of Test Facility

| | |
|-------------------|--|
| Name of Test Firm | Audix Technology Corporation / EMC Department No. 491, Zhongfu Rd., Linkou Dist., New Taipei City 244, Taiwan Tel: +886-2-26092133 Fax: +886-2-26099303 Website : www.audixtech.com Contact e-mail: attemc_report@audixtech.com |
| Accreditations | The laboratory is accredited by following organizations under ISO/IEC 17025:2017 (1) NVLAP(USA) NVLAP Lab Code 200077-0 (2) TAF(Taiwan) No. 1724 |
| Test Facilities | FCC OET Designation Number under APEC MRA by NCC is : TW1724 ISED CAB Identifier Number under APEC TEL MRA by NCC is TW1724 (1) No.8 Shielded Room (2) No.5 3m Semi Anechoic Chamber (3) Fully Anechoic Chamber |

3.12.Measurement Uncertainty

| Test Items/Facilities | | Frequency Range | Uncertainty |
|--|---|--------------------------------|-------------|
| Conduction Test | | 9kHz-150kHz | ±3.7dB |
| | | 150kHz-30MHz | ±3.4dB |
| Radiation Test | <input type="checkbox"/> No.1 3m Semi Anechoic Chamber | 30MHz-200MHz, 3m, Horizontal | ±3.8dB |
| | | 200MHz-1000MHz, 3m, Horizontal | ±4.1dB |
| | | 30MHz-200MHz, 3m, Vertical | ±4.5dB |
| | | 200MHz-1000MHz, 3m, Vertical | ±4.5dB |
| | | 1GHz-6GHz, 3m | ±4.7dB |
| | | 6GHz-18GHz, 3m | ±4.1dB |
| | <input type="checkbox"/> No.3 3m Semi Anechoic Chamber | 30MHz-200MHz, 3m, Horizontal | ±3.9dB |
| | | 200MHz-1000MHz, 3m, Horizontal | ±4.2dB |
| | | 30MHz-200MHz, 3m, Vertical | ±4.3dB |
| | | 200MHz-1000MHz, 3m, Vertical | ±4.5dB |
| | <input type="checkbox"/> No.4 3m Semi Anechoic Chamber | 30MHz-200MHz, 3m, Horizontal | ±4.1dB |
| | | 200MHz-1000MHz, 3m, Horizontal | ±4.5dB |
| | | 30MHz-200MHz, 3m, Vertical | ±4.4dB |
| | | 200MHz-1000MHz, 3m, Vertical | ±4.8dB |
| | | 1GHz-6GHz, 3m | ±5.0dB |
| | | 6GHz-18GHz, 3m | ±4.7dB |
| | <input checked="" type="checkbox"/> No.5 3m Semi Anechoic Chamber | 30MHz-200MHz, 3m, Horizontal | ±4.2dB |
| | | 200MHz-1000MHz, 3m, Horizontal | ±4.3dB |
| | | 30MHz-200MHz, 3m, Vertical | ±4.3dB |
| | | 200MHz-1000MHz, 3m, Vertical | ±4.7dB |
| 1GHz-6GHz, 3m | | ±4.8dB | |
| 6GHz-18GHz, 3m | | ±4.5dB | |
| <input checked="" type="checkbox"/> Fully Anechoic Chamber | 30MHz~1000MHz | ±4.6dB | |
| | 1GHz~18GHz | ±5.4dB | |
| | 18GHz~40GHz | ±3.52dB | |
| | 40GHz~260GHz | ±3.56dB | |

Remark : Uncertainty = $ku_c(y)$

| Test Items | Uncertainty |
|------------------------|-------------|
| Emission Bandwidth | ± 0.2kHz |
| Maximum output power | ± 0.33dB |
| Power spectral density | ± 0.13dB |

4. MEASUREMENT EQUIPMENT LIST

4.1. Conducted Emission Measurement

| Item | Type | Manufacturer | Model No. | Serial No. | Cal. Date | Cal. Interval |
|------|----------------------------|--------------|-----------|------------|--------------|---------------|
| 1. | Test Receiver | R&S | ESR3 | 101774 | 2021. 02. 02 | 1 Year |
| 2. | A.M.N. | R&S | ENV432 | 101567 | 2021. 04. 21 | 1 Year |
| 3. | L.I.S.N. | Kyoritsu | KNW-407 | 8-855-9 | 2020. 12. 10 | 1 Year |
| 4. | Pulse Limiter | R&S | ESH3-Z2 | 100354 | 2021. 01. 04 | 1 Year |
| 5. | Digital Thermo-Hygro Meter | iMax | HTC-1 | No.8 S/R | 2021. 04. 15 | 1 Year |
| 6. | Coaxial Cable | Yeida | RG/58AU | CE-08 | 2020. 09. 19 | 1 Year |
| 7. | Test Software | Audix | e3 | V6.120619c | N.C.R. | N.C.R. |

4.2. Radiated Emission Measurement

| Item | Type | Manufacturer | Model No. | Serial No. | Cal. Date | Cal. Interval |
|------|----------------------------|------------------------------|--------------|-------------|--------------|---------------|
| 1. | Spectrum Analyzer | Keysight | N9010B-544 | MY55460198 | 2021. 04. 14 | 1 Year |
| 2. | Spectrum Analyzer | Agilent | N9030A-526 | MY53310269 | 2021. 01. 14 | 1 Year |
| 3. | Test Receiver | R&S | ESR7 | 101967 | 2020. 10. 29 | 1 Year |
| 4. | Amplifier | Sonoma | 310N | 187158 | 2021. 02. 19 | 1 Year |
| 5. | Microwave Preamplifier | Agilent | 8449B | 3008A02678 | 2021. 02. 19 | 1 Year |
| 6. | Microwave Amplifier | Keysight | 83051A | MY53010042 | 2020. 08. 05 | 1 Year |
| 7. | Microwave Amplifier | Agilent | 8449B | 3008A02678 | 2021. 02. 27 | 1 Year |
| 8. | Loop Antenna | R&S | HFH2-Z2 | 891847/27 | 2019. 12. 26 | 2 Years |
| 9. | TRILOG Broad band antenna | Schwarzbeck | VULB 9168 | 862 | 2021. 01. 15 | 1 Year |
| 10. | Horn Antenna | ETS-Lindgren | 3117 | 00135902 | 2021. 03. 19 | 1 Year |
| 11. | Horn Antenna | COM-POWER | AH-840 | 101092 | 2021. 01. 05 | 1 Year |
| 12. | 5G Notch Filter | Microwave Circuits | N0452502 | 459775 | 2020. 05. 06 | 1 Year |
| 13. | 5G Notch Filter | Microwave Circuits | N0555983 | 504921 | 2020. 08. 05 | 1 Year |
| 14. | 5G Notch Filter | Microwave Circuits | N0257881 | 459776 | 2020. 08. 20 | 1 Year |
| 15. | Coaxial Cable | Yeida | CFD400-E | RE-19 | 2021. 01. 29 | 1 Year |
| 16. | Coaxial Cable | HUBER+SUHNER | SUCOFLEX 104 | RE-29 | 2020. 09. 19 | 1 Year |
| 17. | Coaxial Cable | HUBER+SUHNER | SUCOFLEX 102 | RE-30 | 2020. 09. 19 | 1 Year |
| 18. | Digital Thermo-Hygro Meter | iMax | HTC-1 | No.5 3m A/C | 2021. 04. 15 | 1 Year |
| 19. | Digital Thermo-Hygro Meter | Shenzhen Datronn Electronics | KT-905 | RF | 2021. 04. 15 | 1 Year |
| 20. | Test Software | Audix | e3 | V9.20170603 | N.C.R. | N.C.R. |
| 21. | Test Software | Audix | e3 | V6.110601 | N.C.R. | N.C.R. |

4.3. RF Conducted Measurement

| Item | Type | Manufacturer | Model No. | Serial No. | Cal. Date | Cal. Interval |
|------|----------------------------|--------------|------------|------------|--------------|---------------|
| 1. | Spectrum Analyzer | Keysight | N9020B-544 | MY57120357 | 2021. 01. 06 | 1 Year |
| 2. | Power Meter | Anritsu | ML2487A | 6K00005406 | 2021. 04. 28 | 1 Year |
| 3. | Power Sensor | Anritsu | MA2491A | 030873 | 2021. 04. 28 | 1 Year |
| 4. | Digital Thermo-Hygro Meter | iMax | HTC-1 | RF-03 | 2021. 04. 15 | 1 Year |

5. CONDUCTED EMISSION

5.1. Block Diagram of Test Setup

5.1.1. Block Diagram of EUT

Indicated as section 3.9

5.1.2. Shielded Room Setup Diagram

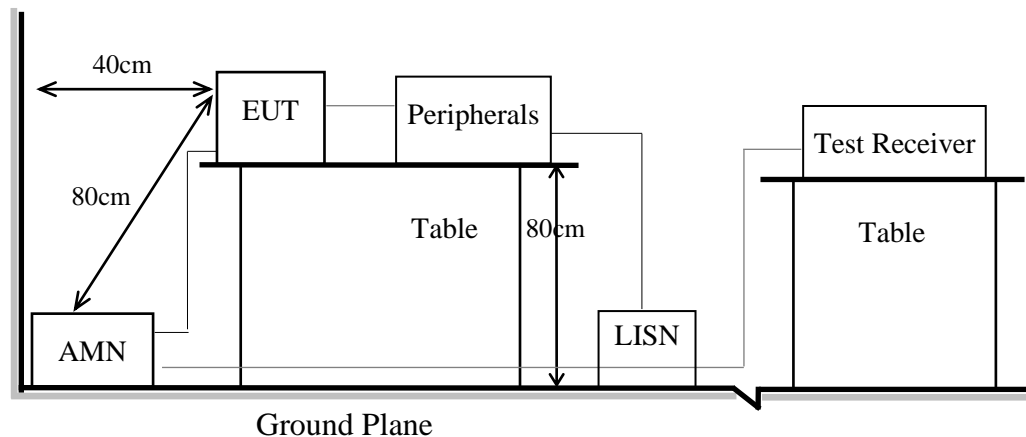

5.2. Conducted Emission Limit

| Frequency | Conducted Limit | |
|-----------------|--------------------|--------------------|
| | Quasi-Peak Level | Average Level |
| 150kHz ~ 500kHz | 66 ~ 56 dB μ V | 56 ~ 46 dB μ V |
| 500kHz ~ 5MHz | 56 dB μ V | 46 dB μ V |
| 5MHz ~ 30MHz | 60 dB μ V | 50 dB μ V |

Remark1.: If the average limit is met when using a Quasi-Peak detector, the measurement using the average detector is not required.

2.: The lower limit applies to the band edges.

5.3. Test Procedure

- 5.3.1. To set up the EUT as indicated in ANSI C63.10. The EUT was placed on the table which has 80 cm height to the ground and 40 cm distance to the conducting wall.
- 5.3.2. Power supplier of the EUT was connected to the AC mains through an Artificial Mains Network (A.M.N.).
- 5.3.3. The AC power supplies to all peripheral devices must be provided through line impedance stabilization network (L.I.S.N.)
- 5.3.4. Checking frequency range from 150kHz to 30 MHz and record the emission which does not have 20 dB below limit.



Audix Technology Corp.
No. 491, Zhongfu Rd., Linkou Dist.,
New Taipei City 244, Taiwan

Tel: +886 2 26099301
Fax: +886 2 26099303

5.4. Test Results

Please refer to Appendix A.

6. RADIATED EMISSION

6.1. Block Diagram of Test Setup

6.1.1. Block Diagram of EUT

Indicated as section 3.9

6.1.2. Setup Diagram for 9kHz-30MHz

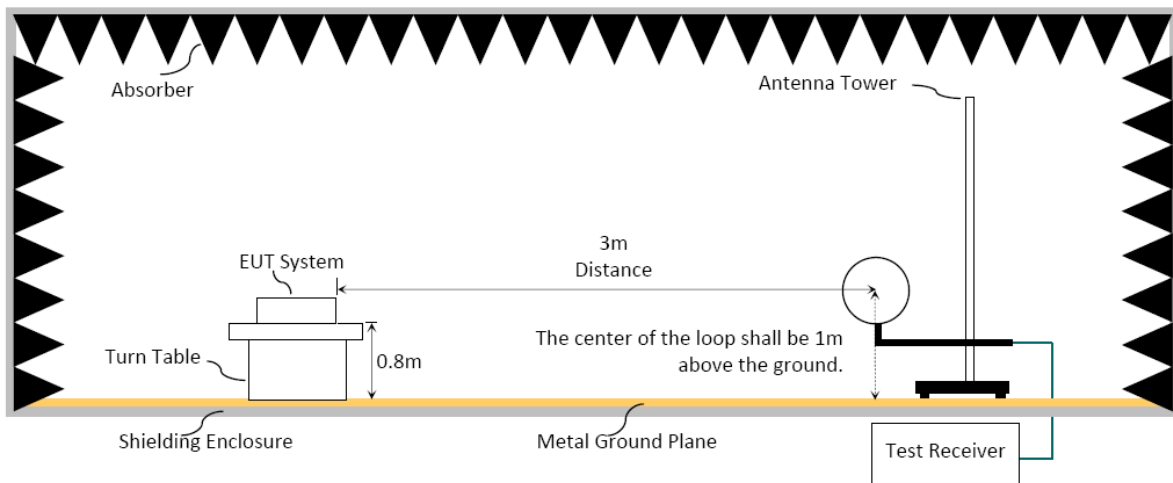

6.1.3. Setup Diagram for 30-1000MHz

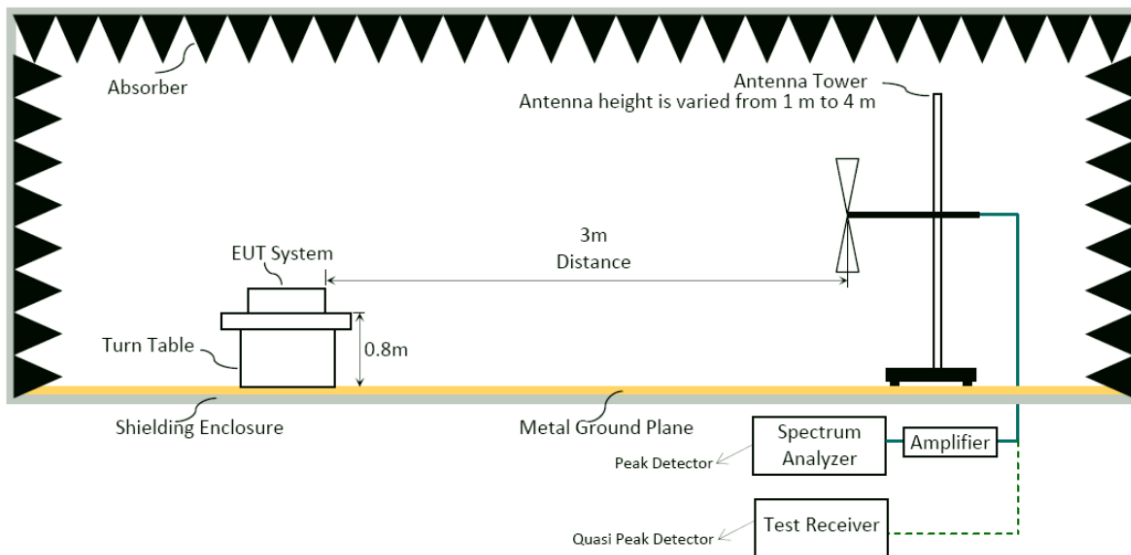

6.1.4. Setup Diagram for above 1GHz

Fully Anechoic Chamber

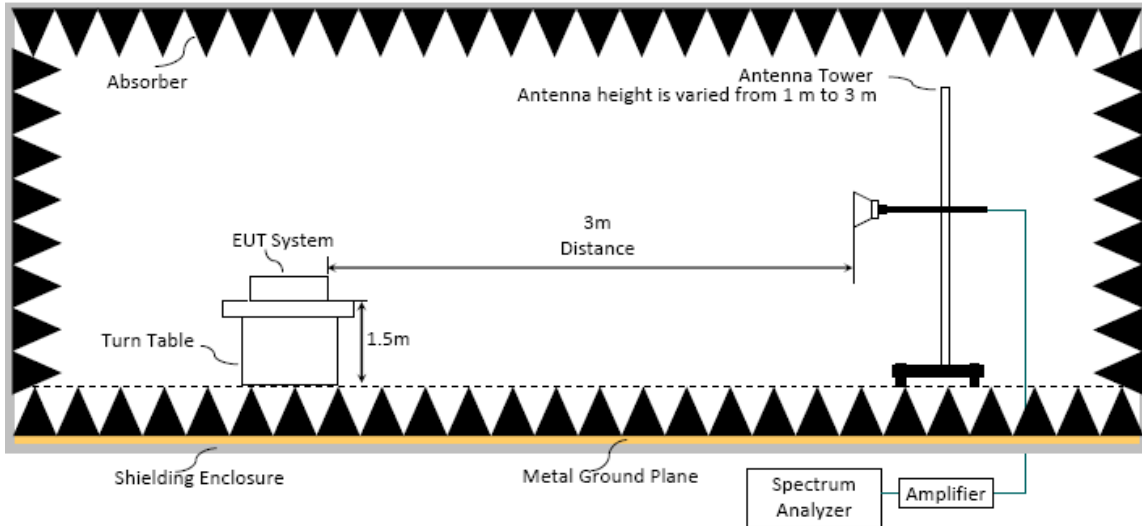

Semi Anechoic Chamber

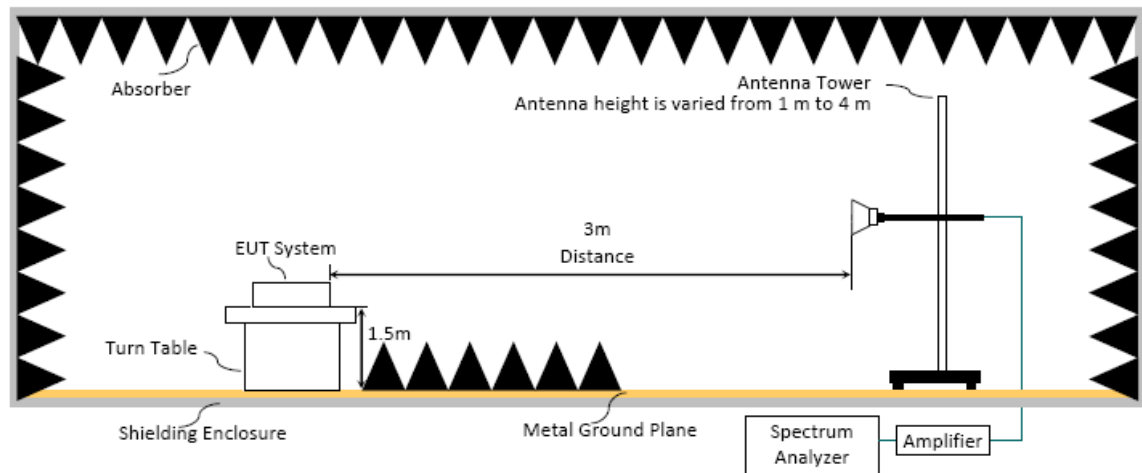

6.2. Radiated Emission Limits

Radiated emissions fall in restricted bands, as defined in Section 15.205 must be in compliance with the radiated emission limits specified in 15.209 as below.

6.2.1. General Limit

| Frequency (MHz) | Distance(m) | Limits | |
|-----------------|-------------|---|-------------|
| | | dB μ V/m | μ V/m |
| 0.009 - 0.490 | 300 | 67.6-20 log f(kHz) | 2400/f kHz |
| 0.490 - 1.705 | 30 | 87.6-20 log f(kHz) | 24000/f kHz |
| 1.705 - 30 | 30 | 29.5 | 30 |
| 30 - 88 | 3 | 40.0 | 100 |
| 88- 216 | 3 | 43.5 | 150 |
| 216- 960 | 3 | 46.0 | 200 |
| Above 960 | 3 | 54.0 | 500 |
| Above 1000 | 3 | 74.0 dB μ V/m (Peak) 54.0 dB μ V/m (Average) | |

Remark : (1) dB μ V/m = 20 log (μ V/m)

(2) The tighter limit applies to the edge between two frequency bands.

(3) Distance refers to the distance in meters between the measuring instrument antenna and the closed point of any part of the device or system.

(4) Fundamental and emission fall within operation band are exempted from this section.

(5) Pursuant to ANSI C63.10: 6.6.4.3, if the maximized peak measured value complies with the average limit, then it is unnecessary to perform an average measurement.

6.2.2. Limit for non-restricted frequency above 1 GHz

| Frequency Band (MHz) | E.I.R.P. Limit | Field Strength Limit at 3 m |
|----------------------|----------------|-----------------------------|
| 5150 to 5250 | -27 dBm | 68.2 |
| 5250 to 5350 | | 68.2 |
| 5470 to 5725 | | 68.2 |

Note: Field Strength at 3 m= E.I.R.P. + 95.2 dB

| Frequency Band (MHz) | Field Strength Limit at 3 m |
|----------------------|--|
| 5725 to 5850 | <input checked="" type="checkbox"/> 15.407(b)(4)(i) All emissions shall be limited to a level of 68.2 dB μ V/mat 75 MHz or more above or below the band edge increasing linearly to 105.2dB μ V/m at 25 MHz above or below the band edge, and from 25 MHz above or below the band edge increasing linearly to a level of 110.8 dB μ V/m at 5 MHz above or below the band edge increasing linearly to a level of 68.2 dB μ V/m at the band edge. |
| | <input type="checkbox"/> 15.407(b)(4)(ii) ,compliance with the emission limits in § 15.247(d) Shall be at least 30dB below that in the 100 kHz bandwidth within the band that contains the highest level of the desired power,. Attenuation below the general limits specified in §15.209(a) is not required. In addition,radiated emissions which fall in the restricted bands, as defined in §15.205(a), must also comply with the radiated emission limits specified in §15.209(a) (see §15.205(c)) |

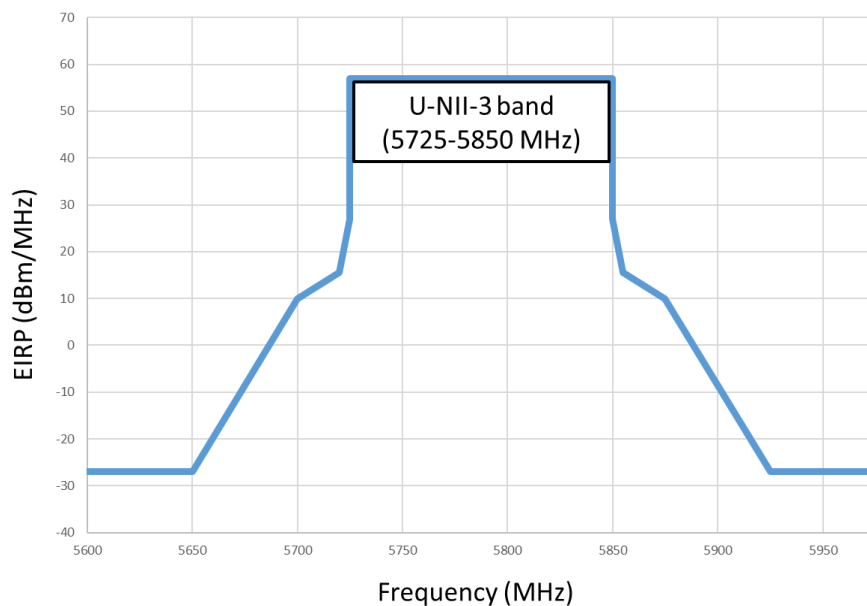

6.3. Test Procedure

Frequency Range 9kHz~30MHz:

The EUT setup on the turntable which has 0.8 m height to the ground. The turn table rotated 360 degrees and antenna fixed to 1 m to find the maximum emission level. In order to find the maximum emission, all of the interface cables were manipulated according to ANSI C63.10-2013 regulation.

- (1) RBW = 9kHz with peak and average detector.
- (2) Detector: average and peak (9kHz-490kHz)
Q.P. (490kHz-30MHz)

Frequency Range 30MHz ~ 40GHz:

The EUT setup on the turn table which has 80cm (for 30-1000MHz) and 1.5m (for above 1GHz) height to the ground. The turn table rotated 360 degrees and antenna varied from 1 m to 4 m (for 30-1000MHz) and from 1m to 3m (for above 1GHz at fully Anechoic Chamber) or from 1 m to 4 m (for above 1GHz at Semi Anechoic Chamber) to find the maximum emission level. Both horizontal and vertical polarization are required. In order to find the maximum emission, all of the interface cables were manipulated according to ANSI C63.10-2013 regulation.

Frequency below 1GHz:

Spectrum Analyzer is used for pre-testing with following setting:

- (1) RBW = 120kHz
- (2) VBW $\geq 3 \times$ RBW.
- (3) Detector = Peak.
- (4) Sweep time = auto.
- (5) Trace mode = max hold.
- (6) Allow sweeps to continue until the trace stabilizes.

Note 1: When peak-detected value is lower than limit that the measurement using the Q.P. detector is not required, otherwise using Q.P. for final measurement.

Note 2: When the radiated emissions limits are expressed in terms of the average value of the emissions, and pulsed operation is employed, the measurement field strength shall be determined by averaging over one complete pulse train, including blanking intervals, as long as the pulse train does not exceed 0.1 seconds.

Frequency above 1GHz to 10th harmonic (up to 40 GHz):

Peak Detector:

- (1) RBW = 1MHz
- (2) VBW $\geq 3 \times$ RBW.
- (3) Detector = Peak.
- (4) Sweep time = auto.
- (5) Trace mode = max hold.
- (6) Allow sweeps to continue until the trace stabilizes.

Note: When peak-detected value is lower than limit that the measurement using the average detector is not required, otherwise using average detector for final measurement.

Average Detector:

Option 1:

- (1) RBW = 1MHz
- (2) VBW \geq 1/ T.

| Modulation Type | T (ms) | 1/ T (kHz) | VBW Setting(kHz) |
|-----------------|--------|------------|------------------|
| 802.11a | 2.087 | 0.479 | 10Hz |
| 802.11n-HT20 | 3.980 | 0.251 | 10Hz |
| 802.11n-HT40 | 3.980 | 0.251 | 10Hz |
| 802.11ac-VHT80 | 3.960 | 0.253 | 10Hz |
| 802.11ac-VHT160 | 2.780 | 0.360 | 10Hz |
| 802.11ax-HE20 | 3.970 | 0.252 | 10Hz |
| 802.11ax-HE40 | 3.970 | 0.252 | 10Hz |
| 802.11ax-HE80 | 3.980 | 0.251 | 10Hz |
| 802.11ax-HE160 | 2.280 | 0.439 | 10Hz |

N/A: 1/ T is not implemented when duty cycle presented in section 3.6 is \geq 98%.

- (1) Detector = Peak.
- (2) Sweep time = auto.
- (3) Trace mode = max hold.
- (4) Allow sweeps to continue until the trace stabilizes.

Option 2:

Average Emission Level= Peak Emission Level+ D.C.C.F.

6.4. Measurement Result Explanation

- Peak Emission Level=Antenna Factor + Cable Loss + Meter Reading (including Preamp factor if test used)
- Average Emission Level l=Antenna Factor + Cable Loss + Meter Reading (including Preamp factor if test used)
- Average Emission Level= Peak Emission Level+ DCCF
 Duty Cycle Correction Factor (DCCF)= $20\log(TX_{on}/TX_{on+off})$ presented in section 3.6.
- ERP= Peak Emission Level-95.2dB-2.14dB

6.5. Test Results

Please refer to Appendix A.

7. 26dB/6dB BANDWIDTH

7.1. Block Diagram of Test Setup

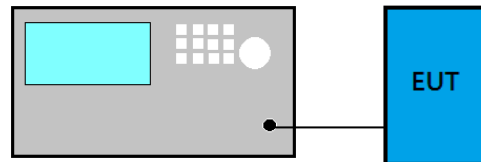

7.2. Specification Limits

| Frequency Band (MHz) | Limit |
|----------------------|----------------------|
| 5150 to 5250 | Reference only |
| 5250 to 5350 | |
| 5470 to 5725 | |
| 5725 to 5850 | $\geq 500\text{kHz}$ |

7.3. Test Procedure

Following measurement procedure is reference to KDB 789033 D02 General UNII Test Procedures New Rules v02r01:

■ Applicable to all bands except to 5725 MHz- 5850 MHz

- (1) Set RBW= 1% of the emission bandwidth
- (2) Set VBW > RBW
- (3) Detector = Peak
- (4) Trace mode = max hold
- (5) Setting channel bandwidth function x dB to -26 dB to record the final bandwidth.

■ 5725 MHz- 5850 MHz

- (1) Set RBW = 100 kHz.
- (2) Set the video bandwidth (VBW) $\geq 3 \times$ RBW.
- (3) Detector = Peak.
- (4) Trace mode = max hold.
- (5) Sweep = auto couple.
- (6) Allow the trace to stabilize.
- (7) Setting channel bandwidth function x dB to -6 dB to record the final bandwidth.

7.4. Test Results

Please refer to Appendix A

8. MAXIMUM OUTPUT POWER

8.1. Block Diagram of Test Setup

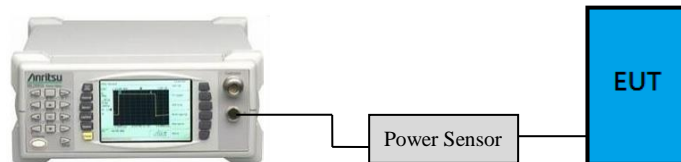

- For 802.11ac-VHT80/160, 802.11ax-HE160 modes only

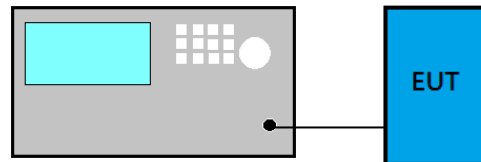

8.2. Specification Limits

| Frequency Band (MHz) | Category | Limit |
|----------------------|-----------------------------------|---|
| 5150 to 5250 | Outdoor Access Point | 1 W(30 dBm)/ Max e.i.r.p. ≤125 mW(21 dBm) at any elevation angle above 30 degrees as measured from the horizon |
| | Fixed point-to-point Access Point | 1 W(30 dBm) |
| | Indoor Access Point | 1 W(30 dBm) |
| | Mobile and Portable client device | 250 mW(24 dBm) |
| 5250 to 5350 | N/A | 250 mW or 11 dBm + 10 log B ^{Note1} |
| 5470 to 5725 | | 250 mW or 11 dBm + 10 log B ^{Note1} |
| 5725 to 5850 | | 1 W(30 dBm) |

Note 1: B is the 26 dB emission bandwidth, which presented in section 7 and appendix A.1.

8.3. Test Procedure

Following measurement procedure is reference to KDB 789033 D02 General UNII Test Procedures New Rules v02r01:

■ **Method AVGPM (Measurement using an RF average power meter):**

EUT is connected to power sensor and record the maximum average output power and duty cycle factor is added when duty cycle presented in section 3.7 is < 98%.

■ **Method AVGSA-2 (Spectrum channel power) for 802.11ac-VHT80/160, 802.11ax-HE80/160 modes only**

- (1) Set span to at least 1.5 times the OBW
- (2) Set RBW = 1 MHz
- (3) Set the video bandwidth (VBW) \geq 3 MHz.
- (4) Detector = RMS.
- (5) Trace mode = trace average at least 100 traces
- (6) Sweep = auto couple.
- (7) Compute power by integrating the spectrum across the OBW of the signal using the instrument's band power measurement function with band limits set equal to the OBW band edges.
- (8) Duty cycle factor is added when duty cycle presented in section 3.6 is < 98%.

8.4. Test Results

Please refer to Appendix A

9. POWER SPECTRAL DENSITY

9.1. Block Diagram of Test Setup

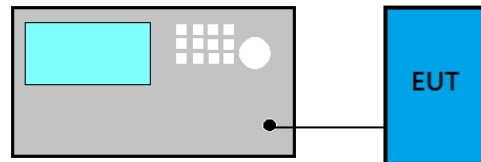

9.2. Specification Limits

| Frequency Band (MHz) | Category | Limit |
|----------------------|-----------------------------------|---------------|
| 5150 to 5250 | Outdoor Access Point | 17dBm/MHz |
| | Fixed point-to-point Access Point | |
| | Indoor Access Point | |
| | Mobile and Portable client device | 11 dBm/MHz |
| 5250 to 5350 | N/A | 11 dBm/MHz |
| 5470 to 5725 | | 11 dBm/MHz |
| 5725 to 5850 | | 30dBm/500 kHz |

9.3. Test Procedure

Following measurement procedure is reference to KDB 789033 D02 General UNII Test Procedures New Rules v02r01:

■ Method AVGSA-2 (Spectrum channel power)

- (1) Set span to at least 1.5 times the OBW
- (2) Set RBW = 1 MHz
- (3) Set the video bandwidth (VBW) \geq 3 MHz.
- (4) Detector = RMS.
- (5) Trace mode = trace average at least 100 traces
- (6) Sweep = auto couple.
- (7) Use peak search function to find out the maximum power density.
- (8) Duty cycle factor is added when duty cycle presented in section 3.6 is $<$ 98%.

9.4. Test Results

Please refer to Appendix A

10. FREQUENCY STABILITY

10.1. Block Diagram of Test Setup

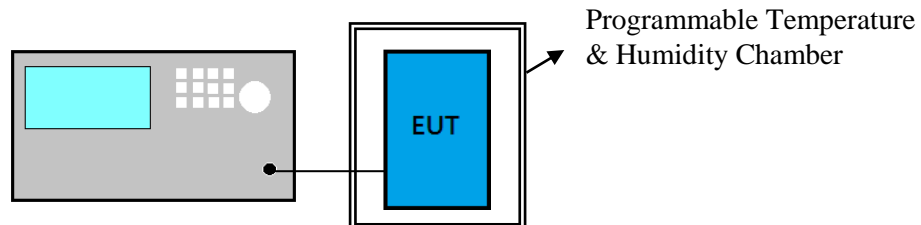

10.2. Specification Limits

NONE

10.3. Test Procedure

- (1) Frequency: Test frequency.
- (2) Span: enough to cover the complete power envelope
- (3) RBW: 1MHz(modulation ON) ; 10KHz(CW)
- (4) VBW: 1MHz(modulation ON) ; 10KHz(CW)
- (5) Detector Mode: Positive Peak
- (6) Indication mode: Max hold
- (7) Find the peak frequency and take calculate by the formula:
(Measurement Value-declaration frequency)/ declaration frequency)

10.4. Test Results

Please refer to Appendix A



11. DEVIATION TO TEST SPECIFICATIONS

【NONE】



APPDNDIX A

TEST DATA AND PLOTS

(Model: 16Z95P)



*Audix Technology Corp.
No. 53-11, Dingfu, Linkou, Dist.,
New Taipei City 244, Taiwan*

*Tel: +886 2 26099301
Fax: +886 2 26099303*

APPDNDIX B

TEST PHOTOGRAPHS

(Model: 16Z95P)