

**FCC 15.407
(Permissive Change)
WLAN 6GHz Test Report**

for

LG Electronics Inc.

**222, LG-ro, Jinwi-myeon Pyeongtaek-Si, Gyeonggi-Do,
17709 Republic of Korea**

Product Name : Notebook Computer
Model Name : (1)16Z90R (2)16ZD90R
(3)16Z90S (4)16ZD90S
Brand : LG
FCC ID : BEJNT-16Z90R

**Prepared by: : AUDIX Technology Corporation,
EMC Department**



The test report is based on a single evaluation of one sample of the above-mentioned products. It does not imply an assessment of the whole production and does not permit the use of the test lab logo.

TABLE OF CONTENTS

Description	Page
TEST REPORT.....	4
1. REVISION RECORD OF TEST REPORT	4
2. SUMMARY OF TEST RESULTS	5
3. GENERAL INFORMATION	6
3.1. Description of Application	6
3.2. Description of EUT	7
3.3. Reference Test Guidance.....	8
3.4. Information for Permissive Change.....	9
3.5. Antenna Information	10
3.6. EUT Specifications Assessed in Current Report	13
3.7. Description of Key Components	16
3.8. Test Configuration.....	19
3.9. Output Power Setting	26
3.10. Tested Supporting System List.....	28
3.11. Setup Configuration.....	28
3.12. Operating Condition of EUT	29
3.13. Description of Test Facility	29
3.14. Measurement Uncertainty	30
4. MEASUREMENT EQUIPMENTLIST.....	31
4.1. Conducted Emission Measurement	31
4.2. Radiated Emission Measurement	32
4.3. RF Conducted Measurement	32
5. CONDUCTED EMISSION.....	33
5.1. Block Diagram of Test Setup	33
5.2. Conducted Emission Limit	33
5.3. Test Procedure	33
5.4. Test Results	33
6. RADIATED EMISSION	34
6.1. Block Diagram of Test Setup	34
6.2. Radiated Emission Limits.....	36
6.3. Test Procedure	37
6.4. Measurement Result Explanation.....	39
6.5. Test Results	39
7. MAXIMUM CONDUCTED OUTPUT POWER	40
7.1. Block Diagram of Test Setup	40
7.2. Specification Limits.....	40
7.3. Test Procedure	41
7.4. Test Results	41
8. DEVIATION TO TEST SPECIFICATIONS	42

APPENDIX A TEST DATA AND PLOTS

APPENDIX B TEST PHOTOGRAPHS

TEST REPORT (Permissive Change)

Applicant : LG Electronics Inc.
Manufacturer : LG Electronics Inc.
Factory : LG Electronics Nanjing New Technology Co., Ltd.
EUT Description
(1) Product : Notebook Computer
(2) Model : (1)16Z90R (2)16ZD90R (3)16Z90S (4)16ZD90S
(3) Brand : LG
(4) Power Supply: DC 20V, 3.25A

Applicable Standards:

Title 47 FCC CFR Part 15 Subpart E

Audix Technology Corp. tested the equipment mentioned in accordance with the requirements set forth in the above standards. Test results indicate that the equipment tested is capable of demonstrating compliance with the requirements as documented within this report.

Audix Technology Corp. does not assume responsibility for any conclusions and generalizations drawn from the test results with regard to other specimens and samples.

Date of Report: 2023. 10. 11

Reviewed by:



(Annie Yu/Administrator)

Approved by:



(Johnny Hsueh/Section Manager)

1. REVISION RECORD OF TEST REPORT

Edition No	Issued Date	Revision Summary	Report Number
0	2023. 10. 11	Original Report	EM-F230461

2. SUMMARY OF TEST RESULTS

FCC Part Section(s)	Description	Results
15.207	Conducted Emission	PASS
15.205/15.209 15.407 (b)(6)	Radiated Band Edge and Radiated Spurious Emission	PASS
15.407(a)(8)	Maximum Power Spectral Density	N/A ^{Note3}
15.407(a)(8)	Maximum Conducted Output Power	PASS
2.1049 15.407(a)(10)	Emission/Occupied Bandwidth	N/A ^{Note3}
15.407(b)(6)	Undesirable emission limits: Spurious Emission (Conducted)	N/A ^{Note3}
15.407(b)(7)	In-Band Emission (Channel Mask)	N/A ^{Note3}
15.407(d)(6)	Contention Based Protocol	N/A ^{Note3}
15.203	Antenna Requirement	Compliance
Note: 1. Decision rule according to the limit of the test standard chapter, the test value is lower than the limit specified in the test chapter, and it is judged as Pass. 2. The uncertainties value is not used in determining the result. 3. Due to the difference mentioned by cover letter don't influence on RF characteristics, so it is unnecessary to re-test.		

3. GENERAL INFORMATION

3.1. Description of Application

Applicant	LG Electronics Inc. 222, LG-ro, Jinwi-myeon Pyeongtaek-Si, Gyeonggi-Do, 17709 Republic of Korea
Manufacturer	LG Electronics Inc. 222, LG-ro, Jinwi-myeon Pyeongtaek-Si, Gyeonggi-Do, 17709 Republic of Korea
Factory	LG Electronics Nanjing New Technology Co., Ltd. No.346, Yaoxin Road, Economic & Technical Development Zone, Nanjing, China.
Product	Notebook Computer
Model	(1)16Z90R (2)16ZD90R (3)16Z90S (4)16ZD90S The difference between all models is different in the sales customers, color difference and component.
Configuration (HVIN)	16Z90R-K, 16Z90R-N, 16Z90R-A, 16Z90R-R, 16Z90R-Q, 16Z90R-H, 16Z90R-T, 16Z90S-G, 16Z90S-V, 16Z90S-M, 16Z90S-C and 16Z90S-H
Brand	LG

The model 16Z90R has following different configuration and components, and the details are as follows:

Difference		Main Board	GPU	Battery	CPU	TPM (Trusted Platform Module)	Panel Touch Function	Antenna
Original	16Z90R-K	ROYAL	Intel Iris Xe	LBV7227E	Intel, i7-1360P Intel, i5-1340P	Not Support	Without	#1 WA-P-LELE-04-009 #2 L1LRF008-CS-H
	16Z90R-N	MAIN B/D	Graphics	(80 Wh)		Support		
	16Z90R-A	ROYAL	NVIDIA	LBV122CM		Not Support		
	16Z90R-R	MAIN B/D	NVIDIA GeForce RTX 3050	(90 Wh)	Support			
	16Z90R-Q	ROYAL	Intel Iris Xe	LBV7227E	Intel, i7-1370P Intel, i5-1350P	Support	With	#3 WA-P-LBLB-04-110
	16Z90R-H	ROYAL	Intel Iris Xe	LBV7227E	Intel, i7-1360P Intel, i5-1340P	Not Support		
	16Z90R-T	MAIN B/D	Graphics	(80 Wh)	Support			
This Time	16Z90S-G	MTL MAIN B/D	Intel Arc Graphics	LB3122MM (77 Wh)	Intel, Ultra 7 155H Intel, Ultra 5 125H	Not Support	Without	#1 WA-P-LELE-04-009 #2 L1LRF008-CS-H
	16Z90S-V		Intel Arc Graphics			Support		
	16Z90S-M		Intel Arc Graphics			Not Support		
	16Z90S-C		Intel Arc Graphics			Not Support		
	16Z90S-H		Intel Arc Graphics			Not Support	With	#3 WA-P-LBLB-04-110

3.2. Description of EUT

Test Model	16Z90S																													
Serial Number	N/A																													
Power Rating	DC 20V, 3.25A																													
Software Version	XY (X, Y can be 0 to 9 for different SW version not influence RF parameter)																													
RF Features	WLAN: 802.11 a/b/g/n/ac/ax Bluetooth: BT and BLE (BT 5.1)																													
Transmit Type	<table border="1" style="width: 100%;"> <thead> <tr> <th colspan="2">2.4 GHz</th> </tr> </thead> <tbody> <tr> <td>802.11b</td> <td>1T1R</td> </tr> <tr> <td>802.11g</td> <td>1T1R</td> </tr> <tr> <td>802.11n-HT20</td> <td>2T2R</td> </tr> <tr> <td>802.11n-HT40</td> <td>2T2R</td> </tr> <tr> <td>802.11ax-HE20</td> <td>2T2R</td> </tr> <tr> <td>802.11ax-HE40</td> <td>2T2R</td> </tr> <tr> <td>BT/BLE</td> <td>1T1R</td> </tr> </tbody> </table> <table border="1" style="width: 100%;"> <thead> <tr> <th colspan="2">U-NII Bands</th> </tr> </thead> <tbody> <tr> <td>802.11a</td> <td>1T1R</td> </tr> <tr> <td>802.11n-HT20/802.11ac-VHT20/802.11ax-HE20</td> <td>2T2R</td> </tr> <tr> <td>802.11n-HT40/802.11ac-VHT40/802.11ax-HE40</td> <td>2T2R</td> </tr> <tr> <td>802.11ac-VHT80/802.11ax-HE80</td> <td>2T2R</td> </tr> <tr> <td>802.11ac-VHT160/802.11ax-HE160</td> <td>2T2R</td> </tr> </tbody> </table> <p>The MIMO is uncorrelated and supported SDM(Spatial Division Multiplexing) mode only. This radio device doesn't support beamforming and Cyclic Delay Diversity (CDD).</p>		2.4 GHz		802.11b	1T1R	802.11g	1T1R	802.11n-HT20	2T2R	802.11n-HT40	2T2R	802.11ax-HE20	2T2R	802.11ax-HE40	2T2R	BT/BLE	1T1R	U-NII Bands		802.11a	1T1R	802.11n-HT20/802.11ac-VHT20/802.11ax-HE20	2T2R	802.11n-HT40/802.11ac-VHT40/802.11ax-HE40	2T2R	802.11ac-VHT80/802.11ax-HE80	2T2R	802.11ac-VHT160/802.11ax-HE160	2T2R
2.4 GHz																														
802.11b	1T1R																													
802.11g	1T1R																													
802.11n-HT20	2T2R																													
802.11n-HT40	2T2R																													
802.11ax-HE20	2T2R																													
802.11ax-HE40	2T2R																													
BT/BLE	1T1R																													
U-NII Bands																														
802.11a	1T1R																													
802.11n-HT20/802.11ac-VHT20/802.11ax-HE20	2T2R																													
802.11n-HT40/802.11ac-VHT40/802.11ax-HE40	2T2R																													
802.11ac-VHT80/802.11ax-HE80	2T2R																													
802.11ac-VHT160/802.11ax-HE160	2T2R																													
Device Category	<input type="checkbox"/> Outdoor Access Point <input type="checkbox"/> Fixed point-to-point Access Point <input type="checkbox"/> Indoor Access Point <input checked="" type="checkbox"/> Mobile and Portable client device																													
Test Sample	<table border="1" style="width: 100%;"> <thead> <tr> <th>Sample No.</th> <th>Test Item</th> <th>Firmware</th> </tr> </thead> <tbody> <tr> <td>01</td> <td>AC Conduction, RSE, Output Power</td> <td>N/A</td> </tr> <tr> <td>02</td> <td>AC Conduction, RSE, Output Power</td> <td>N/A</td> </tr> </tbody> </table>		Sample No.	Test Item	Firmware	01	AC Conduction, RSE, Output Power	N/A	02	AC Conduction, RSE, Output Power	N/A																			
Sample No.	Test Item	Firmware																												
01	AC Conduction, RSE, Output Power	N/A																												
02	AC Conduction, RSE, Output Power	N/A																												
Sample Status	Trial sample																													
Date of Receipt	2023. 09. 06																													
Date of Test	2023. 09. 28 ~ 10. 06																													

Interface Ports of EUT	<ul style="list-style-type: none">• One HDMI Port• Two USB Type C Ports• One Earphone Port• One Micro SD Card Slot• Two USB 3.0 Ports
Accessories Supplied	<ul style="list-style-type: none">• AC Adapter• USB C Cable• LAN Gender

Note: Pursuant ISO 17025:2017 section 7.8.2, Audix Technology Corp. does not assume responsibility for all EUT's information including RF features, transmit type, antenna information...etc are provided by customer.

3.3. Reference Test Guidance

ANSI C63.10:2013

KDB 789033 D02 v02r01, KDB 662911 D01 v02r01, KDB 987594 D02 v01r01

3.4. Information for Permissive Change

- The EUT is an addition version with original FCC ID: BEJNT-16Z90R is as following.
 - (a) To add new models 16Z90S and 16ZD90S.
 - (b) To add new Configuration (HVIN) 16Z90S-G, 16Z90S-V, 16Z90S-M, 16Z90S-C and 16Z90S-H.
 - (c) Based on original ROYAL MAIN B/D main board, the difference between ROYAL MAIN B/D main board and MTL MAIN B/D main board is refer to Cover Letter-Permissive Change. The MTL MAIN B/D main board is for new Configuration (HVIN) 16Z90S-G, 16Z90S-V, 16Z90S-M, 16Z90S-C and 16Z90S-H.
 - (d) To add new CPUs for MTL MAIN B/D main board.
 - (e) To add new Battery Pack for MTL MAIN B/D main board.
 - (f) To add new Type C cable (3A).
- The differences between this application and original's ID as clarify in following list.

Difference Configuration (HVIN)		Differences								
		Main Board	GPU	Battery	CPU	TPM (Trusted Platform Module)	Panel Touch Function	Antenna		
Original	16Z90R-K	ROYAL MAIN B/D	Intel Iris Xe Graphics	LBV7227E (80 Wh)	Intel, i7-1360P Intel, i5-1340P	Not Support	Without	#1 WA-P-LELE-04-009 #2 L1LRF008-CS-H		
	16Z90R-N					Support				
	16Z90R-Q	ROYAL MAIN B/D	Intel Iris Xe Graphics	LBV7227E (80 Wh)	Intel, i7-1370P Intel, i5-1350P	Support				
	16Z90R-H	ROYAL MAIN B/D	Intel Iris Xe Graphics	LBV7227E (80 Wh)	Intel, i7-1360P Intel, i5-1340P	Not Support			With	#3 WA-P-LBLB-04-110
	16Z90R-T					Support				
This Time	16Z90S-G	MTL MAIN B/D	Intel Arc Graphics	LB3122MM (77 Wh)	Intel, Ultra 7 155H Intel, Ultra 5 125H	Not Support	Without	#1 WA-P-LELE-04-009 #2 L1LRF008-CS-H		
	16Z90S-V		Intel Arc Graphics			Support				
	16Z90S-M		Intel Arc Graphics			Not Support				
	16Z90S-C		Intel Arc Graphics			Not Support				
	16Z90S-H		Intel Arc Graphics			Not Support	With	#3 WA-P-LBLB-04-110		

- Due to above different item, there have some test item should be re-tested (see section 2), the test data are recorded in this report.

3.5. Antenna Information

No.	Antenna Part Number	Manufacture	Antenna Type	Frequency (MHz)	Max Gain(dBi)	
					Main	AUX
1.	WA-P-LELE-04-009	INPAQ	Mono-Pole	2400	2.2	1.9
				2450	2.3	2.4
				2500	3.1	2.3
				5150	4.2	3.6
				5400	4.2	3.7
				5850	4.0	3.5
				5925	4.3	3.5
				6525	4.2	3.5
				7125	4.1	2.3

According to KDB 662911 D01 d) ii), transmit signals are completely uncorrelated, then
 Directional gain = $10 \log[(10^{G1/10} + 10^{G2/10} + \dots + 10^{GN/10})/N_{ANT}]$ dBi

Note 1. 2.4G: Directional gain =

2400MHz: Directional gain = $10 \log[(10^{2.2/10} + 10^{1.9/10})/2] = 2.05$ dBi

2450MHz: Directional gain = $10 \log[(10^{2.3/10} + 10^{2.4/10})/2] = 2.35$ dBi

Note 2. 5G: Directional gain =

5150MHz: = $10 \log[(10^{4.2/10} + 10^{3.6/10})/2] = 3.91$ dBi

5250MHz: = $10 \log[(10^{4.2/10} + 10^{3.6/10})/2] = 3.91$ dBi

5350MHz: = $10 \log[(10^{4.2/10} + 10^{3.7/10})/2] = 3.96$ dBi

5725MHz: = $10 \log[(10^{4.0/10} + 10^{3.5/10})/2] = 3.76$ dBi

5825MHz: = $10 \log[(10^{4.0/10} + 10^{3.5/10})/2] = 3.76$ dBi

Note 3. UNII Band (WLAN 6G):

5925MHz: Directional gain = $10 \log[(10^{4.3/10} + 10^{3.5/10})/2] = 3.92$ dBi

6525MHz: Directional gain = $10 \log[(10^{4.2/10} + 10^{3.5/10})/2] = 3.86$ dBi

7125MHz: Directional gain = $10 \log[(10^{4.1/10} + 10^{2.3/10})/2] = 3.29$ dBi

We chose the antenna gain corresponding to the frequency listed on the table which is closer to center frequency of WLAN.

No.	Antenna Part Number	Manufacture	Antenna Type	Frequency (MHz)	Max Gain(dBi)	
					Main	AUX
2.	L1LRF008-CS-H	LUXSHARE-ICT	Mono-Pole	2400	6.3	0.9
				2450	5.7	1.6
				2500	2.7	3.5
				5150	-1.5	2.3
				5400	3.4	4.5
				5850	3.3	5.8
				5925	2.9	4.7
				6525	3.4	1.3
				7125	-4.9	-1.6

According to KDB 662911 D01 d) ii), transmit signals are completely uncorrelated, then
 Directional gain = $10 \log[(10^{G1/10} + 10^{G2/10} + \dots + 10^{GN/10})/N_{ANT}]$ dBi

Note 1. 2.4G: Directional gain =
 2400MHz: Directional gain = $10 \log[(10^{6.3/10} + 10^{0.9/10})/2] = 4.42\text{dBi}$
 2450MHz: Directional gain = $10 \log[(10^{5.7/10} + 10^{1.6/10})/2] = 4.11\text{dBi}$

Note 2. 5G: Directional gain =
 5150MHz: = $10 \log[(10^{-1.5/10} + 10^{2.3/10})/2] = 0.80\text{dBi}$
 5250MHz: = $10 \log[(10^{-1.5/10} + 10^{2.3/10})/2] = 0.80\text{dBi}$
 5350MHz: = $10 \log[(10^{3.4/10} + 10^{4.5/10})/2] = 3.99\text{dBi}$
 5725MHz: = $10 \log[(10^{3.3/10} + 10^{5.8/10})/2] = 4.70\text{dBi}$
 5825MHz: = $10 \log[(10^{3.3/10} + 10^{5.8/10})/2] = 4.70\text{dBi}$

Note 3. UNII Band (WLAN 6G):
 5925MHz: Directional gain = $10 \log[(10^{2.9/10} + 10^{4.7/10})/2] = 3.92\text{dBi}$
 6525MHz: Directional gain = $10 \log[(10^{3.4/10} + 10^{1.3/10})/2] = 2.48\text{dBi}$
 7125MHz: Directional gain = $10 \log[(10^{-4.9/10} + 10^{-1.6/10})/2] = -2.99\text{dBi}$

We chose the antenna gain corresponding to the frequency listed on the table which is closer to center frequency of WLAN.

No.	Antenna Part Number	Manufacture	Antenna Type	Frequency (MHz)	Gain(dBi)	
					Main	AUX
3.	WA-P-LBLB-04-110	INPAQ	Mono-Pole	2400-2500	3.1	2.9
				5150-5350	-2.1	2.8
				5470-5725	2.5	5.7
				5725-5850	5.2	5.3
				5925-6425	4.8	3.7
				6425-6525	1.0	-1.0
				6525-6875	1.6	2.8
				6875-7125	2.9	-1.4

According to KDB 662911 D01 d) ii), transmit signals are completely uncorrelated, then
 Directional gain = $10 \log[(10^{G1/10} + 10^{G2/10} + \dots + 10^{GN/10})/N_{ANT}]$ dBi
 Note : WLAN 2.4GHz: Directional gain =
 5925-6425MHz: Directional gain = $10 \log[(10^{3.7/10} + 10^{4.8/10})/2] = 4.28$ dBi
 6425-6525MHz: Directional gain = $10 \log[(10^{-1.0/10} + 10^{1.0/10})/2] = 0.11$ dBi
 6525-6875MHz: Directional gain = $10 \log[(10^{2.8/10} + 10^{1.6/10})/2] = 2.24$ dBi
 6875-7125MHz: Directional gain = $10 \log[(10^{-1.4/10} + 10^{2.9/10})/2] = 1.26$ dBi
 We chose the antenna gain corresponding to the frequency listed on the table which is closer to center frequency of WLAN.

3.6. EUT Specifications Assessed in Current Report

Mode	U-NII Band	Fundamental Range (MHz)	Channel Number
802.11ax-HE20	5	5955-6415	24
	6	6435-6515	5
	7	6535-6855	17
	8	6875-7115	13
802.11ax-HE40	5	5965-6405	12
	6	6445-6485	2
	7	6525-6845	9
	8	6885-7085	6
802.11ax-HE80	5	5985-6385	6
	6	6465-6545	2
	7	6625-6785	3
	8	6865-7025	3
802.11ax-HE160	5	6025-6345	3
	6	6505	1
	7	6665-6825	2
	8	6985	1

Mode	Modulation	Data Rate (Mbps)
802.11ax-HE20	OFDMA (BPSK/ QPSK/ 16QAM/ 64QAM/ 256QAM/1024QAM)	Up to 287
802.11ax-HE40		Up to 574
802.11ax-HE80		Up to 1201
802.11ax-HE160		Up to 2402

Channel List								
802.11ax-HE20								
U-NII Band	Channel Number	Freq. (MHz)	U-NII Band	Channel Number	Freq. (MHz)	U-NII Band	Channel Number	Freq. (MHz)
5	2	5955	5	81	6335	7	161	6755
	5	5975		85	6375		165	6775
	9	5995		89	6395		169	6795
	13	6015		93	6415		173	6815
	17	6035		97	6435		177	6835
	21	6055	6	101	6455	181	6855	
	25	6075		105	6475	185	6875	
	29	6095		109	6495	189	6895	
	33	6115		113	6515	193	6915	
	37	6135	7	117	6535	197	6935	
	41	6155		121	6555	201	6955	
	45	6175		125	6575	205	6975	
	49	6195		129	6595	209	6995	
	53	6215		133	6615	213	7015	
	57	6235		137	6635	217	7035	
	61	6255		141	6655	221	7055	
	65	6275		145	6675	225	7075	
	69	6295		149	6695	229	7095	
	73	6315		153	6715	233	7115	
	77	6335	157	6735				

Channel List								
802.11ax-HE40								
U-NII Band	Channel Number	Freq. (MHz)	U-NII Band	Channel Number	Freq. (MHz)	U-NII Band	Channel Number	Freq. (MHz)
5	3	5965	5	83	6365	7	163	6765
	11	6005		91	6405		171	6805
	19	6045		99	6445		179	6845
	27	6085	6	107	6485	187	6885	
	35	6125	7	115	6525	195	6925	
	43	6165		123	6565	203	6965	
	51	6205		131	6505	211	7005	
	59	6245		139	6645	219	7045	
	67	6285		147	6685	227	7085	
	75	6325		155	6725			

Channel List								
802.11ax-HE80								
U-NII Band	Channel Number	Freq. (MHz)	U-NII Band	Channel Number	Freq. (MHz)	U-NII Band	Channel Number	Freq. (MHz)
5	7	5985	5	87	6385	7	167	6785
	23	6065	6	103	6465	8	183	6865
	39	6145		119	6545		199	6945
	55	6225	7	135	6625		215	7025
	71	6305		151	6705			

Channel List					
802.11ax-HE160					
U-NII Band	Channel Number	Frequency (MHz)	U-NII Band	Channel Number	Frequency (MHz)
5	15	6025	7	143	6665
	47	6185	8	175	6825
	79	6345		207	6985
6	111	6505			

Note: Test modes are presented at section 3.7.

3.7. Description of Key Components

3.7.1. For the All Component Lists

Item	Supplier	Model / Type	Character
System	Microsoft	Win 10	---
		Win 10 Pro	
		Win11 Home	
Main Board	LG	ROYAL MAIN B/D	GM Manufacturer: #1 Hannstar Board Tech (Jiang Yin) Corp.,Ltd. #2 Elec&Eltek Company (MCO) Limited.
	LG	ROYAL NVIDIA MAIN B/D	PM Manufacturer: #1 Hannstar Board Tech (Jiang Yin) Corp.,Ltd. #2 Elec&Eltek Company (MCO) Limited.
	LG	MTL MAIN B/D*	Manufacturer: #1 Hannstar Board Tech (Jiang Yin) Corp.,Ltd. #2 Elec&Eltek Company (MCO) Limited.
WLAN SUB Board	LG	16Z90R SUB B/D	Manufacturer: #1 HannstarBoardTech(Jiang Yin)Corp.,Ltd. #2 JiangSuHuaShen Electronic co.,ltd (HXF) #3 Elec&Eltek Company (MCO) Limited.
CPU (Socket: BGA1744)	Intel	i7-1360P	2.2GHz
	Intel	i5-1340P	1.9GHz
	Intel	i7-1370P	1.9GHz
	Intel	i5-1350P	1.9GHz
CPU (Socket: BGA2049)	Intel	Ultra 7 155H*	3.8GHz
	Intel	Ultra 5 125H*	3.6GHz
16" LCD Panel	LG Display	LP160WQ1	Resolution: 2560 x 1600, 60Hz WQXGA IPS With Touch Without Touch
	LG Display	LP160WQ2	Resolution: 2560 x 1600, 144Hz WQXGA IPS
Storage (SSD)	SK hynix	---	256GB
		---	512GB
		---	1TB
		---	2TB
	Samsung	---	256GB
		---	512GB
		---	1TB
		---	2TB
Memory (RAM)	Samsung	---	16GB LPDDR5x(On Board)
		---	8GB LPDDR5x(On Board)
		---	32GB LPDDR5x(On Board)
	SK Hynix	---	16GB LPDDR5x(On Board)
		---	8GB LPDDR5x(On Board)
		---	32GB LPDDR5x(On Board)
Battery Pack	LG	LBV122CM	90Wh with PM M/B, DC 7.76V,90Wh
	LG	LBV7227E	80Wh with GM M/B, DC 7.74V,80Wh
	LG	LB3122MM*	77Wh with MTL M/B DC 15.52V, 77Wh

Item	Supplier	Model / Type	Character
WLAN Combo Card	Intel	AX211D2W	WLAN and BT, 2x2 PCIe M.2 1216 SD adapter card FCC ID: PD9AX211D2 IC: 1000M-AX211D2
WLAN Combo Antenna	LG (INPAQ)	WA-P-LELE-04-009	PCB, Mono-pole Type Main: Black, Aux: Gray
	LG (INPAQ)	WA-P-LBLB-04-110	PCB, Mono-pole Type Main: Black, Aux: Gray
	LG (Luxshare)	L1LRF008-CS-H	PCB, Mono-pole Type Main: Black, Aux: Gray
Keyboard	TIC	KT0120B8	---
	LITE-ON	SN8B01	---
Touch Pad	LITE-ON	SP8001(SG-A0630-00A)	---
	ELAN	SD081A-36H0	---
Web Camera	Chicony	CKFLF26	---
	Luxvisions	1BF225N3	---
LAN Gender (Type C to LAN)	SUZHOU MEC ELECTRONICS	80-5946-111	(White) 10/100 Megabit Ethernet
		80-5946-101	(Black) 10/100 Megabit Ethernet
	ARIN TECH CO. LTD	GD-08MF-36-WH-LP10	(White) 10/100 Megabit Ethernet
		GD-08MF-36-BK-LP11	(Black) 10/100 Megabit Ethernet
	HUIZHOU DEHONG TECHNOLOGY CO.,LTD.	370-50713	(White) 10/100 Megabit Ethernet
		370-50714	(Black) 10/100 Megabit Ethernet
Type C to LAN: Shielded, Undetached, 0.12m			
AC Adapter	LG (PI ELECTRONICS)	LP65WFC20P-NJ W	I/P: AC 100-240V, 1.6A, 50-60Hz O/P:DC 5V,3A(15W) or DC 9V, 3A(27W)or DC 15V,3A (45W) or DC 20V,3.25A (65W) (US Type, Wall-mount)
	LG (PI ELECTRONICS)	LP65WFC20P-NJ B	I/P: AC 100-240V, 1.6A, 50-60Hz O/P:DC 5V,3A(15W) or DC 9V, 3A(27W)or DC 15V,3A (45W) or DC 20V,3.25A (65W) (US Type, Wall-mount)
	#1 Type C Cable, Shielded, Undetached, 2.0m #2 Type C Cable, Shielded, Undetached, 2.0m (3A)*		
Note: “*” Standing for adding new configuration.			

Remark: For more detailed features description, please refer to the manufacturer’s specifications or the user manual.

3.7.2. The EUT collocates with following worst components, which are used to establish a basic configuration of system during test:

SKU (Mode)		1	2	3	
Main Board	MTL MAIN B/D	V	V	V	
SUB Board	LG, 16Z90R SUB B/D	V	V	V	
CPU	Intel, Ultra 7 155H	V			
	Intel, Ultra 5 125H		V	V	
16" LCD Panel	LG Display, LP160WQ1 with Touch			V	
	LG Display, LP160WQ1 without Touch	V	V		
Storage (SSD)	SK hynix, 2TB	V	V	V	
	Samsung, 256GB	V	V	V	
Memory (RAM)	Samsung, 32GB	V	V	V	
Battery Pack	LG, 77Wh	V	V	V	
Keyboard	TIC, KT0120B8	V	V	V	
Touch Pad	LITE-ON, SP8001(SG-A0630-00A)	V	V	V	
Web Camera	Chicony, CKFLF26	V	V	V	
WLAN Combo Card	Intel, AX211D2W	V	V	V	
WLAN Combo Antenna	LG (INPAQ), WA-P-LELE-04-009	V			
	LG (Luxshare), L1LRF008-CS-H		V		
	LG (INPAQ), WA-P-LBLB-04-110			V	
Type C #1	AC Adapter	LG (PI ELECTRONICS), LP65WFC20P-NJ W	V	V	V
Type C #2	Link to LAN Gender	MEC (White)	V	V	V

3.8. Test Configuration

Mode	TX _{on} (ms)	1/ TX _{on} (kHz)	TX _{on+off} (ms)	Duty Cycle (x)	Duty Cycle Factor [10log(1/x)] (dB)
802.11ax-HE20	2.600	0.385	2.650	0.981	N/A
802.11ax-HE40	2.600	0.385	2.640	0.985	N/A
802.11ax-HE80	2.590	0.386	2.640	0.981	N/A
802.11ax-HE160	2.420	0.413	2.470	0.980	N/A
26T	0.755	1.325	0.800	0.944	0.250
52T	1.455	0.687	1.500	0.970	0.132
106T	3.030	0.330	3.080	0.984	N/A
242T	1.410	0.709	1.460	0.966	0.150
484T	2.780	0.360	2.830	0.982	N/A
996T	1.330	0.752	1.380	0.964	0.159

Note: When duty cycle is less than 98% (0.98) that duty cycle factor $10\log(1/x)$ is needed to add in conducted test items measured in average detector.

Mode	TX _{on} (ms)	T _{on} +T _{off} (ms)
802.11ax-HE20		
802.11ax-HE40		
802.11ax-HE80		
802.11ax-HE160		

Mode	TX _{on} (ms)	T _{on} +T _{off} (ms)
26T		
52T		
106T		
242T		

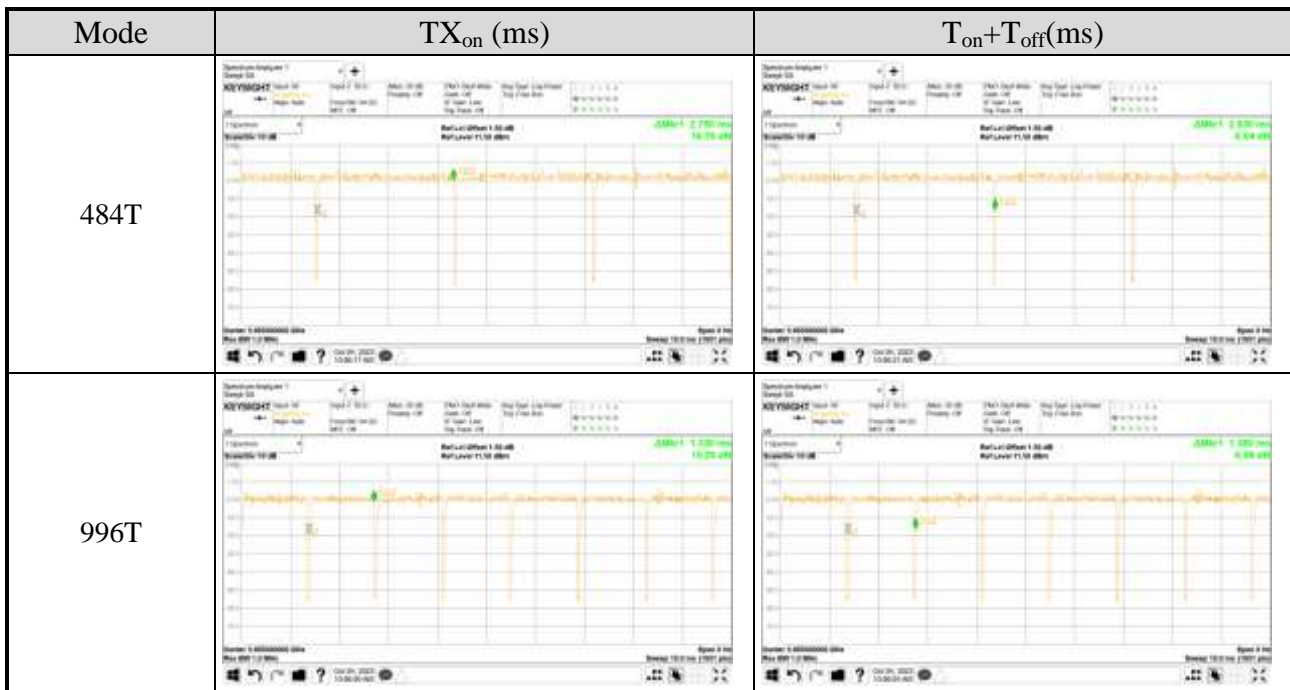

AC Conduction	
SKU #1	Normal operation
SKU #2	Normal operation
SKU #3	Normal operation

Item		Mode	Data Rate	Test Channel
Radiated Test Case	SKU #1	Radiated Spurious Emission (30MHz~1GHz)	802.11ax-HE160	79
	SKU #2		802.11ax-HE160	79
	SKU #3		802.11ax-HE160	79

● OFDM Modulation

Item		Mode	Data Rate	Test Channel	
Radiated Test Case	SKU #1	Radiated Spurious Emission (Above 1GHz)	802.11ax-HE160	HE0	79
	SKU #2		802.11ax-HE40	HE0	227
	SKU #3		802.11ax-HE80	HE0	87

Item		Mode	Data Rate	Test Channel
Conducted Test Case	SKU #1 SKU #2	802.11ax-HE20	HE0	2/45/93/97/105/113/117/149/181/185/209/233
		802.11ax-HE40	HE0	3/43/91/99/107/115/147/179/187/211/227
		802.11ax-HE80	HE0	7/39/87/103/119/135/151/167/183/199/215
		802.11ax-HE160	HE0	15/47/79/111/143/175/207
	SKU #3	802.11ax-HE20	HE0	2/45/93/97/105/113/117/149/181/185/209/233
		802.11ax-HE40	HE0	3/43/91/99/107/115/147/179/187/211/227
		802.11ax-HE80	HE0	7/39/87/103/119/135/151/167/183/199/215
		802.11ax-HE160	HE0	15/47/79/111/143/175/207

● OFDMA Modulation

Item		Tones	RU Index	Mode	Data Rate	Test Channel	
Radiated Test Case	SKU #1	Band Edge ^{Note 5}	26T	8	802.11ax-HE20	HE0	233
	SKU #2		242T	61	802.11ax-HE20	HE0	233
	SKU #3		26T	8	802.11ax-HE20	HE0	233

Item		Tones	RU Index	Mode	Data Rate	Test Channel	
Conducted Test Case	SKU #1 SKU #2	Maximum Conducted Output power (SPOT Check)	26T	0/4/8	802.11ax-HE20	HE0	2/45/93/97/ 105/113/117/ 149/181/185/ 209/233
			52T	37/39/40			
			106T	53/54			
			242T	61			
			26T	0/8/17	802.11ax-HE40	HE0	3/43/91/99/10 7/115/147/179 /187/211/227
			52T	37/40/44			
			106T	53/54/56			
			242T	61/62			
			484T	65	802.11ax-HE80	HE0	7/39/87/103/1 19/135/151/16 7/183/199/215
			26T	0/18/36			
			52T	37/44/52			
			106T	53/56/60			
			242T	61/62/64	802.11ax-HE160	HE0	15/47/79/111/ 143/175/207
			484T	65/66			
			996T	67			
			26T	0/18/36 S0/S18/S36			
			52T	37/44/52 S37/S44/S52			
			106T	53/56/60 S53/S56/S60			
			242T	61/62/64 S61/S62/S64			
			484T	65/66 S65/S66			
			996T	65/S67			

Item			Tones	RU Index	Mode	Data Rate	Test Channel
Conducted Test Case	SKU #3	Maximum Conducted Output power (SPOT Check)	26T	0/4/8	802.11ax-HE20	HE0	2/45/93/97/ 105/113/117/ 149/181/185/ 209/233
			52T	37/39/40			
			106T	53/54			
			242T	61			
			26T	0/8/17	802.11ax-HE40	HE0	3/43/91/99/10 7/115/147/179 /187/211/227
			52T	37/40/44			
			106T	53/54/56			
			242T	61/62			
			484T	65	802.11ax-HE80	HE0	7/39/87/103/1 19/135/151/16 7/183/199/215
			26T	0/18/36			
			52T	37/44/52			
			106T	53/56/60			
			242T	61/62/64			
			484T	65/66	802.11ax-HE160	HE0	15/47/79/111/ 143/175/207
			996T	67			
			26T	0/18/36 S0/S18/S36			
			52T	37/44/52 S37/S44/S52			
			106T	53/56/60 S53/S56/S60			
			242T	61/62/64 S61/S62/S64			
			484T	65/66 S65/S66			
			996T	65/S67			

- Note 1: Mobile Device Portable Device
 and 3 axis were assessed. The worst scenario for Radiated Spurious Emission as follow:
 Lie Side Stand
- Note 2: Low, mid, and high channels were measured, only the worst channel of each modulation was presented in this report.
- Note 3: The data rates were selected based on preliminary testing that identified rate as the worst case for output power.

3.9. Output Power Setting

For SKU (Mode) 1, 2

Mode	U-NII Band	Centre Frequency (MHz)	Power Setting		Mode	U-NII Band	Centre Frequency (MHz)	Power Setting	
			AUX	Main				AUX	Main
802.11ax-HE20	5	5955	1.50	1.50	802.11ax-HE20	7	6535	0.75	0.75
		6175	1.50	1.50			6695	0.75	0.75
		6415	1.50	1.50			6855	0.75	0.75
	6	6435	1.50	1.50		8	6875	0.75	0.75
		6475	1.50	1.50			6995	0.75	0.75
		6515	1.50	1.50			7115	-3.00	-3.00

Mode	U-NII Band	Centre Frequency (MHz)	Power Setting		Mode	U-NII Band	Centre Frequency (MHz)	Power Setting	
			AUX	Main				AUX	Main
802.11ax-HE40	5	5965	4.75	4.75	802.11ax-HE0	7	6525	4.75	4.75
		6165	4.75	4.75			6685	4.00	4.00
		6405	4.75	4.75			6845	4.00	4.00
	6	6445	4.75	4.75		8	6885	4.00	4.00
		6485	4.75	4.75			7005	4.00	4.00
							7085	4.00	4.00

Mode	U-NII Band	Centre Frequency (MHz)	Power Setting		Mode	U-NII Band	Centre Frequency (MHz)	Power Setting	
			AUX	Main				AUX	Main
802.11ax-HE80	5	5985	7.25	7.25	802.11ax-HE80	7	6625	6.50	6.50
		6145	7.25	7.25			6705	6.50	6.50
		6385	7.25	7.25			6785	6.50	6.50
	6	6465	7.25	7.25		8	6865	6.50	6.50
		6545	7.25	7.25			6945	6.50	6.50
							7025	6.50	6.50

Mode	U-NII Band	Centre Frequency (MHz)	Power Setting		Mode	U-NII Band	Centre Frequency (MHz)	Power Setting	
			AUX	Main				AUX	Main
802.11ax-HE160	5	6025	10.00	10.00	802.11ax-HE160	7	6665	9.25	9.25
		6185	10.00	10.00			6825	9.25	9.25
		6345	10.00	10.00		8	6985	9.25	9.25
	6505	10.00	10.00						

For SKU (Mode) 3

Mode	U-NII Band	Centre Frequency (MHz)	Power Setting		Mode	U-NII Band	Centre Frequency (MHz)	Power Setting	
			AUX	Main				AUX	Main
802.11ax-HE20	5	5955	1.000	1.000	802.11ax-HE20	7	6535	0.750	0.750
		6175	1.000	1.000			6695	0.750	0.750
		6415	1.000	1.000			6855	0.750	0.750
	6	6435	1.500	1.500		8	6875	0.750	0.750
		6475	1.500	1.500			6995	0.750	0.750
		6515	1.500	1.500			7115	-3.000	-3.000

Mode	U-NII Band	Centre Frequency (MHz)	Power Setting		Mode	U-NII Band	Centre Frequency (MHz)	Power Setting	
			AUX	Main				AUX	Main
802.11ax-HE40	5	5965	4.250	4.250	802.11ax-HE0	7	6525	4.750	4.750
		6165	4.250	4.250			6685	4.000	4.000
		6405	4.250	4.250			6845	4.000	4.000
	6	6445	4.750	4.750		8	6885	4.000	4.000
		6485	4.750	4.750			7005	4.000	4.000
							7085	4.000	4.000

Mode	U-NII Band	Centre Frequency (MHz)	Power Setting		Mode	U-NII Band	Centre Frequency (MHz)	Power Setting	
			AUX	Main				AUX	Main
802.11ax-HE80	5	5985	6.375	6.375	802.11ax-HE80	7	6625	6.500	6.500
		6145	6.750	6.750			6705	6.500	6.500
		6385	6.750	6.750			6785	6.500	6.500
	6	6465	7.250	7.250		8	6865	6.500	6.500
		6545	7.250	7.250			6945	6.500	6.500
							7025	6.500	6.500

Mode	U-NII Band	Centre Frequency (MHz)	Power Setting		Mode	U-NII Band	Centre Frequency (MHz)	Power Setting	
			AUX	Main				AUX	Main
802.11ax-HE160	5	6025	9.250	9.250	802.11ax-HE160	7	6665	9.250	9.250
		6185	9.375	9.375			6825	9.250	9.250
		6345	9.500	9.500		6985	9.250	9.250	
	6	6505	10.000	10.000					

3.10. Tested Supporting System List

3.10.1. Support Peripheral Unit

No.	Product	Brand	Model No.	Serial No.	Approval
1.	LCD Monitor	DELL	U2718Qb	CN-0M5R5F-QD C00-99P-04CL	N/A
2.	USB Mouse	Lenovo	SM-8823	8SSM50L24506A VLC99H049R	N/A
3.	Earphone	APPLE	N/A	N/A	N/A
4.	SD Card	ADATA	MicroSDHC Card	N/A	N/A
Partner System					
5	AP Server	ASUS	RT-AX88U	N/A	FCC ID: MSQ-RTAXHP00 IC: 3568A-RTAXHP00

3.10.2. Cable Lists

No.	Cable Description Of The Above Support Units
1.	HDMI Cable: Shielded, Detachable, 1.8 AC Power Cord: Unshielded, Detachable, 1.8m
2.	USB Cable: Unshielded, Undetachable, 1.8
3.	Earphone Cable: Unshielded, Undetachable, 1.2m
4.	N/A
5.	AC adapter: M/N:WA-30B12, Cable: Unshielded, Detachable, 1.2m LAN cable: Unshielded, Detachable, 3.0m
6.	LAN cable: Unshielded, Detachable, 1.8m

3.11. Setup Configuration

3.11.1. EUT Configuration for Power Line & Radiated Emission

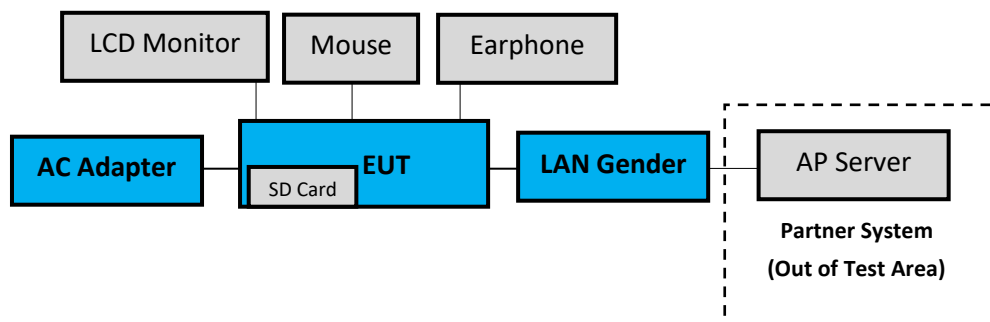

3.11.2. EUT Configuration for RF Conducted Test Items

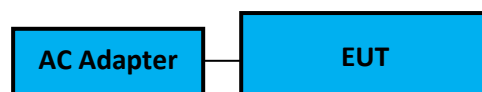

3.12. Operating Condition of EUT

Test program “DRTU” is used for enabling EUT WLAN function under continues transmitting and choosing data rate/ channel.

[ANT AUX port (A Button in DRTU), ANT Main port (B Button in DRTU)].

3.13. Description of Test Facility

Name of Test Firm	Audix Technology Corporation / EMC Department No. 491, Zhongfu Rd., Linkou Dist., New Taipei City 244, Taiwan Tel: +886-2-26092133 Fax: +886-2-26099303 Website : www.audixtech.com Contact e-mail: attemc_report@audixtech.com
Accreditations	The laboratory is accredited by following organizations under ISO/IEC 17025:2017 (1) NVLAP(USA) NVLAP Lab Code 200077-0 (2) TAF(Taiwan) No. 1724
Test Facilities	FCC OET Designation Number under APEC MRA by NCC is : TW1724 ISED CAB Identifier Number under APEC TEL MRA by NCC is TW1724 (1) No.8 Shielded Room (2) No.1 3m Semi Anechoic Chamber

3.14.Measurement Uncertainty

The measurement uncertainty levels have been estimated as specified in ETSI TR 100 028-2001

Test Items/Facilities		Frequency Range	Uncertainty
Conduction Test	<input type="checkbox"/>	No. 7 Shielded Room	9kHz-150kHz ±3.7dB
			150kHz-30MHz ±3.4dB
	<input checked="" type="checkbox"/>	No. 8 Shielded Room	9kHz-150kHz ±3.7dB
			150kHz-30MHz ±3.5dB
Radiation Test	<input checked="" type="checkbox"/>	No.1 3m Semi Anechoic Chamber	30MHz-200MHz, 3m, Horizontal ±3.6dB
			200MHz-1000MHz, 3m, Horizontal ±4.3dB
			30MHz-200MHz, 3m, Vertical ±4.4dB
			200MHz-1000MHz, 3m, Vertical ±4.8dB
			1GHz-6GHz, 3m ±4.8dB
			6GHz-18GHz, 3m ±4.5dB
	<input type="checkbox"/>	No.3 3m Semi Anechoic Chamber	30MHz-200MHz, 3m, Horizontal ±4.0dB
			200MHz-1000MHz, 3m, Horizontal ±4.4dB
			30MHz-200MHz, 3m, Vertical ±4.7dB
			200MHz-1000MHz, 3m, Vertical ±4.5dB
			1GHz-6GHz, 3m ±4.8dB
			6GHz-18GHz, 3m ±4.5dB
	<input type="checkbox"/>	No.4 3m Semi Anechoic Chamber	30MHz-200MHz, 3m, Horizontal ±4.3dB
			200MHz-1000MHz, 3m, Horizontal ±4.2dB
			30MHz-200MHz, 3m, Vertical ±4.8dB
			200MHz-1000MHz, 3m, Vertical ±4.7dB
			1GHz-6GHz, 3m ±4.6dB
			6GHz-18GHz, 3m ±4.4dB
	<input type="checkbox"/>	No.5 3m Semi Anechoic Chamber	30MHz-200MHz, 3m, Horizontal ±4.6dB
			200MHz-1000MHz, 3m, Horizontal ±4.4dB
			30MHz-200MHz, 3m, Vertical ±4.5dB
			200MHz-1000MHz, 3m, Vertical ±4.9dB
			1GHz-6GHz, 3m ±4.9dB
			6GHz-18GHz, 3m ±4.6dB
	Radiated emissions (18GHz-40GHz)	18GHz-40GHz, 3m ±3.4dB	

Remark : Uncertainty = $ku_c(y)$

Test Items	Uncertainty
Maximum Conducted Output Power	± 0.72dB
Contention Based Protocol	± 2%

4. MEASUREMENT EQUIPMENT LIST

4.1. Conducted Emission Measurement

Item	Type	Manufacturer	Model No.	Serial No.	Cal. Date	Cal. Interval
1.	Test Receiver	R&S	ESR3	101774	2023. 01. 11	1 Year
2.	A.M.N.	R&S	ENV432	101567	2023. 06. 02	1 Year
3.	L.I.S.N.	Kyoritsu	KNW-407	8-855-9	2022. 12. 19	1 Year
4.	Pulse Limiter	R&S	ESH3-Z2	100354	2022. 12. 14	1 Year
5.	Digital Thermo-Hygro Meter	iMax	HTC-1	No.8 S/R	2023. 04. 13	1 Year
6.	Coaxial Cable	Yeida	RG/58AU	CE-08	2023. 09. 06	1 Year
7.	Test Software	Audix	e3	V9 18621a	N.C.R.	N.C.R.

4.2. Radiated Emission Measurement

Item	Type	Manufacturer	Model No.	Serial No.	Cal. Date	Cal. Interval
1.	Spectrum Analyzer	Agilent	N9010A-526	MY53400071	2023.08.16	1 Year
2.	Test Receiver	R&S	ESCS30	100338	2023.06.20	1 Year
3.	Amplifier	HP	8447D	2944A06305	2022.12.29	1 Year
4.	Microwave Amplifier	Keysight	83051A	MY56480113	2023.09.11	1 Year
5.	Microwave Amplifier	Agilent	8449B	3008A02678	2023.02.17	1 Year
6.	Loop Antenna	TESEQ	HLA 6121	60478	2023.02.21	1 Year
7.	Bilog Antenna	TESEQ	CBL6112D	33821	2023.06.30	1 Year
8.	Horn Antenna	EMCO	3115	9609-4927	2023.07.21	1 Year
9.	Horn Antenna	COM-POWER	AH-840	101092	2022.12.30	1 Year
10.	Notch Filter	Warison	WFIL-N5925-6425F	WR61CFWC4B1	2023.01.13	1 Year
11.	Notch Filter	Warison	WFIL-N6425-6525F	WR61CFWC6B1	2023.01.13	1 Year
12.	Notch Filter	Warison	WFIL-N6525-6875F	WR61CFWC8B1	2023.01.13	1 Year
13.	Notch Filter	Warison	WFIL-N6875-7125F	WR61CFWC2B1	2023.01.13	1 Year
14.	Coaxial Cable	MIYAZAKI	5D2W	RE-11	2023.01.07	1 Year
15.	Coaxial Cable	HUBER+SUHNER	RG223/U	RE-33	2023.03.02	1 Year
16.	Coaxial Cable	HUBER+SUHNER	SUCOFLEX 106	RE-14	2023.01.07	1 Year
17.	Coaxial Cable	HUBER+SUHNER	SUCOFLEX 102	RE-30	2023.08.21	1 Year
18.	Digital Thermo-Hygro Meter	iMax	HTC-1	No.1 3m A/C	2023.04.13	1 Year
19.	Test Software	Audix	e3	V9 18621a	N.C.R.	N.C.R.

4.3. RF Conducted Measurement

Item	Type	Manufacturer	Model No.	Serial No.	Cal. Date	Cal. Interval
1.	Spectrum Analyzer	Keysight	N9020B-544	MY57120357	2023. 02. 22	1 Year
2.	Power Meter	Anritsu	ML2495A	2127005	2022. 12. 01	1 Year
3.	Power Meter	Anritsu	ML2495A	2127004	2022. 12. 07	1 Year
4.	Power Sensor	Anritsu	MA2411B	1911360	2022. 12. 07	1 Year
5.	Power Sensor	Anritsu	MA2411B	1911356	2022. 12. 01	1 Year
6.	Digital Thermo-Hygro Meter	iMax	HTC-1	RF-03	2023. 04. 13	1 Year

5. CONDUCTED EMISSION

5.1. Block Diagram of Test Setup

5.1.1. Block Diagram of EUT

Indicated as section 3.11

5.1.2. Shielded Room Setup Diagram

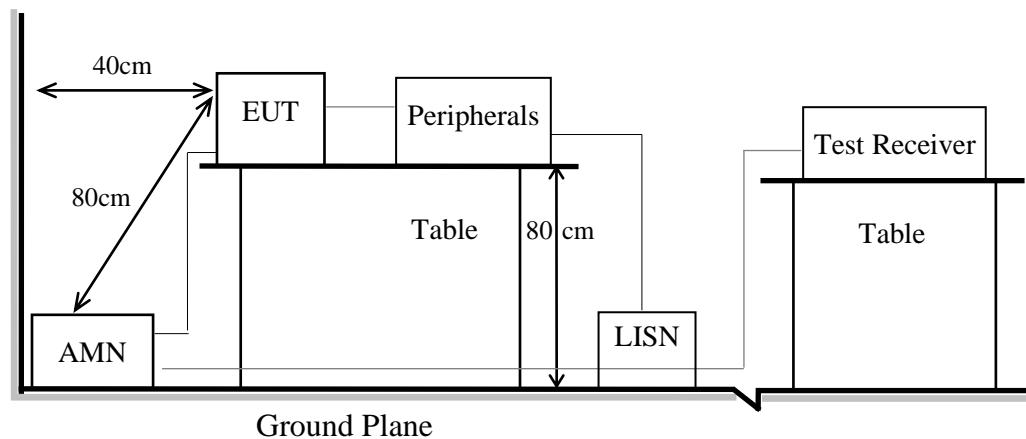

5.2. Conducted Emission Limit

Frequency	Conducted Limit	
	Quasi-Peak Level	Average Level
150kHz ~ 500kHz	66 ~ 56 dB μ V	56 ~ 46 dB μ V
500kHz ~ 5MHz	56 dB μ V	46 dB μ V
5MHz ~ 30MHz	60 dB μ V	50 dB μ V

Remark 1.: If the average limit is met when using a Quasi-Peak detector, the measurement using the average detector is not required.

2.: The lower limit applies to the band edges.

5.3. Test Procedure

- 5.3.1. To set up the EUT as indicated in ANSI C63.10. The EUT was placed on the table which has 80 cm height to the ground and 40 cm distance to the conducting wall.
- 5.3.2. Power supplier of the EUT was connected to the AC mains through an Artificial Mains Network (A.M.N.).
- 5.3.3. The AC power supplies to all peripheral devices must be provided through line impedance stabilization network (L.I.S.N.)
- 5.3.4. Checking frequency range from 150 kHz to 30 MHz and record the emission which does not have 20 dB below limit.

5.4. Test Results

Please refer to Appendix A.

6. RADIATED EMISSION

6.1. Block Diagram of Test Setup

6.1.1. Block Diagram of EUT

Indicated as section 3.11

6.1.2. Setup Diagram for 9kHz-30MHz

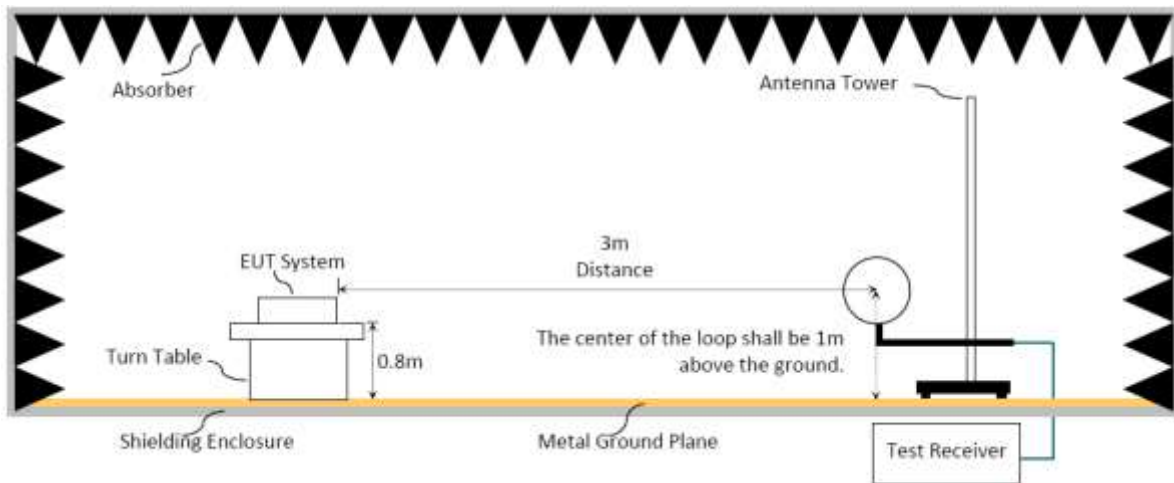

6.1.3. Setup Diagram for 30-1000MHz

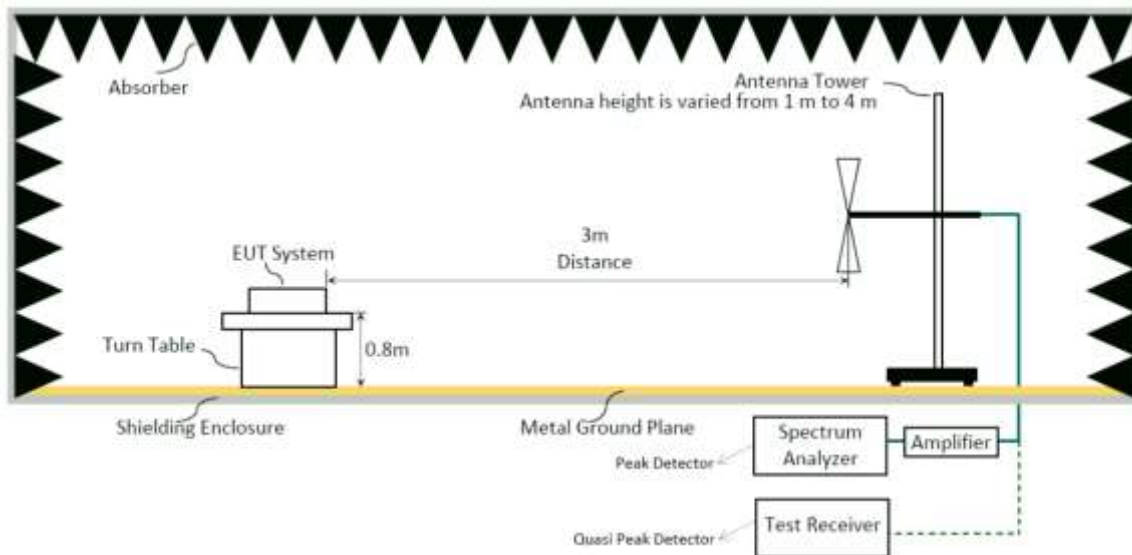

6.1.4. Setup Diagram for above 1GHz

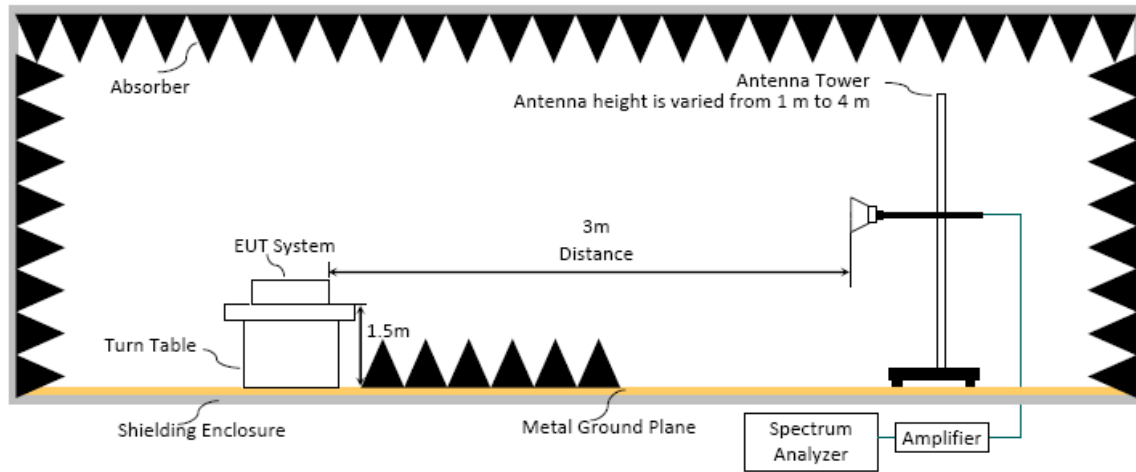

6.2. Radiated Emission Limits

Radiated emissions fall in restricted bands, as defined in FCC Section 15.205/RSS-Gen Section 8.10 table 7 must be in compliance with the radiated emission limits specified in FCC Section 15.209/RSS-Gen Section 8.9 table 6 as below.

6.2.1. General Limit

Frequency (MHz)	Distance(m)	Limits	
		dB μ V/m	μ V/m
0.009 - 0.490	300	67.6-20 log f(kHz)	2400/f kHz
0.490 - 1.705	30	87.6-20 log f(kHz)	24000/f kHz
1.705 - 30	30	29.5	30
30 - 88	3	40.0	100
88- 216	3	43.5	150
216- 960	3	46.0	200
Above 960	3	54.0	500
Above 1000	3	74.0 dB μ V/m (Peak) 54.0 dB μ V/m (Average)	

Remark : (1) dB μ V/m = 20 log (μ V/m)

- (2) The tighter limit applies to the edge between two frequency bands.
- (3) Distance refers to the distance in meters between the measuring instrument antenna and the closed point of any part of the device or system.
- (4) Fundamental and emission fall within operation band are exempted from this section.
- (5) Pursuant to ANSI C63.10: 6.6.4.3, if the maximized peak measured value complies with the average limit, then it is unnecessary to perform an average measurement.

6.2.2. Limit for non-restricted frequency above 1 GHz

Frequency Band (MHz)	E.I.R.P. Limit	Field Strength Limit at 3 m
Out of 5925 to 7125	-27 dBm/MHz	68.2 dB μ V/m

Note: Field Strength at 3 m= E.I.R.P. + 95.2 dB

6.3. Test Procedure

Frequency Range 9kHz~30MHz:

The EUT setup on the turntable which has 0.8 m height to the ground. The turn table rotated 360 degrees and antenna fixed to 1 m to find the maximum emission level. In order to find the maximum emission, all of the interface cables were manipulated according to ANSI C63.10-2013 regulation.

- (1) RBW = 9kHz with peak and average detector.
- (2) Detector: average and peak (9kHz-490kHz)
Q.P. (490kHz-30MHz)

Frequency Range 30MHz ~ 40GHz:

The EUT setup on the turn table which has 80cm (for 30-1000MHz) and 1.5m (for above 1GHz) height to the ground. The turn table rotated 360 degrees and antenna varied from 1 m to 4 m to find the maximum emission level. Both horizontal and vertical polarization are required. In order to find the maximum emission, all of the interface cables were manipulated according to ANSI C63.10-2013 regulation.

6.3.1. Radiated measurement Spectrum Analyzer Setting

6.3.1.1 Frequency below 1GHz:

Spectrum Analyzer is used for pre-testing with following setting:

- (1) RBW = 120kHz
- (2) VBW $\geq 3 \times$ RBW.
- (3) Detector = Peak.
- (4) Sweep time = auto.
- (5) Trace mode = max hold.
- (6) Allow sweeps to continue until the trace stabilizes.

Note 1: When peak-detected value is lower than limit that the measurement using the Q.P. detector is not required, otherwise using Q.P. for final measurement.

Note 2: When the radiated emissions limits are expressed in terms of the average value of the emissions, and pulsed operation is employed, the measurement field strength shall be determined by averaging over one complete pulse train, including blanking intervals, as long as the pulse train does not exceed 0.1 seconds.

6.3.1.2 Frequency above 1GHz to 10th harmonic (up to 40 GHz):

Peak Detector:

- (1) RBW = 1MHz
- (2) VBW $\geq 3 \times$ RBW.
- (3) Detector = Peak.
- (4) Sweep time = auto.
- (5) Trace mode = max hold.
- (6) Allow sweeps to continue until the trace stabilizes.

Note: When peak-detected value is lower than limit that the measurement using the average detector is not required, otherwise using average detector for final measurement.

Average Detector:**■ Option 1:**

(1) RBW = 1MHz

(2) VBW $\geq 1/T$. (Duty Cycle < 98%, when duty cycle presented in section 3.7)

Mode	VBW Setting
26T	1.5kHz
52T	750Hz
242T	750Hz
996T	820Hz

(3) VBW = set VBW \leq RBW / 100, but not less than 10Hz (Duty Cycle \geq 98%, when duty cycle presented in section 3.7)

Mode	VBW Setting
802.11ax-HE20	10Hz
802.11ax-HE40	10Hz
802.11ax-HE80	10Hz
802.11ax-HE160	10Hz
106T	10Hz
484T	10Hz

(4) Detector = Peak.

(5) Sweep time = auto.

(6) Trace mode = max hold.

(7) Allow sweeps to continue until the trace stabilizes.

□ Option 2:

Average Emission Level = Peak Emission Level + D.C.C.F.

6.3.2. Radiated band edge measurement Spectrum Analyzer Setting

For without 99% OBW edge within 2 MHz of the authorized band edge:

The spectrum analyzer setting, please refer to section 6.3.1.2

For with 99% OBW edge within 2 MHz of the authorized band edge:

Per KDB 789033 Section G.3.d and ANSI C63.10 -2013 6.10.4, SA setting as below:

a. Fundamental field strength of SA setting:

The spectrum analyzer setting, please refer to section 6.3.1.2

b. Delta of SA setting:

- (1) RBW = 1% SPAN but no less than 30 KHz
(In this case, RBW = 500 KHz)
- (2) VBW $\geq 3 \times$ RBW.
- (3) Detector = Peak.
- (4) Sweep time = auto.
- (5) Trace mode = max hold.
- (6) Allow sweeps to continue until the trace stabilizes.

Correction Factor (Via delta, dB) = Fundamental Emission Level (dB μ V/m) @ RBW 500KHz - Band Edge Emission Level (dB μ V/m) @ RBW 500kHz

Band Edge Emission Level (dB μ V/m) =
Fundamental Emission Level (dB μ V/m) @ RBW 1MHz - Marker Delta (dB)

6.4. Measurement Result Explanation

- Peak Emission Level (dB μ V/m) = Antenna Factor (dB/m) + Cable Loss (dB) + Meter Reading (dB μ V) (including Preamp factor if test used)
- Average Emission Level (dB μ V/m) = Antenna Factor (dB/m) + Cable Loss (dB) + Meter Reading (dB μ V) (including Preamp factor if test used)
- Average Emission Level (dB μ V/m) = Peak Emission Level (dB μ V/m) + DCCF (dB)
Duty Cycle Correction Factor (DCCF) = $20 \log(TX_{on}/TX_{on+off})$ presented in section 3.7.
- ERP = Peak Emission Level (dB μ V/m) - 95.2dB - 2.14dB
- Band Edge Emission Level (dB μ V/m) = Fundamental Emission Level (dB μ V/m) - Marker-Delta (dB)

6.5. Test Results

Please refer to Appendix A.

7. MAXIMUM CONDUCTED OUTPUT POWER

7.1. Block Diagram of Test Setup

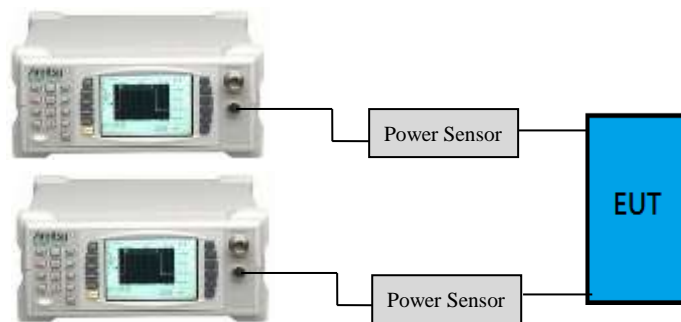

- For 802.11ac-VHT80/160, 802.11ax-HE160 modes only

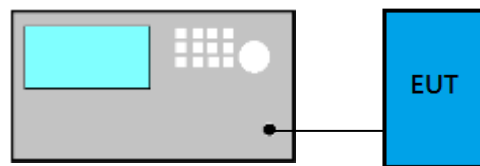

7.2. Specification Limits

For client devices operating under the control of an indoor access point in the 5.925-7.125 GHz bands, the maximum e.i.r.p. over the frequency band of operation must not exceed 24 dBm.

7.3. Test Procedure

Following measurement procedure is reference to KDB 789033 D02 General UNII Test Procedures New Rules v02r01:

■ **Method AVGPM (Measurement using an RF average power meter):**

EUT is connected to power sensor and record the maximum average output power and duty cycle factor is added when duty cycle presented in section 3.7 is < 98%.

■ **Method AVGSA-2 (Spectrum channel power) for 802.11ac-VHT80/160, 802.11ax-HE80/160 modes only**

- (1) Set span to at least 1.5 times the OBW
- (2) Set RBW = 1 MHz
- (3) Set the video bandwidth (VBW) \geq 3 MHz.
- (4) Detector = RMS.
- (5) Trace mode = trace average at least 100 traces
- (6) Sweep = auto couple.
- (7) Compute power by integrating the spectrum across the OBW of the signal using the instrument's band power measurement function with band limits set equal to the OBW band edges.
- (8) Duty cycle factor is added when duty cycle presented in section 3.7 is < 98%.

7.4. Test Results

Please refer to Appendix A



8. DEVIATION TO TEST SPECIFICATIONS

【NONE】



APPENDIX A

TEST DATA AND PLOTS

(Model: 16Z90S)



*Audix Technology Corp.
No. 491, Zhongfu Rd., Linkou Dist.,
New Taipei City 244, Taiwan*

*Tel: +886 2 26099301
Fax: +886 2 26099303*

APPENDIX B

TEST PHOTOGRAPHS

(Model: 16Z90S)