

**FCC 15.247 & RSS-247  
(Permissive Change)  
2.4GHz Test Report**

**for**

**LG Electronics Inc.**

**222, LG-ro, Jinwi-myeon Pyeongtaek-Si, Gyeonggi-Do,  
17709 Republic of Korea**

**Product Name : Notebook Computer**  
**Model Name : (1)16Z90R (2)16ZD90R  
(3)16Z90S (4)16ZD90S**  
**Brand : LG**  
**FCC ID : BEJNT-16Z90R**  
**IC : 2703H-16Z90R**

**Prepared by: : AUDIX Technology Corporation,  
EMC Department**



The test report is based on a single evaluation of one sample of the above-mentioned products. It does not imply an assessment of the whole production and does not permit the use of the test lab logo.

## TABLE OF CONTENTS

Description	Page
TEST REPORT .....	4
<b>1. REVISION RECORD OF TEST REPORT .....</b>	<b>4</b>
<b>2. SUMMARY OF TEST RESULTS .....</b>	<b>5</b>
<b>3. GENERAL INFORMATION .....</b>	<b>6</b>
3.1. Description of Application .....	6
3.2. Description of EUT .....	8
3.3. Reference Test Guidance.....	9
3.4. Information for Permissive Change.....	10
3.5. Antenna Information .....	11
3.6. EUT Specifications Assessed in Current Report.....	13
3.7. Descriptions of Key Components.....	15
3.8. Test Configuration.....	18
3.9. Output Power Setting .....	25
3.10. Tested Supporting System List.....	28
3.11. Setup Configuration.....	28
3.12. Operating Condition of EUT .....	29
3.13. Description of Test Facility .....	29
3.14. Measurement Uncertainty .....	30
<b>4. MEASUREMENT EQUIPMENTLIST.....</b>	<b>31</b>
4.1. Conducted Emission Measurement .....	31
4.2. Radiated Emission Measurement .....	32
4.3. RF Conducted Measurement .....	32
<b>5. CONDUCTED EMISSION.....</b>	<b>33</b>
5.1. Block Diagram of Test Setup .....	33
5.2. Conducted Emission Limit .....	33
5.3. Test Procedure .....	33
5.4. Test Results .....	33
<b>6. RADIATED EMISSION .....</b>	<b>34</b>
6.1. Block Diagram of Test Setup .....	34
6.2. Radiated Emission Limits.....	35
6.3. Test Procedure .....	36
6.4. Measurement Result Explanation.....	37
6.5. Test Results .....	37
<b>7. MAXIMUM PEAK OUTPUT POWER.....</b>	<b>38</b>
7.1. Block Diagram of Test Setup .....	38
7.2. Specification Limits.....	38
7.3. Test Procedure .....	39
7.4. Test Results .....	39
<b>8. DEVIATION TO TEST SPECIFICATIONS .....</b>	<b>40</b>
APPENDIX A TEST DATA AND PLOTS	
APPENDIX B TESTPHOTOGRAPHS	

## TEST REPORT (Permissive Change)

Applicant : LG Electronics Inc.  
Manufacturer : LG Electronics Inc.  
Factory : LG Electronics Nanjing New Technology Co., Ltd.  
EUT Description  
(1) Product : Notebook Computer  
(2) Model : (1)16Z90R (2)16ZD90R (3)16Z90S (4)16ZD90S  
(3) Brand : LG  
(4) Power Supply: DC 20V, 3.25A

### Applicable Standards:

Title 47 CFR FCC Part 15 Subpart C  
RSS-Gen (Issue 5), Amendment 2, February 2021  
RSS-247 (Issue 2), February 2017

**Audix Technology Corp.** tested the equipment mentioned in accordance with the requirements set forth in the above standards. Test results indicate that the equipment tested is capable of demonstrating compliance with the requirements as documented within this report.

**Audix Technology Corp.** does not assume responsibility for any conclusions and generalizations drawn from the test results with regard to other specimens and samples.

Date of Report: 2023. 10. 11

Reviewed by:



(Annie Yu/Administrator)

Approved by:



(Johnny Hsueh/Section Manager)

## 1. REVISION RECORD OF TEST REPORT

Edition No	Issued Data	Revision Summary	Report Number
0	2023. 10. 11	Original Report	EM-F230458

## 2. SUMMARY OF TEST RESULTS

Rule		Description	Results
FCC	IC		
15.207	RSS-Gen §8.8	Conducted Emission	<b>PASS</b>
15.247(d)/ 15.205	RSS-Gen §8.9 RSS-247 §5.5	Radiated Band Edge and Radiated Spurious Emission	<b>PASS</b>
15.247(a)(2)	RSS-247 §5.2(1)	DTS/Occupied Bandwidth	N/A <sup>Note3</sup>
15.247(b)(3)	RSS-247 §5.4(4)	Maximum Peak Output Power	<b>PASS</b>
15.247(d)	RSS-247 §5.5	Conducted Band Edges and Conducted Spurious Emission	N/A <sup>Note3</sup>
15.247 (e)	RSS-247 §5.2(2)	Peak Power Spectral Density	N/A <sup>Note3</sup>
15.203	---	Antenna Requirement	<b>Compliance</b>

Note: 1. Decision rule according to the limit of the test standard chapter, the test value is lower than the limit specified in the test chapter, and it is judged as Pass.  
2. The uncertainties value is not used in determining the result.  
3. Due to the difference mentioned by cover letter don't influence on RF characteristics, so it is unnecessary to re-test.

### 3. GENERAL INFORMATION

#### 3.1. Description of Application

Applicant	LG Electronics Inc. 222, LG-ro, Jinwi-myeon Pyeongtaek-Si, Gyeonggi-Do, 17709 Republic of Korea
Manufacturer	LG Electronics Inc. 222, LG-ro, Jinwi-myeon Pyeongtaek-Si, Gyeonggi-Do, 17709 Republic of Korea
Factory	LG Electronics Nanjing New Technology Co., Ltd. No.346, Yaoxin Road, Economic & Technical Development Zone, Nanjing, China.
Product	Notebook Computer
Model	(1)16Z90R (2)16ZD90R (3)16Z90S (4)16ZD90S The difference between all models is different in the sales customers, color difference and component.
Configuration (HVIN)	16Z90R-K, 16Z90R-N, 16Z90R-A, 16Z90R-R, 16Z90R-Q, 16Z90R-H, 16Z90R-T, 16Z90S-G, 16Z90S-V, 16Z90S-M, 16Z90S-C and 16Z90S-H
Brand	LG

The model 16Z90R series has following different configuration and components, and the details are as follows:

Difference		Main Board	GPU	Battery	CPU	TPM (Trusted Platform Module)	Panel Touch Function	Antenna		
Original	16Z90R-K	ROYAL MAIN B/D	Intel Iris Xe Graphics	LBV7227E (80 Wh)	Intel, i7-1360P Intel, i5-1340P	Not Support	Without	#1 WA-P-LELE-04-009 #2 L1LRF008-CS-H		
	16Z90R-N					Support				
	16Z90R-A	ROYAL NVIDIA MAIN B/D	NVIDIA GeForce RTX 3050	LBV7227E (90 Wh)		Not Support				
	16Z90R-R					Support				
	16Z90R-Q	ROYAL MAIN B/D	Intel Iris Xe Graphics	LBV7227E (80 Wh)	Intel, i7-1370P Intel, i5-1350P	Support				
	16Z90R-H	ROYAL MAIN B/D	Intel Iris Xe Graphics	LBV7227E (80 Wh)	Intel, i7-1360P Intel, i5-1340P	Not Support			With	#3 WA-P-LBLB-04-110
	16Z90R-T					Support				
This Time	16Z90S-G	MTL MAIN B/D	Intel Arc Graphics	LB3122MM (77 Wh)	Intel, Ultra 7 155H Intel, Ultra 5 125H	Not Support	Without	#1 WA-P-LELE-04-009 #2 L1LRF008-CS-H		
	16Z90S-V		Intel Arc Graphics			Support				
	16Z90S-M		Intel Arc Graphics			Not Support				
	16Z90S-C		Intel Arc Graphics			Not Support				
	16Z90S-H		Intel Arc Graphics			Not Support			With	#3 WA-P-LBLB-04-110

### 3.2. Description of EUT

Test Model	16Z90S		
Serial Number	N/A		
Power Rating	DC 20V, 3.25A		
Software Version	XY (X, Y can be 0 to 9 for different SW version not influence RF parameter)		
RF Features	WLAN:802.11 a/b/g/n/ac/ax Bluetooth: BT and BLE (BT 5.1)		
Transmit Type	<b>2.4 GHz</b>		
	802.11b		1T1R
	802.11g		1T1R
	802.11n-HT20		2T2R
	802.11n-HT40		2T2R
	802.11ax-HE20		2T2R
	802.11ax-HE40		2T2R
	BT/BLE		1T1R
	<b>U-NII Bands</b>		
	802.11a		1T1R
	802.11n-HT20/802.11ac-VHT20/802.11ax-HE20		2T2R
	802.11n-HT40/802.11ac-VHT40/802.11ax-HE40		2T2R
	802.11ac-VHT80/802.11ax-HE80		2T2R
	802.11ac-VHT160/802.11ax-HE160		2T2R
	The MIMO is uncorrelated and supported SDM(Spatial Division Multiplexing) mode only. This radio device doesn't support beamforming and Cyclic Delay Diversity (CDD).		
Sample Status	Trial sample		
Test Sample	<b>Sample No.</b>	<b>Test Item</b>	<b>Firmware</b>
	01	AC Conduction, RSE, Output Power	N/A
	02	AC Conduction, RSE, Output Power	N/A
Date of Receipt	2023. 09. 06		
Date of Test	2023. 09. 28 ~ 10. 06		



Interface Ports of EUT	<ul style="list-style-type: none"><li>• One HDMI Port</li><li>• Two USB Type C Ports</li><li>• One Earphone Port</li><li>• One Micro SD Card Slot</li><li>• Two USB 3.0 Ports</li></ul>
Accessories Supplied	<ul style="list-style-type: none"><li>• AC Adapter</li><li>• USB C Cable*2</li><li>• LAN Gender</li></ul>

Note: Pursuant ISO 17025:2017 section 7.8.2, Audix Technology Corp. does not assume responsibility for all EUT's information including RF features, transmit type, antenna information...etc are provided by customer.

### 3.3. Reference Test Guidance

KDB 662911 D01 Multiple Transmitter Output v02r01  
ANSI C63.10:2013

### 3.4. Information for Permissive Change

- The EUT is an addition version with original FCC ID: BEJNT-16Z90R and IC: 2703H-16Z90R are as following.
  - (a) To add new models 16Z90S and 16ZD90S.
  - (b) To add new Configuration (HVIN) 16Z90S-G, 16Z90S-V, 16Z90S-M, 16Z90S-C and 16Z90S-H.
  - (c) Based on original ROYAL MAIN B/D main board, the difference between ROYAL MAIN B/D main board and MTL MAIN B/D main board is refer to Cover Letter-Permissive Change. The MTL MAIN B/D main board is for new Configuration (HVIN) 16Z90S-G, 16Z90S-V, 16Z90S-M, 16Z90S-C and 16Z90S-H.
  - (d) To add new CPUs for MTL MAIN B/D main board.
  - (e) To add new Battery Pack for MTL MAIN B/D main board.
  - (f) To add new Type C cable (3A).
- The differences between this application and original's ID as clarify in following list.

Configuration (HVIN)		Difference								
		Main Board	GPU	Battery	CPU	TPM (Trusted Platform Module)	Panel Touch Function	Antenna		
Original	16Z90R-K	ROYAL MAIN B/D	Intel Iris Xe Graphics	LBV7227E (80 Wh)	Intel, i7-1360P Intel, i5-1340P	Not Support	Without	#1 WA-P-LELE-04-009 #2 L1LRF008-CS-H		
	16Z90R-N					Support				
	16Z90R-Q	ROYAL MAIN B/D	Intel Iris Xe Graphics	LBV7227E (80 Wh)	Intel, i7-1370P Intel, i5-1350P	Support				
	16Z90R-H	ROYAL MAIN B/D	Intel Iris Xe Graphics	LBV7227E (80 Wh)	Intel, i7-1360P Intel, i5-1340P	Not Support			With	#3 WA-P-LBLB-04-110
	16Z90R-T					Support				
This Time	16Z90S-G	MTL MAIN B/D	Intel Arc Graphics	LB3122MM (77 Wh)	Intel, Ultra 7 155H Intel, Ultra 5 125H	Not Support	Without	#1 WA-P-LELE-04-009 #2 L1LRF008-CS-H		
	16Z90S-V		Intel Arc Graphics			Support				
	16Z90S-M		Intel Arc Graphics			Not Support				
	16Z90S-C		Intel Arc Graphics			Not Support				
	16Z90S-H		Intel Arc Graphics			Not Support	With	#3 WA-P-LBLB-04-110		

- Due to above different item, there have some test item should be re-tested (see section 2), the test data are recorded in this report.

### 3.5. Antenna Information

No.	Antenna Part Number	Manufacture	Antenna Type	Frequency (MHz)	Max Gain(dBi)	
					Main	AUX
1.	WA-P-LELE-04-009	INPAQ	Mono-Pole	2400	2.2	1.9
				2450	2.3	2.4
				2500	3.1	2.3
				5150	4.2	3.6
				5400	4.2	3.7
				5850	4.0	3.5
				5925	4.3	3.5
				6525	4.2	3.5
				7125	4.1	2.3

According to KDB 662911 D01 d) ii), transmit signals are completely uncorrelated, then  
 Directional gain =  $10 \log[(10^{G1/10} + 10^{G2/10} + \dots + 10^{GN/10})/N_{ANT}]$  dBi

Note 1. 2.4G: Directional gain =

2400MHz: Directional gain =  $10 \log[(10^{2.2/10} + 10^{1.9/10})/2] = 2.05$ dBi

2450MHz: Directional gain =  $10 \log[(10^{2.3/10} + 10^{2.4/10})/2] = 2.35$ dBi

Note 2. 5G: Directional gain =

5150MHz: =  $10 \log[(10^{4.2/10} + 10^{3.6/10})/2] = 3.91$ dBi

5250MHz: =  $10 \log[(10^{4.2/10} + 10^{3.6/10})/2] = 3.91$ dBi

5350MHz: =  $10 \log[(10^{4.2/10} + 10^{3.7/10})/2] = 3.96$ dBi

5725MHz: =  $10 \log[(10^{4.0/10} + 10^{3.5/10})/2] = 3.76$ dBi

5825MHz: =  $10 \log[(10^{4.0/10} + 10^{3.5/10})/2] = 3.76$ dBi

Note 3. UNII Band (WLAN 6G):

5925MHz: Directional gain =  $10 \log[(10^{4.3/10} + 10^{3.5/10})/2] = 3.92$ dBi

6525MHz: Directional gain =  $10 \log[(10^{4.2/10} + 10^{3.5/10})/2] = 3.86$ dBi

7125MHz: Directional gain =  $10 \log[(10^{4.1/10} + 10^{2.3/10})/2] = 3.29$ dBi

We chose the antenna gain corresponding to the frequency listed on the table which is closer to center frequency of WLAN.

No.	Antenna Part Number	Manufacture	Antenna Type	Frequency (MHz)	Max Gain(dBi)	
					Main	AUX
2.	L1LRF008-CS-H	LUXSHARE-ICT	Mono-Pole	2400	6.3	0.9
				2450	5.7	1.6
				2500	2.7	3.5
				5150	-1.5	2.3
				5400	3.4	4.5
				5850	3.3	5.8
				5925	2.9	4.7
				6525	3.4	1.3
				7125	-4.9	-1.6

According to KDB 662911 D01 d) ii), transmit signals are completely uncorrelated, then

$$\text{Directional gain} = 10 \log[(10^{G1/10} + 10^{G2/10} + \dots + 10^{GN/10})/N_{ANT}] \text{ dBi}$$

Note 1. 2.4G: Directional gain =

$$2400\text{MHz: Directional gain} = 10 \log[(10^{6.3/10} + 10^{0.9/10})/2] = 4.42\text{dBi}$$

$$2450\text{MHz: Directional gain} = 10 \log[(10^{5.7/10} + 10^{1.6/10})/2] = 4.11\text{dBi}$$

Note 2. 5G: Directional gain =

$$5150\text{MHz:} = 10 \log[(10^{-1.5/10} + 10^{2.3/10})/2] = 0.80\text{dBi}$$

$$5250\text{MHz:} = 10 \log[(10^{-1.5/10} + 10^{2.3/10})/2] = 0.80\text{dBi}$$

$$5350\text{MHz:} = 10 \log[(10^{3.4/10} + 10^{4.5/10})/2] = 3.99\text{dBi}$$

$$5725\text{MHz:} = 10 \log[(10^{3.3/10} + 10^{5.8/10})/2] = 4.70\text{dBi}$$

$$5825\text{MHz:} = 10 \log[(10^{3.3/10} + 10^{5.8/10})/2] = 4.70\text{dBi}$$

Note 3. UNII Band (WLAN 6G):

$$5925\text{MHz: Directional gain} = 10 \log[(10^{2.9/10} + 10^{4.7/10})/2] = 3.92\text{dBi}$$

$$6525\text{MHz: Directional gain} = 10 \log[(10^{3.4/10} + 10^{1.3/10})/2] = 2.48\text{dBi}$$

$$7125\text{MHz: Directional gain} = 10 \log[(10^{-4.9/10} + 10^{-1.6/10})/2] = -2.99\text{dBi}$$

We chose the antenna gain corresponding to the frequency listed on the table which is closer to center frequency of WLAN.

No.	Antenna Part Number	Manufacture	Antenna Type	Frequency (MHz)	Gain(dBi)	
					Main	AUX
3.	WA-P-LBLB-04-1 10	INPAQ	Mono-Pole	2400-2500	3.1	2.9
				5150-5350	-2.1	2.8
				5470-5725	2.5	5.7
				5725-5850	5.2	5.3
				5925-6425	4.8	3.7
				6425-6525	1.0	-1.0
				6525-6875	1.6	2.8
				6875-7125	2.9	-1.4

According to KDB 662911 D01 d) ii), transmit signals are completely uncorrelated, then

$$\text{Directional gain} = 10 \log[(10^{G1/10} + 10^{G2/10} + \dots + 10^{GN/10})/N_{ANT}] \text{ dBi}$$

$$\text{Note : WLAN 2.4GHz: Directional gain} = 10 \log[(10^{2.6/10} + 10^{2.7/10})/2] = 3.0\text{dBi}$$

### 3.6. EUT Specifications Assessed in Current Report

Mode	Fundamental Range (MHz)	Channel Number	Modulation	Data Rate (Mbps)
802.11b	2412-2472	13	DSSS (DBPSK/DQPSK/CCK)	Up to 11
802.11g		13	OFDM (BPSK/QPSK/16QAM/64QAM)	Up to 54
802.11n-HT20				Up to 144.4
802.11n-HT40	2422-2462	9	OFDM (BPSK/QPSK/16QAM/64QAM)	Up to 300
802.11ax-HE20	2412-2472	13	OFDMA (BPSK/ QPSK/ 16QAM/ 64QAM/ 256QAM/1024QAM)	Up to 287
802.11ax-HE40	2422-2462	9		Up to 574
BLE	2402-2480	40	GFSK (1Mbps, 2Mbps, PHY Coded S8, PHY Coded S2)	Up to 2

Channel List			
802.11 b/g/n-HT20/ax-HE20		802.11n-HT40/ax-HE40	
Channel Number	Frequency (MHz)	Channel Number	Frequency (MHz)
1	2412	3	2422
2	2417	4	2427
3	2422	5	2432
4	2427	6	2437
5	2432	7	2442
6	2437	8	2447
7	2442	9	2452
8	2447	10	2457
9	2452	11	2462
10	2457		
11	2462		
12	2467		
13	2472		

Channel List							
BLE							
Channel Number	Frequency (MHz)	Channel Number	Frequency (MHz)	Channel Number	Frequency (MHz)	Channel Number	Frequency (MHz)
37	2402	09	2422	18	2442	28	2462
00	2404	10	2424	19	2444	29	2464
01	2406	38	2426	20	2446	30	2466
02	2408	11	2428	21	2448	31	2468
03	2410	12	2430	22	2450	32	2470
04	2412	13	2432	23	2452	33	2472
05	2414	14	2434	24	2454	34	2474
06	2416	15	2436	25	2456	35	2476
07	2418	16	2438	26	2458	36	2478
08	2420	17	2440	27	2460	39	2480

### 3.7. Descriptions of Key Components

#### 3.7.1. For the All Component Lists

Item	Supplier	Model / Type	Character
System	Microsoft	Win 10	---
		Win 10 Pro	
		Win11 Home	
Main Board	LG	ROYAL MAIN B/D	GM Manufacturer: #1 Hannstar Board Tech (Jiang Yin) Corp.,Ltd. #2 Elec&Eltek Company (MCO) Limited.
	LG	ROYAL NVIDIA MAIN B/D	PM Manufacturer: #1 Hannstar Board Tech (Jiang Yin) Corp.,Ltd. #2 Elec&Eltek Company (MCO) Limited.
	LG	MTL MAIN B/D*	<b>Manufacturer: #1 Hannstar Board Tech (Jiang Yin) Corp.,Ltd. #2 Elec&amp;Eltek Company (MCO) Limited.</b>
WLAN SUB Board	LG	16Z90R SUB B/D	Manufacturer: #1 HannstarBoardTech(Jiang Yin)Corp.,Ltd. #2 JiangSuHuaShen Electronic co.,ltd (HXF) #3 Elec&Eltek Company (MCO) Limited.
CPU (Socket: BGA1744)	Intel	i7-1360P	2.2GHz
	Intel	i5-1340P	1.9GHz
	Intel	i7-1370P	1.9GHz
	Intel	i5-1350P	1.9GHz
CPU (Socket: BGA2049)	Intel	Ultra 7 155H*	3.8GHz
	Intel	Ultra 5 125H*	3.6GHz
16" LCD Panel	LG Display	LP160WQ1	Resolution: 2560 x 1600, 60Hz WQXGA IPS With Touch Without Touch
	LG Display	LP160WQ2	Resolution: 2560 x 1600, 144Hz WQXGA IPS
Storage (SSD)	SK hynix	---	256GB
		---	512GB
		---	1TB
		---	2TB
	Samsung	---	256GB
		---	512GB
		---	1TB
		---	2TB
Memory (RAM)	Samsung	---	16GB LPDDR5x(On Board)
		---	8GB LPDDR5x(On Board)
		---	32GB LPDDR5x(On Board)
	SK Hynix	---	16GB LPDDR5x(On Board)
		---	8GB LPDDR5x(On Board)
		---	32GB LPDDR5x(On Board)
Battery Pack	LG	LBY122CM	90Wh with PM M/B, DC 7.76V,90Wh
	LG	LBV7227E	80Wh with GM M/B, DC 7.74V,80Wh
	LG	LB3122MM*	77Wh with MTL M/B DC 15.52V, 77Wh

Item	Supplier	Model / Type	Character
WLAN Combo Card	Intel	AX211D2W	WLAN and BT, 2x2 PCIe M.2 1216 SD adapter card FCC ID: PD9AX211D2 IC: 1000M-AX211D2
WLAN Combo Antenna	LG (INPAQ)	WA-P-LELE-04-009	PCB, Mono-pole Type Main: Black, Aux: Gray
	LG (INPAQ)	WA-P-LBLB-04-110	PCB, Mono-pole Type Main: Black, Aux: Gray
	LG (Luxshare)	L1LRF008-CS-H	PCB, Mono-pole Type Main: Black, Aux: Gray
Keyboard	TIC	KT0120B8	---
	LITE-ON	SN8B01	---
Touch Pad	LITE-ON	SP8001(SG-A0630-00A)	---
	ELAN	SD081A-36H0	---
Web Camera	Chicony	CKFLF26	---
	Luxvisions	1BF225N3	---
LAN Gender (Type C to LAN)	SUZHOU MEC ELECTRONICS	80-5946-111	(White) 10/100 Megabit Ethernet
		80-5946-101	(Black) 10/100 Megabit Ethernet
	ARIN TECH CO. LTD	GD-08MF-36-WH-LP10	(White) 10/100 Megabit Ethernet
		GD-08MF-36-BK-LP11	(Black) 10/100 Megabit Ethernet
	HUIZHOU DEHONG TECHNOLOGY CO.,LTD.	370-50713	(White) 10/100 Megabit Ethernet
		370-50714	(Black) 10/100 Megabit Ethernet
Type C to LAN: Shielded, Undetached, 0.12m			
AC Adapter	LG (PI ELECTRONICS)	LP65WFC20P-NJ W	I/P: AC 100-240V, 1.6A, 50-60Hz O/P:DC 5V,3A(15W) or DC 9V, 3A(27W)or DC 15V,3A (45W) or DC 20V,3.25A (65W) (US Type, Wall-mount)
	LG (PI ELECTRONICS)	LP65WFC20P-NJ B	I/P: AC 100-240V, 1.6A, 50-60Hz O/P:DC 5V,3A(15W) or DC 9V, 3A(27W)or DC 15V,3A (45W) or DC 20V,3.25A (65W) (US Type, Wall-mount)
	#1 Type C Cable, Shielded, Undetached, 2.0m #2 Type C Cable, Shielded, Undetached, 1.8m (3A)*		
Note: “*” Standing for adding new configuration.			

Remark: For more detailed features description, please refer to the manufacturer’s specifications or the user manual.



3.7.2. The EUT collocates with following worst components, which are used to establish a basic configuration of system during test:

SKU (Mode)		1	2	3	
Main Board	MTL MAIN B/D	V	V	V	
SUB Board	LG, 16Z90R SUB B/D	V	V	V	
CPU	Intel, Ultra 7 155H	V			
	Intel, Ultra 5 125H		V	V	
16" LCD Panel	LG Display, LP160WQ1 with Touch			V	
	LG Display, LP160WQ1 without Touch	V	V		
Storage (SSD)	SK hynix, 2TB	V	V	V	
	Samsung, 256GB	V	V	V	
Memory (RAM)	Samsung, 32GB	V	V	V	
Battery Pack	LG, 77Wh	V	V	V	
Keyboard	TIC, KT0120B8	V	V	V	
Touch Pad	LITE-ON, SP8001(SG-A0630-00A)	V	V	V	
Web Camera	Chicony, CKFLF26	V	V	V	
WLAN Combo Card	Intel, AX211D2W	V	V	V	
WLAN Combo Antenna	LG (INPAQ), WA-P-LELE-04-009	V			
	LG (Luxshare), L1LRF008-CS-H		V		
	LG (INPAQ), WA-P-LBLB-04-110			V	
Type C #1	AC Adapter	LG (PI ELECTRONICS), LP65WFC20P-NJ W	V	V	V
Type C #2	Link to LAN Gender	MEC (White)	V	V	V

### 3.8. Test Configuration

Mode	TX <sub>on</sub> (ms)	TX <sub>on+off</sub> (ms)	Duty Cycle (x)	Duty Cycle Factor [10log(1/x)] (dB)
802.11b	8.360	8.400	0.995	N/A
802.11g	2.100	2.140	0.981	N/A
802.11n-HT20	2.620	2.660	0.985	N/A
802.11n-HT40	2.620	2.660	0.985	N/A
802.11ax-HE20	2.610	2.655	0.983	N/A
802.11ax-HE40	2.595	2.640	0.983	N/A
802.11ax-HE20 (RU Config 26)	0.755	0.810	0.932	0.306
802.11ax-HE20 (RU Config 52)	1.455	1.510	0.964	0.159
802.11ax-HE20 (RU Config 106)	3.030	3.090	0.981	N/A
802.11ax-HE40 (RU Config 242)	1.420	1.470	0.966	0.150

Note: When duty cycle is less than 98% (0.98) that duty cycle factor 10log(1/x) is needed to add in conducted test items measured in average detector.

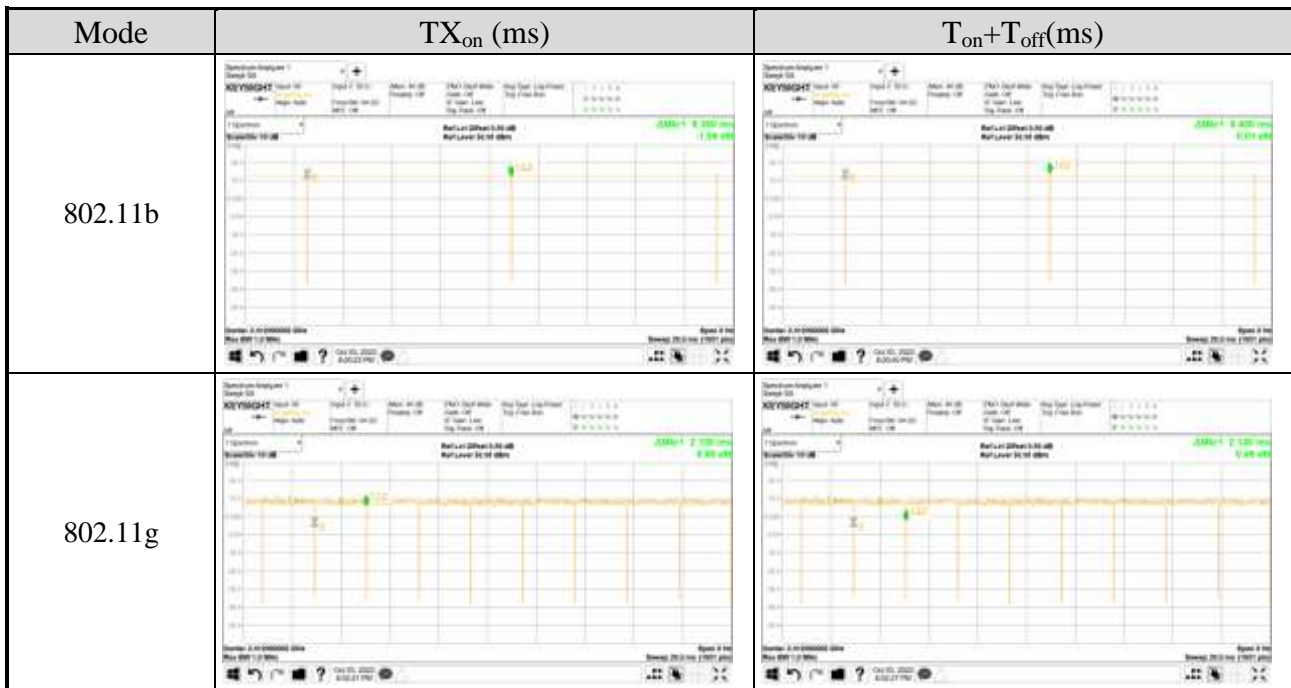

Mode	TX <sub>on</sub> (ms)	T <sub>on</sub> +T <sub>off</sub> (ms)
802.11n-HT20		
802.11n-HT40		
802.11ax-HE20		
802.11ax-HE40		

Mode	TX <sub>on</sub> (ms)	T <sub>on</sub> +T <sub>off</sub> (ms)
802.11ax-HE20 (RU Config 26)		
802.11ax-HE20 (RU Config 52)		
802.11ax-HE20 (RU Config 106)		
802.11ax-HE40 (RU Config 242)		

Mode	TX <sub>on</sub> (ms)	TX <sub>on+off</sub> (ms)	Duty Cycle (x)	Duty Cycle Factor [10log(1/x)] (dB)
BLE (2Mbps)	0.275	0.625	0.440	3.57

Note: When duty cycle is less than 98% (0.98) that duty cycle factor 10log(1/x) is needed to add in conducted test items measured in average detector.

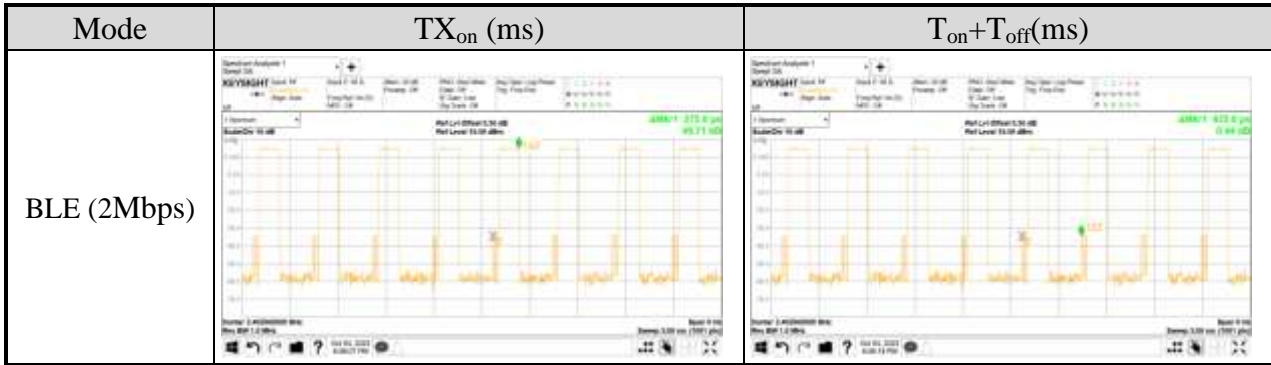

AC Conduction	
SKU #1	Normal operation
SKU #2	Normal operation
SKU #3	Normal operation

Item		Mode	Data Rate	Test Channel
Radiated Test Case	SKU #1	802.11ax-HE20	HE0	7
		BLE	2Mbps	17
	SKU #2	802.11ax-HE20	HE0	7
		BLE	2Mbps	17
	SKU #3	802.11ax-HE20	HE0	7
		BLE	2Mbps	17

Item		Mode	Data Rate	Test Channel	
Radiated Test Case	SKU #1	Radiated Band Edge <sup>Note1</sup>	BLE	2Mbps	39
	SKU #2		BLE	2Mbps	39
	SKU #3		802.11n-HT40	MCS8	9
			BLE	2Mbps	39
	SKU #1	Radiated Spurious Emission <sup>Note1 &amp; 2</sup>	802.11g	6Mbps	7
			BLE	2Mbps	17
	SKU #2		802.11ax-HE20	HE0	7
			BLE	2Mbps	39
	SKU #3		802.11ax-HE40	HE0	7
			BLE	2Mbps	37

Item		Mode	RU Config	Test Channel	
Radiated Test Case	SKU #1	Radiated Band Edge <sup>Note 1</sup>	802.11ax-HE40	242/62	11
	SKU #2		802.11ax-HE40	242/62	11

Item		Mode	Data Rate	Test Channel
Conducted Test Case	SKU #1 SKU #2	802.11b	1Mbps	1/7/8/11/12/13
		802.11g	6Mbps	1/2/7/10/11/12/13
		802.11n-HT20	MCS8	1/2/3/7/10/11/12/ 13
		802.11n-HT40	MCS8	3/7/9/10/11
		802.11ax-HE20	HE0	1/2/7/10/11/12/13
		802.11ax-HE40	HE0	3/7/9/10/11
		BLE	1Mbps	37/17/39
			2Mbps	37/17/39
			PHY Coded S2	37/17/39
			PHY Coded S8	37/17/39
	SKU #3	802.11b	1Mbps	1/7/8/11/12/13
		802.11g	6Mbps	1/2/7/10/11/12/13
		802.11n-HT20	MCS8	1/2/3/7/10/11/12/ 13
		802.11n-HT40	MCS8	3/7/9/10/11
		802.11ax-HE20	HE0	1/2/7/10/11/12/13
		802.11ax-HE40	HE0	3/7/9/10/11
		BLE	1Mbps	37/17/39
			2Mbps	37/17/39
			PHY Coded S2	37/17/39
			PHY Coded S8	37/17/39

Item			Mode	Data Rate	RU Configuration	Test Channel
Conducted Test Case	SKU #1 SKU #2	Peak Output Power (SPOT Check)	802.11ax-HE20	HE0	26/0	1
					52/37	
					106/53	
			802.11ax-HE40	HE0	26/8	13
					52/40	
					106/5	
	SKU #3		802.11ax-HE40	HE0	242/61	3
				HE0	242/62	11
			802.11ax-HE20	HE0	26/0	1
					52/37	
					106/53	
			802.11ax-HE40	HE0	26/8	13
52/40						
106/5						
802.11ax-HE40	HE0	242/61	3			
	HE0	242/62	11			

Note 1:  Mobile Device       Portable Device

and 3 axis were assessed. The worst scenario for Radiated Spurious Emission as follow:

Lie     Side     Stand

Note 2: Low, mid, and high channels were measured, only the worst channel of each modulation was presented in this report.

Note 3: The modulation and bandwidth are similar for 802.11n mode for HT20/HT40 and 802.11ac mode for VHT20/VHT40, therefore investigated worst case to representative mode in the test report.

Note 4: The data rates were selected based on preliminary testing that identified rate as the worst case for output power.



### 3.9. Output Power Setting

For SKU (Mode) 1, 2

Mode	Centre Frequency (MHz)	Power Setting		Mode	Centre Frequency (MHz)	Power Setting	
		AUX	Main			AUX	Main
802.11b	2412	20.000	20.000	802.11g	2412	17.000	17.000
	2442	20.000	20.000		2417	19.000	19.250
	2462	20.000	20.000		2442	20.000	20.000
	2467	19.000	18.750		2457	18.750	18.500
	2472	16.500	15.500		2462	16.750	16.750
					2467	14.500	14.250
			2472	11.500	11.500		

Mode	Centre Frequency (MHz)	Power Setting		Mode	Centre Frequency (MHz)	Power Setting	
		AUX	Main			AUX	Main
802.11n-HT20	2412	14.750	14.750	802.11n-HT40	2422	13.750	13.750
	2417	17.000	17.000		2442	14.750	14.750
	2422	18.250	18.250		2452	13.750	13.750
	2442	20.000	20.000		2457	9.000	9.000
	2457	18.250	18.250		2462	5.500	5.500
	2462	15.000	15.000				
	2467	11.000	11.000				
	2472	6.000	6.000				

Mode	Centre Frequency (MHz)	Power Setting		Mode	Centre Frequency (MHz)	Power Setting	
		AUX	Main			AUX	Main
802.11ax-HE20	2412	14.750	14.750	802.11ax-HE40	2422	13.750	13.750
	2417	17.000	17.000		2442	14.750	14.750
	2422	18.250	18.250		2452	13.750	13.750
	2442	20.000	20.000		2457	9.000	9.000
	2457	18.250	18.250		2462	5.500	5.500
	2462	15.000	15.000				
	2467	11.000	11.000				
	2472	6.000	6.000				

Mode	RU Configuration	Centre Frequency (MHz)	Power Setting	
			AUX	Main
802.11ax-HE20	26/0	2412	17.125	17.125
	52/37		16.750	16.750
	106/53		12.625	12.625
	26/0	2472	5.500	5.500
	52/37		6.000	6.000
	106/53		6.000	6.000
802.11ax-HE40	242/61	2422	15.000	15.000
	242/62	2462	6.000	6.000

Mode	Centre Frequency (MHz)	Power Setting			
		1Mbps	2Mbps	PHY Coded S2	PHY Coded S8
BLE	2402	Default	Default	Default	Default
	2440	Default	Default	Default	Default
	2480	Default	Default	Default	Default

For SKU (Mode) 3

Mode	Centre Frequency (MHz)	Power Setting		Mode	Centre Frequency (MHz)	Power Setting	
		AUX	Main			AUX	Main
802.11b	2412	17.000	17.000	802.11g	2412	17.000	17.000
	2442	17.000	17.000		2417	17.000	17.000
	2462	17.000	17.000		2442	17.000	17.000
	2467	17.000	17.000		2457	17.000	17.000
	2472	16.500	15.500		2462	16.750	16.750
						2467	14.500
				2472	11.500	11.500	

Mode	Centre Frequency (MHz)	Power Setting		Mode	Centre Frequency (MHz)	Power Setting	
		AUX	Main			AUX	Main
802.11n-HT20	2412	14.750	14.750	802.11n-HT40	2422	13.750	13.750
	2417	17.000	17.000		2442	14.750	14.750
	2442	17.000	17.000		2452	13.750	13.750
	2457	17.000	17.000		2457	9.000	9.000
	2462	17.000	17.000		2462	5.500	5.500
	2467	15.000	15.000				
	2472	11.000	11.000				

Mode	Centre Frequency (MHz)	Power Setting		Mode	Centre Frequency (MHz)	Power Setting	
		AUX	Main			AUX	Main
802.11ax-HE20	2412	14.750	14.750	802.11ax-HE40	2422	13.750	13.750
	2417	17.000	17.000		2442	14.750	14.750
	2442	17.000	17.000		2452	13.750	13.750
	2457	17.000	17.000		2457	9.000	9.000
	2462	17.000	17.000		2462	5.500	5.500
	2467	15.000	15.000				
	2472	11.000	11.000				

Mode	RU Configuration	Centre Frequency (MHz)	Power Setting	
			AUX	Main
802.11ax-HE20	26/0	2412	17.000	17.000
	52/37		16.750	16.750
	106/53		12.625	12.625
	26/0	2472	5.500	5.500
	52/37		6.000	6.000
	106/53		6.000	6.000
802.11ax-HE40	242/61	2422	15.000	15.000
	242/62	2462	6.000	6.000

Mode	Centre Frequency (MHz)	Power Setting			
		1Mbps	2Mbps	PHY Coded S2	PHY Coded S8
BLE	2402	Default	Default	Default	Default
	2440	Default	Default	Default	Default
	2480	Default	Default	Default	Default

### 3.10. Tested Supporting System List

#### 3.10.1. Support Peripheral Unit

No.	Product	Brand	Model No.	Serial No.	Approval
1.	LCD Monitor	DELL	U2718Qb	CN-0M5R5F-QD C00-99P-04CL	N/A
2.	USB Mouse	Lenovo	SM-8823	8SSM50L24506A VLC99H049R	N/A
3.	Earphone	APPLE	N/A	N/A	N/A
4.	SD Card	ADATA	MicroSDHC Card	N/A	N/A
<b>Partner System</b>					
5	AP Server	ASUS	RT-AX88U	N/A	FCC ID: MSQ-RTAXHP00 IC: 3568A-RTAXHP00

#### 3.10.2. Cable Lists

No.	Cable Description Of The Above Support Units
1.	HDMI Cable: Shielded, Detachable, 1.8 AC Power Cord: Unshielded, Detachable, 1.8m
2.	USB Cable: Unshielded, Undetachable, 1.8
3.	Earphone Cable: Unshielded, Undetachable, 1.2m
4.	N/A
5.	AC adapter: M/N:WA-30B12, Cable: Unshielded, Detachable, 1.2m LAN cable: Unshielded, Detachable,3.0m
6.	LAN cable: Unshielded, Detachable, 1.8m

### 3.11. Setup Configuration

#### 3.11.1. EUT Configuration for Power Line & Radiated Emission

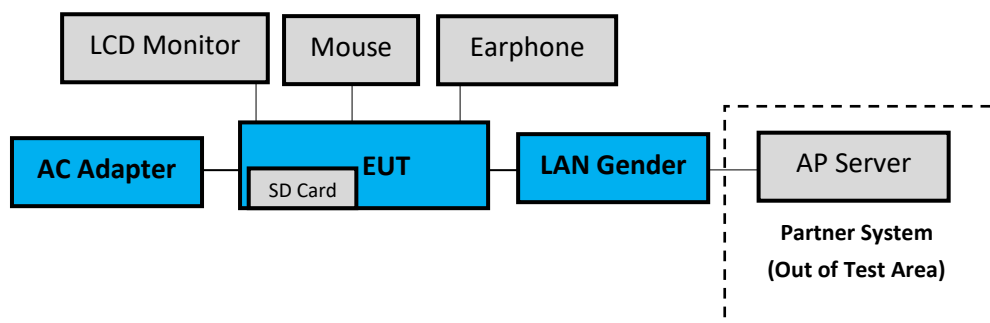

#### 3.11.2. EUT Configuration for RF Conducted Test Items

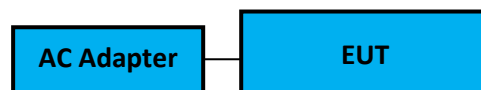

### 3.12. Operating Condition of EUT

Test program “DRTU” is used for enabling EUT BT or WLAN function under continues transmitting and choosing data rate/ channel.

[ANT AUX port (A Button in DRTU), ANT Main port (B Button in DRTU)].

### 3.13. Description of Test Facility

Name of Test Firm	Audix Technology Corporation / EMC Department No. 491, Zhongfu Rd., Linkou Dist., New Taipei City 244, Taiwan Tel: +886-2-26092133 Fax: +886-2-26099303 Website : www.audixtech.com Contact e-mail: attemc_report@audixtech.com
Accreditations	The laboratory is accredited by following organizations under ISO/IEC 17025:2017 (1) NVLAP(USA) NVLAP Lab Code 200077-0 (2) TAF(Taiwan) No. 1724
Test Facilities	FCC OET Designation Number under APEC MRA by NCC is : TW1724 ISED CAB Identifier Number under APEC TEL MRA by NCC is TW1724 (1) No.8 Shielded Room (2) No.1 3m Semi Anechoic Chamber

### 3.14.Measurement Uncertainty

The measurement uncertainty levels have been estimated as specified in ETSI TR 100 028-2001

Test Items/Facilities		Frequency Range	Uncertainty
Conduction Test	<input type="checkbox"/>	No. 7 Shielded Room	9kHz-150kHz ±3.7dB
			150kHz-30MHz ±3.4dB
	<input checked="" type="checkbox"/>	No. 8 Shielded Room	9kHz-150kHz ±3.7dB
			150kHz-30MHz ±3.5dB
Radiation Test	<input checked="" type="checkbox"/>	No.1 3m Semi Anechoic Chamber	30MHz-200MHz, 3m, Horizontal ±3.6dB
			200MHz-1000MHz, 3m, Horizontal ±4.3dB
			30MHz-200MHz, 3m, Vertical ±4.4dB
			200MHz-1000MHz, 3m, Vertical ±4.8dB
			1GHz-6GHz, 3m ±4.8dB
			6GHz-18GHz, 3m ±4.5dB
	<input type="checkbox"/>	No.3 3m Semi Anechoic Chamber	30MHz-200MHz, 3m, Horizontal ±4.0dB
			200MHz-1000MHz, 3m, Horizontal ±4.4dB
			30MHz-200MHz, 3m, Vertical ±4.7dB
			200MHz-1000MHz, 3m, Vertical ±4.5dB
			1GHz-6GHz, 3m ±4.8dB
			6GHz-18GHz, 3m ±4.5dB
	<input type="checkbox"/>	No.4 3m Semi Anechoic Chamber	30MHz-200MHz, 3m, Horizontal ±4.3dB
			200MHz-1000MHz, 3m, Horizontal ±4.2dB
			30MHz-200MHz, 3m, Vertical ±4.8dB
			200MHz-1000MHz, 3m, Vertical ±4.7dB
			1GHz-6GHz, 3m ±4.6dB
			6GHz-18GHz, 3m ±4.4dB
	<input type="checkbox"/>	No.5 3m Semi Anechoic Chamber	30MHz-200MHz, 3m, Horizontal ±4.6dB
			200MHz-1000MHz, 3m, Horizontal ±4.4dB
			30MHz-200MHz, 3m, Vertical ±4.5dB
			200MHz-1000MHz, 3m, Vertical ±4.9dB
			1GHz-6GHz, 3m ±4.9dB
			6GHz-18GHz, 3m ±4.6dB
Radiated emissions (18GHz-40GHz)		18GHz-40GHz, 3m	±3.4dB

Remark : Uncertainty =  $ku_c(y)$

Test Item	Uncertainty
Maximum peak output power	± 0.33dB

## 4. MEASUREMENT EQUIPMENT LIST

### 4.1. Conducted Emission Measurement

Item	Type	Manufacturer	Model No.	Serial No.	Cal. Date	Cal. Interval
1.	Test Receiver	R&S	ESR3	101774	2023. 01. 11	1 Year
2.	A.M.N.	R&S	ENV432	101567	2023. 06. 02	1 Year
3.	L.I.S.N.	Kyoritsu	KNW-407	8-855-9	2022. 12. 19	1 Year
4.	Pulse Limiter	R&S	ESH3-Z2	100354	2022. 12. 14	1 Year
5.	Digital Thermo-Hygro Meter	iMax	HTC-1	No.8 S/R	2023. 04. 13	1 Year
6.	Coaxial Cable	Yeida	RG/58AU	CE-08	2023. 09. 06	1 Year
7.	Test Software	Audix	e3	V9 18621a	N.C.R.	N.C.R.

### 4.2. Radiated Emission Measurement

Item	Type	Manufacturer	Model No.	Serial No.	Cal. Date	Cal. Interval
1.	Spectrum Analyzer	Agilent	N9010A-526	MY53400071	2023.08.16	1 Year
2.	Test Receiver	R&S	ESCS30	100338	2023.06.20	1 Year
3.	Amplifier	HP	8447D	2944A06305	2022.12.29	1 Year
4.	Microwave Amplifier	Keysight	83051A	MY56480113	2023.09.11	1 Year
5.	Microwave Amplifier	Agilent	8449B	3008A02678	2023.02.17	1 Year
6.	Loop Antenna	TESEQ	HLA 6121	60478	2023.02.21	1 Year
7.	Bilog Antenna	TESEQ	CBL6112D	33821	2023.06.30	1 Year
8.	Horn Antenna	EMCO	3115	9609-4927	2023.07.21	1 Year
9.	Horn Antenna	COM-POWER	AH-840	101092	2022.12.30	1 Year
10.	2.4GHz Notch Filter	K&L Microwave	7NSL10-2441.5/ E130.5-O/O	2	2023.07.22	1 Year
11.	3GHz Notch Filter	Microwave	H3G018G1	484796	2023.07.22	1 Year
12.	Coaxial Cable	MIYAZAKI	5D2W	RE-11	2023.01.07	1 Year
13.	Coaxial Cable	HUBER+S UHNER	RG223/U	RE-33	2023.03.02	1 Year
14.	Coaxial Cable	HUBER+SUH NER	SUCOFLEX 106	RE-14	2023.01.07	1 Year
15.	Coaxial Cable	HUBER+SUH NER	SUCOFLEX 102	RE-30	2023.08.21	1 Year
16.	Digital Thermo-Hygro Meter	iMax	HTC-1	No.1 3m A/C	2023.04.13	1 Year
17.	Test Software	Audix	e3	V9 18621a	N.C.R.	N.C.R.

### 4.3. RF Conducted Measurement

Item	Type	Manufacturer	Model No.	Serial No.	Cal. Date	Cal. Interval
1.	Power Meter	Anritsu	ML2495A	2127005	2022. 12. 01	1 Year
2.	Power Meter	Anritsu	ML2495A	2127004	2022. 12. 07	1 Year
3.	Power Sensor	Anritsu	MA2411B	1911360	2022. 12. 07	1 Year
4.	Power Sensor	Anritsu	MA2411B	1911356	2022. 12. 01	1 Year
5.	Digital Thermo-Hygro Meter	iMax	HTC-1	RF-03	2023. 04. 13	1 Year



## 5. CONDUCTED EMISSION

### 5.1. Block Diagram of Test Setup

#### 5.1.1. Block Diagram of EUT

Indicated as section 3.11

#### 5.1.2. Shielded Room Setup Diagram

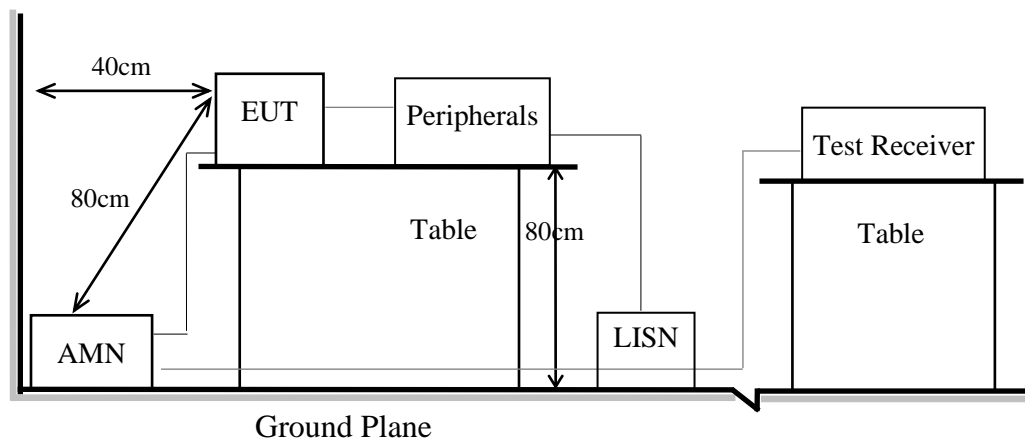

### 5.2. Conducted Emission Limit

Frequency	Conducted Limit	
	Quasi-Peak Level	Average Level
150kHz ~ 500kHz	66 ~ 56 dB $\mu$ V	56 ~ 46 dB $\mu$ V
500kHz ~ 5MHz	56 dB $\mu$ V	46 dB $\mu$ V
5MHz ~ 30MHz	60 dB $\mu$ V	50 dB $\mu$ V

Remark1.: If the average limit is met when using a Quasi-Peak detector, the measurement using the average detector is not required.

2.: The lower limit applies to the band edges.

### 5.3. Test Procedure

- 5.3.1. To set up the EUT as indicated in ANSI C63.10. The EUT was placed on the table which has 80 cm height to the ground and 40 cm distance to the conducting wall.
- 5.3.2. Power supplier of the EUT was connected to the AC mains through an Artificial Mains Network (A.M.N.).
- 5.3.3. The AC power supplies to all peripheral devices must be provided through line impedance stabilization network (L.I.S.N.)
- 5.3.4. Checking frequency range from 150kHz to 30 MHz and record the emission which does not have 20 dB below limit.

### 5.4. Test Results

Please refer to Appendix A.

## 6. RADIATED EMISSION

### 6.1. Block Diagram of Test Setup

#### 6.1.1. Block Diagram of EUT

Indicated as section 3.11

#### 6.1.2. Setup Diagram for 9kHz-30MHz

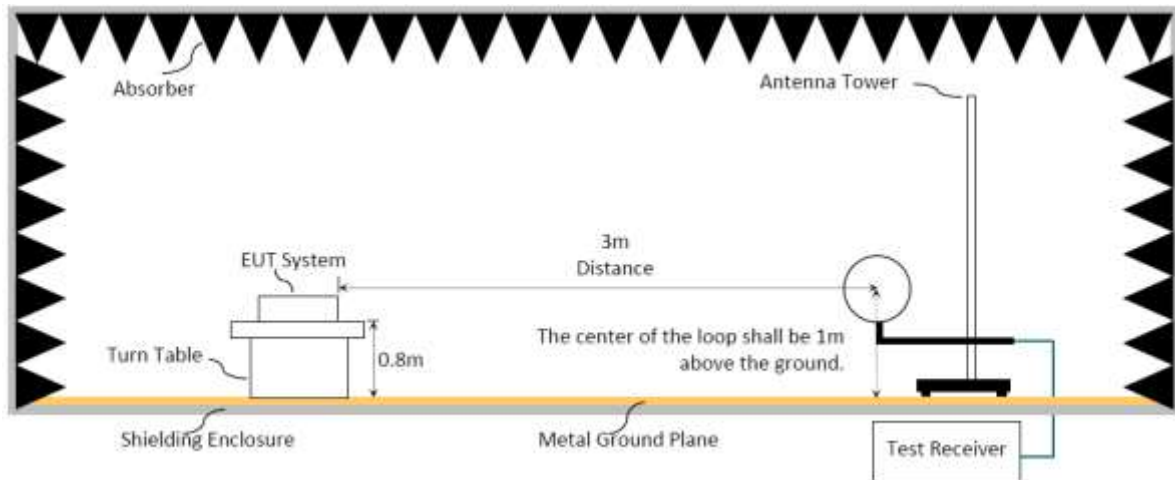

#### 6.1.3. Setup Diagram for 30-1000MHz

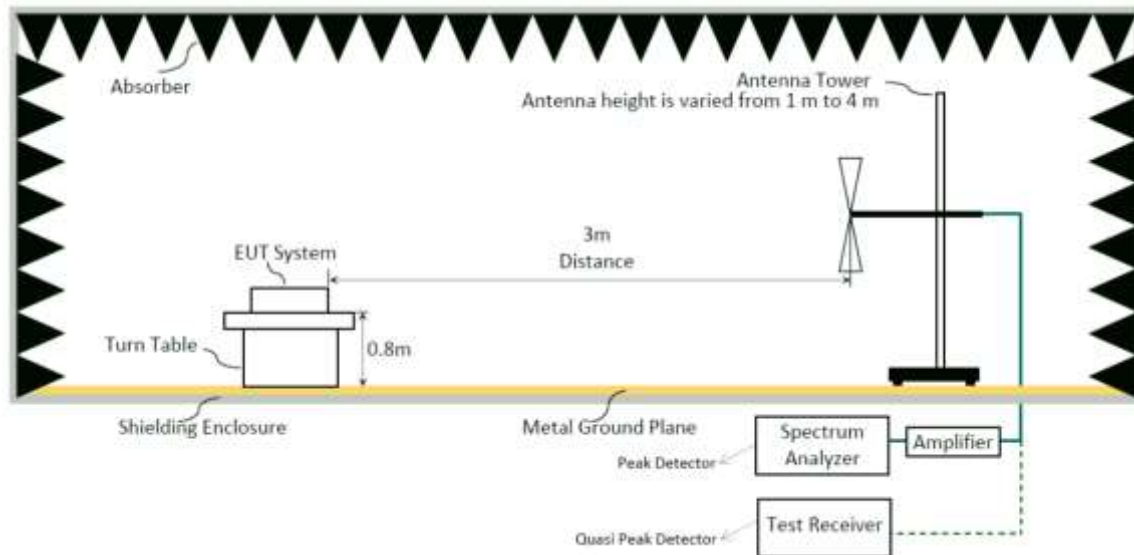

### 6.1.4. Setup Diagram for above 1GHz

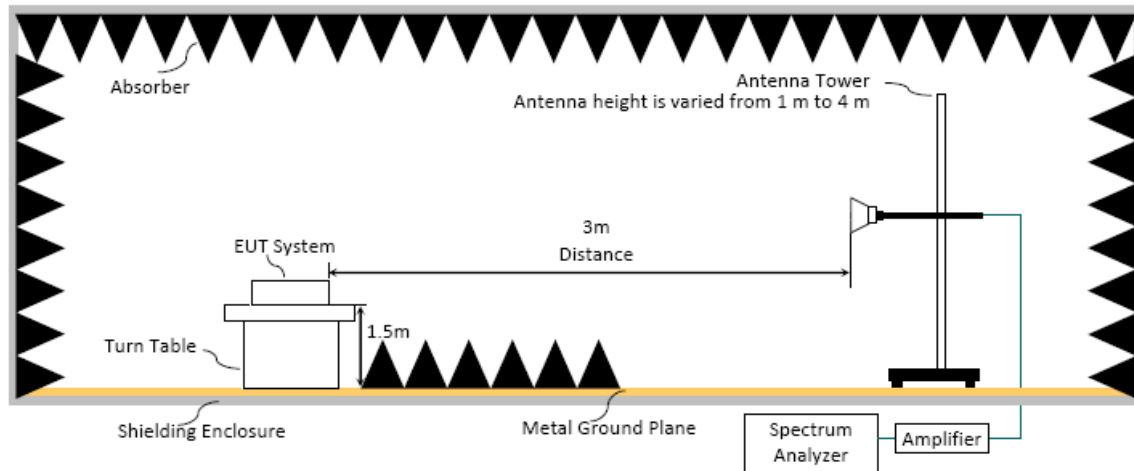

## 6.2. Radiated Emission Limits

In any 100kHz bandwidth outside the frequency band, the radio frequency power produced by the intentional radiator shall be at least 20dB below that in the 100kHz bandwidth within the band that contains the highest level. In addition, radiated emissions which fall in restricted bands, as defined in Section 15.205/RSS-Gen Section 8.10 table 6, must also comply with the radiated emission limits specified as below.

Frequency (MHz)	Distance(m)	Limits	
		dB $\mu$ V/m	$\mu$ V/m
0.009 - 0.490	300	67.6-20 log f(kHz)	2400/f kHz
0.490 - 1.705	30	87.6-20 log f(kHz)	24000/f kHz
1.705 - 30	30	29.5	30
30 - 88	3	40.0	100
88- 216	3	43.5	150
216- 960	3	46.0	200
Above 960	3	54.0	500
Above 1000	3	74.0 dB $\mu$ V/m (Peak) 54.0 dB $\mu$ V/m (Average)	

Remark : (1) dB $\mu$ V/m = 20 log ( $\mu$ V/m)

- (2) The tighter limit applies to the edge between two frequency bands.
- (3) Distance refers to the distance in meters between the measuring instrument antenna and the closed point of any part of the device or system.
- (4) Fundamental and emission fall within operation band are exempted from this section.
- (5) Pursuant to ANSI C63.10: 6.6.4.3, if the maximized peak measured value complies with the average limit, then it is unnecessary to perform an average measurement.

### 6.3. Test Procedure

#### Frequency Range 9kHz~30MHz:

The EUT setup on the turntable which has 0.8 m height to the ground. The turn table rotated 360 degrees and antenna fixed to 1 m to find the maximum emission level. In order to find the maximum emission, all of the interface cables were manipulated according to ANSI C63.10-2013 regulation.

- (1) RBW = 9kHz with peak and average detector.
- (2) Detector: average and peak (9kHz-490kHz)  
Q.P. (490kHz-30MHz)

#### Frequency Range 30MHz ~ 25GHz:

The EUT setup on the turn table which has 80cm (for 30-1000MHz) and 1.5m (for above 1GHz) height to the ground. The turn table rotated 360 degrees and antenna varied from 1 m to 4 m to find the maximum emission level. Both horizontal and vertical polarization are required. In order to find the maximum emission, all of the interface cables were manipulated according to ANSI C63.10-2013 regulation.

#### Frequency below 1GHz:

Spectrum Analyzer is used for pre-testing with following setting:

- (1)RBW = 120KHz
- (2)VBW  $\geq$  3 x RBW.
- (3)Detector = Peak.
- (4)Sweep time = auto.
- (5)Trace mode = max hold.
- (6)Allow sweeps to continue until the trace stabilizes.

Note 1: When peak-detected value is lower than limit that the measurement using the Q.P. detector is not required, otherwise using Q.P. for final measurement.

Note 2: When the radiated emissions limits are expressed in terms of the average value of the emissions, and pulsed operation is employed, the measurement field strength shall be determined by averaging over one complete pulse train, including blanking intervals, as long as the pulse train does not exceed 0.1 seconds.

#### Frequency above 1GHz to 10th harmonic (up to 25 GHz):

##### Peak Detector:

- (1)RBW = 1MHz
- (2)VBW  $\geq$  3 x RBW.
- (3)Detector = Peak.
- (4)Sweep time = auto.
- (5)Trace mode = max hold.
- (6)Allow sweeps to continue until the trace stabilizes.

Note: When peak-detected value is lower than limit that the measurement using the average detector is not required, otherwise using average detector for final measurement.

**Average Detector:**

**Option 1:**

(1) RBW = 1MHz

(2) VBW  $\geq 1/T$ . (Duty Cycle < 98%, when duty cycle presented in section 3.7)

Modulation Type	VBW Setting (VBW $\geq 1/T$ )
BLE (2Mbps)	3.9kHz
802.11ax-HE20 (RU Config 26)	1.5kHz
802.11ax-HE20 (RU Config 52)	750Hz
802.11ax-HE40 (RU Config 242)	750Hz

VBW = 10Hz (Duty Cycle  $\geq 98\%$ , when duty cycle presented in section 3.7)

Modulation Type	VBW Setting
802.11b	10Hz
802.11g	10Hz
802.11n-HT20	10Hz
802.11n-HT40	10Hz
802.11ax-HE20	10Hz
802.11ax-HE40	10Hz
802.11ax-HE20 (RU Config 106)	10Hz

(4) Detector = Peak.

(5) Sweep time = auto.

(6) Trace mode = max hold.

(7) Allow sweeps to continue until the trace stabilizes.

**Option 2:**

Average Emission Level = Peak Emission Level + D.C.C.F.

**6.4. Measurement Result Explanation**

Peak Emission Level (dB $\mu$ V/m) = Antenna Factor (dB/m) + Cable Loss (dB) – Preamp Gain (dB) + Reading (dB $\mu$ V).

Average Emission Level (dB $\mu$ V/m) = Antenna Factor (dB/m) + Cable Loss (dB) – Preamp Gain (dB) + Reading (dB $\mu$ V).

Average Emission Level (dB $\mu$ V/m) = Peak Emission Level (dB $\mu$ V/m) + DCCF (dB)  
 Duty Cycle Correction Factor (DCCF) (dB) =  $20 \log(TX_{on}/TX_{on+off})$  presented in section 3.7.

ERP (dBm) = Peak Emission Level (dB $\mu$ V/m) - 95.2dB - 2.14dB

**6.5. Test Results**

Please refer to Appendix A.

## 7. MAXIMUM PEAK OUTPUT POWER

### 7.1. Block Diagram of Test Setup

- For WLAN Function

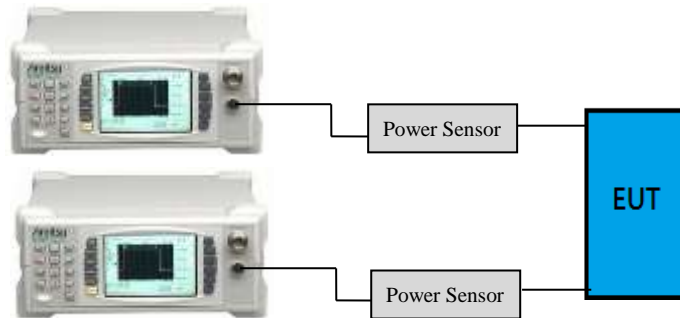

- For BLE Function

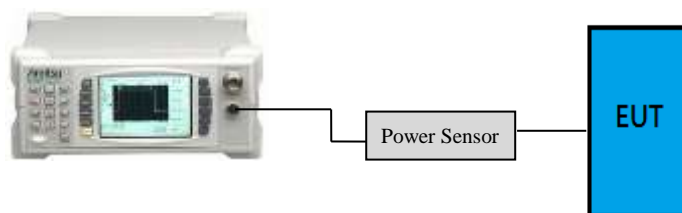

### 7.2. Specification Limits

The Limits of maximum Peak Output Power for digital modulation in 2400-2483.5MHz is : 1Watt. (30dBm), and E.I.R.P.: 4Watt (36dBm)

### 7.3. Test Procedure

Following measurement procedure is reference to ANSI C63.10:2013:

**PKPM1 Peak power meter method:**

EUT is connected to power sensor and record the maximum output power.

**Maximum peak conducted output power method:**

- (1) Set the RBW  $\geq$  DTS bandwidth
- (2) Set VBW  $\geq 3 \times$  RBW
- (3) Set span  $\geq 3 \times$  RBW.
- (4) Sweep time = auto couple
- (5) Detector = peak.
- (6) Trace mode = max hold.
- (7) Allow trace to fully stabilize.
- (8) Use peak marker function to determine the peak amplitude level.

**Method AVGPM (Measurement using an RF average power meter):**

EUT is connected to power sensor and record the maximum average output power and duty cycle factor is added when duty cycle presented in section 3.7 is  $< 98\%$ .

**Method AVGSA-2 (Spectrum channel power)**

- (1) Set span to at least 1.5 times the OBW
- (2) Set RBW = 1 -5% of OBW
- (3) Set the video bandwidth (VBW)  $\geq 3 \times$  RBW.
- (4) Detector = RMS.
- (5) Trace mode = trace average at least 100 traces
- (6) Sweep = auto couple.
- (7) Compute power by integrating the spectrum across the OBW of the signal using the instrument's band power measurement function with band limits set equal to the OBW band edges.
- (8) Duty cycle factor is added when duty cycle presented in section 3.7 is  $< 98\%$ .

### 7.4. Test Results

Please refer to Appendix A

## **8. DEVIATION TO TEST SPECIFICATIONS**

**【NONE】**





# APPENDIX A

## TEST DATA AND PLOTS

(Model: 16Z90S)



# APPENDIX B

## TEST PHOTOGRAPHS

(Model: 16Z90S)