

REV. NO : V0.1

1. SPECIFICATION

MODEL NAME

Rev DATE : '20.12.24

MTVWBE01GLX

1. Features

MTVWBE01GLX is the module for IEEE 802.11a/b/g/n/ac wireless LAN / BT 5.0.

MTVWBE01GLX is based on MEDIATEK MT7668AUN solution.

- IEEE 802.11 a/b/g/n/ac Dual Band Dual Concurrent (DBDC)
- Bluetooth 5.0 + HS, BLE
- Size : 68mm x 30mm x 6.5mm
- Two stream spatial multiplexing
- WLAN / BT metal press antenna on
- Use on-chip OTP (One-Time Programmable)
- Host Interface : USB2.0 (WLAN & BT)
- Security : WAPI, WEP, WPA, WPA2, WMM, AES, TKIP, CKP
- Application: DTV, DVR, HD DVD Player, Blue-ray Disk Player, STB

2. Ordering Information

Model	Description
MTVWBE01GLX	Wi-Fi / BT Module, Dual Band

3. Label Marking

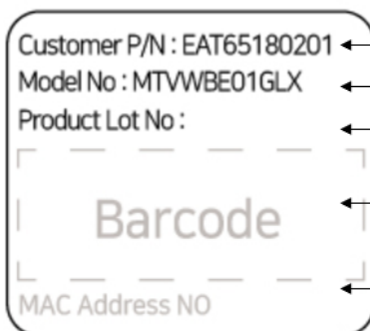

① Customer P/N : EAT65180201

② Model No : MTVWBE01GLX

③ Product Lot No : 법인 생산

Ex) 20CVN170001

20	C	VN	17	0001
(1)	(2)	(3)	(4)	(5)

(1) : Manufactured Year (00~99)

(2) : Manufactured Month (1,2, ...9,A,B,C)

(3) : Vietnam

(4) : Manufactured Date (01~31)

(5) : Manufactured Serial Number (0001~9999)

④ MAC Address BAR Code : 법인 생산

⑤ MAC Address No. : 법인 생산

4. Block Diagram

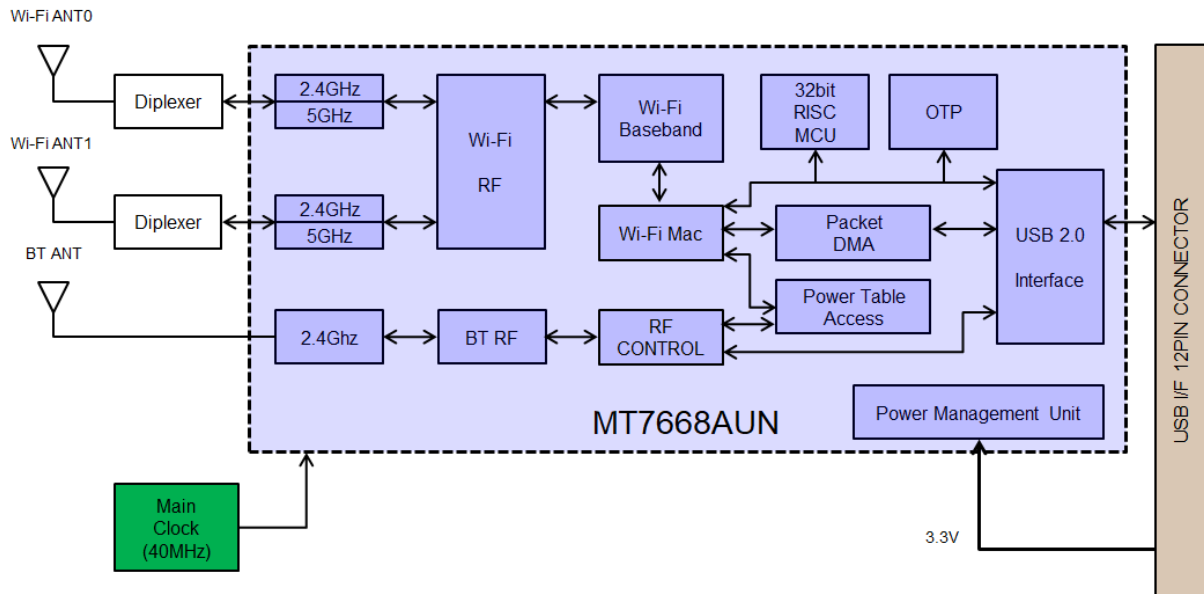

5. Absolute Maximum Ratings

Parameter	MIN	MAX	UNIT
Storage Temperature	-20	+80	°C
Storage Humidity	-	90	%

Caution : The specifications above the Table define levels at which permanent damage to the device can occur. Function operation is not guaranteed under these conditions. Operating at absolute maximum conditions for extend periods can adversely affect the long-term reliability of the device.

- Other conditions

- Do not use or store modules in the corrosive atmosphere, especially where chloride gas, sulfide gas, acid, alkali, salt or the like are contained.
Also, avoid exposure to moisture.
- Store the modules where the temperature and relative humidity do not exceed 5 to 40°C and 20 to 60%.
- Assemble the modules within 6 months.
Check the soldering ability in case of 6 months over

REV. NO : V0.1

1. SPECIFICATION

MODEL NAME

Rev DATE : '20.12.24

MTVWBE01GLX

6. Operating Test Conditions

Parameter	MIN	TYP.	MAX	UNIT
Operating Temperature	0	-	+60	°C
Operating Humidity (40°C)	-	-	85	%
Supply Voltage	3.135	3.3	3.6	Vdc

7. Standard Test Conditions

The Test for electrical specification shall be performed under the following condition
Otherwise this following conditions, not guaranteed this performance.

7-1. Ambient condition

Temperature	25 ± 5 °C
Humidity	65 ± 5%

7-2. Power supply voltages

Input Voltage	Supply Voltage
VDD_3.3V	3.135 ~ 3.6V

REV. NO : V0.1

1. SPECIFICATION

MODEL NAME

Rev DATE : '20.12.24

MTVWBE01GLX

7-3. Current consumption

Description	Spec.	Current (Aver.)	UNIT
2.4G Tx CCK, 11Mbps@21dBm	403	397	mA
2.4G Tx HT20 ,MCS15 @17.5dBm	496	369	
2.4G Tx HT20 ,MCS8 @18dBm	520	506	
5G Tx VHT80 ,MCS9, Nss=2 @15dBm	678	370	
5G Tx VHT80 ,MCS0, Nss=2 @16.5dBm	713	690	

7-4. ESD, ESD Limit Test Information

	MIN	MAX	UNIT
Contact	-	±4	kV
Air	-	±15	

Regulatory Statement (FCC)

- **Part 15.19 Statement**

This device complies with Part 15 of the FCC Rules. Operation is subject to the following two conditions: (1) this device may not cause harmful interference, and (2) this device must accept any interference received, including interference that may cause undesired operation.

- **Part 15.105 Statement (Class B)**

This equipment has been tested and found to comply with the limits for a Class B digital device, pursuant to part 15 of the FCC Rules.

These limits are designed to provide reasonable protection against harmful interference in a residential installation. This equipment generates, uses and can radiate radio frequency energy and, if not installed and used in accordance with the instructions, may cause harmful interference to radio communications. However, there is no guarantee that interference will not occur in a particular installation. If this equipment does cause harmful interference to radio or television reception, which can be determined by turning the equipment off and on, the user is encouraged to try to correct the interference by one or more of the following measures:

- Reorient or relocate the receiving antenna.
- Increase the separation between the equipment and receiver.
- Connect the equipment into an outlet on a circuit different from that to which the receiver is connected.
- Consult the dealer or an experienced radio/TV technician for help.

- **Part 15.21 Statement**

Any changes or modifications not expressly approved by the party responsible for compliance could void the user's authority to operate this equipment. This device must not be co-located or operating in conjunction with any other antenna or transmitter.

- **Responsible Party Information (Supplier's Declaration of Conformity)**

LG Electronics USA
1000 Sylvan Avenue Englewood Cliffs
New Jersey, United States, 07632

Regulatory Statement (FCC)

Regulatory notice to host manufacturer according to KDB 996369 D03 OEM Manual v01

List of applicable FCC rules

This module has been granted modular approval as below listed FCC rule parts.

- FCC Rule parts 15C(15.247,15.407)

Summarize the specific operational use conditions

The OEM integrator should use equivalent antennas which is the same type and equal or less gain than an antenna listed in this instruction manual.

RF exposure considerations

The module has been certified for integration into products only by OEM integrators under the following condition:

-The antenna(s) must be installed such that a minimum separation distance of at least 20 cm is maintained between the radiator (antenna) and all persons at all times.

-The transmitter module must not be co-located or operating in conjunction with any other antenna or transmitter except in accordance with FCC multi-transmitter product procedures.

-Mobile use

As long as the three conditions above are met, further transmitter testing will not be required.

OEM integrators should provide the minimum separation distance to end users in their end-product manuals.

Regulatory Statement (FCC)

- **Antennas list**

This module is certified with the following integrated antenna.

-Type: Metal Press Antenna

-Max. peak Antenna gain

1) ANT 1: -0.73 dBi (2412-2472MHz)/1.26 dBi (UNII-1)/2.92 dBi(UNII-2A)/

3.29 dBi(UNII-2C)/1.48 dBi(UNII-3)

2) ANT 2: -0.04 dBi (2412-2472MHz)/1.83 dBi (UNII-1)/1.83 dBi(UNII-2A)/

1.84 dBi(UNII-2C)/1.68 dBi(UNII-3)

3) BT Ant: 1.51 dBi (2402-2480 MHz)

Any new antenna type, higher gain than listed antenna should be met the requirements of FCC rule 15.203 and 2.1043 as permissive change procedure.

- **Label and compliance information**

End Product Labeling

The module is labeled with its own FCC ID and IC Certification Number. If the FCC ID and IC Certification Number are not visible when the module is installed inside another device, then the outside of the device into which the module is installed must also display a label referring to the enclosed module. In that case, the final end product must be labeled in a visible area with the following:

- Contains FCC ID: BEJMTVWBE01GLX

- Contains IC: 2703H-MTVWBE01GLX

- **Information on test modes and additional testing requirements**

OEM integrator is still responsible for testing their end-product for any additional compliance requirements required with this module installed (for example, digital device emissions, PC peripheral requirements, additional transmitter in the host, etc.).

- **Additional testing, Part 15 Subpart B disclaimer**

The final host product also requires Part 15 subpart B compliance testing with the modular transmitter installed to be properly authorized for operation as a Part 15 digital device.

REG. DATE : 2021.4.21

USER MANUAL

REV.NO : 1.0

REV. DATE : 2021.4.21

 MODEL NAME : **ETWCERBC01 (LGIT)**
LGSBWAC22 (LGE)

PAGE : 15 / 16

Regulatory Statement (ISED)

RSS-GEN, Sec. 7.1.3—(licence-exempt radio apparatus)

This device complies with Industry Canada licence-exempt RSS standard(s). Operation is subject to the following two conditions:

- (1) this device may not cause interference, and
- (2) this device must accept any interference, including interference that may cause undesired operation of the device.

Le présent appareil est conforme aux CNR d'Industrie Canada applicables aux appareils radio exempts de licence. L'exploitation est autorisée aux deux conditions suivantes :

- (1) l'appareil ne doit pas produire de brouillage, et
- (2) l'utilisateur de l'appareil doit accepter tout brouillage radioélectrique subi, même si le brouillage est susceptible d'en compromettre le fonctionnement.

RF Exposure

The antenna (or antennas) must be installed so as to maintain at all times a distance minimum of at least 20 cm between the radiation source (antenna) and any individual. This device may not be installed or used in conjunction with any other antenna or transmitter.

l'exposition aux RF

L'antenne (ou les antennes) doit être installée de façon à maintenir à tout instant une distance minimum de au moins 20 cm entre la source de radiation (l'antenne) et toute personne physique.

Étiquetage du produit final (IC)

Le module MTVWBE01GLX est étiqueté avec sa propre identification FCC et son propre numéro de certification IC. Si l'identification FCC et le numéro de certification IC ne sont pas visibles lorsque le module est installé à l'intérieur d'un autre dispositif, la partie externe du dispositif dans lequel le module est installé devra également présenter une étiquette faisant référence au module inclus. Dans ce cas, le produit final devra être étiqueté sur une zone visible avec les informations suivantes : Contient module émetteur identification FCC ID: BEJMTVWBE01GLX
 Contient module émetteur IC : 2703H-MTVWBE01GLX