

7. SAR Measurement System Validation

7.1 Introduction

This section provides procedures for the following three levels of SAR measurement system verification:

- a) System performance checking
- b) System validation
- c) Interlaboratory comparison.

The objectives and applications of these different levels of verification procedures are as follows:

System performance checking (system check) provides a simple, fast, and reliable test method that can be performed daily or before every SAR measurement. The objective here is to ascertain that the system components are still within laboratory calibration limits, including drift effects. This test requires a flat phantom and a Standard Source, e.g., a half-wave dipole.

*System validation*¹ provides means of system-level validation. The test system utilizes a flat phantom and a reference dipole (see Annex F). Thus, *system validation* verifies the system accuracy against its specifications and does not include the uncertainty due to the use of anthropomorphic phantoms nor does it include the uncertainty due to handset positioning variability. This test is performed annually (e.g., after probe calibration), before measurements related to interlaboratory comparison, and every time modifications have been made to the system, such as a new software release, different readout electronics or different types of probes.

Interlaboratory comparisons provide laboratories with a reference handset and a standard anthropomorphic phantom to quantify the global measurement uncertainty. This allows the data scatter due to the human-like phantom and due to handset positioning effects to be evaluated. This test is used to compare the accuracy and precision performance of various laboratories.

7.2 System Performance Check

7.2.1 Purpose

The purpose of the system performance check (*system check*) is to verify that the system operates within its specifications. The *system check* is a simple check of repeatability to make sure that the system works correctly at the time of the compliance test. It is not a verification of the system with respect to external standards. The *system check* should detect possible short time drift and errors in the system, such as:

- a) changes in the liquid parameters (e.g. due to water evaporation or temperature change)
- b) component failures
- c) component drift

¹ In other international standards (e.g., CENELEC, IEC), the term System Validation may be used to refer to tests using reference handsets with the standard anthropomorphic phantom.

- d) operator errors in the setup or software parameters
- e) adverse conditions in system configuration

The *system check* is a complete 1 g or 10 g averaged SAR measurement in a simplified test system with a standard source (see 7.2.3). The instrumentation and procedures in the *system check* are the same as those used for the compliance tests. The *system check* must be performed using the same liquid as in the compliance test and at a chosen fixed frequency that is within $\pm 10\%$ of the compliance test mid-band frequency. The *system check* is performed prior to compliance tests and the result must always be within $\pm 10\%$ of the target value corresponding to the test frequency, liquid and the source used. The target values are 1 g or 10 g averaged SARs measured by any system on which *system validation* has been performed using the *system check* test system in Figure 7.1. These target values should be determined using a controlled standard source.

7.2.2 Phantom

The test system uses a flat phantom as specified in 4.5.3.

7.2.3 Standard Source

The phantom should be irradiated using a standard source for the required frequency (e.g., a half-wave dipole or patch antenna). The reference dipoles used for *system validation* (see Annex F) can also be used for the *system check*, but are not required. To ensure good SAR measurement repeatability, standard sources should be selected with good positioning repeatability, mechanical and electrical stability, and impedance matching. The standard source should have a return loss better than -20 dB (measured in the test system) at the test frequency to reduce the uncertainty in the power measurement. In the following positioning instructions, a half-wave dipole is used as an example of a standard source.

A half-wave dipole should be positioned below the bottom of the phantom and centered with its axis parallel to the longest side of the phantom. The distance between the liquid filled phantom bottom surface and the dipole center, s , (see Fig. 7.1) should be specified for each test frequency. A low loss and low dielectric constant spacer should be used to establish the correct distance between the top surface of the dipole and the bottom surface of the phantom. For other standard sources, the distance s should be defined according to the source structure. To ensure good repeatability, the same dipoles (or other controlled sources) and spacers shall always be used for *system check*. The acceptable tolerance of distance s should be within ± 0.2 mm.

7.2.4 Standard Source Input Power Measurement

The uncertainty of the power to the source must be as small as possible. This requires the use of a test system with directional couplers and power meters during the *system check*. The recommended test system is shown in Figure 7.1 (which uses a half-wave dipole as an example of a standard source).

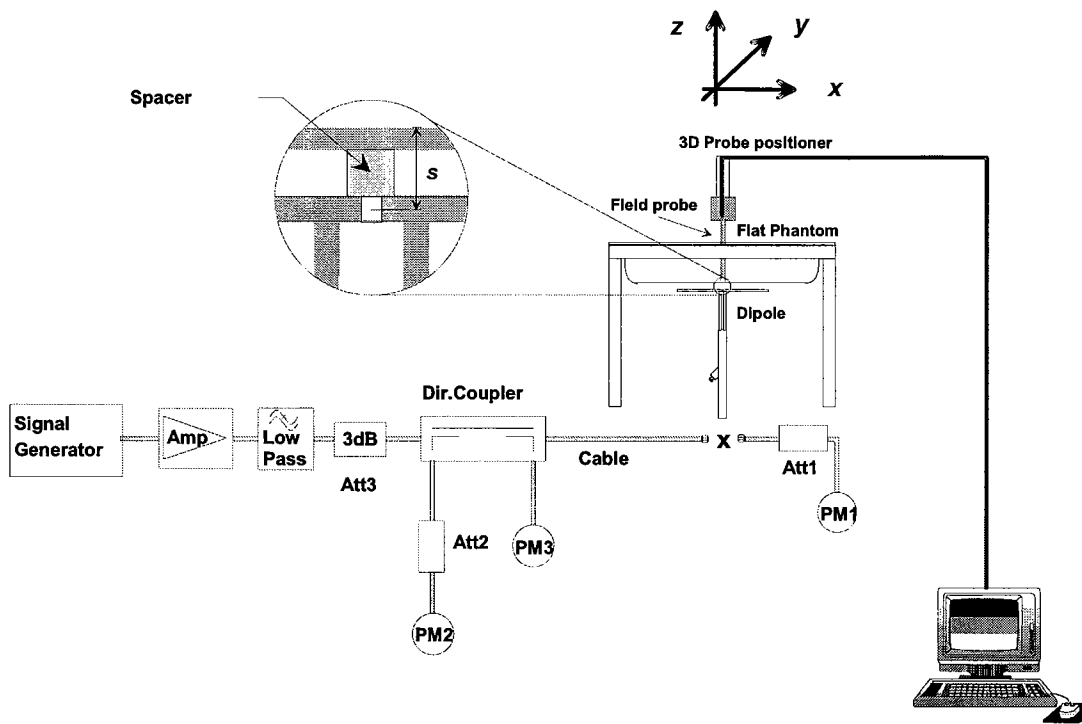

Figure 7.1 – Test system for the system performance check

First the power meter PM1 (including attenuator Att1) is connected to the cable to measure the forward power at the location of the dipole connector (X). The signal generator is adjusted for the desired forward power at the dipole connector (taking into account the attenuation of Att1) as read by power meter PM2. After connecting the cable to the dipole, the signal generator is readjusted for the same reading at power meter PM2. If the signal generator does not allow adjustment in 0.01dB steps, the remaining difference at PM2 must be taken into consideration (e.g., by scaling the measured SAR values versus the forward power difference). PM3 records the reflected power from the dipole to ensure that the reflected power is at least 20dB below the forward power.

The component and instrumentation requirements are as follows:

- The signal generator and amplifier should be stable to within 2 % (short term stability after warm-up). The forward power to the dipole should be high enough to produce SAR exceeding the lower detection limit of the probe system (see Annex A4). The recommended 1 g averaged SAR range is 0.4-8 W/kg. If the signal generator can deliver 15 dBm or more, an amplifier is generally not necessary. Some high power amplifiers should not be operated at a level far below their maximum output power, e.g., a 100 W power amplifier operated at 250 mW output power can be quite noisy. An attenuator between the signal generator and amplifier is recommended to protect the amplifier input.

- b) The low pass filter inserted after the amplifier reduces the effect of harmonics and noise from the amplifier. For most amplifiers in normal operation the filter is not necessary.
- c) The attenuator after the amplifier improves the source matching and the accuracy of the power sensor. (Consult the power meter manual.)
- d) The directional coupler (recommended -20 dB coupling coefficient) is used to monitor the forward power and adjust the signal generator output for constant forward power. A medium-quality coupler is sufficient because the loads (dipole and power head) are both well-matched.
- e) The power meters PM2 and PM3 should have low drift and a resolution of 0.01 dBm, but otherwise the accuracy has negligible impact on the power setting. (Absolute calibration is not required.)
- f) The power meter PM1 and attenuator Att1 must be high-quality components. These should be calibrated, preferably together. The attenuator (-10 dB) improves the accuracy of the power reading. (Some high-power heads come with a built-in calibrated attenuator.) The exact attenuation of the attenuator at the test frequency must be known; many attenuators vary up to 0.2 dB from the specified value.
- g) Use the same power level for PM1 test as used for the actual measurement to avoid linearity and range switching errors in the power meters PM2 and PM3. If the power level is changed, the power level setting procedure should be repeated.
- h) The dipole must be connected directly to the cable at location "X". If the power meter has a different connector system, use high-quality adapters.

7.2.5 System Check Procedure

The *system check* is a complete 1 g or 10 g averaged SAR measurement. The measured 1 g (or 10 g) averaged SAR value is normalized to the target input power of the standard source and compared with the previously recorded target 1 g (or 10 g) value corresponding to the measurement frequency, the Standard Source and specific phantom. The acceptable tolerance must be determined for each *system check* and should be within $\pm 10\%$ of previously recorded *system check* target values.

7.3 System Validation

7.3.1 Purpose

The *system validation* procedure tests the system against reference SAR values, and the performance of probe, readout electronics and software. The test system utilizes a flat phantom and a reference dipole. Thus, the *system validation* process does not include data scatter due to the use of anthropomorphic phantoms, or uncertainty due to handset positioning variability.

System validation is performed annually, when a new system is put into operation, or whenever modifications have been made to the system, such as a new software release, different readout electronics or different types of probes. *System validation* should be done after the probe calibration has taken place.

The objective of this clause is to provide a methodology for SAR measurement verification. Since SAR measurement equipment and calibration techniques can vary widely between various

laboratories, a validation methodology is needed to verify the system accuracy against its specifications. Numerically calculated reference SAR values are listed in Table 7.1.

7.3.2 Phantom

The flat phantom described for the system performance check (see Figure 7.1) is also used for the *system validation* tests. The *system validation* must be performed using head tissue equivalent liquids having dielectric properties as defined in Table 4.1.

7.3.3 Reference Dipole Source

The phantom should be irradiated using a reference dipole specified in Annex F for the required frequency. The reference dipoles are defined for the specific phantom shell dielectric parameters and thickness indicated in Table 7.2. The reference dipole should be positioned below the bottom of the phantom and centered with its axis parallel to the longest side of the phantom. A low loss and low dielectric constant spacer can be used to establish the correct distance between the top surface of the reference dipole and the bottom surface of the phantom. The spacer should not change the measured 1 g and 10 g averaged SAR values more than 1 %. The distance between the liquid filled phantom bottom surface and the reference dipole center (designated s) is specified within 0.2 mm for each test frequency. The reference dipole should have a return loss better than -20 dB (measured in the test system) at the test frequency to reduce the uncertainty in the power measurement.

For the reference dipoles described in Annex F, the spacing distance s is given by:

- a) $s = 15\text{mm} \pm 0.2 \text{ mm}$ for $300 \text{ MHz} \leq f \leq 1000 \text{ MHz}$:
- b) $s = 10\text{mm} \pm 0.2 \text{ mm}$ for $1000 \text{ MHz} < f \leq 3000 \text{ MHz}$

The reference dipole arms shall be parallel to the flat surface of the phantom within a tolerance of ± 2 degrees or less (see Figure 7.1). This can be assured by carefully positioning the empty phantom and the reference dipole to horizontal level using a waterpas.

7.3.4 Reference Dipole Input Power Measurement

The input power measurement test system described for the system performance check (7.2.4) is also used for *system validation* tests.

7.3.5 System Validation Procedure

System validation is used for verifying the accuracy of the probe and readout electronics, and performance of the software. Device positioning and head phantom shape errors are not considered. The *system validation* procedure consists of six steps. Step (a) is the most important part of the *system validation* procedure and shall be done every time. Steps (b)-(f) (recommended) offer a means for quick and simple validation of probe, readout electronics, and software performance. These additional tests should be done any time system components have been modified (e.g., new software release, new readout electronics, new probe type, etc.). The *system validation* procedure is as follows:

- a) **SAR evaluation:** A complete 1 g or 10 g averaged SAR measurement is performed. The reference dipole input power is adjusted to produce a 1 g averaged SAR value falling in the range of 0.4 W/kg to 8 W/kg. The 1 g or 10 g averaged SAR is measured at frequencies in Table 7.1 within the range to be used in compliance tests. The results are

normalized to 1 W forward input power and compared with the reference SAR value for the reference dipole and flat phantom shown in columns 2 and 3 of Table 7.1. The difference from the reference value given in Table 7.1 should be less than the standard uncertainty determined in Clause 6 (Table 6.2).

- b) **Extrapolation routine:** Local SAR values are measured along a vertical axis directly above the Reference Dipole feed point using the same point spacing as used for the evaluation of the peak spatial average SAR. This measurement is repeated along another vertical axis with a 2 cm horizontal offset (y direction – see Fig. 7.1) along the dipole from the reference dipole feed point. SAR values at the phantom surface are extrapolated and compared with the numerical values given in columns 4 and 5 of Table 7.1. The difference from the reference values given in Table 7.1 should be less than the extrapolation standard uncertainty item in Table 6.2.
- c) **Probe linearity:** The measurements in step (a) are repeated using different reference dipole input power levels. The power levels are selected for each frequency are selected to produce 1 g averaged SAR values of approximately 8 W/kg, 1.6 W/kg, and 0.4 W/kg. The measured SAR values are normalized to 1 W forward input power and compared with the 1 W normalized values from step (a). The difference between these values should be less than the probe linearity standard uncertainty item in Table 6.2.
- d) **Modulation response:** The measurements in step (a) are repeated with pulse-modulated signals having a duty factor of 0.1 and pulse repetition rate of 10 Hz. The power is adjusted to produce a 1 g-averaged SAR of approximately 8 W/kg with a CW signal. The measured SAR values are normalized to 1 W forward input power and duty factor of 1, and compared with the 1 W normalized values from step (a). The difference between these values should be less than the linearity standard uncertainty item in Table 6.2.
- e) **System offset:** The measurements in (a) are repeated with a reference dipole input forward power that produces a 1 g averaged SAR of approximately 0.05 W/kg. The measured SAR values are normalized to 1 W forward input power and compared with the 1 W normalized values from step (a). The difference between these values should be less than the probe linearity standard uncertainty item in Table 6.2.
- f) **Probe axial isotropy:** The probe is placed directly above the reference dipole center at a measurement distance of approximately 5 mm from the phantom inner surface. The probe (or reference dipole) is rotated around its axis at least 180° in steps no larger than 15° . The maximum and minimum SAR readings are recorded. The difference between these values should be less than the probe axial isotropy standard uncertainty item in Table 6.2.

NOTE: The *system validation* is neither an alternative procedure to the probe calibration nor to the uncertainty assessment of Clause 6. The probe and the readout electronics shall be calibrated regularly according to the procedures given in Clause 3 and Annex A. Probe hemispherical isotropy is not considered in the test system for *system validation*.

7.3.6 Reference SAR values

In the *system validation* test, the reference dipole constructed for the frequency f_i (described in Annex F) should produce the numerical reference peak spatial-average SAR values shown in columns 2 and 3 of Table 7.1, within the uncertainty of the system. Columns 4 and 5 of Table 7.1 are used to validate the system extrapolation routines, as described in 7.3.5. The reference SAR values have been calculated using the finite-difference time-domain method [Yee, 1966]. The values in columns 4 and 5 for frequencies between 835 and 3000 MHz have been experimentally

verified by using 4th-order polynomial extrapolation [to be determined]. The values for frequencies between 300 and 450 MHz will be experimentally verified in the next revision of the standard. The parameters for the lossless phantom shell used in the simulations (dimensions, shell thickness and permittivity), and the distance s between the reference dipole and liquid are given in Table 7.2. The dielectric properties used for the liquid are defined in Table 4.1 and the dimensions of the reference dipoles are shown in Table F1.

Table 7.1 – Numerical reference SAR values for reference dipole and flat phantom. All values are normalized to a forward power of 1 W.

Frequency (MHz)	1 g SAR	10 g SAR	local SAR at surface (above feedpoint)	local SAR at surface (y=2cm offset from feedpoint)
300	3.0	2.0	4.4	2.1
450	4.9	3.3	7.2	3.2
835	9.5	6.2	14.1	4.9
900	10.8	6.9	16.4	5.4
1450	29.0	16.0	50.2	6.5
1800	38.1	19.8	69.5	6.8
1900	39.7	20.5	72.1	6.6
2000	41.1	21.1	74.6	6.5
2450	52.4	24.0	104.2	7.7
3000	63.8	25.7	140.2	9.5

Table 7.2 – Parameters used for calculation of reference SAR values in Table 7.1

Frequency (MHz)	Phantom shell thickness (mm)	Phantom shell permittivity	Phantom dimensions (mm) x, y, z	Reference dipole distance s (mm) from the liquid
300	6.3	3.7	1000, 800, 170	15
450	6.3	3.7	700, 600, 170	15
835	2.0	3.7	360, 300, 150	15
900	2.0	3.7	360, 300, 150	15
1450	2.0	3.7	240, 200, 150	10
1800	2.0	3.7	220, 160, 150	10

File : c:/idx3/SYSTEM/SARMEAS3/data/Normal/01121040_ZOOM.VLT
Start : 10-Dec-101 03:46:18 pm End : 10-Dec-101 04:01:34 pm

Radio Type : Validation
Model Number :
Serial Number : C
Frequency : 1900 MHz
Peak Trans. Pwr : 0.250 W
Start Trans. Pwr : 0.250 W
Antenna Type : Dipole
Antenna Posn. : Internal
Phantom Type : Flat
Phantom Posn. : E Field
Scan Type : ZOOM/SAR
Probe Name : PCTEST
Field Type : E Field
Orientation : 0 Degrees

Mixture Type = Brain
Mixture Dielectric Constant = 39.900
Mixture Conductivity = 1.420

Comment :
1900 MHz Brain Validation
SN: C

Robot : PCTEST

Probe Offset = 0.20 cm
Sensor Factor = 0.0108
Conversion Factor = 0.550

PCTEST Amplifier Channel Settings : 0.309 0.361 0.421

Max Location : X = 1.750, Y = -2.000, Z = 0.000 (cm) Value = 265.451

Measured Values (volts) =
2.439E-001 1.418E-001 9.500E-002 6.119E-002 4.488E-002 3.028E-002
2.141E-002 1.482E-002 1.059E-002 7.997E-003 6.023E-003 4.263E-003
3.083E-003 3.224E-003 2.444E-003 1.628E-003 1.172E-003 1.014E-003
1.043E-003 1.255E-003 1.262E-003

Calc. Voltage @ Surface (Vs) = 0.3564

Voltage @ 1.00 cm (Vt) = 0.0579

Ave. Voltage (Vs+Vt)/2 = 0.2072

Ave. SAR over 1 g (mW/g) = 10.5493

SAR Scan
File : 01121040_ZOOM
Start : 10-Dec-101 03:46:18 pm End : 10-Dec-101 04:01:34 pm
Validation//C;1900MHz;W;Dipole/Internal;
Flat/E Field;ZOOM/SAR;PCTEST/E Field/0 DegreesBrain/39.900/1.420

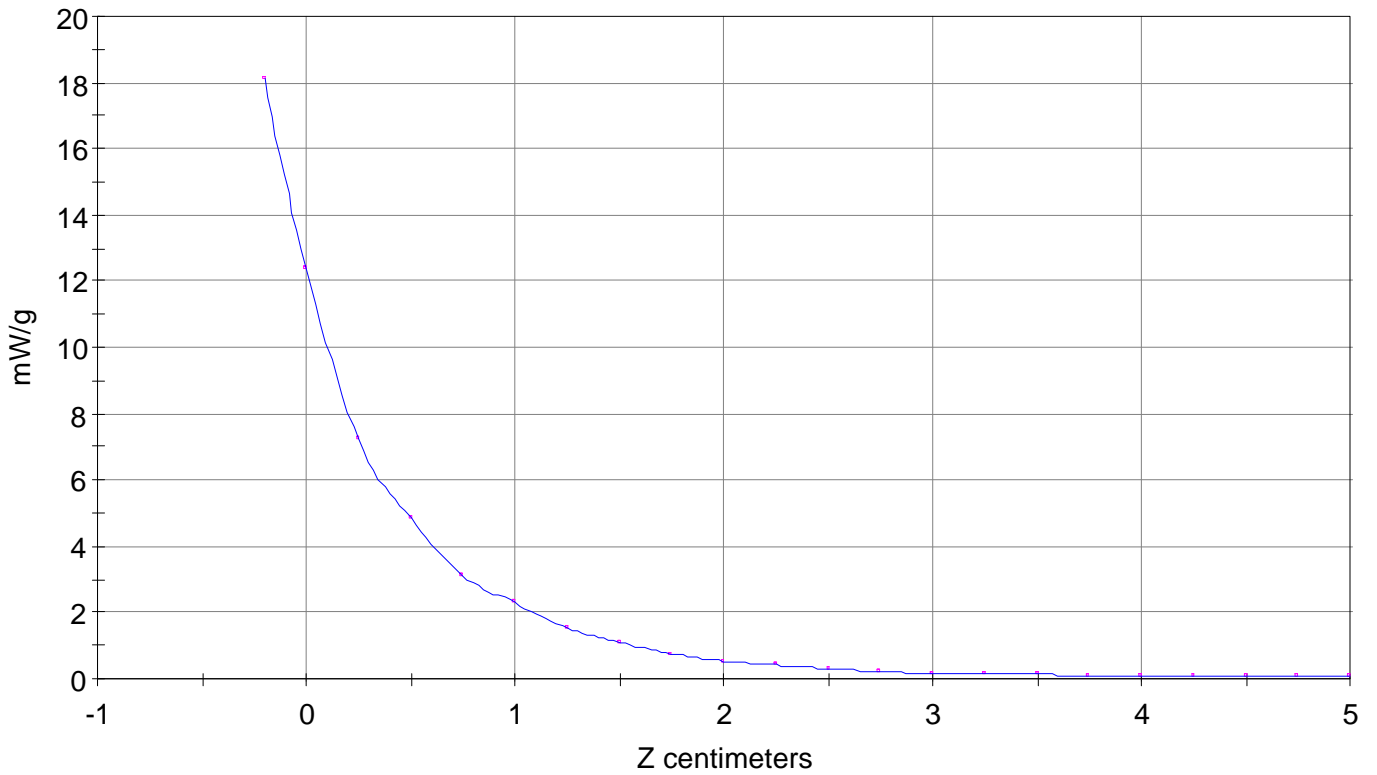

File : 01121040_ZOOM

Start : 10-Dec-101 03:46:18 pm End : 10-Dec-101 04:01:34 pm

Validation//C;1900MHz;W;Dipole/Internal;

Flat/E Field;ZOOM/SAR;PCTEST/E Field/0 DegreesBrain/39.900/1.420

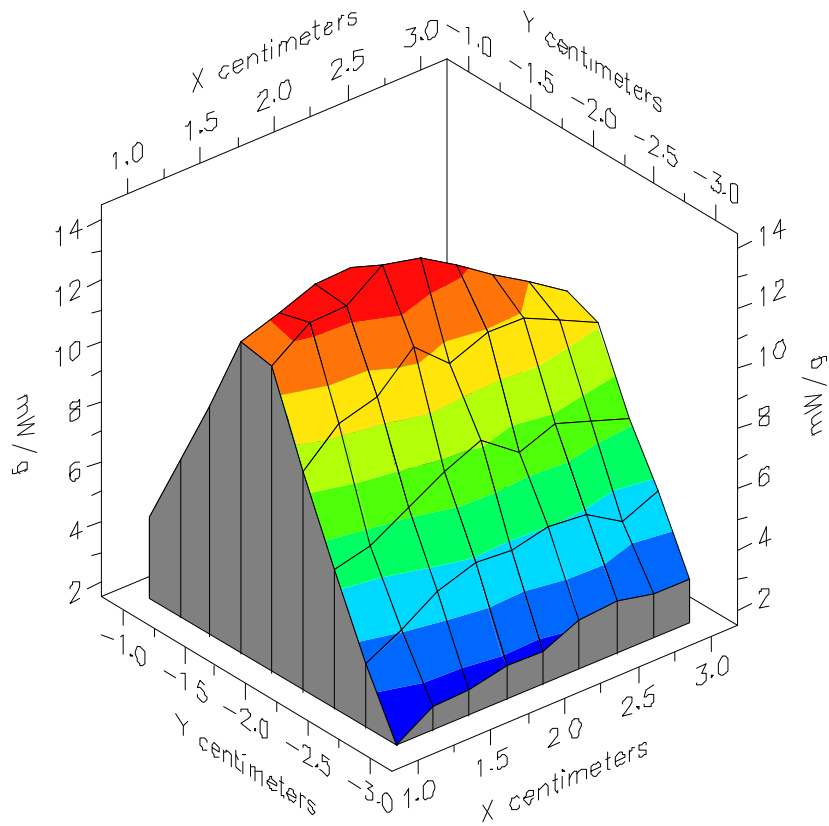

File : 01121040_ZOOM

Start : 10-Dec-101 03:46:18 pm End : 10-Dec-101 04:01:34 pm

Validation//C;1900MHz;W;Dipole/Internal;

Flat/E Field;ZOOM/SAR;PCTEST/E Field/0 DegreesBrain/39.900/1.420

