

***FCC 15.247 & RSS-247
2.4 GHz Report***

for

LG Electronics Inc.

222 LG-ro Jinwi-myeon 451-713
Pyeongtaek-si, Gyeonggi-do 451-713, Korea

Brand : GM
**Product Name : Silver box RADIO
ASM-RECEIVER**
Model Name : LC10S-B
FCC ID : BEJLC10SB
IC : 2703H-LC10SB

TABLE OF CONTENTS

Description	Page
TEST REPORT CERTIFICATION	4
1. REPORT HISTORY.....	5
2. SUMMARY OF TEST RESULTS	6
3. GENERAL INFORMATION	7
3.1. Description of EUT	7
3.2. EUT Specifications Assessed in Current Report	8
3.3. Antenna Information	9
3.4. Test Configuration	9
3.5. Tested Supporting System List	10
3.6. Setup Configuration	10
3.7. Operating Condition of EUT	10
3.8. Description of Test Facility	11
3.9. Measurement Uncertainty	11
4. MEASUREMENT EQUIPMENT LIST.....	12
4.1. Radiated Emission Measurement	12
4.2. RF Conducted Measurement	12
5. RADIATED EMISSION MEASUREMENT	13
5.1. Block Diagram of Test Setup	13
5.2. Radiated Emission Limits	14
5.3. Test Procedure	14
5.4. Measurement Result Explanation	15
5.5. Test Results.....	15
6. 20dB BANDWIDTH MEASUREMENT	24
6.1. Block Diagram of Test Setup	24
6.2. Specification Limits	24
6.3. Test Procedure	24
6.4. Test Results.....	24
7. CARRIER FREQUENCY SEPARATION MEASUREMENT	25
7.1. Block Diagram of Test Setup	25
7.2. Specification Limits	25
7.3. Test Procedure	25
7.4. Test Results.....	25
8. TIME OF OCCUPANCY MEASUREMENT.....	26
8.1. Block Diagram of Test Setup	26
8.2. Specification Limits	26
8.3. Test Procedure	26
8.4. Test Results.....	26
9. NUMBER OF HOPPING CHANNELS MEASUREMENT	27
9.1. Block Diagram of Test Setup	27
9.2. Specification Limits	27
9.3. Test Procedure	27
9.4. Test Results.....	27
10. MAXIMUM PEAK OUTPUT POWER MEASUREMENT	28

10.1. Block Diagram of Test Setup	28
10.2. Specification Limits	28
10.3. Test Procedure	28
10.4. Test Results	28
11. EMISSION LIMITATIONS MEASUREMENT	29
11.1. Block Diagram of Test Setup	29
11.2. Specification Limits	29
11.3. Test Procedure	29
11.4. Test Results	29
12. DEVIATION TO TEST SPECIFICATIONS.....	30

APPENDIX A TEST PLOTS
APPENDIX B TEST PHOTOGRAPHS

TEST REPORT CERTIFICATION

Applicant : LG Electronics Inc.
Manufacture : LG Electronics Inc.
Factory : LG ELECTRONICS VIETNAM HAI PHONG CO., LTD.
Product Name : Silver box RADIO ASM-RECEIVER
Model No. : LC10S-B
Serial No. : N/A
Brand : GM

Applicable Standards:

FCC Rules and Regulations Part 15 Subpart C, Oct. 2014
RSS-Gen (Issue 4), November 2014
RSS-247 (Issue 1), May 2015
ANSI C63.10:2013
FCC Public Notice DA 00-705

AUDIX Technology Corp. tested the equipment mentioned in accordance with the requirements set forth in the above standards. Test results indicate that the equipment tested is capable of demonstrating compliance with the requirements as documented within this report. **AUDIX Technology Corp.** does not assume responsibility for any conclusions and generalizations drawn from the test results with regard to other specimens and samples.

Date of Test: 2016. 01. 12 ~ 14

Date of Report: 2016. 01. 19

Producer: Sabrina Wang
(Sabrina Wang/Administrator)

Signatory: Ben Cheng
(Ben Cheng/Manager)

1. REPORT HISTORY

Revision	Date	Revision Summary	Report Number
0	2016. 01. 19	Original Report.	EM-F160035

2. SUMMARY OF TEST RESULTS

Rule		Description	Results
FCC	IC		
15.207	RSS-Gen §8.8	Conducted Emission	N/A, Note
15.247(d)/ 15.205	RSS-Gen §8.9 RSS-247 §5.5	Radiated Band Edge and Radiated Spurious Emission	PASS
15.247(a)(1)	RSS-247 §5.1(2)	20dB Bandwidth	PASS
15.247(a)(1)	RSS-247 §5.1(2)	Carrier Frequency Separation	PASS
15.247(a)(1)(iii)	RSS-247 §5.1(4)	Time of Occupancy	PASS
15.247(a)(1)(iii)	RSS-247 §5.1(4)	Number of Hopping Channels	PASS
15.247(b)(1)	RSS-247 §5.1(2)	Maximum Peak Output Power	PASS
15.247(d)	RSS-247 §5.5	Conducted Band Edges and Conducted Spurious Emission	PASS
15.203	---	Antenna Requirement	PASS

Note: The EUT only employs battery power for operation, so it is unnecessary to test.

3. GENERAL INFORMATION

3.1. Description of EUT

Product	Silver box RADIO ASM-RECEIVER
Model Number	LC10S-B
Serial Number	N/A
Brand Name	GM
Applicant	LG Electronics Inc. 222 LG-ro Jinwi-myeon 451-713 Pyeongtaek-si, Gyeonggi-do 451-713, Korea
Manufacture	LG Electronics Inc. 222 LG-ro Jinwi-myeon 451-713 Pyeongtaek-si, Gyeonggi-do 451-713, Korea
Factory	LG ELECTRONICS VIETNAM HAI PHONG CO., LTD. Lots CN2 and CN3, Trang Due Industrial Zone, An Duong District, within Dinh Vu - Cat Hai Economic Zone, Hai Phong City, Vietnam.
RF Features	WLAN:802.11a/b/g/n Bluetooth: BT 3.0+EDR
Transmit Type	1T1R
Date of Receipt of Sample	2016. 01. 06

3.2. EUT Specifications Assessed in Current Report

Mode	Fundamental Range (MHz)	Channel Number	Modulation	Data Rate (Mbps)
Bluetooth	2402-2480	79	FHSS (GFSK, $\pi/4$ DQPSK, 8-DPSK)	1/2/3

Channel List					
Channel Number	Frequency (MHz)	Channel Number	Frequency (MHz)	Channel Number	Frequency (MHz)
00	2402	27	2429	54	2456
01	2403	28	2430	55	2457
02	2404	29	2431	56	2458
03	2405	30	2432	57	2459
04	2406	31	2433	58	2460
05	2407	32	2434	59	2461
06	2408	33	2435	60	2462
07	2409	34	2436	61	2463
08	2410	35	2437	62	2464
09	2411	36	2438	63	2465
10	2412	37	2439	64	2466
11	2413	38	2440	65	2467
12	2414	39	2441	66	2468
13	2415	40	2442	67	2469
14	2416	41	2443	68	2470
15	2417	42	2444	69	2471
16	2418	43	2445	70	2472
17	2419	44	2446	71	2473
18	2420	45	2447	72	2474
19	2421	46	2448	73	2475
20	2422	47	2449	74	2476
21	2423	48	2450	75	2477
22	2424	49	2451	76	2478
23	2425	50	2452	77	2479
24	2426	51	2453	78	2480
25	2427	52	2454		
26	2428	53	2455		

3.3. Antenna Information

Antenna Part Number	Manufacture	Antenna Type	Frequency	Max Gain (dBi)
AMAN1003030LG02	Amotech CO.LTD	Dielectric Chip Antenna	2.4GHz (WLAN & BT)	2.9
			5GHz (WLAN)	UNII Band I: 3.6 UNII Band III: 2.9

3.4. Test Configuration

Item		Modulation	Data Rate	Test Channel
Radiated Test Case	Radiated Band Edge ^{Note1}	8DPSK	3Mbps	00/78
	Radiated Spurious Emission ^{Note1}	8DPSK	3Mbps	00/39/78
Conducted Test Case ^{Note2}	20dB Bandwidth	GFSK	1Mbps	00/39/78
		8-DPSK	3Mbps	00/39/78
	Carrier Frequency Separation	GFSK	1Mbps	00/39/78
		8-DPSK	3Mbps	00/39/78
	Time of Occupancy	GFSK	1Mbps	00/39/78
		8-DPSK	3Mbps	00/39/78
	Number of Hopping Channels	GFSK	1Mbps	39
		8-DPSK	3Mbps	39
	Maximum Peak Output Power	GFSK	1Mbps	00/39/78
		8-DPSK	3Mbps	00/39/78
	Band Edges	GFSK	1Mbps	00/78
		8-DPSK	3Mbps	00/78
	Spurious Emission	GFSK	1Mbps	00/39/78
		8-DPSK	3Mbps	00/39/78

Note 1:

Mobile Device

Portable Device, and 3 axis were assessed. The worst scenario for Radiated Spurious Emission as follow:

- Lie
- Side
- Stand

Note 2: We performed testing of the highest and lowest data rate.

3.5. Tested Supporting System List

3.5.1. Support Peripheral Unit

No.	Product	Brand	Model No.	Serial No.	FCC ID
1.	Display	LG	LC10S	511194947	N/A
2.	DC Power Supply	TOP WARD	3303A	721773	N/A
3.	DC Power Supply	KIKUSUI	PWR400L	N/A	N/A

3.5.2. Cable Lists

No.	Cable Description Of The Above Support Units
1.	Cable: Unshielded, Detachable, 0.6m USB Cable: Unshielded, Detachable, 1.2m
2.	DC Power Cord*2: Unshielded, Detachable, 0.6+0.6m*2
3.	DC Power Cord*2: Unshielded, Detachable, 0.6+0.6m*2

3.6. Setup Configuration

3.6.1. EUT Configuration for Power Line and Radiated Emission



3.6.2. EUT Configuration for Conducted Test Items



3.7. Operating Condition of EUT

EUT was set into test mode and able to be controlled through BT simulator to set channels / hopping / modulations.

3.8. Description of Test Facility

Test Firm Name	:	AUDIX Technology Corporation EMC Department No. 53-11, Dingfu, Linkou Dist., New Taipei City 244, Taiwan
Test Location & Facility	:	Semi-Anechoic Chamber No. 53-11, Dingfu, Linkou Dist., New Taipei City 244, Taiwan IC Test Site Registration No.: 5183B-1 Renewal on September 17, 2014 Fully Anechoic Chamber No. 53-11, Dingfu, Linkou Dist., New Taipei City 244, Taiwan IC Test Site Registration No.: 5183B-4 Renewal on August 31, 2015
NVLAP Lab. Code	:	200077-0
TAF Accreditation No	:	1724

3.9. Measurement Uncertainty

Test Item	Frequency Range	Uncertainty
Radiation Test (Distance: 3m)	30MHz~300MHz	±3.5dB
	300MHz~1000MHz	± 4.70dB
	Above 1GHz	± 1.60dB

Remark : Uncertainty = $ku_c(y)$

Test Item	Uncertainty
20dB Bandwidth	±0.2kHz
Carrier Frequency Separation	±0.2kHz
Time of Occupancy	±0.03sec
Maximum peak Output power	± 0.52dB
Conducted Emission Limitations	± 0.13dB

4. MEASUREMENT EQUIPMENT LIST

4.1. Radiated Emission Measurement

4.1.1. Frequency Range 30MHz~1000MHz (Semi-Anechoic Chamber)

Item	Type	Manufacturer	Model No.	Serial No.	Cal. Date	Cal. Interval
1	Spectrum Analyzer	Agilent	N9010A-526	MY53400071	2015. 09. 14	1 Year
2	Test Receiver	R & S	ESCS30	100338	2015. 06. 24	1 Year
3	Amplifier	HP	8447D	2944A06305	2015. 02. 12	1 Year
4	Bilog Antenna	CHASE	CBL6112D	33821	2015. 02. 27	1 Year
5	Bluetooth Test Set	Anritsu	MT8852B	6K00005697	2015. 03. 18	1 Year

4.1.2. Frequency Range Above 1000MHz (Fully Anechoic Chamber)

Item	Type	Manufacturer	Model No.	Serial No.	Cal. Date	Cal. Interval
1.	Spectrum Analyzer	Agilent	E4446A	US44300366	2015. 08. 20	1 Year
2.	Amplifier	Sonoma	310N	187161	2015. 06. 17	1 Year
3.	Horn Antenna	ETS-Lindgren	3117	00135902	2015. 03. 06	1 Year
4.	2.4GHz Notch Filter	K&L	7NSL10-2441.5 E130.5-00	1	2015. 07. 22	1 Year
5	Bluetooth Test Set	Anritsu	MT8852B	6K00005697	2015. 03. 18	1 Year

4.2. RF Conducted Measurement

Item	Type	Manufacturer	Model No.	Serial No.	Cal. Date	Cal. Interval
1	Spectrum Analyzer	Agilent	N9030A-544	US51350140	2015. 06. 10	1 Year
2	Bluetooth Test Set	Anritsu	MT8852B	6K00005697	2015. 03. 18	1 Year
3	Power Divider	Anritsu	K240C	19728	2015. 02. 09	1 Year

5. RADIATED EMISSION MEASUREMENT

5.1. Block Diagram of Test Setup

5.1.1. Block Diagram of EUT

Indicated as section 3.6

5.1.2. Setup Diagram for 30-1000 MHz

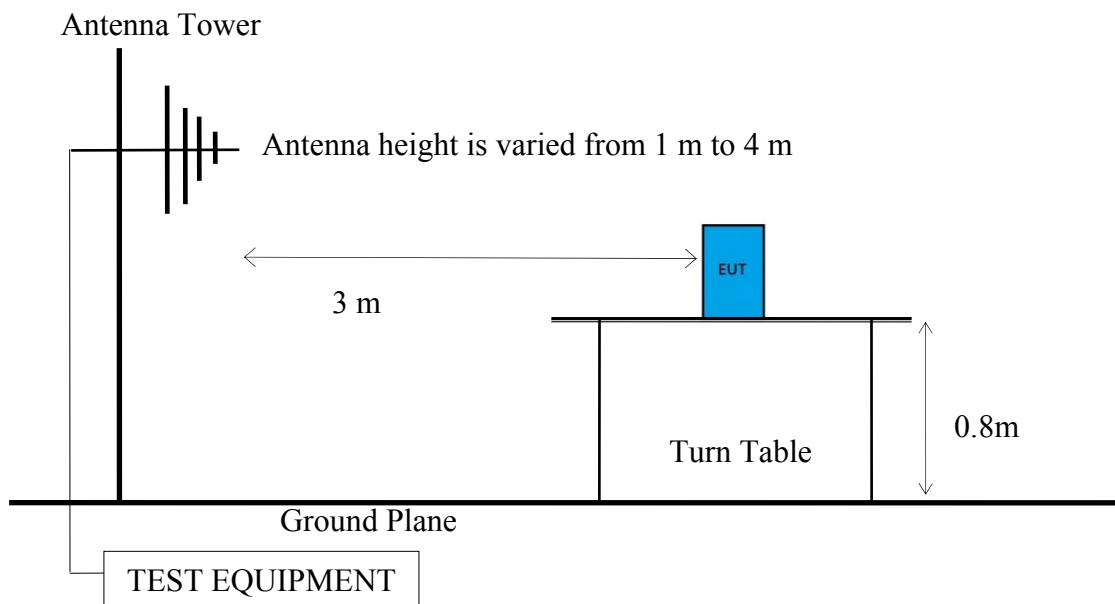

5.1.3. Semi-Anechoic Chamber (3m) Setup Diagram for above 1GHz

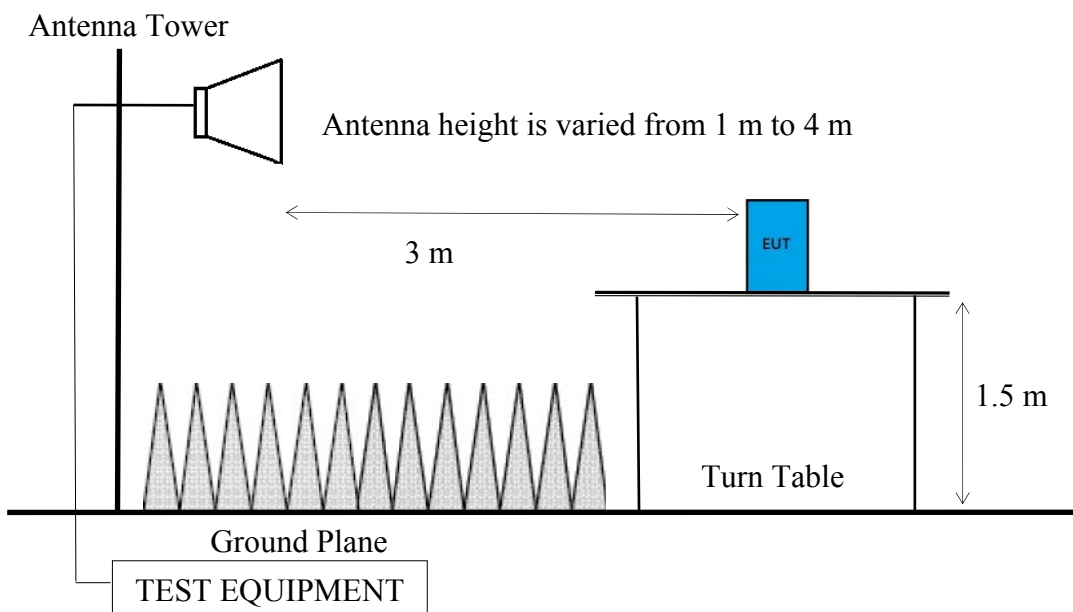

5.2. Radiated Emission Limits

In any 100kHz bandwidth outside the frequency band, the radio frequency power produced by the intentional radiator shall be at least 20dB below that in the 100kHz bandwidth within the band that contains the highest level. In addition, radiated emissions which fall in restricted bands, as defined in Section 15.205, must also comply with the radiated emission limits specified as below.

Frequency (MHz)	Distance (m)	Field Strengths Limits	
		$\mu\text{V/m}$	$\text{dB}\mu\text{V/m}$
30 ~ 88	3	100	40.0
88 ~ 216	3	150	43.5
216 ~ 960	3	200	46.0
Above 960	3	500	54.0
Above 1000	3	74.0 $\text{dB}\mu\text{V/m}$ (Peak) 54.0 $\text{dB}\mu\text{V/m}$ (Average)	

Remark : (1) $\text{dB}\mu\text{V/m} = 20 \log (\mu\text{V/m})$

- (2) The tighter limit applies to the edge between two frequency bands.
- (3) Distance refers to the distance in meters between the measuring instrument antenna and the closed point of any part of the device or system.
- (4) Fundamental and emission fall within operation band are exempted from this section.
- (5) Pursuant to ANSI C63.10: 6.6.4.3, if the maximized peak measured value complies with the average limit, then it is unnecessary to perform an average measurement.

5.3. Test Procedure

The EUT setup on the turn table which has 1.5m height to the ground. The turn table rotated 360 degrees and antenna varied from 1 m to 4 m to find the maximum emission level. Both horizontal and vertical polarization are required. In order to find the maximum emission, all of the interface cables were manipulated according to ANSI C63.10-2013, RSS-Gen and RSS-247 regulation.

Frequency below 1 GHz:

Spectrum Analyzer is used for pre-testing with following setting:

- (1) RBW = 120KHz
- (2) VBW $\geq 3 \times$ RBW.
- (3) Detector = Peak.
- (4) Sweep time = auto.
- (5) Trace mode = max hold.
- (6) Allow sweeps to continue until the trace stabilizes.
- (7) When peak-detected value is lower than limit that the measurement using the Q.P. detector is not required. Otherwise using Q.P. for finally measurement.

Frequency above 1GHz to 10th harmonic:

Peak Detector:

- (1) RBW = 1MHz
- (2) VBW \geq 3 x RBW.
- (3) Detector = Peak.
- (4) Sweep time = auto.
- (5) Trace mode = max hold.
- (6) Allow sweeps to continue until the trace stabilizes.
- (7) When peak-detected value is lower than limit that the measurement using the average detector is not required. Otherwise using average for finally measurement.

Average Measurement:

Option 1:

- (1) RBW = 1 MHz
- (2) VBW = 1/T
- (3) Detector = Peak.
- (4) Sweep time = auto.
- (5) Trace mode = max hold.
- (6) Allow sweeps to continue until the trace stabilizes.

Option 2:

Average Emission Level = Peak Emission Level + D.C.C.F.

5.4. Measurement Result Explanation

Peak Emission Level = Antenna Factor + Cable Loss + Meter Reading

Average Emission Level = Antenna Factor + Cable Loss + Meter Reading

Average Emission Level = Peak Emission Level + DCCF

Duty Cycle Correction Factor (DCCF) = $20\log(TX_{on}/100ms)$ presented in section 3.4

EPR = Peak Emission Level - 95.2dB - 2.14dBi

5.5. Test Results

PASSED.

Test Date	2016/01/14	Temp./Hum.	24°C/41%
Test Voltage	DC 12V		

5.5.1. Emissions within Restricted Frequency Bands

5.5.1.1. Frequency Below 1 GHz

[Note: We performed testing of the highest data rate.]

Modulation	8-DPSK	Frequency	TX 2402MHz
------------	--------	-----------	------------

Antenna at Horizontal Polarization

Emission Frequency (MHz)	Antenna Factor (dB/m)	Cable Loss (dB)	Meter Reading (dBμV)	Emission Level (dBμV/m)	Limits (dBμV/m)	Margin (dB)	Detector
84.32	8.17	3.06	28.08	39.31	40.00	0.69	Peak
191.02	9.20	3.91	24.45	37.56	43.50	5.94	Peak
947.62	20.83	7.82	16.95	45.60	46.00	0.40	Peak

Antenna at Vertical Polarization

Emission Frequency (MHz)	Antenna Factor (dB/m)	Cable Loss (dB)	Meter Reading (dBμV)	Emission Level (dBμV/m)	Limits (dBμV/m)	Margin (dB)	Detector
45.52	10.51	2.59	24.98	38.08	40.00	1.92	Peak
82.38	7.83	3.02	27.92	38.77	40.00	1.23	Peak
611.03	18.38	6.53	13.29	38.20	46.00	7.80	Peak

Modulation	8-DPSK	Frequency	TX 2441MHz
------------	--------	-----------	------------

Antenna at Horizontal Polarization

Emission Frequency (MHz)	Antenna Factor (dB/m)	Cable Loss (dB)	Meter Reading (dBμV)	Emission Level (dBμV/m)	Limits (dBμV/m)	Margin (dB)	Detector
84.32	8.17	3.06	27.51	38.74	40.00	1.26	Peak
179.38	9.14	3.83	25.86	38.83	43.50	4.67	Peak
958.29	20.89	7.88	16.32	45.09	46.00	0.91	Peak

Antenna at Vertical Polarization

Emission Frequency (MHz)	Antenna Factor (dB/m)	Cable Loss (dB)	Meter Reading (dBμV)	Emission Level (dBμV/m)	Limits (dBμV/m)	Margin (dB)	Detector
45.52	10.51	2.59	24.90	38.00	40.00	2.00	Peak
74.62	7.01	2.94	29.05	39.00	40.00	1.00	Peak
675.05	18.64	6.67	11.96	37.27	46.00	8.73	Peak

Modulation	8-DPSK	Frequency	TX 2480MHz
------------	--------	-----------	------------

Antenna at Horizontal Polarization

Emission Frequency (MHz)	Antenna Factor (dB/m)	Cable Loss (dB)	Meter Reading (dB μ V)	Emission Level (dB μ V/m)	Limits (dB μ V/m)	Margin (dB)	Detector
83.35	7.97	3.04	27.55	38.56	40.00	1.44	Peak
190.05	9.19	3.90	25.87	38.96	43.50	4.54	Peak
957.32	20.89	7.88	15.81	44.58	46.00	1.42	Peak

Antenna at Vertical Polarization

Emission Frequency (MHz)	Antenna Factor (dB/m)	Cable Loss (dB)	Meter Reading (dB μ V)	Emission Level (dB μ V/m)	Limits (dB μ V/m)	Margin (dB)	Detector
46.49	10.03	2.60	25.46	38.09	40.00	1.91	Peak
83.35	7.97	3.04	28.03	39.04	40.00	0.96	Peak
604.24	18.34	6.51	13.71	38.56	46.00	7.44	Peak

5.5.1.2. Frequency Above 1 GHz to 10th harmonics

Band Edge:

Modulation	8-DPSK	Frequency	TX 2402MHz
------------	--------	-----------	------------

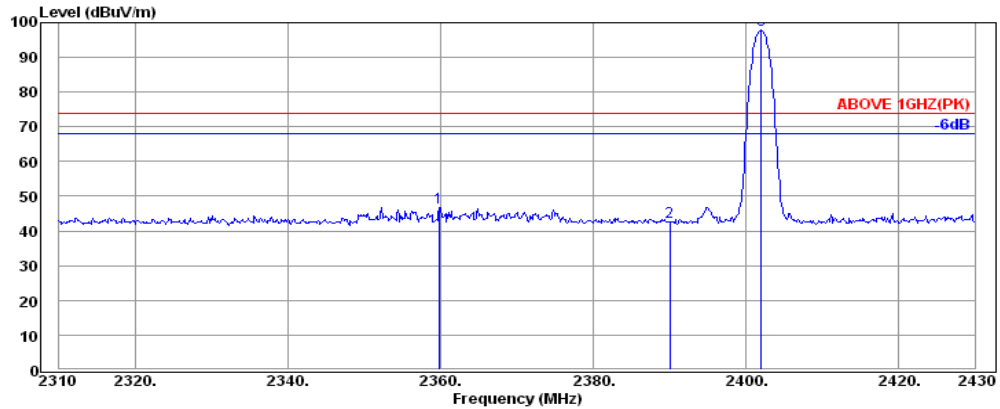

Antenna at Horizontal Polarization

Emission Frequency (MHz)	Antenna Factor (dB/m)	Cable Loss (dB)	Meter Reading (dBμV)	Emission Level (dBμV/m)	Limits (dBμV/m)	Margin (dB)	Detector
2359.80	31.64	6.04	9.16	46.84	74.00	27.16	Peak
2390.04	31.68	6.08	4.77	42.53	74.00	31.47	Peak
2402.04	31.69	6.09	60.25	98.03	---	---	Peak

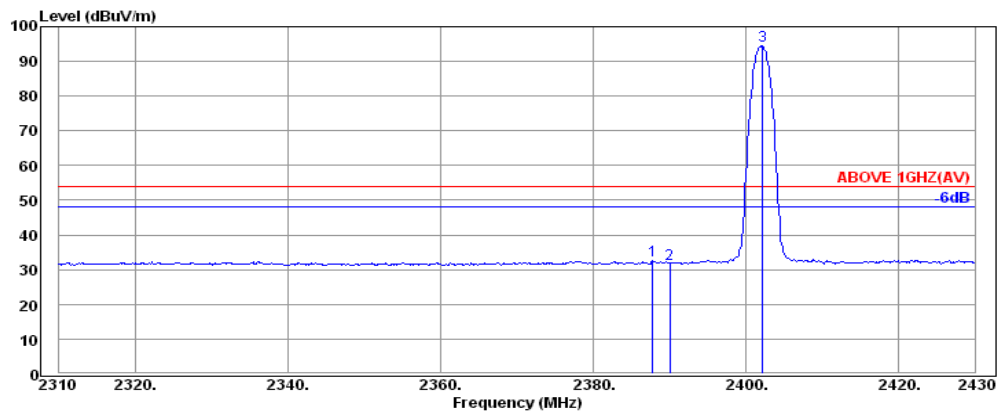

Antenna at Horizontal Polarization

Emission Frequency (MHz)	Antenna Factor (dB/m)	Cable Loss (dB)	Meter Reading (dBμV)	Emission Level (dBμV/m)	Limits (dBμV/m)	Margin (dB)	Detector
2387.76	31.68	6.08	-5.28	32.48	54.00	21.52	Average
2390.04	31.68	6.08	-6.03	31.73	54.00	22.27	Average
2402.16	31.69	6.09	56.62	94.40	---	---	Average

Modulation	8-DPSK	Frequency	TX 2402MHz
------------	--------	-----------	------------

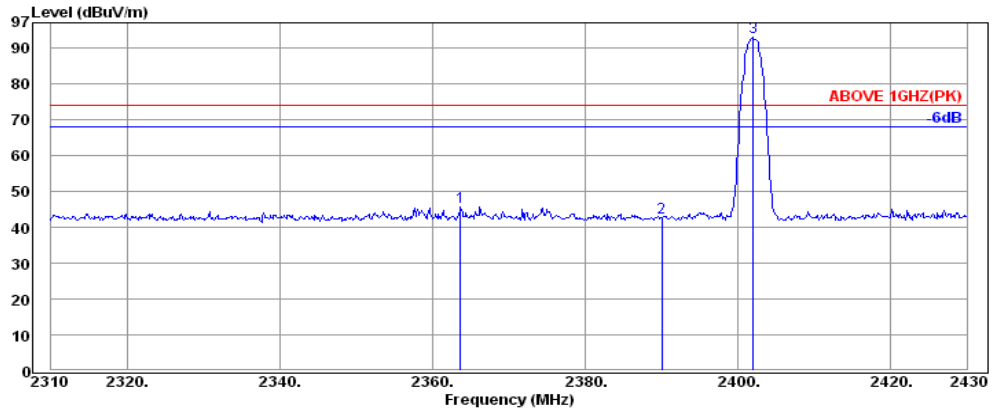

Antenna at Vertical Polarization

Emission Frequency (MHz)	Antenna Factor (dB/m)	Cable Loss (dB)	Meter Reading (dBμV)	Emission Level (dBμV/m)	Limits (dBμV/m)	Margin (dB)	Detector
2363.64	31.65	6.04	8.13	45.82	74.00	28.18	Peak
2390.04	31.68	6.08	5.02	42.78	74.00	31.22	Peak
2402.04	31.69	6.09	55.07	92.85	---	---	Peak

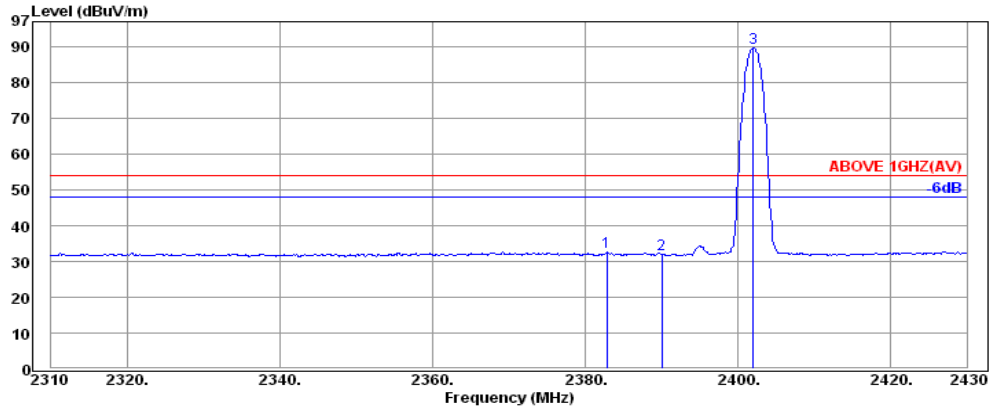

Antenna at Vertical Polarization

Emission Frequency (MHz)	Antenna Factor (dB/m)	Cable Loss (dB)	Meter Reading (dBμV)	Emission Level (dBμV/m)	Limits (dBμV/m)	Margin (dB)	Detector
2382.84	31.67	6.07	-5.15	32.59	54.00	21.41	Average
2390.04	31.68	6.08	-5.86	31.90	54.00	22.10	Average
2402.04	31.69	6.09	51.79	89.57	---	---	Average

Modulation	8-DPSK	Frequency	TX 2480MHz
------------	--------	-----------	------------

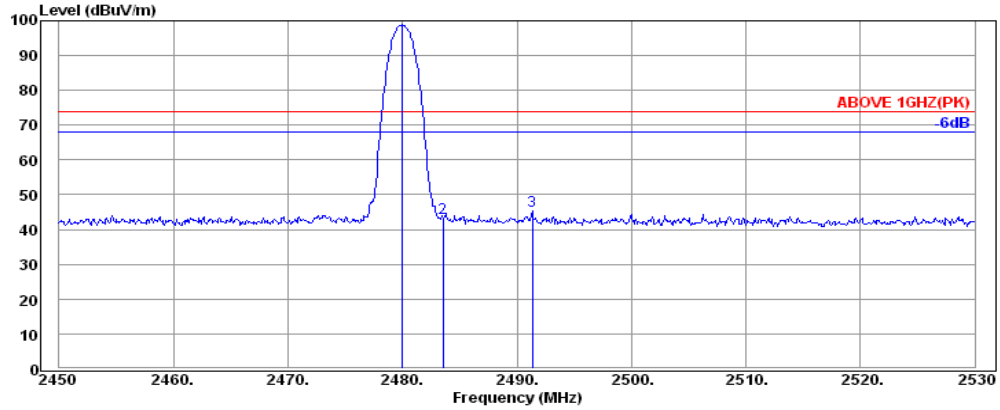

Antenna at Horizontal Polarization

Emission Frequency (MHz)	Antenna Factor (dB/m)	Cable Loss (dB)	Meter Reading (dBμV)	Emission Level (dBμV/m)	Limits (dBμV/m)	Margin (dB)	Detector
2480.00	31.78	6.18	60.93	98.89	---	---	Peak
2483.52	31.78	6.19	5.39	43.36	74.00	30.64	Peak
2491.36	31.79	6.20	7.51	45.50	74.00	28.50	Peak

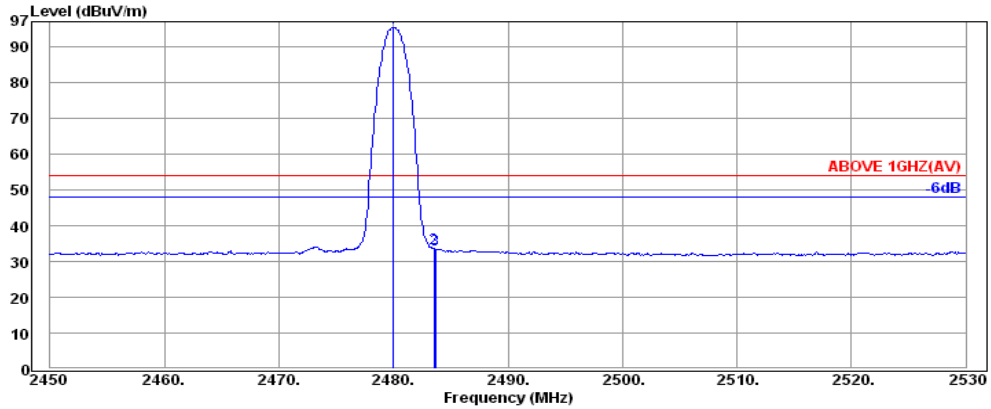

Antenna at Horizontal Polarization

Emission Frequency (MHz)	Antenna Factor (dB/m)	Cable Loss (dB)	Meter Reading (dBμV)	Emission Level (dBμV/m)	Limits (dBμV/m)	Margin (dB)	Detector
2480.00	31.78	6.18	57.38	95.34	---	---	Average
2483.52	31.78	6.19	-4.42	33.55	54.00	20.45	Average
2483.68	31.78	6.19	-4.55	33.42	54.00	20.58	Average

Modulation	8-DPSK	Frequency	TX 2480MHz
------------	--------	-----------	------------

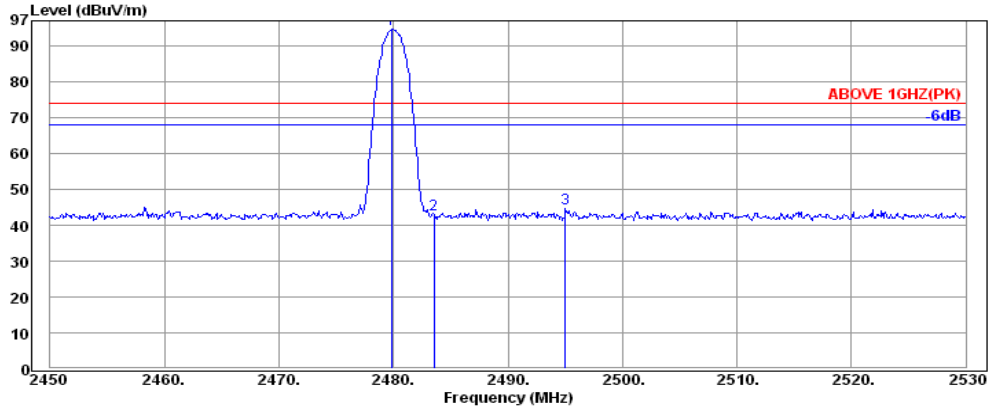

Antenna at Vertical Polarization

Emission Frequency (MHz)	Antenna Factor (dB/m)	Cable Loss (dB)	Meter Reading (dBμV)	Emission Level (dBμV/m)	Limits (dBμV/m)	Margin (dB)	Detector
2479.84	31.78	6.18	56.79	94.75	---	---	Peak
2483.52	31.78	6.19	5.13	43.10	74.00	30.90	Peak
2495.04	31.79	6.20	6.81	44.80	74.00	29.20	Peak

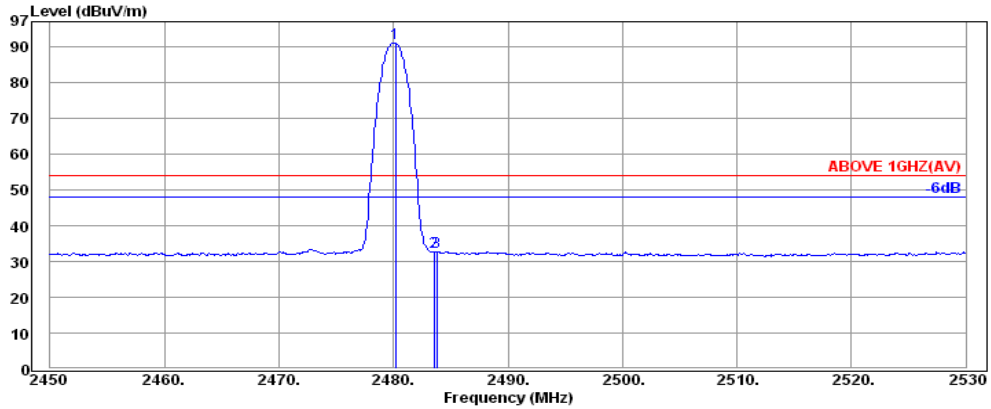

Antenna at Vertical Polarization

Emission Frequency (MHz)	Antenna Factor (dB/m)	Cable Loss (dB)	Meter Reading (dBμV)	Emission Level (dBμV/m)	Limits (dBμV/m)	Margin (dB)	Detector
2480.16	31.78	6.18	53.15	91.11	---	---	Average
2483.52	31.78	6.19	-5.44	32.53	54.00	21.47	Average
2483.76	31.78	6.19	-5.36	32.61	54.00	21.39	Average

5.5.2. Emissions outside the frequency band:

The emissions (up to 25GHz) not reported for there is no emission be found.

Modulation	8-DPSK	Frequency	TX 2402MHz
------------	--------	-----------	------------

Antenna at Horizontal Polarization

Emission Frequency (MHz)	Antenna Factor (dB/m)	Cable Loss (dB)	Meter Reading (dBμV)	Emission Level (dBμV/m)	Limits (dBμV/m)	Margin (dB)	Detector
4792.00	33.82	8.82	2.56	45.20	54.00	8.80	Peak

Modulation	8-DPSK	Frequency	TX 2441MHz
------------	--------	-----------	------------

Antenna at Horizontal Polarization

Emission Frequency (MHz)	Antenna Factor (dB/m)	Cable Loss (dB)	Meter Reading (dBμV)	Emission Level (dBμV/m)	Limits (dBμV/m)	Margin (dB)	Detector
4868.00	33.85	9.09	3.88	46.82	54.00	7.18	Peak

Antenna at Vertical Polarization

Emission Frequency (MHz)	Antenna Factor (dB/m)	Cable Loss (dB)	Meter Reading (dBμV)	Emission Level (dBμV/m)	Limits (dBμV/m)	Margin (dB)	Detector
4868.00	33.85	9.09	2.88	45.82	54.00	8.18	Peak
5528.00	34.47	9.61	0.34	44.42	54.00	9.58	Peak

Modulation	8-DPSK	Frequency	TX 2480MHz
------------	--------	-----------	------------

Antenna at Horizontal Polarization

Emission Frequency (MHz)	Antenna Factor (dB/m)	Cable Loss (dB)	Meter Reading (dB μ V)	Emission Level (dB μ V/m)	Limits (dB μ V/m)	Margin (dB)	Detector
4948.00	33.88	9.35	4.51	47.74	54.00	6.26	Peak
5648.00	34.70	10.02	1.87	46.59	54.00	7.41	Peak

Antenna at Vertical Polarization

Emission Frequency (MHz)	Antenna Factor (dB/m)	Cable Loss (dB)	Meter Reading (dB μ V)	Emission Level (dB μ V/m)	Limits (dB μ V/m)	Margin (dB)	Detector
4948.00	33.88	9.35	5.15	48.38	54.00	5.62	Peak
5648.00	34.70	10.02	2.35	47.07	54.00	6.93	Peak

5.5.3. Emissions in Non-restricted Frequency Bands

All emission levels below the 15.209 general radiated emissions limits is not required.

6. 20dB BANDWIDTH MEASUREMENT

6.1. Block Diagram of Test Setup

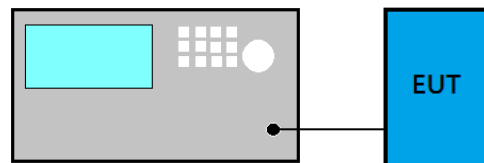

6.2. Specification Limits

Alternatively, frequency hopping systems operating in the 2400-2483.5MHz band may have hopping channel carrier frequencies that are separated by 25kHz or two-thirds of the 20dB bandwidth of the hopping channel, whichever is greater.

6.3. Test Procedure

Following measurement procedure is reference to DA00-705:

- (1) Set RBW close to 1% of OBW.
- (2) Set $VBW \geq RBW$.
- (3) Detector = Peak.
- (4) Trace mode = max hold.
- (5) Sweep = auto couple.
- (6) Allow the trace to stabilize.
- (7) Setting channel bandwidth function x dB to -20 dB to record the final bandwidth.

6.4. Test Results

Please refer to Appendix A

7. CARRIER FREQUENCY SEPARATION MEASUREMENT

7.1. Block Diagram of Test Setup

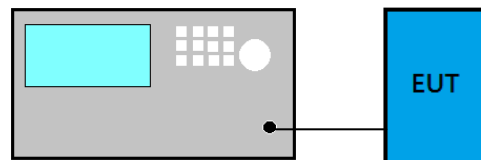

7.2. Specification Limits

Alternatively, frequency hopping systems operating in the 2400-2483.5MHz band may have hopping channel carrier frequencies that are separated by 25kHz or two-thirds of the 20dB bandwidth of the hopping channel, whichever is greater, provided the systems operate with an output no greater than 125mW.

7.3. Test Procedure

Following measurement procedure is reference to DA00-705:

- (1) Span = wide enough to capture the peaks of two adjacent channels
- (2) RBW \geq 1% of the span
- (3) VBW \geq RBW
- (4) Sweep = auto
- (5) Detector function = peak
- (6) Trace = max hold

7.4. Test Results

Please refer to Appendix A

8. TIME OF OCCUPANCY MEASUREMENT

8.1. Block Diagram of Test Setup

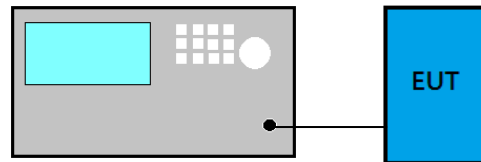

8.2. Specification Limits

Frequency hopping systems in the 2400-2483.5MHz shall use at least 15 non-overlapping channels. The average time of occupancy on any channel shall not be greater than 0.4 seconds within a period of 0.4 seconds multiplied by number of hopping channels employed.

8.3. Test Procedure

Following measurement procedure is reference to DA00-705:

- (1) Span = zero span, centered on a hopping channel
- (2) RBW = 1 MHz
- (3) VBW \geq RBW
- (4) Sweep = as necessary to capture the entire dwell time per hopping channel
- (5) Detector function = peak
- (6) Trace = max hold

8.4. Test Results

Please refer to Appendix A

9. NUMBER OF HOPPING CHANNELS MEASUREMENT

9.1. Block Diagram of Test Setup

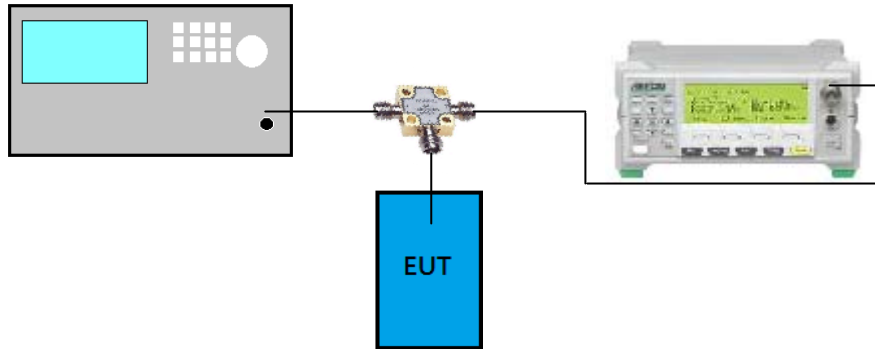

9.2. Specification Limits

Frequency hopping systems which use fewer than 20 hopping frequencies may employ intelligent hopping techniques to avoid interference to other transmissions. Frequency hopping systems may avoid or suppress transmissions on a particular hopping frequency provided that a minimum of 15 non-overlapping channels.

9.3. Test Procedure

Following measurement procedure is reference to DA00-705:

- (1) Span = the frequency band of operation
- (2) RBW \geq 1% of the span
- (3) VBW \geq RBW
- (4) Sweep = auto
- (5) Detector function = peak
- (6) Trace = max hold

9.4. Test Results

Please refer to Appendix A

10. MAXIMUM PEAK OUTPUT POWER MEASUREMENT

10.1. Block Diagram of Test Setup

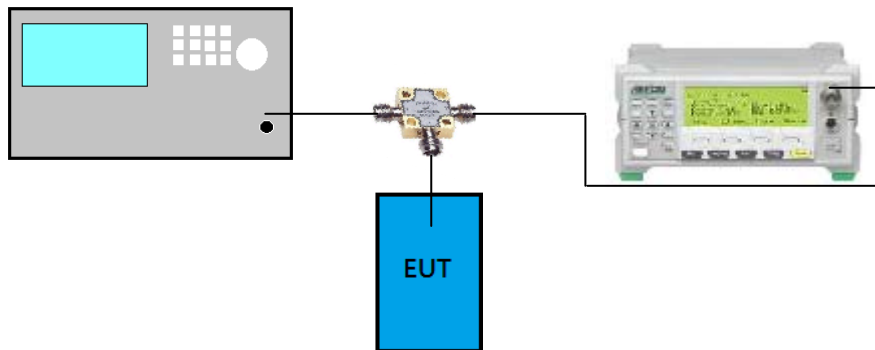

10.2. Specification Limits

The Limits of maximum Peak Output Power for frequency hopping systems in 2400-2483.5MHz is: 0.125Watt. (21dBm)

10.3. Test Procedure

Following measurement procedure is reference to DA00-705:

- (1) Span = approximately 5 times the 20 dB bandwidth, centered on a hopping channel
- (2) RBW \geq 1% of the span
- (3) VBW \geq RBW
- (4) Sweep = auto
- (5) Detector function = peak
- (6) Trace = max hold

10.4. Test Results

Please refer to Appendix A

11. EMISSION LIMITATIONS MEASUREMENT

11.1. Block Diagram of Test Setup

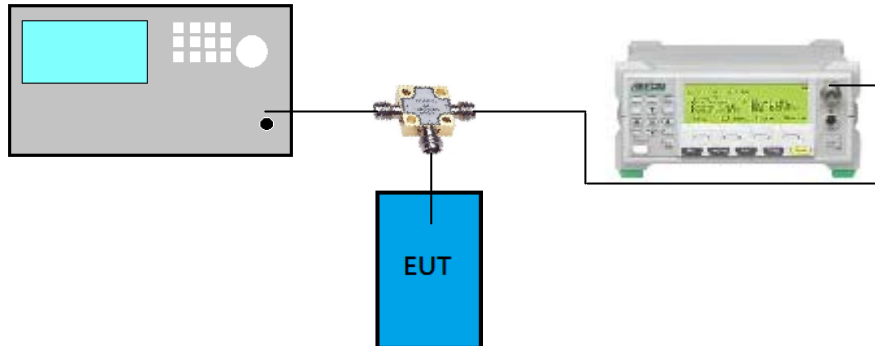

11.2. Specification Limits

In any 100kHz bandwidth outside the frequency band in which the spread spectrum or digitally modulated intentional radiator is operating, the radio frequency power that is produced by the intentional radiator shall be at least 20dB below that in the 100kHz bandwidth within the band that contains the highest level of the desired power, based on either an RF conducted or a radiated measurement. Attenuation below the general limits specified in Section 15.209(a) is not required. In addition, radiated emissions which fall in restricted bands, as defined in Section 15.205(a), must also comply with the radiated emission limits specified in Section 15.209(a) (See Section 15.205(c)).

11.3. Test Procedure

Following measurement procedure is reference to DA00-705:

- (1) Set span wide enough to capture the peak level of the in-band emission and all spurious emissions; up to 10th harmonic.
- (2) RBW = 100 kHz
- (3) VBW \geq RBW
- (4) Sweep = auto
- (5) Detector function = peak
- (6) Trace = max hold

11.4. Test Results

Please refer to Appendix A

12. DEVIATION TO TEST SPECIFICATIONS

【NONE】



AUDIX Technology Corp.
No. 53-11, Dingfu, Linkou, Dist.,
New Taipei City 244, Taiwan

APPENDIX A-Page 1 of 26

Tel: +886 2 26099301

Fax: +886 2 26099303

APPDNDIX A

TEST PLOTS

(Model: LC10S-B)

File Number: C1M1512133

Report Number: EM-F160035

This test report may be reproduced in full only. The document may only be updated by AUDIX Technology Corp. personnel. Any changes will be noted in the Document History section of the report.

TABLE OF CONTENTS

A.1	20dB BANDWIDTH MEASUREMENT	2
A.1.1	20dB Bandwidth Result.....	2
A.1.2	Measurement Plots	3
A.2	CARRIER FREQUENCY SEPARATION MEASUREMENT	4
A.2.1	Measurement Plots	4
A.3	TIME OF OCCUPANCY MEASUREMENT	6
A.3.1	Time of Occupancy.....	6
A.3.2	Measurement Plots	10
A.4	NUMBER OF HOPPING CHANNELS MEASUREMENT	16
A.4.1	Measurement Plots	16
A.5	MAXIMUM PEAK OUTPUT POWER MEASUREMENT	17
A.5.1	Output Power.....	17
A.5.2	Measurement Plots	18
A.6	EMISSION LIMITATIONS MEASUREMENT	19
A.6.1	Band Edge	19
A.6.2	Spurious Emission	21

A.1 20dB BANDWIDTH MEASUREMENT

Test Date	2016/01/12	Temp./Hum.	22°C/60%
Test Voltage	DC 12V		

A.1.1 20dB Bandwidth Result

Modulation	Centre Frequency (MHz)	20 dB Bandwidth (MHz)	2/3 (20dB Bandwidth)
GFSK	2402	0.8756	0.584
	2441	0.8757	0.584
	2480	0.8756	0.584

Modulation	Centre Frequency (MHz)	20 dB Bandwidth (MHz)	2/3 (20dB Bandwidth)
8-DPSK	2402	1.255	0.837
	2441	1.259	0.839
	2480	1.256	0.837

Note: 1. All results have been included cable loss.

2. The maximum two-thirds of the 20dB bandwidth is the limit for carrier frequency separation presented.

A.1.2 Measurement Plots

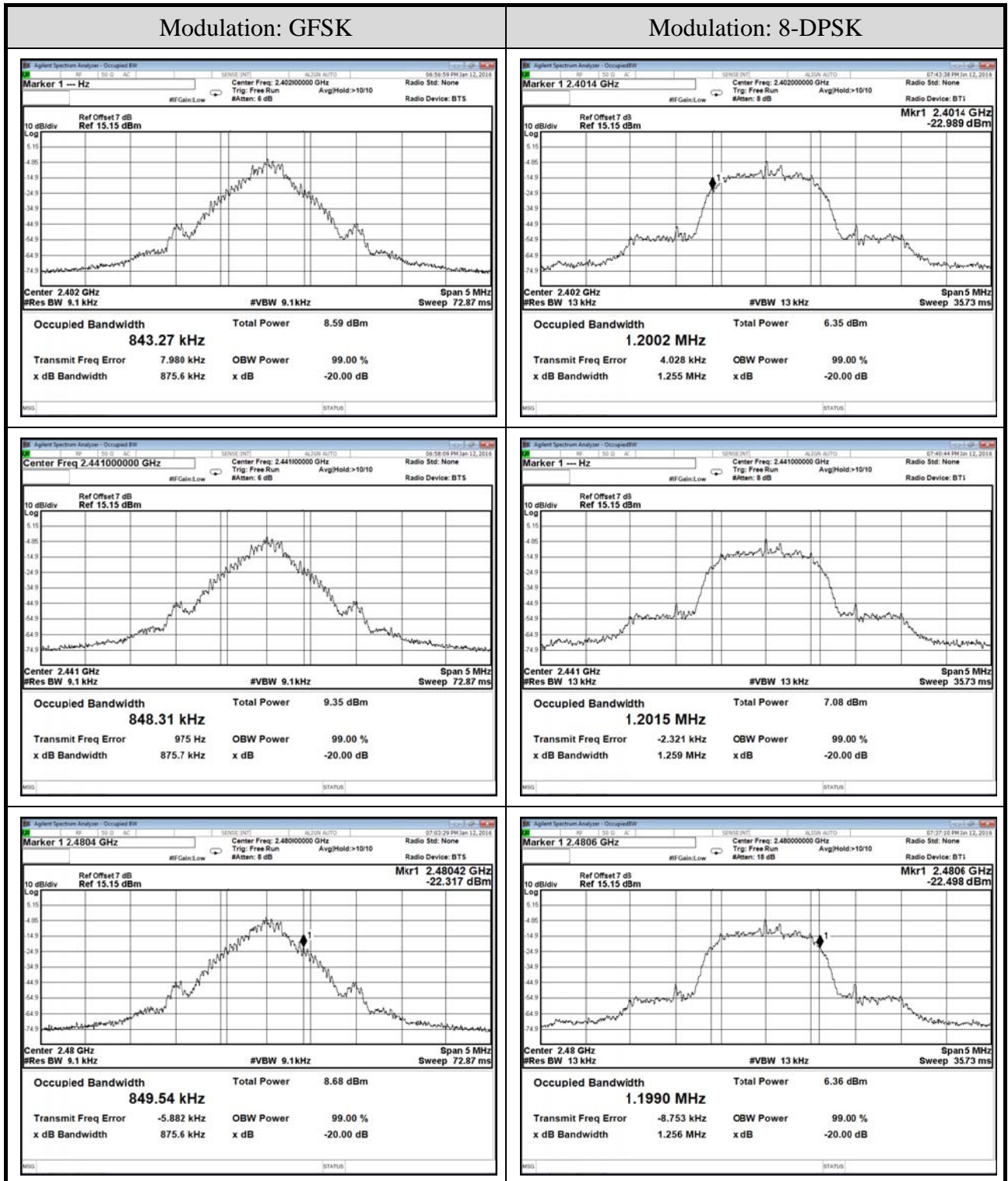

Note: All results have been included cable loss.

A.2 CARRIER FREQUENCY SEPARATION MEASUREMENT

Test Date	2016/01/12	Temp./Hum.	22°C/60%
Test Voltage	DC 12V		

A.2.1 Measurement Plots

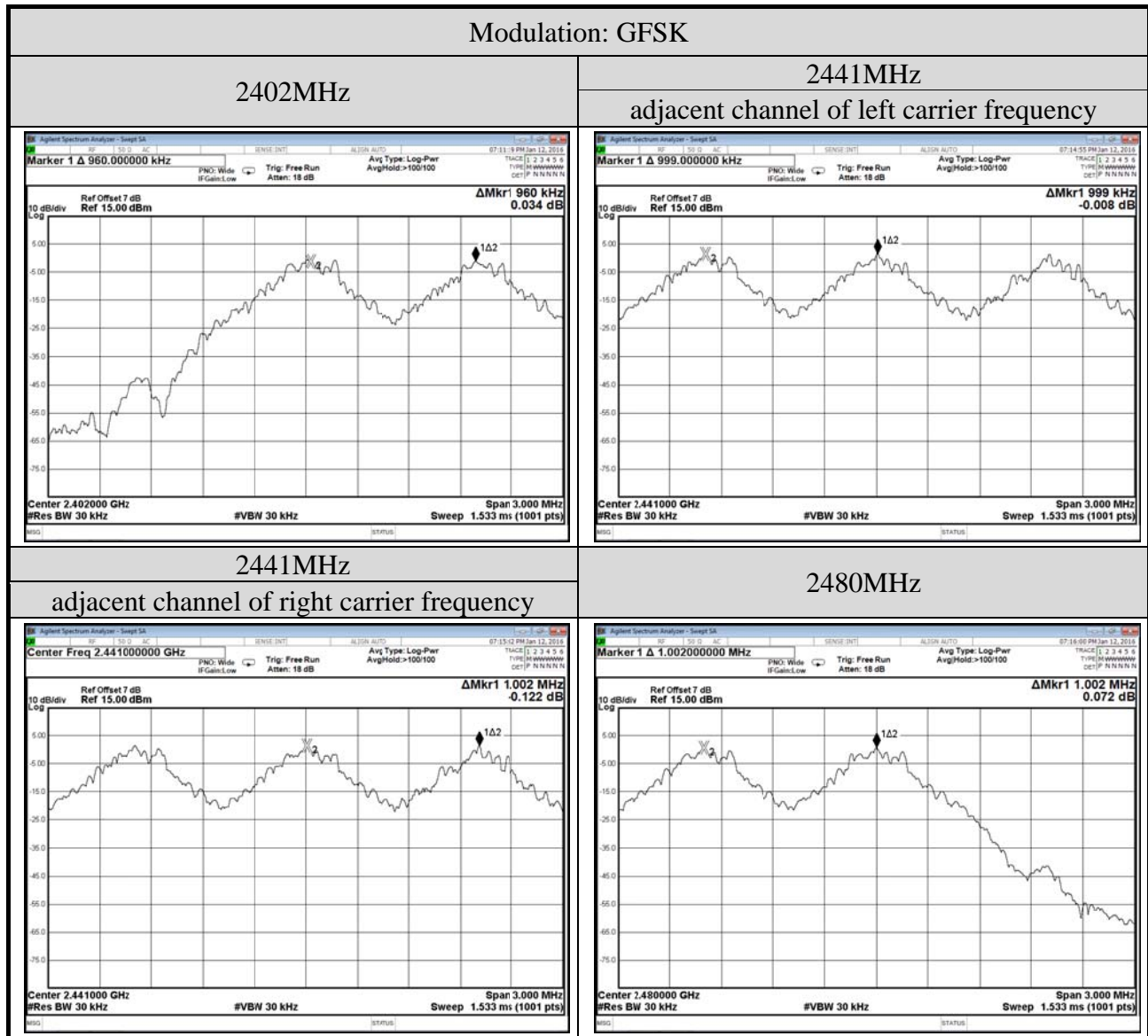

Note: All results have been included cable loss.

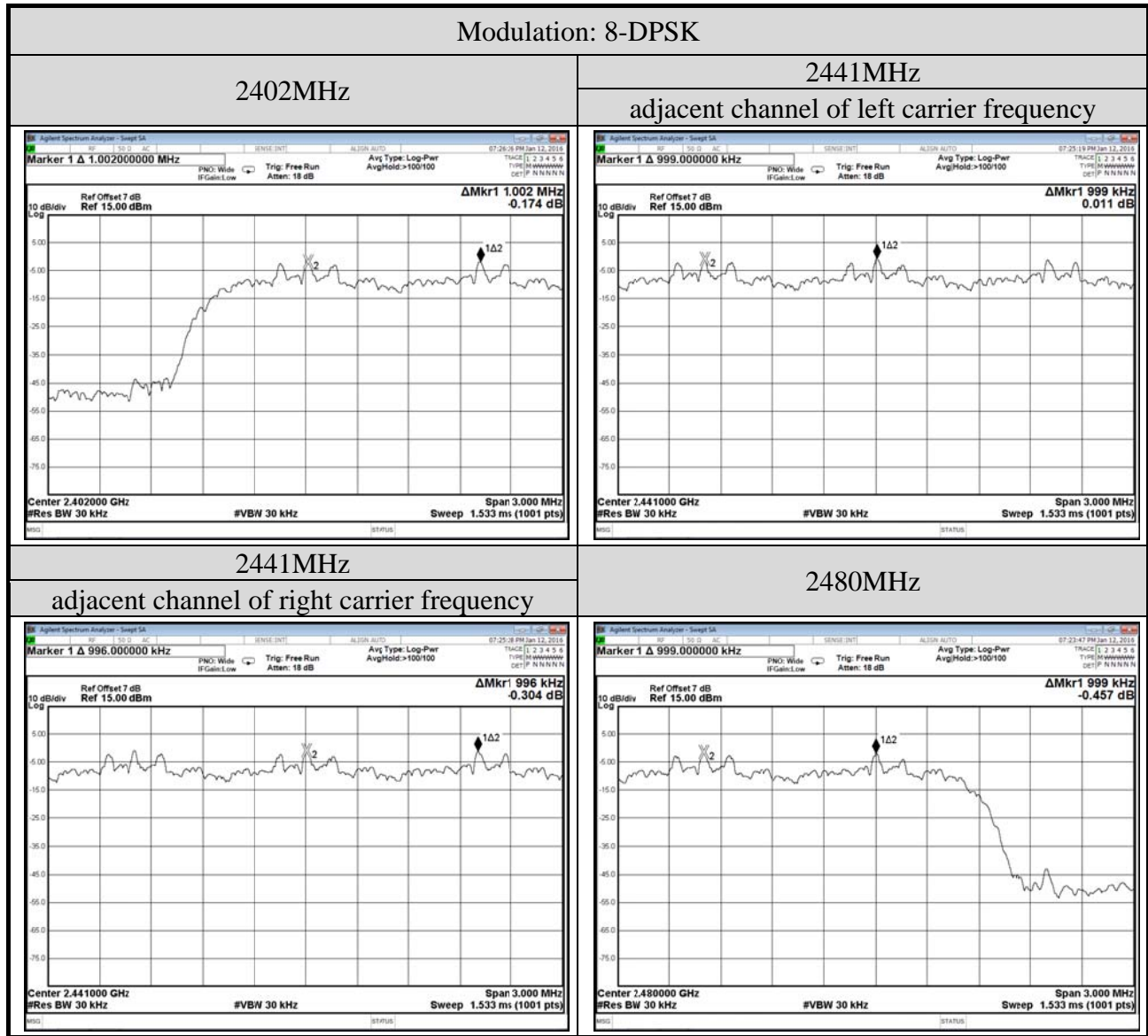

Note: All results have been included cable loss.

A.3 TIME OF OCCUPANCY MEASUREMENT

Test Date	2016/01/12	Temp./Hum.	22°C/60%
Test Voltage	DC 12V		

A.3.1 Time of Occupancy

Modulation	Centre Frequency (MHz)	Mode	Time of Occupancy (ms)	Maximum accumulated Time of Occupancy (ms)	Limit (ms)
GFSK	2402	DH1	0.385	121.660	<400
		DH3	1.640	259.120	<400
		DH5	2.880	364.032	<400
	2441	DH1	0.385	121.660	<400
		DH3	1.630	257.540	<400
		DH5	2.890	365.296	<400
	2480	DH1	0.385	121.660	<400
		DH3	1.640	259.120	<400
		DH5	2.890	365.296	<400

Note: All results have been included cable loss.

Observation Period: 79 channels*0.4 seconds = 31.6 seconds

Centre Frequency: 2402MHz

DH1: For each 1 second of 10 channel appearance, the longest time of occupancy for each of 31.6 seconds is:

10 channels*31.6 seconds* **0.385** ms= **121.660** ms

DH3: For each 5 second of 5 channel appearance, the longest time of occupancy for each of 31.6 seconds is:

5 channels*31.6 seconds* **1.640** ms= **259.120** ms

DH5: For each 5 second of 4 channel appearance, the longest time of occupancy for each of 31.6 seconds is:

4 channels*31.6 seconds* **2.880** ms= **364.032** ms

Centre Frequency: 2441MHz

DH1: For each 1 second of 10 channel appearance, the longest time of occupancy for each of 31.6 seconds is:

10 channels*31.6 seconds* **0.385** ms= **121.660** ms

DH3: For each 5 second of 5 channel appearance, the longest time of occupancy for each of 31.6 seconds is:

5 channels*31.6 seconds* **1.630** ms= **257.540** ms

DH5: For each 5 second of 4 channel appearance, the longest time of occupancy for each of 31.6 seconds is:

4 channels*31.6 seconds* **2.890** ms= **365.296** ms

Centre Frequency: 2480MHz

DH1: For each 1 second of 10 channel appearance, the longest time of occupancy for each of 31.6 seconds is:

10 channels*31.6 seconds* **0.385** ms= **121.660** ms

DH3: For each 5 second of 5 channel appearance, the longest time of occupancy for each of 31.6 seconds is:

5 channels*31.6 seconds* **1.640** ms= **259.120** ms

DH5: For each 5 second of 4 channel appearance, the longest time of occupancy for each of 31.6 seconds is:

4 channels*31.6 seconds* **2.890** ms= **365.296** ms

Modulation	Centre Frequency (MHz)	Mode	Time of Occupancy (ms)	Maximum accumulated Time of Occupancy (ms)	Limit (ms)
8-DPSK	2402	3DH1	0.390	123.240	<400
		3DH3	1.640	259.120	<400
		3DH5	2.890	365.296	<400
	2441	3DH1	0.390	123.240	<400
		3DH3	1.640	259.120	<400
		3DH5	2.880	364.032	<400
	2480	3DH1	0.390	123.240	<400
		3DH3	1.630	257.540	<400
		3DH5	2.890	365.296	<400

Note: All results have been included cable loss.

Observation Period: 79 channels*0.4 seconds = 31.6 seconds

Centre Frequency: 2402MHz

3DH1: For each 1 second of 10 channel appearance, the longest time of occupancy for each of 31.6 seconds is:

10 channels*31.6 seconds* **0.390** ms= **123.240** ms

3DH3: For each 5 second of 5 channel appearance, the longest time of occupancy for each of 31.6 seconds is:

5 channels*31.6 seconds* **1.640** ms= **259.120** ms

3DH5: For each 5 second of 4 channel appearance, the longest time of occupancy for each of 31.6 seconds is:

4 channels*31.6 seconds* **2.890** ms= **365.296** ms

Centre Frequency: 2441MHz

3DH1: For each 1 second of 10 channel appearance, the longest time of occupancy for each of 31.6 seconds is:

10 channels*31.6 seconds* **0.390** ms= **123.240** ms

3DH3: For each 5 second of 5 channel appearance, the longest time of occupancy for each of 31.6 seconds is:

5 channels*31.6 seconds* **1.640** ms= **259.120** ms

3DH5: For each 5 second of 4 channel appearance, the longest time of occupancy for each of 31.6 seconds is:

4 channels*31.6 seconds* **2.880** ms= **364.032** ms

Centre Frequency: 2480MHz

3DH1: For each 1 second of 10 channel appearance, the longest time of occupancy for each of 31.6 seconds is:

10 channels*31.6 seconds* **0.390** ms= **123.240** ms

3DH3: For each 5 second of 5 channel appearance, the longest time of occupancy for each of 31.6 seconds is:

5 channels*31.6 seconds* **1.630** ms= **257.540** ms

3DH5: For each 5 second of 4 channel appearance, the longest time of occupancy for each of 31.6 seconds is:

4 channels*31.6 seconds* **2.890** ms= **365.296** ms

A.3.2 Measurement Plots

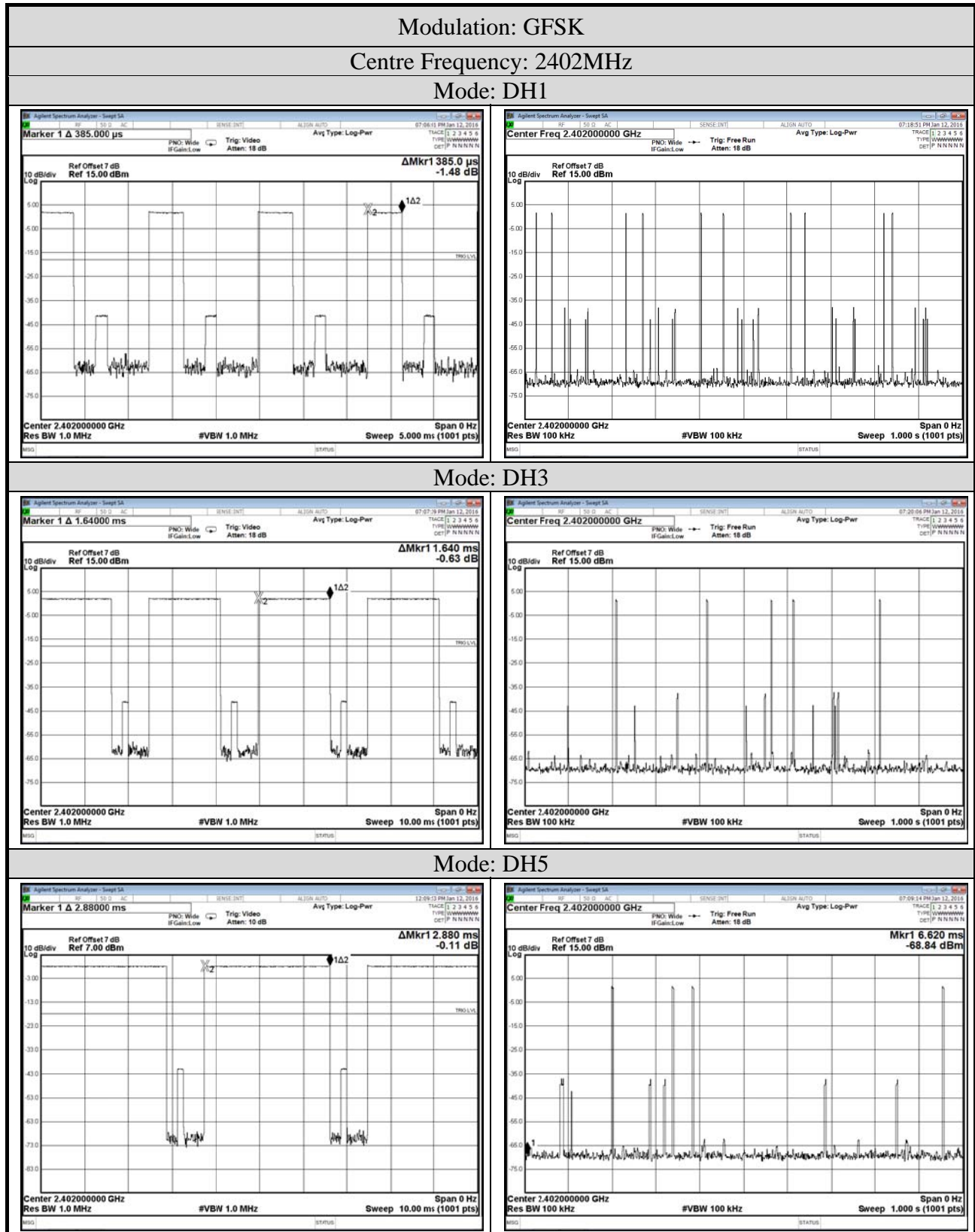

Note: All results have been included cable loss.

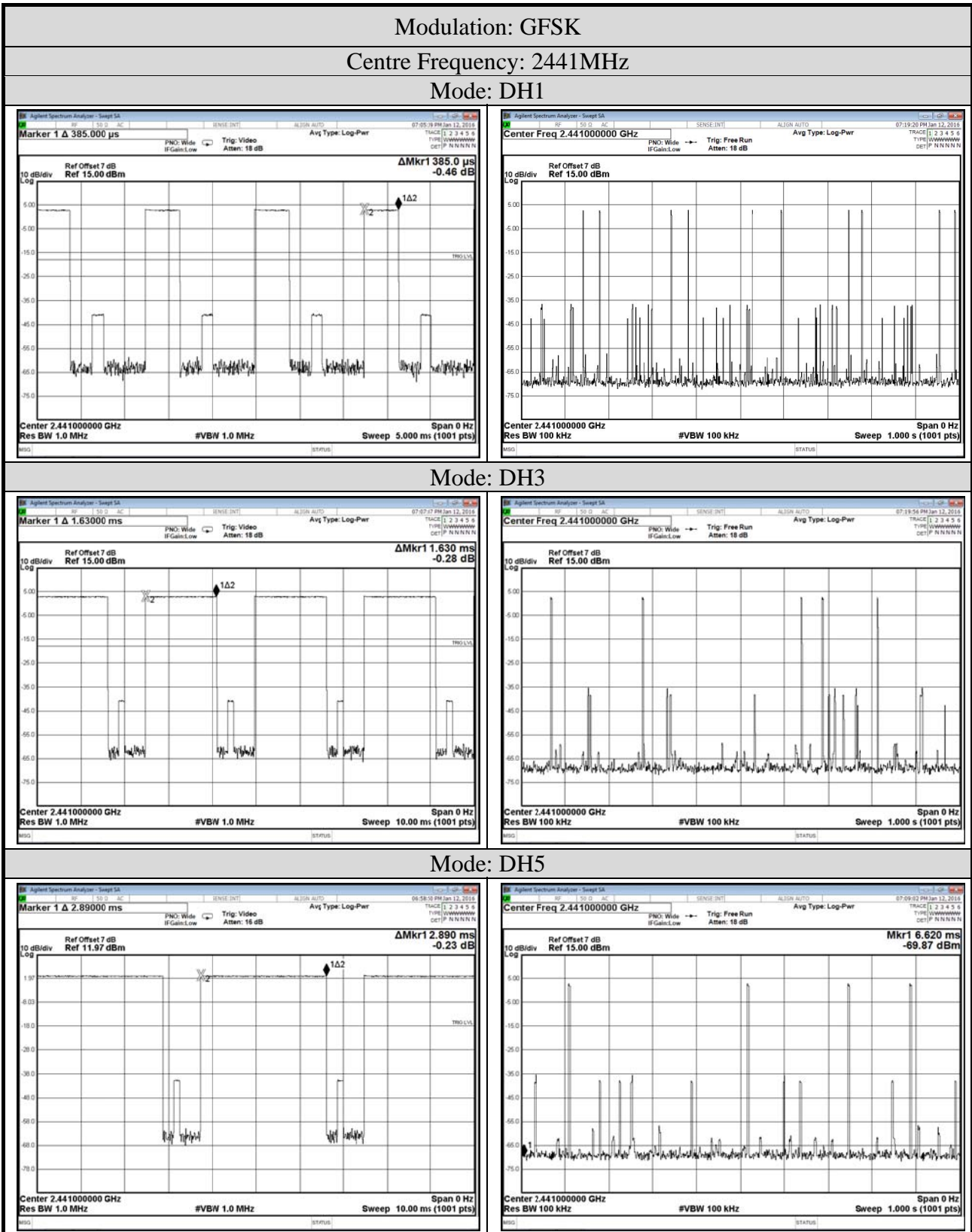

Note: All results have been included cable loss.

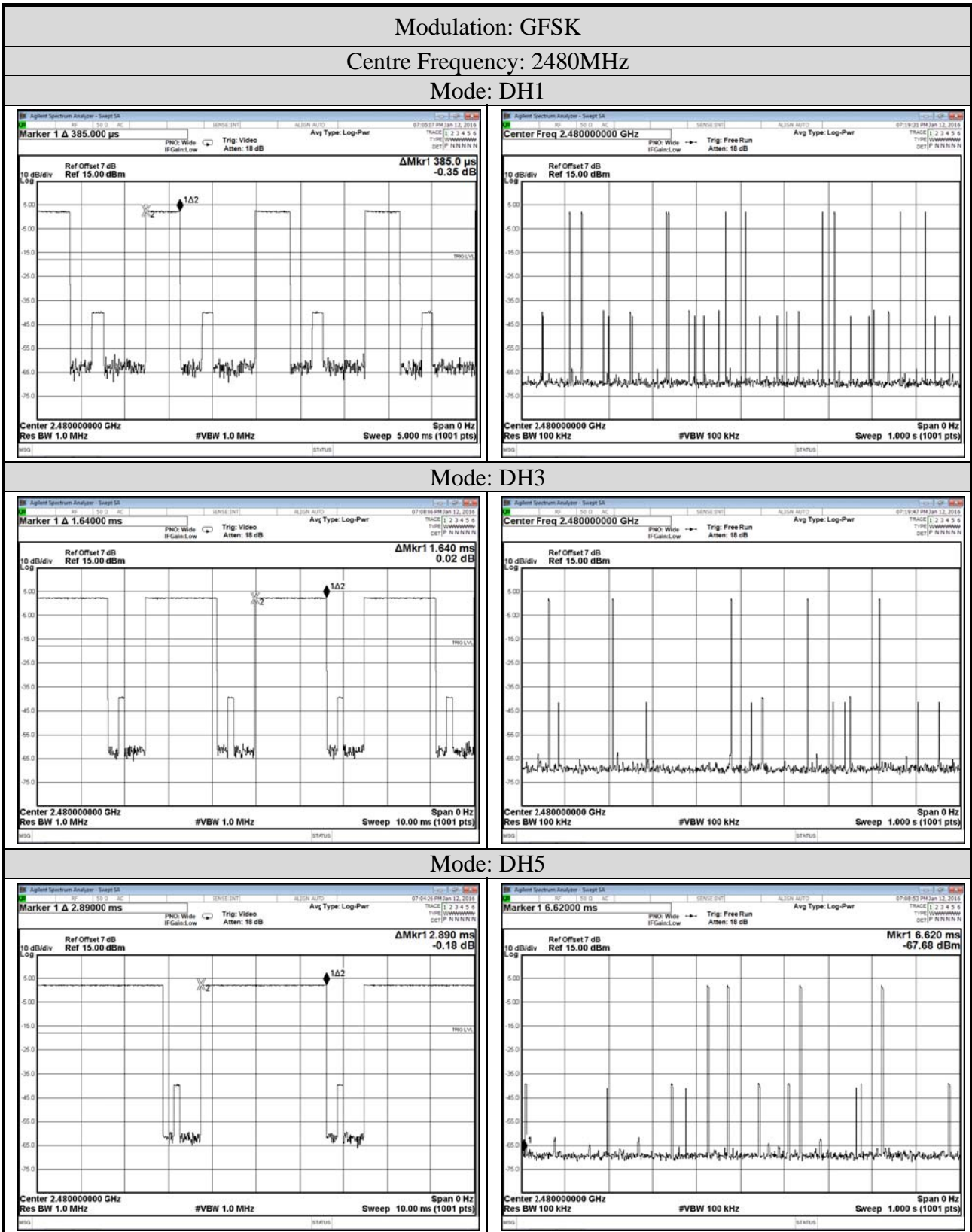

Note: All results have been included cable loss.



Note: All results have been included cable loss.

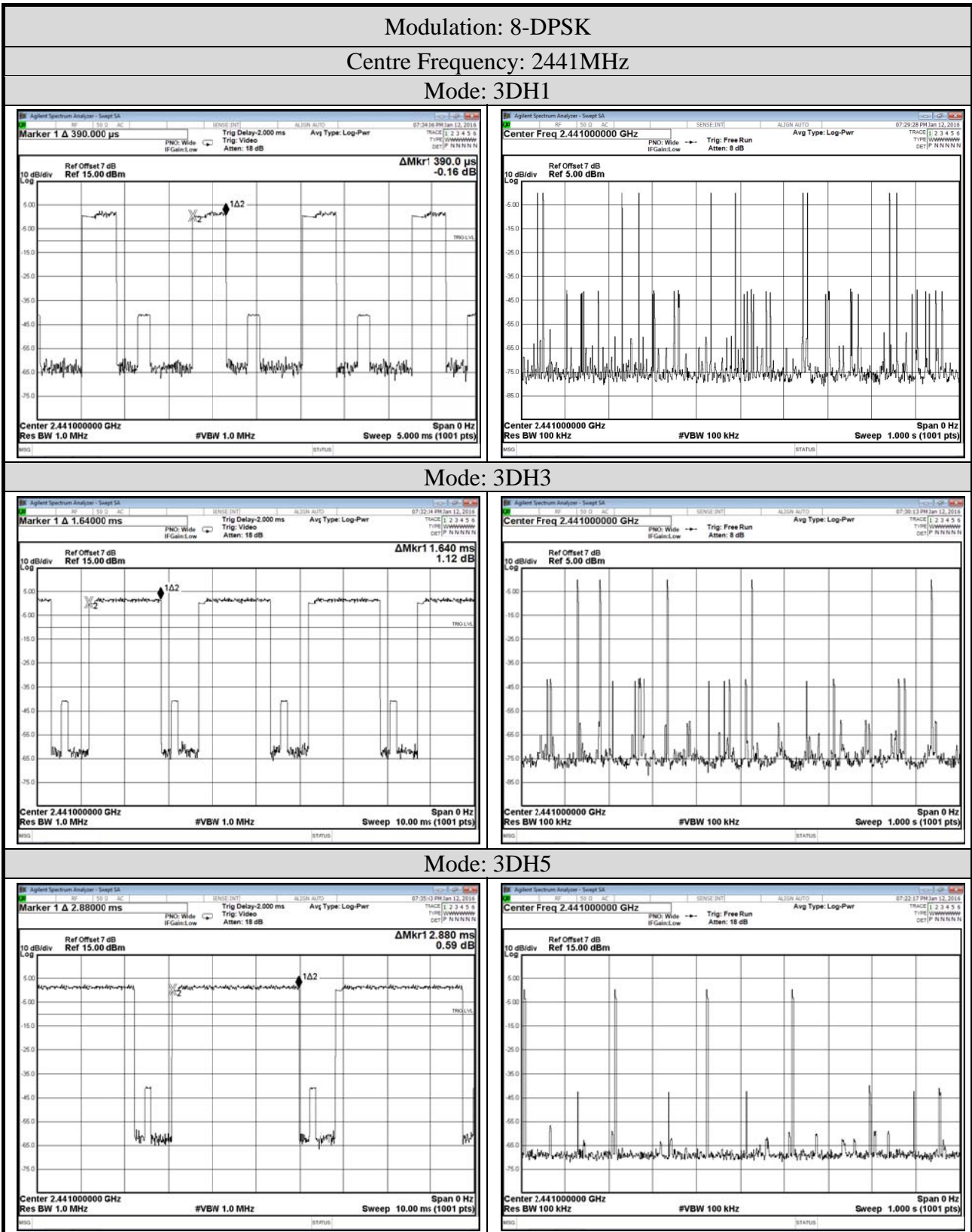

Note: All results have been included cable loss.

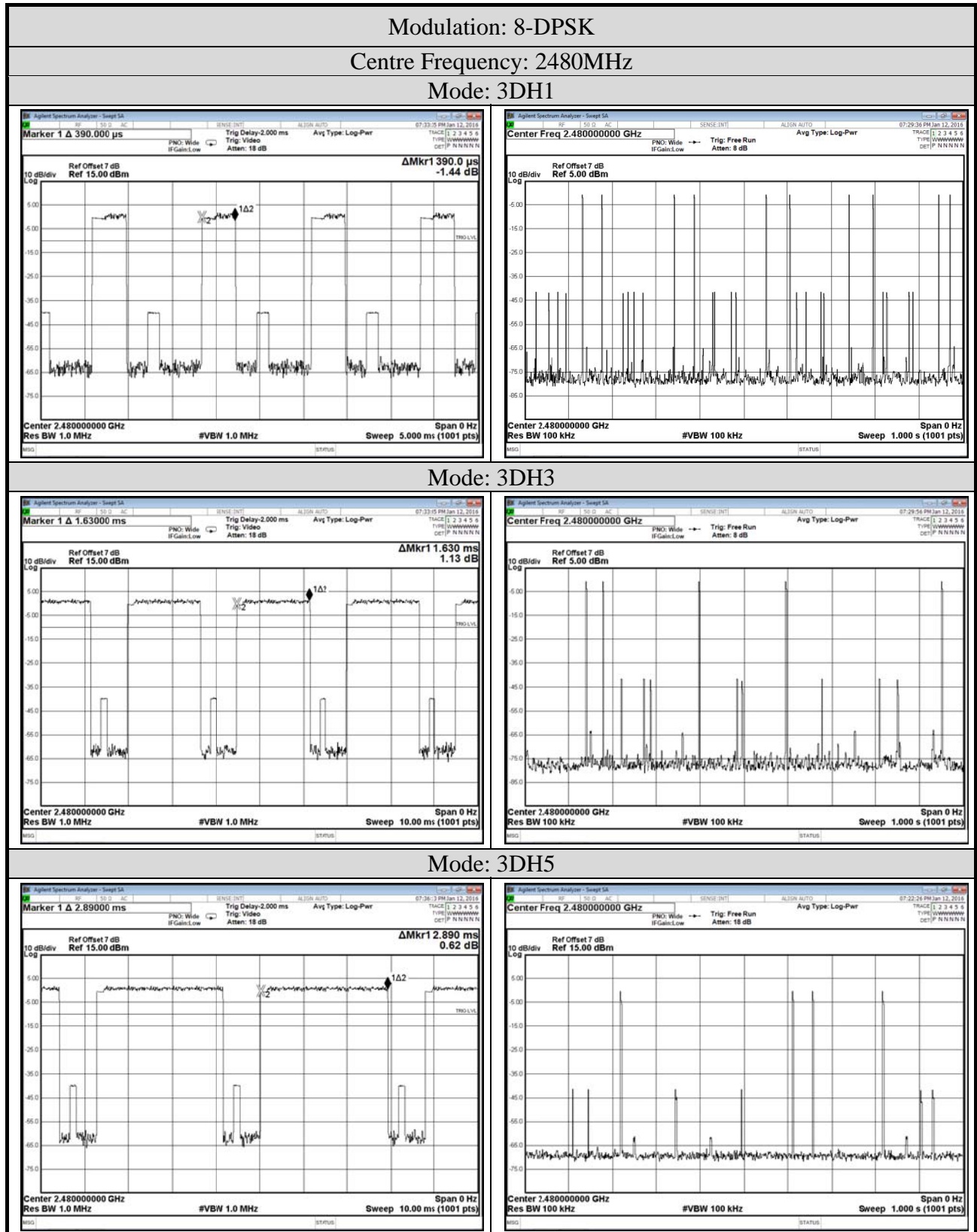

Note: All results have been included cable loss.

A.4 NUMBER OF HOPPING CHANNELS MEASUREMENT

Test Date	2016/01/12	Temp./Hum.	22°C/60%
Test Voltage	DC 12V		

A.4.1 Measurement Plots

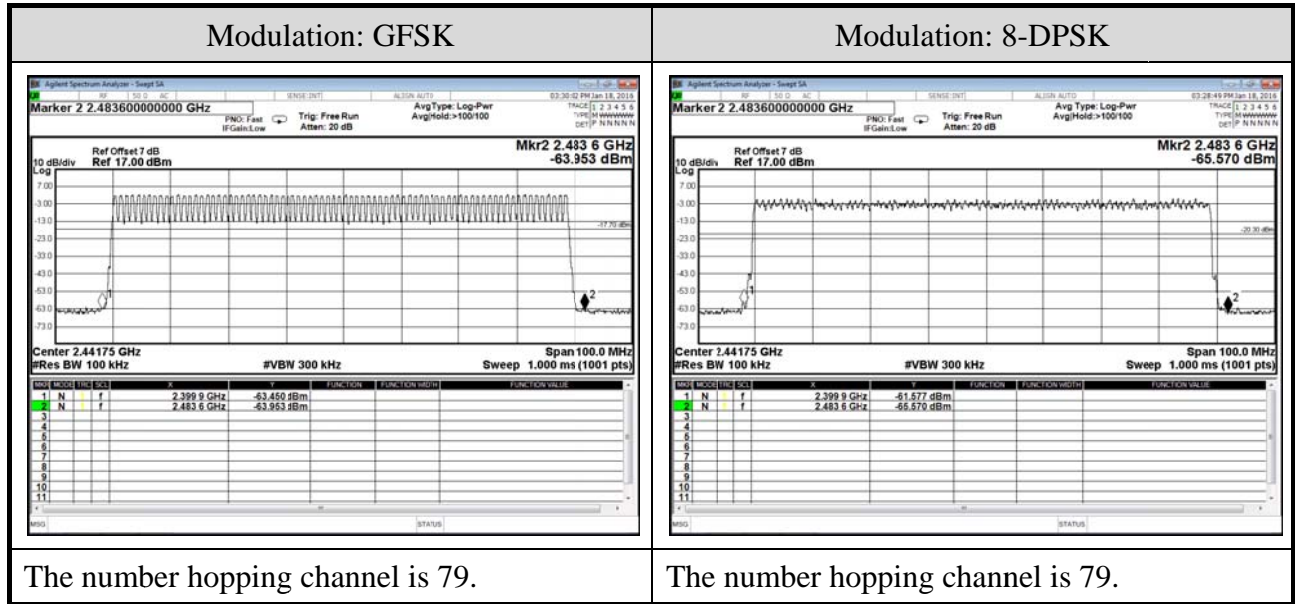

Note: All results have been included cable loss.

A.5 MAXIMUM PEAK OUTPUT POWER MEASUREMENT

Test Date	2016/01/12	Temp./Hum.	22°C/60%
Test Voltage	DC 12V		

A.5.1 Output Power

Modulation	Centre Frequency (MHz)	Peak Output Power		Limit
		dBm	W	
GFSK	2402	2.310	0.001702	21dBm (0.125W)
	2441	3.211	0.002095	
	2480	3.024	0.002006	

Modulation	Centre Frequency (MHz)	Peak Output Power		Limit
		dBm	W	
8-DPSK	2402	2.948	0.001972	21dBm (0.125W)
	2441	3.997	0.002510	
	2480	2.912	0.001955	

Note: All results have been included cable loss.

A.5.2 Measurement Plots

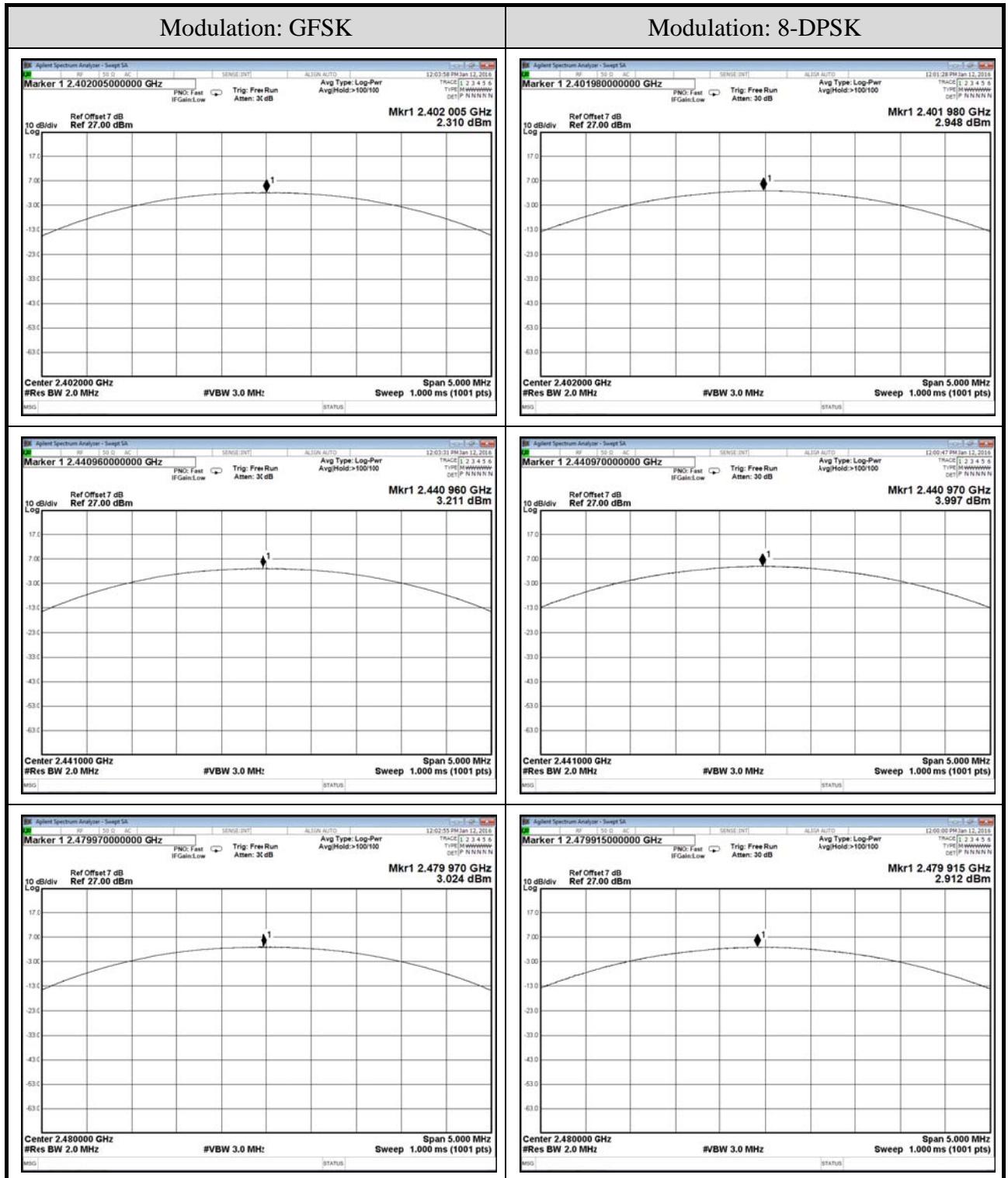

Note: All results have been included cable loss.

A.6 EMISSION LIMITATIONS MEASUREMENT

A.6.1 Band Edge

Test Date	2016/01/12	Temp./Hum.	22°C/60%
Test Voltage	DC 12V		

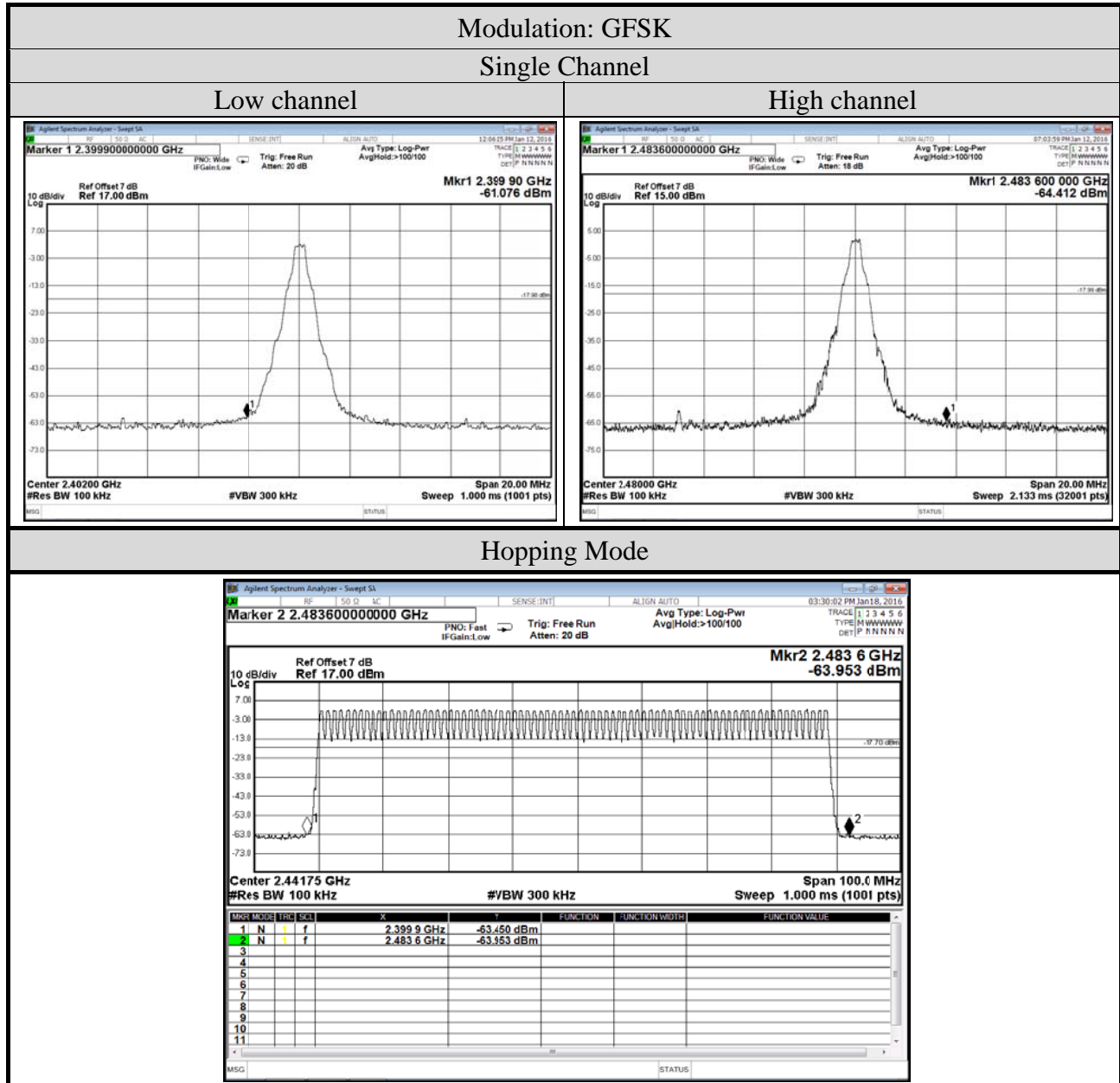

Note: All results have been included cable loss.

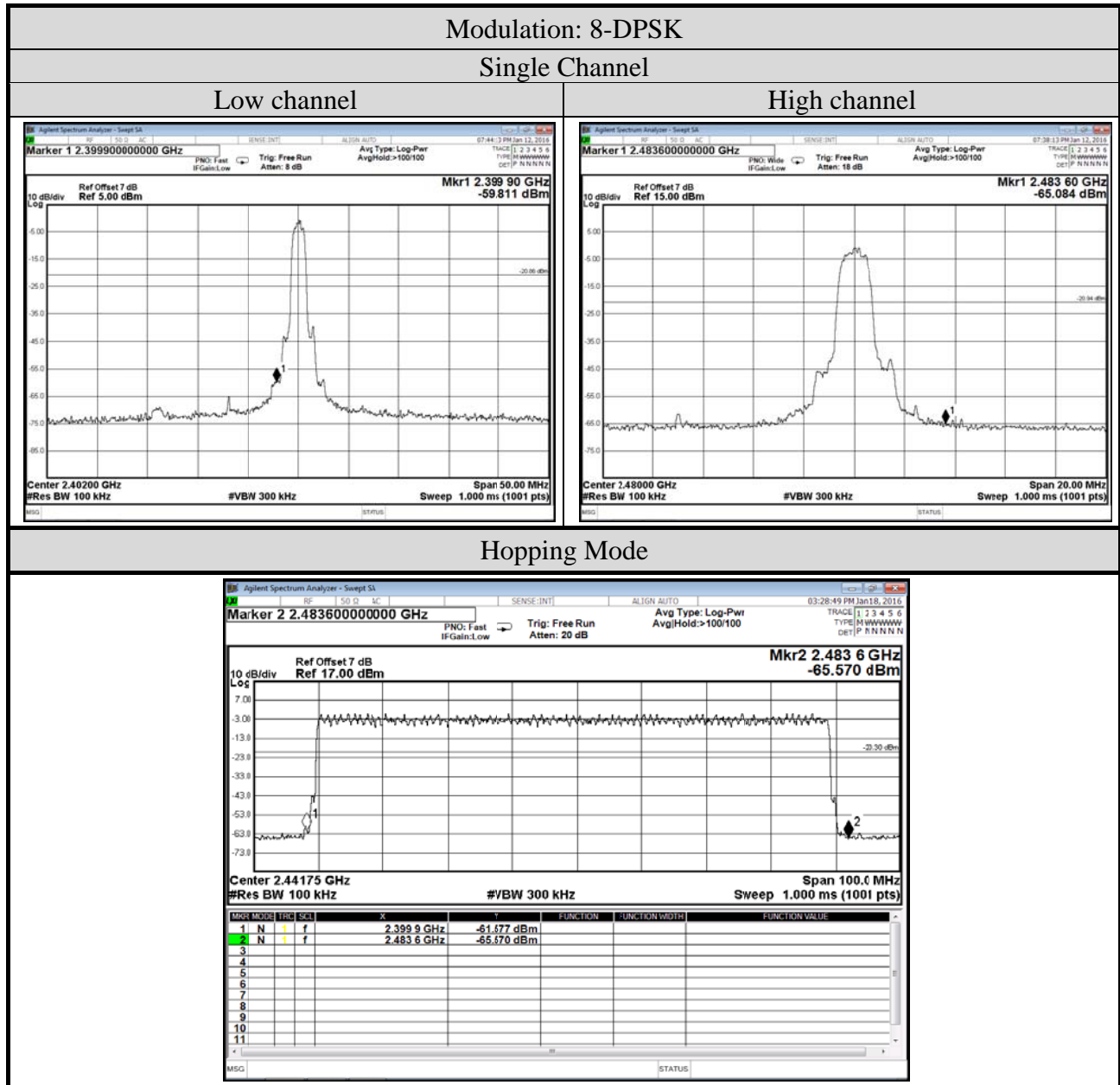

Note: All results have been included cable loss.

A.6.2 Spurious Emission

Test Date	2016/01/12	Temp./Hum.	22°C/60%
Modulation	GFSK	Frequency	2402MHz
Test Voltage	DC 12V		

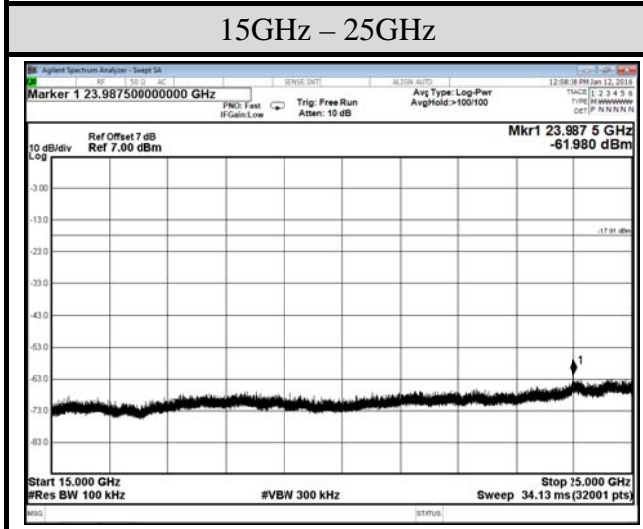
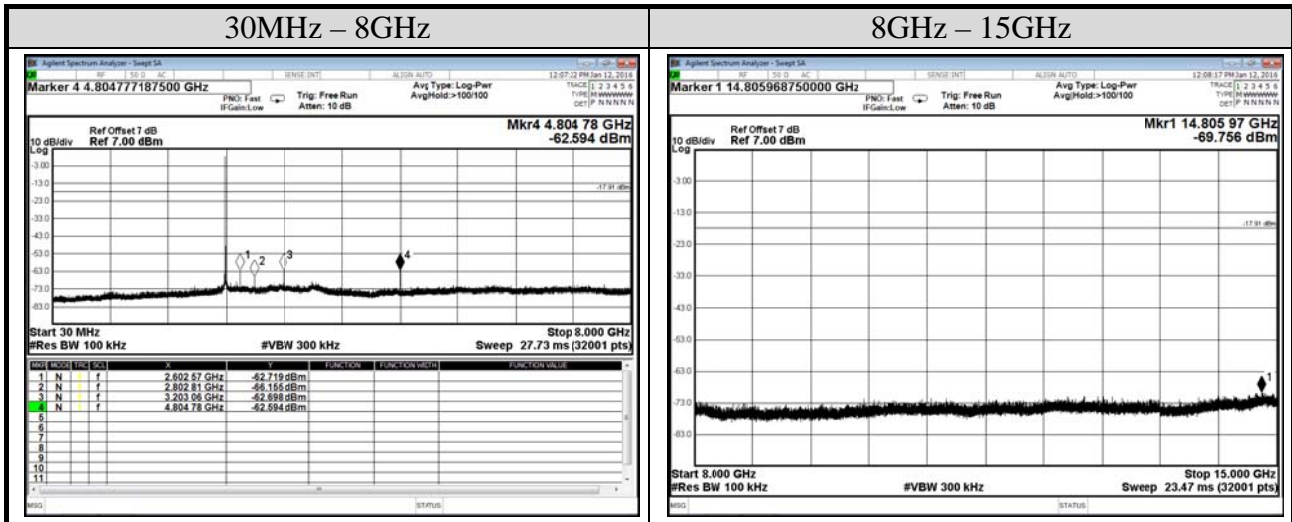

Note: All results have been included cable loss.

Test Date	2016/01/12	Temp./Hum.	22°C/60%
Modulation	GFSK	Frequency	2441MHz
Test Voltage	DC 12V		

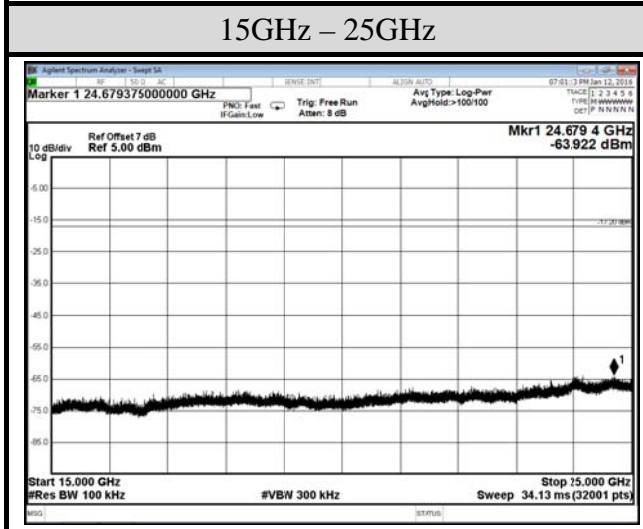
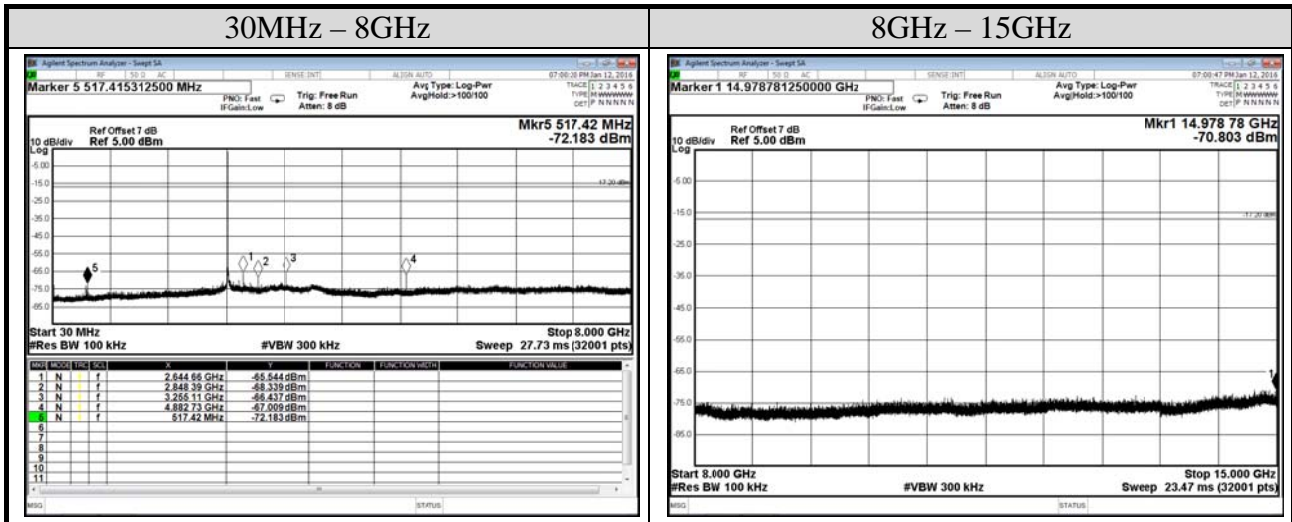

Note: All results have been included cable loss.

Test Date	2016/01/12	Temp./Hum.	22°C/60%
Modulation	GFSK	Frequency	2480MHz
Test Voltage	DC 12V		

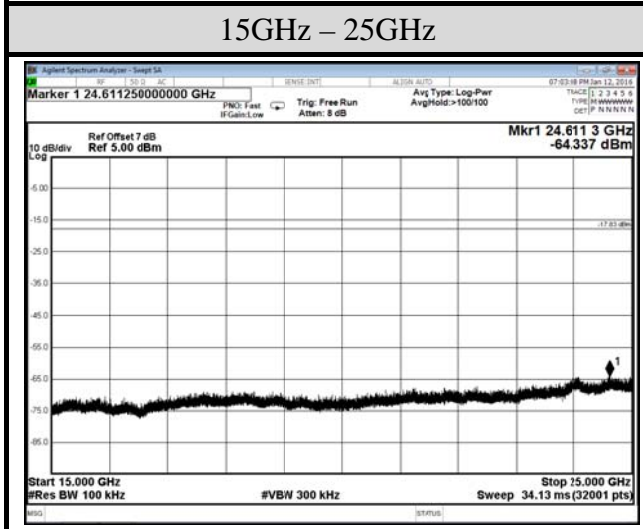
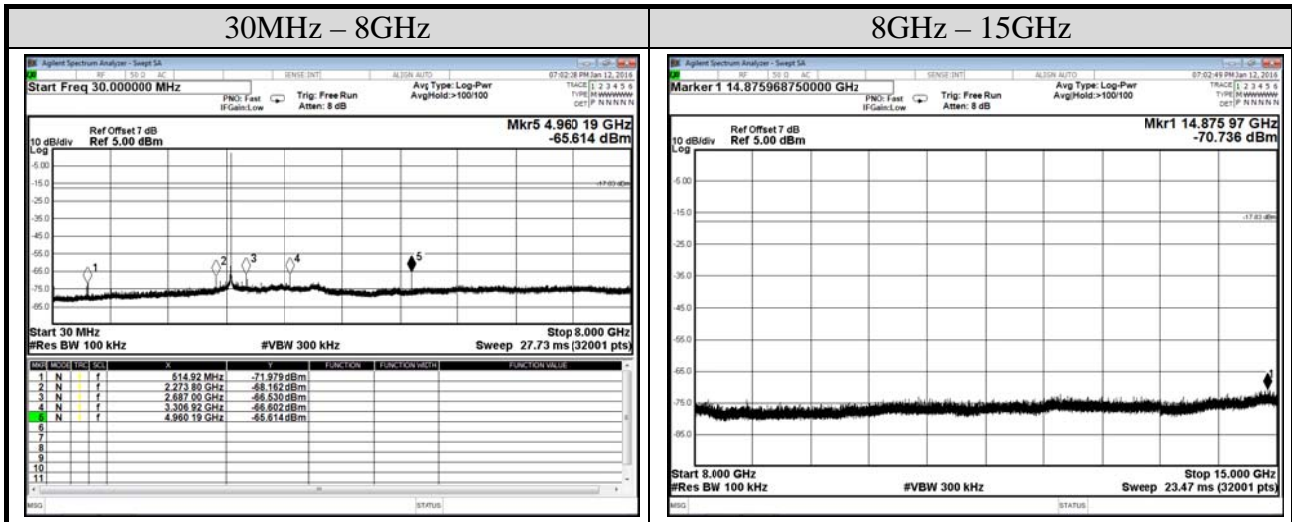

Note: All results have been included cable loss.

Test Date	2016/01/12	Temp./Hum.	22°C/60%
Modulation	8-DPSK	Frequency	2402MHz
Test Voltage	DC 12V		

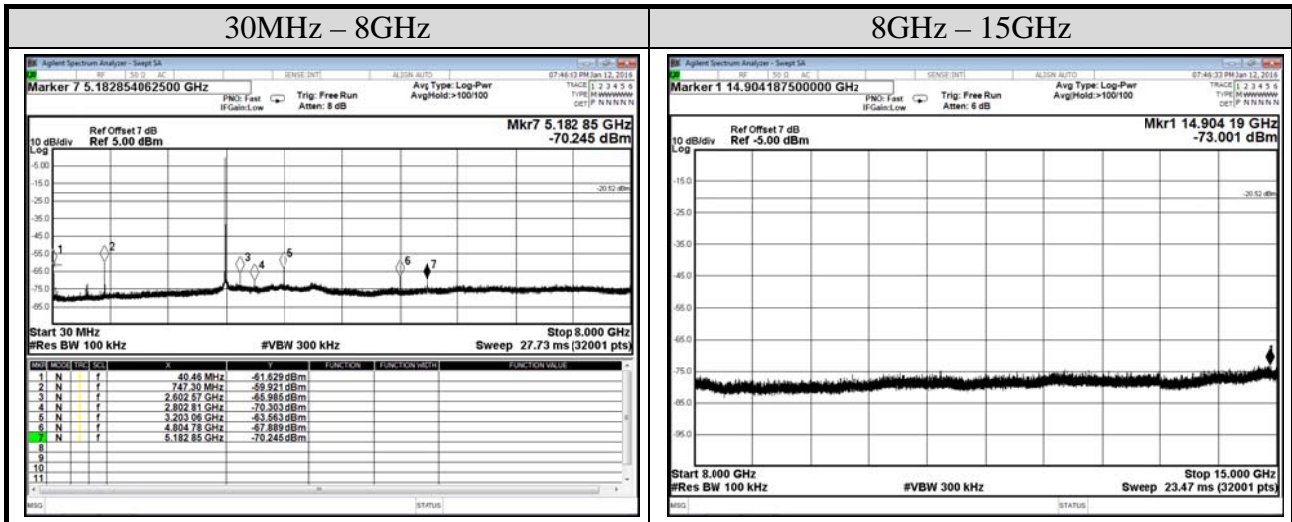

Note: All results have been included cable loss.

Test Date	2016/01/12	Temp./Hum.	22°C/60%
Modulation	8-DPSK	Frequency	2441MHz
Test Voltage	DC 12V		

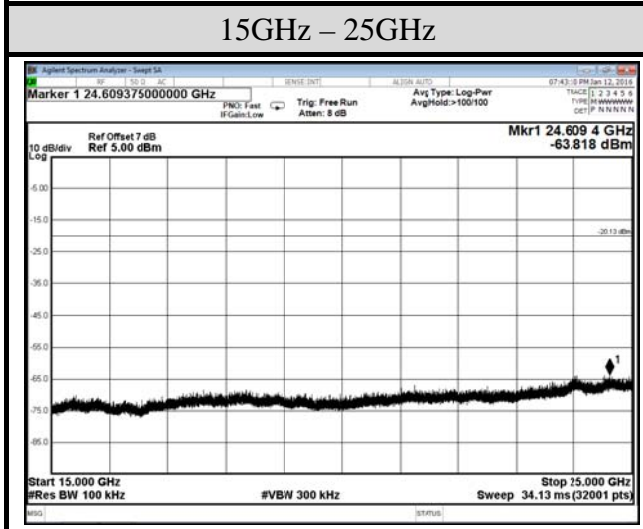
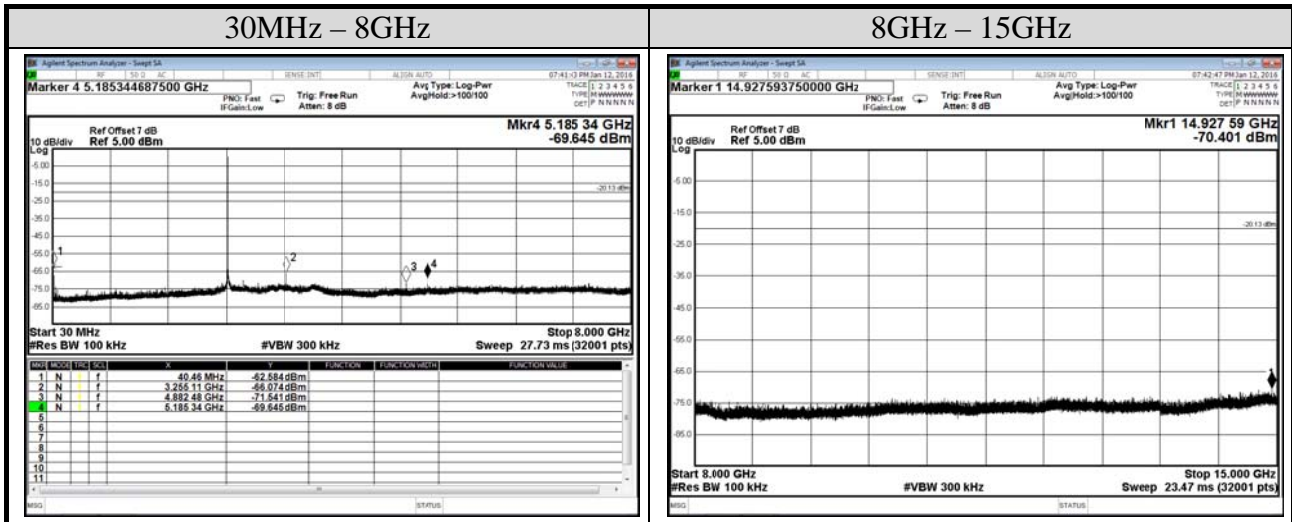

Note: All results have been included cable loss.

Test Date	2016/01/12	Temp./Hum.	22°C/60%
Modulation	8-DPSK	Frequency	2480MHz
Test Voltage	DC 12V		

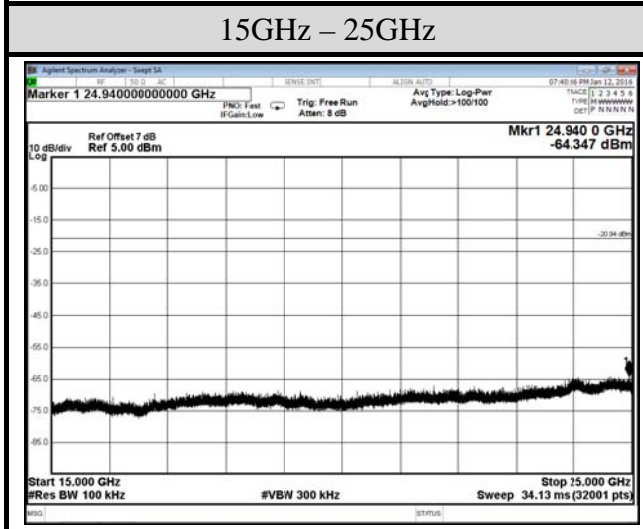
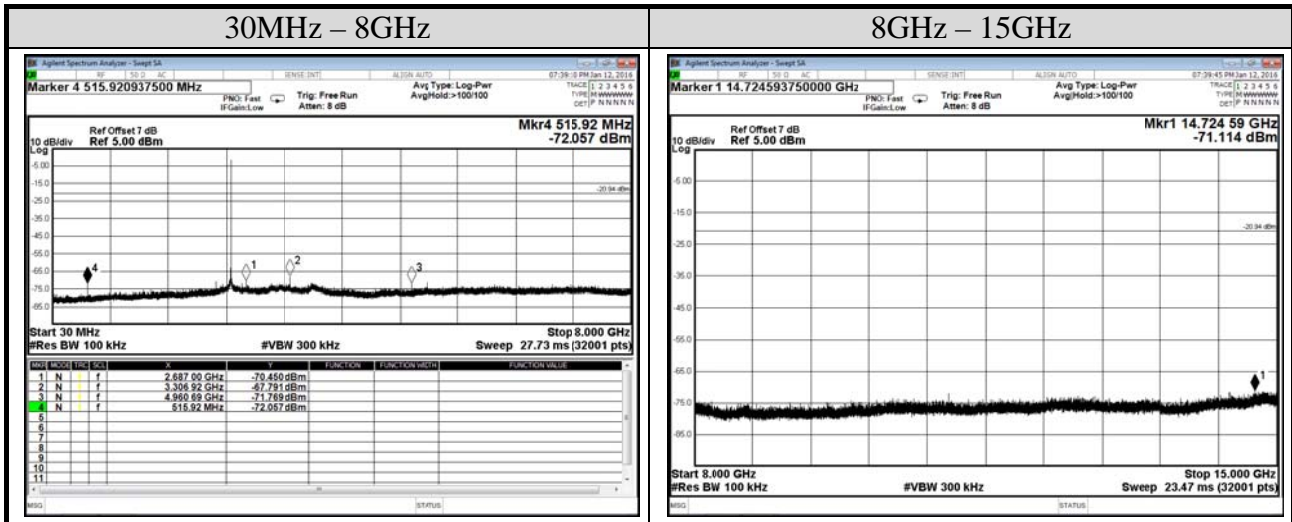

Note: All results have been included cable loss.