

FCC TEST REPORT

The Reputation of LG Defense Industry Continues with NEX1 Future.

Locations & Offices

NEX1 GUMI

133 Gongdan-dong, Gumi, Gyongsangbuk-do,
730-030, Korea

Tel : +82-54-469-8213
Fax : +82-54-469-8065



Network Navigation



• SEOUL
• YONGIN
• GUMI

August 22, 2006

NEX 1 Future Co., Ltd.



REPORT NO :
NF-TA-R060017

NEX1 Future Co., Ltd.

TEST REPORT CERTIFICATION

Applicant : LG Electronics Inc.

Address : LG Twin Towers 22F.,Yeouido-dong,Yeongdeungpo-gu,Seoul
150-721, Korea

EUT Name : LG Mono Headset
Model No. : LG HBM-730
Serial No. : Engineering Sample
FCCID : BEJHBM730
Testing location : Nex1 Future Co., Ltd.
133, Kongdan-Dong, Gumi-City, Kyeongsangbuk-Do, 730-030, R.O.K

Applied specification : FCC Part 15

Test result : The above mentioned test item passed.

Test Date August 22, 2006 **Review Date** August 22, 2006

Tested by Hyo-Jeung, Cho **Reviewed by** Jeong-Hi, Jin

Title Engineer **Title** EMC Manager

Signature

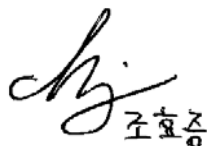

주효정

Signature

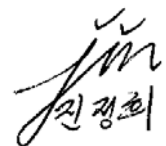

진정희

I HEREBY CERTIFY THAT the data shown in this report were made in accordance with the procedures given in the applied specification and I assume full responsibility for accuracy and completeness of these data.

Note : This test report relates to the a. m. test item. Without permission of the test center this test report is not permitted to be duplicated in extracts. This test report does not entitle to carry any test mark on this or similar products.

Contents

1. GENERAL INFORMATION.....	5
1.1 PRODUCT DESCRIPTION	5
1.2 PROJECT DATA.....	5
1.3 APPLICANT	5
1.4 MANUFACTURER	5
2. EUT INFORMATION.....	6
2.1 GENERAL EUT INFORMATION.....	6
2.2 CENTER FREQUENCY OF TESTED CHANNEL.....	6
2.3 TEST ENVIRONMENT	6
2.4 ACCESSORIES AND ANCILLARY EQUIPMENT	6
3. TESTING FACILITIES.....	7
4. EUT DESCRIPTION AND OPERATIONAL DESCRIPTION.....	7
5. TEST SET-UP.....	8
5.1 PRINCIPLE OF CONFIGURATION	8
5.2 OPERATIONAL MODES	8
5.3 APPLIED SPECIFICATION	8
6. TEST REPORT SUMMARY	9
7. TEST RESULTS.....	10
7.1 ANTENNA CONNECTOR REQUIREMENTS	10
7.2 AC CONNECTED EMISSION	11
7.3 CARRIER FREQUENCY SEPARATION.....	12
7.4 TIME OF OCCUPANCY(DWELL TIME)	14
7.5 20dB BANDWIDTH.....	16
7.6 NUMBER OF HOPPING FREQUENCIES REQUIREMENTS	20
7.7 PSEUDORANDOM FHS AND EQUAL HOPPING FREQUENCY USE REQUIREMENTS.....	22
7.8 RECEIVER INPUT BANDWIDTH REQUIREMENTS.....	23



REPORT NO :
NF-TA-R060017

NEX1 Future Co., Ltd.

7.9 PEAK OUTPUT POWER	24
7.10 BAND-EDGE COMPLIANCE	28
7.11 SPURIOUS CONDUCTED EMISSIONS	32
7.12 SPURIOUS RADIATED EMISSIONS	43
8. LIST OF TEST AND MEASUREMENT INSTRUMENTS	46
9. NOTES	47

1. General Information

1.1 Product Description

Product Name : LG Mono Headset
Product ID : LG HBM-730
Serial No. : Prototype
FCC ID : BEJHBM730

1.2 Project data

Receipt of EUT : August 10, 2006
Date of Test : August 17, 2006
Data of report : August 22, 2006

1.3 Applicant

Company Name : LG Electronics Inc.,
Address : LG Twin Towers 22F., Yeouido-dong, Yeongdeungpo-gu,
Seoul 150-721, Korea
Contact Person : Mr. Jeon, Young-Geun

1.4 Manufacturer

Company Name : LG Electronics Inc.,
Address : LG Twin Towers 22F., Yeouido-dong, Yeongdeungpo-gu,
Seoul 150-721, Korea
Contact Person : Mr. Jeon, Young-Geun

2. EUT Information

2.1 General EUT Information

Type	Transmitter	Receiver
FCC Classification	FHSS Sequence Spread Spectrum (FHSS)	FHSS Sequence Spread Spectrum (FHSS)
Operating frequency range	2402 – 2480 MHz	2402 – 2480 MHz
Bands of operation	2.400 – 2.4835 GHz	2.400 – 2.4835 GHz
Number of Channels	79	79
Channel Separation	1MHz	1MHz
Type of Antenna	Chip Antenna	Chip Antenna
Power Supply	DC 3.7 V Lithium Ion Battery	DC 3.7 V Lithium Ion Battery

2.2 Center Frequency of Tested Channel

Frequency	Tx (MHz)	Rx (MHz)
Lowest	2402	2402
Middle	2441	2441
Highest	2480	2480

2.3 Test Environment

Temperature	25°C
Relative Humidity	30 ~ 60%
DC Voltage	DC 3.7V

2.4 Accessories and Ancillary Equipment

Equipment	Model No.	Serial Number	Maker
Laptop PC	PS428L-OE142	30014068J	Toshiba

3. Testing Facilities

Nex1 Future Co., Ltd.

133, Kongdan-Dong, Gumi-City, Kyeongsangbuk-Do, 730-030, R.O.K

4. EUT Description and Operational Description

This Product is a LG Mono Headset (LG HBM-730) featuring a state of the art Bluetooth Wireless technology. It has excellent echo cancel and noise reduction ability, and surely is in its class by itself.

Using this speaker phone, users can make or answer a call without touching their cell phones.

This device also features well-defined Man Machine interface with 3 buttons and 1 LEDs, 1LCD which are :

- Buttons : 3 pcs [Power/Call/End, Volume Up, Volume Down]
- LCD : 1 pcs
- LEDs : 1 pcs [Charging(REDD)]

And it is also fully compliant with Bluetooth 2.0 specification.

* General specifications

Item	Description
Bluetooth Specification	V2.0
Supported Profile	Headset/Handfree profile
Rx. Sensitivity	Typ. -70 dBm
Battery	3.7V, 80mAh Li-ion Polymer
Speaker	32Ω / 0.5W (normal)
MIC	-35dB / Omnidirectional
Low Power Current (Sniff Mode)	≤ 0.42 mA (Connected.)
Standby Time (Sniff Mode)	≥ 150 Hr
Talking Time	≥ 3 Hr
Full Charging Time	< 2Hrs ±30 min
Operating Temperature	-10℃ ~ 60℃
Operating Humidity	5% ~ 85% RH
Storage Temperature	-20℃ ~ 60℃
Storage Humidity	85% RH

5. Test Set-up

5.1 Principle of configuration

Conducted : The equipment under test (EUT) was configured with a temporary SMA Connector and EUT transmits the related packet type with PRBS 9 as payload.

Emission:The equipment under test (EUT) was configured to measure its highest possible radiation level. The test modes and test settings were adapted accordingly in reference to the instructions for use.

For details, please refer to the Operation mode in chapter 7.

5.2 Operational Modes

Page Scan,

Inquiry Scan

Hopping Mode

Fixed mode (2402Mhz, 2441Mhz and 2480Mhz)

5.3 Applied Specification

FCC Part 15

6. Test Report Summary

Related Clause	Test Cases	FCC Part Sections	Result (Note1)
7.1	Antenna Connector Requirements	15.203 15.204	C
7.2	AC Connected Emission	15.207	N/A
7.3	Carrier Frequency Separation	15.247	Pass
7.4	Time of Occupancy(Dwell time)	15.247	Pass
7.5	20dB Bandwidth	15.247	Pass
7.6	Number of Hopping Frequencies Requirements	15.247	C
7.7	Pseudorandom Frequency Hopping Sequence and Equal Hopping Frequency use Requirements	15.247	C
7.8	Receiver Input Bandwidth Requirements	15.247	C
7.9	Peak Output Power	15.247	Pass
7.10	Band-edge Compliance	15.247	Pass
7.11	Spurious Conducted emissions	15.247	Pass
7.12	Spurious Radiated emissions	15.247	Pass

* Note1: C: Complies, Pass: Passed, Fail : Failed and NA : Not Applicable

7. Test Results

7.1 Antenna Connector Requirements

Requirements

Subclause 15.203 and 15.204(c)

According to the Part 15.203, an intentional radiator shall be designed to ensure that no antenna other than that furnished by the responsible party shall be used with the device. The use of a permanently attached antenna or of an antenna that uses a unique coupling to the intentional radiator shall be considered sufficient to comply with the provisions of this Section.

The manufacturer may design the unit so that a broken antenna can be replaced by the user, but the use of a standard antenna jack or electrical connector is prohibited.

And according to the Part 15.204(c), only the antenna with which an intentional radiator is authorized may be used with the intentional radiator.

Test results

RESULT:

Complies

The antenna is permanently attached on the PCB.
The EUT has a Chip Antenna soldered to the circuit board.
For more information on the antenna:
Antenna gain : 0 dBi
Manufacturer : Partron Co., Ltd.
Model No. : ACS2450HBA73
Type : Surface Chip Antenna

7.2 AC Connected Emission

Test Mode and conditions

The power is supplied by a DC 3.7 V Li-ion Polymer and EUT doesn't operate during charging.

Requirements

Subclause15.207(a)

For an intentional radiator that is designed to be connected to the public utility (AC) power line, the radio frequency voltage that is conducted back onto the AC power line on any frequency or frequencies within the band 150 kHz to 30 MHz shall not exceed the limits in the following table, as measured using a 50 μ H/50 ohms line impedance stabilization network (LISN).

Frequency of Emission (M Hz)	Conducted Limit (dB μ V)	
	Quasi-peak	Average
0.15-0.5	66-56*	56-46*
0.5-5	56	46
5-30	60	50

* Decreases with the logarithm of the frequency.

Test results

N/A

7.3 Carrier Frequency Separation

Test Mode and conditions

Mode of operation : Tx mode (hopping on), DH1 packet with PRBS9 payload
Measurement Method : Conducted
Detector : PK
Trace : Max hold
RBW/VBW : 100kHz/300kHz

Requirements

Subclause 15.247(a)(1)

Frequency hopping systems shall have hopping channel carrier frequencies separated by a minimum of 25kHz or the 20dB bandwidth of the hopping channel, whichever is greater.

Test results

Reference frequency (MHz)	Channel Separation (kHz)	Limit	Results
2441.000	996.0	Minimum of 25kHz or the 20dB bandwidth	Pass

Carrier Frequency Separation Plot

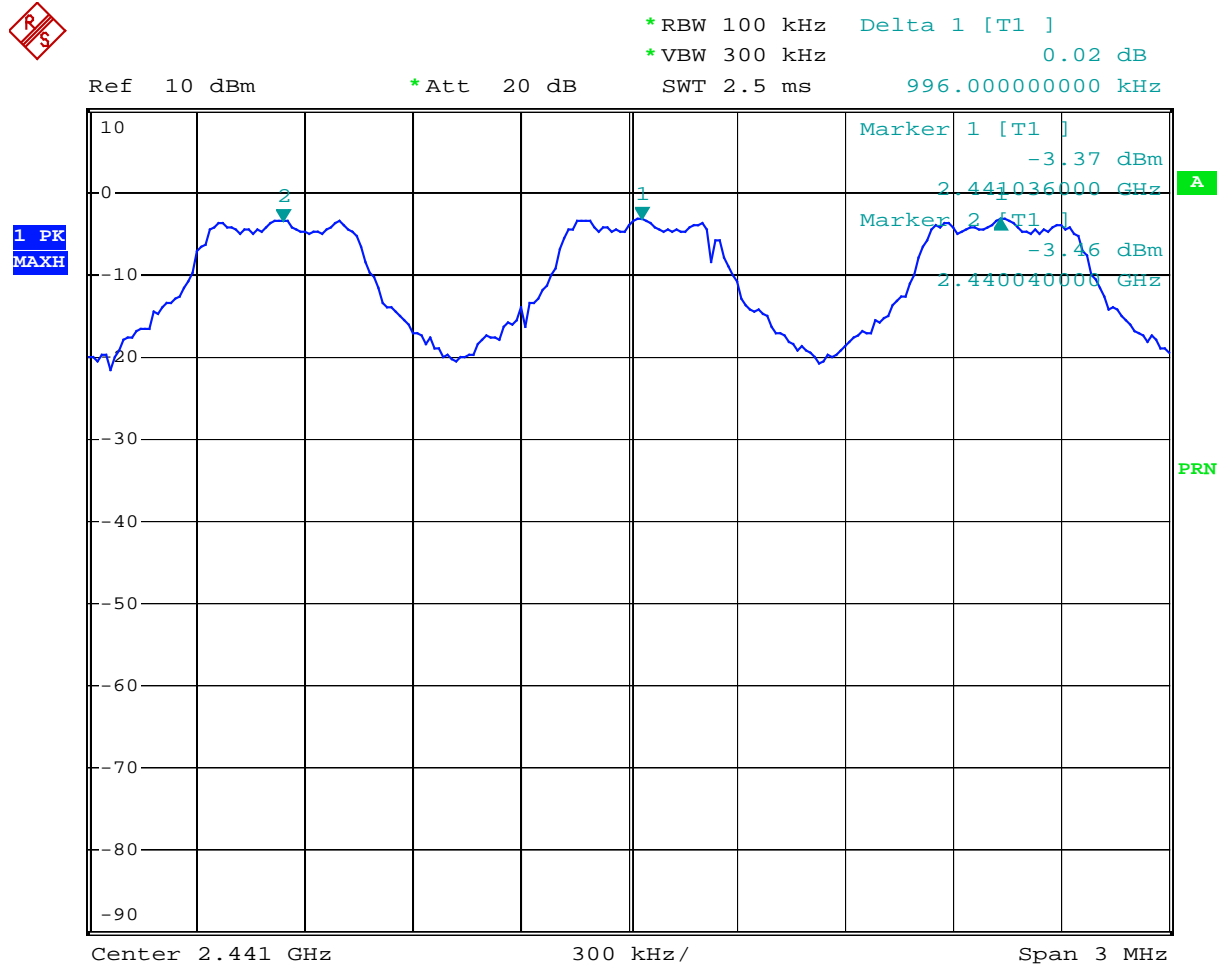

Date: 17.AUG.2006 11:06:53

7.4 Time of Occupancy(Dwell time)

Test Mode and conditions

Mode of operation : Hopping on , DH5 packet with PRBS9 payload
 Measurement Method : Conducted
 Detector : PK
 Trace : Max hold
 RBW/VBW : 1MHz/300kHz

Requirements

Subclause 15.247(a)(1)(iii)

Frequency hopping systems in the 2400 – 2483.5 MHz band shall use at least 75 hopping frequencies. The average time of occupancy on any frequency shall not be greater than 0.4 seconds within a 30 second period.

Test results

The system makes 1600 hops per second or has a length of 625us.

Let take DH5 packet in worst case. A DH5 packet has 5 slots for transmitting and 1 slot for receiving. It means it can have maximum 266.67 (=1600/6)hops per second.

Therefore it has 3.38 hops(=266.67/79) per second for each channel.

And it has 106.81hops appearance for 31.6 seconds (= 0.4x79channels).

Length per slot(L)	Number slots (N)	Dwell Time (=L*N)	Limit	Results
2.92ms	106.81	311.8852ms	0.4 seconds	Pass

Time of Occupancy Plot



Ref 10 dBm *Att 20 dB RBW 1 MHz Delta 1 [T1]
 *VBW 300 kHz -0.13 dB
 SWT 5 ms 2.920000 ms

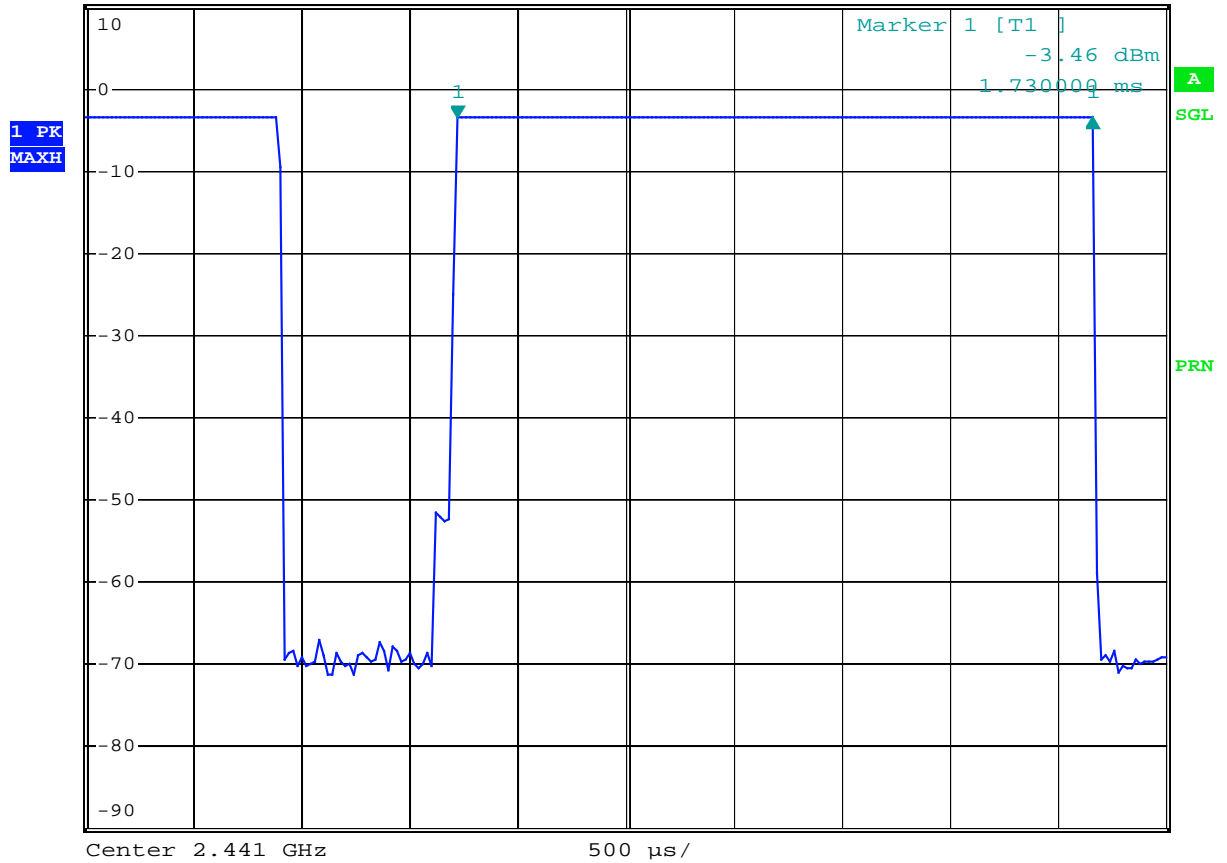

Date: 17.AUG.2006 11:09:54

7.5 20dB Bandwidth

Test Mode and conditions

Mode of operation : Tx mode (2402MHz, 2441MHz, 2480MHz),
DH5 packet with PRBS9 payload
Measurement Method : Conducted
Detector : PK
Trace : Max hold
RBW/VBW : 30kHz/100kHz

Requirements

Subclause 15.247(a)(1)

It is mentioned implicitly as the maximum 20dB bandwidth of the hopping channel is 1Mhz.

Test results

Operating frequency (MHz)	20dB Bandwidth (MHz)	Limit	Results
2402	0.940	< 1 Mhz	Pass
2441	0.940	< 1 Mhz	Pass
2480	0.932	< 1 Mhz	Pass

20dB Bandwidth Plot – 2402Mhz



*RBW 30 kHz Delta 1 [T1]
*VBW 100 kHz -0.65 dB
SWT 2.5 ms 940.00000000 kHz

Ref 10 dBm

*Att 20 dB

1 PK
MAXH

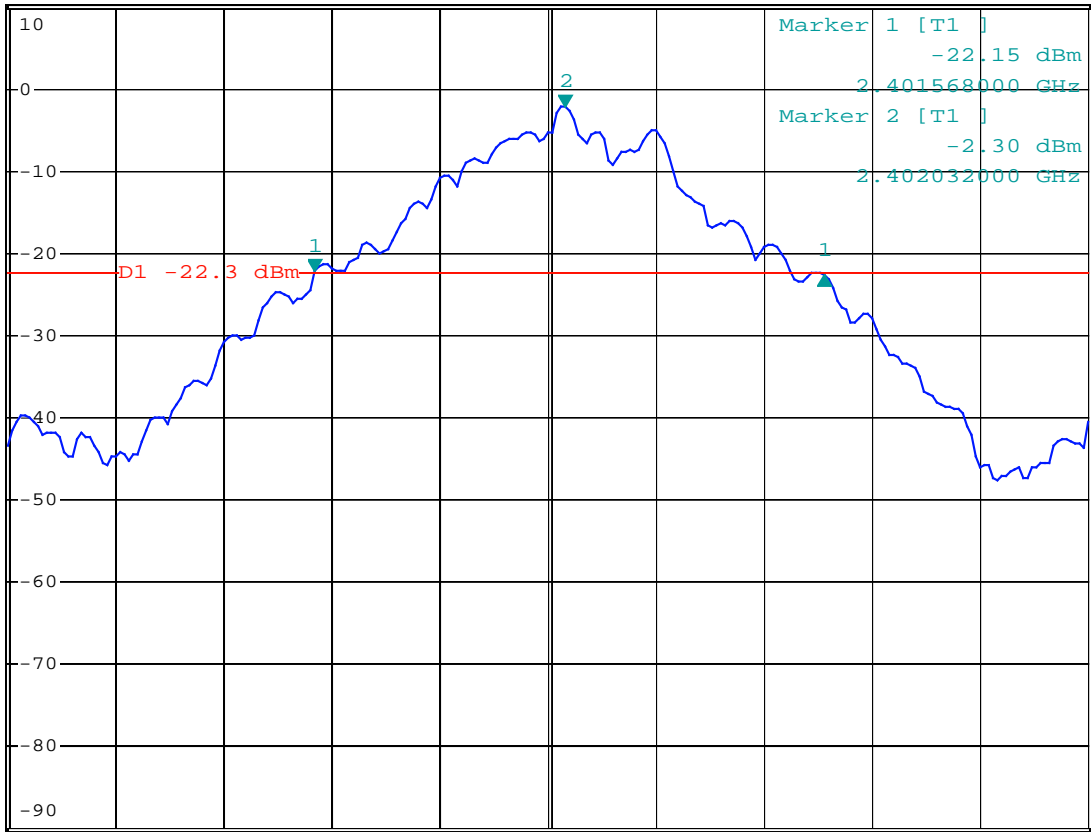

Center 2.402 GHz

200 kHz/

Span 2 MHz

Date: 17.AUG.2006 11:14:10

20dB Bandwidth Plot – 2441Mhz



*RBW 30 kHz Delta 1 [T1]
*VBW 100 kHz -0.08 dB
SWT 2.5 ms 940.00000000 kHz

Ref 10 dBm

*Att 20 dB

1 PK
MAXH

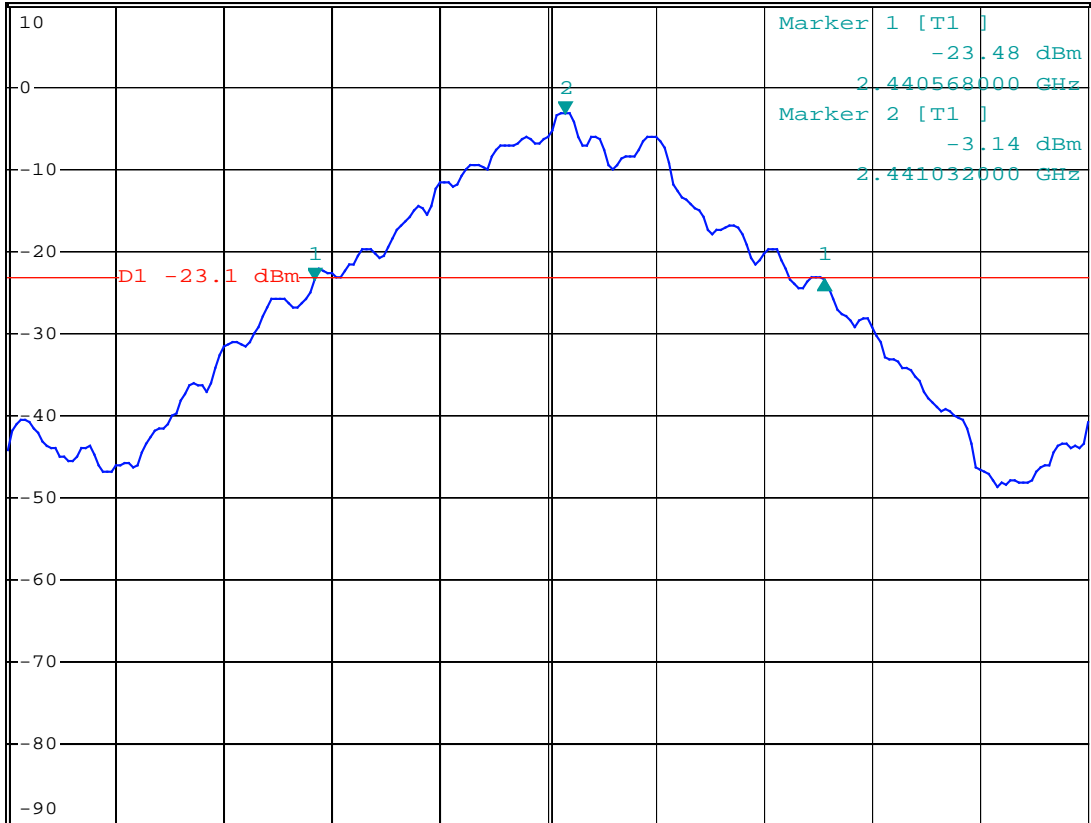

Center 2.441 GHz

200 kHz/

Span 2 MHz

Date: 17.AUG.2006 11:15:50

20dB Bandwidth Plot – 2480Mhz

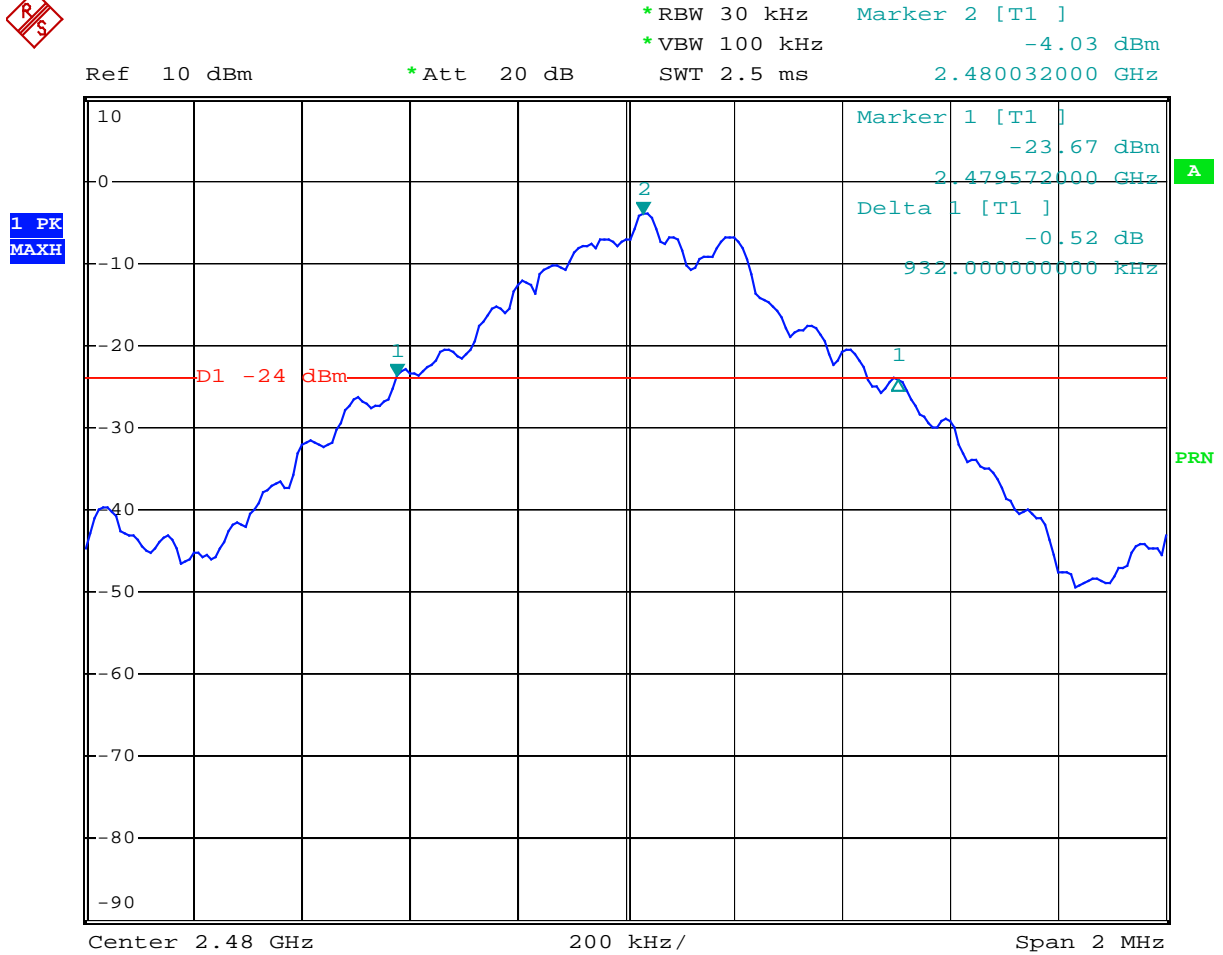

Date: 17.AUG.2006 11:18:02

7.6 Number of Hopping Frequencies Requirements

Test Mode and conditions

Mode of operation : Hopping, DH1 with PRBS9 payload
Measurement Method : Conducted
Detector : PK
Trace : Max hold
RBW/VBW : 100kHz/100kHz

Requirements

15.247(a)(1)(iii)

Frequency hopping systems in the 2400-2483.5 Mhz band shall use at least 15 non-overlapping Channels.

Test results

Operating frequency (MHz)	Number of Hopping	Limit	Results
2402~2480	79	≥ 15	Pass

Number of Hopping Frequencies Plot



*RBW 100 kHz Marker 1 [T1]
*VBW 100 kHz -2.52 dBm
SWT 10 ms 2.402988000 GHz

Ref 10 dBm

*Att 20 dB

1 PK
MAXH

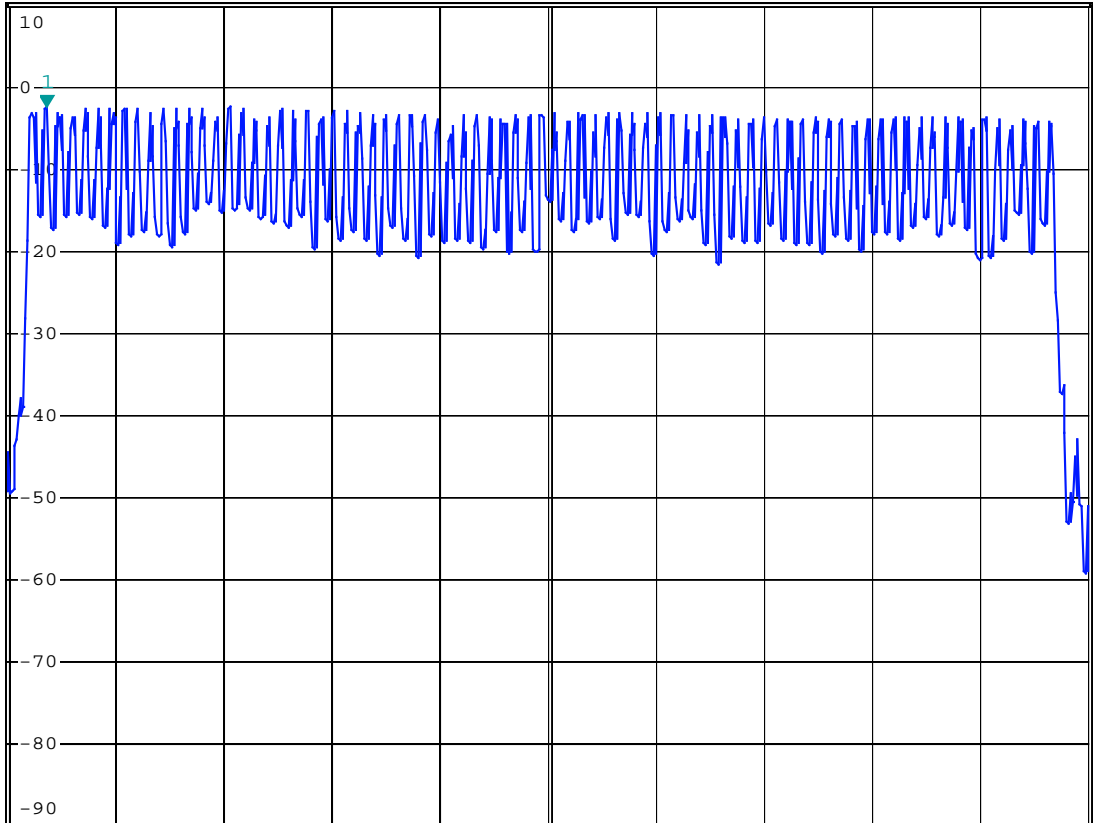

Start 2.4 GHz

8.3 MHz/

Stop 2.483 GHz

Date: 17.AUG.2006 11:23:36

7.7 Pseudorandom FHS and Equal Hopping Frequency use Requirements

Requirements

Subclause 15.247 (a)(1)

The system shall hop to channel frequencies that are selected at the system hopping rate from a pseudorandomly ordered list of hopping frequencies. Each frequency must be used equally on the average by each transmitter.

RESULT

Complies

The channel is represented by a pseudo-random hopping sequence hopping through the 79 RF channels. The hopping sequence is unique for the piconet and is determined by the Bluetooth device address of the master. For details, refer to the figure 1. The X input determines the phase in the 32-hop segment, whereas Y1 and Y2 selects between master-to-slave and slave-to-master transmission. The inputs A to D determine the ordering within the segment, the inputs E and F determine the mapping onto the hop frequencies.

The algorithm in the Bluetooth specifications shows the each of its hopping channels is used equally on average also.

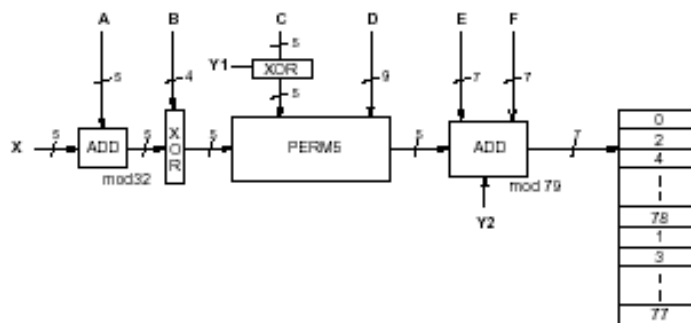

< Figure 1 : Block diagram of hop selection kernel for 79 hop system >

7.8 Receiver Input Bandwidth Requirements

Requirements

Subclause 15.247 (a)(1)

The system receivers shall have input bandwidths that match the hopping channel bandwidths of their corresponding transmitters and shall shift frequencies in the synchronization with the transmitted signals.

RESULT

Complies

The receiver bandwidth is equal to the receiver bandwidth in the 79 hopping channel mode, which is 1 MHz. The receiver bandwidth is indirectly verified during Bluetooth RF conformance testing.

7.9 Peak Output Power

Test Mode and conditions

Mode of operation : Tx mode (2402MHz, 2441MHz, 2480MHz),
DH1 packet with PRBS 9 payload
Measurement Method : Conducted
Detector : PK
Trace : Max hold
RBW/VBW : 1MHz/3MHz

Requirements

Subclause 15.247(b)(1)

For frequency hopping systems operating in the 2400~2483.5 Mhz band employing at least 75hopping channels, the maximum output power of the intentional radiator shall not exceeded 1 watt.

Test results

Operating Frequency (MHz)	Reading (dBm)	Cable attenuation (dB)	Actual Value (W)	Limit (W)	Results
2402	-2.32	1.80	0.000887156	<1.0	Pass
2441	-3.22	1.83	0.000726100	<1.0	Pass
2480	-4.09	1.85	0.000597035	<1.0	Pass

Peak Output Power Plot - 2402

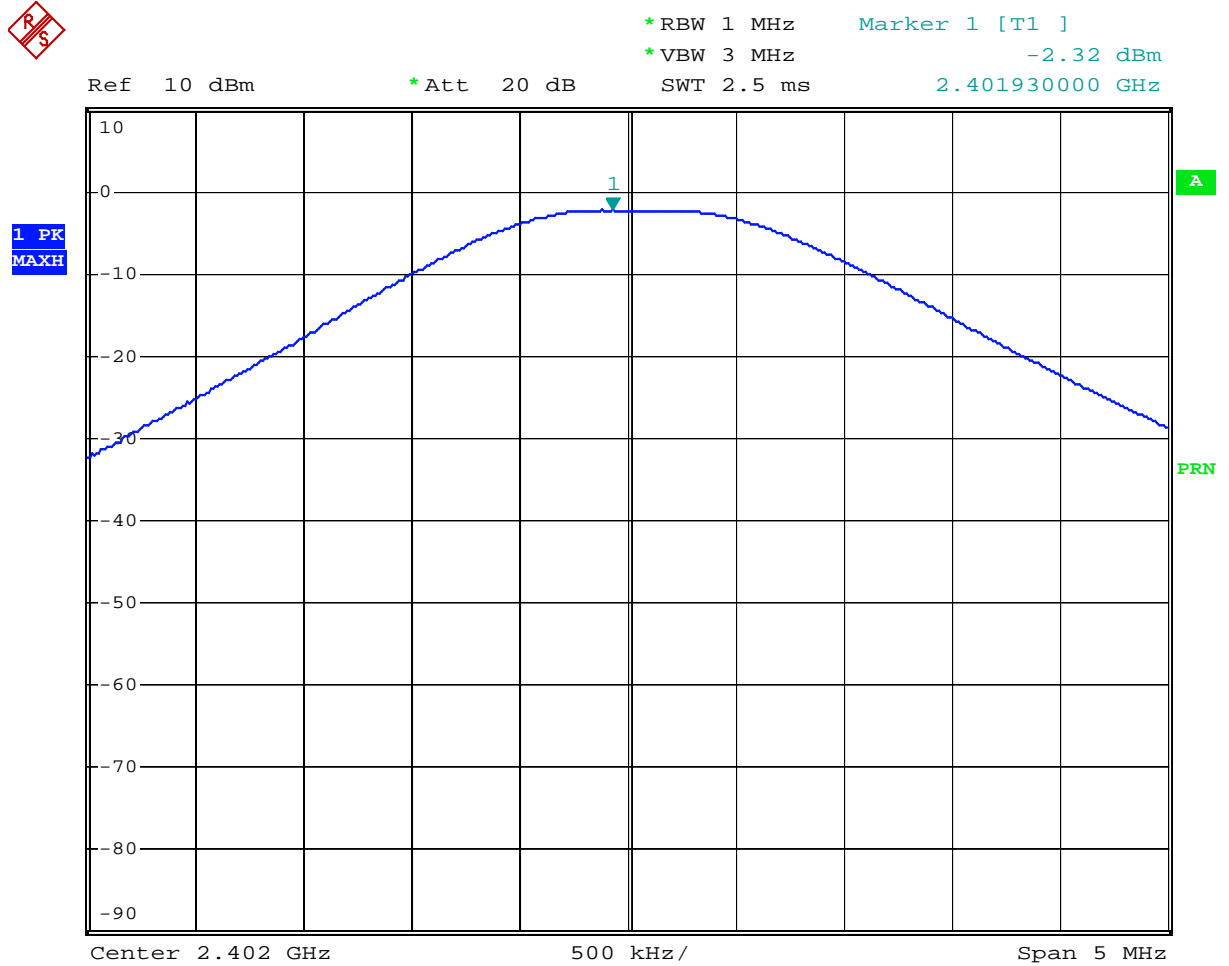

Date: 17.AUG.2006 11:25:10

Peak Output Power Plot – 2441



*RBW 1 MHz Marker 1 [T1]
*VBW 3 MHz -3.22 dBm
SWT 2.5 ms 2.440890000 GHz

Ref 10 dBm

*Att 20 dB

1 PK
MAXH

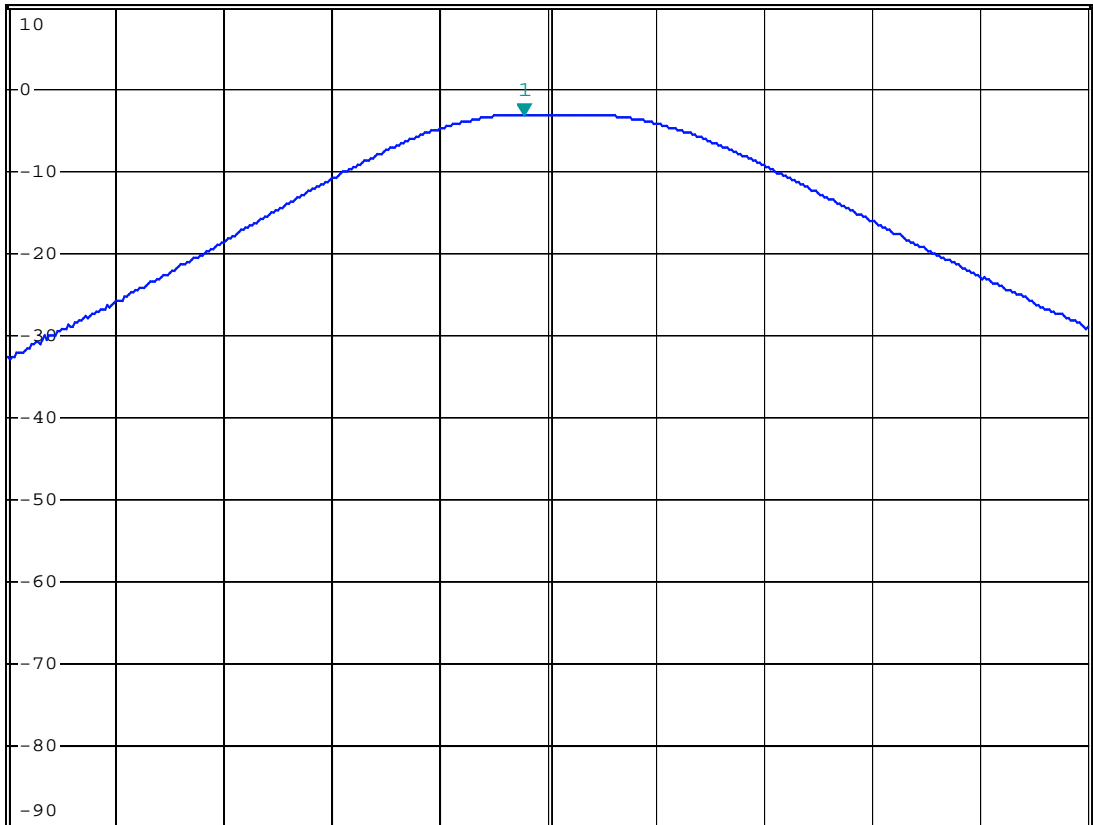

Center 2.441 GHz

500 kHz/

Span 5 MHz

Date: 17.AUG.2006 11:25:46

Peak Output Power Plot – 2480



*RBW 1 MHz Marker 1 [T1]
*VBW 3 MHz -4.09 dBm
SWT 2.5 ms 2.479850000 GHz

Ref 10 dBm

*Att 20 dB

1 PK
MAXH

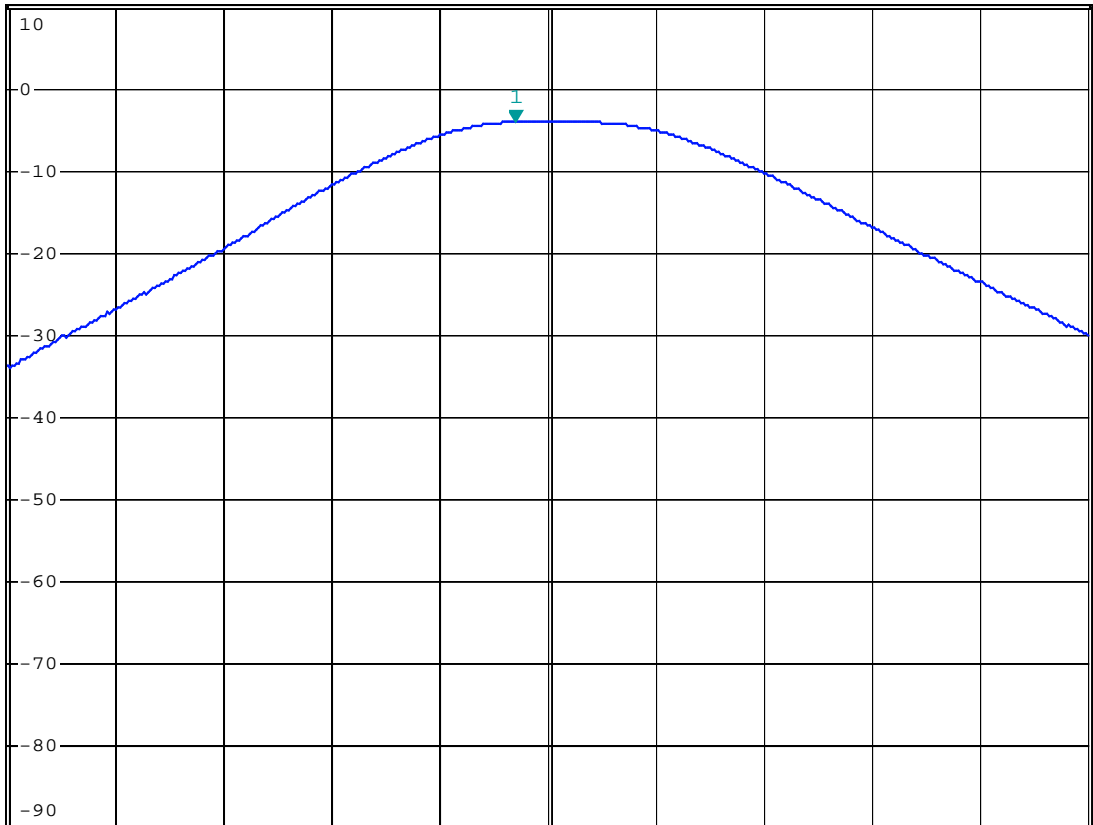

Center 2.48 GHz

500 kHz/

Span 5 MHz

Date: 17.AUG.2006 11:26:18

7.10 Band-edge Compliance

Test Mode and conditions

Mode of operation : Tx mode (2402MHz, 2441MHz, 2480MHz), DH1 packet
Measurement Method : Conducted
Detector : PK
Trace : Max hold
RBW/VBW : 300kHz/1.0MHz

Requirements

Subclause 15.247(c)

In any 100kHz bandwidth outside the frequency band in which the spread spectrum or digitally modulated intentional radiator is operating, the radio frequency power that is produced by the intentional radiator shall be at least 20dB below that in the 100kHz bandwidth within the band that contains the highest level of the desired power, based on either an RF conducted or a radiated measurement. Attenuation below the general limits specified in Section 15.209(a) is not required.

Test results

There is no peak found outside any 100kHz bandwidth of the operating frequency band in the three transmit frequency.

Tx Frequency (MHz)	RF power outside 100kHz BW (MHz)	Limit	Results
2402	No peak above 20dB	20dB below	Pass
2441	No peak above 20dB	20dB below	Pass
2480	No peak above 20dB	20dB below	Pass

Band-edge Compliance Plot - 2402

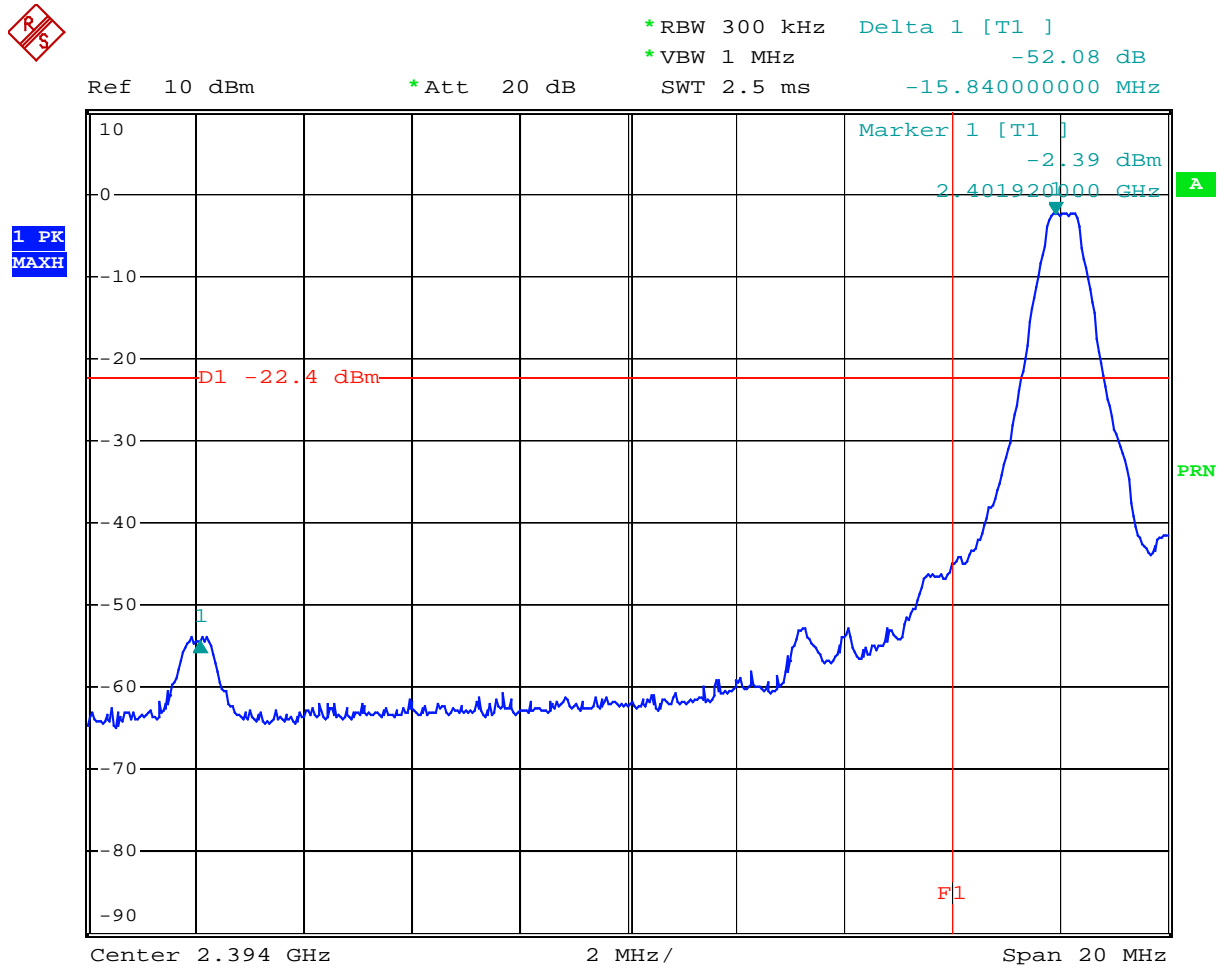

Date: 17.AUG.2006 11:31:08

Band-edge Compliance Plot – 2441

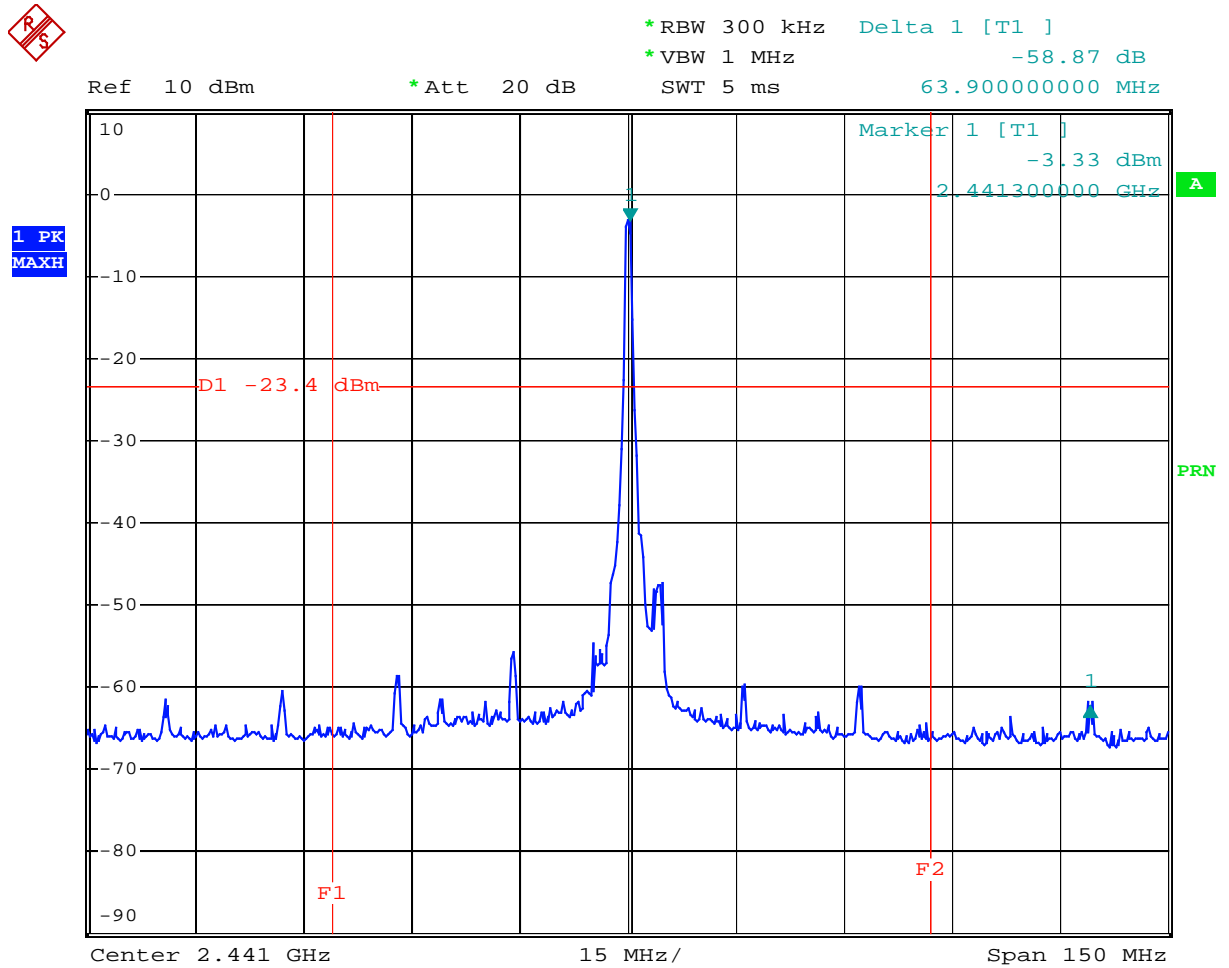

Date: 17.AUG.2006 11:33:29

Band-edge Compliance Plot – 2480

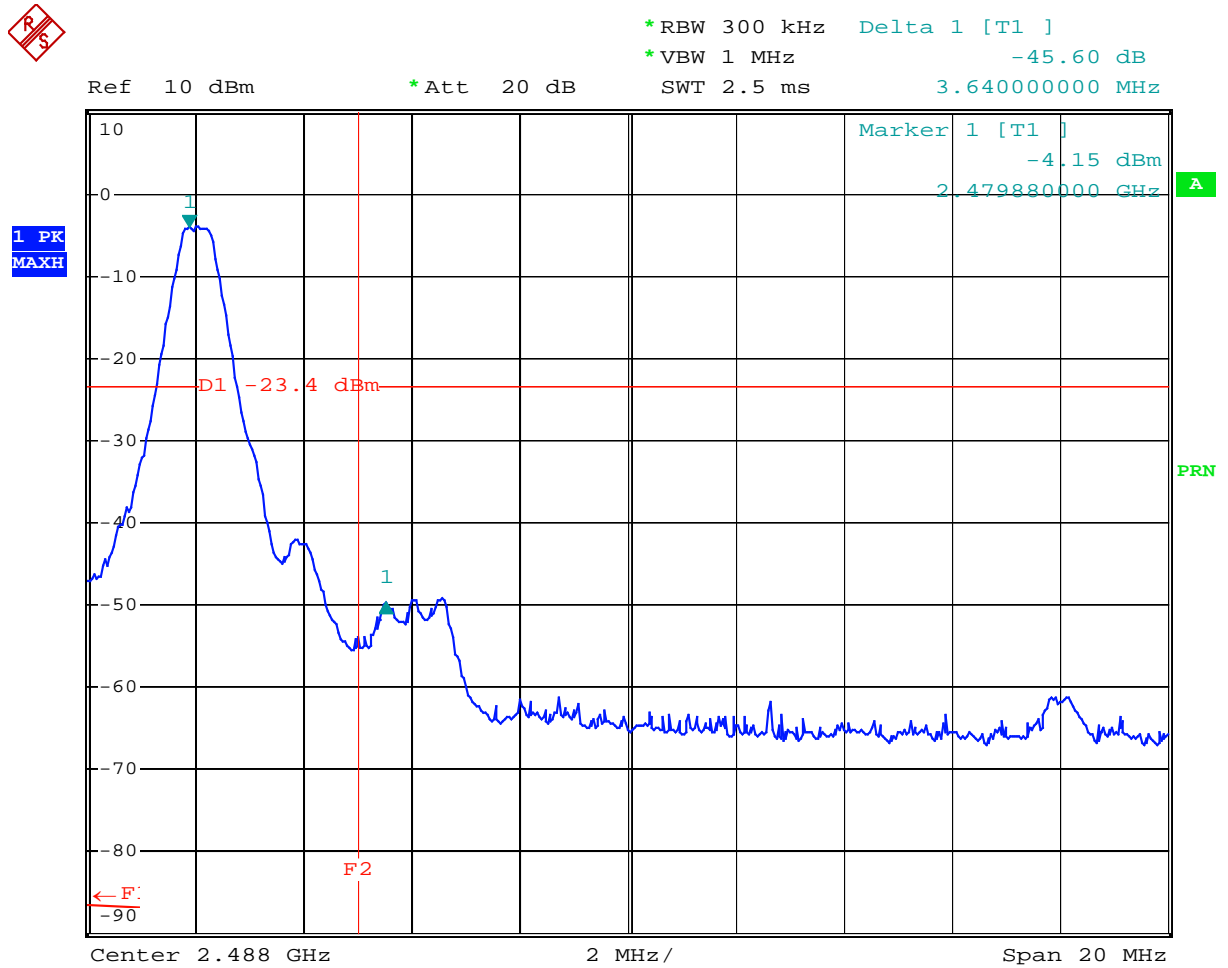

Date: 17.AUG.2006 11:34:41

7.11 Spurious Conducted emissions

Test Mode and conditions

Mode of operation : Tx mode (2402MHz, 2441MHz, 2480MHz), DH1 packet
 Measurement Method : Conducted
 Detector : PK
 Trace : Max hold
 RBW/VBW : 100kHz/300kHz

Requirements

Subclause 15.247(c)

In any 100kHz bandwidth outside the frequency band in which the spread spectrum or digitally modulated intentional radiator is operating, the radio frequency power that is produced by the intentional radiator shall be at least 20dB below that in the 100k Hz bandwidth within the band that contains the highest level of the desired power, based on either an RF conducted or a radiated measurement. Attenuation below the general limits specified in Section 15.209(a) is not required.

Test results

Frequency (MHz)	Reading Value (dBm)	Correction Factor (dB)	Results (dBm)	Reference Value (dBm)	Delta to Reference (dB)
<i>Operating frequency : 2402MHz</i>					
4795.66	-52.18	3.4	-48.78	-20.910	27.87
14920	-52.04	6.0	-46.04	-20.910	25.13
20050	-47.72	6.7	-41.02	-20.910	20.11

Frequency (MHz)	Reading Value (dBm)	Correction Factor (dB)	Results (dBm)	Reference Value (dBm)	Delta to Reference (dB)
<i>Operating frequency : 2441MHz</i>					
4875.42	-50.67	3.4	-47.27	-21.730	25.54
13700	-51.48	6.0	-45.48	-21.730	23.75
20020	-46.82	6.7	-40.12	-21.730	18.39

Frequency (MHz)	Reading Value (dBm)	Correction Factor (dB)	Results (dBm)	Reference Value (dBm)	Delta to Reference (dB)
<i>Operating frequency : 2480MHz</i>					
4955.18	-49.47	3.4	-46.07	-22.240	23.83
19340	-52.1	6.7	-45.4	-22.240	23.16
20010	-47	6.7	-40.3	-22.240	18.06

Spurious Conducted emissions plot- 2441 (30MHz~10GHz)



*RBW 100 kHz Delta 1 [T1]
*VBW 300 kHz -47.11 dB
*SWT 120 s 2.432680000 GHz

Ref 10 dBm

*Att 20 dB

1 PK
MAXH

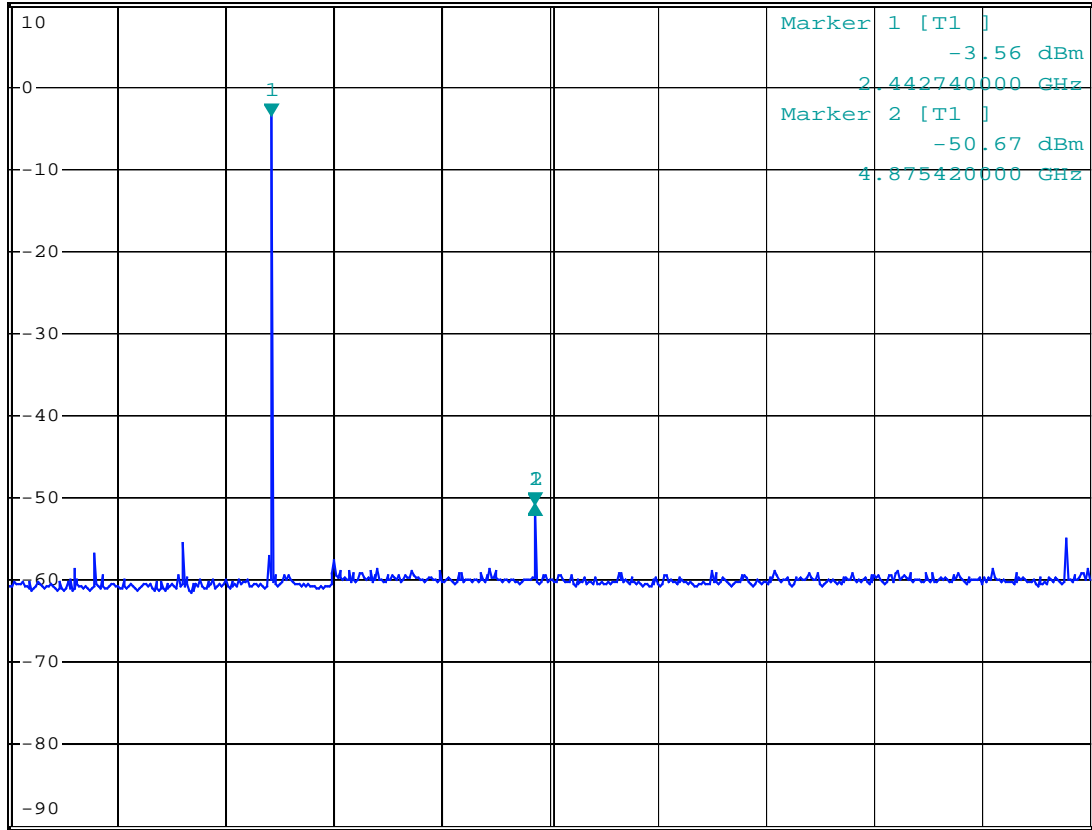

A

SGL

PRN

Start 30 MHz

997 MHz/

Stop 10 GHz

Date: 17.AUG.2006 10:47:49

Spurious Conducted emissions plot- 2441 (10GHz~20GHz)



*RBW 100 kHz Marker 1 [T1]
*VBW 300 kHz -51.48 dBm
*SWT 120 s 13.70000000 GHz

Ref 10 dBm

*Att 20 dB

1 PK
MAXH

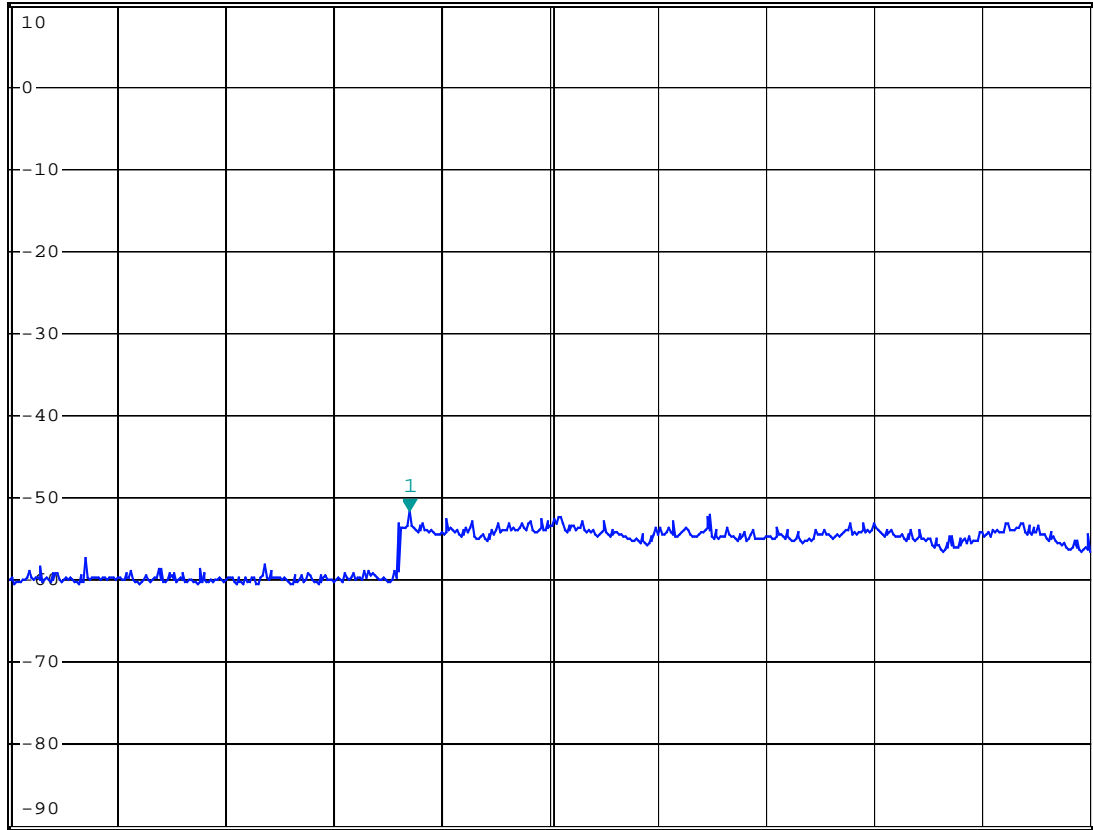

Start 10 GHz

1 GHz/

Stop 20 GHz

Date: 17.AUG.2006 10:50:29

Spurious Conducted emissions plot- 2441 (20GHz~25GHz)

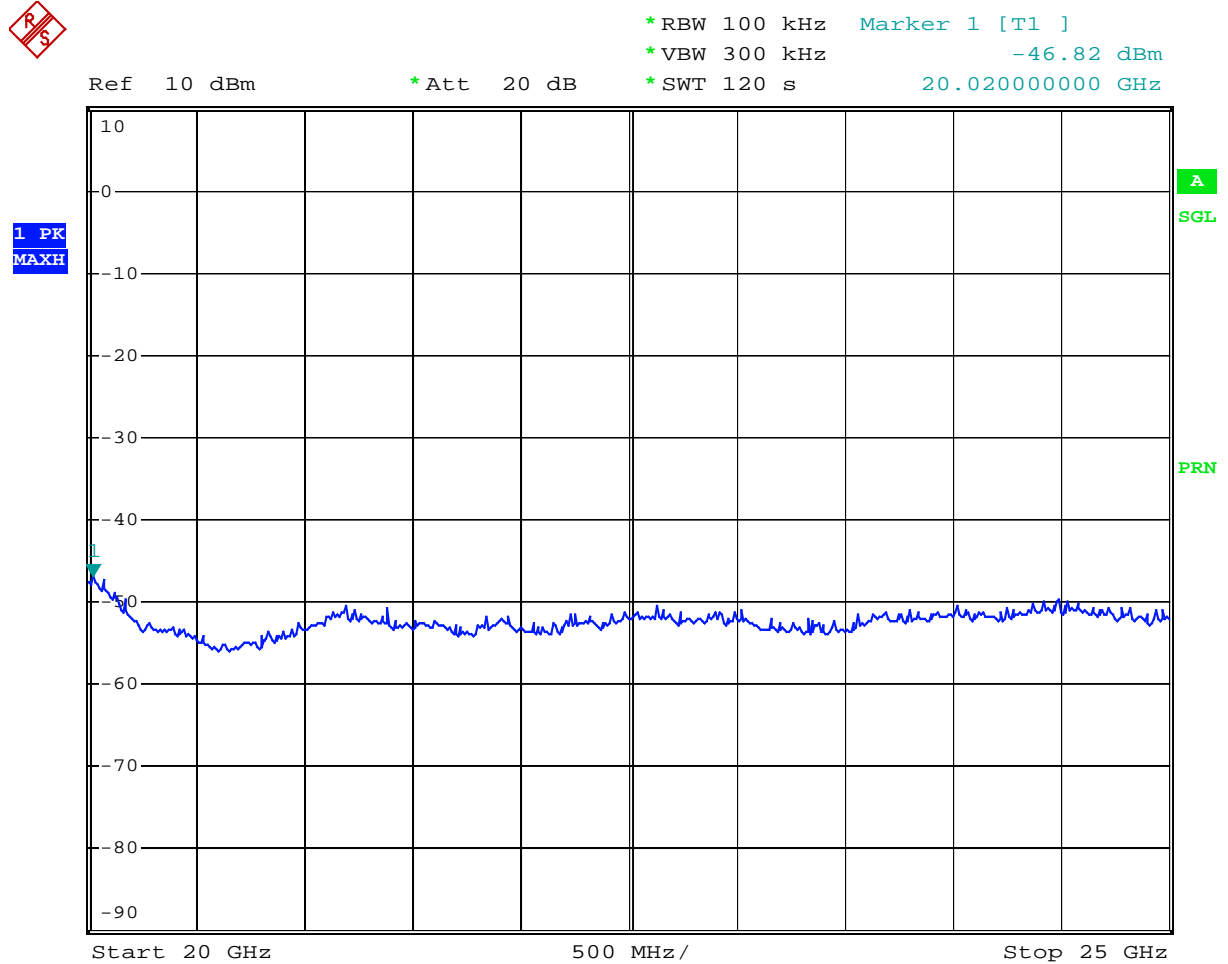

Date: 17.AUG.2006 10:53:08

Spurious Conducted emissions plot- 2480 (30MHz~10GHz)



*RBW 100 kHz Delta 1 [T1]
*VBW 300 kHz -45.26 dB
*SWT 120 s 2.472560000 GHz

Ref 10 dBm

*Att 20 dB

1 PK
MAXH

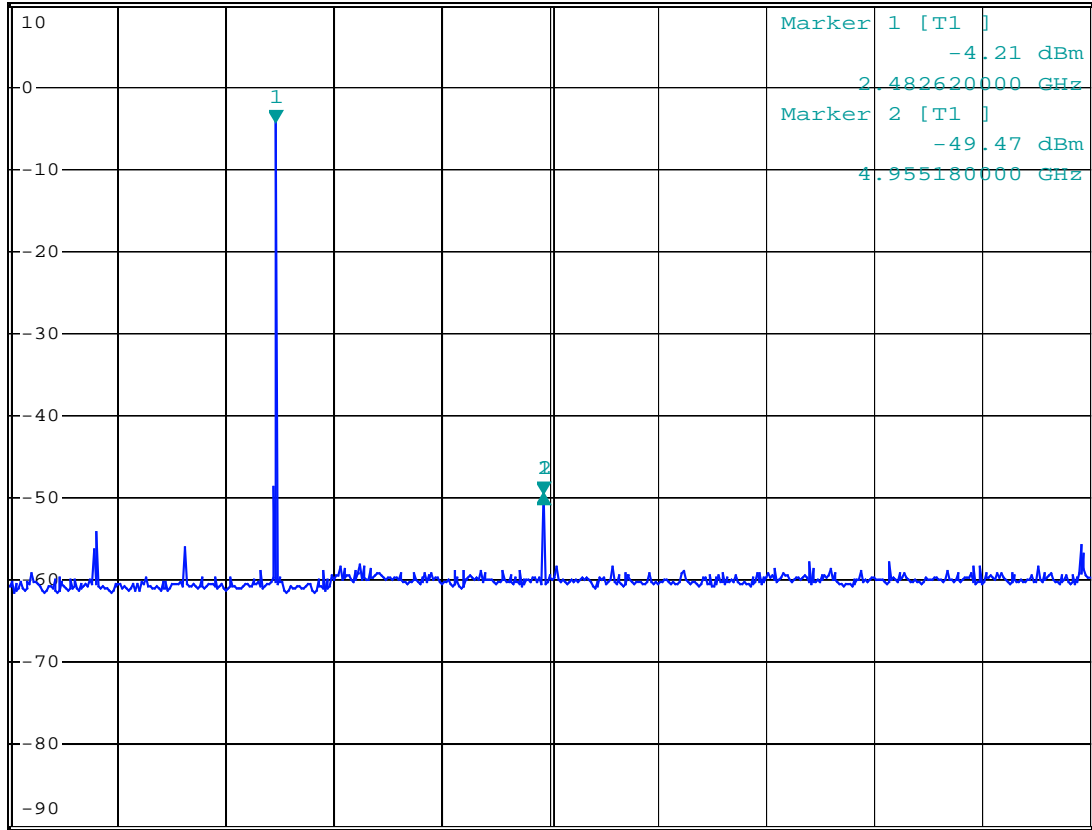

A

SGL

PRN

Start 30 MHz

997 MHz/

Stop 10 GHz

Date: 17.AUG.2006 10:56:03

Spurious Conducted emissions plot- 2480 (20GHz~25GHz)



*RBW 100 kHz Marker 1 [T1]
*VBW 300 kHz -47.00 dBm
*SWT 120 s 20.01000000 GHz

Ref 10 dBm

*Att 20 dB

1 PK
MAXH

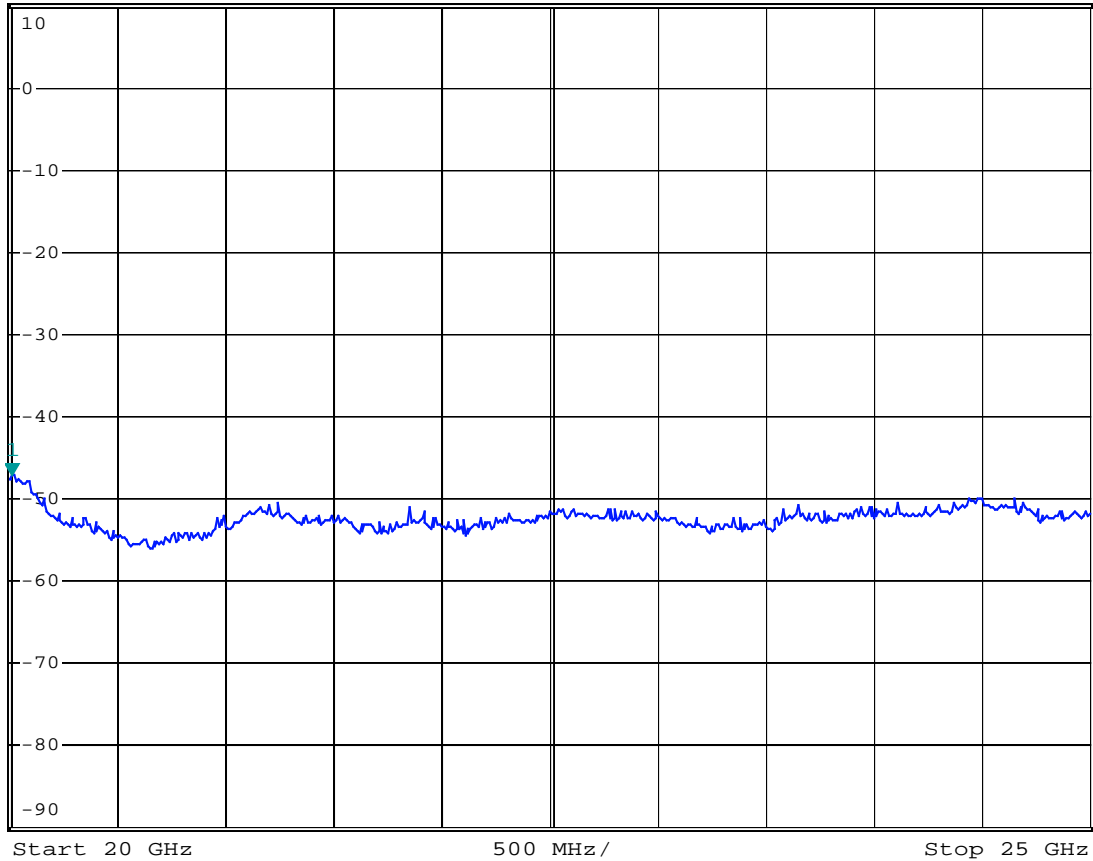

Date: 17.AUG.2006 11:01:58

7.12 Spurious Radiated emissions

Test Mode and conditions

Mode of operation : Tx mode (2402MHz, 2441MHz, 2480MHz),
DH1 packet

Detector : PK

Trace : Max hold

Measurement Method : Radiated- Enclosure

Measurement Distance : 3m

Measurement BW : 1 MHz for $f \geq 1$ GHz, 100kHz for $f < 1$ GHz

Requirements

Subclause 15.247(c)

In addition, radiated emissions which fall in the restricted bands, as defined in Section 15.205(a), must also comply with the radiated emission limits specified in Section 15.209(a) (see Section 15.205(c)).

According to Section 15.209(a) , except as provided elsewhere in this Subpart, the emissions from an intentional radiator shall not exceed the field strength levels specified in the following table:

Frequency (MHz)	Field strength (microvolts/meter)	Field strength (dB μ V/m)	Measurement distance (meters)
30-88	100**	$20 \cdot \log(100) = 40.0$	3
88-216	150**	$20 \cdot \log(150) = 43.5$	3
216-960	200	$20 \cdot \log(200) = 46.0$	3
960-2500	500	$20 \cdot \log(500) = 54.0$	3

** Except as provided in paragraph(g), fundamental emissions from intentional radiators operating under this Section shall not be located in the frequency bands 54-72Mhz, 76-88Mhz, 174-216Mhz or 470-806Mhz. However, operation within these frequency bands is permitted under other sections of this Part, e.g., Sections 15.231 and 15.241.

According to section 15.35(b), on any frequency or frequencies above 1000 MHz the radiated limits shown are based upon the use of measurement instrumentation employing an average detector function. When average radiated emission

measurements are specified in this part, including emission measurements below 1000 MHz, there also is a limit on the radio frequency emissions, as measured using instrumentation with a peak detector function, corresponding to 20 dB above the maximum permitted average limit for the frequency being investigated

Test results

Frequency (MHz)	Polarization (H/V)	Corr. Factor (dB)	Result (dBuV/m)		Limit (dBuV/m)		Margin (dB)		Table Angle (Deg.)	Ant. Height (m)
			A	P	A	P	A	P		
Operating frequency : 2402Mhz										
4804	V	16.3	42.0	55.4	54	74	12.0	18.6	210	1.5
4804	H	16.3	42.4	55.4	54	74	11.6	18.6	210	1.6

Frequency (MHz)	Polarization (H/V)	Corr. Factor (dB)	Result (dBuV/m)		Limit (dBuV/m)		Margin (dB)		Table Angle (Deg.)	Ant. Height (m)
			A	P	A	P	A	P		
Operating frequency : 2441Mhz										
4882	V	16.4	41.8	55.0	54	74	12.2	19.0	210	1.5
4882	H	16.4	42.8	55.5	54	74	11.2	18.5	210	1.6

Frequency (MHz)	Polarization (H/V)	Corr. Factor (dB)	Result (dBuV/m)		Limit (dBuV/m)		Margin (dB)		Table Angle (Deg.)	Ant. Height (m)
			A	P	A	P	A	P		
Operating frequency : 2480Mhz										
4960	V	16.4	42.9	56.2	54	74	11.1	17.8	210	1.5
4960	H	16.4	41.5	55.9	54	74	12.5	18.1	210	1.6

Note :

1. Remark “*” means that the emission frequency is produced by local oscillator.
2. Remark “- -” means that the emission level is too low to be measured.
3. The measurement uncertainty of the radiated emission test is $\pm 3\text{dB}$
4. “A” and “P” mean average and peak measurement respectively.
5. There are no spurious emissions found between the lowest internal oscillating frequency and 30 MHz.

8. List of Test and Measurement Instruments

	Kind of Equipment	Type	Manufacturer	S/N
<input checked="" type="checkbox"/>	EMI Test Receiver	ESI26	R/S	8340.0010.02
<input checked="" type="checkbox"/>	Spectrum Analyzer	FSP30	R/S	1093.4495.30
<input type="checkbox"/>	Tracking Generator	ESMI-B1	R/S	1033.3240.52
<input type="checkbox"/>	Spectrum Analyzer	8566B	HP	3638A0857E
<input type="checkbox"/>	Spectrum Analyzer	E4407B	HP	MY41310181
<input type="checkbox"/>	Wave Dipole Antenna	HZ-12	R/S	842006/0012
<input type="checkbox"/>	Wave Dipole Antenna	HZ-12	R/S	846556/0004
<input type="checkbox"/>	Biconical Antenna	3104C	EMCO	9408-4667
<input type="checkbox"/>	Biconical Antenna	3109	EMCO	9405-2812
<input checked="" type="checkbox"/>	Log-Periodic Antenna	3146A	EMCO	1064
<input type="checkbox"/>	Biconilog Antenna	HLP2603	EMC	080100
<input type="checkbox"/>	V-Network	ESH3-Z5	R/S	847265/030
<input type="checkbox"/>	V-Network	ESH3-Z6	R/S	847250/016
<input type="checkbox"/>	T-Network	E-Z10	R/S	84480/011
<input type="checkbox"/>	LISN	3825/2	EMCO	9502-2334
<input checked="" type="checkbox"/>	Turn Table	2081	EMCO	
<input checked="" type="checkbox"/>	Antenna Tower	1072-5	EMCO	9202-1651
<input checked="" type="checkbox"/>	Positioning Controller	1090	EMCO	
<input type="checkbox"/>	Printer	C4569A	HP	SG78K1H1FS
<input type="checkbox"/>	Absorbing Clamp	MDS 21	R/S	847905/005
<input type="checkbox"/>	Signal Generator	2023	MARCONI	112246067
<input type="checkbox"/>	Swept Signal Generator	83620B	HP	3722A00549
<input type="checkbox"/>	10dB Attenuator	23-10-34	Weinschel co	BD4316
<input type="checkbox"/>	10dB Attenuator	33-10-34	Weinschel co	BB9784
<input checked="" type="checkbox"/>	Loop Antenna	6507	EMCO	9408-1327
<input checked="" type="checkbox"/>	Antenna	3142	EMCO	9710-1220
<input checked="" type="checkbox"/>	Antenna	3115	EMCO	9202-3820
<input checked="" type="checkbox"/>	Antenna	3160-08	EMCO	1168
<input checked="" type="checkbox"/>	Antenna	3160-09	EMCO	1304
<input checked="" type="checkbox"/>	Amplifier	HP8447F	HP	3113A06911
<input checked="" type="checkbox"/>	Amplifier	HP83006	HP	3104A00611

<input checked="" type="checkbox"/>	Amplifier	HP8449B	HP	3008A00859
<input type="checkbox"/>	EMI test receiver	ESCS30	R&S	839809/003
<input type="checkbox"/>	Artificial mains network	ESH2-Z5	R&S	829991/009
<input type="checkbox"/>	Artificial hand	FCC-AH-1	Fischer custom communications Inc.	2008

9. Notes

N/A