



SAR TEST REPORT

HCT CO., LTD



EUT Type:	Cellular/PCS GSM Phone with Bluetooth GPRS Class 10 and GPRS mode class B(GPRS and GSM, but not simultaneously)		
FCC ID:	BEJGX200		
Model:	GX200	Trade Name	LG
Date of Issue:	Dec.07, 2009		
Test report No.:	HCTA0912FS02		
Test Laboratory:	HCT CO., LTD. SAN 136-1, AMI-RI, BUBAL-EUP, ICHEON-SI, KYOUNGKI-DO, 467-701, KOREA TEL: +82 31 639 8565 FAX: +82 31 639 8525		
Applicant :	LG Electronics, Inc. 60-39, Gasan-Dong, Gumchon-Gu, Seoul 153-023, Korea Tel: +82-2-2033-1113 Fax: +82-2-2033-1222		
Testing has been carried out in accordance with:	47CFR §2.1093 FCC OET Bulletin 65(Edition 97-01), Supplement C (Edition 01-01) ANSI/ IEEE C95.1 – 2005 IEEE 1528-2003		
Test result:	The tested device complies with the requirements in respect of all parameters subject to the test. The test results and statements relate only to the items tested. The test report shall not be reproduced except in full, without written approval of the laboratory.		
Signature	 _____ Report prepared by : Sun-Hee Kim Test Engineer of SAR Part	 _____ Approved by : Jae-Sang So Manager of SAR Part	

Table of Contents

1. INTRODUCTION	3
2. DESCRIPTION OF DEVICE	4
3. DESCRIPTION OF TEST EQUIPMENT	5
3.1 SAR MEASUREMENT SETUP	5
3.2 DASY E-FIELD PROBE SYSTEM	6
3.3 PROBE CALIBRATION PROCESS	7
3.4 SAM Phantom	9
3.5 Device Holder for Transmitters	9
3.6 Brain & Muscle Simulating Mixture Characterization	10
3.7 SAR TEST EQUIPMENT	11
4. SAR MEASUREMENT PROCEDURE	12
5. DESCRIPTION OF TEST POSITION	13
5.1 HEAD POSITION	13
5.2 Body Holster/Belt Clip Configurations	14
6. MEASUREMENT UNCERTAINTY	15
7. ANSI/ IEEE C95.1 - 2005 RF EXPOSURE LIMITS	16
8. SYSTEM VERIFICATION	17
8.1 Tissue Verification	17
8.2 System Validation	17
9. RF CONDUCTED POWER	18
9.1 Procedures Used to Establish RF Signal for SAR	18
10. SAR Evaluation Considerations for Handsets with Multiple Transmitters and Antennas	19
11. SAR TEST DATA SUMMARY	20
11.1 Measurement Results (GSM850 Head SAR Touch SIM I)	20
11.2 Measurement Results (GSM850 Head SAR Touch SIM II)	21
11.3 Measurement Results (GSM850 Head SAR Tilt SIM I)	22
11.4 Measurement Results (GSM850 Head SAR Tilt SIM II)	23
11.5 Measurement Results (GSM1900 Head SAR Touch SIM I)	24
11.6 Measurement Results (GSM1900 Head SAR Touch SIM II)	25
11.7 Measurement Results (GSM1900 Head SAR Tilt SIM I)	26
11.8 Measurement Results (GSM1900 Head SAR Tilt SIM II)	27
11.9 Measurement Results (GSM850 Body SAR SIM I)	28
11.10 Measurement Results (GSM850 Body SAR SIM II)	29
11.11 Measurement Results (GSM1900 Body SAR SIM I)	30
11.12 Measurement Results (GSM1900 Body SAR SIM II)	31
12. CONCLUSION	32
13. REFERENCES	33
Attachment 1. – SAR Test Plots	34
Attachment 2. – Dipole Validation Plots	87
Attachment 3. – Probe Calibration Data	94
Attachment 4. – Dipole Calibration Data	104

1. INTRODUCTION

The FCC has adopted the guidelines for evaluating the environmental effects of radio frequency radiation in ET Docket 93-62 on Aug. 6, 1996 to protect the public and workers from the potential hazards of RF emissions due to FCC-regulated portable devices.

The safety limits used for the environmental evaluation measurements are based on the criteria published by the American National Standards Institute (ANSI) for localized specific absorption rate (SAR) in IEEE/ANSI C95.1-2005 Standard for Safety Levels with Respect to Human Exposure to Radio Frequency Electromagnetic Fields, 3 kHz to 300 GHz. 1992 by the Institute of Electrical and Electronics Engineers, Inc., New York, New York 10017. The measurement procedure described in IEEE/ANSI C95.3-1992 Recommended Practice for the Measurement of Potentially Hazardous Electromagnetic Fields - RF and Microwave is used for guidance in measuring SAR due to the RF radiation exposure from the Equipment Under Test (EUT). These criteria for SAR evaluation are similar to those recommended by the National Council on Radiation Protection and Measurements (NCRP) in Biological Effects and Exposure Criteria for Radio frequency Electromagnetic Fields," NCRP Report No. 86 NCRP, 1986, Bethesda, MD 20814. SAR is a measure of the rate of energy absorption due to exposure to an RF transmitting source. SAR values have been related to threshold levels for potential biological hazards.

SAR Definition

Specific Absorption Rate (SAR) is defined as the time derivative of the incremental electromagnetic energy (dW) absorbed by (dissipated in) an incremental mass (dm) contained in a volume element (dV) of a given density (ρ). It is also defined as the rate of RF energy absorption per unit mass at a point in an absorbing body.

$$SAR = \frac{d}{dt} \left(\frac{dU}{dm} \right) = \frac{d}{dt} \left(\frac{dU}{\rho dV} \right)$$

Figure 2. SAR Mathematical Equation

SAR is expressed in units of Watts per Kilogram (W/kg).

where:

$$SAR = \sigma E^2 / \rho$$

σ = conductivity of the tissue-simulant material (S/m)
 ρ = mass density of the tissue-simulant material (kg/m³)
 E = Total RMS electric field strength (V/m)

NOTE: The primary factors that control rate of energy absorption were found to be the wavelength of the incident field in relations to the dimensions and geometry of the irradiated organism, the orientation of the organism in relation to the polarity of field vectors, the presence of reflecting surfaces, and whether conductive contact is made by the organism with a ground plane.

2. DESCRIPTION OF DEVICE

Environmental evaluation measurements of specific absorption rate (SAR) distributions in emulated human head and body tissues exposed to radio frequency (RF) radiation from wireless portable devices for compliance with the rules and regulations of the U.S. Federal Communications Commission (FCC).

EUT Type	Cellular/PCS GSM Phone with Bluetooth GPRS Class 10 and GPRS mode class B(GPRS and GSM, but not simultaneously)
FCC ID	BEJGX200
Model(s)	GX200
Trade Name	LG
Serial Number(s)	#1
Application Type	Certification
Modulation(s)	GSM850/GSM1900
Tx Frequency	824.20 - 848.80 MHz (GSM850) 1 850.20 – 1 909.80 MHz (GSM1900)
Rx Frequency	869.20 - 893.80 MHz (GSM850) 1 930.20 – 1 989.80 MHz (GSM1900)
FCC Classification	Licensed Portable Transmitter Held to Ear (PCE)
Production Unit or Identical Prototype	Prototype
Max SAR	SIMI; 1.18 W/kg GSM850 / 1.09 W/kg GSM850 Body SAR 0.948 W/kg GSM1900 Head SAR / 0.343 W/kg GSM1900 Body SAR SIM II; 1.27 W/kg GSM850 / 0.994 W/kg GSM850 Body SAR 0.949 W/kg GSM1900 Head SAR / 0.376 W/kg GSM1900 Body SAR
Date(s) of Tests	Dec. 2, 2009 ~ Dec. 3, 2009
Antenna Type	Intenna

3. DESCRIPTION OF TEST EQUIPMENT

3.1 SAR MEASUREMENT SETUP

These measurements are performed using the DASY4 automated dosimetric assessment system. It is made by Schmid & Partner Engineering AG (SPEAG) in Zurich, Switzerland. It consists of high precision robotics system (Staubli), robot controller, Pentium III computer, near-field probe, probe alignment sensor, and the generic twin phantom containing the brain equivalent material. The robot is a six-axis industrial robot performing precise movements to position the probe to the location (points) of maximum electromagnetic field (EMF) (see Figure.3.1).

A cell controller system contains the power supply, robot controller, teach pendant (Joystick), and remote control, is used to drive the robot motors. The PC consists of the HP Pentium IV 3.0 GHz computer with Windows XP system and SAR Measurement Software DASY4, A/D interface card, monitor, mouse, and keyboard. The Staubli Robot is connected to the cell controller to allow software manipulation of the robot. A data acquisition electronic (DAE) circuit performs the signal amplification, signal multiplexing, AD-conversion, offset measurements, mechanical surface detection, collision detection, etc. is connected to the Electro-optical coupler (EOC). The EOC performs the conversion from the optical into digital electric signal of the DAE and transfers data to the PC plug-in card.

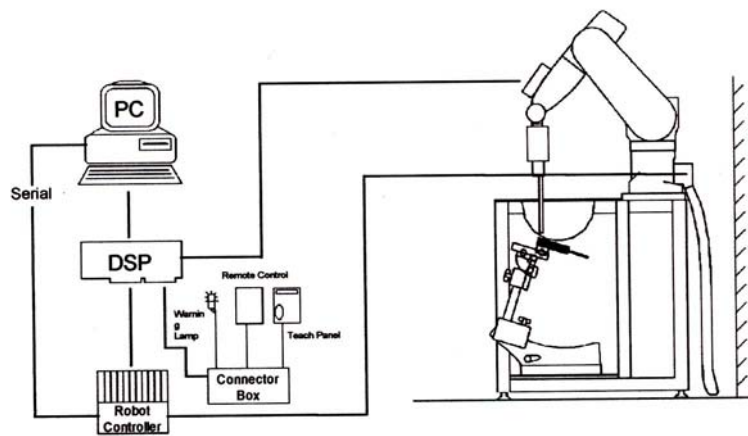

Figure 3.1 HCT SAR Lab. Test Measurement Set-up

The DAE4 consists of a highly sensitive electrometer-grade preamplifier with auto-zeroing, a channel and gain-switching multiplexer, a fast 16 bit AD-converter and a command decoder and control logic unit. Transmission to the PC-card is accomplished through an optical downlink for data and status information and an optical uplink for commands and clock lines. The mechanical probe mounting device includes two different sensor systems for frontal and sidewise probe contacts. They are also used for mechanical surface detection and probe collision detection. The robot uses its own controller with a built in VME-bus computer. The system is described in detail in.

3.2 DASY E-FIELD PROBE SYSTEM

3.2.1 ET3DV6 Probe Specification

Construction	Symmetrical design with triangular core Built-in optical fiber for surface detection System Built-in shielding against static charges
Calibration	In air from 10 MHz to 2.5 GHz In brain and muscle simulating tissue at Frequencies of 450 MHz, 900 MHz and 1.8 GHz (accuracy: 8 %)
Frequency	10 MHz to > 6 GHz; Linearity: ± 0.2 dB (30 MHz to 3 GHz)
Directivity	± 0.2 dB in brain tissue (rotation around probe axis) ± 0.4 dB in brain tissue (rotation normal probe axis)
Dynamic	5 μ W/g to > 100 mW/g;
Range Linearity:	± 0.2 dB
Surface Detection	± 0.2 mm repeatability in air and clear liquids over diffuse reflecting surfaces.
Dimensions	Overall length: 330 mm Tip length: 16 mm Body diameter: 12 mm Tip diameter: 6.8 mm Distance from probe tip to dipole centers: 2.7 mm
Application	General dissymmetry up to 3 GHz Compliance tests of mobile phones Fast automatic scanning in arbitrary phantoms



Figure 3.2 Photograph of the probe and the Phantom

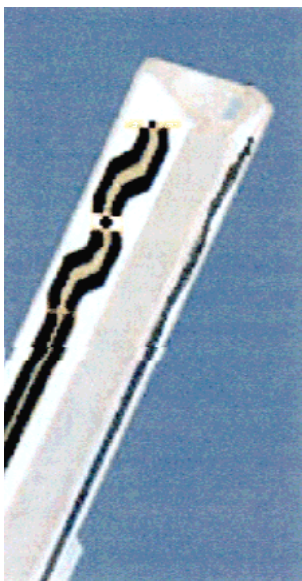

Figure 3.3 ET3DV6 E-field Probe

The SAR measurements were conducted with the dosimetric probe ET3DV6, designed in the classical triangular configuration and optimized for dosimetric evaluation. The probe is constructed using the thick film technique; with printed resistive lines on ceramic substrates. The probe is equipped with an optical multifiber line ending at the front of the probe tip. It is connected to the EOC box on the robot arm and provides an automatic detection of the phantom surface. Half of the fibers are connected to a pulsed infrared transmitter, the other half to a synchronized receiver. As the probe approaches the surface, the reflection from the surface produces a coupling from the transmitting to the receiving fibers. This reflection increases first during the approach, reaches a maximum and then decreases. If the probe is flatly touching the surface, the coupling is zero. The distance of the coupling maximum to the surface is independent of the surface reflectivity and largely independent of the surface to probe angle. The DASY4 software reads the reflection during a software approach and looks for the maximum using a 2nd order fitting. The approach is stopped at reaching the maximum.

3.3 PROBE CALIBRATION PROCESS

3.3.1 E-Probe Calibration

Each probe is calibrated according to a dosimetric assessment procedure with an accuracy better than ± 10 %. The spherical isotropy was evaluated with the proper procedure and found to be better than ± 0.25 dB. The sensitivity parameters (NormX, NormY, NormZ), the diode compression parameter (DCP) and the conversion factor (ConvF) of the probe is tested.

The free space E-field from amplified probe outputs is determined in a test chamber. This is performed in a TEM cell for frequencies bellow 1 GHz, and in a waveguide above 1 GHz for free space. For the free space calibration, the probe is placed in the volumetric center of the cavity and at the proper orientation with the field. The probe is then rotated 360 degrees.

E-field temperature correlation calibration is performed in a flat phantom filled with the appropriate simulated brain tissue. The measured free space E-field in the medium correlates to temperature rise in a dielectric medium. For temperature correlation calibration a RF transparent thermistor-based temperature probe is used in conjunction with the E-field probe.

$$SAR = C \frac{\Delta T}{\Delta t}$$

where:

- Δt = exposure time (30 seconds),
- C = heat capacity of tissue (brain or muscle),
- ΔT = temperature increase due to RF exposure.

SAR is proportional to $\Delta T / \Delta t$, the initial rate of tissue heating, before thermal diffusion takes place. Now it's possible to quantify the electric field in the simulated tissue by equating the thermally derived SAR to the E- field;

$$SAR = \frac{|E|^2 \cdot \sigma}{\rho}$$

where:

- σ = simulated tissue conductivity,
- ρ = Tissue density (1.25 g/cm³ for brain tissue)

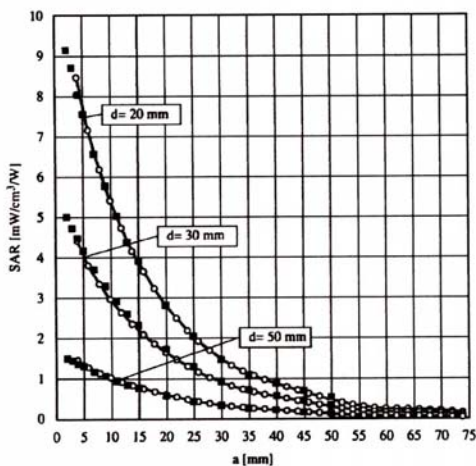

Figure 3.4 E-Field and Temperature measurements at 900 MHz

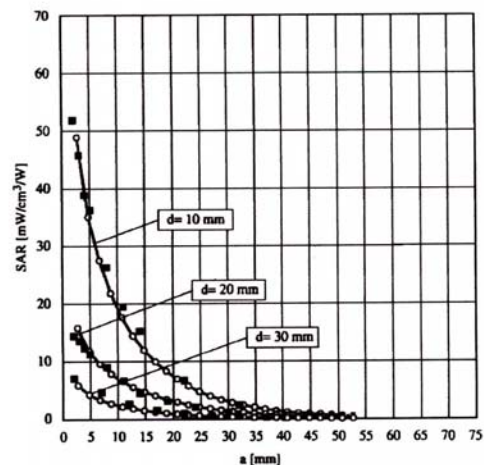

Figure 3.5 E-Field and temperature measurements at 1.8 GHz

3.3.2 Data Extrapolation

The DASY4 software automatically executes the following procedures to calculate the field units from the microvolt readings at the probe connector. The first step of the evaluation is a linearization of the filtered input signal to account for the compression characteristics of the detector diode. The compensation depends on the input signal, the diode type and the DC-transmission factor from the diode to the evaluation electronics. If the exciting field is pulsed, the crest factor of the signal must be known to correctly compensate for peak power. The formula for each channel can be given like below;

$$V_i = U_i + U_i^2 \cdot \frac{cf}{dcp_i}$$

with V_i = compensated signal of channel i (i=x,y,z)
 U_i = input signal of channel i (i=x,y,z)
 cf = crest factor of exciting field (DASY parameter)
 dcp_i = diode compression point (DASY parameter)

From the compensated input signals the primary field data for each channel can be evaluated:

E-field probes:

$$E_i = \sqrt{\frac{V_i}{Norm_i \cdot ConvF}}$$

with V_i = compensated signal of channel i (i = x,y,z)
 $Norm_i$ = sensor sensitivity of channel i (i = x,y,z)
 $\mu V/(V/m)^2$ for E-field probes
 $ConvF$ = sensitivity of enhancement in solution
 E_i = electric field strength of channel i in V/m

The RSS value of the field components gives the total field strength (Hermetian magnitude):

$$E_{tot} = \sqrt{E_x^2 + E_y^2 + E_z^2}$$

The primary field data are used to calculate the derived field units.

$$SAR = E_{tot}^2 \cdot \frac{\sigma}{\rho \cdot 1000}$$

with SAR = local specific absorption rate in W/g
 E_{tot} = total field strength in V/m
 σ = conductivity in [mho/m] or [Siemens/m]
 ρ = equivalent tissue density in g/cm³

The power flow density is calculated assuming the excitation field to be a free space field.

$$P_{pwe} = \frac{E_{tot}^2}{3770}$$

with P_{pwe} = equivalent power density of a plane wave in W/cm²
 E_{tot} = total electric field strength in V/m

3.4 SAM Phantom

The SAM Phantom is constructed of a fiberglass shell integrated in a wooden table. The shape of the shell is based on data from an anatomical study designed to determine the maximum exposure in at least 90 % of all users. It enables the dosimetric evaluation of left and right hand phone usage as well as body mounted usage at the flat phantom region. A cover prevents the evaporation of the liquid. Reference markings on the Phantom allow the complete setup of all predefined phantom positions and measurement grids by manually teaching three points in the robot.

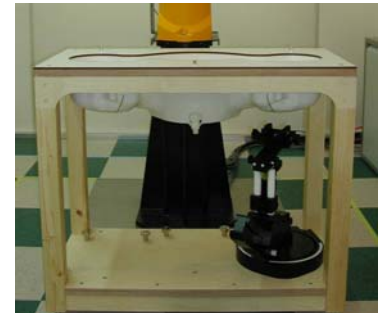

Figure 3.6 SAM Phantom

Shell Thickness	2.0 mm
Filling Volume	about 30 L
Dimensions	810 mm x 1 000 mm x 500 mm (H x L x W)

3.5 Device Holder for Transmitters

In combination with the SAM Phantom V 4.0, the Mounting Device (POM) enables the rotation of the mounted transmitter in spherical coordinates whereby the rotation points is the ear opening. The devices can be easily, accurately, and repeatably positioned according to the FCC and CENELEC specifications. The device holder can be locked at different phantom locations (left head, right head, flat phantom).

Note: A simulating human hand is not used due to the complex anatomical and geometrical structure of the hand that may produce an infinite number of configurations. To produce the Worst-case condition (the hand absorbs antenna output power), the hand is omitted during the tests.



Figure 3.7 Device Holder

3.6 Brain & Muscle Simulating Mixture Characterization

The brain and muscle mixtures consist of a viscous gel using hydrox-ethyl cellulose (HEC) gelling agent and saline solution (see Table 3.1). Preservation with a bactericide is added and visual inspection is made to make sure air bubbles are not trapped during the mixing process. The mixture is calibrated to obtain proper dielectric constant (permittivity) and conductivity of the desired tissue. The mixture characterizations used for the brain and muscle tissue simulating liquids are according to the data by C. Gabriel and G. Hartsgrove.

Ingredients (% by weight)	Frequency (MHz)									
	450		835		915		1 900		2 450	
Tissue Type	Head	Body	Head	Body	Head	Body	Head	Body	Head	Body
Water	38.56	51.16	41.45	52.4	41.05	56.0	54.9	40.4	62.7	73.2
Salt (NaCl)	3.95	1.49	1.45	1.4	1.35	0.76	0.18	0.5	0.5	0.04
Sugar	56.32	46.78	56.0	45.0	56.5	41.76	0.0	58.0	0.0	0.0
HEC	0.98	0.52	1.0	1.0	1.0	1.21	0.0	1.0	0.0	0.0
Bactericide	0.19	0.05	0.1	0.1	0.1	0.27	0.0	0.1	0.0	0.0
Triton X-100	0.0	0.0	0.0	0.0	0.0	0.0	0.0	0.0	36.8	0.0
DGBE	0.0	0.0	0.0	0.0	0.0	0.0	44.92	0.0	0.0	26.7

Salt:	99 % Pure Sodium Chloride	Sugar:	98 % Pure Sucrose
Water:	De-ionized, 16M resistivity	HEC:	Hydroxyethyl Cellulose
DGBE:	99 % Di(ethylene glycol) butyl ether,[2-(2-butoxyethoxy) ethanol]		
Triton X-100(ultra pure):	Polyethylene glycol mono[4-(1,1,3,3-tetramethylbutyl)phenyl] ether		

Table 3.1 Composition of the Tissue Equivalent Matter

3.7 SAR TEST EQUIPMENT

Manufacturer	Type / Model	S/N	Calib. Date	Calib.Interval	Calib.Due
SPEAG	SAM Phantom	-	N/A	N/A	N/A
Staubli	Robot RX90L	F01/5K09A1/A/01	N/A	N/A	N/A
Staubli	Robot ControllerCS7MB	F99/5A82A1/C/01	N/A	N/A	N/A
HP	Pavilion t000_puffer	KRJ51201TV	N/A	N/A	N/A
SPEAG	Light Alignment Sensor	265	N/A	N/A	N/A
Staubli	Teach Pendant (Joystick)	D221340.01	N/A	N/A	N/A
SPEAG	DAE3	446	May 22, 2009	Annual	May 22, 2010
SPEAG	DAE3	466	July 21, 2009	Annual	July 21, 2010
SPEAG	E-Field Probe ET3DV6	1631	Jun. 24, 2009	Annual	Jun. 24, 2010
SPEAG	E-Field Probe ET3DV6	1609	Mar. 17, 2009	Annual	Mar. 17, 2010
SPEAG	E-Field Probe ES3DV6	3161	July 22, 2009	Annual	July 22, 2010
SPEAG	Validation Dipole D450V2	1007	July 15, 2008	Biennial	July 15, 2010
SPEAG	Validation Dipole D835V2	441	May 25, 2009	Annual	May 25, 2010
SPEAG	Validation Dipole D1800V2	2d007	May 20, 2008	Biennial	May 20, 2010
SPEAG	Validation Dipole D1900V2	5d032	July 20, 2009	Annual	July 20, 2010
SPEAG	Validation Dipole D2450V2	743	Aug. 27, 2008	Biennial	Aug. 27, 2010
Agilent	Power Meter(F) E4419B	MY41291386	Nov. 05, 2009	Annual	Nov. 05, 2010
Agilent	Power Sensor(G) 8481	MY41090870	Nov. 05, 2009	Annual	Nov. 05, 2010
HP	Dielectric Probe Kit 85070C	00721521	N/A	N/A	N/A
HP	Dual Directional Coupler	16072	Nov. 05, 2010	Annual	Nov. 05, 2010
R&S	Base Station CMU200	110740	July 26, 2009	Annual	July 26, 2010
Agilent	Base Station E5515C	GB44400269	Feb. 10, 2009	Annual	Feb. 10, 2010
HP	Signal Generator E4438C	MY42082646	Dec. 24, 2008	Annual	Dec. 24, 2009
HP	Network Analyzer 8753C	3310J01394	Dec. 04, 2008	Annual	Dec. 04, 2009
Tescom	TC-3000/ Bluetooth	3000A490112	Jan. 09, 2009	Annual	Jan. 09, 2010

NOTE:

The E-field probe was calibrated by SPEAG, by the waveguide technique procedure. Dipole Validation measurement is performed by HCT Lab. before each test. The brain simulating material is calibrated by HCT using the dielectric probe system and network analyzer to determine the conductivity and permittivity (dielectric constant) of the brain-equivalent material.

4. SAR MEASUREMENT PROCEDURE

The evaluation was performed with the following procedure:

1. The SAR value at a fixed location above the ear point was measured and was used as a reference value for assessing the power drop.
2. The SAR distribution at the exposed side of the head was measured at a distance of 3.9 mm from the inner surface of the shell. The area covered the entire dimension of the head and the horizontal grid spacing was 20 mm x 20 mm. Based on this data, the area of the maximum absorption was determined by spline interpolation.
3. Around this point, a volume of 32 mm x 32 mm x 30 mm was assessed by measuring 5 x 5 x 7 points. On this basis of this data set, the spatial peak SAR value was evaluated with the following procedure:
 - a. The data at the surface were extrapolated, since the center of the dipoles is 2.7 mm away from the tip of the probe and the distance between the surface and the lowest measuring point is 1.2 mm. The extrapolation was based on a least square algorithm. A polynomial of the fourth order was calculated through the points in z-axes. This polynomial was then used to evaluate the points between the surface and the probe tip.
 - b. The maximum interpolated value was searched with a straight-forward algorithm. Around this maximum the SAR values averaged over the spatial volumes (1 g or 10 g) were computed using the 3D-Spline interpolation algorithm. The 3D-spline is composed of three one-dimensional splines with the "Not a knot" condition (in x, y, and z directions. The volume was integrated with the trapezoidal algorithm. One thousand points (10 x 10 x 10) were interpolated to calculate the average.
 - c. All neighboring volumes were evaluated until no neighboring volume with a higher average value was found.
4. The SAR value, at the same location as procedure #1, was re-measured. If the value changed by more than 5 %, the evaluation is repeated.

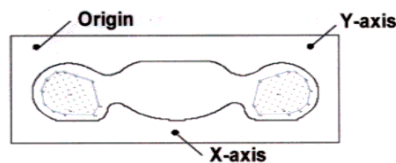

Figure 4.1 SAR Measurement Point in Area Scan

5. DESCRIPTION OF TEST POSITION

5.1 HEAD POSITION

The device was placed in a normal operating position with the Point A on the device, as illustrated in following drawing, aligned with the location of the RE(ERP) on the phantom. With the ear-piece pressed against the head, the vertical center line of the body of the handset was aligned with an imaginary plane consisting of the RE, LE and M. While maintaining these alignments, the body of the handset was gradually moved towards the cheek until any point on the mouth-piece or keypad contacted the cheek. This is a cheek/touch position. For ear/tilt position, while maintain the device aligned with the BM and FN lines, the device was pivot against ERP back for 15° or until the device antenna touch the phantom. Please refer to IEEE 1528-2003 illustration below.

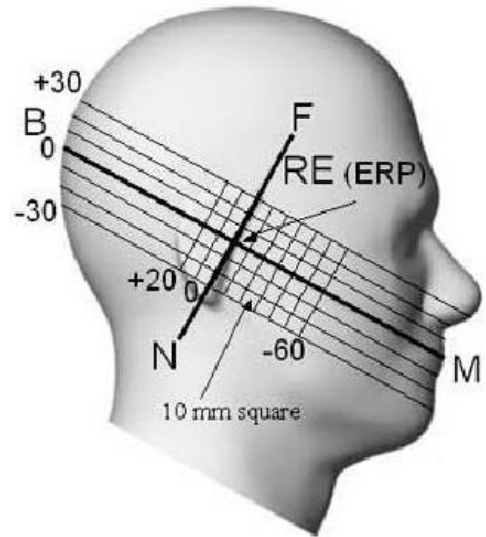

Figure 5.1 Side view of the phantom

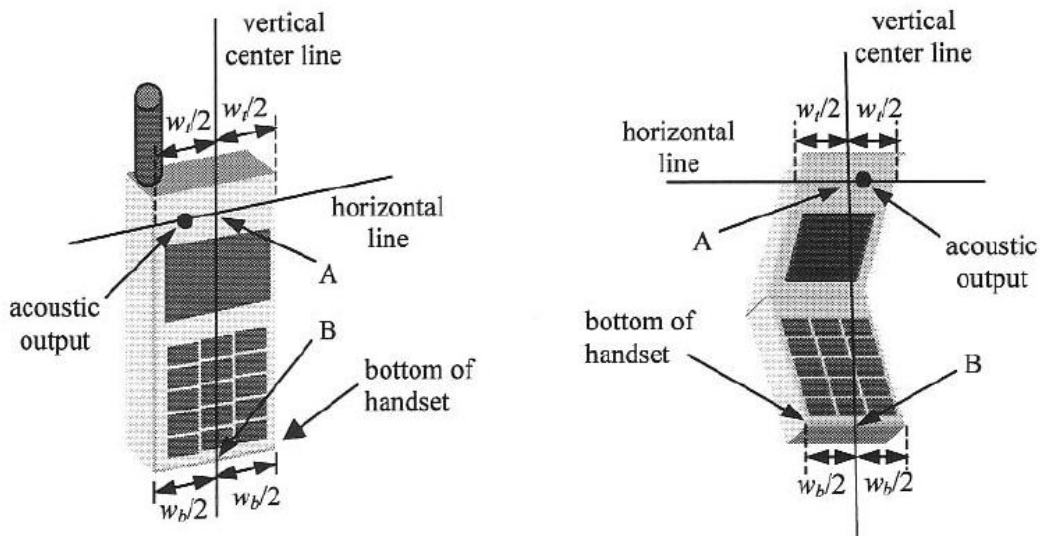

Figure 5.2 Handset vertical and horizontal reference lines

5.2 Body Holster/Belt Clip Configurations

Body-worn operating configurations are tested with the belt-clips and holsters attached to the device and positioned against a flat phantom in a normal use configuration. A device with a headset output is tested with a headset connected to the device. Body dielectric parameters are used.

Accessories for Body-worn operation configurations are divided into two categories: those that do not contain metallic components and those that contain metallic components. When multiple accessories that do not contain metallic components are supplied with the device, the device is tested with only the accessory that dictates the closest spacing to the body. Then multiple accessories that contain metallic components are tested with each accessory. If multiple accessory share an identical metallic component (i.e. the same metallic belt-clip used with different holsters with no other metallic components) only the accessory that dictates the closest spacing to the body is tested.

Body-worn accessories may not always be supplied or available as options for some Devices intended to be authorized for body-worn use. In this case, a test configuration with a separation distance between the back of the device and the flat phantom is used.

Since this EUT does not supply any body worn accessory to the end user a distance of 2.0 cm from the EUT back surface to the liquid interface is configured for the generic test.

"See the Test SET-UP Photo"

Transmitters that are designed to operate in front of a person's face, as in push-to-talk configurations, are tested for SAR compliance with the front of the device positioned to face the flat phantom. For devices that are carried next to the body such as a shoulder, waist or chest-worn transmitters, SAR compliance is tested with the accessory(ies), including headsets and microphones, attached to the device and positioned against a flat phantom in a normal use configuration.

In all cases SAR measurements are performed to investigate the worst-case positioning. Worstcase positioning is then documented and used to perform Body SAR testing.

6. MEASUREMENT UNCERTAINTY

Measurement uncertainties in SAR measurements are difficult to quantify due to several variables including biological, physiological, and environmental. However, we estimate the measurement uncertainties in SAR to be less than 15 % - 25 %.

According to ANSI/IEEE C95.3, the overall uncertainties are difficult to assess and will vary with the type of meter and usage situation. However, accuracy's of 1 dB to ± 3 dB can be expected in practice, with greater uncertainties in near-field situations and at higher frequencies (shorter wavelengths), or areas where large reflecting objects are present. Under optimum measurement conditions, SAR measurement uncertainties of at least ± 2 dB can be expected.

According to CENELEC, typical worst-case uncertainty of field measurements is 5 dB. For well-defined modulation characteristics the uncertainty can be reduced to ± 3 dB.

Error Description	Uncertainty value [%]	Probability Distribution	Divisor	ci	ci ²	Standard Uncertainty [%]	Stand Uncert ²	(Stand Uncert ²) X (ci ²)	Vi & Veff
1. Measurement System									
Probe Calibration	5.5	Normal	1.00	1	1	5.50	30.25	30.25	∞
Axial Isotropy	4.7	Rectangular	1.73	0.7	0.49	2.71	7.36	3.61	∞
Hemispherical Isotropy	9.6	Rectangular	1.73	0.7	0.49	5.54	30.72	15.05	∞
Linearity	4.7	Rectangular	1.73	1	1	2.71	7.36	7.36	∞
System Detection limits	1.0	Rectangular	1.73	1	1	0.58	0.33	0.33	∞
Boundary effect	1.0	Rectangular	1.73	1	1	0.58	0.33	0.33	∞
Response time	0.8	Rectangular	1.73	1	1	0.46	0.21	0.21	∞
RF Ambient conditions	3.0	Rectangular	1.73	1	1	1.73	3.00	3.00	∞
Readout Electronics	0.3	Normal	1.00	1	1	0.30	0.09	0.09	∞
Integration time	2.6	Rectangular	1.73	1	1	1.50	2.25	2.25	∞
Probe positioner	0.4	Rectangular	1.73	1	1	0.23	0.05	0.05	∞
Probe positioning	2.9	Rectangular	1.73	1	1	1.67	2.80	2.80	∞
Maximum SAR evaluation	1.0	Rectangular	1.73	1	1	0.58	0.33	0.33	∞
Sub Total								65.69	
2. Test Sample Related									
Device Positioning	1.8	Normal	1.00	1	1	1.81	3.28	3.28	9
Device Holder	3.6	Normal	1.00	1	1	3.60	12.96	12.96	∞
Power Drift	5.0	Rectangular	1.73	1	1	2.89	8.33	8.33	∞
Sub Total								24.57	
3. Phantom and Setup									
Phantom Uncertainty	4.0	Rectangular	1.73	1	1	2.31	5.33	5.33	∞
Liquid conductivity (target)	5.0	Rectangular	1.73	0.5	0.25	2.89	8.33	2.08	∞
Liquid conductivity (measurement error)	2.5	Normal	1.00	0.5	0.25	2.50	6.25	1.56	∞
Liquid permittivity (target)	5.0	Rectangular	1.73	0.5	0.25	2.89	8.33	2.08	∞
Liquid permittivity (measurement error)	2.5	Normal	1.00	0.5	0.25	2.50	6.25	1.56	∞
Sub Total								12.63	
Combined standard uncertainty [%]						10.14		102.88	-
Expanded uncertainty [k=2, approximately confidence level 95 %]						± 20.28 %			

Table 6.1 Breakdown of Errors

7. ANSI/ IEEE C95.1 - 2005 RF EXPOSURE LIMITS

HUMAN EXPOSURE	UNCONTROLLED ENVIRONMENT General Population (W/kg) or (mW/g)	CONTROLLED ENVIRONMENT Occupational (W/kg) or (mW/g)
SPATIAL PEAK SAR * (Brain)	1.60	8.00
SPATIAL AVERAGE SAR ** (Whole Body)	0.08	0.40
SPATIAL PEAK SAR *** (Hands / Feet / Ankle / Wrist)	4.00	20.00

Table 7.1 Safety Limits for Partial Body Exposure

NOTES:

* The Spatial Peak value of the SAR averaged over any 1 g of tissue (defined as a tissue volume in the shape of a cube) and over the appropriate averaging time.

** The Spatial Average value of the SAR averaged over the whole-body.

*** The Spatial Peak value of the SAR averaged over any 10 g of tissue (defined as a tissue volume in the shape of a cube) and over the appropriate averaging time.

Uncontrolled Environments are defined as locations where there is the exposure of individuals who have no knowledge or control of their exposure.

Controlled Environments are defined as locations where there is exposure that may be incurred by persons who are aware of the potential for exposure, (i.e.as a result of employment or occupation).

8. SYSTEM VERIFICATION

8.1 Tissue Verification

Freq. [MHz]	Date	Liquid	Liquid Temp.[°C]	Parameters	Target Value	Measured Value	Deviation [%]	Limit [%]
835	Dec. 2, 2009	Head	21.3	ϵ_r	41.5	42.1	+ 1.45	± 5
				σ	0.90	0.897	- 0.33	± 5
835	Dec. 2, 2009	Body	21.3	ϵ_r	55.2	54.9	- 0.54	± 5
				σ	0.97	0.94	- 3.09	± 5
1 900	Dec. 3, 2009	Head	21.2	ϵ_r	40.0	39.4	- 1.50	± 5
				σ	1.40	1.42	+ 1.43	± 5
1 900	Dec. 3, 2009	Body	21.2	ϵ_r	53.3	53.47	+ 0.32	± 5
				σ	1.52	1.49	- 1.97	± 5

8.2 System Validation

Prior to assessment, the system is verified to the $\pm 10\%$ of the specifications at 835 MHz / 1 900 MHz by using the system validation kit. (Graphic Plots Attached)

* Input Power: 100 m W

Freq. [MHz]	Date	Liquid	Liquid Temp. [°C]	SAR Average	Target Value (SPEAG) (mW/g)	* Measured Value (mW/g)	Deviation [%]	Limit [%]
835	Dec. 2, 2009	Head	21.3	1 g	9.56	0.974	+ 1.88	± 10
1 900	Dec. 3, 2009	Head	21.2	1 g	40.5	4.06	+ 0.25	± 10

9. RF CONDUCTED POWER

Power measurements were performed using a base station simulator under digital average power

9.1 Procedures Used to Establish RF Signal for SAR

The handset was placed into a simulated call using a base station simulator in a shielded chamber. Such test signals offer a consistent means for testing SAR and are recommended for evaluation SAR[4] SAR measurements were taken with a fully charged battery. In order to verify that the device was tested and maintained at full power, this was configured with the base station simulator. The SAR measurement Software calculates a reference point at the start and end of the test to check for power drifts. If conducted Power deviations of more than 5 % occurred, the tests were repeated.

Band	Channel	Voice	GPRS Data	
		GSM (dBm)	GPRS 1 TX Slot (dBm)	GPRS 2 TX Slot (dBm)
GSM 850	128	32.03	32.01	31.99
	190	31.98	31.96	31.95
	251	31.93	31.92	31.90
GSM 1900	512	29.84	29.80	29.74
	661	29.82	29.79	29.73
	810	29.99	29.98	29.92

Table 9.1 Sim I GSM Conducted output powers

Band	Channel	Voice	GPRS Data	
		GSM (dBm)	GPRS 1 TX Slot (dBm)	GPRS 2 TX Slot (dBm)
GSM 850	128	32.01	32.00	31.98
	190	31.99	31.98	31.94
	251	31.94	31.93	31.92
GSM 1900	512	29.78	29.74	29.71
	661	29.79	29.74	29.72
	810	29.96	29.93	29.91

Table 9.2 Sim II GSM Conducted output powers

10. SAR Evaluation Considerations for Handsets with Multiple Transmitters and Antennas

10.1 SAR Evaluation Considerations

These procedures were followed according to FCC "SAR Evaluation Considerations for Handsets with Multiple Transmitters and Antennas", May 2008. The procedures are applicable to phones with built-in unlicensed transmitters, such as 802.11 a/b/g and Bluetooth devices.

	2.45	5.15 - 5.35	5.47 - 5.85	GHz
P_{Ref}	12	6	5	mW

Device output power should be rounded to the nearest mW to compare with values specified in this

Table. 10.1 Output Power Thresholds for Unlicensed Transmitters

	Individual Transmitter	Simultaneous Transmission
Licensed Transmitters	<u>Routine evaluation required</u>	SAR not required: <u>Unlicensed only</u>
Unlicensed Transmitters	<p><u>When there is no simultaneous transmission –</u></p> <ul style="list-style-type: none"> output ≤ 60/f: SAR not required output > 60/f: stand-alone SAR required <p><u>When there is simultaneous transmission – Stand-alone SAR not required when</u></p> <ul style="list-style-type: none"> output ≤ 2·P_{Ref} and antenna is ≥ 5.0 cm from other antennas output ≤ P_{Ref} and antenna is ≥ 2.5 cm from other antennas output ≤ P_{Ref} and antenna is < 2.5 cm from other antennas, each with either output power ≤ P_{Ref} or 1-g SAR < 1.2 W/kg <p><u>Otherwise stand-alone SAR is required</u></p> <p><u>When stand-alone SAR is required</u></p> <ul style="list-style-type: none"> test SAR on highest output channel for each wireless mode and exposure condition if SAR for highest output channel is > 50% of SAR limit, evaluate all channels according to normal procedures 	<ul style="list-style-type: none"> when stand-alone 1-g SAR is not required and antenna is ≥ 5 cm from other antennas <p><u>Licensed & Unlicensed</u></p> <ul style="list-style-type: none"> when the sum of the 1-g SAR is < 1.6 W/kg for all simultaneous transmitting antennas when SAR to peak location separation ratio of simultaneous transmitting antenna pair is < 0.3 <p>SAR required: <u>Licensed & Unlicensed</u></p> <p>antenna pairs with SAR to peak location separation ratio ≥ 0.3; test is only required for the configuration that results in the highest SAR in stand-alone configuration for each wireless mode and exposure condition</p> <p>Note: simultaneous transmission exposure conditions for head and body can be different for different style phones; therefore, different test requirements may apply</p>
Jaw, Mouth and Nose	<p><u>Flat phantom SAR required</u></p> <ul style="list-style-type: none"> when measurement is required in tight regions of SAM and it is not feasible or the results can be questionable due to probe tilt, calibration, positioning and orientation issues position rectangular and clam-shell phones according to flat phantom procedures and conduct SAR measurements for these specific locations 	When simultaneous transmission SAR testing is required, contact the FCC Laboratory for interim guidance.

Table. 10.2 SAR Evaluation Requirements for Cellphones with Multiple Transmitters

FCC ID: **BEJGX200**

BT Max. RF output power: 1.89 dBm (0.65 mW)

Antenna separation distance between Main and BT: 8.97 cm

Because the conducted output power level of the BT transmitter is less than 2·P_{ref}, and the BT antenna is more than 5.0 cm from the Main antenna, neither simultaneous SAR nor stand-alone BT SAR are required for the EUT.

11. SAR TEST DATA SUMMARY

11.1 Measurement Results (GSM850 Head SAR Touch SIM I)

Frequency		Modulation	Conducted Power (dBm)		Battery	Phantom Position	Antenna Type	SAR(mW/g)
MHz	Channel		Begin	End				
824.2	128 (Low)	GSM850	32.03	32.00	Standard	Left Ear	Intenna	1.01
836.6	190 (Mid)	GSM850	31.98	31.96	Standard	Left Ear	Intenna	1.04
848.8	251 (High)	GSM850	31.93	31.54	Standard	Left Ear	Intenna	0.997
824.2	128 (Low)	GSM850	32.03	31.93	Standard	Right Ear	Intenna	1.18
836.6	190 (Mid)	GSM850	31.98	32.01	Standard	Right Ear	Intenna	1.16
848.8	251 (High)	GSM850	31.93	31.87	Standard	Right Ear	Intenna	0.954
ANSI/ IEEE C95.1 2005 – Safety Limit						Head		
Spatial Peak						1.6 W/kg (mW/g)		
Uncontrolled Exposure/ General Population						<small>Averaged over 1 gram</small>		

NOTES:

- The test data reported are the worst-case SAR value with the antenna-head position set in a typical configuration. Test procedures used are according to FCC/OET Bulletin 65, Supplement C [July 2001].
- All modes of operation were investigated and the worst-case are reported.
- Measured Depth of Simulating Tissue is 15.0 cm ± 0.2 cm.
- Tissue parameters and temperatures are listed on the SAR plot.
- Battery Type Standard Extended Slim
Batteries are fully charged for all readings.
- Test Signal Call Mode Manual Test cord Base Station Simulator

11.2 Measurement Results (GSM850 Head SAR Touch SIM II)

Frequency		Modulation	Conducted Power (dBm)		Battery	Phantom Position	Antenna Type	SAR(mW/g)
MHz	Channel		Begin	End				
824.2	128 (Low)	GSM850	32.01	31.88	Standard	Left Ear	Intenna	1.19
836.6	190 (Mid)	GSM850	31.99	31.85	Standard	Left Ear	Intenna	1.08
848.8	251 (High)	GSM850	34.94	34.88	Standard	Left Ear	Intenna	0.955
824.2	128 (Low)	GSM850	32.01	31.88	Standard	Right Ear	Intenna	1.27
836.6	190 (Mid)	GSM850	31.99	31.91	Standard	Right Ear	Intenna	1.15
848.8	251 (High)	GSM850	34.94	34.83	Standard	Right Ear	Intenna	0.96
ANSI/ IEEE C95.1 2005 – Safety Limit Spatial Peak Uncontrolled Exposure/ General Population						Head 1.6 W/kg (mW/g) Averaged over 1 gram		

NOTES:

- 1 The test data reported are the worst-case SAR value with the antenna-head position set in a typical configuration. Test procedures used are according to FCC/OET Bulletin 65, Supplement C [July 2001].
- 2 All modes of operation were investigated and the worst-case are reported.
- 3 Measured Depth of Simulating Tissue is 15.0 cm ± 0.2 cm.
- 4 Tissue parameters and temperatures are listed on the SAR plot.
- 5 Battery Type Standard Extended Slim
Batteries are fully charged for all readings.
- 6 Test Signal Call Mode Manual Test cord Base Station Simulator

11.3 Measurement Results (GSM850 Head SAR Tilt SIM I)

Frequency		Modulation	Conducted Power (dBm)		Battery	Phantom Position	Antenna Type	SAR(mW/g)
MHz	Channel		Begin	End				
836.6	190 (Mid)	GSM850	31.98	31.95	Standard	Left Tilt 15°	Intenna	0.577
836.6	190 (Mid)	GSM850	31.98	32.10	Standard	Right Tilt 15°	Intenna	0.538
ANSI/ IEEE C95.1 2005 – Safety Limit						Head		
Spatial Peak						1.6 W/kg (mW/g)		
Uncontrolled Exposure/ General Population						Averaged over 1 gram		

NOTES:

- The test data reported are the worst-case SAR value with the antenna-head position set in a typical configuration. Test procedures used are according to FCC/OET Bulletin 65, Supplement C [July 2001].
- All modes of operation were investigated and the worst-case are reported.
- Measured Depth of Simulating Tissue is 15.0 cm ± 0.2 cm.
- Tissue parameters and temperatures are listed on the SAR plot.
- Battery Type Standard Extended Slim
Batteries are fully charged for all readings.
- Test Signal Call Mode Manual Test cord Base Station Simulator
- Justification for reduced test configurations: per FCC/OET Supplement C (July, 2001), if the SAR measured at the middle channel for each test configuration (Left, right, cheek/touch, tilt/ear, extended and retracted) is at least 3.0 dB lower than the SAR limit, testing at the high and low channels is optional for such test configuration(s).

11.4 Measurement Results (GSM850 Head SAR Tilt SIM II)

Frequency		Modulation	Conducted Power (dBm)		Battery	Phantom Position	Antenna Type	SAR(mW/g)
MHz	Channel		Begin	End				
836.6	190 (Mid)	GSM850	31.99	31.92	Standard	Left Tilt 15°	Intenna	0.582
836.6	190 (Mid)	GSM850	31.99	31.90	Standard	Right Tilt 15°	Intenna	0.543
ANSI/ IEEE C95.1 2005 – Safety Limit						Head		
Spatial Peak						1.6 W/kg (mW/g)		
Uncontrolled Exposure/ General Population						<small>Averaged over 1 gram</small>		

NOTES:

- 1 The test data reported are the worst-case SAR value with the antenna-head position set in a typical configuration. Test procedures used are according to FCC/OET Bulletin 65, Supplement C [July 2001].
- 2 All modes of operation were investigated and the worst-case are reported.
- 3 Measured Depth of Simulating Tissue is 15.0 cm ± 0.2 cm.
- 4 Tissue parameters and temperatures are listed on the SAR plot.
- 5 Battery Type Standard Extended Slim
 Batteries are fully charged for all readings.
- 6 Test Signal Call Mode Manual Test cord Base Station Simulator
- 7 Justification for reduced test configurations: per FCC/OET Supplement C (July, 2001), if the SAR measured at the middle channel for each test configuration (Left, right, cheek/touch, tilt/ear, extended and retracted) is at least 3.0 dB lower than the SAR limit, testing at the high and low channels is optional for such test configuration(s).

11.5 Measurement Results (GSM1900 Head SAR Touch SIM I)

Frequency		Modulation	Conducted Power (dBm)		Battery	Phantom Position	Antenna Type	SAR(mW/g)
MHz	Channel		Begin	End				
1 850.2	512 (Low)	GSM1900	29.84	29.83	Standard	Left Ear	Intenna	0.721
1 880.00	661 (Mid)	GSM1900	29.82	29.82	Standard	Left Ear	Intenna	0.839
1 909.8	810 (High)	GSM1900	29.99	29.88	Standard	Left Ear	Intenna	0.690
1 850.2	512 (Low)	GSM1900	29.84	29.80	Standard	Right Ear	Intenna	0.798
1 880.00	661 (Mid)	GSM1900	29.82	29.78	Standard	Right Ear	Intenna	0.948
1 909.8	810 (High)	GSM1900	29.99	29.95	Standard	Right Ear	Intenna	0.878
ANSI/ IEEE C95.1 2005 – Safety Limit						Head		
Spatial Peak						1.6 W/kg (mW/g)		
Uncontrolled Exposure/ General Population						<small>Averaged over 1 gram</small>		

NOTES:

- The test data reported are the worst-case SAR value with the antenna-head position set in a typical configuration. Test procedures used are according to FCC/OET Bulletin 65, Supplement C [July 2001].
- All modes of operation were investigated and the worst-case are reported.
- Measured Depth of Simulating Tissue is 15.0 cm ± 0.2 cm.
- Tissue parameters and temperatures are listed on the SAR plot.
- Battery Type Standard Extended Slim
Batteries are fully charged for all readings.
- Test Signal Call Mode Manual Test cord Base Station Simulator

11.6 Measurement Results (GSM1900 Head SAR Touch SIM II)

Frequency		Modulation	Conducted Power (dBm)		Battery	Phantom Position	Antenna Type	SAR(mW/g)
MHz	Channel		Begin	End				
1 850.2	512 (Low)	GSM1900	29.74	29.88	Standard	Left Ear	Intenna	0.734
1 880.00	661 (Mid)	GSM1900	29.74	29.70	Standard	Left Ear	Intenna	0.847
1 909.8	810 (High)	GSM1900	29.93	29.99	Standard	Left Ear	Intenna	0.751
1 850.2	512 (Low)	GSM1900	29.74	29.70	Standard	Right Ear	Intenna	0.809
1 880.00	661 (Mid)	GSM1900	29.74	29.77	Standard	Right Ear	Intenna	0.949
1 909.8	810 (High)	GSM1900	29.93	29.80	Standard	Right Ear	Intenna	0.913
ANSI/ IEEE C95.1 2005 – Safety Limit						Head		
Spatial Peak						1.6 W/kg (mW/g)		
Uncontrolled Exposure/ General Population						<small>Averaged over 1 gram</small>		

NOTES:

- The test data reported are the worst-case SAR value with the antenna-head position set in a typical configuration. Test procedures used are according to FCC/OET Bulletin 65, Supplement C [July 2001].
- All modes of operation were investigated and the worst-case are reported.
- Measured Depth of Simulating Tissue is 15.0 cm ± 0.2 cm.
- Tissue parameters and temperatures are listed on the SAR plot.
- Battery Type Standard Extended Slim
Batteries are fully charged for all readings.
- Test Signal Call Mode Manual Test cord Base Station Simulator

11.7 Measurement Results (GSM1900 Head SAR Tilt SIM I)

Frequency		Modulation	Conducted Power (dBm)		Battery	Phantom Position	Antenna Type	SAR(mW/g)
MHz	Channel		Begin	End				
1 880.0	661 (Mid)	GSM1900	29.82	29.78	Standard	Left Tilt 15°	Intenna	0.389
1 880.0	661 (Mid)	GSM1900	29.82	29.82	Standard	Right Tilt 15°	Intenna	0.288
ANSI/ IEEE C95.1 2005 – Safety Limit Spatial Peak Uncontrolled Exposure/ General Population						Head 1.6 W/kg (mW/g) <small>Averaged over 1 gram</small>		

NOTES:

- 1 The test data reported are the worst-case SAR value with the antenna-head position set in a typical configuration. Test procedures used are according to FCC/OET Bulletin 65, Supplement C [July 2001].
- 2 All modes of operation were investigated and the worst-case are reported.
- 3 Measured Depth of Simulating Tissue is 15.0 cm ± 0.2 cm.
- 4 Tissue parameters and temperatures are listed on the SAR plot.
- 5 Battery Type Standard Extended Slim
Batteries are fully charged for all readings.
- 6 Test Signal Call Mode Manual Test cord Base Station Simulator
- 7 Justification for reduced test configurations: per FCC/OET Supplement C (July, 2001), if the SAR measured at the middle channel for each test configuration (Left, right, cheek/touch, tilt/ear, extended and retracted) is at least 3.0 dB lower than the SAR limit, testing at the high and low channels is optional for such test configuration(s).

11.8 Measurement Results (GSM1900 Head SAR Tilt SIM II)

Frequency		Modulation	Conducted Power (dBm)		Battery	Phantom Position	Antenna Type	SAR(mW/g)
MHz	Channel		Begin	End				
1 880.0	661 (Mid)	GSM1900	29.79	29.81	Standard	Left Tilt 15°	Intenna	0.378
1 880.0	661 (Mid)	GSM1900	29.79	29.78	Standard	Right Tilt 15°	Intenna	0.311
ANSI/ IEEE C95.1 2005 – Safety Limit Spatial Peak Uncontrolled Exposure/ General Population						Head 1.6 W/kg (mW/g) Averaged over 1 gram		

NOTES:

- The test data reported are the worst-case SAR value with the antenna-head position set in a typical configuration. Test procedures used are according to FCC/OET Bulletin 65, Supplement C [July 2001].
- All modes of operation were investigated and the worst-case are reported.
- Measured Depth of Simulating Tissue is 15.0 cm ± 0.2 cm.
- Tissue parameters and temperatures are listed on the SAR plot.
- Battery Type Standard Extended Slim
Batteries are fully charged for all readings.
- Test Signal Call Mode Manual Test cord Base Station Simulator
- Justification for reduced test configurations: per FCC/OET Supplement C (July, 2001), if the SAR measured at the middle channel for each test configuration (Left, right, cheek/touch, tilt/ear, extended and retracted) is at least 3.0 dB lower than the SAR limit, testing at the high and low channels is optional for such test configuration(s).

11.9 Measurement Results (GSM850 Body SAR SIM I)

Frequency		Modulation	Conducted Power (dBm)		Configuration	Phantom Position	Antenna Type	SAR(mW/g)
MHz	Channel		Begin	End				
824.2	128 (Low)	GPRS 1Tx	32.01	31.96	Rear	2.0 cm without Holster	Intenna	0.558
824.2	128 (Low)	GPRS 2Tx	31.99	31.87	Rear	2.0 cm without Holster	Intenna	1.09
836.6	190 (Mid)	GPRS 2Tx	31.95	32.06	Rear	2.0 cm without Holster	Intenna	0.962
848.8	251 (High)	GPRS 2Tx	31.90	31.93	Rear	2.0 cm without Holster	Intenna	0.889
824.2	128 (Low)	GPRS 2Tx	31.99	31.92	Front	2.0 cm without Holster	Intenna	0.696
824.2	128 (Low)	GSM850	32.03	32.09	Rear	2.0 cm without Holster	Intenna	0.557
ANSI/ IEEE C95.1 2005 – Safety Limit Spatial Peak Uncontrolled Exposure/ General Population						Body 1.6 W/kg (mW/g) <small>Averaged over 1 gram</small>		

NOTES:

- 1 The test data reported are the worst-case SAR value with the antenna-head position set in a typical configuration. Test procedures used are according to FCC/OET Bulletin 65, Supplement C [July 2001].
- 2 All modes of operation were investigated and the worst-case are reported.
- 3 Measured Depth of Simulating Tissue is 15.0 cm ± 0.2 cm.
- 4 Tissue parameters and temperatures are listed on the SAR plot.
- 5 Battery Type Standard Extended Slim
Batteries are fully charged for all readings.
- 6 Test Signal Call Mode Manual Test cord Base Station Simulator
- 7 Both side of the phone were tested and the worst-case side is reported.
- 8 HEADSET was connected.
- 9 Test Configuration With Holster Without Holster

11.10 Measurement Results (GSM850 Body SAR SIM II)

Frequency		Modulation	Conducted Power (dBm)		Configuration	Phantom Position	Antenna Type	SAR(mW/g)
MHz	Channel		Begin	End				
824.2	128 (Low)	GPRS 1Tx	32.00	31.99	Rear	2.0 cm without Holster	Intenna	0.504
824.2	128 (Low)	GPRS 2Tx	31.98	31.88	Rear	2.0 cm without Holster	Intenna	0.994
836.6	190 (Mid)	GPRS 2Tx	31.94	31.88	Rear	2.0 cm without Holster	Intenna	0.889
848.8	251 (High)	GPRS 2Tx	31.92	31.88	Rear	2.0 cm without Holster	Intenna	0.818
824.2	128 (Low)	GPRS 2Tx	31.97	31.92	Front	2.0 cm without Holster	Intenna	0.733
824.2	128 (Low)	GSM850	32.01	31.92	Rear	2.0 cm without Holster	Intenna	0.51
ANSI/ IEEE C95.1 2005 – Safety Limit						Body		
Spatial Peak						1.6 W/kg (mW/g)		
Uncontrolled Exposure/ General Population						<small>Averaged over 1 gram</small>		

NOTES:

- The test data reported are the worst-case SAR value with the antenna-head position set in a typical configuration. Test procedures used are according to FCC/OET Bulletin 65, Supplement C [July 2001].
- All modes of operation were investigated and the worst-case are reported.
- Measured Depth of Simulating Tissue is 15.0 cm ± 0.2 cm.
- Tissue parameters and temperatures are listed on the SAR plot.
- Battery Type Standard Extended Slim
Batteries are fully charged for all readings.
- Test Signal Call Mode Manual Test cord Base Station Simulator
- Both side of the phone were tested and the worst-case side is reported.
- HEADSET was connected.
- Test Configuration With Holster Without Holster

11.11 Measurement Results (GSM1900 Body SAR SIM I)

Frequency		Modulation	Conducted Power (dBm)		Configuration	Phantom Position	Antenna Type	SAR(mW/g)
MHz	Channel		Begin	End				
1 880.0	661 (Mid)	GPRS 1Tx	29.79	29.79	Rear	2.0 cm without Holster	Intenna	0.177
1 880.0	661 (Mid)	GPRS 2Tx	29.73	29.72	Rear	2.0 cm without Holster	Intenna	0.343
1 880.0	661 (Mid)	GPRS 2Tx	29.73	29.63	Front	2.0 cm without Holster	Intenna	0.318
1 880.0	661 (Mid)	GSM1900	29.82	29.88	Rear	2.0 cm without Holster	Intenna	0.177
ANSI/ IEEE C95.1 2005 – Safety Limit						Body		
Spatial Peak						1.6 W/kg (mW/g)		
Uncontrolled Exposure/ General Population						<small>Averaged over 1 gram</small>		

NOTES:

- The test data reported are the worst-case SAR value with the antenna-head position set in a typical configuration. Test procedures used are according to FCC/OET Bulletin 65, Supplement C [July 2001].
- All modes of operation were investigated and the worst-case are reported.
- Measured Depth of Simulating Tissue is 15.0 cm ± 0.2 cm.
- Tissue parameters and temperatures are listed on the SAR plot.
- Battery Type Standard Extended Slim
Batteries are fully charged for all readings.
- Test Signal Call Mode Manual Test cord Base Station Simulator
- Both side of the phone were tested and the worst-case side is reported.
- HEADSET was connected.
- Test Configuration With Holster Without Holster
- Justification for reduced test configurations: per FCC/OET Supplement C (July, 2001), if the SAR measured at the middle channel for each test configuration (Left, right, cheek/touch, tilt/ear, extended and retracted) is at least 3.0 dB lower than the SAR limit, testing at the high and low channels is optional for such test configuration(s).

11.12 Measurement Results (GSM1900 Body SAR SIM II)

Frequency		Modulation	Conducted Power (dBm)		Configuration	Phantom Position	Antenna Type	SAR(mW/g)
MHz	Channel		Begin	End				
1 880.0	661 (Mid)	GPRS 1Tx	29.74	29.74	Rear	2.0 cm without Holster	Intenna	0.191
1 880.0	661 (Mid)	GPRS 2Tx	29.72	29.72	Rear	2.0 cm without Holster	Intenna	0.376
1 880.0	661 (Mid)	GPRS 2Tx	29.72	29.73	Front	2.0 cm without Holster	Intenna	0.298
1 880.0	661 (Mid)	GSM1900	29.79	29.79	Rear	2.0 cm without Holster	Intenna	0.192
ANSI/ IEEE C95.1 2005 – Safety Limit Spatial Peak Uncontrolled Exposure/ General Population						Body 1.6 W/kg (mW/g) <small>Averaged over 1 gram</small>		

NOTES:

- 1 The test data reported are the worst-case SAR value with the antenna-head position set in a typical configuration. Test procedures used are according to FCC/OET Bulletin 65, Supplement C [July 2001].
- 2 All modes of operation were investigated and the worst-case are reported.
- 3 Measured Depth of Simulating Tissue is 15.0 cm ± 0.2 cm.
- 4 Tissue parameters and temperatures are listed on the SAR plot.
- 5 Battery Type Standard Extended Slim
Batteries are fully charged for all readings.
- 6 Test Signal Call Mode Manual Test cord Base Station Simulator
- 7 Both side of the phone were tested and the worst-case side is reported.
- 8 HEADSET was connected.
- 9 Test Configuration With Holster Without Holster
- 10 Justification for reduced test configurations: per FCC/OET Supplement C (July, 2001), if the SAR measured at the middle channel for each test configuration (Left, right, cheek/touch, tilt/ear, extended and retracted) is at least 3.0 dB lower than the SAR limit, testing at the high and low channels is optional for such test configuration(s).

12. CONCLUSION

The SAR measurement indicates that the EUT complies with the RF radiation exposure limits of the ANSI/IEEE C95.1 2005.

These measurements are taken to simulate the RF effects exposure under worst-case conditions. Precise laboratory measures were taken to assure repeatability of the tests.

13. REFERENCES

- [1] Federal Communications Commission, OET Bulletin 65 (Edition 97-01), Supplement C (Edition 01-01), Evaluating Compliance with FCC Guidelines for Human Exposure to Radio frequency Electromagnetic Fields, July 2001.
- [2] IEEE Standards Coordinating Committee 34 – IEEE Std. 1528-2003, IEEE Recommended Practice for Determining the Peak Spatial-Average Specific Absorption Rate (SAR) in the Human Body from Wireless Communications Devices.
- [3] Federal Communications Commission, ET Docket 93-62, Guidelines for Evaluating the Environmental Effects of Radio frequency Radiation, Aug. 1996.
- [4] ANSI/IEEE C95.1 - 1991, American National Standard safety levels with respect to human exposure to radio frequency electromagnetic fields, 300 kHz to 100 GHz, New York: IEEE, Aug. 1992
- [5] ANSI/IEEE C95.3 - 1991, IEEE Recommended Practice for the Measurement of Potentially Hazardous Electromagnetic Fields - RF and Microwave, New York: IEEE, 1992.
- [6] NCRP, National Council on Radiation Protection and Measurements, Biological Effects and Exposure Criteria for Radio Frequency Electromagnetic Fields, NCRP Report No. 86, 1986. Reprinted Feb. 1995.
- [7] T. Schmid, O. Egger, N. Kuster, Automated E-field scanning system for dosimetric assessments, IEEE Transaction on Microwave Theory and Techniques, vol. 44, Jan. 1996, pp. 105-113.
- [8] K. Pokovic, T. Schmid, N. Kuster, Robust setup for precise calibration of E-field probes in tissue simulating liquids at mobile communications frequencies, ICECOM97, Oct. 1997, pp. 120-124.
- [9] K. Pokovic, T. Schmid, and N. Kuster, E-field Probe with improved isotropy in brain simulating liquids, Proceedings of the ELMAR, Zadar, Croatia, June 23-25, 1996, pp. 172-175.
- [10] Schmid & Partner Engineering AG, Application Note: Data Storage and Evaluation, June 1998, p2.
- [11] V. Hombach, K. Meier, M. Burkhardt, E. Kuhn, N. Kuster, The Dependence of EM Energy Absorption upon Human Head Modeling at 900 MHz, IEEE Transaction on Microwave Theory and Techniques, vol. 44 no. 10, Oct. 1996, pp. 1865-1873.
- [12] N. Kuster and Q. Balzano, Energy absorption mechanism by biological bodies in the near field of dipole antennas above 300 MHz, IEEE Transaction on Vehicular Technology, vol. 41, no. 1, Feb. 1992, pp. 17-23.
- [13] G. Hartsgrove, A. Kraszewski, A. Surowiec, Simulated Biological Materials for Electromagnetic Radiation Absorption Studies, University of Ottawa, Bioelectromagnetics, Canada: 1987, pp. 29-36.
- [14] Q. Balzano, O. Garay, T. Manning Jr., Electromagnetic Energy Exposure of Simulated Users of Portable Cellular Telephones, IEEE Transactions on Vehicular Technology, vol. 44, no.3, Aug. 1995.
- [15] W. Gander, Computer mathematic, Birkhaeuser, Basel, 1992.
- [16] W.H. Press, S.A. Teukolsky, W.T. Vetterling, and B.P. Flannery, Numerical Recipes in C, The Art of Scientific Computing, Second edition, Cambridge University Press, 1992.
- [17] Federal Communications Commission, OET Bulletin 65, Evaluating Compliance with FCC Guidelines for Human Exposure to Radiofrequency Electromagnetic Fields. Supplement C, Dec. 1997.
- [18] N. Kuster, R. Kastle, T. Schmid, Dosimetric evaluation of mobile communications equipment with known precision, IEEE Transaction on Communications, vol. E80-B, no. 5, May 1997, pp. 645-652.
- [19] CENELEC CLC/SC111B, European Prestandard (prENV 50166-2), Human Exposure to Electromagnetic Fields High-frequency: 10 kHz-300 GHz, Jan. 1995.
- [20] Prof. Dr. Niels Kuster, ETH, Eidgenössische Technische Hochschule Zürich, Dosimetric Evaluation of the Cellular Phone.
- [21] SAR Evaluation of Handsets with Multiple Transmitters and Antennas #648474.

Attachment 1. – SAR Test Plots

Test Laboratory: HCT CO., LTD
EUT Type: Cellular/PCS GSM Phone with Bluetooth
GPRS Class 10 and GPRS mode class B(GPRS and GSM, but not simultaneously)
Liquid Temperature: 21.3 °C
Ambient Temperature: 21.5 °C
Test Date: Dec.02, 2009

DUT: GX200; Type: Bar; Serial: #1

Communication System: GSM 850; Frequency: 824.2 MHz; Duty Cycle: 1:8.3
Medium parameters used: $f = 825$ MHz; $\sigma = 0.889$ mho/m; $\epsilon_r = 42.2$; $\rho = 1000$ kg/m³
Phantom section: Left Section ; Measurement SW: DASY4, V4.7 Build 80; Postprocessing SW: SEMCAD, V1.8 Build 176

DASY4 Configuration:

- Probe: ET3DV6 - SN1631; ConvF(5.83, 5.83, 5.83); Calibrated: 2009-06-24
- Sensor-Surface: 4mm (Mechanical Surface Detection)
- Electronics: DAE3 Sn446; Calibrated: 2009-05-22
- Phantom: 835/900 Phantom ; Type: SAM

Left touch 128/Area Scan (51x81x1): Measurement grid: dx=15mm, dy=15mm
Maximum value of SAR (interpolated) = 1.10 mW/g

Left touch 128/Zoom Scan (5x5x7)/Cube 0: Measurement grid: dx=8mm, dy=8mm, dz=5mm
Reference Value = 12.1 V/m; Power Drift = -0.0277 dB
Peak SAR (extrapolated) = 1.32 W/kg
SAR(1 g) = 1.01 mW/g; SAR(10 g) = 0.729 mW/g
Maximum value of SAR (measured) = 1.08 mW/g

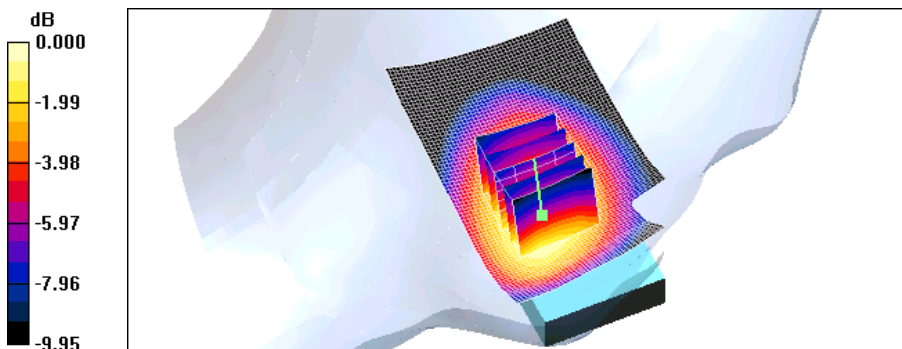

Test Laboratory: HCT CO., LTD
EUT Type: Cellular/PCS GSM Phone with Bluetooth
GPRS Class 10 and GPRS mode class B(GPRS and GSM, but not simultaneously)
Liquid Temperature: 21.3 °C
Ambient Temperature: 21.5 °C
Test Date: Dec.02, 2009

DUT: GX200; Type: Bar; Serial: #1

Communication System: GSM 850; Frequency: 836.6 MHz; Duty Cycle: 1:8.3
Medium parameters used (interpolated): $f = 836.6$ MHz; $\sigma = 0.898$ mho/m; $\epsilon_r = 42.1$; $\rho = 1000$ kg/m³
Phantom section: Left Section ; Measurement SW: DASY4, V4.7 Build 80; Postprocessing SW: SEMCAD, V1.8 Build 176

DASY4 Configuration:

- Probe: ET3DV6 - SN1631; ConvF(5.83, 5.83, 5.83); Calibrated: 2009-06-24
- Sensor-Surface: 4mm (Mechanical Surface Detection)
- Electronics: DAE3 Sn446; Calibrated: 2009-05-22
- Phantom: 835/900 Phantom ; Type: SAM

Left touch 190/Area Scan (51x81x1): Measurement grid: dx=15mm, dy=15mm

[Info: Interpolated medium parameters used for SAR evaluation.](#)

Maximum value of SAR (interpolated) = 1.09 mW/g

Left touch 190/Zoom Scan (5x5x7)/Cube 0: Measurement grid: dx=8mm, dy=8mm, dz=5mm

Reference Value = 12.0 V/m; Power Drift = -0.021 dB

Peak SAR (extrapolated) = 1.35 W/kg

SAR(1 g) = 1.04 mW/g; SAR(10 g) = 0.744 mW/g

[Info: Interpolated medium parameters used for SAR evaluation.](#)

Maximum value of SAR (measured) = 1.11 mW/g

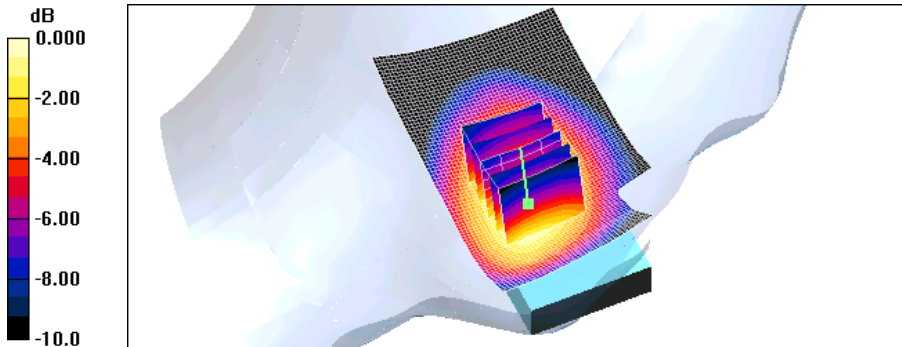

0 dB = 1.11mW/g

Test Laboratory: HCT CO., LTD
EUT Type: Cellular/PCS GSM Phone with Bluetooth
GPRS Class 10 and GPRS mode class B(GPRS and GSM, but not simultaneously)
Liquid Temperature: 21.3 °C
Ambient Temperature: 21.5 °C
Test Date: Dec.02, 2009

DUT: GX200; Type: Bar; Serial: #1

Communication System: GSM 850; Frequency: 848.8 MHz; Duty Cycle: 1:8.3
Medium parameters used (interpolated): $f = 848.8$ MHz; $\sigma = 0.909$ mho/m; $\epsilon_r = 42$; $\rho = 1000$ kg/m³
Phantom section: Left Section ; Measurement SW: DASY4, V4.7 Build 80; Postprocessing SW: SEMCAD, V1.8 Build 176

DASY4 Configuration:

- Probe: ET3DV6 - SN1631; ConvF(5.83, 5.83, 5.83); Calibrated: 2009-06-24
- Sensor-Surface: 4mm (Mechanical Surface Detection)
- Electronics: DAE3 Sn446; Calibrated: 2009-05-22
- Phantom: 835/900 Phantom ; Type: SAM

Left touch 251/Area Scan (51x81x1): Measurement grid: dx=15mm, dy=15mm

[Info: Interpolated medium parameters used for SAR evaluation.](#)

Maximum value of SAR (interpolated) = 1.06 mW/g

Left touch 251/Zoom Scan (5x5x7)/Cube 0: Measurement grid: dx=8mm, dy=8mm, dz=5mm

Reference Value = 11.9 V/m; Power Drift = -0.0389 dB

Peak SAR (extrapolated) = 1.30 W/kg

SAR(1 g) = 0.997 mW/g; SAR(10 g) = 0.714 mW/g

[Info: Interpolated medium parameters used for SAR evaluation.](#)

Maximum value of SAR (measured) = 1.06 mW/g

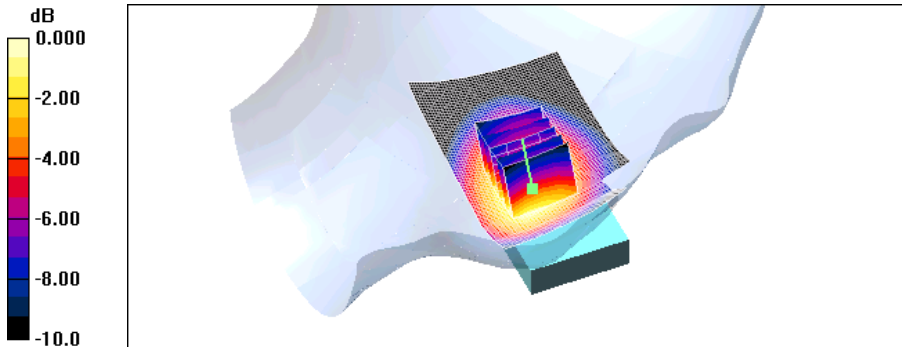

0 dB = 1.06mW/g

Test Laboratory: HCT CO., LTD
EUT Type: Cellular/PCS GSM Phone with Bluetooth
GPRS Class 10 and GPRS mode class B(GPRS and GSM, but not simultaneously)
Liquid Temperature: 21.3 °C
Ambient Temperature: 21.5 °C
Test Date: Dec.02, 2009

DUT: GX200; Type: Bar; Serial: #1

Communication System: GSM 850; Frequency: 824.2 MHz; Duty Cycle: 1:8.3
Medium parameters used: $f = 825$ MHz; $\sigma = 0.889$ mho/m; $\epsilon_r = 42.2$; $\rho = 1000$ kg/m³
Phantom section: Right Section ; Measurement SW: DASY4, V4.7 Build 80; Postprocessing SW: SEMCAD, V1.8 Build 176

DASY4 Configuration:

- Probe: ET3DV6 - SN1631; ConvF(5.83, 5.83, 5.83); Calibrated: 2009-06-24
- Sensor-Surface: 4mm (Mechanical Surface Detection)
- Electronics: DAE3 Sn446; Calibrated: 2009-05-22
- Phantom: 835/900 Phantom ; Type: SAM

Right touch 128/Area Scan (51x81x1): Measurement grid: dx=15mm, dy=15mm

Maximum value of SAR (interpolated) = 1.24 mW/g

Right touch 128/Zoom Scan (5x5x7)/Cube 0: Measurement grid: dx=8mm, dy=8mm, dz=5mm

Reference Value = 13.1 V/m; Power Drift = -0.104 dB

Peak SAR (extrapolated) = 1.48 W/kg

SAR(1 g) = 1.18 mW/g; SAR(10 g) = 0.857 mW/g

Maximum value of SAR (measured) = 1.27 mW/g

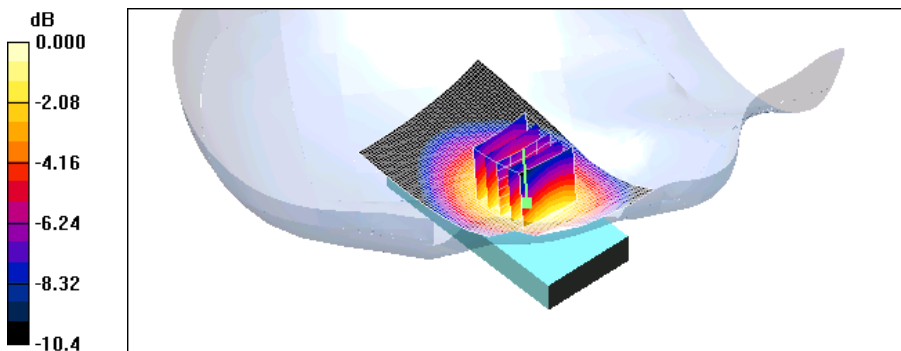

0 dB = 1.27mW/g

Test Laboratory: HCT CO., LTD
EUT Type: Cellular/PCS GSM Phone with Bluetooth
GPRS Class 10 and GPRS mode class B(GPRS and GSM, but not simultaneously)
Liquid Temperature: 21.3 °C
Ambient Temperature: 21.5 °C
Test Date: Dec.02, 2009

DUT: GX200; Type: Bar; Serial: #1

Communication System: GSM 850; Frequency: 836.6 MHz; Duty Cycle: 1:8.3
Medium parameters used (interpolated): $f = 836.6$ MHz; $\sigma = 0.898$ mho/m; $\epsilon_r = 42.1$; $\rho = 1000$ kg/m³
Phantom section: Right Section ; Measurement SW: DASY4, V4.7 Build 80; Postprocessing SW: SEMCAD, V1.8 Build 176

DASY4 Configuration:

- Probe: ET3DV6 - SN1631; ConvF(5.83, 5.83, 5.83); Calibrated: 2009-06-24
- Sensor-Surface: 4mm (Mechanical Surface Detection)
- Electronics: DAE3 Sn446; Calibrated: 2009-05-22
- Phantom: 835/900 Phantom ; Type: SAM

Right touch 190/Area Scan (51x81x1): Measurement grid: dx=15mm, dy=15mm

[Info: Interpolated medium parameters used for SAR evaluation.](#)

Maximum value of SAR (interpolated) = 1.22 mW/g

Right touch 190/Zoom Scan (5x5x7)/Cube 0: Measurement grid: dx=8mm, dy=8mm, dz=5mm

Reference Value = 12.5 V/m; Power Drift = 0.031 dB

Peak SAR (extrapolated) = 1.46 W/kg

SAR(1 g) = 1.16 mW/g; SAR(10 g) = 0.834 mW/g

[Info: Interpolated medium parameters used for SAR evaluation.](#)

Maximum value of SAR (measured) = 1.24 mW/g

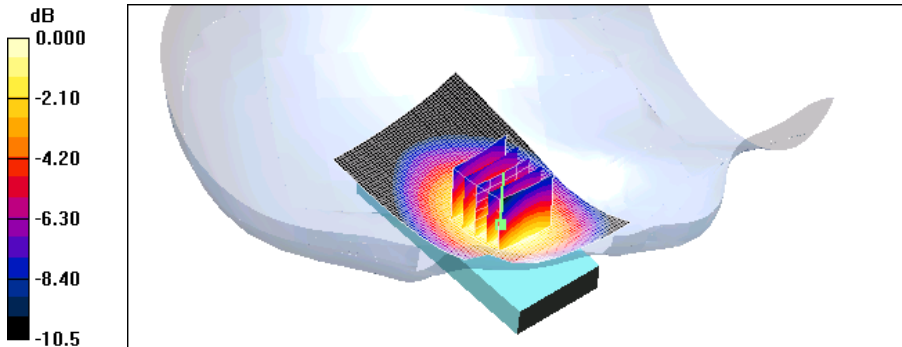

0 dB = 1.24mW/g

Test Laboratory: HCT CO., LTD
EUT Type: Cellular/PCS GSM Phone with Bluetooth
GPRS Class 10 and GPRS mode class B(GPRS and GSM, but not simultaneously)
Liquid Temperature: 21.3 °C
Ambient Temperature: 21.5 °C
Test Date: Dec.02, 2009

DUT: GX200; Type: Bar; Serial: #1

Communication System: GSM 850; Frequency: 848.8 MHz; Duty Cycle: 1:8.3
Medium parameters used (interpolated): $f = 848.8$ MHz; $\sigma = 0.909$ mho/m; $\epsilon_r = 42$; $\rho = 1000$ kg/m³
Phantom section: Right Section ; Measurement SW: DASY4, V4.7 Build 80; Postprocessing SW: SEMCAD, V1.8 Build 176

DASY4 Configuration:

- Probe: ET3DV6 - SN1631; ConvF(5.83, 5.83, 5.83); Calibrated: 2009-06-24
- Sensor-Surface: 4mm (Mechanical Surface Detection)
- Electronics: DAE3 Sn446; Calibrated: 2009-05-22
- Phantom: 835/900 Phantom ; Type: SAM

Right touch 251/Area Scan (51x81x1): Measurement grid: dx=15mm, dy=15mm

[Info: Interpolated medium parameters used for SAR evaluation.](#)

Maximum value of SAR (interpolated) = 1.00 mW/g

Right touch 251/Zoom Scan (5x5x7)/Cube 0: Measurement grid: dx=8mm, dy=8mm, dz=5mm

Reference Value = 11.4 V/m; Power Drift = -0.057 dB

Peak SAR (extrapolated) = 1.23 W/kg

SAR(1 g) = 0.954 mW/g; SAR(10 g) = 0.686 mW/g

[Info: Interpolated medium parameters used for SAR evaluation.](#)

Maximum value of SAR (measured) = 1.02 mW/g

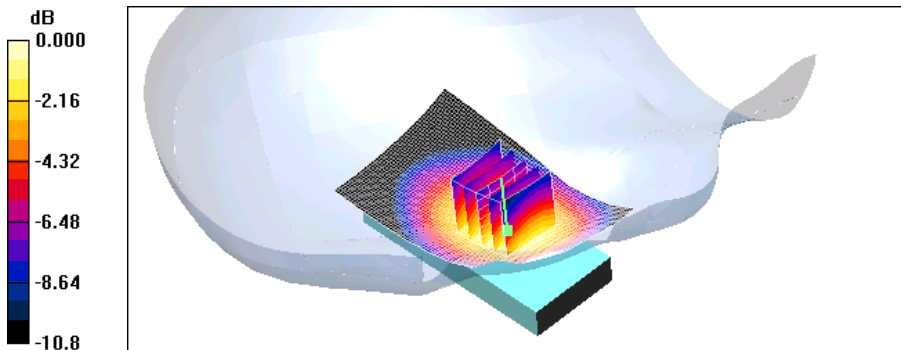

0 dB = 1.02mW/g

Test Laboratory: HCT CO., LTD
EUT Type: Cellular/PCS GSM Phone with Bluetooth
GPRS Class 10 and GPRS mode class B(GPRS and GSM, but not simultaneously)
Liquid Temperature: 21.3 °C
Ambient Temperature: 21.5 °C
Test Date: Dec.02, 2009

DUT: GX200; Type: Bar; Serial: #1

Communication System: GSM 850; Frequency: 824.2 MHz; Duty Cycle: 1:8.3
Medium parameters used: $f = 825$ MHz; $\sigma = 0.889$ mho/m; $\epsilon_r = 42.2$; $\rho = 1000$ kg/m³
Phantom section: Left Section ; Measurement SW: DASY4, V4.7 Build 80; Postprocessing SW: SEMCAD, V1.8 Build 176

DASY4 Configuration:

- Probe: ET3DV6 - SN1631; ConvF(5.83, 5.83, 5.83); Calibrated: 2009-06-24
- Sensor-Surface: 4mm (Mechanical Surface Detection)
- Electronics: DAE3 Sn446; Calibrated: 2009-05-22
- Phantom: 835/900 Phantom ; Type: SAM

Left touch 128/Area Scan (51x81x1): Measurement grid: dx=15mm, dy=15mm

Maximum value of SAR (interpolated) = 1.26 mW/g

Left touch 128/Zoom Scan (5x5x7)/Cube 0: Measurement grid: dx=8mm, dy=8mm, dz=5mm

Reference Value = 13.3 V/m; Power Drift = -0.130 dB

Peak SAR (extrapolated) = 1.53 W/kg

SAR(1 g) = 1.19 mW/g; SAR(10 g) = 0.855 mW/g

Maximum value of SAR (measured) = 1.26 mW/g

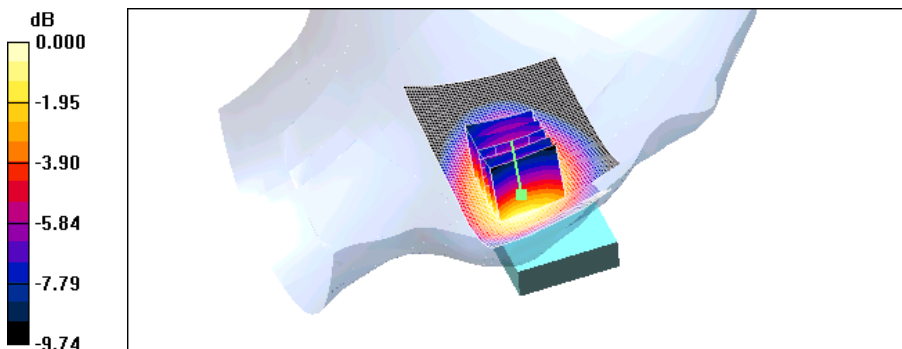

0 dB = 1.26mW/g

Test Laboratory: HCT CO., LTD
EUT Type: Cellular/PCS GSM Phone with Bluetooth
GPRS Class 10 and GPRS mode class B(GPRS and GSM, but not simultaneously)
Liquid Temperature: 21.3 °C
Ambient Temperature: 21.5 °C
Test Date: Dec.02, 2009

DUT: GX200; Type: Bar; Serial: #1

Communication System: GSM 850; Frequency: 836.6 MHz; Duty Cycle: 1:8.3
Medium parameters used (interpolated): $f = 836.6$ MHz; $\sigma = 0.898$ mho/m; $\epsilon_r = 42.1$; $\rho = 1000$ kg/m³
Phantom section: Left Section ; Measurement SW: DASY4, V4.7 Build 80; Postprocessing SW: SEMCAD, V1.8 Build 176

DASY4 Configuration:

- Probe: ET3DV6 - SN1631; ConvF(5.83, 5.83, 5.83); Calibrated: 2009-06-24
- Sensor-Surface: 4mm (Mechanical Surface Detection)
- Electronics: DAE3 Sn446; Calibrated: 2009-05-22
- Phantom: 835/900 Phantom ; Type: SAM

Left touch 190/Area Scan (51x81x1): Measurement grid: dx=15mm, dy=15mm

[Info: Interpolated medium parameters used for SAR evaluation.](#)

Maximum value of SAR (interpolated) = 1.16 mW/g

Left touch 190/Zoom Scan (5x5x7)/Cube 0: Measurement grid: dx=8mm, dy=8mm, dz=5mm

Reference Value = 12.6 V/m; Power Drift = -0.141 dB

Peak SAR (extrapolated) = 1.42 W/kg

SAR(1 g) = 1.08 mW/g; SAR(10 g) = 0.780 mW/g

[Info: Interpolated medium parameters used for SAR evaluation.](#)

Maximum value of SAR (measured) = 1.16 mW/g

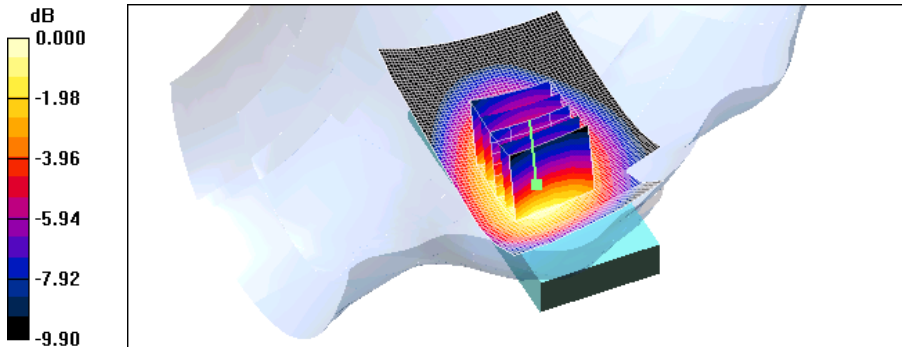

0 dB = 1.16mW/g

Test Laboratory: HCT CO., LTD
EUT Type: Cellular/PCS GSM Phone with Bluetooth
GPRS Class 10 and GPRS mode class B(GPRS and GSM, but not simultaneously)
Liquid Temperature: 21.3 °C
Ambient Temperature: 21.5 °C
Test Date: Dec.02, 2009

DUT: GX200; Type: Bar; Serial: #1

Communication System: GSM 850; Frequency: 848.8 MHz; Duty Cycle: 1:8.3
Medium parameters used (interpolated): $f = 848.8$ MHz; $\sigma = 0.909$ mho/m; $\epsilon_r = 42$; $\rho = 1000$ kg/m³
Phantom section: Left Section ; Measurement SW: DASY4, V4.7 Build 80; Postprocessing SW: SEMCAD, V1.8 Build 176

DASY4 Configuration:

- Probe: ET3DV6 - SN1631; ConvF(5.83, 5.83, 5.83); Calibrated: 2009-06-24
- Sensor-Surface: 4mm (Mechanical Surface Detection)
- Electronics: DAE3 Sn446; Calibrated: 2009-05-22
- Phantom: 835/900 Phantom ; Type: SAM

Left touch 251/Area Scan (51x81x1): Measurement grid: dx=15mm, dy=15mm

[Info: Interpolated medium parameters used for SAR evaluation.](#)

Maximum value of SAR (interpolated) = 1.01 mW/g

Left touch 251/Zoom Scan (5x5x7)/Cube 0: Measurement grid: dx=8mm, dy=8mm, dz=5mm

Reference Value = 11.6 V/m; Power Drift = -0.059 dB

Peak SAR (extrapolated) = 1.24 W/kg

SAR(1 g) = 0.955 mW/g; SAR(10 g) = 0.686 mW/g

[Info: Interpolated medium parameters used for SAR evaluation.](#)

Maximum value of SAR (measured) = 1.01 mW/g

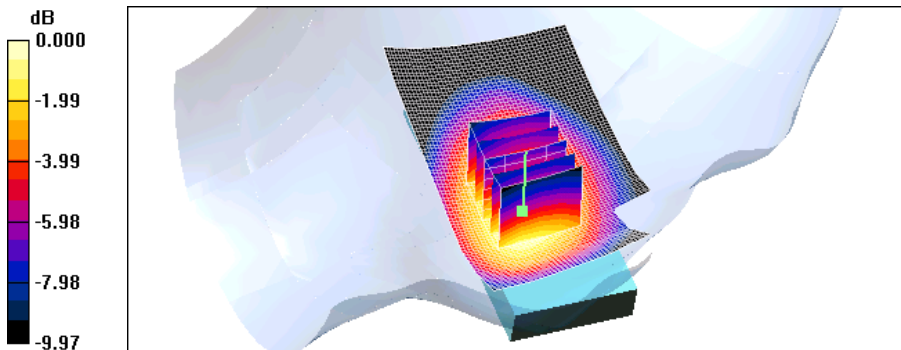

0 dB = 1.01mW/g

Test Laboratory: HCT CO., LTD
EUT Type: Cellular/PCS GSM Phone with Bluetooth
GPRS Class 10 and GPRS mode class B(GPRS and GSM, but not simultaneously)
Liquid Temperature: 21.3 °C
Ambient Temperature: 21.5 °C
Test Date: Dec.02, 2009

DUT: GX200; Type: Bar; Serial: #1

Communication System: GSM 850; Frequency: 824.2 MHz; Duty Cycle: 1:8.3
Medium parameters used: $f = 825$ MHz; $\sigma = 0.889$ mho/m; $\epsilon_r = 42.2$; $\rho = 1000$ kg/m³
Phantom section: Right Section ; Measurement SW: DASY4, V4.7 Build 80; Postprocessing SW: SEMCAD, V1.8 Build 176

DASY4 Configuration:

- Probe: ET3DV6 - SN1631; ConvF(5.83, 5.83, 5.83); Calibrated: 2009-06-24
- Sensor-Surface: 4mm (Mechanical Surface Detection)
- Electronics: DAE3 Sn446; Calibrated: 2009-05-22
- Phantom: 835/900 Phantom ; Type: SAM

Right touch 128/Area Scan (51x81x1): Measurement grid: dx=15mm, dy=15mm
Maximum value of SAR (interpolated) = 1.36 mW/g

Right touch 128/Zoom Scan (5x5x7)/Cube 0: Measurement grid: dx=8mm, dy=8mm, dz=5mm
Reference Value = 13.4 V/m; Power Drift = -0.134 dB
Peak SAR (extrapolated) = 1.60 W/kg
SAR(1 g) = 1.27 mW/g; SAR(10 g) = 0.922 mW/g
Maximum value of SAR (measured) = 1.36 mW/g

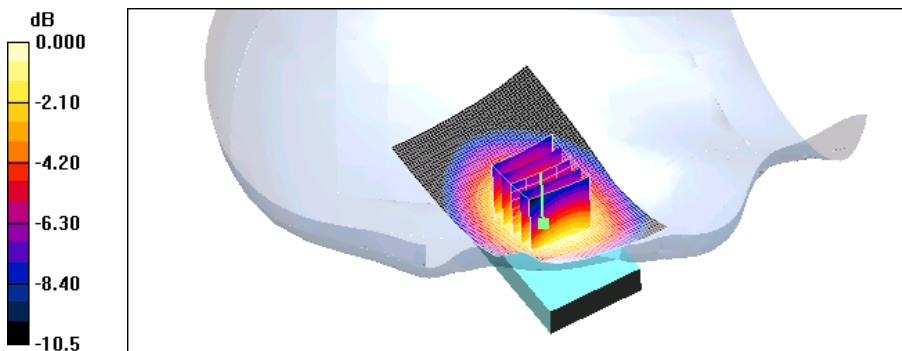

0 dB = 1.36mW/g

Test Laboratory: HCT CO., LTD
EUT Type: Cellular/PCS GSM Phone with Bluetooth
GPRS Class 10 and GPRS mode class B(GPRS and GSM, but not simultaneously)
Liquid Temperature: 21.3 °C
Ambient Temperature: 21.5 °C
Test Date: Dec.02, 2009

DUT: GX200; Type: Bar; Serial: #1

Communication System: GSM 850; Frequency: 836.6 MHz; Duty Cycle: 1:8.3
Medium parameters used (interpolated): $f = 836.6$ MHz; $\sigma = 0.898$ mho/m; $\epsilon_r = 42.1$; $\rho = 1000$ kg/m³
Phantom section: Right Section ; Measurement SW: DASY4, V4.7 Build 80; Postprocessing SW: SEMCAD, V1.8 Build 176

DASY4 Configuration:

- Probe: ET3DV6 - SN1631; ConvF(5.83, 5.83, 5.83); Calibrated: 2009-06-24
- Sensor-Surface: 4mm (Mechanical Surface Detection)
- Electronics: DAE3 Sn446; Calibrated: 2009-05-22
- Phantom: 835/900 Phantom ; Type: SAM

Right touch 190/Area Scan (51x81x1): Measurement grid: dx=15mm, dy=15mm

[Info: Interpolated medium parameters used for SAR evaluation.](#)

Maximum value of SAR (interpolated) = 1.24 mW/g

Right touch 190/Zoom Scan (5x5x7)/Cube 0: Measurement grid: dx=8mm, dy=8mm, dz=5mm

Reference Value = 12.5 V/m; Power Drift = -0.083 dB

Peak SAR (extrapolated) = 1.44 W/kg

SAR(1 g) = 1.15 mW/g; SAR(10 g) = 0.836 mW/g

[Info: Interpolated medium parameters used for SAR evaluation.](#)

Maximum value of SAR (measured) = 1.23 mW/g

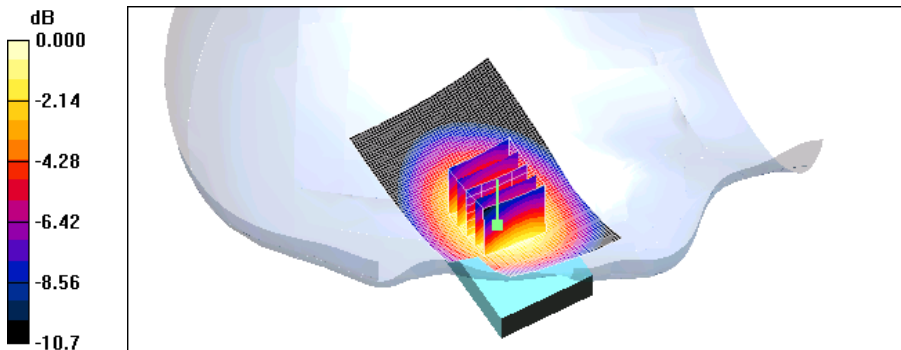

0 dB = 1.23mW/g

Test Laboratory: HCT CO., LTD
EUT Type: Cellular/PCS GSM Phone with Bluetooth
GPRS Class 10 and GPRS mode class B(GPRS and GSM, but not simultaneously)
Liquid Temperature: 21.3 °C
Ambient Temperature: 21.5 °C
Test Date: Dec.02, 2009

DUT: GX200; Type: Bar; Serial: #1

Communication System: GSM 850; Frequency: 848.8 MHz; Duty Cycle: 1:8.3
Medium parameters used (interpolated): $f = 848.8$ MHz; $\sigma = 0.909$ mho/m; $\epsilon_r = 42$; $\rho = 1000$ kg/m³
Phantom section: Right Section ; Measurement SW: DASY4, V4.7 Build 80; Postprocessing SW: SEMCAD, V1.8 Build 176

DASY4 Configuration:

- Probe: ET3DV6 - SN1631; ConvF(5.83, 5.83, 5.83); Calibrated: 2009-06-24
- Sensor-Surface: 4mm (Mechanical Surface Detection)
- Electronics: DAE3 Sn446; Calibrated: 2009-05-22
- Phantom: 835/900 Phantom ; Type: SAM

Right touch 251/Area Scan (51x81x1): Measurement grid: dx=15mm, dy=15mm

[Info: Interpolated medium parameters used for SAR evaluation.](#)

Maximum value of SAR (interpolated) = 1.01 mW/g

Right touch 251/Zoom Scan (5x5x7)/Cube 0: Measurement grid: dx=8mm, dy=8mm, dz=5mm

Reference Value = 11.2 V/m; Power Drift = -0.110 dB

Peak SAR (extrapolated) = 1.22 W/kg

SAR(1 g) = 0.960 mW/g; SAR(10 g) = 0.692 mW/g

[Info: Interpolated medium parameters used for SAR evaluation.](#)

Maximum value of SAR (measured) = 1.03 mW/g

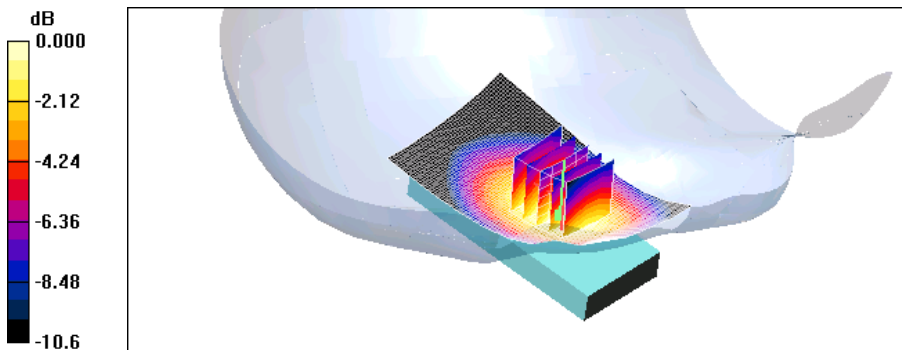

0 dB = 1.03mW/g

Test Laboratory: HCT CO., LTD
EUT Type: Cellular/PCS GSM Phone with Bluetooth
GPRS Class 10 and GPRS mode class B(GPRS and GSM, but not simultaneously)
Liquid Temperature: 21.3 °C
Ambient Temperature: 21.5 °C
Test Date: Dec.02, 2009

DUT: GX200; Type: Bar; Serial: #1

Communication System: GSM 850; Frequency: 836.6 MHz; Duty Cycle: 1:8.3
Medium parameters used (interpolated): $f = 836.6$ MHz; $\sigma = 0.898$ mho/m; $\epsilon_r = 42.1$; $\rho = 1000$ kg/m³
Phantom section: Left Section ; Measurement SW: DASY4, V4.7 Build 80; Postprocessing SW: SEMCAD, V1.8 Build 176

DASY4 Configuration:

- Probe: ET3DV6 - SN1631; ConvF(5.83, 5.83, 5.83); Calibrated: 2009-06-24
- Sensor-Surface: 4mm (Mechanical Surface Detection)
- Electronics: DAE3 Sn446; Calibrated: 2009-05-22
- Phantom: 835/900 Phantom ; Type: SAM

Left tilt 190/Area Scan (51x81x1): Measurement grid: dx=15mm, dy=15mm

[Info: Interpolated medium parameters used for SAR evaluation.](#)

Maximum value of SAR (interpolated) = 0.609 mW/g

Left tilt 190/Zoom Scan (5x5x7)/Cube 0: Measurement grid: dx=8mm, dy=8mm, dz=5mm

Reference Value = 17.7 V/m; Power Drift = -0.028 dB

Peak SAR (extrapolated) = 0.722 W/kg

SAR(1 g) = 0.577 mW/g; SAR(10 g) = 0.428 mW/g

[Info: Interpolated medium parameters used for SAR evaluation.](#)

Maximum value of SAR (measured) = 0.607 mW/g

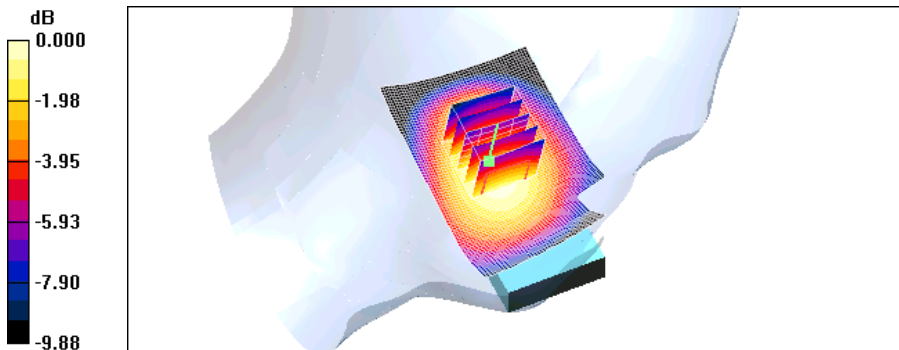

0 dB = 0.607mW/g

Test Laboratory: HCT CO., LTD
EUT Type: Cellular/PCS GSM Phone with Bluetooth
GPRS Class 10 and GPRS mode class B(GPRS and GSM, but not simultaneously)
Liquid Temperature: 21.3 °C
Ambient Temperature: 21.5 °C
Test Date: Dec.02, 2009

DUT: GX200; Type: Bar; Serial: #1

Communication System: GSM 850; Frequency: 836.6 MHz; Duty Cycle: 1:8.3
Medium parameters used (interpolated): $f = 836.6$ MHz; $\sigma = 0.898$ mho/m; $\epsilon_r = 42.1$; $\rho = 1000$ kg/m³
Phantom section: Right Section ; Measurement SW: DASY4, V4.7 Build 80; Postprocessing SW: SEMCAD, V1.8 Build 176

DASY4 Configuration:

- Probe: ET3DV6 - SN1631; ConvF(5.83, 5.83, 5.83); Calibrated: 2009-06-24
- Sensor-Surface: 4mm (Mechanical Surface Detection)
- Electronics: DAE3 Sn446; Calibrated: 2009-05-22
- Phantom: 835/900 Phantom ; Type: SAM

Right tilt 190/Area Scan (51x81x1): Measurement grid: dx=15mm, dy=15mm

[Info: Interpolated medium parameters used for SAR evaluation.](#)

Maximum value of SAR (interpolated) = 0.552 mW/g

Right tilt 190/Zoom Scan (5x5x7)/Cube 0: Measurement grid: dx=8mm, dy=8mm, dz=5mm

Reference Value = 16.6 V/m; Power Drift = 0.118 dB

Peak SAR (extrapolated) = 0.668 W/kg

SAR(1 g) = 0.538 mW/g; SAR(10 g) = 0.398 mW/g

[Info: Interpolated medium parameters used for SAR evaluation.](#)

Maximum value of SAR (measured) = 0.568 mW/g

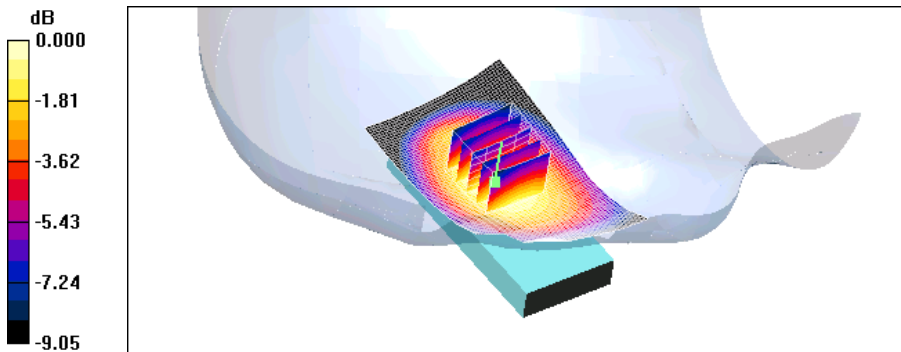

0 dB = 0.568mW/g

Test Laboratory: HCT CO., LTD
EUT Type: Cellular/PCS GSM Phone with Bluetooth
GPRS Class 10 and GPRS mode class B(GPRS and GSM, but not simultaneously)
Liquid Temperature: 21.3 °C
Ambient Temperature: 21.5 °C
Test Date: Dec.02, 2009

DUT: GX200; Type: Bar; Serial: #1

Communication System: GSM 850; Frequency: 836.6 MHz; Duty Cycle: 1:8.3
Medium parameters used (interpolated): $f = 836.6$ MHz; $\sigma = 0.898$ mho/m; $\epsilon_r = 42.1$; $\rho = 1000$ kg/m³
Phantom section: Left Section ; Measurement SW: DASY4, V4.7 Build 80; Postprocessing SW: SEMCAD, V1.8 Build 176

DASY4 Configuration:

- Probe: ET3DV6 - SN1631; ConvF(5.83, 5.83, 5.83); Calibrated: 2009-06-24
- Sensor-Surface: 4mm (Mechanical Surface Detection)
- Electronics: DAE3 Sn446; Calibrated: 2009-05-22
- Phantom: 835/900 Phantom ; Type: SAM

Left tilt 190/Area Scan (51x81x1): Measurement grid: dx=15mm, dy=15mm

[Info: Interpolated medium parameters used for SAR evaluation.](#)

Maximum value of SAR (interpolated) = 0.614 mW/g

Left tilt 190/Zoom Scan (5x5x7)/Cube 0: Measurement grid: dx=8mm, dy=8mm, dz=5mm

Reference Value = 17.9 V/m; Power Drift = -0.068 dB

Peak SAR (extrapolated) = 0.732 W/kg

SAR(1 g) = 0.582 mW/g; SAR(10 g) = 0.429 mW/g

[Info: Interpolated medium parameters used for SAR evaluation.](#)

Maximum value of SAR (measured) = 0.621 mW/g

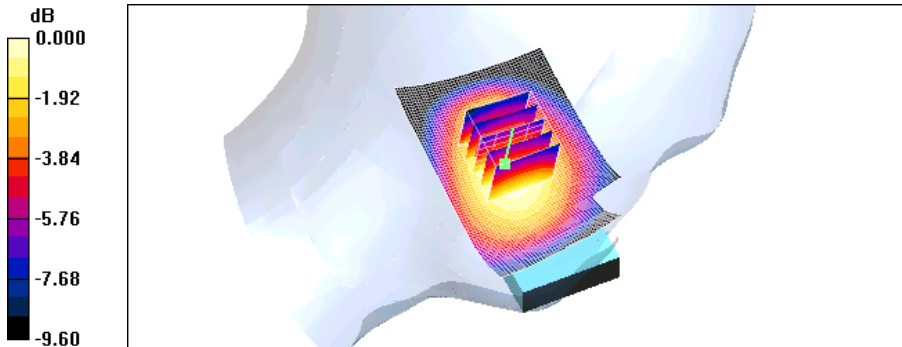

0 dB = 0.621mW/g

Test Laboratory: HCT CO., LTD
EUT Type: Cellular/PCS GSM Phone with Bluetooth
GPRS Class 10 and GPRS mode class B(GPRS and GSM, but not simultaneously)
Liquid Temperature: 21.3 °C
Ambient Temperature: 21.5 °C
Test Date: Dec.02, 2009

DUT: GX200; Type: Bar; Serial: #1

Communication System: GSM 850; Frequency: 836.6 MHz; Duty Cycle: 1:8.3
Medium parameters used (interpolated): $f = 836.6$ MHz; $\sigma = 0.898$ mho/m; $\epsilon_r = 42.1$; $\rho = 1000$ kg/m³
Phantom section: Right Section ; Measurement SW: DASY4, V4.7 Build 80; Postprocessing SW: SEMCAD, V1.8 Build 176

DASY4 Configuration:

- Probe: ET3DV6 - SN1631; ConvF(5.83, 5.83, 5.83); Calibrated: 2009-06-24
- Sensor-Surface: 4mm (Mechanical Surface Detection)
- Electronics: DAE3 Sn446; Calibrated: 2009-05-22
- Phantom: 835/900 Phantom ; Type: SAM

Right tilt 190/Area Scan (51x81x1): Measurement grid: dx=15mm, dy=15mm

[Info: Interpolated medium parameters used for SAR evaluation.](#)

Maximum value of SAR (interpolated) = 0.576 mW/g

Right tilt 190/Zoom Scan (5x5x7)/Cube 0: Measurement grid: dx=8mm, dy=8mm, dz=5mm

Reference Value = 16.3 V/m; Power Drift = -0.089 dB

Peak SAR (extrapolated) = 0.667 W/kg

SAR(1 g) = 0.543 mW/g; SAR(10 g) = 0.405 mW/g

[Info: Interpolated medium parameters used for SAR evaluation.](#)

Maximum value of SAR (measured) = 0.570 mW/g

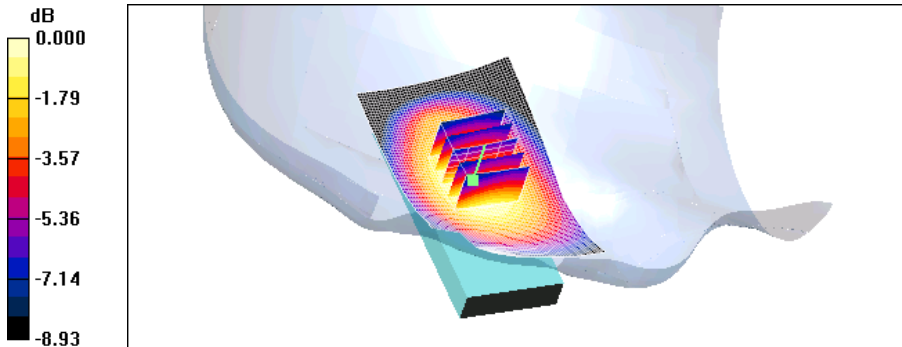

0 dB = 0.570mW/g

Test Laboratory: HCT CO., LTD
EUT Type: Cellular/PCS GSM Phone with Bluetooth
GPRS Class 10 and GPRS mode class B(GPRS and GSM, but not simultaneously)
Liquid Temperature: 21.2 °C
Ambient Temperature: 21.4 °C
Test Date: Dec.03, 2009

DUT: GX200; Type: Bar; Serial: #1

Communication System: GSM 1900; Frequency: 1850.2 MHz; Duty Cycle: 1:8.3
Medium parameters used (interpolated): $f = 1850.2$ MHz; $\sigma = 1.35$ mho/m; $\epsilon_r = 39.6$; $\rho = 1000$ kg/m³
Phantom section: Left Section ; Measurement SW: DASY4, V4.7 Build 80; Postprocessing SW: SEMCAD, V1.8 Build 176

DASY4 Configuration:

- Probe: ET3DV6 - SN1631; ConvF(5.07, 5.07, 5.07); Calibrated: 2009-06-24
- Sensor-Surface: 4mm (Mechanical Surface Detection)
- Electronics: DAE3 Sn446; Calibrated: 2009-05-22
- Phantom: 1800/1900 Phantom; Type: SAM

Left touch 512/Area Scan (51x81x1): Measurement grid: dx=15mm, dy=15mm

[Info: Interpolated medium parameters used for SAR evaluation.](#)

Maximum value of SAR (interpolated) = 0.773 mW/g

Left touch 512/Zoom Scan (5x5x7)/Cube 0: Measurement grid: dx=8mm, dy=8mm, dz=5mm

Reference Value = 8.90 V/m; Power Drift = -0.011 dB

Peak SAR (extrapolated) = 1.11 W/kg

SAR(1 g) = 0.721 mW/g; SAR(10 g) = 0.422 mW/g

[Info: Interpolated medium parameters used for SAR evaluation.](#)

Maximum value of SAR (measured) = 0.799 mW/g

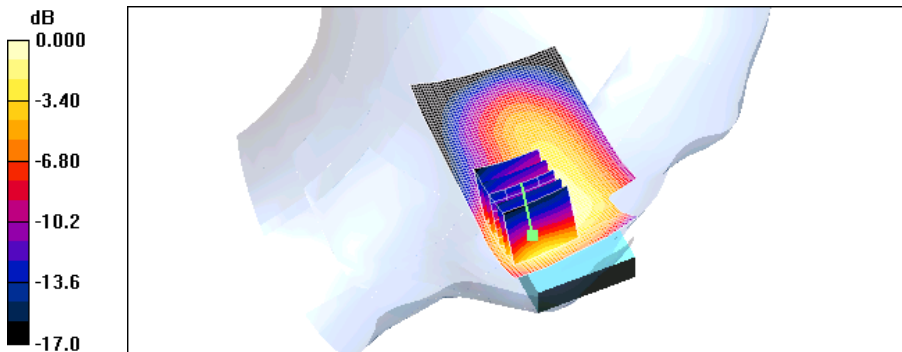

0 dB = 0.799mW/g

Test Laboratory: HCT CO., LTD
EUT Type: Cellular/PCS GSM Phone with Bluetooth
GPRS Class 10 and GPRS mode class B(GPRS and GSM, but not simultaneously)
Liquid Temperature: 21.2 °C
Ambient Temperature: 21.4 °C
Test Date: Dec.03, 2009

DUT: GX200; Type: Bar; Serial: #1

Communication System: GSM 1900; Frequency: 1880 MHz; Duty Cycle: 1:8.3
Medium parameters used: $f = 1880$ MHz; $\sigma = 1.39$ mho/m; $\epsilon_r = 39.5$; $\rho = 1000$ kg/m³
Phantom section: Left Section ; Measurement SW: DASY4, V4.7 Build 80; Postprocessing SW: SEMCAD, V1.8 Build 176

DASY4 Configuration:

- Probe: ET3DV6 - SN1631; ConvF(5.07, 5.07, 5.07); Calibrated: 2009-06-24
- Sensor-Surface: 4mm (Mechanical Surface Detection)
- Electronics: DAE3 Sn446; Calibrated: 2009-05-22
- Phantom: 1800/1900 Phantom; Type: SAM

Left touch 661/Area Scan (51x81x1): Measurement grid: dx=15mm, dy=15mm

Maximum value of SAR (interpolated) = 0.906 mW/g

Left touch 661/Zoom Scan (5x5x7)/Cube 0: Measurement grid: dx=8mm, dy=8mm, dz=5mm

Reference Value = 9.98 V/m; Power Drift = 0.003 dB

Peak SAR (extrapolated) = 1.34 W/kg

SAR(1 g) = 0.839 mW/g; SAR(10 g) = 0.489 mW/g

Maximum value of SAR (measured) = 0.924 mW/g

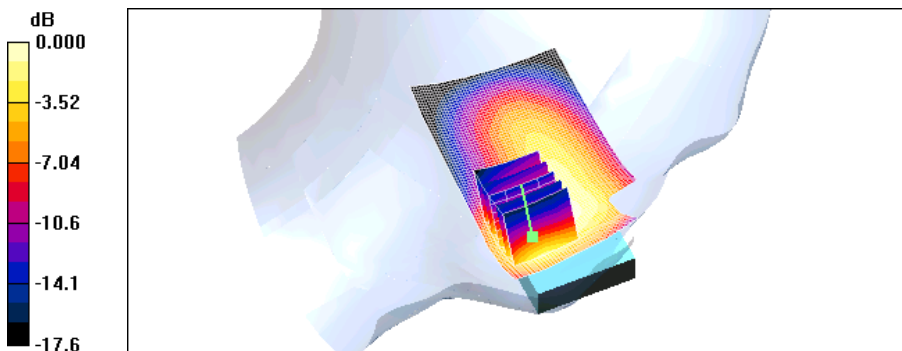

0 dB = 0.924mW/g

Test Laboratory: HCT CO., LTD
EUT Type: Cellular/PCS GSM Phone with Bluetooth
GPRS Class 10 and GPRS mode class B(GPRS and GSM, but not simultaneously)
Liquid Temperature: 21.2 °C
Ambient Temperature: 21.4 °C
Test Date: Dec.03, 2009

DUT: GX200; Type: Bar; Serial: #1

Communication System: GSM 1900; Frequency: 1909.8 MHz; Duty Cycle: 1:8.3
Medium parameters used: $f = 1910$ MHz; $\sigma = 1.43$ mho/m; $\epsilon_r = 39.4$; $\rho = 1000$ kg/m³
Phantom section: Left Section ; Measurement SW: DASY4, V4.7 Build 80; Postprocessing SW: SEMCAD, V1.8 Build 176

DASY4 Configuration:

- Probe: ET3DV6 - SN1631; ConvF(5.07, 5.07, 5.07); Calibrated: 2009-06-24
- Sensor-Surface: 4mm (Mechanical Surface Detection)
- Electronics: DAE3 Sn446; Calibrated: 2009-05-22
- Phantom: 1800/1900 Phantom; Type: SAM

Left touch 810/Area Scan (51x81x1): Measurement grid: dx=15mm, dy=15mm
Maximum value of SAR (interpolated) = 0.728 mW/g

Left touch 810/Zoom Scan (5x5x7)/Cube 0: Measurement grid: dx=8mm, dy=8mm, dz=5mm
Reference Value = 9.01 V/m; Power Drift = -0.107 dB
Peak SAR (extrapolated) = 1.14 W/kg
SAR(1 g) = 0.690 mW/g; SAR(10 g) = 0.388 mW/g
Maximum value of SAR (measured) = 0.764 mW/g

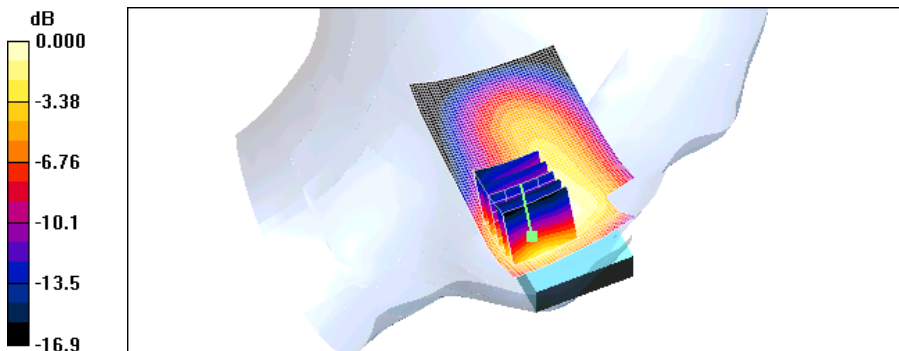

0 dB = 0.764mW/g

Test Laboratory: HCT CO., LTD
EUT Type: Cellular/PCS GSM Phone with Bluetooth
GPRS Class 10 and GPRS mode class B(GPRS and GSM, but not simultaneously)
Liquid Temperature: 21.2 °C
Ambient Temperature: 21.4 °C
Test Date: Dec.03, 2009

DUT: GX200; Type: Bar; Serial: #1

Communication System: GSM 1900; Frequency: 1850.2 MHz; Duty Cycle: 1:8.3
Medium parameters used (interpolated): $f = 1850.2$ MHz; $\sigma = 1.35$ mho/m; $\epsilon_r = 39.6$; $\rho = 1000$ kg/m³
Phantom section: Right Section ; Measurement SW: DASY4, V4.7 Build 80; Postprocessing SW: SEMCAD, V1.8 Build 176

DASY4 Configuration:

- Probe: ET3DV6 - SN1631; ConvF(5.07, 5.07, 5.07); Calibrated: 2009-06-24
- Sensor-Surface: 4mm (Mechanical Surface Detection)
- Electronics: DAE3 Sn446; Calibrated: 2009-05-22
- Phantom: 1800/1900 Phantom; Type: SAM

Right touch 512/Area Scan (51x81x1): Measurement grid: dx=15mm, dy=15mm

[Info: Interpolated medium parameters used for SAR evaluation.](#)

Maximum value of SAR (interpolated) = 0.899 mW/g

Right touch 512/Zoom Scan (5x5x7)/Cube 0: Measurement grid: dx=8mm, dy=8mm, dz=5mm

Reference Value = 9.07 V/m; Power Drift = -0.039 dB

Peak SAR (extrapolated) = 1.06 W/kg

SAR(1 g) = 0.798 mW/g; SAR(10 g) = 0.497 mW/g

[Info: Interpolated medium parameters used for SAR evaluation.](#)

Maximum value of SAR (measured) = 0.840 mW/g

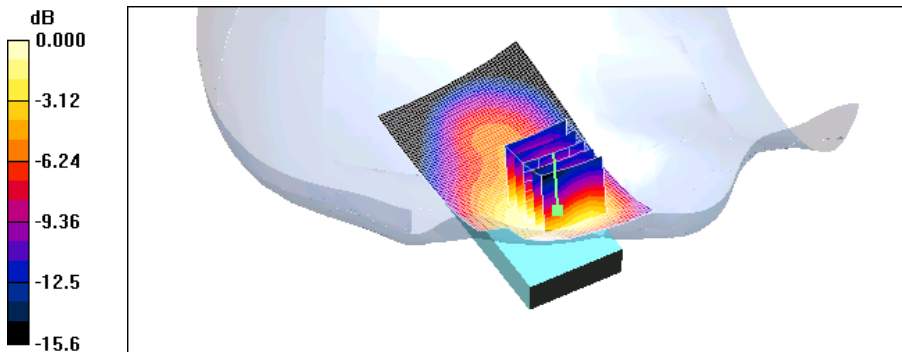

0 dB = 0.840mW/g

Test Laboratory: HCT CO., LTD
EUT Type: Cellular/PCS GSM Phone with Bluetooth
GPRS Class 10 and GPRS mode class B(GPRS and GSM, but not simultaneously)
Liquid Temperature: 21.2 °C
Ambient Temperature: 21.4 °C
Test Date: Dec.03, 2009

DUT: GX200; Type: Bar; Serial: #1

Communication System: GSM 1900; Frequency: 1880 MHz; Duty Cycle: 1:8.3
Medium parameters used: $f = 1880 \text{ MHz}$; $\sigma = 1.39 \text{ mho/m}$; $\epsilon_r = 39.5$; $\rho = 1000 \text{ kg/m}^3$
Phantom section: Right Section ; Measurement SW: DASY4, V4.7 Build 80; Postprocessing SW: SEMCAD, V1.8 Build 176

DASY4 Configuration:

- Probe: ET3DV6 - SN1631; ConvF(5.07, 5.07, 5.07); Calibrated: 2009-06-24
- Sensor-Surface: 4mm (Mechanical Surface Detection)
- Electronics: DAE3 Sn446; Calibrated: 2009-05-22
- Phantom: 1800/1900 Phantom; Type: SAM

Right touch 661/Area Scan (51x81x1): Measurement grid: dx=15mm, dy=15mm
Maximum value of SAR (interpolated) = 1.05 mW/g

Right touch 661/Zoom Scan (5x5x7)/Cube 0: Measurement grid: dx=8mm, dy=8mm, dz=5mm
Reference Value = 10.2 V/m; Power Drift = -0.044 dB
Peak SAR (extrapolated) = 1.30 W/kg
SAR(1 g) = 0.948 mW/g; SAR(10 g) = 0.578 mW/g
Maximum value of SAR (measured) = 1.000 mW/g

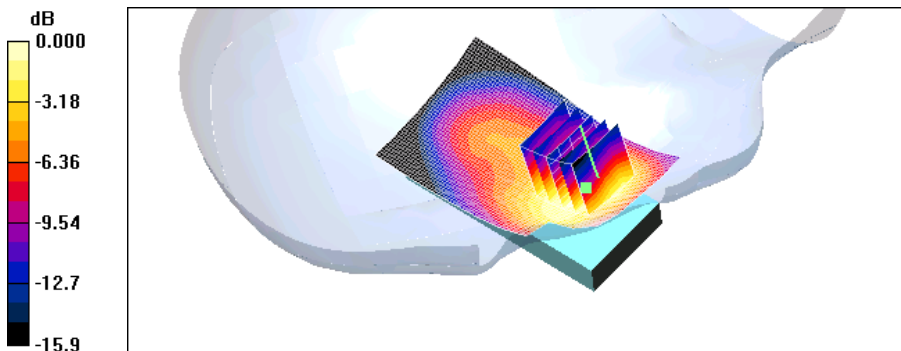

0 dB = 1.00mW/g

Test Laboratory: HCT CO., LTD
EUT Type: Cellular/PCS GSM Phone with Bluetooth
GPRS Class 10 and GPRS mode class B(GPRS and GSM, but not simultaneously)
Liquid Temperature: 21.2 °C
Ambient Temperature: 21.4 °C
Test Date: Dec.03, 2009

DUT: GX200; Type: Bar; Serial: #1

Communication System: GSM 1900; Frequency: 1909.8 MHz; Duty Cycle: 1:8.3
Medium parameters used: $f = 1910$ MHz; $\sigma = 1.43$ mho/m; $\epsilon_r = 39.4$; $\rho = 1000$ kg/m³
Phantom section: Right Section ; Measurement SW: DASY4, V4.7 Build 80; Postprocessing SW: SEMCAD, V1.8 Build 176

DASY4 Configuration:

- Probe: ET3DV6 - SN1631; ConvF(5.07, 5.07, 5.07); Calibrated: 2009-06-24
- Sensor-Surface: 4mm (Mechanical Surface Detection)
- Electronics: DAE3 Sn446; Calibrated: 2009-05-22
- Phantom: 1800/1900 Phantom; Type: SAM

Right touch 810/Area Scan (51x81x1): Measurement grid: dx=15mm, dy=15mm

Maximum value of SAR (interpolated) = 0.981 mW/g

Right touch 810/Zoom Scan (5x5x7)/Cube 0: Measurement grid: dx=8mm, dy=8mm, dz=5mm

Reference Value = 9.78 V/m; Power Drift = -0.043 dB

Peak SAR (extrapolated) = 1.21 W/kg

SAR(1 g) = 0.878 mW/g; SAR(10 g) = 0.524 mW/g

Maximum value of SAR (measured) = 0.927 mW/g

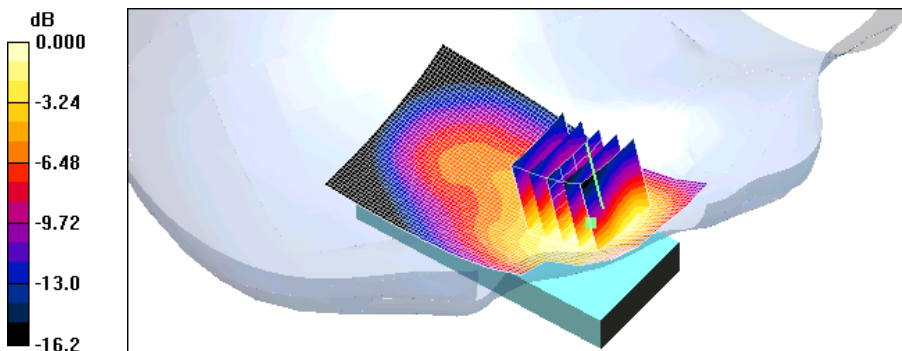

0 dB = 0.927mW/g

Test Laboratory: HCT CO., LTD
EUT Type: Cellular/PCS GSM Phone with Bluetooth
GPRS Class 10 and GPRS mode class B(GPRS and GSM, but not simultaneously)
Liquid Temperature: 21.2 °C
Ambient Temperature: 21.4 °C
Test Date: Dec.03, 2009

DUT: GX200; Type: Bar; Serial: #1

Communication System: GSM 1900; Frequency: 1850.2 MHz; Duty Cycle: 1:8.3
Medium parameters used (interpolated): $f = 1850.2$ MHz; $\sigma = 1.35$ mho/m; $\epsilon_r = 39.6$; $\rho = 1000$ kg/m³
Phantom section: Left Section ; Measurement SW: DASY4, V4.7 Build 80; Postprocessing SW: SEMCAD, V1.8 Build 176

DASY4 Configuration:

- Probe: ET3DV6 - SN1631; ConvF(5.07, 5.07, 5.07); Calibrated: 2009-06-24
- Sensor-Surface: 4mm (Mechanical Surface Detection)
- Electronics: DAE3 Sn446; Calibrated: 2009-05-22
- Phantom: 1800/1900 Phantom; Type: SAM

Left touch 512/Area Scan (51x81x1): Measurement grid: dx=15mm, dy=15mm

Info: Interpolated medium parameters used for SAR evaluation.

Maximum value of SAR (interpolated) = 0.767 mW/g

Left touch 512/Zoom Scan (5x5x7)/Cube 0: Measurement grid: dx=8mm, dy=8mm, dz=5mm

Reference Value = 7.85 V/m; Power Drift = 0.136 dB

Peak SAR (extrapolated) = 1.16 W/kg

SAR(1 g) = 0.734 mW/g; SAR(10 g) = 0.427 mW/g

Maximum value of SAR (measured) = 0.830 mW/g

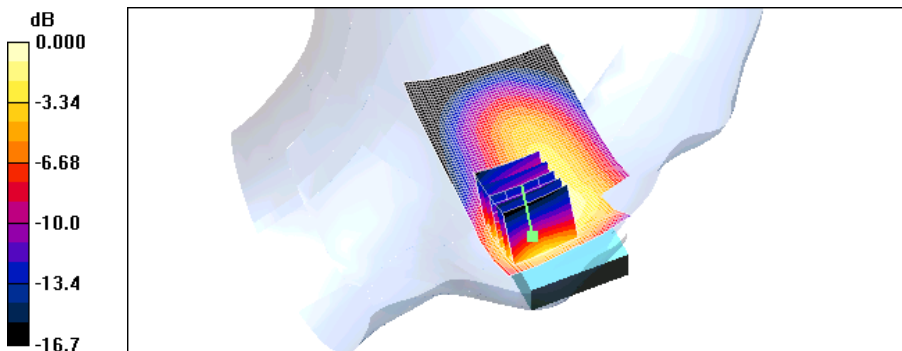

0 dB = 0.830mW/g

Test Laboratory: HCT CO., LTD
EUT Type: Cellular/PCS GSM Phone with Bluetooth
GPRS Class 10 and GPRS mode class B(GPRS and GSM, but not simultaneously)
Liquid Temperature: 21.2 °C
Ambient Temperature: 21.4 °C
Test Date: Dec.03, 2009

DUT: GX200; Type: Bar; Serial: #1

Communication System: GSM 1900; Frequency: 1880 MHz; Duty Cycle: 1:8.3
Medium parameters used: $f = 1880$ MHz; $\sigma = 1.39$ mho/m; $\epsilon_r = 39.5$; $\rho = 1000$ kg/m³
Phantom section: Left Section ; Measurement SW: DASY4, V4.7 Build 80; Postprocessing SW: SEMCAD, V1.8 Build 176

DASY4 Configuration:

- Probe: ET3DV6 - SN1631; ConvF(5.07, 5.07, 5.07); Calibrated: 2009-06-24
- Sensor-Surface: 4mm (Mechanical Surface Detection)
- Electronics: DAE3 Sn446; Calibrated: 2009-05-22
- Phantom: 1800/1900 Phantom; Type: SAM

Left touch 661/Area Scan (51x81x1): Measurement grid: dx=15mm, dy=15mm

Maximum value of SAR (interpolated) = 0.884 mW/g

Left touch 661/Zoom Scan (5x5x7)/Cube 0: Measurement grid: dx=8mm, dy=8mm, dz=5mm

Reference Value = 9.47 V/m; Power Drift = -0.445 dB

Peak SAR (extrapolated) = 1.35 W/kg

SAR(1 g) = 0.847 mW/g; SAR(10 g) = 0.492 mW/g

Maximum value of SAR (measured) = 0.922 mW/g

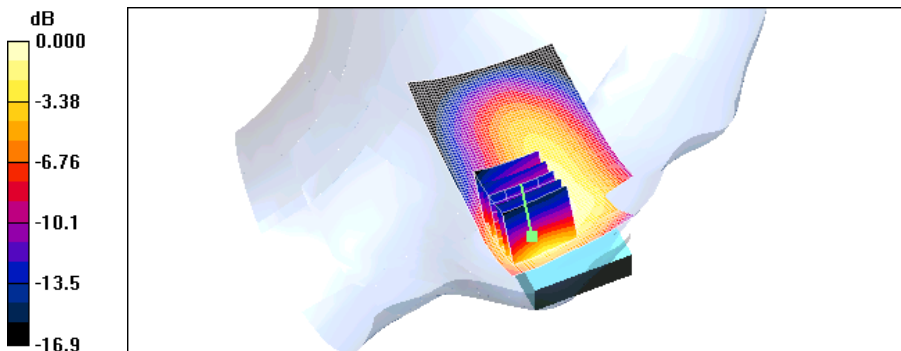

0 dB = 0.922mW/g

Test Laboratory: HCT CO., LTD
EUT Type: Cellular/PCS GSM Phone with Bluetooth
GPRS Class 10 and GPRS mode class B(GPRS and GSM, but not simultaneously)
Liquid Temperature: 21.2 °C
Ambient Temperature: 21.4 °C
Test Date: Dec.03, 2009

DUT: GX200; Type: Bar; Serial: #1

Communication System: GSM 1900; Frequency: 1909.8 MHz; Duty Cycle: 1:8.3
Medium parameters used: $f = 1910$ MHz; $\sigma = 1.43$ mho/m; $\epsilon_r = 39.4$; $\rho = 1000$ kg/m³
Phantom section: Left Section ; Measurement SW: DASY4, V4.7 Build 80; Postprocessing SW: SEMCAD, V1.8 Build 176

DASY4 Configuration:

- Probe: ET3DV6 - SN1631; ConvF(5.07, 5.07, 5.07); Calibrated: 2009-06-24
- Sensor-Surface: 4mm (Mechanical Surface Detection)
- Electronics: DAE3 Sn446; Calibrated: 2009-05-22
- Phantom: 1800/1900 Phantom; Type: SAM

Left touch 810/Area Scan (51x81x1): Measurement grid: dx=15mm, dy=15mm
Maximum value of SAR (interpolated) = 0.774 mW/g

Left touch 810/Zoom Scan (5x5x7)/Cube 0: Measurement grid: dx=8mm, dy=8mm, dz=5mm
Reference Value = 8.46 V/m; Power Drift = 0.058 dB
Peak SAR (extrapolated) = 1.27 W/kg
SAR(1 g) = 0.751 mW/g; SAR(10 g) = 0.422 mW/g
Maximum value of SAR (measured) = 0.840 mW/g

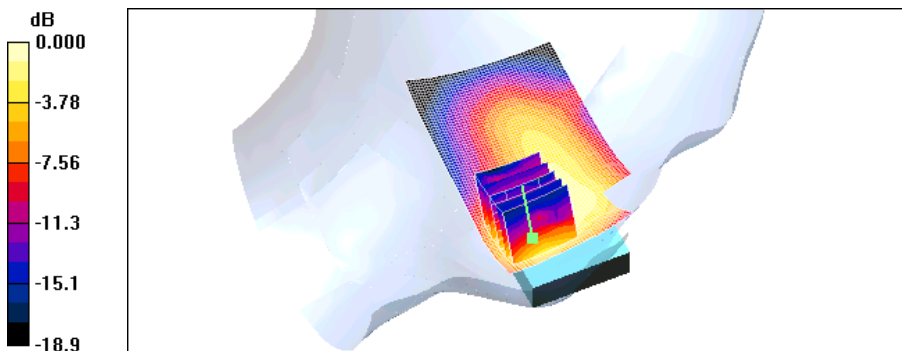

0 dB = 0.840mW/g

Test Laboratory: HCT CO., LTD
EUT Type: Cellular/PCS GSM Phone with Bluetooth
GPRS Class 10 and GPRS mode class B(GPRS and GSM, but not simultaneously)
Liquid Temperature: 21.2 °C
Ambient Temperature: 21.4 °C
Test Date: Dec.03, 2009

DUT: GX200; Type: Bar; Serial: #1

Communication System: GSM 1900; Frequency: 1850.2 MHz; Duty Cycle: 1:8.3
Medium parameters used (interpolated): $f = 1850.2$ MHz; $\sigma = 1.35$ mho/m; $\epsilon_r = 39.6$; $\rho = 1000$ kg/m³
Phantom section: Right Section ; Measurement SW: DASY4, V4.7 Build 80; Postprocessing SW: SEMCAD, V1.8 Build 176

DASY4 Configuration:

- Probe: ET3DV6 - SN1631; ConvF(5.07, 5.07, 5.07); Calibrated: 2009-06-24
- Sensor-Surface: 4mm (Mechanical Surface Detection)
- Electronics: DAE3 Sn446; Calibrated: 2009-05-22
- Phantom: 1800/1900 Phantom; Type: SAM

Right touch 512/Area Scan (51x81x1): Measurement grid: dx=15mm, dy=15mm

[Info: Interpolated medium parameters used for SAR evaluation.](#)

Maximum value of SAR (interpolated) = 0.915 mW/g

Right touch 512/Zoom Scan (5x5x7)/Cube 0: Measurement grid: dx=8mm, dy=8mm, dz=5mm

Reference Value = 9.70 V/m; Power Drift = -0.042 dB

Peak SAR (extrapolated) = 1.09 W/kg

SAR(1 g) = 0.809 mW/g; SAR(10 g) = 0.501 mW/g

[Info: Interpolated medium parameters used for SAR evaluation.](#)

Maximum value of SAR (measured) = 0.855 mW/g

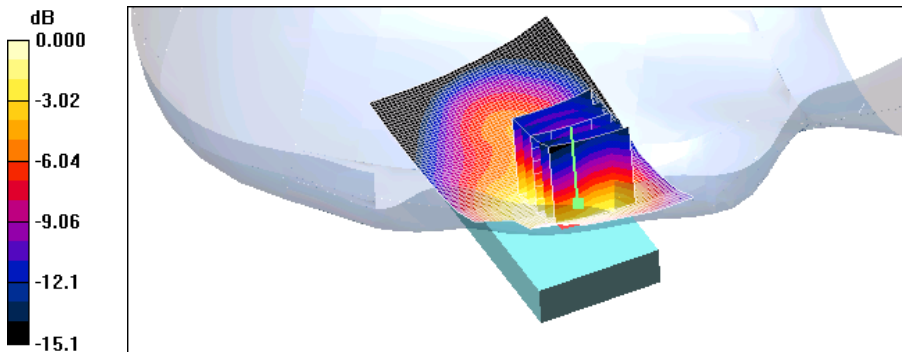

0 dB = 0.855mW/g

Test Laboratory: HCT CO., LTD
EUT Type: Cellular/PCS GSM Phone with Bluetooth
GPRS Class 10 and GPRS mode class B(GPRS and GSM, but not simultaneously)
Liquid Temperature: 21.2 °C
Ambient Temperature: 21.4 °C
Test Date: Dec.03, 2009

DUT: GX200; Type: Bar; Serial: #1

Communication System: GSM 1900; Frequency: 1880 MHz; Duty Cycle: 1:8.3
Medium parameters used: $f = 1880$ MHz; $\sigma = 1.39$ mho/m; $\epsilon_r = 39.5$; $\rho = 1000$ kg/m³
Phantom section: Right Section ; Measurement SW: DASY4, V4.7 Build 80; Postprocessing SW: SEMCAD, V1.8 Build 176

DASY4 Configuration:

- Probe: ET3DV6 - SN1631; ConvF(5.07, 5.07, 5.07); Calibrated: 2009-06-24
- Sensor-Surface: 4mm (Mechanical Surface Detection)
- Electronics: DAE3 Sn446; Calibrated: 2009-05-22
- Phantom: 1800/1900 Phantom; Type: SAM

Right touch 661/Area Scan (51x81x1): Measurement grid: dx=15mm, dy=15mm

Maximum value of SAR (interpolated) = 1.05 mW/g

Right touch 661/Zoom Scan (5x5x7)/Cube 0: Measurement grid: dx=8mm, dy=8mm, dz=5mm

Reference Value = 11.0 V/m; Power Drift = 0.027 dB

Peak SAR (extrapolated) = 1.30 W/kg

SAR(1 g) = 0.949 mW/g; SAR(10 g) = 0.578 mW/g

Maximum value of SAR (measured) = 0.997 mW/g

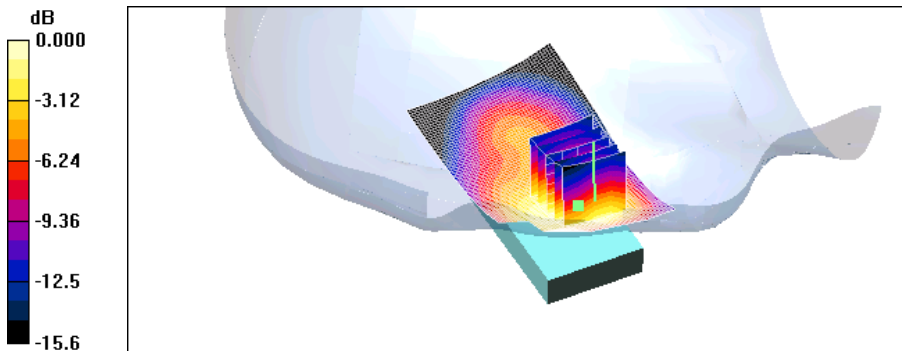

0 dB = 0.997mW/g

Test Laboratory: HCT CO., LTD
EUT Type: Cellular/PCS GSM Phone with Bluetooth
GPRS Class 10 and GPRS mode class B(GPRS and GSM, but not simultaneously)
Liquid Temperature: 21.2 °C
Ambient Temperature: 21.4 °C
Test Date: Dec.03, 2009

DUT: GX200; Type: Bar; Serial: #1

Communication System: GSM 1900; Frequency: 1909.8 MHz; Duty Cycle: 1:8.3
Medium parameters used: $f = 1910$ MHz; $\sigma = 1.43$ mho/m; $\epsilon_r = 39.4$; $\rho = 1000$ kg/m³
Phantom section: Right Section ; Measurement SW: DASY4, V4.7 Build 80; Postprocessing SW: SEMCAD, V1.8 Build 176

DASY4 Configuration:

- Probe: ET3DV6 - SN1631; ConvF(5.07, 5.07, 5.07); Calibrated: 2009-06-24
- Sensor-Surface: 4mm (Mechanical Surface Detection)
- Electronics: DAE3 Sn446; Calibrated: 2009-05-22
- Phantom: 1800/1900 Phantom; Type: SAM

Right touch 810/Area Scan (51x81x1): Measurement grid: dx=15mm, dy=15mm

Maximum value of SAR (interpolated) = 1.04 mW/g

Right touch 810/Zoom Scan (5x5x7)/Cube 0: Measurement grid: dx=8mm, dy=8mm, dz=5mm

Reference Value = 10.7 V/m; Power Drift = -0.129 dB

Peak SAR (extrapolated) = 1.26 W/kg

SAR(1 g) = 0.913 mW/g; SAR(10 g) = 0.547 mW/g

Maximum value of SAR (measured) = 0.959 mW/g

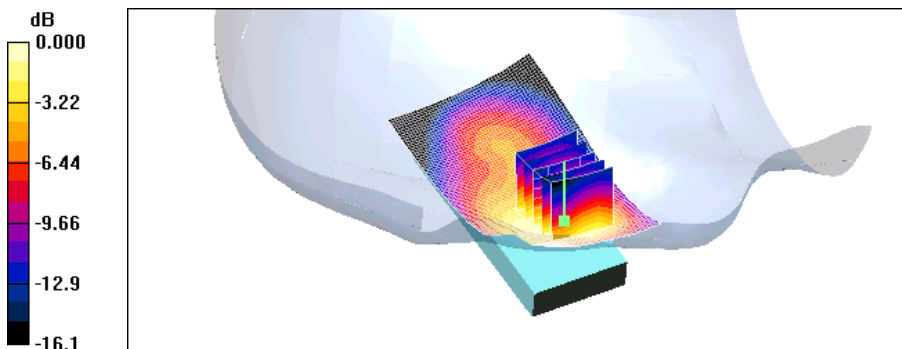

0 dB = 0.959mW/g

Test Laboratory: HCT CO., LTD
EUT Type: Cellular/PCS GSM Phone with Bluetooth
GPRS Class 10 and GPRS mode class B(GPRS and GSM, but not simultaneously)
Liquid Temperature: 21.2 °C
Ambient Temperature: 21.4 °C
Test Date: Dec.03, 2009

DUT: GX200; Type: Bar; Serial: #1

Communication System: GSM 1900; Frequency: 1880 MHz; Duty Cycle: 1:8.3
Medium parameters used: $f = 1880$ MHz; $\sigma = 1.39$ mho/m; $\epsilon_r = 39.5$; $\rho = 1000$ kg/m³
Phantom section: Left Section ; Measurement SW: DASY4, V4.7 Build 80; Postprocessing SW: SEMCAD, V1.8 Build 176

DASY4 Configuration:

- Probe: ET3DV6 - SN1631; ConvF(5.07, 5.07, 5.07); Calibrated: 2009-06-24
- Sensor-Surface: 4mm (Mechanical Surface Detection)
- Electronics: DAE3 Sn446; Calibrated: 2009-05-22
- Phantom: 1800/1900 Phantom; Type: SAM

Left tilt 661/Area Scan (51x81x1): Measurement grid: dx=15mm, dy=15mm

Maximum value of SAR (interpolated) = 0.425 mW/g

Left tilt 661/Zoom Scan (5x5x7)/Cube 0: Measurement grid: dx=8mm, dy=8mm, dz=5mm

Reference Value = 13.4 V/m; Power Drift = -0.044 dB

Peak SAR (extrapolated) = 0.519 W/kg

SAR(1 g) = 0.389 mW/g; SAR(10 g) = 0.241 mW/g

Maximum value of SAR (measured) = 0.429 mW/g

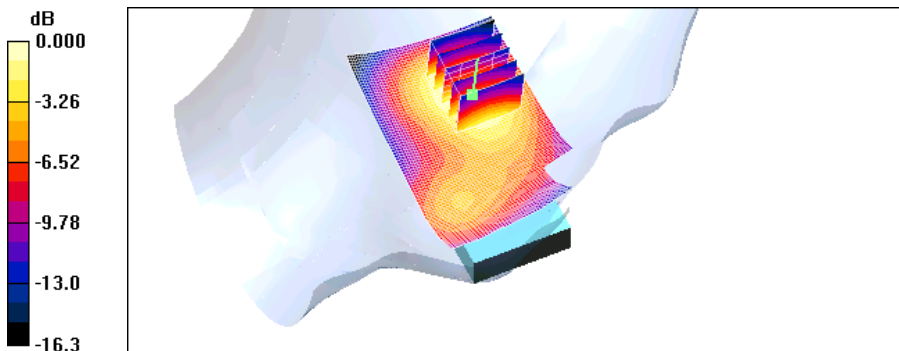

0 dB = 0.429mW/g

Test Laboratory: HCT CO., LTD
EUT Type: Cellular/PCS GSM Phone with Bluetooth
GPRS Class 10 and GPRS mode class B(GPRS and GSM, but not simultaneously)
Liquid Temperature: 21.2 °C
Ambient Temperature: 21.4 °C
Test Date: Dec.03, 2009

DUT: GX200; Type: Bar; Serial: #1

Communication System: GSM 1900; Frequency: 1880 MHz; Duty Cycle: 1:8.3
Medium parameters used: $f = 1880$ MHz; $\sigma = 1.39$ mho/m; $\epsilon_r = 39.5$; $\rho = 1000$ kg/m³
Phantom section: Right Section ; Measurement SW: DASY4, V4.7 Build 80; Postprocessing SW: SEMCAD, V1.8 Build 176

DASY4 Configuration:

- Probe: ET3DV6 - SN1631; ConvF(5.07, 5.07, 5.07); Calibrated: 2009-06-24
- Sensor-Surface: 4mm (Mechanical Surface Detection)
- Electronics: DAE3 Sn446; Calibrated: 2009-05-22
- Phantom: 1800/1900 Phantom; Type: SAM

Right tilt 661/Area Scan (51x81x1): Measurement grid: dx=15mm, dy=15mm

Maximum value of SAR (interpolated) = 0.323 mW/g

Right tilt 661/Zoom Scan (5x5x7)/Cube 0: Measurement grid: dx=8mm, dy=8mm, dz=5mm

Reference Value = 13.3 V/m; Power Drift = -0.004 dB

Peak SAR (extrapolated) = 0.378 W/kg

SAR(1 g) = 0.288 mW/g; SAR(10 g) = 0.182 mW/g

Maximum value of SAR (measured) = 0.310 mW/g

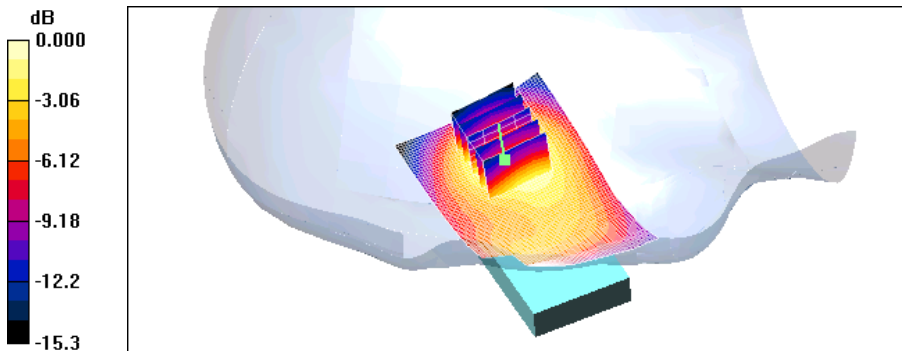

0 dB = 0.310mW/g

Test Laboratory: HCT CO., LTD
EUT Type: Cellular/PCS GSM Phone with Bluetooth
GPRS Class 10 and GPRS mode class B(GPRS and GSM, but not simultaneously)
Liquid Temperature: 21.2 °C
Ambient Temperature: 21.4 °C
Test Date: Dec.03, 2009

DUT: GX200; Type: Bar; Serial: #1

Communication System: GSM 1900; Frequency: 1880 MHz; Duty Cycle: 1:8.3
Medium parameters used: $f = 1880$ MHz; $\sigma = 1.39$ mho/m; $\epsilon_r = 39.5$; $\rho = 1000$ kg/m³
Phantom section: Left Section ; Measurement SW: DASY4, V4.7 Build 80; Postprocessing SW: SEMCAD, V1.8 Build 176

DASY4 Configuration:

- Probe: ET3DV6 - SN1631; ConvF(5.07, 5.07, 5.07); Calibrated: 2009-06-24
- Sensor-Surface: 4mm (Mechanical Surface Detection)
- Electronics: DAE3 Sn446; Calibrated: 2009-05-22
- Phantom: 1800/1900 Phantom; Type: SAM

Left tilt 661/Area Scan (51x81x1): Measurement grid: dx=15mm, dy=15mm

Maximum value of SAR (interpolated) = 0.408 mW/g

Left tilt 661/Zoom Scan (5x5x7)/Cube 0: Measurement grid: dx=8mm, dy=8mm, dz=5mm

Reference Value = 11.8 V/m; Power Drift = 0.023 dB

Peak SAR (extrapolated) = 0.614 W/kg

SAR(1 g) = 0.378 mW/g; SAR(10 g) = 0.230 mW/g

Maximum value of SAR (measured) = 0.431 mW/g

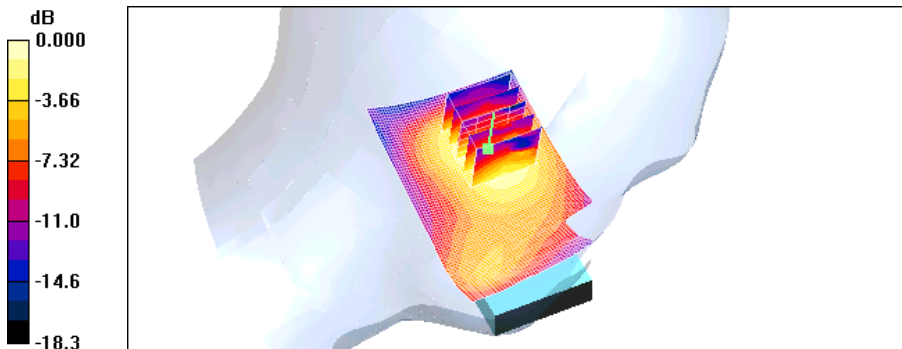

0 dB = 0.431mW/g

Test Laboratory: HCT CO., LTD
EUT Type: Cellular/PCS GSM Phone with Bluetooth
GPRS Class 10 and GPRS mode class B(GPRS and GSM, but not simultaneously)
Liquid Temperature: 21.2 °C
Ambient Temperature: 21.4 °C
Test Date: Dec.03, 2009

DUT: GX200; Type: Bar; Serial: #1

Communication System: GSM 1900; Frequency: 1880 MHz; Duty Cycle: 1:8.3
Medium parameters used: $f = 1880$ MHz; $\sigma = 1.39$ mho/m; $\epsilon_r = 39.5$; $\rho = 1000$ kg/m³
Phantom section: Right Section ; Measurement SW: DASY4, V4.7 Build 80; Postprocessing SW: SEMCAD, V1.8 Build 176

DASY4 Configuration:

- Probe: ET3DV6 - SN1631; ConvF(5.07, 5.07, 5.07); Calibrated: 2009-06-24
- Sensor-Surface: 4mm (Mechanical Surface Detection)
- Electronics: DAE3 Sn446; Calibrated: 2009-05-22
- Phantom: 1800/1900 Phantom; Type: SAM

Right tilt 661/Area Scan (51x81x1): Measurement grid: dx=15mm, dy=15mm

Maximum value of SAR (interpolated) = 0.348 mW/g

Right tilt 661/Zoom Scan (5x5x7)/Cube 0: Measurement grid: dx=8mm, dy=8mm, dz=5mm

Reference Value = 14.3 V/m; Power Drift = -0.012 dB

Peak SAR (extrapolated) = 0.407 W/kg

SAR(1 g) = 0.311 mW/g; SAR(10 g) = 0.196 mW/g

Maximum value of SAR (measured) = 0.334 mW/g

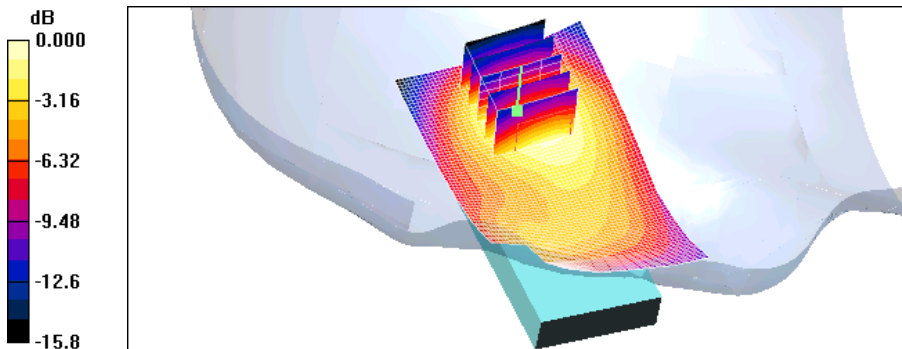

0 dB = 0.334mW/g

Test Laboratory: HCT CO., LTD
EUT Type: Cellular/PCS GSM Phone with Bluetooth
GPRS Class 10 and GPRS mode class B(GPRS and GSM, but not simultaneously)
Liquid Temperature: 21.3 °C
Ambient Temperature: 21.5 °C
Test Date: Dec.02, 2009

DUT: GX200; Type: Bar; Serial: #1

Communication System: GSM 850; Frequency: 824.2 MHz; Duty Cycle: 1:8.3
Medium parameters used: $f = 825$ MHz; $\sigma = 0.931$ mho/m; $\epsilon_r = 54.9$; $\rho = 1000$ kg/m³
Phantom section: Flat Section ; Measurement SW: DASY4, V4.7 Build 80; Postprocessing SW: SEMCAD, V1.8 Build 176

DASY4 Configuration:

- Probe: ET3DV6 - SN1631; ConvF(5.91, 5.91, 5.91); Calibrated: 2009-06-24
- Sensor-Surface: 4mm (Mechanical Surface Detection)
- Electronics: DAE3 Sn446; Calibrated: 2009-05-22
- Phantom: 835/900 Phantom ; Type: SAM

GSM Body 128/Area Scan (51x91x1): Measurement grid: dx=15mm, dy=15mm

Maximum value of SAR (interpolated) = 0.588 mW/g

GSM Body 128/Zoom Scan (5x5x7)/Cube 0: Measurement grid: dx=8mm, dy=8mm, dz=5mm

Reference Value = 13.2 V/m; Power Drift = -0.046 dB

Peak SAR (extrapolated) = 0.708 W/kg

SAR(1 g) = 0.558 mW/g; SAR(10 g) = 0.408 mW/g

Maximum value of SAR (measured) = 0.587 mW/g

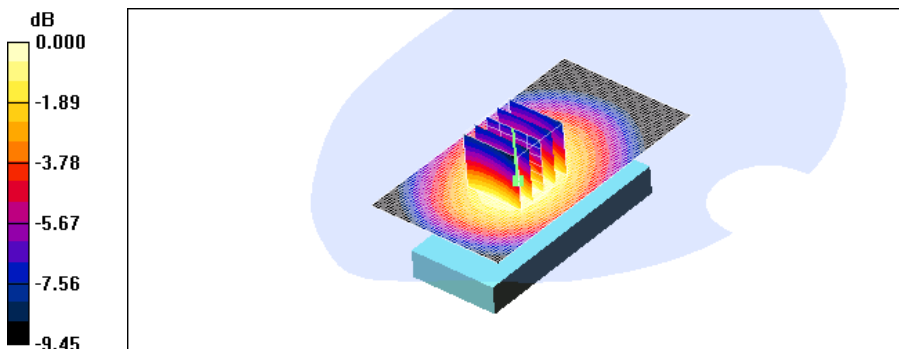

0 dB = 0.587mW/g

Test Laboratory: HCT CO., LTD
EUT Type: Cellular/PCS GSM Phone with Bluetooth
GPRS Class 10 and GPRS mode class B(GPRS and GSM, but not simultaneously)
Liquid Temperature: 21.3 °C
Ambient Temperature: 21.5 °C
Test Date: Dec.02, 2009

DUT: GX200; Type: Bar; Serial: #1

Communication System: GSM 850; Frequency: 824.2 MHz; Duty Cycle: 1:4.15
Medium parameters used: $f = 825$ MHz; $\sigma = 0.931$ mho/m; $\epsilon_r = 54.9$; $\rho = 1000$ kg/m³
Phantom section: Flat Section ; Measurement SW: DASY4, V4.7 Build 80; Postprocessing SW: SEMCAD, V1.8 Build 176

DASY4 Configuration:

- Probe: ET3DV6 - SN1631; ConvF(5.91, 5.91, 5.91); Calibrated: 2009-06-24
- Sensor-Surface: 4mm (Mechanical Surface Detection)
- Electronics: DAE3 Sn446; Calibrated: 2009-05-22
- Phantom: 835/900 Phantom ; Type: SAM

GSM Body 128/Area Scan (51x91x1): Measurement grid: dx=15mm, dy=15mm

Maximum value of SAR (interpolated) = 1.16 mW/g

GSM Body 128/Zoom Scan (5x5x7)/Cube 0: Measurement grid: dx=8mm, dy=8mm, dz=5mm

Reference Value = 19.2 V/m; Power Drift = -0.122 dB

Peak SAR (extrapolated) = 1.38 W/kg

SAR(1 g) = 1.09 mW/g; SAR(10 g) = 0.804 mW/g

Maximum value of SAR (measured) = 1.15 mW/g

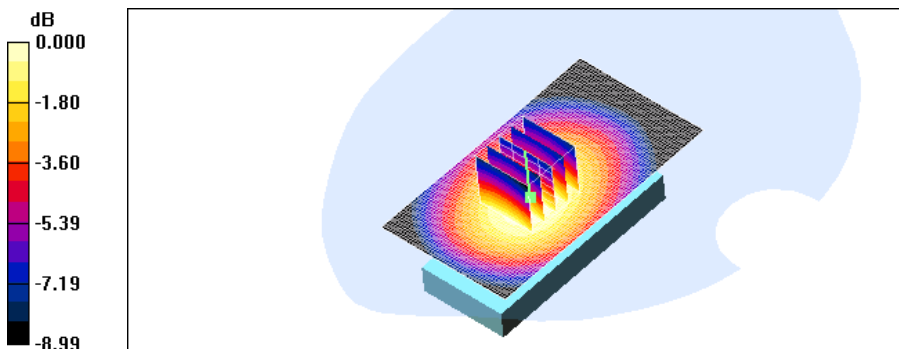

0 dB = 1.15mW/g

Test Laboratory: HCT CO., LTD
EUT Type: Cellular/PCS GSM Phone with Bluetooth
GPRS Class 10 and GPRS mode class B(GPRS and GSM, but not simultaneously)
Liquid Temperature: 21.3 °C
Ambient Temperature: 21.5 °C
Test Date: Dec.02, 2009

DUT: GX200; Type: Bar; Serial: #1

Communication System: GSM 850; Frequency: 836.6 MHz; Duty Cycle: 1:4.15
Medium parameters used (interpolated): $f = 836.6$ MHz; $\sigma = 0.941$ mho/m; $\epsilon_r = 54.9$; $\rho = 1000$ kg/m³
Phantom section: Flat Section ; Measurement SW: DASY4, V4.7 Build 80; Postprocessing SW: SEMCAD, V1.8 Build 176

DASY4 Configuration:

- Probe: ET3DV6 - SN1631; ConvF(5.91, 5.91, 5.91); Calibrated: 2009-06-24
- Sensor-Surface: 4mm (Mechanical Surface Detection)
- Electronics: DAE3 Sn446; Calibrated: 2009-05-22
- Phantom: 835/900 Phantom ; Type: SAM

GSM Body 190/Area Scan (51x91x1): Measurement grid: dx=15mm, dy=15mm

[Info: Interpolated medium parameters used for SAR evaluation.](#)

Maximum value of SAR (interpolated) = 1.02 mW/g

GSM Body 190/Zoom Scan (5x5x7)/Cube 0: Measurement grid: dx=8mm, dy=8mm, dz=5mm

Reference Value = 17.9 V/m; Power Drift = 0.107 dB

Peak SAR (extrapolated) = 1.22 W/kg

SAR(1 g) = 0.962 mW/g; SAR(10 g) = 0.704 mW/g

[Info: Interpolated medium parameters used for SAR evaluation.](#)

Maximum value of SAR (measured) = 1.01 mW/g

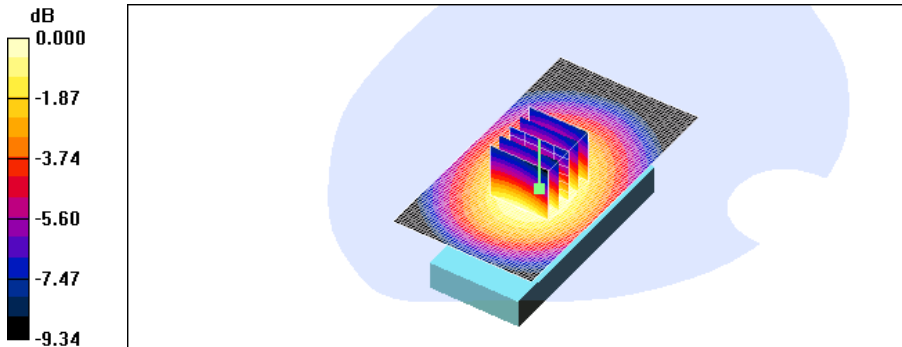

0 dB = 1.01mW/g

Test Laboratory: HCT CO., LTD
EUT Type: Cellular/PCS GSM Phone with Bluetooth
GPRS Class 10 and GPRS mode class B(GPRS and GSM, but not simultaneously)
Liquid Temperature: 21.3 °C
Ambient Temperature: 21.5 °C
Test Date: Dec.02, 2009

DUT: GX200; Type: Bar; Serial: #1

Communication System: GSM 850; Frequency: 848.8 MHz; Duty Cycle: 1:4.15
Medium parameters used (interpolated): $f = 848.8 \text{ MHz}$; $\sigma = 0.953 \text{ mho/m}$; $\epsilon_r = 54.9$; $\rho = 1000 \text{ kg/m}^3$
Phantom section: Flat Section ; Measurement SW: DASY4, V4.7 Build 80; Postprocessing SW: SEMCAD, V1.8 Build 176

DASY4 Configuration:

- Probe: ET3DV6 - SN1631; ConvF(5.91, 5.91, 5.91); Calibrated: 2009-06-24
- Sensor-Surface: 4mm (Mechanical Surface Detection)
- Electronics: DAE3 Sn446; Calibrated: 2009-05-22
- Phantom: 835/900 Phantom ; Type: SAM

GSM Body 251/Area Scan (51x91x1): Measurement grid: dx=15mm, dy=15mm

[Info: Interpolated medium parameters used for SAR evaluation.](#)

Maximum value of SAR (interpolated) = 0.939 mW/g

GSM Body 251/Zoom Scan (5x5x7)/Cube 0: Measurement grid: dx=8mm, dy=8mm, dz=5mm

Reference Value = 17.0 V/m; Power Drift = 0.032 dB

Peak SAR (extrapolated) = 1.12 W/kg

SAR(1 g) = 0.889 mW/g; SAR(10 g) = 0.647 mW/g

[Info: Interpolated medium parameters used for SAR evaluation.](#)

Maximum value of SAR (measured) = 0.943 mW/g

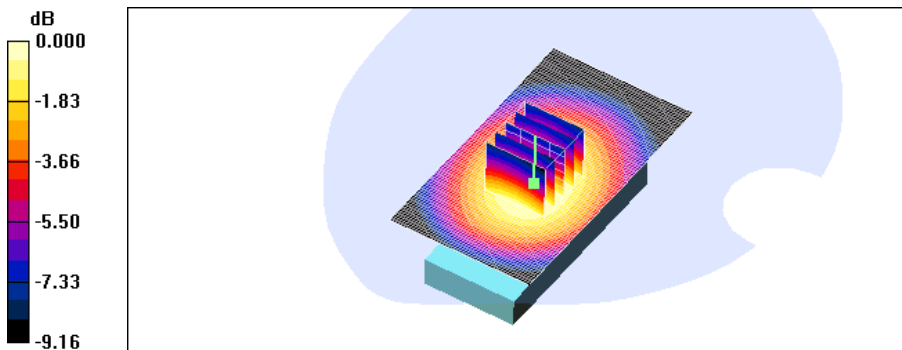

0 dB = 0.943mW/g

Test Laboratory: HCT CO., LTD
EUT Type: Cellular/PCS GSM Phone with Bluetooth
GPRS Class 10 and GPRS mode class B(GPRS and GSM, but not simultaneously)
Liquid Temperature: 21.3 °C
Ambient Temperature: 21.5 °C
Test Date: Dec.02, 2009

DUT: GX200; Type: Bar; Serial: #1

Communication System: GSM 850; Frequency: 824.2 MHz; Duty Cycle: 1:4.15
Medium parameters used: $f = 825$ MHz; $\sigma = 0.931$ mho/m; $\epsilon_r = 54.9$; $\rho = 1000$ kg/m³
Phantom section: Flat Section ; Measurement SW: DASY4, V4.7 Build 80; Postprocessing SW: SEMCAD, V1.8 Build 176

DASY4 Configuration:

- Probe: ET3DV6 - SN1631; ConvF(5.91, 5.91, 5.91); Calibrated: 2009-06-24
- Sensor-Surface: 4mm (Mechanical Surface Detection)
- Electronics: DAE3 Sn446; Calibrated: 2009-05-22
- Phantom: 835/900 Phantom ; Type: SAM

GSM Body 128/Area Scan (51x91x1): Measurement grid: dx=15mm, dy=15mm

Maximum value of SAR (interpolated) = 0.735 mW/g

GSM Body 128/Zoom Scan (5x5x7)/Cube 0: Measurement grid: dx=8mm, dy=8mm, dz=5mm

Reference Value = 16.1 V/m; Power Drift = -0.071 dB

Peak SAR (extrapolated) = 0.873 W/kg

SAR(1 g) = 0.696 mW/g; SAR(10 g) = 0.513 mW/g

Maximum value of SAR (measured) = 0.738 mW/g

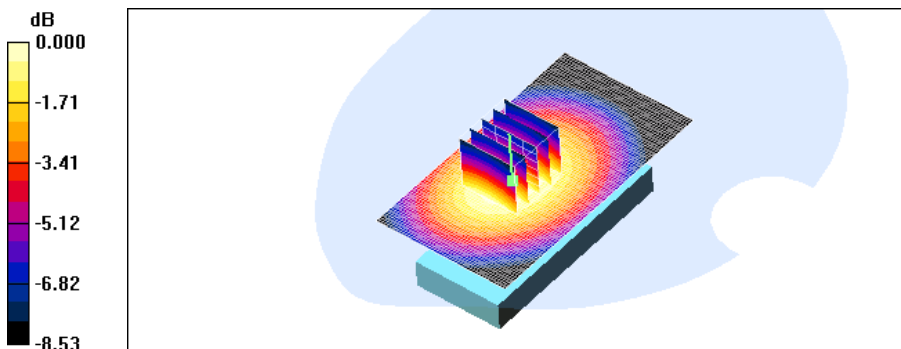

0 dB = 0.738mW/g

Test Laboratory: HCT CO., LTD
EUT Type: Cellular/PCS GSM Phone with Bluetooth
GPRS Class 10 and GPRS mode class B(GPRS and GSM, but not simultaneously)
Liquid Temperature: 21.3 °C
Ambient Temperature: 21.5 °C
Test Date: Dec.02, 2009

DUT: GX200; Type: Bar; Serial: #1

Communication System: GSM 850; Frequency: 824.2 MHz; Duty Cycle: 1:8.3
Medium parameters used: $f = 825$ MHz; $\sigma = 0.931$ mho/m; $\epsilon_r = 54.9$; $\rho = 1000$ kg/m³
Phantom section: Flat Section ; Measurement SW: DASY4, V4.7 Build 80; Postprocessing SW: SEMCAD, V1.8 Build 176

DASY4 Configuration:

- Probe: ET3DV6 - SN1631; ConvF(5.91, 5.91, 5.91); Calibrated: 2009-06-24
- Sensor-Surface: 4mm (Mechanical Surface Detection)
- Electronics: DAE3 Sn446; Calibrated: 2009-05-22
- Phantom: 835/900 Phantom ; Type: SAM

GSM Body 128/Area Scan (51x91x1): Measurement grid: dx=15mm, dy=15mm

Maximum value of SAR (interpolated) = 0.584 mW/g

GSM Body 128/Zoom Scan (5x5x7)/Cube 0: Measurement grid: dx=8mm, dy=8mm, dz=5mm

Reference Value = 13.2 V/m; Power Drift = 0.060 dB

Peak SAR (extrapolated) = 0.711 W/kg

SAR(1 g) = 0.557 mW/g; SAR(10 g) = 0.406 mW/g

Maximum value of SAR (measured) = 0.590 mW/g

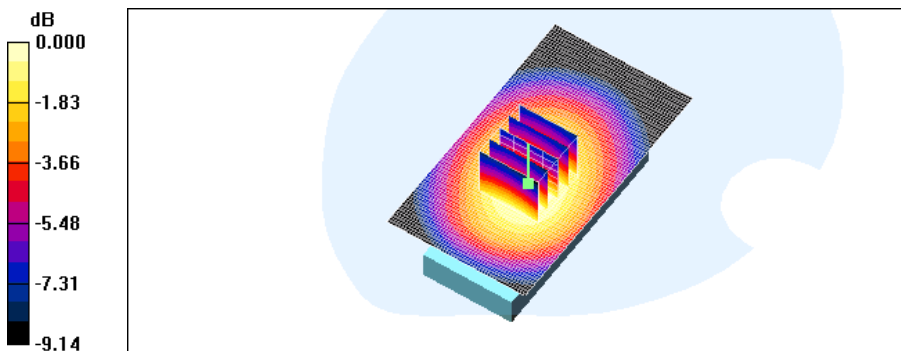

0 dB = 0.590mW/g

Test Laboratory: HCT CO., LTD
EUT Type: Cellular/PCS GSM Phone with Bluetooth
GPRS Class 10 and GPRS mode class B(GPRS and GSM, but not simultaneously)
Liquid Temperature: 21.3 °C
Ambient Temperature: 21.5 °C
Test Date: Dec.02, 2009

DUT: GX200; Type: Bar; Serial: #1

Communication System: GSM 850; Frequency: 824.2 MHz; Duty Cycle: 1:8.3
Medium parameters used: $f = 825$ MHz; $\sigma = 0.931$ mho/m; $\epsilon_r = 54.9$; $\rho = 1000$ kg/m³
Phantom section: Flat Section ; Measurement SW: DASY4, V4.7 Build 80; Postprocessing SW: SEMCAD, V1.8 Build 176

DASY4 Configuration:

- Probe: ET3DV6 - SN1631; ConvF(5.91, 5.91, 5.91); Calibrated: 2009-06-24
- Sensor-Surface: 4mm (Mechanical Surface Detection)
- Electronics: DAE3 Sn446; Calibrated: 2009-05-22
- Phantom: 835/900 Phantom ; Type: SAM

GSM Body 128/Area Scan (51x91x1): Measurement grid: dx=15mm, dy=15mm
Maximum value of SAR (interpolated) = 0.529 mW/g

GSM Body 128/Zoom Scan (5x5x7)/Cube 0: Measurement grid: dx=8mm, dy=8mm, dz=5mm
Reference Value = 13.5 V/m; Power Drift = -0.009 dB
Peak SAR (extrapolated) = 0.641 W/kg
SAR(1 g) = 0.504 mW/g; SAR(10 g) = 0.370 mW/g
Maximum value of SAR (measured) = 0.534 mW/g

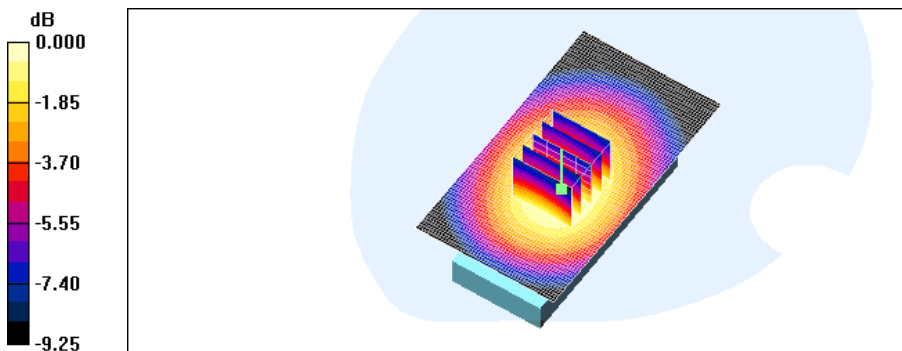

0 dB = 0.534mW/g

Test Laboratory: HCT CO., LTD
EUT Type: Cellular/PCS GSM Phone with Bluetooth
GPRS Class 10 and GPRS mode class B(GPRS and GSM, but not simultaneously)
Liquid Temperature: 21.3 °C
Ambient Temperature: 21.5 °C
Test Date: Dec.02, 2009

DUT: GX200; Type: Bar; Serial: #1

Communication System: GSM 850; Frequency: 824.2 MHz; Duty Cycle: 1:4.15
Medium parameters used: $f = 825$ MHz; $\sigma = 0.931$ mho/m; $\epsilon_r = 54.9$; $\rho = 1000$ kg/m³
Phantom section: Flat Section ; Measurement SW: DASY4, V4.7 Build 80; Postprocessing SW: SEMCAD, V1.8 Build 176

DASY4 Configuration:

- Probe: ET3DV6 - SN1631; ConvF(5.91, 5.91, 5.91); Calibrated: 2009-06-24
- Sensor-Surface: 4mm (Mechanical Surface Detection)
- Electronics: DAE3 Sn446; Calibrated: 2009-05-22
- Phantom: 835/900 Phantom ; Type: SAM

GSM Body 128/Area Scan (51x91x1): Measurement grid: dx=15mm, dy=15mm

Maximum value of SAR (interpolated) = 1.06 mW/g

GSM Body 128/Zoom Scan (5x5x7)/Cube 0: Measurement grid: dx=8mm, dy=8mm, dz=5mm

Reference Value = 19.1 V/m; Power Drift = -0.097 dB

Peak SAR (extrapolated) = 1.26 W/kg

SAR(1 g) = 0.994 mW/g; SAR(10 g) = 0.731 mW/g

Maximum value of SAR (measured) = 1.04 mW/g

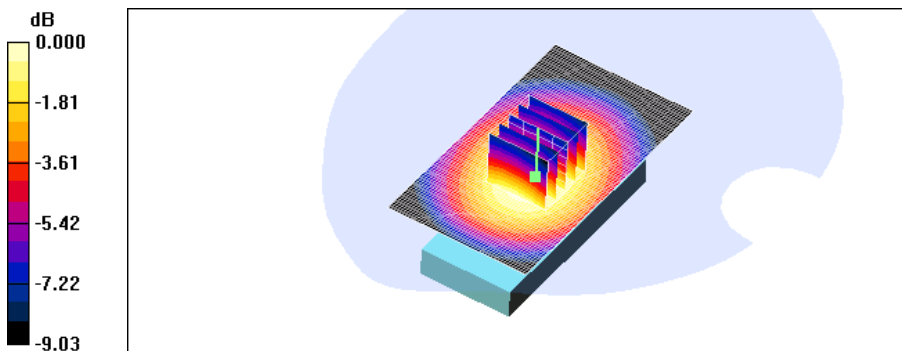

0 dB = 1.04mW/g

Test Laboratory: HCT CO., LTD
EUT Type: Cellular/PCS GSM Phone with Bluetooth
GPRS Class 10 and GPRS mode class B(GPRS and GSM, but not simultaneously)
Liquid Temperature: 21.3 °C
Ambient Temperature: 21.5 °C
Test Date: Dec.02, 2009

DUT: GX200; Type: Bar; Serial: #1

Communication System: GSM 850; Frequency: 836.6 MHz; Duty Cycle: 1:4.15
Medium parameters used (interpolated): $f = 836.6$ MHz; $\sigma = 0.941$ mho/m; $\epsilon_r = 54.9$; $\rho = 1000$ kg/m³
Phantom section: Flat Section ; Measurement SW: DASY4, V4.7 Build 80; Postprocessing SW: SEMCAD, V1.8 Build 176

DASY4 Configuration:

- Probe: ET3DV6 - SN1631; ConvF(5.91, 5.91, 5.91); Calibrated: 2009-06-24
- Sensor-Surface: 4mm (Mechanical Surface Detection)
- Electronics: DAE3 Sn446; Calibrated: 2009-05-22
- Phantom: 835/900 Phantom ; Type: SAM

GSM Body 190/Area Scan (51x91x1): Measurement grid: dx=15mm, dy=15mm

[Info: Interpolated medium parameters used for SAR evaluation.](#)

Maximum value of SAR (interpolated) = 0.934 mW/g

GSM Body 190/Zoom Scan (5x5x7)/Cube 0: Measurement grid: dx=8mm, dy=8mm, dz=5mm

Reference Value = 18.3 V/m; Power Drift = -0.061 dB

Peak SAR (extrapolated) = 1.12 W/kg

SAR(1 g) = 0.889 mW/g; SAR(10 g) = 0.652 mW/g

[Info: Interpolated medium parameters used for SAR evaluation.](#)

Maximum value of SAR (measured) = 0.940 mW/g

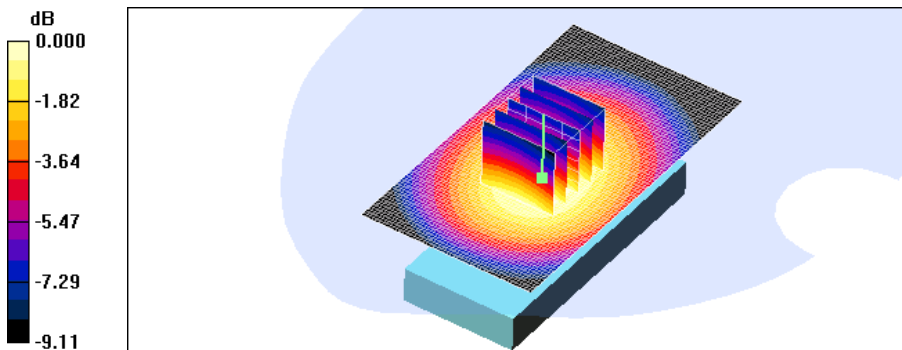

0 dB = 0.940mW/g

Test Laboratory: HCT CO., LTD
EUT Type: Cellular/PCS GSM Phone with Bluetooth
GPRS Class 10 and GPRS mode class B(GPRS and GSM, but not simultaneously)
Liquid Temperature: 21.3 °C
Ambient Temperature: 21.5 °C
Test Date: Dec.02, 2009

DUT: GX200; Type: Bar; Serial: #1

Communication System: GSM 850; Frequency: 848.8 MHz; Duty Cycle: 1:4.15
Medium parameters used (interpolated): $f = 848.8$ MHz; $\sigma = 0.953$ mho/m; $\epsilon_r = 54.9$; $\rho = 1000$ kg/m³
Phantom section: Flat Section ; Measurement SW: DASY4, V4.7 Build 80; Postprocessing SW: SEMCAD, V1.8 Build 176

DASY4 Configuration:

- Probe: ET3DV6 - SN1631; ConvF(5.91, 5.91, 5.91); Calibrated: 2009-06-24
- Sensor-Surface: 4mm (Mechanical Surface Detection)
- Electronics: DAE3 Sn446; Calibrated: 2009-05-22
- Phantom: 835/900 Phantom ; Type: SAM

GSM Body 251/Area Scan (51x91x1): Measurement grid: dx=15mm, dy=15mm

[Info: Interpolated medium parameters used for SAR evaluation.](#)

Maximum value of SAR (interpolated) = 0.863 mW/g

GSM Body 251/Zoom Scan (5x5x7)/Cube 0: Measurement grid: dx=8mm, dy=8mm, dz=5mm

Reference Value = 17.7 V/m; Power Drift = -0.044 dB

Peak SAR (extrapolated) = 1.03 W/kg

SAR(1 g) = 0.818 mW/g; SAR(10 g) = 0.592 mW/g

[Info: Interpolated medium parameters used for SAR evaluation.](#)

Maximum value of SAR (measured) = 0.863 mW/g

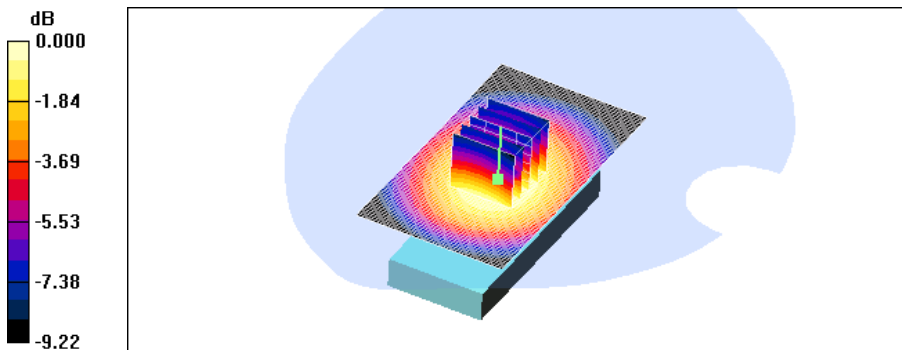

0 dB = 0.863mW/g

Test Laboratory: HCT CO., LTD
EUT Type: Cellular/PCS GSM Phone with Bluetooth
GPRS Class 10 and GPRS mode class B(GPRS and GSM, but not simultaneously)
Liquid Temperature: 21.3 °C
Ambient Temperature: 21.5 °C
Test Date: Dec.02, 2009

DUT: GX200; Type: Bar; Serial: #1

Communication System: GSM 850; Frequency: 824.2 MHz; Duty Cycle: 1:4.15
Medium parameters used: $f = 825$ MHz; $\sigma = 0.931$ mho/m; $\epsilon_r = 54.9$; $\rho = 1000$ kg/m³
Phantom section: Flat Section ; Measurement SW: DASY4, V4.7 Build 80; Postprocessing SW: SEMCAD, V1.8 Build 176

DASY4 Configuration:

- Probe: ET3DV6 - SN1631; ConvF(5.91, 5.91, 5.91); Calibrated: 2009-06-24
- Sensor-Surface: 4mm (Mechanical Surface Detection)
- Electronics: DAE3 Sn446; Calibrated: 2009-05-22
- Phantom: 835/900 Phantom ; Type: SAM

GSM Body 128/Area Scan (51x91x1): Measurement grid: dx=15mm, dy=15mm

Maximum value of SAR (interpolated) = 0.777 mW/g

GSM Body 128/Zoom Scan (5x5x7)/Cube 0: Measurement grid: dx=8mm, dy=8mm, dz=5mm

Reference Value = 17.3 V/m; Power Drift = -0.051 dB

Peak SAR (extrapolated) = 0.917 W/kg

SAR(1 g) = 0.733 mW/g; SAR(10 g) = 0.540 mW/g

Maximum value of SAR (measured) = 0.772 mW/g

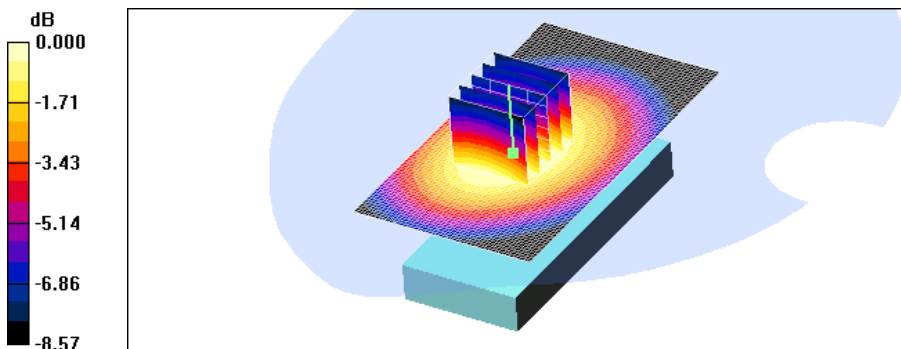

0 dB = 0.772mW/g

Test Laboratory: HCT CO., LTD
EUT Type: Cellular/PCS GSM Phone with Bluetooth
GPRS Class 10 and GPRS mode class B(GPRS and GSM, but not simultaneously)
Liquid Temperature: 21.3 °C
Ambient Temperature: 21.5 °C
Test Date: Dec.02, 2009

DUT: GX200; Type: Bar; Serial: #1

Communication System: GSM 850; Frequency: 824.2 MHz; Duty Cycle: 1:8.3
Medium parameters used: $f = 825$ MHz; $\sigma = 0.931$ mho/m; $\epsilon_r = 54.9$; $\rho = 1000$ kg/m³
Phantom section: Flat Section ; Measurement SW: DASY4, V4.7 Build 80; Postprocessing SW: SEMCAD, V1.8 Build 176

DASY4 Configuration:

- Probe: ET3DV6 - SN1631; ConvF(5.91, 5.91, 5.91); Calibrated: 2009-06-24
- Sensor-Surface: 4mm (Mechanical Surface Detection)
- Electronics: DAE3 Sn446; Calibrated: 2009-05-22
- Phantom: 835/900 Phantom ; Type: SAM

GSM Body 128/Area Scan (51x91x1): Measurement grid: dx=15mm, dy=15mm

Maximum value of SAR (interpolated) = 0.536 mW/g

GSM Body 128/Zoom Scan (5x5x7)/Cube 0: Measurement grid: dx=8mm, dy=8mm, dz=5mm

Reference Value = 13.6 V/m; Power Drift = -0.087 dB

Peak SAR (extrapolated) = 0.641 W/kg

SAR(1 g) = 0.510 mW/g; SAR(10 g) = 0.374 mW/g

Maximum value of SAR (measured) = 0.540 mW/g

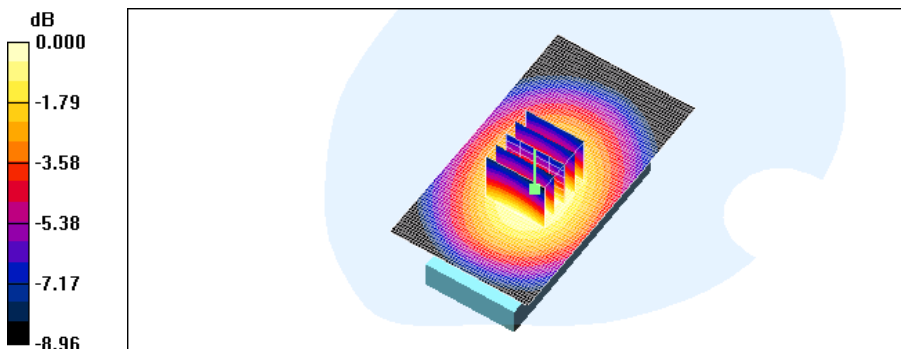

0 dB = 0.540mW/g

Test Laboratory: HCT CO., LTD
EUT Type: Cellular/PCS GSM Phone with Bluetooth
GPRS Class 10 and GPRS mode class B(GPRS and GSM, but not simultaneously)
Liquid Temperature: 21.2 °C
Ambient Temperature: 21.4 °C
Test Date: Dec.03, 2009

DUT: GX200; Type: Bar; Serial: #1

Communication System: GSM 1900; Frequency: 1880 MHz; Duty Cycle: 1:8.3
Medium parameters used: $f = 1880$ MHz; $\sigma = 1.47$ mho/m; $\epsilon_r = 53.6$; $\rho = 1000$ kg/m³
Phantom section: Flat Section ; Measurement SW: DASY4, V4.7 Build 80; Postprocessing SW: SEMCAD, V1.8 Build 176

DASY4 Configuration:

- Probe: ET3DV6 - SN1631; ConvF(4.48, 4.48, 4.48); Calibrated: 2009-06-24
- Sensor-Surface: 4mm (Mechanical Surface Detection)
- Electronics: DAE3 Sn446; Calibrated: 2009-05-22
- Phantom: 1800/1900 Phantom; Type: SAM

GSM Body 661/Area Scan (51x91x1): Measurement grid: dx=15mm, dy=15mm

Maximum value of SAR (interpolated) = 0.191 mW/g

GSM Body 661/Zoom Scan (5x5x7)/Cube 0: Measurement grid: dx=8mm, dy=8mm, dz=5mm

Reference Value = 8.24 V/m; Power Drift = 0.003 dB

Peak SAR (extrapolated) = 0.243 W/kg

SAR(1 g) = 0.177 mW/g; SAR(10 g) = 0.111 mW/g

Maximum value of SAR (measured) = 0.193 mW/g

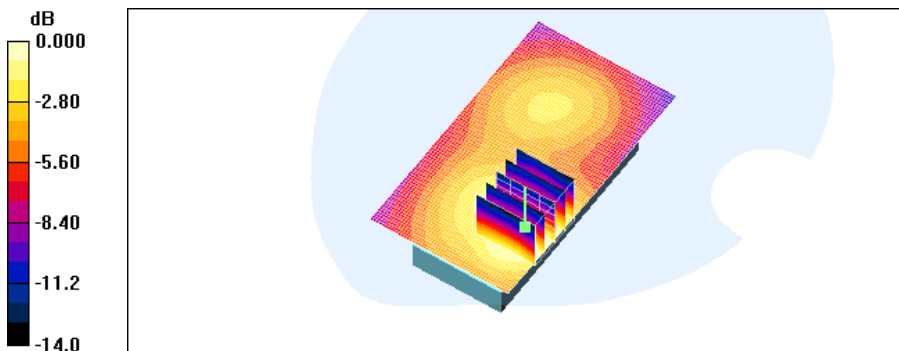

Test Laboratory: HCT CO., LTD
EUT Type: Cellular/PCS GSM Phone with Bluetooth
GPRS Class 10 and GPRS mode class B(GPRS and GSM, but not simultaneously)
Liquid Temperature: 21.2 °C
Ambient Temperature: 21.4 °C
Test Date: Dec.03, 2009

DUT: GX200; Type: Bar; Serial: #1

Communication System: GSM 1900; Frequency: 1880 MHz; Duty Cycle: 1:4.15
Medium parameters used: $f = 1880$ MHz; $\sigma = 1.47$ mho/m; $\epsilon_r = 53.6$; $\rho = 1000$ kg/m³
Phantom section: Flat Section ; Measurement SW: DASY4, V4.7 Build 80; Postprocessing SW: SEMCAD, V1.8 Build 176

DASY4 Configuration:

- Probe: ET3DV6 - SN1631; ConvF(4.48, 4.48, 4.48); Calibrated: 2009-06-24
- Sensor-Surface: 4mm (Mechanical Surface Detection)
- Electronics: DAE3 Sn446; Calibrated: 2009-05-22
- Phantom: 1800/1900 Phantom; Type: SAM

GSM Body 661/Area Scan (51x91x1): Measurement grid: dx=15mm, dy=15mm

Maximum value of SAR (interpolated) = 0.376 mW/g

GSM Body 661/Zoom Scan (5x5x7)/Cube 0: Measurement grid: dx=8mm, dy=8mm, dz=5mm

Reference Value = 11.6 V/m; Power Drift = -0.003 dB

Peak SAR (extrapolated) = 0.450 W/kg

SAR(1 g) = 0.343 mW/g; SAR(10 g) = 0.216 mW/g

Maximum value of SAR (measured) = 0.375 mW/g

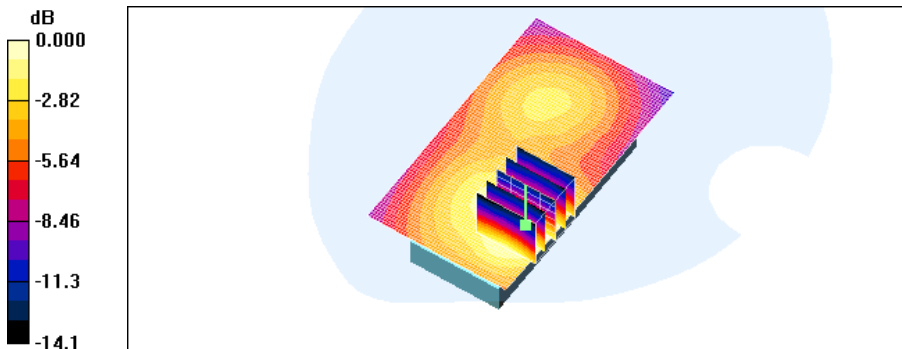

0 dB = 0.375mW/g

Test Laboratory: HCT CO., LTD
EUT Type: Cellular/PCS GSM Phone with Bluetooth
GPRS Class 10 and GPRS mode class B(GPRS and GSM, but not simultaneously)
Liquid Temperature: 21.2 °C
Ambient Temperature: 21.4 °C
Test Date: Dec.03, 2009

DUT: GX200; Type: Bar; Serial: #1

Communication System: GSM 1900; Frequency: 1880 MHz; Duty Cycle: 1:4.15
Medium parameters used: $f = 1880$ MHz; $\sigma = 1.47$ mho/m; $\epsilon_r = 53.6$; $\rho = 1000$ kg/m³
Phantom section: Flat Section ; Measurement SW: DASY4, V4.7 Build 80; Postprocessing SW: SEMCAD, V1.8 Build 176

DASY4 Configuration:

- Probe: ET3DV6 - SN1631; ConvF(4.48, 4.48, 4.48); Calibrated: 2009-06-24
- Sensor-Surface: 4mm (Mechanical Surface Detection)
- Electronics: DAE3 Sn446; Calibrated: 2009-05-22
- Phantom: 1800/1900 Phantom; Type: SAM

GSM Body 661/Area Scan (51x91x1): Measurement grid: dx=15mm, dy=15mm

Maximum value of SAR (interpolated) = 0.365 mW/g

GSM Body 661/Zoom Scan (5x5x7)/Cube 0: Measurement grid: dx=8mm, dy=8mm, dz=5mm

Reference Value = 12.4 V/m; Power Drift = -0.099 dB

Peak SAR (extrapolated) = 0.442 W/kg

SAR(1 g) = 0.318 mW/g; SAR(10 g) = 0.200 mW/g

Maximum value of SAR (measured) = 0.341 mW/g

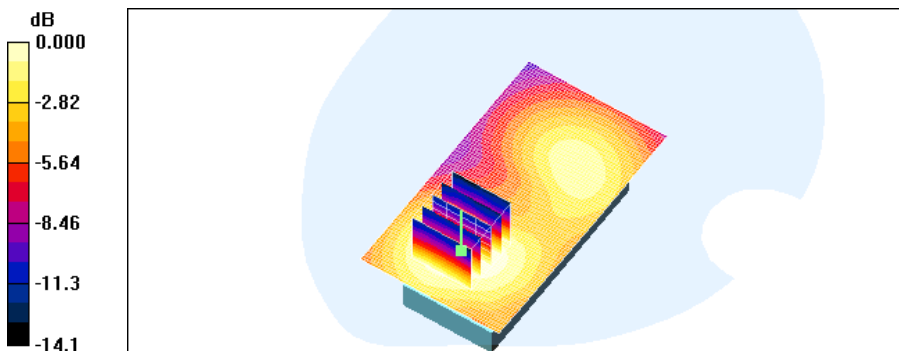

0 dB = 0.341mW/g

Test Laboratory: HCT CO., LTD
EUT Type: Cellular/PCS GSM Phone with Bluetooth
GPRS Class 10 and GPRS mode class B(GPRS and GSM, but not simultaneously)
Liquid Temperature: 21.2 °C
Ambient Temperature: 21.4 °C
Test Date: Dec.03, 2009

DUT: GX200; Type: Bar; Serial: #1

Communication System: GSM 1900; Frequency: 1880 MHz; Duty Cycle: 1:8.3
Medium parameters used: $f = 1880$ MHz; $\sigma = 1.47$ mho/m; $\epsilon_r = 53.6$; $\rho = 1000$ kg/m³
Phantom section: Flat Section ; Measurement SW: DASY4, V4.7 Build 80; Postprocessing SW: SEMCAD, V1.8 Build 176

DASY4 Configuration:

- Probe: ET3DV6 - SN1631; ConvF(4.48, 4.48, 4.48); Calibrated: 2009-06-24
- Sensor-Surface: 4mm (Mechanical Surface Detection)
- Electronics: DAE3 Sn446; Calibrated: 2009-05-22
- Phantom: 1800/1900 Phantom; Type: SAM

GSM Body 661/Area Scan (51x91x1): Measurement grid: dx=15mm, dy=15mm

Maximum value of SAR (interpolated) = 0.194 mW/g

GSM Body 661/Zoom Scan (5x5x7)/Cube 0: Measurement grid: dx=8mm, dy=8mm, dz=5mm

Reference Value = 8.28 V/m; Power Drift = 0.060 dB

Peak SAR (extrapolated) = 0.234 W/kg

SAR(1 g) = 0.177 mW/g; SAR(10 g) = 0.111 mW/g

Maximum value of SAR (measured) = 0.193 mW/g

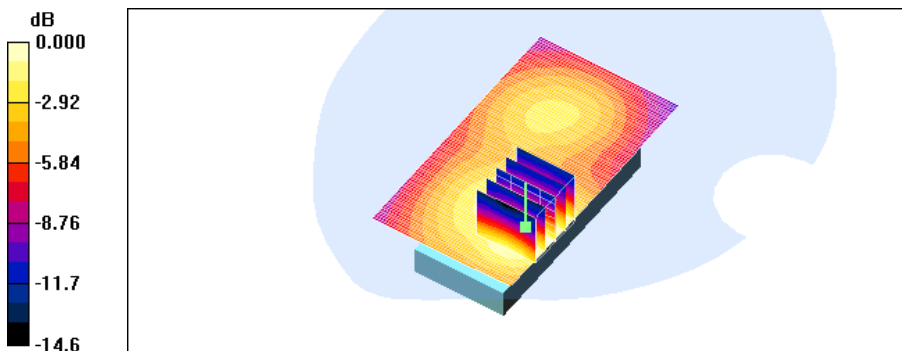

0 dB = 0.193mW/g

Test Laboratory: HCT CO., LTD
EUT Type: Cellular/PCS GSM Phone with Bluetooth
GPRS Class 10 and GPRS mode class B(GPRS and GSM, but not simultaneously)
Liquid Temperature: 21.2 °C
Ambient Temperature: 21.4 °C
Test Date: Dec.03, 2009

DUT: GX200; Type: Bar; Serial: #1

Communication System: GSM 1900; Frequency: 1880 MHz; Duty Cycle: 1:8.3
Medium parameters used: $f = 1880$ MHz; $\sigma = 1.47$ mho/m; $\epsilon_r = 53.6$; $\rho = 1000$ kg/m³
Phantom section: Flat Section ; Measurement SW: DASY4, V4.7 Build 80; Postprocessing SW: SEMCAD, V1.8 Build 176

DASY4 Configuration:

- Probe: ET3DV6 - SN1631; ConvF(4.48, 4.48, 4.48); Calibrated: 2009-06-24
- Sensor-Surface: 4mm (Mechanical Surface Detection)
- Electronics: DAE3 Sn446; Calibrated: 2009-05-22
- Phantom: 1800/1900 Phantom; Type: SAM

GSM Body 661/Area Scan (51x91x1): Measurement grid: dx=15mm, dy=15mm

Maximum value of SAR (interpolated) = 0.203 mW/g

GSM Body 661/Zoom Scan (5x5x7)/Cube 0: Measurement grid: dx=8mm, dy=8mm, dz=5mm

Reference Value = 8.36 V/m; Power Drift = -0.004 dB

Peak SAR (extrapolated) = 0.250 W/kg

SAR(1 g) = 0.191 mW/g; SAR(10 g) = 0.120 mW/g

Maximum value of SAR (measured) = 0.209 mW/g

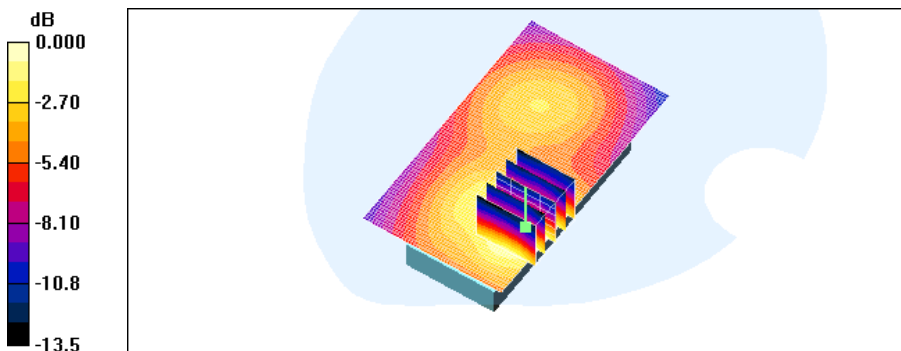

Test Laboratory: HCT CO., LTD
EUT Type: Cellular/PCS GSM Phone with Bluetooth
GPRS Class 10 and GPRS mode class B(GPRS and GSM, but not simultaneously)
Liquid Temperature: 21.2 °C
Ambient Temperature: 21.4 °C
Test Date: Dec.03, 2009

DUT: GX200; Type: Bar; Serial: #1

Communication System: GSM 1900; Frequency: 1880 MHz; Duty Cycle: 1:4.15
Medium parameters used: $f = 1880$ MHz; $\sigma = 1.47$ mho/m; $\epsilon_r = 53.6$; $\rho = 1000$ kg/m³
Phantom section: Flat Section ; Measurement SW: DASY4, V4.7 Build 80; Postprocessing SW: SEMCAD, V1.8 Build 176

DASY4 Configuration:

- Probe: ET3DV6 - SN1631; ConvF(4.48, 4.48, 4.48); Calibrated: 2009-06-24
- Sensor-Surface: 4mm (Mechanical Surface Detection)
- Electronics: DAE3 Sn446; Calibrated: 2009-05-22
- Phantom: 1800/1900 Phantom; Type: SAM

GSM Body 661/Area Scan (51x91x1): Measurement grid: dx=15mm, dy=15mm

Maximum value of SAR (interpolated) = 0.399 mW/g

GSM Body 661/Zoom Scan (5x5x7)/Cube 0: Measurement grid: dx=8mm, dy=8mm, dz=5mm

Reference Value = 11.6 V/m; Power Drift = 0.006 dB

Peak SAR (extrapolated) = 0.500 W/kg

SAR(1 g) = 0.376 mW/g; SAR(10 g) = 0.236 mW/g

Maximum value of SAR (measured) = 0.412 mW/g

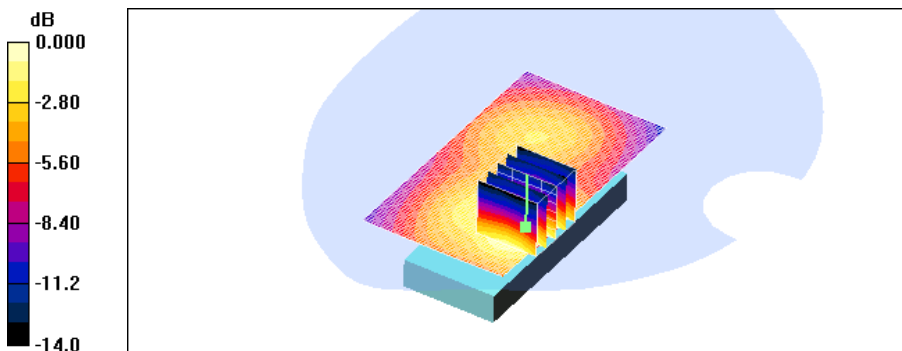

0 dB = 0.412mW/g

Test Laboratory: HCT CO., LTD
EUT Type: Cellular/PCS GSM Phone with Bluetooth
GPRS Class 10 and GPRS mode class B(GPRS and GSM, but not simultaneously)
Liquid Temperature: 21.2 °C
Ambient Temperature: 21.4 °C
Test Date: Dec.03, 2009

DUT: GX200; Type: Bar; Serial: #1

Communication System: GSM 1900; Frequency: 1880 MHz; Duty Cycle: 1:4.15
Medium parameters used: $f = 1880$ MHz; $\sigma = 1.47$ mho/m; $\epsilon_r = 53.6$; $\rho = 1000$ kg/m³
Phantom section: Flat Section ; Measurement SW: DASY4, V4.7 Build 80; Postprocessing SW: SEMCAD, V1.8 Build 176

DASY4 Configuration:

- Probe: ET3DV6 - SN1631; ConvF(4.48, 4.48, 4.48); Calibrated: 2009-06-24
- Sensor-Surface: 4mm (Mechanical Surface Detection)
- Electronics: DAE3 Sn446; Calibrated: 2009-05-22
- Phantom: 1800/1900 Phantom; Type: SAM

GSM Body 661/Area Scan (51x91x1): Measurement grid: dx=15mm, dy=15mm
Maximum value of SAR (interpolated) = 0.344 mW/g

GSM Body 661/Zoom Scan (5x5x7)/Cube 0: Measurement grid: dx=8mm, dy=8mm, dz=5mm
Reference Value = 12.6 V/m; Power Drift = 0.007 dB
Peak SAR (extrapolated) = 0.410 W/kg
SAR(1 g) = 0.298 mW/g; SAR(10 g) = 0.188 mW/g
Maximum value of SAR (measured) = 0.323 mW/g

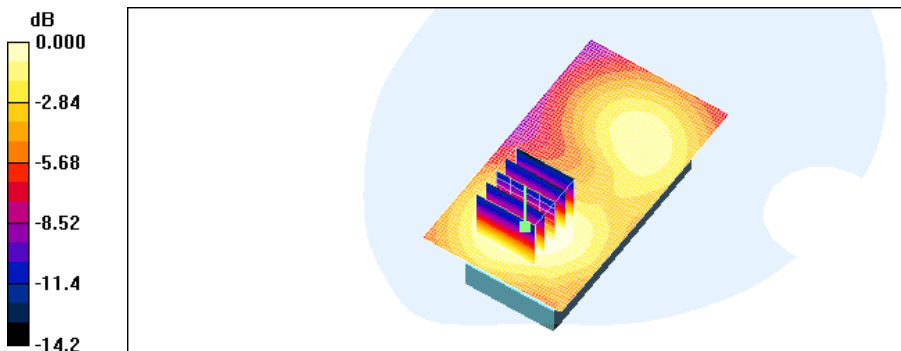

0 dB = 0.323mW/g

Test Laboratory: HCT CO., LTD
EUT Type: Cellular/PCS GSM Phone with Bluetooth
GPRS Class 10 and GPRS mode class B(GPRS and GSM, but not simultaneously)
Liquid Temperature: 21.2 °C
Ambient Temperature: 21.4 °C
Test Date: Dec.03, 2009

DUT: GX200; Type: Bar; Serial: #1

Communication System: GSM 1900; Frequency: 1880 MHz; Duty Cycle: 1:8.3
Medium parameters used: $f = 1880 \text{ MHz}$; $\sigma = 1.47 \text{ mho/m}$; $\epsilon_r = 53.6$; $\rho = 1000 \text{ kg/m}^3$
Phantom section: Flat Section ; Measurement SW: DASY4, V4.7 Build 80; Postprocessing SW: SEMCAD, V1.8 Build 176

DASY4 Configuration:

- Probe: ET3DV6 - SN1631; ConvF(4.48, 4.48, 4.48); Calibrated: 2009-06-24
- Sensor-Surface: 4mm (Mechanical Surface Detection)
- Electronics: DAE3 Sn446; Calibrated: 2009-05-22
- Phantom: 1800/1900 Phantom; Type: SAM

GSM Body 661/Area Scan (51x91x1): Measurement grid: $dx=15\text{mm}$, $dy=15\text{mm}$
Maximum value of SAR (interpolated) = 0.203 mW/g

GSM Body 661/Zoom Scan (5x5x7)/Cube 0: Measurement grid: $dx=8\text{mm}$, $dy=8\text{mm}$, $dz=5\text{mm}$
Reference Value = 8.38 V/m; Power Drift = 0.004 dB
Peak SAR (extrapolated) = 0.258 W/kg
SAR(1 g) = 0.192 mW/g; SAR(10 g) = 0.121 mW/g
Maximum value of SAR (measured) = 0.210 mW/g

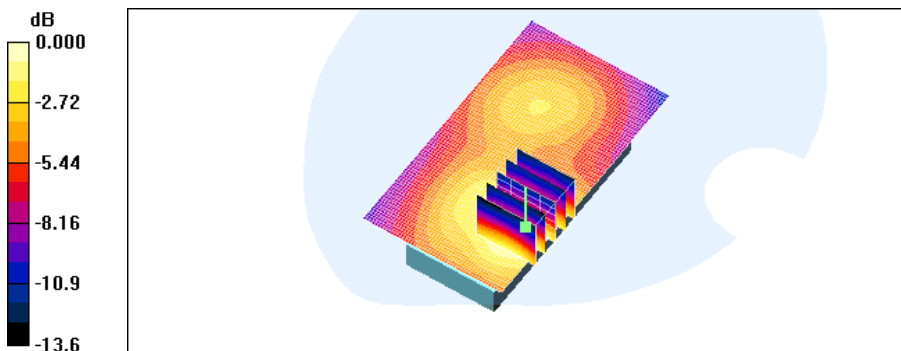

Attachment 2. – Dipole Validation Plots

■ Validation Data (835 MHz Head)

Test Laboratory: HCT CO., LTD
Input Power 100 mW (20 dBm)
Liquid Temp: 21.3 °C
Test Date: Dec. 2, 2009

DUT: Dipole 835 MHz; Type: D835V2; Serial: D835V2 – SN:441

Communication System: CW; Frequency: 835 MHz; Duty Cycle: 1:1
Medium parameters used: $f = 835$ MHz; $\sigma = 0.897$ mho/m; $\epsilon_r = 42.1$; $\rho = 1000$ kg/m³
Phantom section: Flat Section ; Measurement SW: DASY4, V4.7 Build 80; Postprocessing SW: SEMCAD, V1.8 Build 176

DASY4 Configuration:

- Probe: ET3DV6 – SN1631; ConvF(5.83, 5.83, 5.83); Calibrated: 2009-06-24
- Sensor-Surface: 4mm (Mechanical Surface Detection)
- Electronics: DAE3 Sn446; Calibrated: 2009-05-22
- Phantom: SAM 835/900 MHz; Type: SAM

Validation 835MHz/Area Scan (61x61x1): Measurement grid: dx=15mm, dy=15mm
Maximum value of SAR (interpolated) = 1.06 mW/g

Validation 835MHz/Zoom Scan (5x5x7)/Cube 0: Measurement grid: dx=8mm, dy=8mm, dz=5mm
Reference Value = 35.8 V/m; Power Drift = -0.091 dB
Peak SAR (extrapolated) = 1.41 W/kg
SAR(1 g) = 0.974 mW/g; SAR(10 g) = 0.641 mW/g
Maximum value of SAR (measured) = 1.05 mW/g

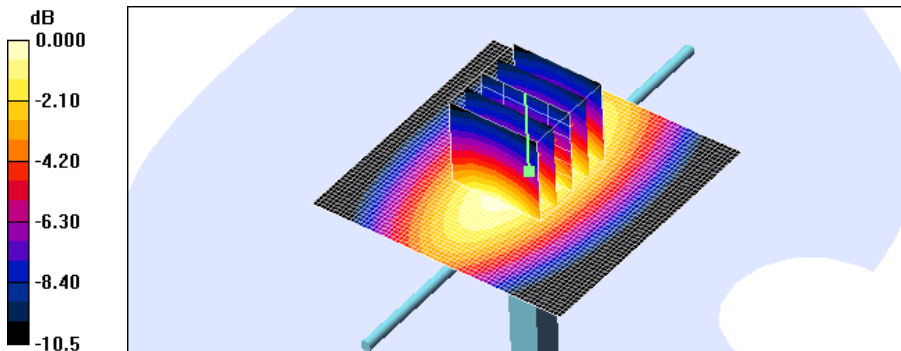

0 dB = 1.05mW/g

■ Validation Data (1900 MHz Head)

Test Laboratory: HCT CO., LTD
Input Power 100 mW (20 dBm)
Liquid Temp: 21.2 °C
Test Date: Dec. 3, 2009

DUT: Dipole 1900 MHz; Type: D1900V2; Serial: D1900V2 – SN:5d032

Communication System: CW; Frequency: 1900 MHz; Duty Cycle: 1:1
Medium parameters used: $f = 1900$ MHz; $\sigma = 1.42$ mho/m; $\epsilon_r = 39.4$; $\rho = 1000$ kg/m³
Phantom section: Flat Section ; Measurement SW: DASY4, V4.7 Build 80; Postprocessing SW: SEMCAD, V1.8 Build 176

DASY4 Configuration:

- Probe: ET3DV6 – SN1631; ConvF(5.07, 5.07, 5.07); Calibrated: 2009-06-24
- Sensor-Surface: 4mm (Mechanical Surface Detection)
- Electronics: DAE3 Sn446; Calibrated: 2009-05-22
- Phantom: SAM 1800/1900 MHz; Type: SAM

Dipole 1900MHz Validation/Area Scan (61x61x1): Measurement grid: dx=15mm, dy=15mm
Maximum value of SAR (interpolated) = 4.82 mW/g

Dipole 1900MHz Validation/Zoom Scan (5x5x7)/Cube 0: Measurement grid: dx=8mm, dy=8mm, dz=5mm
Reference Value = 59.8 V/m; Power Drift = -0.007 dB
Peak SAR (extrapolated) = 6.99 W/kg
SAR(1 g) = 4.06 mW/g; SAR(10 g) = 2.09 mW/g
Maximum value of SAR (measured) = 4.56 mW/g

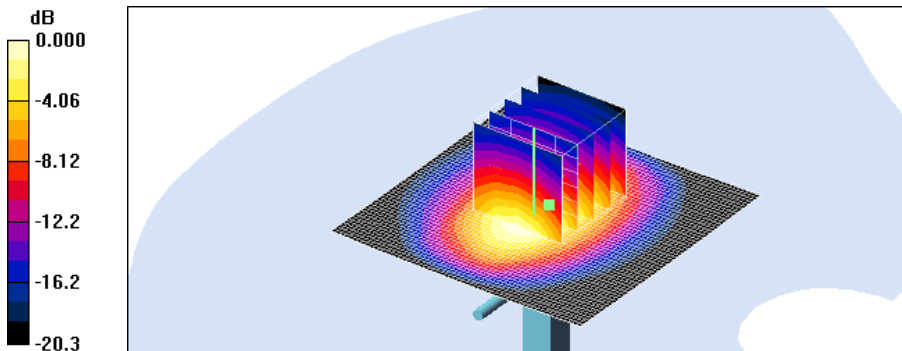

■ Dielectric Parameter (835 MHz Head)

Title GX200
SubTitle GSM850(Head)
Test Date Dec. 2, 2009

Frequency	e'	e''
800000000.0000	42.4939	19.4482
805000000.0000	42.4517	19.4447
810000000.0000	42.3821	19.4164
815000000.0000	42.3426	19.3964
820000000.0000	42.2472	19.4029
825000000.0000	42.2476	19.3668
830000000.0000	42.1826	19.3230
835000000.0000	42.1296	19.3184
840000000.0000	42.0686	19.2639
845000000.0000	42.0561	19.2849
850000000.0000	41.9693	19.2439
855000000.0000	41.9296	19.2726
860000000.0000	41.8953	19.2635
865000000.0000	41.8126	19.2790
870000000.0000	41.6927	19.2850
875000000.0000	41.6563	19.2416
880000000.0000	41.5661	19.2195
885000000.0000	41.5093	19.2384
890000000.0000	41.4397	19.2109
895000000.0000	41.3241	19.1927
900000000.0000	41.3218	19.1511

■ Dielectric Parameter (835 MHz Body)

Title GX200
SubTitle GSM850(Body)
Test Date Dec. 2, 2009

Frequency	e'	e''
800000000.0000	55.1862	20.2355
805000000.0000	55.1177	20.2382
810000000.0000	55.0467	20.2154
815000000.0000	54.9639	20.2444
820000000.0000	54.9501	20.2643
825000000.0000	54.8915	20.2898
830000000.0000	54.8646	20.2540
835000000.0000	54.8771	20.2151
840000000.0000	54.8443	20.2140
845000000.0000	54.8643	20.2019
850000000.0000	54.8584	20.1728
855000000.0000	54.8019	20.1540
860000000.0000	54.8104	20.1391
865000000.0000	54.7765	20.1564
870000000.0000	54.7534	20.0891
875000000.0000	54.6990	20.1269
880000000.0000	54.6820	20.0440
885000000.0000	54.5362	19.9916
890000000.0000	54.5043	19.9402
895000000.0000	54.4419	19.9239
900000000.0000	54.3711	19.9129

■ Dielectric Parameter (1900 MHz Head)

Title GX200
SubTitle GSM1900(Head)
Test Date Dec. 3, 2009

Frequency	e'	e''
1800000000.0000	39.9503	13.1310
1810000000.0000	39.9079	13.1280
1820000000.0000	39.8573	13.1394
1830000000.0000	39.7976	13.1294
1840000000.0000	39.7189	13.1498
1850000000.0000	39.6459	13.1580
1860000000.0000	39.5412	13.1566
1870000000.0000	39.4961	13.1812
1880000000.0000	39.4775	13.2696
1890000000.0000	39.4826	13.3130
1900000000.0000	39.4306	13.3954
1910000000.0000	39.4367	13.4317
1920000000.0000	39.4312	13.4664
1930000000.0000	39.3852	13.4916
1940000000.0000	39.3260	13.4901
1950000000.0000	39.2290	13.4697
1960000000.0000	39.2018	13.4512
1970000000.0000	39.1372	13.4635
1980000000.0000	39.0782	13.4871
1990000000.0000	39.0181	13.5117
2000000000.0000	39.0054	13.5923

■ Dielectric Parameter (1900 MHz Body)

Title GX200
SubTitle GSM1900(Body)
Test Date Dec. 3, 2009

Frequency	e'	e''
1850000000.0000	53.7061	13.9667
1855000000.0000	53.7107	13.9628
1860000000.0000	53.7106	13.9745
1865000000.0000	53.6850	13.9961
1870000000.0000	53.6925	14.0009
1875000000.0000	53.6376	14.0512
1880000000.0000	53.6087	14.0665
1885000000.0000	53.5727	14.0766
1890000000.0000	53.5397	14.0828
1895000000.0000	53.4871	14.1028
1900000000.0000	53.4725	14.1148
1905000000.0000	53.4572	14.1366
1910000000.0000	53.4246	14.1523
1915000000.0000	53.3494	14.1722
1920000000.0000	53.3523	14.2338
1925000000.0000	53.3389	14.2336
1930000000.0000	53.3075	14.2536
1935000000.0000	53.3255	14.2804
1940000000.0000	53.3313	14.2805
1945000000.0000	53.3215	14.3394
1950000000.0000	53.3413	14.3684

Attachment 3. – Probe Calibration Data

**Calibration Laboratory of
Schmid & Partner
Engineering AG**
Zeughausstrasse 43, 8004 Zurich, Switzerland



S Schweizerischer Kalibrierdienst
S Service suisse d'étalonnage
C Servizio svizzero di taratura
S Swiss Calibration Service

Accredited by the Swiss Accreditation Service (SAS)
The Swiss Accreditation Service is one of the signatories to the EA
Multilateral Agreement for the recognition of calibration certificates

Accreditation No.: **SCS 108**

Client **H-CT (Dymstec)**

Certificate No: **ET3-1631_Jun09**

CALIBRATION CERTIFICATE

Object **ET3DV6 - SN:1631**

Calibration procedure(s) **QA CAL-01.v6, QA CAL-12.v5 and QA CAL-23.v3
Calibration procedure for dosimetric E-field probes**

Calibration date: **June 24, 2009**

Condition of the calibrated item **In Tolerance**

This calibration certificate documents the traceability to national standards, which realize the physical units of measurements (SI).
The measurements and the uncertainties with confidence probability are given on the following pages and are part of the certificate.

All calibrations have been conducted in the closed laboratory facility: environment temperature (22 ± 3)°C and humidity < 70%.

Calibration Equipment used (M&TE critical for calibration)

Primary Standards	ID #	Cal Date (Certificate No.)	Scheduled Calibration
Power meter E4419B	GB41293874	1-Apr-09 (No. 217-01030)	Apr-10
Power sensor E4412A	MY41495277	1-Apr-09 (No. 217-01030)	Apr-10
Power sensor E4412A	MY41498087	1-Apr-09 (No. 217-01030)	Apr-10
Reference 3 dB Attenuator	SN: S5054 (3c)	31-Mar-09 (No. 217-01026)	Mar-10
Reference 20 dB Attenuator	SN: S5086 (20b)	31-Mar-09 (No. 217-01028)	Mar-10
Reference 30 dB Attenuator	SN: S5129 (30b)	31-Mar-09 (No. 217-01027)	Mar-10
Reference Probe ES3DV2	SN: 3013	2-Jan-09 (No. ES3-3013_Jan09)	Jan-10
DAE4	SN: 660	9-Sep-08 (No. DAE4-660_Sep08)	Sep-09
Secondary Standards	ID #	Check Date (in house)	Scheduled Check
RF generator HP 8648C	US3642U01700	4-Aug-99 (in house check Oct-07)	In house check: Oct-09
Network Analyzer HP 8753E	US37390585	18-Oct-01 (in house check Oct-08)	In house check: Oct-09

Calibrated by: **Jeton Kastrati** (Name) **Laboratory Technician** (Function) *[Signature]* (Signature)

Approved by: **Katja Pokovic** (Name) **Technical Manager** (Function) *[Signature]* (Signature)

Issued: June 24, 2009

This calibration certificate shall not be reproduced except in full without written approval of the laboratory.

Calibration Laboratory of
Schmid & Partner
Engineering AG
Zeughausstrasse 43, 8004 Zurich, Switzerland



S Schweizerischer Kalibrierdienst
S Service suisse d'étalonnage
C Servizio svizzero di taratura
S Swiss Calibration Service

Accredited by the Swiss Accreditation Service (SAS)
The Swiss Accreditation Service is one of the signatories to the EA
Multilateral Agreement for the recognition of calibration certificates

Accreditation No.: **SCS 108**

Glossary:

TSL tissue simulating liquid
 NORM_{x,y,z} sensitivity in free space
 ConvF sensitivity in TSL / NORM_{x,y,z}
 DCP diode compression point
 Polarization φ φ rotation around probe axis
 Polarization ϑ ϑ rotation around an axis that is in the plane normal to probe axis (at measurement center), i.e., $\vartheta = 0$ is normal to probe axis

Calibration is Performed According to the Following Standards:

- a) IEEE Std 1528-2003, "IEEE Recommended Practice for Determining the Peak Spatial-Averaged Specific Absorption Rate (SAR) in the Human Head from Wireless Communications Devices: Measurement Techniques", December 2003
- b) IEC 62209-1, "Procedure to measure the Specific Absorption Rate (SAR) for hand-held devices used in close proximity to the ear (frequency range of 300 MHz to 3 GHz)", February 2005

Methods Applied and Interpretation of Parameters:

- **NORM_{x,y,z}:** Assessed for E-field polarization $\vartheta = 0$ ($f \leq 900$ MHz in TEM-cell; $f > 1800$ MHz: R22 waveguide). NORM_{x,y,z} are only intermediate values, i.e., the uncertainties of NORM_{x,y,z} does not effect the E²-field uncertainty inside TSL (see below *ConvF*).
- **NORM(f)_{x,y,z} = NORM_{x,y,z} * frequency_response** (see Frequency Response Chart). This linearization is implemented in DASY4 software versions later than 4.2. The uncertainty of the frequency response is included in the stated uncertainty of *ConvF*.
- **DCP_{x,y,z}:** DCP are numerical linearization parameters assessed based on the data of power sweep (no uncertainty required). DCP does not depend on frequency nor media.
- **ConvF and Boundary Effect Parameters:** Assessed in flat phantom using E-field (or Temperature Transfer Standard for $f \leq 800$ MHz) and inside waveguide using analytical field distributions based on power measurements for $f > 800$ MHz. The same setups are used for assessment of the parameters applied for boundary compensation (alpha, depth) of which typical uncertainty values are given. These parameters are used in DASY4 software to improve probe accuracy close to the boundary. The sensitivity in TSL corresponds to NORM_{x,y,z} * *ConvF* whereby the uncertainty corresponds to that given for *ConvF*. A frequency dependent *ConvF* is used in DASY version 4.4 and higher which allows extending the validity from ± 50 MHz to ± 100 MHz.
- **Spherical isotropy (3D deviation from isotropy):** in a field of low gradients realized using a flat phantom exposed by a patch antenna.
- **Sensor Offset:** The sensor offset corresponds to the offset of virtual measurement center from the probe tip (on probe axis). No tolerance required.

ET3DV6 SN:1631

June 24, 2009

Probe ET3DV6

SN:1631

Manufactured:	October 12, 2001
Last calibrated:	October 29, 2001
Modified:	June 17, 2009
Recalibrated:	June 24, 2009

Calibrated for DASY Systems

(Note: non-compatible with DASY2 system!)

ET3DV6 SN:1631

June 24, 2009

DASY - Parameters of Probe: ET3DV6 SN:1631

Sensitivity in Free Space^A

Diode Compression^B

NormX	1.86 ± 10.1%	$\mu V/(V/m)^2$	DCP X	93 mV
NormY	1.83 ± 10.1%	$\mu V/(V/m)^2$	DCP Y	92 mV
NormZ	1.75 ± 10.1%	$\mu V/(V/m)^2$	DCP Z	92 mV

Sensitivity in Tissue Simulating Liquid (Conversion Factors)

Please see Page 8.

Boundary Effect

TSL 900 MHz Typical SAR gradient: 5 % per mm

Sensor Center to Phantom Surface Distance		3.7 mm	4.7 mm
SAR _{be} [%]	Without Correction Algorithm	11.8	7.6
SAR _{be} [%]	With Correction Algorithm	0.9	0.6

TSL 1750 MHz Typical SAR gradient: 10 % per mm

Sensor Center to Phantom Surface Distance		3.7 mm	4.7 mm
SAR _{be} [%]	Without Correction Algorithm	15.7	10.6
SAR _{be} [%]	With Correction Algorithm	0.8	0.7

Sensor Offset

Probe Tip to Sensor Center	2.7 mm
Optical Surface Detection	not supported

The reported uncertainty of measurement is stated as the standard uncertainty of measurement multiplied by the coverage factor k=2, which for a normal distribution corresponds to a coverage probability of approximately 95%.

^A The uncertainties of NormX,Y,Z do not affect the E²-field uncertainty inside TSL (see Page 8).

^B Numerical linearization parameter: uncertainty not required.

ET3DV6 SN:1631

June 24, 2009

Frequency Response of E-Field

(TEM-Cell:ifi110 EXX, Waveguide: R22)

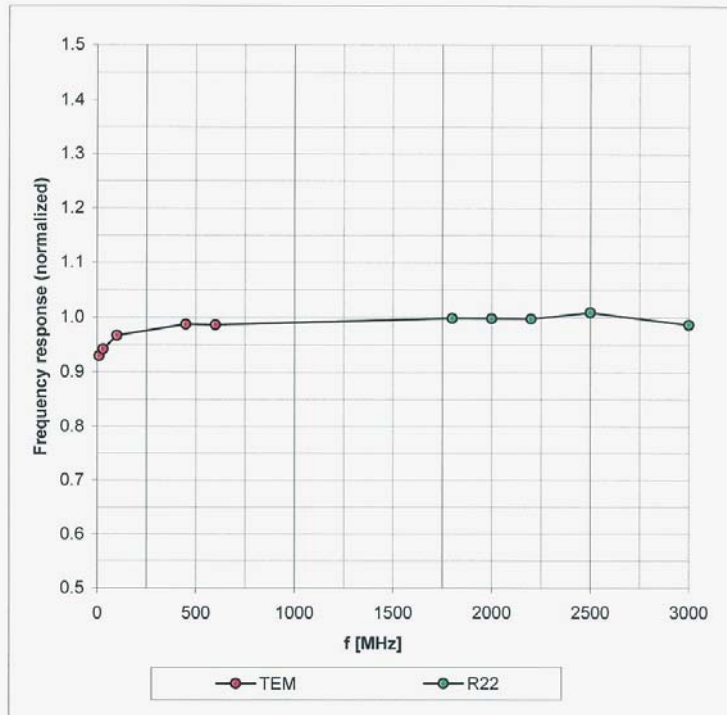

Uncertainty of Frequency Response of E-field: $\pm 6.3\%$ (k=2)

ET3DV6 SN:1631

June 24, 2009

Receiving Pattern (ϕ), $\vartheta = 0^\circ$

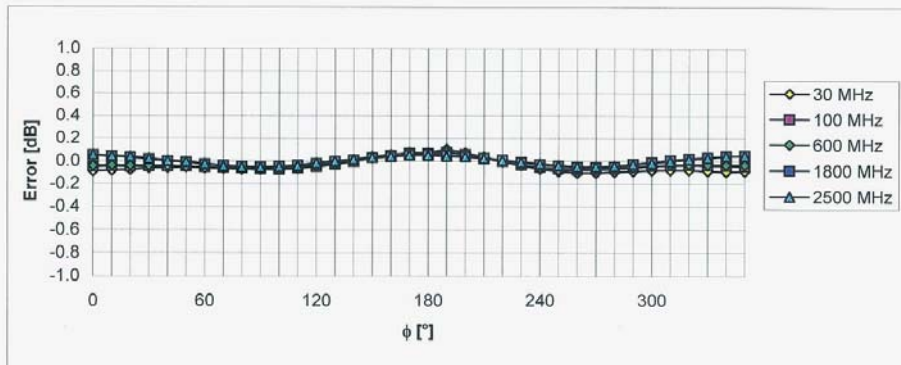
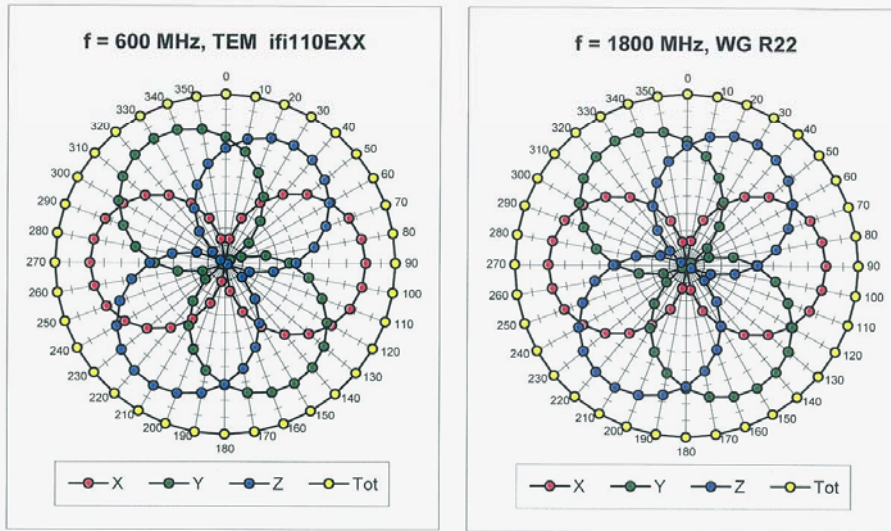

Uncertainty of Axial Isotropy Assessment: $\pm 0.5\%$ (k=2)

ET3DV6 SN:1631

June 24, 2009

Dynamic Range f(SAR_{head}) (Waveguide R22, f = 1800 MHz)

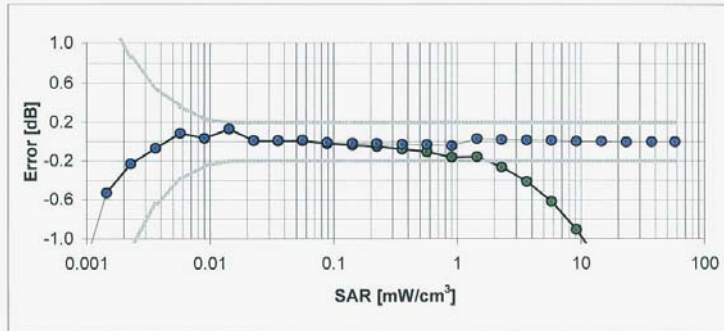
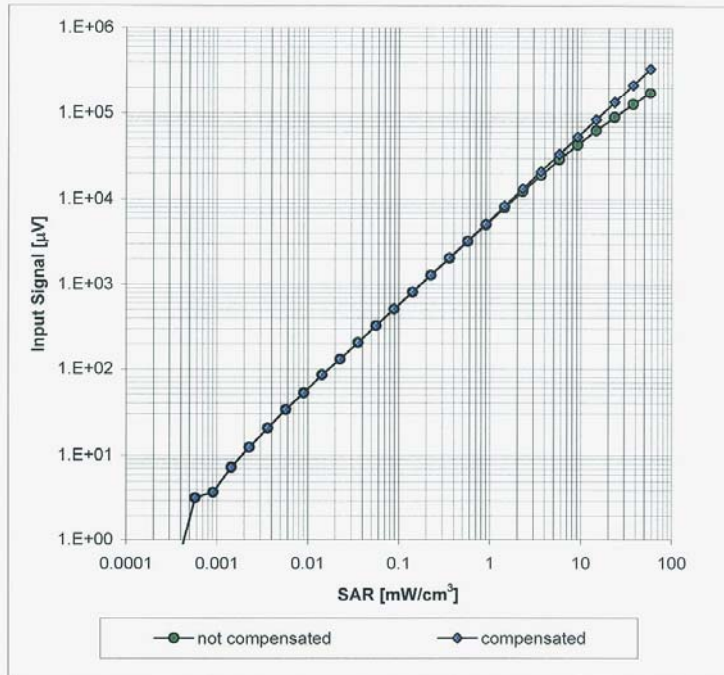

Uncertainty of Linearity Assessment: $\pm 0.6\%$ (k=2)

ET3DV6 SN:1631

June 24, 2009

Conversion Factor Assessment

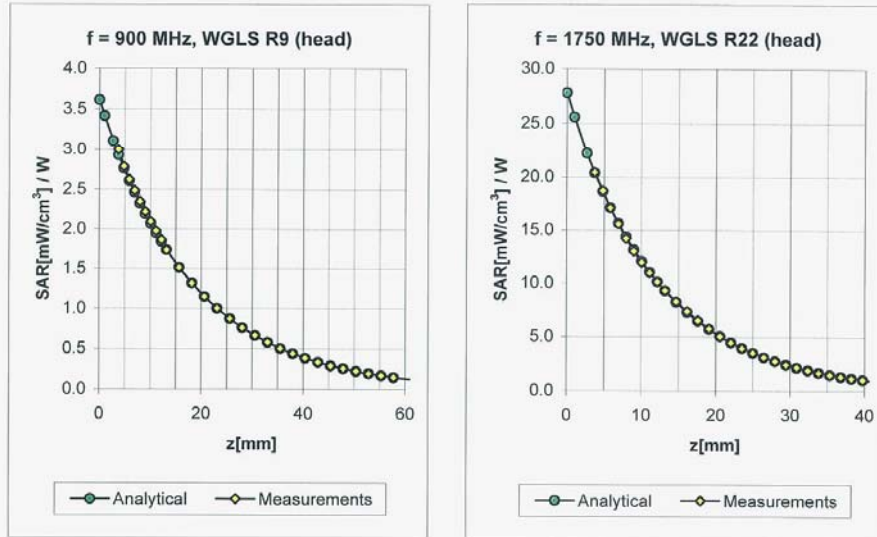

f [MHz]	Validity [MHz] ^c	TSL	Permittivity	Conductivity	Alpha	Depth	ConvF Uncertainty
450	± 50 / ± 100	Head	43.5 ± 5%	0.87 ± 5%	0.30	1.98	6.83 ± 13.3% (k=2)
835	± 50 / ± 100	Head	41.5 ± 5%	0.90 ± 5%	0.34	2.67	5.83 ± 11.0% (k=2)
900	± 50 / ± 100	Head	41.5 ± 5%	0.97 ± 5%	0.25	3.45	5.67 ± 11.0% (k=2)
1750	± 50 / ± 100	Head	40.1 ± 5%	1.37 ± 5%	0.67	2.50	5.30 ± 11.0% (k=2)
1900	± 50 / ± 100	Head	40.0 ± 5%	1.40 ± 5%	0.71	2.45	5.07 ± 11.0% (k=2)
1950	± 50 / ± 100	Head	40.0 ± 5%	1.40 ± 5%	0.69	2.46	4.90 ± 11.0% (k=2)
2450	± 50 / ± 100	Head	39.2 ± 5%	1.80 ± 5%	0.99	1.90	4.52 ± 11.0% (k=2)
450	± 50 / ± 100	Body	56.7 ± 5%	0.94 ± 5%	0.23	2.04	7.31 ± 13.3% (k=2)
835	± 50 / ± 100	Body	55.2 ± 5%	0.97 ± 5%	0.51	2.18	5.91 ± 11.0% (k=2)
1750	± 50 / ± 100	Body	53.4 ± 5%	1.49 ± 5%	0.63	3.28	4.67 ± 11.0% (k=2)
1900	± 50 / ± 100	Body	53.3 ± 5%	1.52 ± 5%	0.82	2.63	4.48 ± 11.0% (k=2)
1950	± 50 / ± 100	Body	53.3 ± 5%	1.52 ± 5%	0.92	2.40	4.60 ± 11.0% (k=2)
2450	± 50 / ± 100	Body	52.7 ± 5%	1.95 ± 5%	0.99	1.80	4.21 ± 11.0% (k=2)

^c The validity of ± 100 MHz only applies for DASY v4.4 and higher (see Page 2). The uncertainty is the RSS of the ConvF uncertainty at calibration frequency and the uncertainty for the indicated frequency band.

ET3DV6 SN:1631

June 24, 2009

Deviation from Isotropy in HSL

Error (ϕ , θ), $f = 900$ MHz

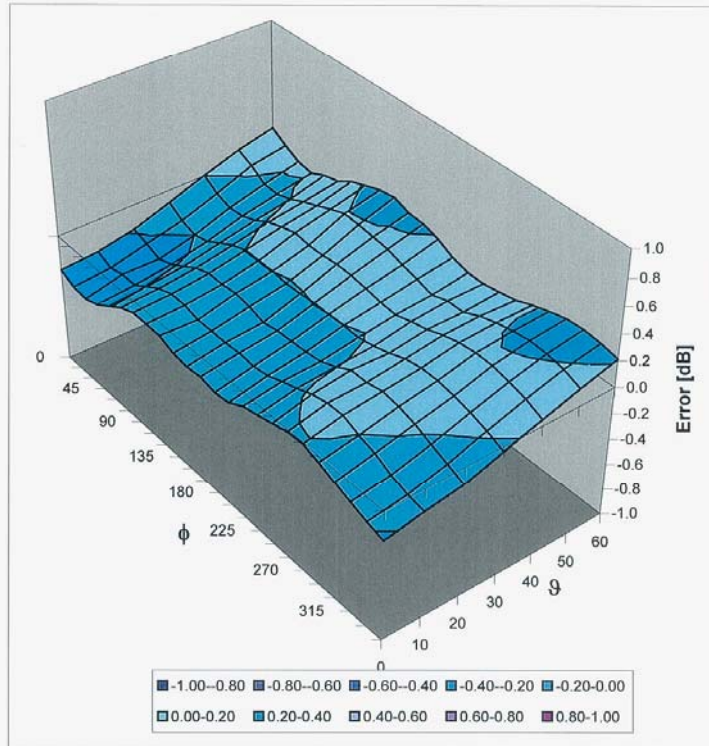

Uncertainty of Spherical Isotropy Assessment: $\pm 2.6\%$ ($k=2$)

Attachment 4. – Dipole Calibration Data

**Calibration Laboratory of
Schmid & Partner
Engineering AG**
Zeughausstrasse 43, 8004 Zurich, Switzerland



S Schweizerischer Kalibrierdienst
C Service suisse d'étalonnage
S Servizio svizzero di taratura
S Swiss Calibration Service

Accredited by the Swiss Accreditation Service (SAS)
The Swiss Accreditation Service is one of the signatories to the EA
Multilateral Agreement for the recognition of calibration certificates

Accreditation No.: **SCS 108**

Client **HTC (Dymstec)**

Certificate No: **D835V2-441_May09**

CALIBRATION CERTIFICATE

Object **D835V2 - SN: 441**

Calibration procedure(s) **QA CAL-05.v7
Calibration procedure for dipole validation kits**

Calibration date: **May 25, 2009**

Condition of the calibrated item **In Tolerance**

This calibration certificate documents the traceability to national standards, which realize the physical units of measurements (SI).
The measurements and the uncertainties with confidence probability are given on the following pages and are part of the certificate.

All calibrations have been conducted in the closed laboratory facility: environment temperature (22 ± 3)*C and humidity < 70%.

Calibration Equipment used (M&TE critical for calibration)

Primary Standards	ID #	Cal Date (Certificate No.)	Scheduled Calibration
Power meter EPM-442A	GB37480704	08-Oct-08 (No. 217-00898)	Oct-09
Power sensor HP 8481A	US37292783	08-Oct-08 (No. 217-00898)	Oct-09
Reference 20 dB Attenuator	SN: 5086 (20g)	31-Mar-09 (No. 217-01025)	Mar-10
Type-N mismatch combination	SN: 5047.2 / 06327	31-Mar-09 (No. 217-01029)	Mar-10
Reference Probe ES3DV2	SN: 3025	30-Apr-09 (No. ES3-3025_Apr09)	Apr-10
DAE4	SN: 801	07-Mar-09 (No. DAE4-801_Mar09)	Mar-10
Secondary Standards	ID #	Check Date (in house)	Scheduled Check
Power sensor HP 8481A	MY41092317	18-Oct-02 (in house check Oct-07)	In house check: Oct-09
RF generator R&S SMT-06	100005	4-Aug-99 (in house check Oct-07)	In house check: Oct-09
Network Analyzer HP 8753E	US37390585 S4206	18-Oct-01 (in house check Oct-08)	In house check: Oct-09

Calibrated by:	Name Jeton Kastrati	Function Laboratory Technician	Signature
Approved by:	Name Katja Pokovic	Function Technical Manager	Signature

Issued: May 25, 2009

This calibration certificate shall not be reproduced except in full without written approval of the laboratory.

Calibration Laboratory of
Schmid & Partner
Engineering AG
Zeughausstrasse 43, 8004 Zurich, Switzerland



S Schweizerischer Kalibrierdienst
C Service suisse d'étalonnage
S Servizio svizzero di taratura
S Swiss Calibration Service

Accredited by the Swiss Accreditation Service (SAS)
The Swiss Accreditation Service is one of the signatories to the EA
Multilateral Agreement for the recognition of calibration certificates

Accreditation No.: **SCS 108**

Glossary:

TSL	tissue simulating liquid
ConvF	sensitivity in TSL / NORM x,y,z
N/A	not applicable or not measured

Calibration is Performed According to the Following Standards:

- IEEE Std 1528-2003, "IEEE Recommended Practice for Determining the Peak Spatial-Averaged Specific Absorption Rate (SAR) in the Human Head from Wireless Communications Devices: Measurement Techniques", December 2003
- IEC 62209-1, "Procedure to measure the Specific Absorption Rate (SAR) for hand-held devices used in close proximity to the ear (frequency range of 300 MHz to 3 GHz)", February 2005
- Federal Communications Commission Office of Engineering & Technology (FCC OET), "Evaluating Compliance with FCC Guidelines for Human Exposure to Radiofrequency Electromagnetic Fields; Additional Information for Evaluating Compliance of Mobile and Portable Devices with FCC Limits for Human Exposure to Radiofrequency Emissions", Supplement C (Edition 01-01) to Bulletin 65

Additional Documentation:

- DASY4/5 System Handbook

Methods Applied and Interpretation of Parameters:

- Measurement Conditions:* Further details are available from the Validation Report at the end of the certificate. All figures stated in the certificate are valid at the frequency indicated.
- Antenna Parameters with TSL:* The dipole is mounted with the spacer to position its feed point exactly below the center marking of the flat phantom section, with the arms oriented parallel to the body axis.
- Feed Point Impedance and Return Loss:* These parameters are measured with the dipole positioned under the liquid filled phantom. The impedance stated is transformed from the measurement at the SMA connector to the feed point. The Return Loss ensures low reflected power. No uncertainty required.
- Electrical Delay:* One-way delay between the SMA connector and the antenna feed point. No uncertainty required.
- SAR measured:* SAR measured at the stated antenna input power.
- SAR normalized:* SAR as measured, normalized to an input power of 1 W at the antenna connector.
- SAR for nominal TSL parameters:* The measured TSL parameters are used to calculate the nominal SAR result.

Measurement Conditions

DASY system configuration, as far as not given on page 1.

DASY Version	DASY5	V5.0
Extrapolation	Advanced Extrapolation	
Phantom	Modular Flat Phantom V4.9	
Distance Dipole Center - TSL	15 mm	with Spacer
Zoom Scan Resolution	dx, dy, dz = 5 mm	
Frequency	835 MHz \pm 1 MHz	

Head TSL parameters

The following parameters and calculations were applied.

	Temperature	Permittivity	Conductivity
Nominal Head TSL parameters	22.0 °C	41.5	0.90 mho/m
Measured Head TSL parameters	(22.0 \pm 0.2) °C	40.8 \pm 6 %	0.89 mho/m \pm 6 %
Head TSL temperature during test	(21.6 \pm 0.2) °C	----	----

SAR result with Head TSL

SAR averaged over 1 cm ³ (1 g) of Head TSL	Condition	
SAR measured	250 mW input power	2.38 mW / g
SAR normalized	normalized to 1W	9.52 mW / g
SAR for nominal Head TSL parameters ¹	normalized to 1W	9.56 mW / g \pm 17.0 % (k=2)

SAR averaged over 10 cm ³ (10 g) of Head TSL	condition	
SAR measured	250 mW input power	1.56 mW / g
SAR normalized	normalized to 1W	6.24 mW / g
SAR for nominal Head TSL parameters ¹	normalized to 1W	6.26 mW / g \pm 16.5 % (k=2)

¹ Correction to nominal TSL parameters according to d), chapter "SAR Sensitivities"

Appendix**Antenna Parameters with Head TSL**

Impedance, transformed to feed point	50.3 Ω - 7.4 j Ω
Return Loss	- 22.7 dB

General Antenna Parameters and Design

Electrical Delay (one direction)	1.393 ns
----------------------------------	----------

After long term use with 100W radiated power, only a slight warming of the dipole near the feedpoint can be measured.

The dipole is made of standard semirigid coaxial cable. The center conductor of the feeding line is directly connected to the second arm of the dipole. The antenna is therefore short-circuited for DC-signals.

No excessive force must be applied to the dipole arms, because they might bend or the soldered connections near the feedpoint may be damaged.

Additional EUT Data

Manufactured by	SPEAG
Manufactured on	March 09, 2001

DASY5 Validation Report for Head TSL

Date/Time: 25.05.2009 09:55:22

Test Laboratory: SPEAG, Zurich, Switzerland

DUT: Dipole 835 MHz; Type: D835V2; Serial: D835V2 - SN:441

Communication System: CW-835; Frequency: 835 MHz; Duty Cycle: 1:1

Medium: HSL 900 MHz

Medium parameters used: $f = 835$ MHz; $\sigma = 0.89$ mho/m; $\epsilon_r = 40.7$; $\rho = 1000$ kg/m³

Phantom section: Flat Section

Measurement Standard: DASY5 (IEEE/IEC)

DASY5 Configuration:

- Probe: ES3DV2 - SN3025; ConvF(5.86, 5.86, 5.86); Calibrated: 30.04.2009
- Sensor-Surface: 3mm (Mechanical Surface Detection)
- Electronics: DAE4 Sn601; Calibrated: 07.03.2009
- Phantom: Flat Phantom 4.9L; Type: QD000P49AA; Serial: 1001
- Measurement SW: DASY5, V5.0 Build 120; SEMCAD X Version 13.4 Build 45

Pin=250mW; dip=15mm/Zoom Scan (7x7x7)/Cube 0; Measurement grid: dx=5mm, dy=5mm, dz=5mm

Reference Value = 57.1 V/m; Power Drift = 0.0073 dB

Peak SAR (extrapolated) = 3.53 W/kg

SAR(1 g) = 2.38 mW/g; SAR(10 g) = 1.56 mW/g

Maximum value of SAR (measured) = 2.77 mW/g

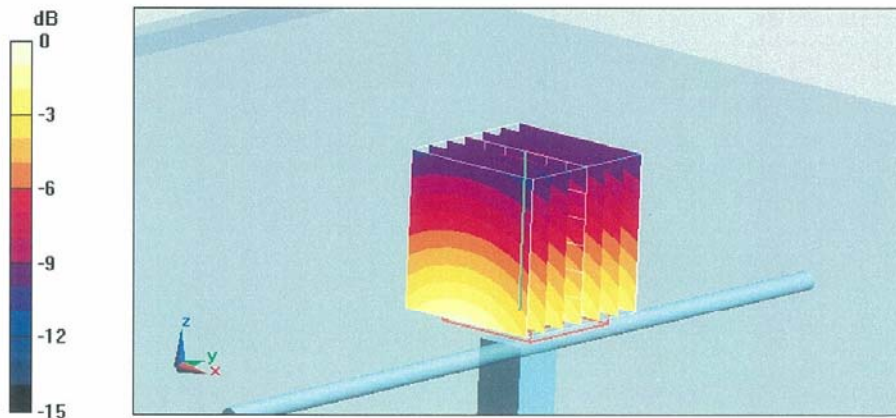

Impedance Measurement Plot for Head TSL

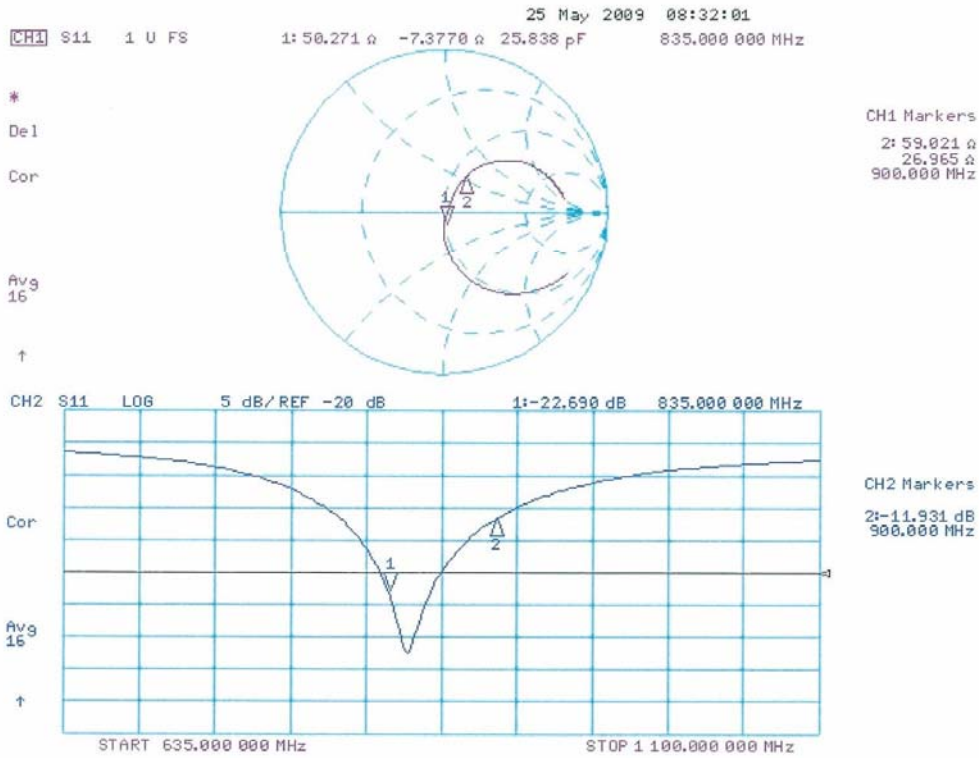

Calibration Laboratory of
Schmid & Partner
Engineering AG
Zeughausstrasse 43, 8004 Zurich, Switzerland



S Schweizerischer Kalibrierdienst
C Service suisse d'étalonnage
S Servizio svizzero di taratura
S Swiss Calibration Service

Accredited by the Swiss Accreditation Service (SAS)
The Swiss Accreditation Service is one of the signatories to the EA
Multilateral Agreement for the recognition of calibration certificates

Accreditation No.: **SCS 108**

Client **HCT (Dymstec)**

Certificate No: **D1900V2-5d032_Jul09**

CALIBRATION CERTIFICATE

Object: **D1900V2 - SN: 5d032**

Calibration procedure(s): **QA CAL-05.v7
Calibration procedure for dipole validation kits**

Calibration date: **July 20, 2009**

Condition of the calibrated item: **In Tolerance**

This calibration certificate documents the traceability to national standards, which realize the physical units of measurements (SI).
The measurements and the uncertainties with confidence probability are given on the following pages and are part of the certificate.

All calibrations have been conducted in the closed laboratory facility: environment temperature (22 ± 3)°C and humidity < 70%.

Calibration Equipment used (M&TE critical for calibration)

Primary Standards	ID #	Cal Date (Calibrated by, Certificate No.)	Scheduled Calibration
Power meter EPM-442A	GB37480704	08-Oct-08 (No. 217-00898)	Oct-09
Power sensor HP 8481A	US37292783	08-Oct-08 (No. 217-00898)	Oct-09
Reference 20 dB Attenuator	SN: 5086 (20g)	31-Mar-09 (No. 217-01025)	Mar-10
Type-N mismatch combination	SN: 5047.2 / 06327	31-Mar-09 (No. 217-01029)	Mar-10
Reference Probe ES3DV2	SN: 3025	30-Apr-09 (No. ES3-3025_Apr09)	Apr-10
DAE4	SN: 601	07-Mar-09 (No. DAE4-601_Mar09)	Mar-10
Secondary Standards	ID #	Check Date (in house)	Scheduled Check
Power sensor HP 8481A	MY41092317	18-Oct-02 (in house check Oct-07)	In house check: Oct-09
RF generator R&S SMT-06	100005	4-Aug-99 (in house check Oct-07)	In house check: Oct-09
Network Analyzer HP 8753E	US37390585 S4206	18-Oct-01 (in house check Oct-08)	In house check: Oct-09

Calibrated by: **Name** Claudio Leubler **Function** Laboratory Technician **Signature**

Approved by: **Name** Katja Pokovic **Function** Technical Manager **Signature**

Issued: July 22, 2009

This calibration certificate shall not be reproduced except in full without written approval of the laboratory.

Calibration Laboratory of
Schmid & Partner
Engineering AG
Zeughausstrasse 43, 8004 Zurich, Switzerland



S Schweizerischer Kalibrierdienst
S Service suisse d'étalonnage
C Servizio svizzero di taratura
S Swiss Calibration Service

Accredited by the Swiss Accreditation Service (SAS)

The Swiss Accreditation Service is one of the signatories to the EA
Multilateral Agreement for the recognition of calibration certificates

Accreditation No.: SCS 108

Glossary:

TSL	tissue simulating liquid
ConvF	sensitivity in TSL / NORM x,y,z
N/A	not applicable or not measured

Calibration is Performed According to the Following Standards:

- IEEE Std 1528-2003, "IEEE Recommended Practice for Determining the Peak Spatial-Averaged Specific Absorption Rate (SAR) in the Human Head from Wireless Communications Devices: Measurement Techniques", December 2003
- CENELEC EN 50361, "Basic standard for the measurement of Specific Absorption Rate related to human exposure to electromagnetic fields from mobile phones (300 MHz - 3 GHz), July 2001
- Federal Communications Commission Office of Engineering & Technology (FCC OET), "Evaluating Compliance with FCC Guidelines for Human Exposure to Radiofrequency Electromagnetic Fields; Additional Information for Evaluating Compliance of Mobile and Portable Devices with FCC Limits for Human Exposure to Radiofrequency Emissions", Supplement C (Edition 01-01) to Bulletin 65

Additional Documentation:

- DASY4/5 System Handbook

Methods Applied and Interpretation of Parameters:

- Measurement Conditions:** Further details are available from the Validation Report at the end of the certificate. All figures stated in the certificate are valid at the frequency indicated.
- Antenna Parameters with TSL:** The dipole is mounted with the spacer to position its feed point exactly below the center marking of the flat phantom section, with the arms oriented parallel to the body axis.
- Feed Point Impedance and Return Loss:** These parameters are measured with the dipole positioned under the liquid filled phantom. The impedance stated is transformed from the measurement at the SMA connector to the feed point. The Return Loss ensures low reflected power. No uncertainty required.
- Electrical Delay:** One-way delay between the SMA connector and the antenna feed point. No uncertainty required.
- SAR measured:** SAR measured at the stated antenna input power.
- SAR normalized:** SAR as measured, normalized to an input power of 1 W at the antenna connector.
- SAR for nominal TSL parameters:** The measured TSL parameters are used to calculate the nominal SAR result.

Measurement Conditions

DASY system configuration, as far as not given on page 1.

DASY Version	DASY5	V5.0
Extrapolation	Advanced Extrapolation	
Phantom	Modular Flat Phantom V5.0	
Distance Dipole Center - TSL	10 mm	with Spacer
Zoom Scan Resolution	dx, dy, dz = 5 mm	
Frequency	1900 MHz ± 1 MHz	

Head TSL parameters

The following parameters and calculations were applied.

	Temperature	Permittivity	Conductivity
Nominal Head TSL parameters	22.0 °C	40.0	1.40 mho/m
Measured Head TSL parameters	(22.0 ± 0.2) °C	40.9 ± 6 %	1.43 mho/m ± 6 %
Head TSL temperature during test	(22.0 ± 0.2) °C	----	----

SAR result with Head TSL

SAR averaged over 1 cm³ (1 g) of Head TSL	condition	
SAR measured	250 mW input power	10.2 mW / g
SAR normalized	normalized to 1W	40.8 mW / g
SAR for nominal Head TSL parameters ¹	normalized to 1W	40.5 mW / g ± 17.0 % (k=2)

SAR averaged over 10 cm³ (10 g) of Head TSL	Condition	
SAR measured	250 mW input power	5.36 mW / g
SAR normalized	normalized to 1W	21.4 mW / g
SAR for nominal Head TSL parameters ¹	normalized to 1W	21.4 mW / g ± 16.5 % (k=2)

¹ Correction to nominal TSL parameters according to d), chapter "SAR Sensitivities"

Appendix**Antenna Parameters with Head TSL**

Impedance, transformed to feed point	51.2 Ω + 4.4 j Ω
Return Loss	- 27.0 dB

General Antenna Parameters and Design

Electrical Delay (one direction)	1.197 ns
----------------------------------	----------

After long term use with 100W radiated power, only a slight warming of the dipole near the feedpoint can be measured.

The dipole is made of standard semirigid coaxial cable. The center conductor of the feeding line is directly connected to the second arm of the dipole. The antenna is therefore short-circuited for DC-signals.

No excessive force must be applied to the dipole arms, because they might bend or the soldered connections near the feedpoint may be damaged.

Additional EUT Data

Manufactured by	SPEAG
Manufactured on	March 17, 2003

DASY5 Validation Report for Head TSL

Date/Time: 20.07.2009 14:41:47

Test Laboratory: SPEAG, Zurich, Switzerland

DUT: Dipole 1900 MHz; Type: D1900V2; Serial: D1900V2 - SN:5d032

Communication System: CW; Frequency: 1900 MHz; Duty Cycle: 1:1

Medium: HSL U11 BB

Medium parameters used: $f = 1900$ MHz; $\sigma = 1.43$ mho/m; $\epsilon_r = 40.9$; $\rho = 1000$ kg/m³

Phantom section: Flat Section

Measurement Standard: DASY5 (IEEE/IEC)

DASY5 Configuration:

- Probe: ES3DV2 - SN3025; ConvF(4.88, 4.88, 4.88); Calibrated: 30.04.2009
- Sensor-Surface: 3mm (Mechanical Surface Detection)
- Electronics: DAE4 Sn601; Calibrated: 07.03.2009
- Phantom: Flat Phantom 5.0 (front); Type: QD000P50AA; Serial: 1001
- Measurement SW: DASY5, V5.0 Build 120; SEMCAD X Version 13.4 Build 45

Pin = 250 mW; dip = 10 mm, scan at 3.0 mm/Zoom Scan (dist=3.0 mm, probe 0deg)**(7x7x7)/Cube 0:** Measurement grid: dx=5mm, dy=5mm, dz=5mm

Reference Value = 94.5 V/m; Power Drift = 0.063 dB

Peak SAR (extrapolated) = 18.6 W/kg

SAR(1 g) = 10.2 mW/g; SAR(10 g) = 5.36 mW/g

Maximum value of SAR (measured) = 12.8 mW/g



Impedance Measurement Plot for Head TSL

