

FCC/IC TEST REPORT

Reference No. : G-45-2010-02216
 Applicant : LG Electronics Inc.
 Equipment Under Test (EUT) :

Product Name : Cellular/PCS GSM/EDGE & AWS WCDMA Phone
 with Bluetooth

Model Name : LG-GU297

Alt. Model Name : GU297, LG-GU297a, GU-297a

Applied Standards : FCC Part 15 : 2009, Subpart B, Class B

ANSI C63.4 : 2003

CISPR 22 : 2006



ICES-003 Issue 4 : 2004

Date of Receipt : August 02, 2010

Date of Test : August 11, 2010 ~ August 12, 2010

Date of Issue : September 14, 2010

Test Results : Complied

Tested by	:		 ----- Paul Kang
Reviewed by	:		 ----- Forest Lee

Note: Product name has been changed.

Remarks :

This report details the results of the testing carried out on one sample, the results contained in this test report do not relate to other samples of the same product. The manufacturer should ensure that all products in series production are in conformity with the product sample detailed in this report.

This report may only be reproduced and distributed in full. If the product in this report is used in any configuration other than that detailed in the report, the manufacturer must ensure the new system complies with all relevant standards. Any mention of SGS International Electrical Approvals or Testing done by SGS International Electrical Approvals in connection with distribution or use of the product described in this report must be approved by SGS International Electrical Approvals in writing.

Contents

1. General Information.....	3
1.1 Client Information.....	3
1.2 Test Laboratory.....	3
1.3 General Information of E.U.T.	3
1.4 Operating Modes and Conditions.....	3
1.5 Peripheral Equipments.....	3
1.6 Cable List.....	4
1.7 System Configurations.....	4
1.8 Test System Layout	4
1.9 Applicable Standards for Testing	5
1.10 Summary of Test Results.....	5
2. Emission Test.....	6
2.1 Test Results.....	6
2.2 Test Equipments	6
2.3 Test Site.....	6
2.4 Conducted Emission Test Data.....	6
2.5 Radiated Emission Test Data.....	7
2.6 Modifications	8
Appendix A : Conducted Emission	9

1. General Information

1.1 Client Information

Applicant : LG Electronics Inc.
 Address of Applicant : 60-39, Gasan-dong, Gumchon-gu, Seoul, 153-023, Korea
 Manufacturer : LG Electronics Inc.
 Address of Manufacturer : 60-39, Gasan-dong, Gumchon-gu, Seoul, 153-023, Korea

1.2 Test Laboratory

Name and Address : SGS Testing Korea Co., Ltd.
 18-34, Sanbon-dong, Gunpo, Gyeonggi-do, Korea
 435-041

1.3 General Information of E.U.T.

Product Name : Cellular/PCS GSM/EDGE & AWS WCDMA Phone with Bluetooth
 Model Name : LG-GU297
 Alt. Model Name : GU297, LG-GU297a, GU297a
 Model Difference : Only model name is different.
 FCC ID : BEJGU297
 IC Number : 2703C-GU297
 Serial No. : N/A
 Highest Internal Frequency : Max. 184 MHz
 Test Voltage : AC 120V, 60Hz(Notebook Computer)
 Battery DC 3.7V, 900 mAh Inside

1.4 Operating Modes and Conditions

Operating mode	Operating condition
USB Mode	USB Data Communication

Note: EUT was exercised through Software(Dell Program) during testing.

1.5 Peripheral Equipments

Description	Model	Serial No.	Manufacturer
Notebook Computer	PCG-3AHP	28272287 7000053	Sony Corporation
LCD Monitor	CR22KS	N843H1KP902165L	Samsung Electronics
USB Keyboard	KU-0459	7691402003981	Microsoft
USB MOUSE	M-BJ58	N/A	SUZHOU LOGITECH ELECTRONICS CO., LTD.
Micro SD Card	Mobile Ultra 2GB	N/A	SanDisk

Note: Peripherals are DoC.

1.6 Cable List

Start		END		Cable Spec.	
Name	I/O Port	Name	I/O Port	Length	Shield
Cellular/PCS GSM/EDGE & AWS WCDMA Phone with Bluetooth	USB	Notebook Computer	USB	1.2	Shielded
	-	Micro SD Card		-	-
Notebook Computer	DC IN	AC Adapter	DC OUT	1.8	Unshielded
	RGB	LCD Monitor	RGB	1.8	Shielded
	USB	USB Keyboard	-	2.0	Shielded
	USB	USB Mouse	-	1.8	Shielded
AC Adapter	AC IN	AC Source	-	1.0	Unshielded

1.7 System Configurations

Description	Model	Serial No.	Manufacturer
Battery	LGIP-430N	DC100529	LG
LCD Panel	N/A	S0610-A1	N/A
Main Board	GU295 MAIN 1.0	SPFY0209901(4)	N/A

1.8 Test System Layout

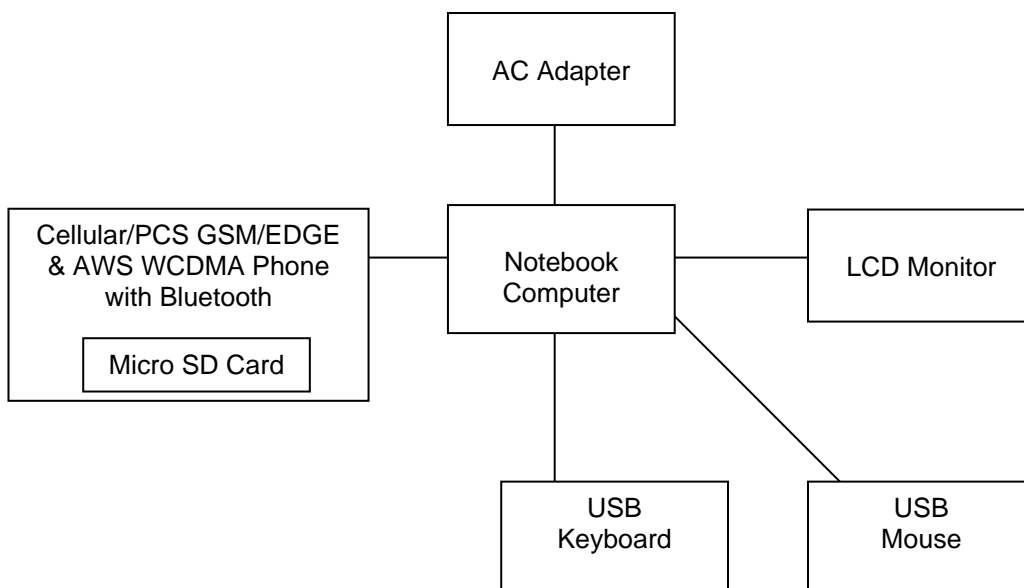

1.9 Applicable Standards for Testing

Standards	Status	Deviation
FCC Part 15 : 2009, Subpart B ANSI C63.4 : 2003 CISPR 22 : 2006 ICES-003 Issue 4 : 2004	Applicable	No Deviation

1.10 Summary of Test Results

Test Item	Standards	Results
Conducted Emission	FCC Part 15 : 2009, Subpart B ANSI C63.4 : 2003 CISPR 22 : 2006 ICES-003 Issue 4 : 2004	Complied
Radiated Emission	FCC Part 15 : 2009, Subpart B ANSI C63.4 : 2003 CISPR 22 : 2006 ICES-003 Issue 4 : 2004	Complied

EMISSION

2.1 Test Results

Test Items	Standards	Test Results
Conducted Emission	FCC Part 15 : 2009, Subpart B ANSI C63.4 : 2003 CISPR 22 : 2006 ICES-003 Issue 4 : 2004	Complied
Radiated Emission	FCC Part 15 : 2009, Subpart B ANSI C63.4 : 2003 CISPR 22 : 2006 ICES-003 Issue 4 : 2004	Complied

2.2 Test Equipments

Equipment	Model	Manufacturer	Last Cal. Date
Two-Line V-Network	ENV216	R&S	2010.01.06
Test Receiver	ESHS10	R&S	2010.07.12
LISN	L3-25	PMM	2010.07.09
Test Receiver	ESU26	R&S	2010.04.08
Amplifier	8447F	HP	2010.07.05
Bi-Log Antenna	VULB9163	SCHWARZBECK MESS- ELEKTRONIK	2009.07.22
Preamplifier	8449B	Agilent	2010.03.31
Horn Antenna	HF906	R&S	2009.10.08

Note : Only the calibration period of Antennas is 2 years but the period of every equipment is 1 year.

2.3 Test Site

Conducted Emission: Shield Room in Gunpo Laboratory

Radiated Emission: 3m Semi-Anechoic chamber in Gunpo Laboratory

2.4 Conducted Emission Test Data

The initial preliminary exploratory scans were performed using a max hold mode incorporating a Peak detector. The final test data was measured using a Quasi-Peak detector and Average detector.

Above 1GHz

Temperature : 23.7

Humidity : 51.0 % RH

Atmospheric Pressure : 100.1 kPa

FREQ. (MHz)	LEVEL (dB μ V)	POL (H/V)	A ($^{\circ}$)	H (m)	AF (dB)	CL (dB)	Amp (dB)	F/S (dB μ V/m)	LIMIT (dB μ V/m)	MARGIN (dB)
Average Detector										
1466.67	35.20	V	194	1.3	25.29	3.71	35.72	28.49	54.00	25.51
1787.29	34.90	V	326	1.1	26.74	4.11	34.74	31.01	54.00	22.99

Note: • AF = Antenna Factor • CL = Cable Loss • F/S = Field Strength
 • POL H = Horizontal • POL V = Vertical • Amp = Amplifier Gain
 • Margin = Limit – F/S • F/S = Level + AF + CL – Amp
 • A : Angle • H : Height

2.6 Modifications

There was no modified item during the test.

Appendix A : Conducted Emission

Neutral

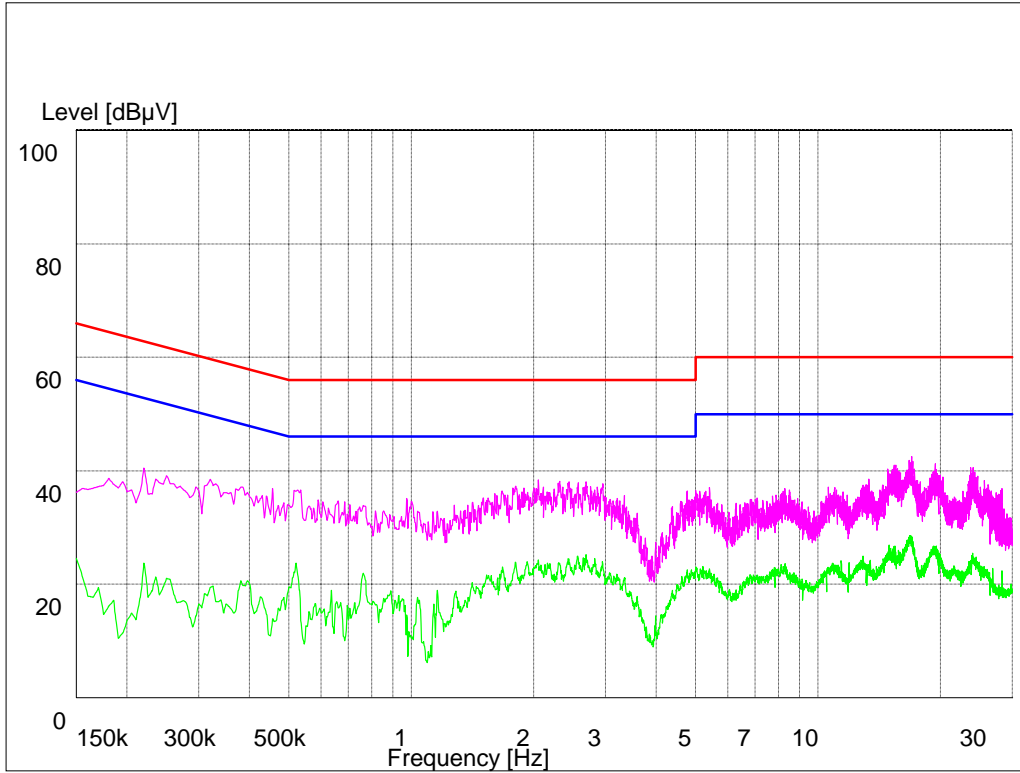

Hot

