



FCC TEST REPORT

According to

47 CFR, Part 2, Part 15 and CISPR PUB. 22

Applicant	: LG Electronics USA
Address	: 1000 Sylvan Avenue Englewood Cliffs New Jersey United States
Manufacturer	: LG Electronics Nanjing Display Co., Ltd.
Address	: No.346,Yaoxin Road Economic & Technical Development Zone Nanjing China
Equipment	: LCD Monitor
Model No.	: E2340TV
FCC ID	: BEJE2340TV
Trade Name	: LG

- The test result refers exclusively to the test presented test model / sample.
- Without written approval of **CerpPASS Technology Corp.** the test report shall not be reproduced except in full.
- The test report must not be used by the clients to claim product certification approval by **NVLAP** or any agency of the Government.



Table of Contents

1. Summary of Test Procedure and Test Result	5
2. Test Configuration of Equipment under Test.....	6
2.1. Feature of Equipment under Test	6
2.2. Test Manner.....	6
2.3. Description of Test System	7
2.4. Connection Diagram of Test System	7
2.5. General Information of Test	8
2.6. Measurement Uncertainty	8
3. Test of Conducted Emission	9
3.1. Test Limit	9
3.2. Test Procedures.....	9
3.3. Typical test Setup	10
3.4. Measurement equipment.....	10
3.5. Test Result and Data	11
4. Test of Radiated Emission.....	12
4.1. Test Limit	12
4.2. Test Procedures.....	13
4.3. Typical test Setup	13
4.4. Measurement equipment.....	14
4.5. Test Result and Data	15



Document history

Attachment No.	Date	Description
SEFD1002024	Feb 22, 2010	First issue



FCC TEST REPORT

According to

47 CFR, Part 2, Part 15 and CISPR PUB. 22

Applicant	: LG Electronics USA
Address	: 1000 Sylvan Avenue Englewood Cliffs New Jersey United States
Manufacturer	: LG Electronics Nanjing Display Co., Ltd.
Address	: No.346, Yaoxin Road Economic & Technical Development Zone Nanjing China
Equipment	: LCD Monitor
Model No.	: E2340TV
FCC ID	: BEJE2340TV
Trade Name	: LG

I **HEREBY** CERTIFY THAT :

The measurements shown in this test report were made in accordance with the procedures given in **ANSI C63.4 – 2003** and the energy emitted by this equipment was **passed CISPR PUB. 22 and FCC Part 15** in both radiated and conducted emission class B limits. Testing was carried out on Feb 10, 2010 at **CerpPASS Technology Corp.**

Documented By:

Approved By:

Sophie Li/ Administration

John Wang/ Technical director



1. Summary of Test Procedure and Test Result

Test Item	Normative References	Test Result
Conducted Emission	ANSI C63.4-2003 FCC Part 15 Subpart B	PASS
Radiated Emission	ANSI C63.4-2003 FCC Part 15 Subpart B	PASS



2. Test Configuration of Equipment under Test

2.1. Feature of Equipment under Test

LCD Monitor	Model No:	E2340TV
ADAPTER	Manufacturer:	LG
	Model No:	LCAP07F
	Input:	100-240V~ 50-60Hz 1.0A(1,0A) Max
	Output:	12V $\overline{\text{---}}$ 3.0A(3,0A)
DC Cable	Non-Shielded, 1.8m, with one ferrite core bonded	
VGA Cable	Shielded, 1.8m, with two ferrite cores bonded	
VGA Cable	Shielded, 1.8m	
DVI Cable	Shielded, 1.8m, with two ferrite cores bonded	
DVI Cable	Shielded, 1.8m	
Power Supply	Non-Shielded, 1.8m	
Note : The VGA Cable and DVI Cable are alternative on selling.		

2.2. Test Manner

Test Software	
a	During testing, the interface cables and equipment positions were varied according to ANSI C63.4.
b	The complete test system included the Printer, PC, USB Mouse, USB Keyboard and EUT for EMI test.
c	During the test, setup up the EUT and all system, turn on the power of all Equipments, run the EMC test software "H", set the contrast control to maximum, set the brightness control to maximum, use white letters on a black background to represent all colors, make the EUT at the test mode and it is normal operation, and then test.
The pre-test modes	
	Test Mode 1: Full system (VGA mode 1920*1080@60Hz)
	Test Mode 2: Full system (VGA mode 1280*800@75Hz)
	Test Mode 3: Full system (VGA mode 800*600@60Hz)
	Test Mode 4: Full system (DVI mode 1920*1080@60Hz)
	Test Mode 5: Full system (DVI mode 1280*800@75Hz)
	Test Mode 6: Full system (DVI mode 800*600@60Hz)
Select the worst case of the pre-test modes as the final test mode	
	Test Mode 1: Full system (VGA mode 1920*1080@60Hz)



2.3. Description of Test System

No	Device	Manufacturer	Model No.	Description
1	Printer	Epson	EX3	N/A
2	PC	Dell	DCTA	N/A
3	USB Mouse	DELL	G0K02XYK	N/A
4	USB Keyboard	DELL	SK-8115	N/A

2.4. Connection Diagram of Test System

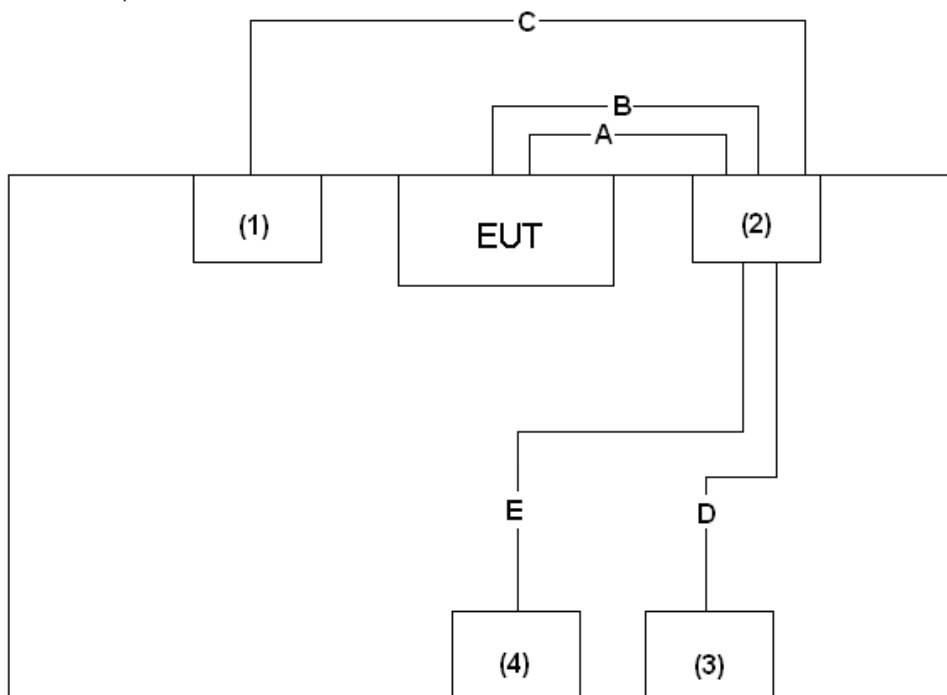

No	Cable	Quantity	Description
A	VGA Cable	1	Shielded, 1.8m
B	DVI Cable	1	Shielded, 1.8m
C	Parallel Cable	1	Shielded, 1.8m
D	USB Cable	1	Shielded, 1.5m
E	USB Cable	1	Shielded, 1.8m, with one ferrite core bonded

**2.5. General Information of Test**

Test Site :	Cerpass Technology Corp.
Performed Location :	No.66, Tangzhuang Road, Suzhou Industrial Park, Jiangsu, China
NVLAP LAB Code :	200814-0
FCC Registration Number :	916572
VCCI Registration Number :	T-343 for Telecommunication Test C-2919 for Conducted emission test R-2670 for Radiated emission test
Test in Compliance with :	ANSI C63.4-2003 FCC Part 15 Subpart B
Frequency Range Investigated :	Conducted: from 150kHz to 30 MHz Radiation: from 30 MHz to 1,000 MHz Radiation: from 1GHz to 18GHz
Test Distance :	The test distance of radiated emission below 1GHz from antenna to EUT is 3 M. The test distance of radiated emission above 1GHz from antenna to EUT is 3 M.

Laboratory accreditation

**2.6. Measurement Uncertainty**

Conducted Emission		
The measurement uncertainty is evaluated as ± 2.71 dB.		
Radiated Emission		
(30MHz -1000MHz)	Horizontal	The measurement uncertainty is evaluated as ± 3.89 dB.
	Vertical	The measurement uncertainty is evaluated as ± 3.59 dB.
(1G-18GHz)	Horizontal	The measurement uncertainty is evaluated as ± 2.31 dB.
	Vertical	The measurement uncertainty is evaluated as ± 2.15 dB.



3. Test of Conducted Emission

3.1. Test Limit

Conducted Emissions were measured from 150 kHz to 30 MHz with a bandwidth of 9 KHz on the 120 VAC power and return leads of the EUT according to the methods defined in ANSI C63.4-2003 Section 3.1. The EUT was placed on a nonmetallic stand in a shielded room 0.8 meters above the ground plane as shown in section 2.2. The interface cables and equipment positioning were varied within limits of reasonable applications to determine the position produced maximum conducted emissions.

Frequency (MHz)	Quasi Peak (dB μ V)	Average (dB μ V)
0.15 – 0.5	66-56*	56-46*
0.5 – 5.0	56	46
5.0 – 30.0	60	50

3.2. Test Procedures

- a. The EUT was placed 0.4 meter from the conducting wall of the shielding room was kept at least 80 centimeters from any other grounded conducting surface.
- b. Connect EUT to the power mains through a line impedance stabilization network (LISN).
- c. All the support units are connecting to the other LISN.
- d. The LISN provides 50 ohm coupling impedance for the measuring instrument.
- e. The FCC states that a 50 ohm, 50 micro-Henry LISN should be used.
- f. Both sides of AC line were checked for maximum conducted interference.
- g. The frequency range from 150 kHz to 30 MHz was searched.
- h. Set the test-receiver system to Peak Detect Function and Specified Bandwidth with Maximum Hold Mode.

3.3. Typical test Setup

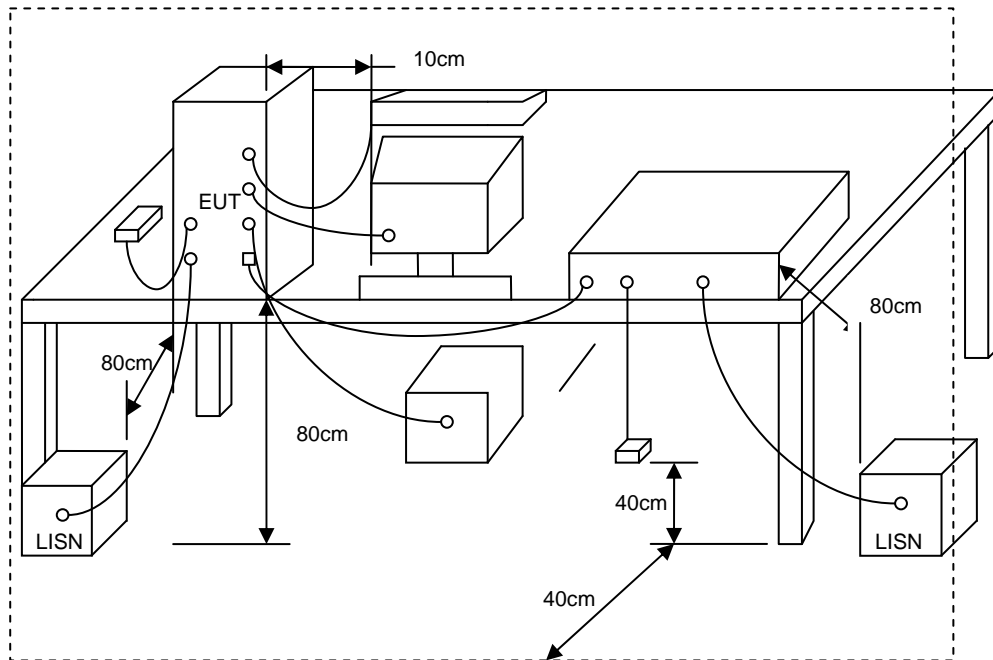

3.4. Measurement equipment

Instrument	Manufacturer	Model No.	Serial No.	Calibration Date
EMC Emission Tester	EMCPARTNER	Harmonics-1000	159	2009.09.08
Test Receiver	R&S	ESCI	100565	2010.01.15
AMN	R&S	ESH2-Z5	100182	2009.06.23
Two-Line V-Network	R&S	ENV216	100325	2009.06.23
ISN	FCC	FCC-TLISN-T2-02	20379	2009.06.23
ISN	FCC	FCC-TLISN-T4-02	20380	2009.06.23
ISN	FCC	FCC-TLISN-T8-02	20381	2009.06.23
Attenuator	R&S	ESH3-Z2	100529	2010.01.11
Temperature/ Humidity Meter	Zhicheng	ZC1-11	CEP-TH-004	2009.10.19



3.5. Test Result and Data

Test Mode :	Mode 1: Full system (VGA mode 1920*1080@60Hz)		
AC Power :	AC 120V/60Hz	Phase :	L&N
EUT :	LCD Monitor	Model No.:	E2340TV
Temperature :	20°C	Humidity :	43%
Pressur(mbar) :	1002	Date :	2010/02/05

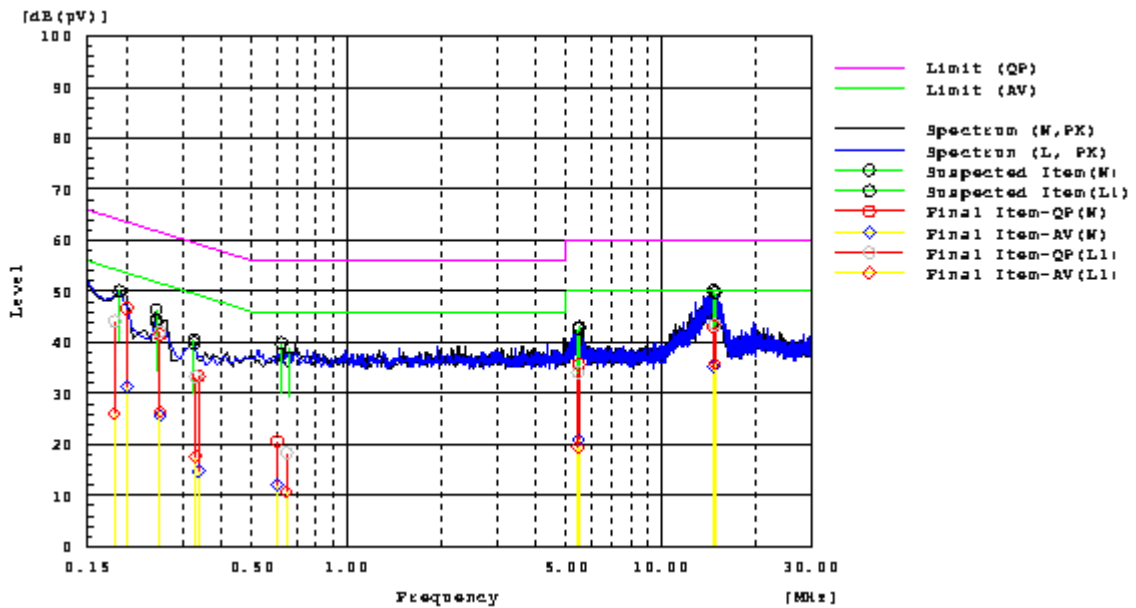

Frequency MHz	Line Phase	Reading dB(uV) QP	Reading dB(uV) AV	Factor dB	Level dB(uV) QP	Level dB(uV) AV	Limit dB(uV) QP	Limit dB(uV) AV	Margin dB QP	Margin dB AV	Pass/Fail
0.18308	L1	24.7	6.6	19.5	44.2	26.1	64.3	54.3	20.1	28.2	Pass
5.4297	L1	14.3	-0.4	19.8	34.1	19.4	60.0	50.0	25.9	30.6	Pass
14.8118	L1	23.3	15.6	20.2	43.5	35.8	60.0	50.0	16.5	14.2	Pass
0.25408	L1	22.5	7.0	19.5	42.0	26.5	61.6	51.6	19.6	25.1	Pass
0.64431	L1	-1.2	-8.8	19.6	18.4	10.8	56.0	46.0	37.6	35.2	Pass
0.33032	L1	13.7	-1.9	19.6	33.3	17.7	59.4	49.4	26.1	31.7	Pass
0.19986	N	26.9	11.6	19.8	46.7	31.4	63.6	53.6	16.9	22.2	Pass
0.25457	N	21.8	5.8	19.8	41.6	25.6	61.6	51.6	20.0	26.0	Pass
5.4741	N	15.9	1.1	19.8	35.7	20.9	60.0	50.0	24.3	29.1	Pass
14.681	N	22.8	15.0	20.3	43.1	35.3	60.0	50.0	16.9	14.7	Pass
0.60086	N	1.1	-7.5	19.6	20.7	12.1	56.0	46.0	35.3	33.9	Pass
0.3375	N	13.7	-4.9	19.7	33.4	14.8	59.3	49.3	25.9	34.5	Pass

Note: Measurement Level = Reading Level + Correct Factor

Test engineer: *Chat Ges*



4. Test of Radiated Emission

4.1. Test Limit

Radiated emissions from 30 MHz to 1,000 MHz were measured with a bandwidth of 120 kHz according to the methods defines in ANSI C63.4-2003. The EUT was placed on a nonmetallic stand in the open-field site, 0.8 meter above the ground plane, as shown in section 3.2. The interface cables and equipment positions were varied within limits of reasonable applications to determine the positions producing maximum radiated emissions.

For unintentional device, according to § 15.109(a), except for Class A digital devices, the field strength of radiated emissions from unintentional radiators at a distance of 3 meters shall not exceed the following values:

Frequency (MHz)	Distance (m)	Level (dBuV/m)	Level (dBuV/m)
30 - 88	3	40(QP)	N/A
88 - 216	3	43(QP)	N/A
216-960	3	46(QP)	N/A
960-1000	3	54(QP)	N/A
1000-18000	3	74(PK)	54(AV)

For unintentional device, according to CISPR PUB.22, for Class B digital devices, the general requirement of field strength of radiated emissions from intentional radiators at a distance of 10 meters shall not exceed the below table.

Frequency (MHz)	Distance Meters	Radiated (dB μ V/ M)
30-230	10	30
230-1000	10	37



4.2. Test Procedures

- a. The EUT was placed on a Rota table top 0.8 meter above ground.
- b. The EUT and its simulators are placed on the ground. The turn table can rotate 360 degrees to determine the position of the maximum emission level. The EUT was positioned such that the distance from antenna to the EUT was 3 meters or 1 meter.
- c. The antenna can move up and down between 1 meter and 4 meters to find out the maximum emission level.
- d. Both horizontal and vertical polarization of the antenna are set on measurement. In order to find the maximum emission, all of the interface cables must be manipulated on radiated measurement.
- e. Radiated emissions were investigated over the frequency range from 30MHz to 1GHz using a receiver bandwidth of 120KHz and the frequency range from 1GHz to 18GHz using a receiver bandwidth of 1MHz.

4.3. Typical test Setup

Below 1GHz Test Setup

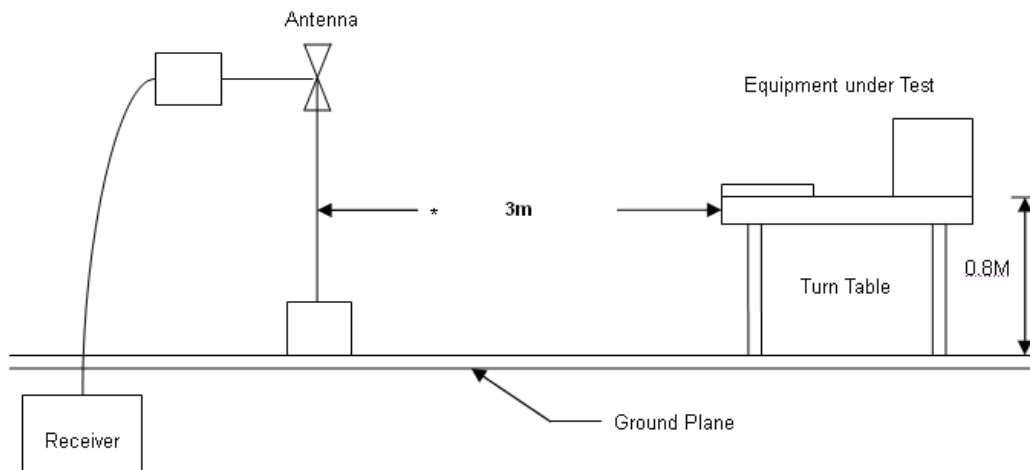



Above 1GHz Test Setup

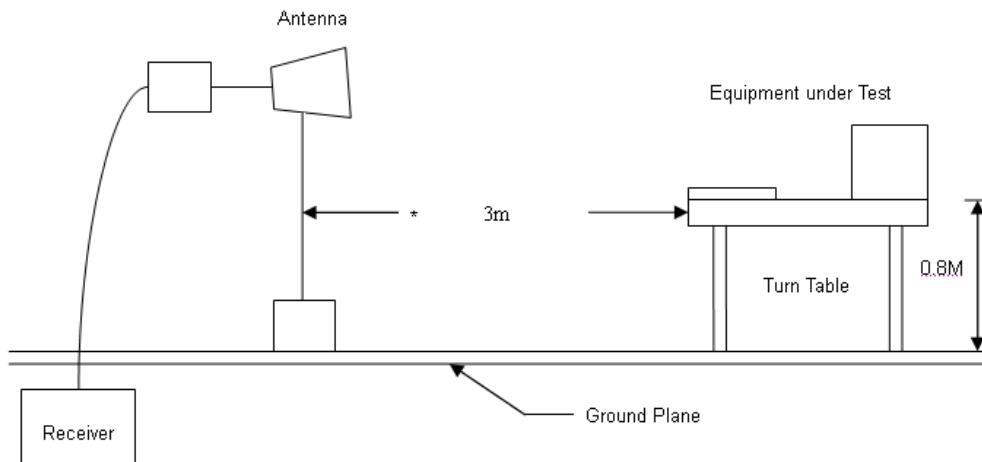

4.4. Measurement equipment

Instrument	Model No.	Manufacturer	Serial No.	Calibration Date
EMI Test Receiver	R&S	ESCI	100564	2009.06.23
H64 Amplifier	HP	8447F	3113A05582	2009.12.01
Preamplifier	Agilent	8449B	ED-HE-EMI-077	2009.02.18
Ultra Broadband Antenna	R&S	HL562	100362	2009.11.25
Broad-Band Horn Antenna	Schwarzbeck	BBHA9120D	9120D-619	2009.11.10
Spectrum Analyzer	R&S	FSP40	100324	2009.11.02
Temperature/ Humidity Meter	Zhicheng	ZC1-11	CEP-TH-001	2009.10.19



4.5. Test Result and Data

Under 1G

Engineer : Fred	
Site : EMC Lab AC 102	Time : 2010/02/05 - 15:03
Limit : FCC_CLASS_B_03M_QP	Margin : 6
EUT : LCD Monitor	Probe : HL562(30-1000MHz) - HORIZONTAL
Power : AC 120V/60Hz	Note : Mode 1: Full system (VGA mode 1920*1080@60Hz)

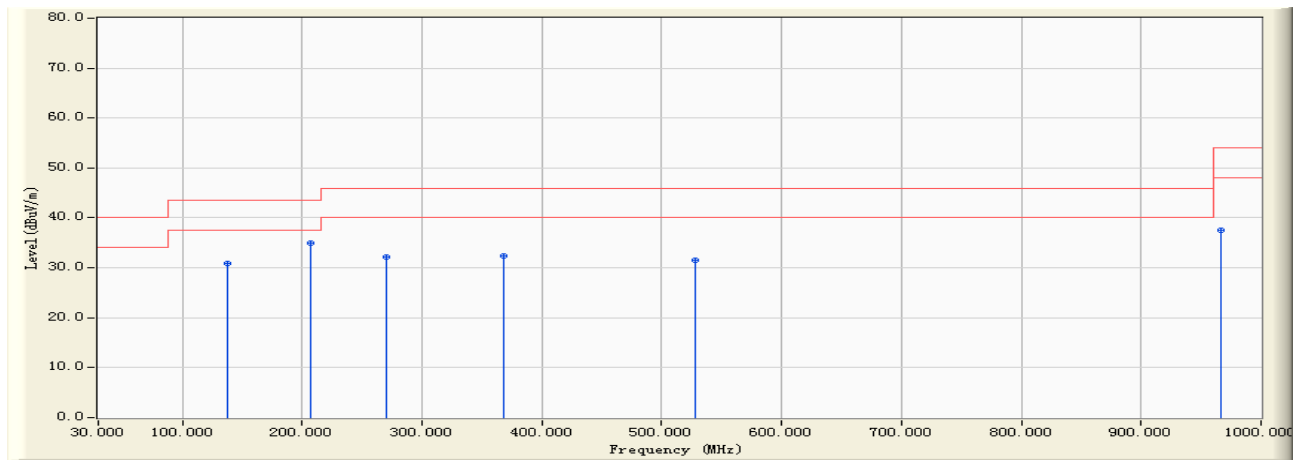

		Frequency (MHz)	Correct Factor (dB)	Reading Level (dBuV)	Measure Level (dBuV/m)	Margin (dB)	Limit (dBuV/m)	Detector Type
1		137.187	-17.387	48.320	30.933	-12.567	43.500	QUASPEAK
2	*	207.105	-17.267	52.180	34.912	-8.588	43.500	QUASPEAK
3		270.004	-13.967	46.170	32.203	-13.797	46.000	QUASPEAK
4		368.288	-11.359	43.760	32.402	-13.598	46.000	QUASPEAK
5		528.185	-8.525	40.150	31.625	-14.375	46.000	QUASPEAK
6		967.050	-0.864	38.470	37.606	-16.394	54.000	QUASPEAK

Note:

1. All Readings below 1GHz are Quasi-Peak, above are performed with peak and/or average measurements as necessary.
2. " * ", means this data is the worst emission level.
3. Measurement Level = Reading Level + Correct Factor



Engineer : Fred	
Site : EMC Lab AC 102	Time : 2010/02/05 - 15:07
Limit : FCC_CLASS_B_03M_QP	Margin : 6
EUT : LCD Monitor	Probe : HL562(30-1000MHz) - VERTICAL
Power : AC 120V/60Hz	Note : Mode 1: Full system (VGA mode 1920*1080@60Hz)

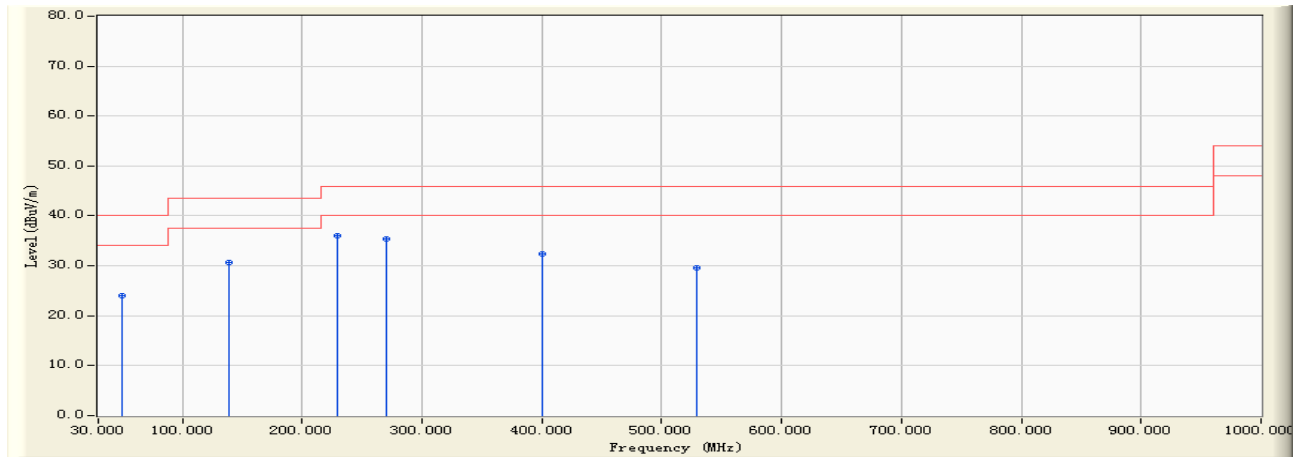

		Frequency (MHz)	Correct Factor (dB)	Reading Level (dBuV)	Measure Level (dBuV/m)	Margin (dB)	Limit (dBuV/m)	Detector Type
1		50.161	-19.278	43.250	23.971	-16.029	40.000	QUASPEAK
2		139.003	-17.521	48.270	30.749	-12.751	43.500	QUASPEAK
3	*	229.650	-16.057	52.160	36.102	-9.898	46.000	QUASPEAK
4		270.104	-13.962	49.320	35.358	-10.642	46.000	QUASPEAK
5		400.337	-10.820	43.120	32.299	-13.701	46.000	QUASPEAK
6		528.970	-8.520	38.160	29.640	-16.360	46.000	QUASPEAK

Note:

1. All Readings below 1GHz are Quasi-Peak, above are performed with peak and/or average measurements as necessary.
2. " * ", means this data is the worst emission level.
3. Measurement Level = Reading Level + Correct Factor



Above 1G:

Engineer : Fred	
Site : EMC Lab AC 102	Time : 2010/02/05 - 16:36
Limit : FCC_15_03M_PK	Margin : 6
EUT : LCD Monitor	Probe : BBHA9120D(1-18GHz) - HORIZONTAL
Power : AC 120V/60Hz	Note : Mode 1: Full system (VGA mode 1920*1080@60Hz)

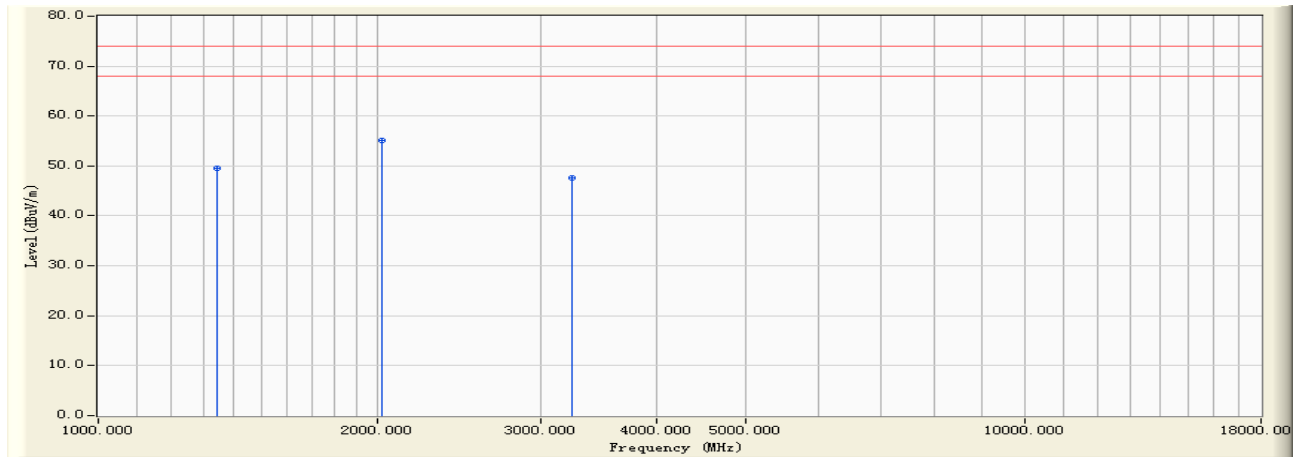

		Frequency (MHz)	Correct Factor (dB)	Reading Level (dBuV)	Measure Level (dBuV/m)	Margin (dB)	Limit (dBuV/m)	Detector Type
1		1341.900	-4.655	54.230	49.576	-24.424	74.000	PEAK
2	*	2026.870	-2.470	57.600	55.130	-18.870	74.000	PEAK
3		3246.190	1.248	46.320	47.569	-26.431	74.000	PEAK

Note:

1. All Readings below 1GHz are Quasi-Peak, above are performed with peak and/or average measurements as necessary.
2. " * ", means this data is the worst emission level.
3. Measurement Level = Reading Level + Correct Factor



Engineer : Fred	
Site : EMC Lab AC 102	Time : 2010/02/05 - 16:36
Limit : FCC_15_03M_AV	Margin : 6
EUT : LCD Monitor	Probe : BBHA9120D(1-18GHz) - HORIZONTAL
Power : AC 120V/60Hz	Note : Mode 1: Full system (VGA mode 1920*1080@60Hz)

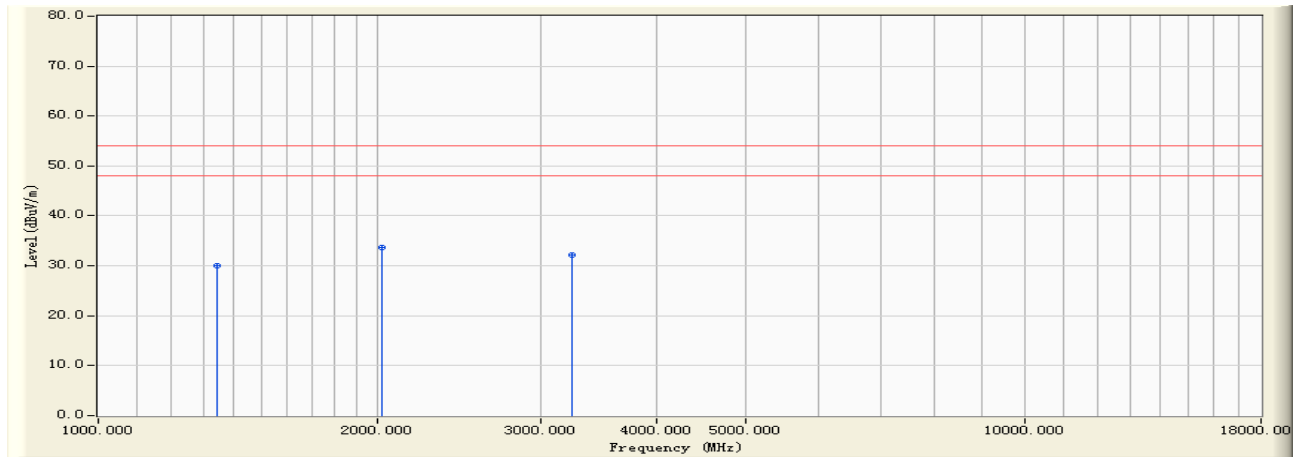

		Frequency (MHz)	Correct Factor (dB)	Reading Level (dBuV)	Measure Level (dBuV/m)	Margin (dB)	Limit (dBuV/m)	Detector Type
1		1341.900	-4.655	34.670	30.016	-23.984	54.000	AVERAGE
2	*	2026.870	-2.470	36.150	33.680	-20.320	54.000	AVERAGE
3		3246.190	1.248	30.870	32.119	-21.881	54.000	AVERAGE

Note:

1. All Readings below 1GHz are Quasi-Peak, above are performed with peak and/or average measurements as necessary.
2. " * ", means this data is the worst emission level.
3. Measurement Level = Reading Level + Correct Factor



Engineer : Fred	
Site : EMC Lab AC 102	Time : 2010/02/05 - 16:40
Limit : FCC_15_03M_PK	Margin : 6
EUT : LCD Monitor	Probe : BBHA9120D(1-18GHz) - VERTICAL
Power : AC 120V/60Hz	Note : Mode 1: Full system (VGA mode 1920*1080@60Hz)

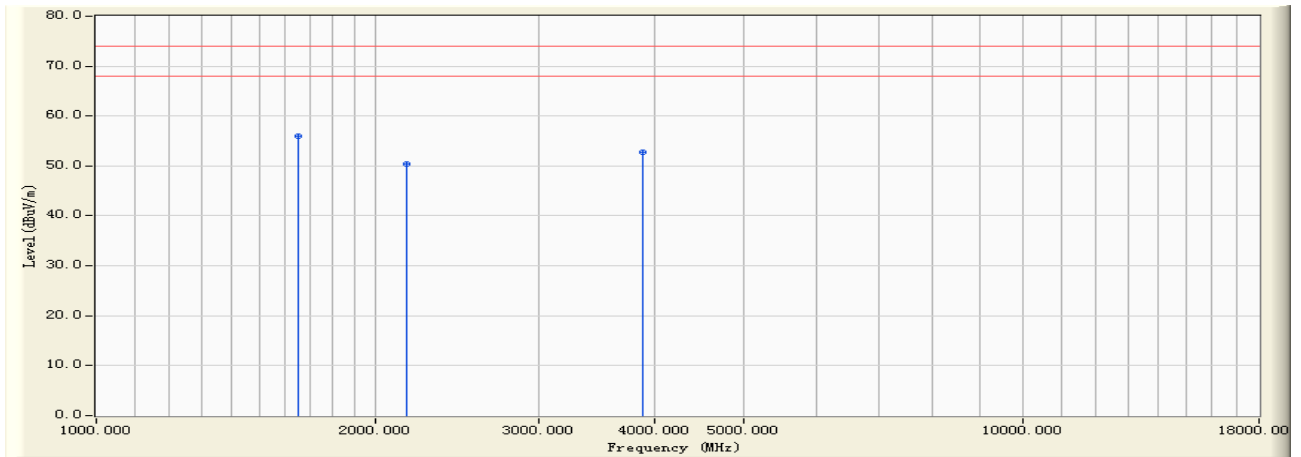

		Frequency (MHz)	Correct Factor (dB)	Reading Level (dBuV)	Measure Level (dBuV/m)	Margin (dB)	Limit (dBuV/m)	Detector Type
1	*	1651.370	-4.208	60.280	56.071	-17.929	74.000	PEAK
2		2161.070	-0.613	51.090	50.476	-23.524	74.000	PEAK
3		3895.210	4.087	48.740	52.828	-21.172	74.000	PEAK

Note:

1. All Readings below 1GHz are Quasi-Peak, above are performed with peak and/or average measurements as necessary.
2. " * ", means this data is the worst emission level.
3. Measurement Level = Reading Level + Correct Factor



Engineer : Fred	
Site : EMC Lab AC 102	Time : 2010/02/05 - 16:40
Limit : FCC_15_03M_AV	Margin : 6
EUT : LCD Monitor	Probe : BBHA9120D(1-18GHz) - VERTICAL
Power : AC 120V/60Hz	Note : Mode 1: Full system (VGA mode 1920*1080@60Hz)

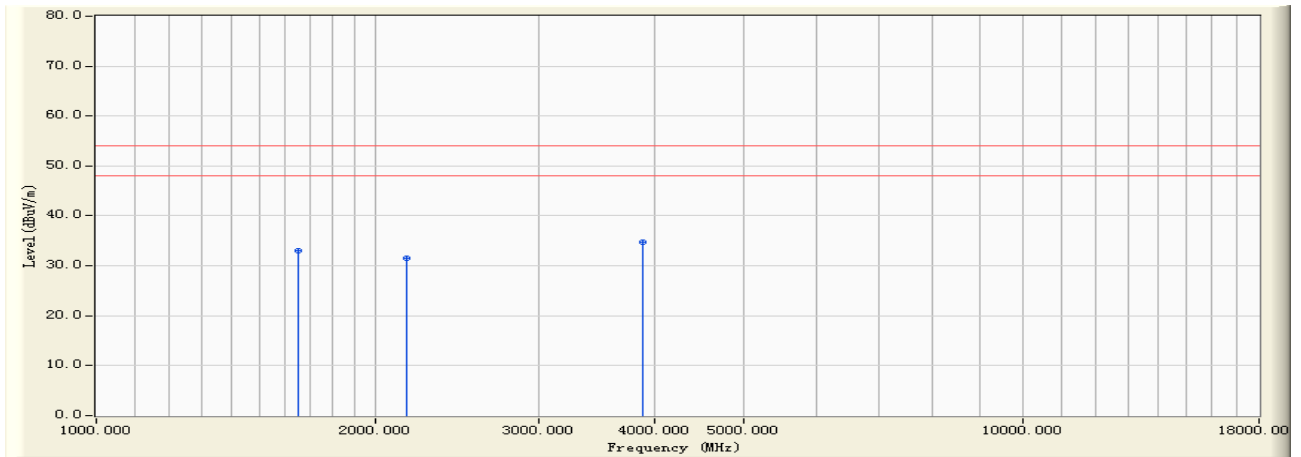

	Frequency (MHz)	Correct Factor (dB)	Reading Level (dBuV)	Measure Level (dBuV/m)	Margin (dB)	Limit (dBuV/m)	Detector Type
1	1651.370	-4.208	37.240	33.031	-20.969	54.000	AVERAGE
2	2161.070	-0.613	32.040	31.426	-22.574	54.000	AVERAGE
3	* 3895.210	4.087	30.740	34.828	-19.172	54.000	AVERAGE

Note:

1. All Readings below 1GHz are Quasi-Peak, above are performed with peak and/or average measurements as necessary.
2. " * ", means this data is the worst emission level.
3. Measurement Level = Reading Level + Correct Factor

Test engineer: Fred Guo