



FCC TEST REPORT

According to

47 CFR, Part 2, Part 15 and CISPR PUB. 22

Applicant	: LG Electronics USA
Address	: 1000 Sylvan Avenue Englewood Cliffs New Jersey United States
Manufacturer	: LG Electronics Nanjing Display Co., Ltd.
Address	: No.346, Yaoxin Road Economic & Technical Development Zone Nanjing China
Equipment	: LCD Monitor
Model No.	: E2211PUX
FCC ID	: BEJE2211PUX
Trade Name	: LG

- The test result refers exclusively to the test presented test model / sample.
- Without written approval of **CerpPASS Technology Corp.** the test report shall not be reproduced except in full.
- The test report must not be used by the clients to claim product certification approval by **NVLAP** or any agency of the Government.



Table of Contents

1. Summary of Test Procedure and Test Result	5
2. Test Configuration of Equipment under Test.....	6
2.1. Feature of Equipment under Test	6
2.2. Test Manner.....	6
2.3. Description of Test System	7
2.4. Connection Diagram of Test System	8
2.5. General Information of Test	9
2.6. Measurement Uncertainty	9
3. Test of Conducted Emission	10
3.1. Test Limit	10
3.2. Test Procedures.....	10
3.3. Typical test Setup	11
3.4. Measurement equipment.....	11
3.5. Test Result and Data	12
4. Test of Radiated Emission.....	13
4.1. Test Limit	13
4.2. Test Procedures.....	14
4.3. Typical test Setup	14
4.4. Measurement equipment.....	15
4.5. Test Result and Data	16



FCC TEST REPORT

According to

47 CFR, Part 2, Part 15 and CISPR PUB. 22

Applicant : LG Electronics USA

Address : 1000 Sylvan Avenue Englewood Cliffs New Jersey
United States

Manufacturer : LG Electronics Nanjing Display Co., Ltd.

Address : No.346, Yaoxin Road Economic & Technical
Development Zone Nanjing China

Equipment : LCD Monitor

Model No. : E2211PUX

FCC ID : BEJE2211PUX

Trade Name : LG

I **HEREBY** CERTIFY THAT :

The measurements shown in this test report were made in accordance with the procedures given in **ANSI C63.4 – 2003** and the energy emitted by this equipment was **passed CISPR PUB. 22 and FCC Part 15** in both radiated and conducted emission class B limits. Testing was carried out on Jan 19, 2011 at **CerpPASS Technology Corp.**

Documented By:

Approved By:

Cathy Chen/ Administration

Clinton Kao/ Technical director



1. Summary of Test Procedure and Test Result

Test Item	Normative References	Test Result
Conducted Emission	ANSI C63.4-2003 FCC Part 15 Subpart B	PASS
Radiated Emission	ANSI C63.4-2003 FCC Part 15 Subpart B	PASS



2. Test Configuration of Equipment under Test

2.1. Feature of Equipment under Test

LCD Monitor	Model No:	E2211PUX
VGA Cable	Shielded, 1.5m, with two ferrite cores bonded	
VGA Cable	Shielded, 1.5m	
DVI Cable	Shielded, 1.5m, with two ferrite cores bonded	
DVI Cable	Shielded, 1.5m	
Power Supply cable	Non-Shielded, 1.8m	
Note : The VGA Cable and DVI Cable are alternative on selling.		

2.2. Test Manner

Test Software	
a	During testing, the interface cables and equipment positions were varied according to ANSI C63.4.
b	The complete test system included the PC, USB Keyboard, USB Mouse, HDD, Printer and EUT for EMI test.
c	During the test, setup up the EUT and all system, turn on the power of all Equipments, run the EMC test software "H", set the contrast control to maximum, set the brightness control to maximum, use white letters on a black background to represent all colors, make the EUT at the test mode and it is normal operation, and then test.
The pre-test modes	
	Test Mode 1: Full system (DVI mode 1920*1080@60Hz)
	Test Mode 2: Full system (DVI mode 1280*1024@75Hz)
	Test Mode 3: Full system (DVI mode 800*600@60Hz)
	Test Mode 4: Full system (VGA mode 1920*1080@60Hz)
	Test Mode 5: Full system (VGA mode 1280*1024@75Hz)
	Test Mode 6: Full system (VGA mode 800*600@60Hz)
Select the worst case of the pre-test modes as the final test mode	
	Test Mode 1: Full system (DVI mode 1920*1080@60Hz)



2.3. Description of Test System

No	Device	Manufacturer	Model No.	Description
1	PC	Dell	DCSM	N/A
2	USB Keyboard	DELL	SK-8115	N/A
3	USB Mouse	DELL	G0K02XYK	N/A
4	HDD	TOSHIBA	SN05-11005	N/A
5	HDD	TOSHIBA	SN05-11002	N/A
6	Printer	Epson	EX3	N/A



2.4. Connection Diagram of Test System

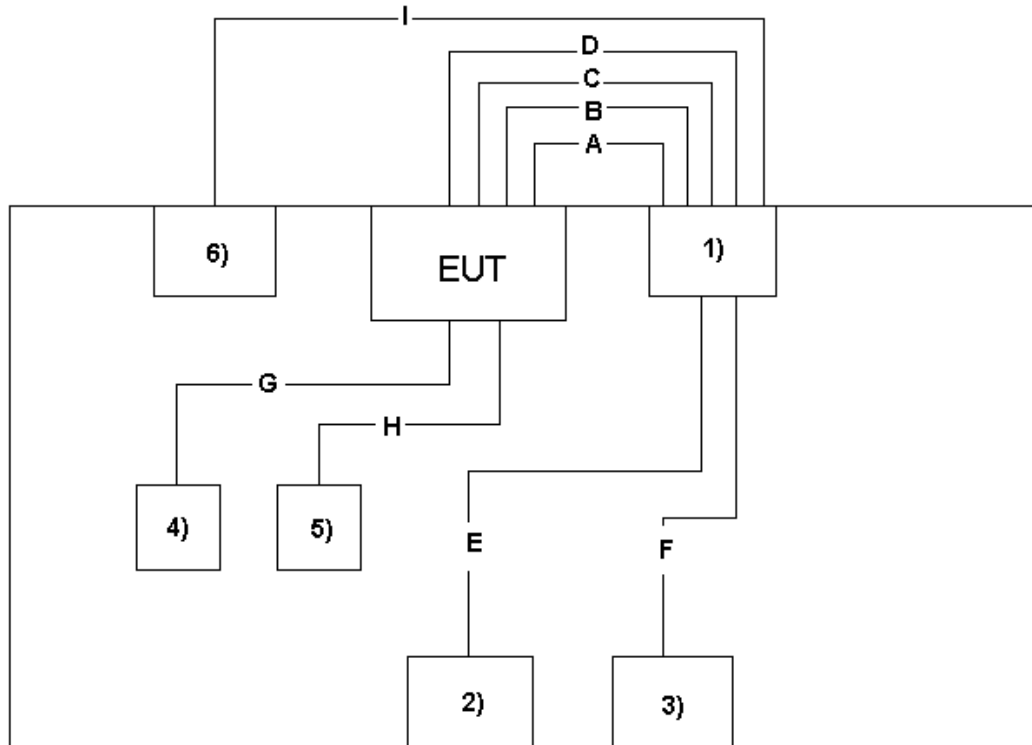

No	Cable	Quantity	Description
A	VGA Cable	1	Shielded, 1.5m
B	DVI Cable	1	Shielded, 1.5m
C	USB Cable	1	Shielded, 1.8m
C	Audio Cable	1	Non-Shielded, 1.5m
D	USB Cable	1	Shielded, 1.8m, with one ferrite core bonded
E	USB Cable	1	Shielded, 1.5m
F	USB Cable	1	Shielded, 0.5m
G	USB Cable	1	Shielded, 0.5m
H	Parallel Cable	1	Shielded, 1.8m



2.5. General Information of Test

Test Site:	CerpPASS Technology Corp.
Performand Location :	No.66,Tangzhuang Road, Suzhou Industrial Park, Jiangsu 215006, China
NVLAP LAB Code :	200814-0
FCC Registration Number :	916572, 331395
IC Registration Number :	7290A-1, 7290A-2
VCCI Registration Number :	T-343 for Telecommunication Test C-2919 for Conducted emission test R-2670 for Radiated emission test below 1GHz G-227 for Radiated emission test above 1GHz
Frequency Range Investigated :	Conducted Emission Test: from 150kHz to 30 MHz Radiated Emission Test: from 30 MHz to 1,000 MHz Radiated Emission Test: from 1GHz to 18GHz
Test Distance :	The test distance of radiated emission below 1GHz from antenna to EUT is 3 M. The test distance of radiated emission above 1GHz from antenna to EUT is 3 M.

Laboratory accreditation



2.6. Measurement Uncertainty

Conducted Emission		
The measurement uncertainty is evaluated as ± 2.71 dB.		
Radiated Emission		
(30MHz -1000MHz)	Horizontal	The measurement uncertainty is evaluated as ±3.89dB.
	Vertical	The measurement uncertainty is evaluated as ± 3.59 dB.
(1G-18GHz)	Horizontal	The measurement uncertainty is evaluated as ± 2.31 dB.
	Vertical	The measurement uncertainty is evaluated as ± 2.15 dB.



3. Test of Conducted Emission

3.1. Test Limit

Conducted Emissions were measured from 150 kHz to 30 MHz with a bandwidth of 9 KHz on the 120 VAC power and return leads of the EUT according to the methods defined in ANSI C63.4-2003 Section 3.1. The EUT was placed on a nonmetallic stand in a shielded room 0.8 meters above the ground plane as shown in section 2.2. The interface cables and equipment positioning were varied within limits of reasonable applications to determine the position produced maximum conducted emissions.

Frequency (MHz)	Quasi Peak (dB μ V)	Average (dB μ V)
0.15 – 0.5	66-56*	56-46*
0.5 – 5.0	56	46
5.0 – 30.0	60	50

3.2. Test Procedures

- a. The EUT was placed 0.4 meter from the conducting wall of the shielding room was kept at least 80 centimeters from any other grounded conducting surface.
- b. Connect EUT to the power mains through a line impedance stabilization network (LISN).
- c. All the support units are connecting to the other LISN.
- d. The LISN provides 50 ohm coupling impedance for the measuring instrument.
- e. The FCC states that a 50 ohm, 50 micro-Henry LISN should be used.
- f. Both sides of AC line were checked for maximum conducted interference.
- g. The frequency range from 150 kHz to 30 MHz was searched.
- h. Set the test-receiver system to Peak Detect Function and Specified Bandwidth with Maximum Hold Mode.



3.5. Test Result and Data

Test Mode :	Mode 1: Full system (DVI mode 1920*1080@60Hz)		
AC Power :	AC 120V/60Hz	Phase :	L&N
EUT :	LCD Monitor	Model No.:	E2211PUX
Temperature :	22°C	Humidity :	50%
Pressur(mbar) :	1002	Date :	2011/01/17

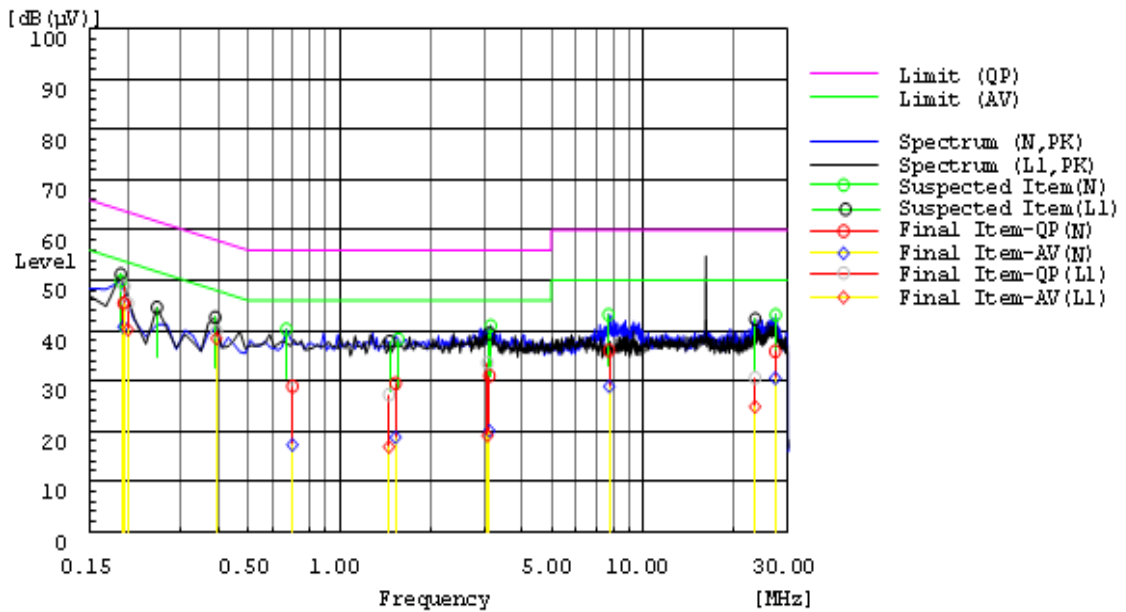

Frequency MHz	Line Phase	Reading dB(uV) QP	Reading dB(uV) AV	Factor dB	Level dB(uV) QP	Level dB(uV) AV	Limit dB(uV) QP	Limit dB(uV) AV	Margin dB QP	Margin dB AV	Pass/Fail
0.19472	L1	29.0	25.6	19.9	48.9	45.5	63.8	53.8	15.0	8.3	Pass
0.20024	L1	25.5	20.3	19.9	45.4	40.2	63.6	53.6	18.2	13.4	Pass
0.39231	L1	20.0	18.5	19.9	39.9	38.4	58.0	48.0	18.1	9.6	Pass
1.45513	L1	7.5	-2.9	19.7	27.2	16.8	56.0	46.0	28.8	29.2	Pass
3.07663	L1	13.9	-0.6	19.7	33.6	19.1	56.0	46.0	22.4	26.9	Pass
23.4604	L1	11.0	5.3	19.6	30.6	24.9	60.0	50.0	29.4	25.1	Pass
0.19373	N	25.9	21.3	19.5	45.4	40.8	63.9	53.9	18.5	13.1	Pass
27.3652	N	16.1	10.7	19.8	35.9	30.5	60.0	50.0	24.1	19.5	Pass
7.7475	N	16.3	9.2	19.7	36.0	28.9	60.0	50.0	24.0	21.1	Pass
3.12017	N	11.4	0.5	19.6	31.0	20.1	56.0	46.0	25.0	25.9	Pass
1.52861	N	10.0	-0.7	19.5	29.5	18.8	56.0	46.0	26.5	27.2	Pass
0.69924	N	9.4	-2.3	19.5	28.9	17.2	56.0	46.0	27.1	28.8	Pass

Note: Measurement Level = Reading Level + Correct Factor

Test engineer: Seben



4. Test of Radiated Emission

4.1. Test Limit

Radiated emissions from 30 MHz to 1,000 MHz were measured with a bandwidth of 120 kHz according to the methods defines in ANSI C63.4-2003. The EUT was placed on a nonmetallic stand in the open-field site, 0.8 meter above the ground plane, as shown in section 3.2. The interface cables and equipment positions were varied within limits of reasonable applications to determine the positions producing maximum radiated emissions.

For unintentional device, according to § 15.109(a), except for Class A digital devices, the field strength of radiated emissions from unintentional radiators at a distance of 3 meters shall not exceed the following values:

Frequency (MHz)	Distance (m)	Level (dBuV/m)	Level (dBuV/m)
30 - 88	3	40(QP)	N/A
88 - 216	3	43(QP)	N/A
216-960	3	46(QP)	N/A
960-1000	3	54(QP)	N/A
1000-18000	3	74(PK)	54(AV)

For unintentional device, according to CISPR PUB.22, for Class B digital devices, the general requirement of field strength of radiated emissions from intentional radiators at a distance of 10 meters shall not exceed the below table.

Frequency (MHz)	Distance Meters	Radiated (dB μ V/ M)
30-230	10	30
230-1000	10	37



4.2. Test Procedures

- a. The EUT was placed on a Rota table top 0.8 meter above ground.
- b. The EUT and its simulators are placed on the ground. The turn table can rotate 360 degrees to determine the position of the maximum emission level. The EUT was positioned such that the distance from antenna to the EUT was 3 meters.
- c. The antenna can move up and down between 1 meter and 4 meters to find out the maximum emission level.
- d. Both horizontal and vertical polarization of the antenna are set on measurement. In order to find the maximum emission, all of the interface cables must be manipulated on radiated measurement.
- e. Radiated emissions were investigated over the frequency range from 30MHz to 1GHz using a receiver bandwidth of 120KHz and the frequency range from 1GHz to 18GHz using a receiver bandwidth of 1MHz.

4.3. Typical test Setup

Below 1GHz Test Setup

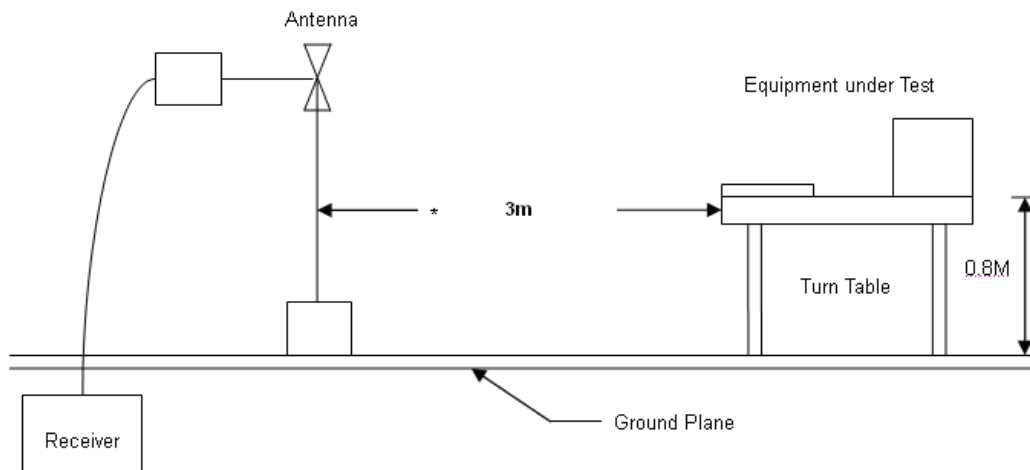



Above 1GHz Test Setup

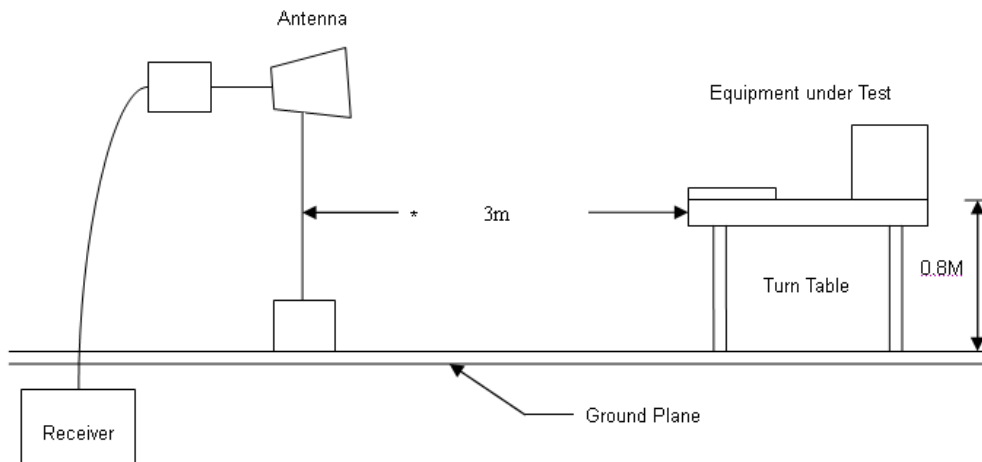

4.4. Measurement equipment

Instrument	Model No.	Manufacturer	Serial No.	Calibration Date
EMI Test Receiver	R&S	ESCI	100563	2010.06.23
H64 Amplifier	HP	8447F	3113A05582	2010.08.14
Preamplifier	Agilent	8449B	ED-HE-EMI-077	2010.02.10
Ultra Broadband Antenna	R&S	HL562	100363	2010.08.14
Broad-Band Horn Antenna	Schwarzbeck	BBHA9120D	9120D-619	2010.08.14
Spectrum Analyzer	R&S	FSP40	100324	2010.08.14
Temperature/ Humidity Meter	Zhicheng	ZC1-11	CEP-TH-002	2010.08.17



4.5. Test Result and Data

Under 1G:

Engineer : Seven	
Site : EMC Lab AC 102	Time : 2011/01/19 - 21:23
Limit : FCC_CLASS_B_03M_QP	Margin : 6
EUT : LCD Monitor	Probe : HL562(30-1000MHz) - HORIZONTAL
Power : AC 120V/60Hz	Note : Mode 1: Full system (DVI mode 1920*1080@60Hz)

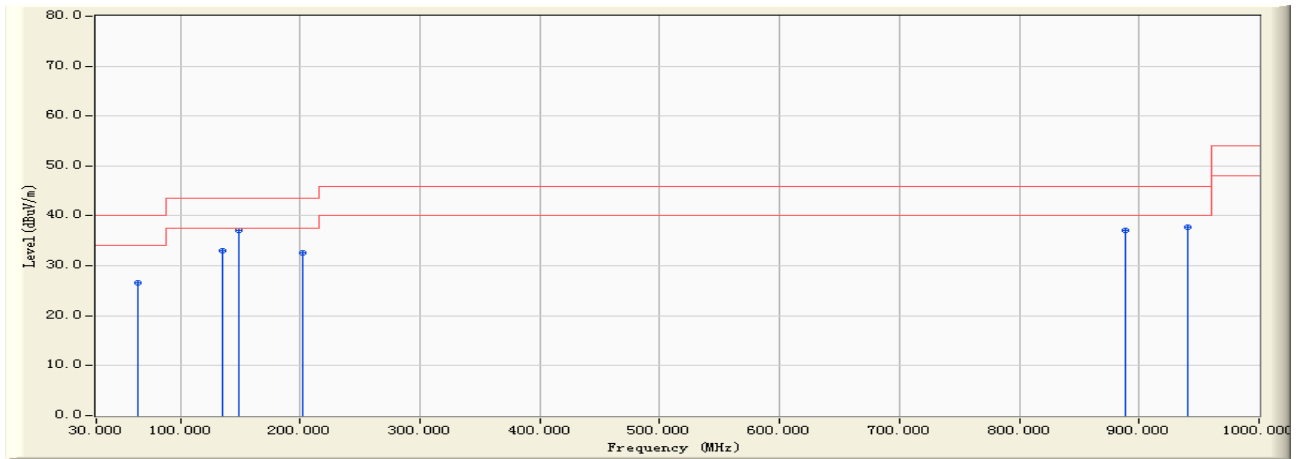

	Frequency (MHz)	Correct Factor (dB)	Reading Level (dBuV)	Measure Level (dBuV/m)	Margin (dB)	Limit (dBuV/m)	Detector Type	Ant Pos (cm)	Table Pos (deg)
1	65.230	-21.639	48.200	26.561	-13.439	40.000	QUASIPeAK	200.000	36.200
2	135.250	-17.241	50.240	32.999	-10.501	43.500	QUASIPeAK	200.000	89.500
3	* 148.500	-17.888	54.900	37.011	-6.489	43.500	QUASIPeAK	200.000	332.000
4	202.320	-17.615	50.210	32.596	-10.904	43.500	QUASIPeAK	200.000	66.300
5	889.120	-2.300	39.500	37.200	-8.800	46.000	QUASIPeAK	100.000	159.000
6	940.120	-0.742	38.400	37.658	-8.342	46.000	QUASIPeAK	200.000	125.000

Note:

1. All Readings below 1GHz are Quasi-Peak, above are performed with peak and/or average measurements as necessary.
2. " * ", means this data is the worst emission level.
3. Measurement Level = Reading Level + Correct Factor



Engineer : Seven	
Site : EMC Lab AC 102	Time : 2011/01/19 - 21:24
Limit : FCC_CLASS_B_03M_QP	Margin : 6
EUT : LCD Monitor	Probe : HL562(30-1000MHz) - VERTICAL
Power : AC 120V/60Hz	Note : Mode 1: Full system (DVI mode 1920*1080@60Hz)

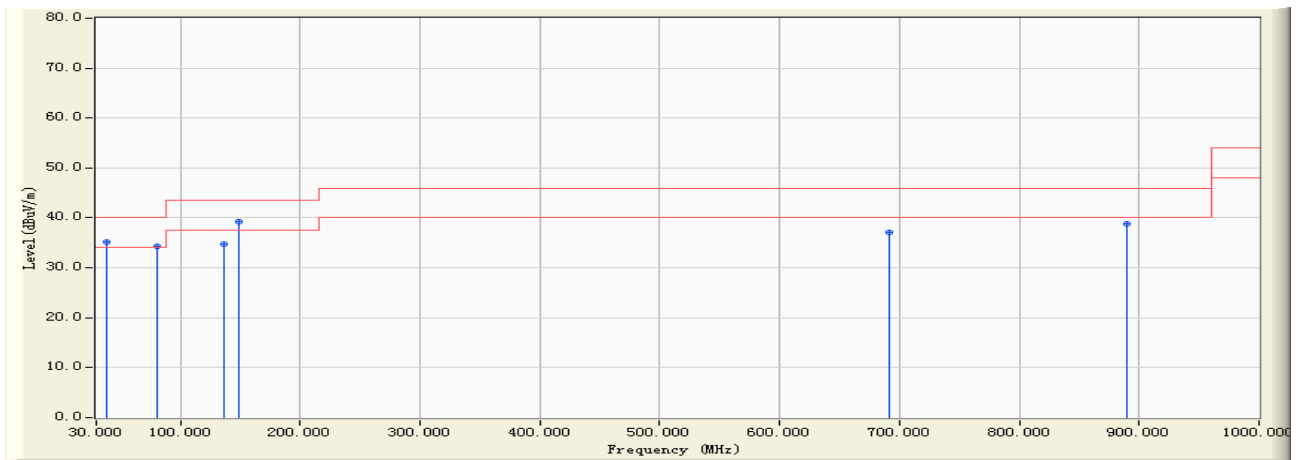

	Frequency (MHz)	Correct Factor (dB)	Reading Level (dBuV)	Measure Level (dBuV/m)	Margin (dB)	Limit (dBuV/m)	Detector Type	Ant Pos (cm)	Table Pos (deg)
1	39.260	-12.730	48.000	35.270	-4.730	40.000	QUASIPeAK	100.000	152.000
2	81.250	-18.081	52.310	34.230	-5.770	40.000	QUASIPeAK	100.000	89.400
3	136.230	-17.317	52.100	34.783	-8.717	43.500	QUASIPeAK	100.000	39.500
4	* 148.500	-17.888	57.200	39.311	-4.189	43.500	QUASIPeAK	100.000	10.000
5	691.250	-5.174	42.300	37.126	-8.874	46.000	QUASIPeAK	100.000	65.200
6	890.210	-2.303	41.200	38.897	-7.103	46.000	QUASIPeAK	100.000	89.400

Note:

1. All Readings below 1GHz are Quasi-Peak, above are performed with peak and/or average measurements as necessary.
2. " * ", means this data is the worst emission level.
3. Measurement Level = Reading Level + Correct Factor



Above 1G:

Engineer : Seven	
Site : EMC Lab AC 102	Time : 2011/01/19 - 21:53
Limit : FCC_15_03M_PK	Margin : 6
EUT : LCD Monitor	Probe : BBHA9120D(1-18GHz) - HORIZONTAL
Power : AC 120V/60Hz	Note : Mode 1: Full system (DVI mode 1920*1080@60Hz)

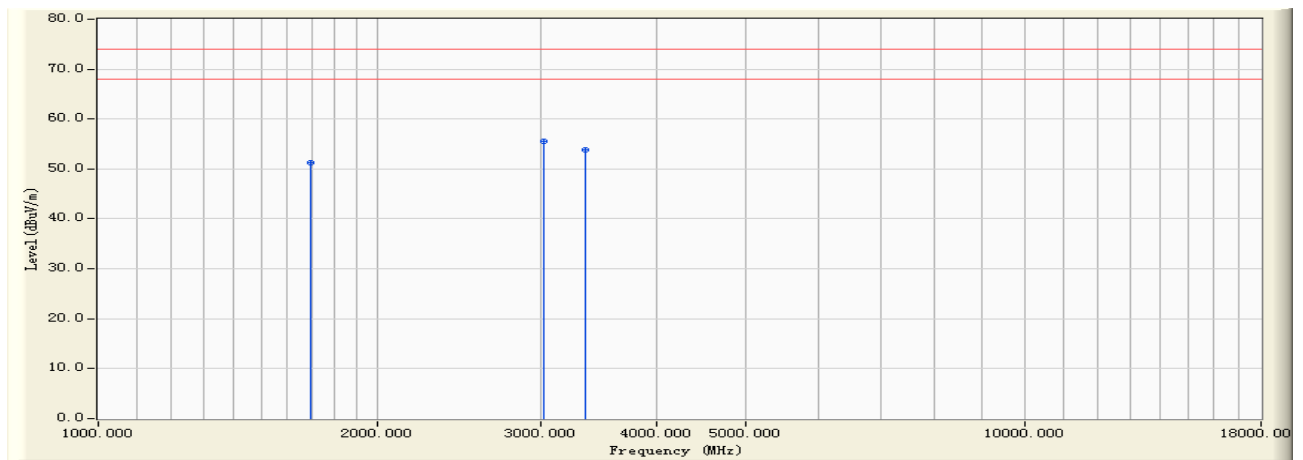

	Frequency (MHz)	Correct Factor (dB)	Reading Level (dBuV)	Measure Level (dBuV/m)	Margin (dB)	Limit (dBuV/m)	Detector Type	Ant Pos (cm)	Table Pos (deg)
1	1693.620	-3.991	55.300	51.309	-22.691	74.000	PEAK	200.000	48.500
2	* 3025.600	1.952	53.620	55.572	-18.428	74.000	PEAK	100.000	158.400
3	3354.210	1.997	51.830	53.827	-20.173	74.000	PEAK	100.000	96.800

Note:

1. All Readings below 1GHz are Quasi-Peak, above are performed with peak and/or average measurements as necessary.
2. " * ", means this data is the worst emission level.
3. Measurement Level = Reading Level + Correct Factor



Engineer : Seven	
Site : EMC Lab AC 102	Time : 2011/01/19 - 21:53
Limit : FCC_15_03M_AV	Margin : 6
EUT : LCD Monitor	Probe : BBHA9120D(1-18GHz) - HORIZONTAL
Power : AC 120V/60Hz	Note : Mode 1: Full system (DVI mode 1920*1080@60Hz)

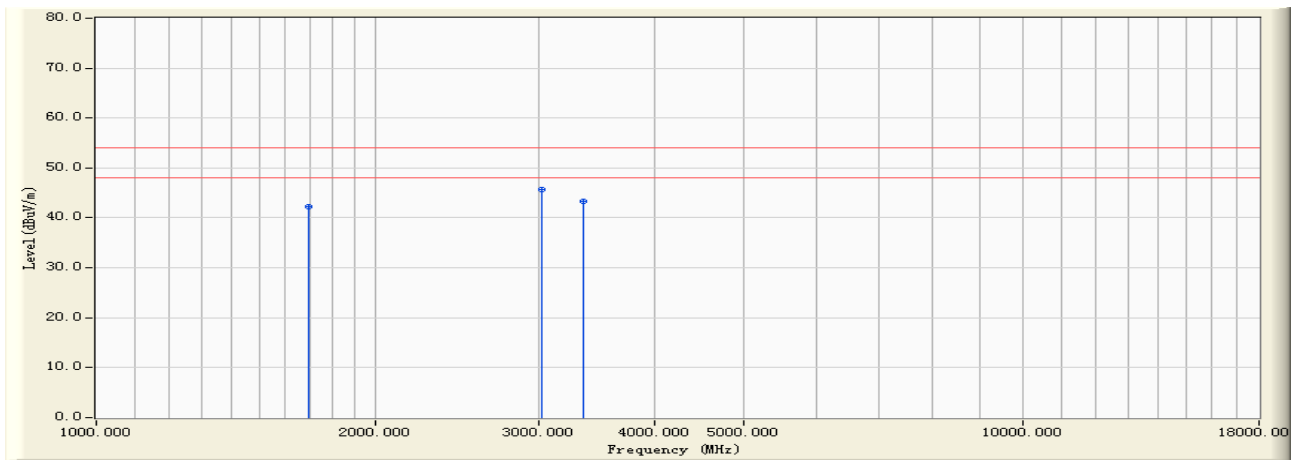

	Frequency (MHz)	Correct Factor (dB)	Reading Level (dBuV)	Measure Level (dBuV/m)	Margin (dB)	Limit (dBuV/m)	Detector Type	Ant Pos (cm)	Table Pos (deg)
1	1693.620	-3.991	46.200	42.209	-11.791	54.000	AVERAGE	200.000	48.500
2	* 3025.600	1.952	43.800	45.752	-8.248	54.000	AVERAGE	100.000	158.400
3	3354.210	1.997	41.420	43.417	-10.583	54.000	AVERAGE	100.000	96.800

Note:

1. All Readings below 1GHz are Quasi-Peak, above are performed with peak and/or average measurements as necessary.
2. " * ", means this data is the worst emission level.
3. Measurement Level = Reading Level + Correct Factor



Engineer : Seven	
Site : EMC Lab AC 102	Time : 2011/01/19 - 21:55
Limit : FCC_15_03M_PK	Margin : 6
EUT : LCD Monitor	Probe : BBHA9120D(1-18GHz) - VERTICAL
Power : AC 120V/60Hz	Note : Mode 1: Full system (DVI mode 1920*1080@60Hz)

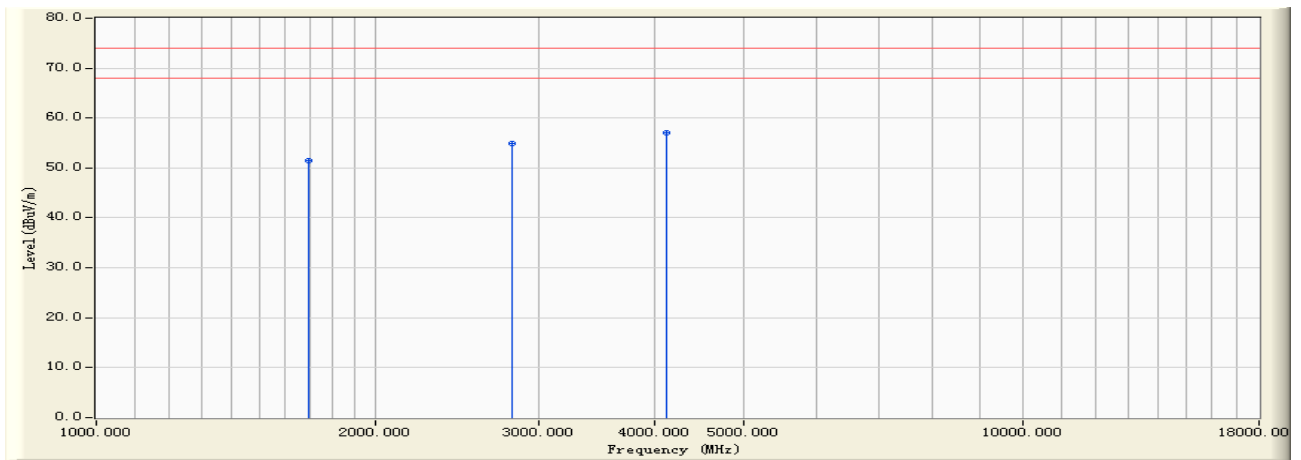

	Frequency (MHz)	Correct Factor (dB)	Reading Level (dBuV)	Measure Level (dBuV/m)	Margin (dB)	Limit (dBuV/m)	Detector Type	Ant Pos (cm)	Table Pos (deg)
1	1695.200	-3.992	55.400	51.408	-22.592	74.000	PEAK	100.000	152.000
2	2815.600	1.368	53.600	54.968	-19.032	74.000	PEAK	100.000	254.000
3	* 4121.600	5.116	51.980	57.097	-16.903	74.000	PEAK	100.000	66.700

Note:

1. All Readings below 1GHz are Quasi-Peak, above are performed with peak and/or average measurements as necessary.
2. " * ", means this data is the worst emission level.
3. Measurement Level = Reading Level + Correct Factor



Engineer : Seven	
Site : EMC Lab AC 102	Time : 2011/01/19 - 21:55
Limit : FCC_15_03M_AV	Margin : 6
EUT : LCD Monitor	Probe : BBHA9120D(1-18GHz) - VERTICAL
Power : AC 120V/60Hz	Note : Mode 1: Full system (DVI mode 1920*1080@60Hz)

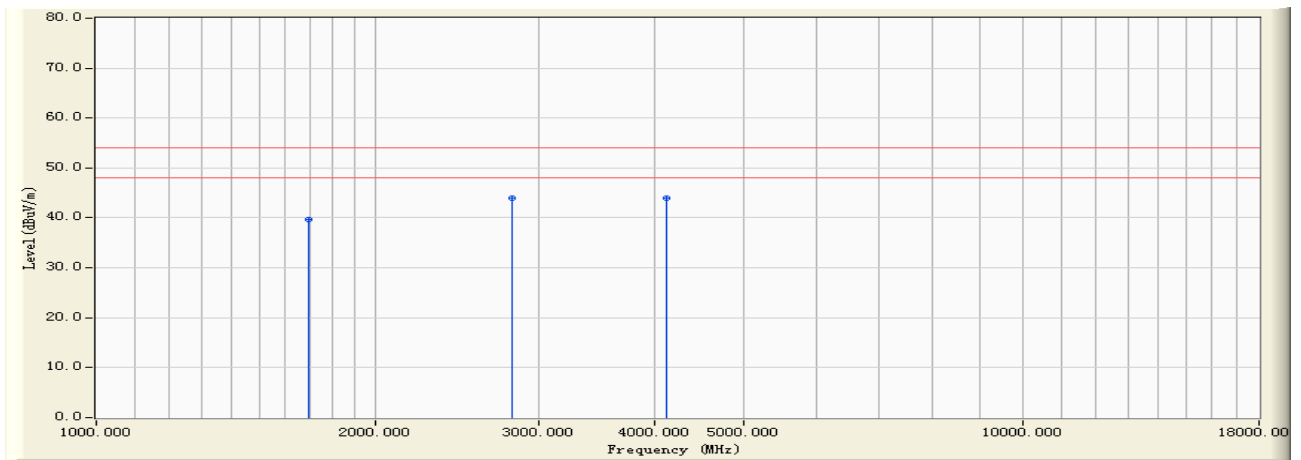

	Frequency (MHz)	Correct Factor (dB)	Reading Level (dBuV)	Measure Level (dBuV/m)	Margin (dB)	Limit (dBuV/m)	Detector Type	Ant Pos (cm)	Table Pos (deg)
1	1695.200	-3.992	43.650	39.658	-14.342	54.000	AVERAGE	100.000	152.000
2	2815.600	1.368	42.510	43.878	-10.122	54.000	AVERAGE	100.000	254.000
3	* 4121.600	5.116	38.800	43.917	-10.083	54.000	AVERAGE	100.000	66.700

Note:

1. All Readings below 1GHz are Quasi-Peak, above are performed with peak and/or average measurements as necessary.
2. " * ", means this data is the worst emission level.
3. Measurement Level = Reading Level + Correct Factor

Test engineer: Seven