

Application for FCC Certificate
On Behalf of
LG Electronics U.S.A., Inc.

LCD Monitor

Model No.: E2210PW

Serial No.: 009NDBP56557

FCC ID : BEJE2210PW

Prepared For : LG Electronics U.S.A., Inc.
1000 Sylvan Avenue, Englewood Cliffs,
NJ 07632, United States

Prepared By : Audix Technology (Shanghai) Co., Ltd.
3F 34Bldg 680 Guiping Rd,
Caohejing Hi-Tech Park,
Shanghai 200233, China

Tel: +86-21-64955500
Fax: +86-21-64955491

Report No. : ACI-F10128
Date of Test : Sep 19 – 20, 2010
Date of Report : Sep 26, 2010

TABLE OF CONTENTS

	Page
1 SUMMARY OF STANDARDS AND RESULTS.....	4
1.1 Description of Standards and Results.....	4
2 GENERAL INFORMATION.....	5
2.1 Description of Equipment Under Test.....	5
2.2 Peripherals.....	6
2.3 Description of Test Facility.....	7
2.4 Measurement Uncertainty.....	7
3 CONDUCTED EMISSION TEST.....	8
3.1 Test Equipment.....	8
3.2 Block Diagram of Test Setup.....	8
3.3 Conducted Emission Limit [FCC Part 15 Subpart B 15.107(a)].....	9
3.4 Test Configuration.....	9
3.5 Operating Condition of EUT.....	10
3.6 Test Procedures.....	10
3.7 Test Results.....	11
4 RADIATED EMISSION TEST.....	18
4.1 Test Equipment.....	18
4.2 Block Diagram of Test Setup.....	18
4.3 Radiated Emission Limit [FCC Part 15 Subpart B 15.109(a)].....	19
4.4 Test Configuration.....	19
4.5 Operating Condition of EUT.....	20
4.6 Test Procedures.....	20
4.7 Test Results.....	21
5 DEVIATION TO TEST SPECIFICATIONS.....	33
6 DEBUG DESCRIPTION.....	34

1 SUMMARY OF STANDARDS AND RESULTS

1.1 Description of Standards and Results

The EUT have been tested according to the applicable standards as referenced below:

Description of Test Item	Standard	Limits	Results
EMISSION			
Conducted Disturbance at the Mains Terminal	FCC RULES AND REGULATIONS PART 15 SUBPART B OCTOBER 2009 AND ANSI C63.4-2003	15.107(a) Class B	Pass
Radiated Disturbance	FCC RULES AND REGULATIONS PART 15 SUBPART B OCTOBER 2009 AND ANSI C63.4-2003	15.109(a) Class B	Pass

2 GENERAL INFORMATION

2.1 Description of Equipment Under Test

Description	: LCD Monitor
Type of EUT	: <input checked="" type="checkbox"/> Production <input type="checkbox"/> Pre-product <input type="checkbox"/> Pro-type
Model No.	: E2210PW
Serial No.	: 009NDBP56557
Real Power	: 26.20W
Note	: The data of E2210PW at rotate 90 degree condition (only radiated emission) was also tested and recorded in this report. The mode tested was the worst case of E2210PW in normal condition.
Applicant	: LG Electronics U.S.A., Inc. 1000 Sylvan Avenue, Englewood Cliffs, NJ 07632, United States
Manufacturer	: LG Electronics Nanjing Display Co., Ltd. No.346, Yao Xin Road, Economic & Technical Development Zone, Nanjing, China
LCD Panel	: Manufacturer: LG Display M/N : LM220WE5 (TL) (C1)
Max Resolution	: 1680*1050@60Hz
D-Sub Cable #1	: Shielded, Detachable, 1.85m, with two cores on cable
D-Sub Cable #2	: Shielded, Detachable, 1.85m, with two cores in connector
DVI Cable #1	: Shielded, Detachable, 1.85m, with two cores on cable
DVI Cable #2	: Shielded, Detachable, 1.85m, with two cores in connector
Power Cord	: Unshielded, Detachable, 1.80m
Note	: After evaluation, the D-Sub cable#1 and DVI cable#1 were used in the test for they will cause the maximum emission.

Remark:

The EUT is a LCD Monitor which input/output ports as follows:

- (1) One D-Sub Port : Connected with PC
- (2) One DVI Port : Connected with PC
- (3) One AC In Port : Connected with Power

2.2 Peripherals

2.2.1 PC

Manufacturer : HP
Model Number : dx7400MT
Serial Number : CNG8130K89
Power Cord : Unshielded, Detachable, 1.8m
Certificate : FCC DoC; CE/EMC; VCCI; C-Tick; UL
BSMI (R33001) 3C (A000111)
MIC (E-A011-04-2659(B))

2.2.2 Printer

Manufacturer : HP
Model Number : C3990A
Serial Number : JPZX020487
Data Cable : Shielded, Detachable, 1.5m
Certificate : GS, CE/EMC, C-Tick, FCC DoC

2.2.3 Keyboard

Manufacturer : Microsoft
Model Number : KU-0459
Serial Number : 7691402450604
Data Cable : Shielded, Undetachable, 1.8m
Certificate : CE/EMC, FCC DoC, VCCI, MIC,
C-Tick, BSMI

2.2.4 Mouse

Manufacturer : DELL
Model Number : MO56UO
Serial Number : 443048231
Data Cable : Shielded, Undetachable, 1.8m.
Certificate : CE/EMC, FCC DoC, VCCI, MIC,
C-Tick, BSMI

2.2.5 Modem

Manufacturer : TP-LINK
Model Number : TM-EC5658V
Serial Number : 07123301053
Data Cable : Shielded, Detachable, 1.8m
Certificate : FCC DoC, CE/EMC, CCC

2.3 Description of Test Facility

Site Description (Semi-Anechoic Chamber)	:	Sept. 17, 1998 file on Apr 29, 2009 Renewed Federal Communications Commission FCC Engineering Laboratory 7435 Oakland Mills Road Columbia, MD 21046, USA
Name of Firm	:	Audix Technology (Shanghai) Co., Ltd.
Site Location	:	3F 34Bldg 680 Guiping Rd, Caohejing Hi-Tech Park, Shanghai 200233, China
NVLAP Lab Code	:	200371-0

2.4 Measurement Uncertainty

Conducted Emission Expanded Uncertainty:	U = 1.26 dB
Radiated Emission Expanded Uncertainty :	U = 3.02 dB

3 CONDUCTED EMISSION TEST

3.1 Test Equipment

The following test equipments are used during the conducted emission test in a shielded room:

Item	Type	Manufacturer	Model No.	Serial No.	Last Cal.	Next Cal.
1.	Test Receiver	R&S	ESCI	100841	Oct 15, 2009	Oct 15, 2010
2.	Artificial Mains Network (AMN)	R&S	ESH2-Z5	843890/011	Apr 02, 2010	Apr 02, 2011
3.	Line Impedance Stabilization Network (LISN)	Kyoritsu	KNW-407	8-1280-4	Apr 02, 2010	Apr 02, 2011
4.	50 Ω Coaxial Switch	Anritsu	MP59B	6200426389	Mar 19, 2010	Sep 19, 2010
5.	50Ω Terminator	Anritsu	BNC	001	Apr 02, 2010	Apr 02, 2011
6.	Software	Audix	E3	SET00200 9804M592	--	--

3.2 Block Diagram of Test Setup

3.2.1 EUT & Peripherals

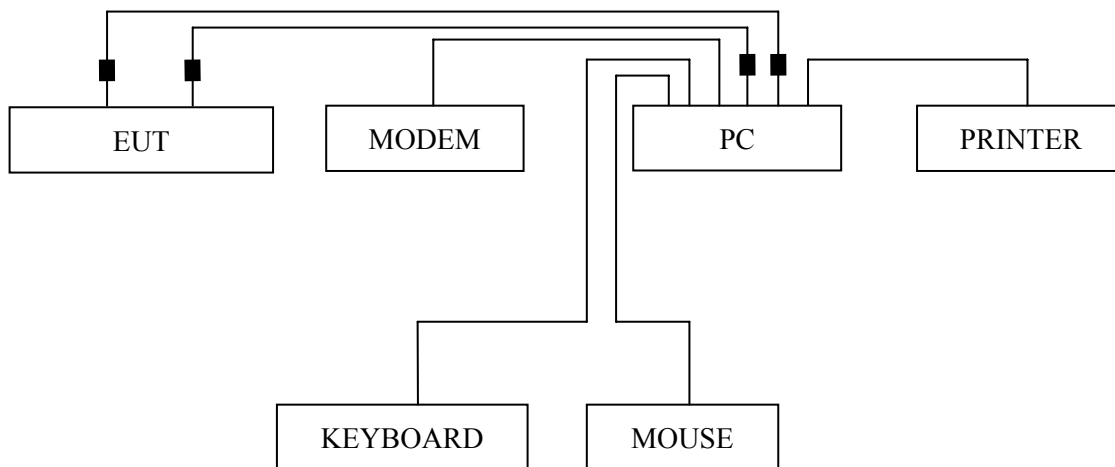

■ : Ferrite core

3.2.2 Conducted Disturbance Test Setup

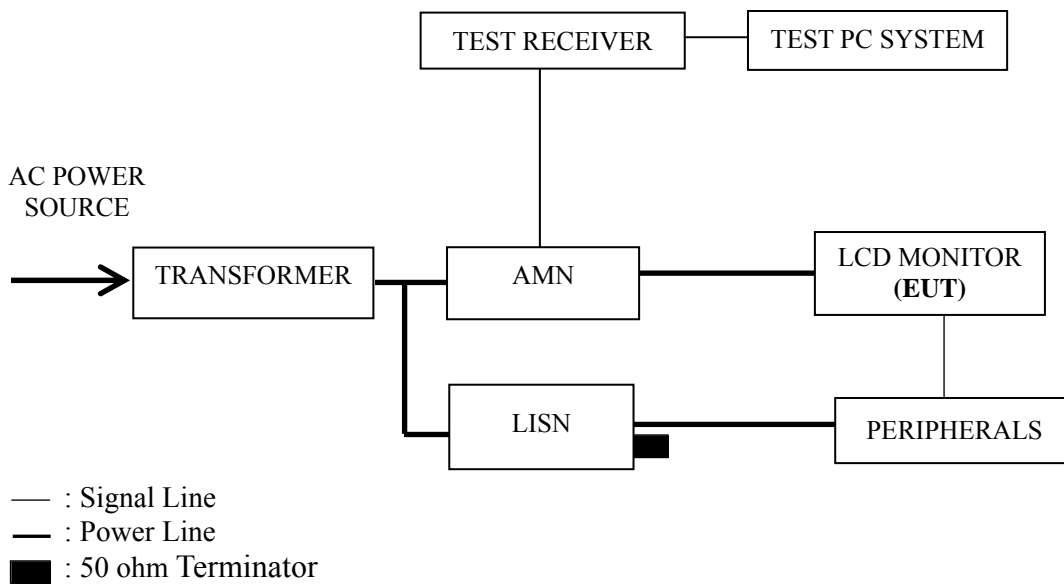

3.3 Conducted Emission Limit [FCC Part 15 Subpart B 15.107(a)]

Frequency Range (MHz)	Limits dB (μ V)	
	Quasi-peak	Average
0.15 ~ 0.5	66~56	56~46
0.5 ~ 5	56	46
5 ~ 30	60	50

NOTE 1 – The lower limit shall apply at the transition frequencies.
 NOTE 2 – The limit decreases linearly with the logarithm of the frequency in the range 0.15 MHz~0.50 MHz

3.4 Test Configuration

The EUT (listed in Sec.2.1) and the peripherals (listed in Sec 2.2) were installed as shown on Sec.3.2 to meet FCC requirement and operating in a manner that tends to maximize its emission level in a normal application.

3.5 Operating Condition of EUT

- 3.5.1 Setup the EUT and peripherals as shown in Sec. 3.2.
- 3.5.2 Turn on the power of all equipments and the EUT.
- 3.5.3 Set the contrast & brightness of EUT to maximum.
- 3.5.4 PC system ran the self-test program “EMC Test” by windows XP and sent “H” characters to EUT through graphic card, the EUT’s screen displayed and filled with “H” pattern by its resolution (Via D-Sub & DVI Input).
- 3.5.5 Repeat above procedure from 3.5.3 to 3.5.4 for difference test mode.
- 3.5.6 The other peripherals devices were driven and operated during the test.
- 3.5.7 The test modes are as follows:

Test Mode
D-Sub 640*480@60Hz
D-Sub 1280*1024@75Hz
D-Sub 1680*1050@60Hz
DVI 640*480@60Hz
DVI 1280*1024@75Hz
DVI 1680*1050@60Hz

3.6 Test Procedures

The EUT and peripherals were connected to the power mains through an Artificial Mains Network (AMN). This provided a 50 ohm coupling impedance for the measuring equipment.

Both sides of AC line (Line & Neutral) were checked for maximum conducted interference. In order to find the maximum emission, the relative positions of equipment and all of the interface cables were changed or manipulated according to ANSI C63.4:2003 during conducted emission test.

The bandwidth of R&S Test Receiver ESCI was set at 9 kHz.

The frequency range from 150 kHz to 30 MHz was checked.

The test modes were done on conducted disturbance test and all the test results are listed in Sec. 3.7.

3.7 Test Results

< **PASS** >

The frequency and amplitude of the highest conducted emission relative to the limit is reported. All emissions not reported below are too low against the prescribed limits.

Test Mode	Page
D-Sub 640*480@60Hz	P12
D-Sub 1280*1024@75Hz	P13
D-Sub 1680*1050@60Hz	P14
DVI 640*480@60Hz	P15
DVI 1280*1024@75Hz	P16
DVI 1680*1050@60Hz	P17

NOTE 1 – The **bold test mode** listed above means the worst test mode.

NOTE 2 – Factor = Cable Loss + AMN Factor.

NOTE 3 – Emission Level = Meter Reading + Factor.

NOTE 4 – “QP” means “Quasi-Peak” values, “AV” means “Average” values.

NOTE 5 – The worst case is for DVI 1280*1024@75Hz test mode. The worst emission is detected at 23.140 MHz (Quasi-Peak Value) with corrected signal level of 46.20 dB (μV) (limit is 60.00 dB (μV)), when the Line of the EUT is connected to AMN.

EUT : LCD Monitor Temperature : 22°C
 Model No. : E2210PW Humidity : 48%RH
 Serial No. : 009NDBP56557 Date of Test : Sep 19, 2010
 Test Mode : D-Sub 640*480@60Hz

Test Line	Frequency (MHz)	Meter Reading dB(μV)	Factor (dB)	Emission Level dB(μV)	Limits dB(μV)	Margin (dB)	Remark
Line	0.153	41.78	0.37	42.15	65.82	23.67	QP
	0.190	40.97	0.38	41.35	64.02	22.67	
	0.310	39.27	0.45	39.72	59.97	20.25	
	2.962	33.42	0.70	34.12	56.00	21.88	
	9.204	38.81	1.02	39.83	60.00	20.17	
	22.896	41.27	1.73	43.00	60.00	17.00	
	0.153	31.27	0.37	31.64	55.82	24.18	AV
	0.190	23.64	0.38	24.02	54.02	30.00	
	0.310	21.45	0.45	21.90	49.97	28.07	
	2.962	21.53	0.70	22.23	46.00	23.77	
	9.204	28.15	1.02	29.17	50.00	20.83	
	22.896	31.24	1.73	32.97	50.00	17.03	
Neutral	0.150	41.64	0.32	41.96	66.00	24.04	QP
	0.310	37.29	0.39	37.68	59.97	22.29	
	0.923	31.23	0.51	31.74	56.00	24.26	
	2.334	32.48	0.61	33.09	56.00	22.91	
	6.285	38.62	0.82	39.44	60.00	20.56	
	22.535	40.86	1.83	42.69	60.00	17.31	
	0.150	31.26	0.32	31.58	56.00	24.42	AV
	0.310	27.51	0.39	27.90	49.97	22.07	
	0.923	21.26	0.51	21.77	46.00	24.23	
	2.334	21.64	0.61	22.25	46.00	23.75	
	6.285	25.64	0.82	26.46	50.00	23.54	
	22.535	21.01	1.83	22.84	50.00	27.16	

TEST ENGINEER: WENCY YANG

EUT : LCD Monitor Temperature : 22°C

Model No. : E2210PW Humidity : 48%RH

Serial No. : 009NDBP56557 Date of Test : Sep 19, 2010

Test Mode : D-Sub 1280*1024@75Hz

Test Line	Frequency (MHz)	Meter Reading dB(μV)	Factor (dB)	Emission Level dB(μV)	Limits dB(μV)	Margin (dB)	Remark
Line	0.153	41.14	0.37	41.51	65.82	24.31	QP
	0.184	40.19	0.38	40.57	64.28	23.71	
	0.310	39.35	0.45	39.80	59.97	20.17	
	2.839	35.54	0.69	36.23	56.00	19.77	
	8.916	36.29	1.01	37.30	60.00	22.70	
	23.387	40.68	1.74	42.42	60.00	17.58	
	0.153	31.26	0.37	31.63	55.82	24.19	AV
	0.184	31.25	0.38	31.63	54.28	22.65	
	0.310	28.54	0.45	28.99	49.97	20.98	
	2.839	25.64	0.69	26.33	46.00	19.67	
8.916	26.54	1.01	27.55	50.00	22.45		
23.387	21.58	1.74	23.32	50.00	26.68		
Neutral	0.156	40.07	0.32	40.39	65.65	25.26	QP
	0.183	40.61	0.31	40.92	64.33	23.41	
	0.310	35.78	0.39	36.17	59.97	23.80	
	2.581	31.82	0.63	32.45	56.00	23.55	
	6.285	37.48	0.82	38.30	60.00	21.70	
	23.636	39.76	1.85	41.61	60.00	18.39	
	0.156	21.35	0.32	21.67	55.65	33.98	AV
	0.183	21.65	0.31	21.96	54.33	32.37	
	0.310	25.64	0.39	26.03	49.97	23.94	
	2.581	21.64	0.63	22.27	46.00	23.73	
	6.285	24.21	0.82	25.03	50.00	24.97	
	23.636	21.46	1.85	23.31	50.00	26.69	

TEST ENGINEER: WENCY YANG

EUT : LCD Monitor Temperature : 22°C
 Model No. : E2210PW Humidity : 48%RH
 Serial No. : 009NDBP56557 Date of Test : Sep 19, 2010
 Test Mode : D-Sub 1680*1050@60Hz

Test Line	Frequency (MHz)	Meter Reading dB(μV)	Factor (dB)	Emission Level dB(μV)	Limits dB(μV)	Margin (dB)	Remark
Line	0.153	40.30	0.37	40.67	65.82	25.15	QP
	0.190	40.15	0.38	40.53	64.02	23.49	
	0.310	38.20	0.45	38.65	59.97	21.32	
	6.285	39.59	0.86	40.45	60.00	19.55	
	9.107	39.55	1.02	40.57	60.00	19.43	
	22.896	42.43	1.73	44.16	60.00	15.84	
	0.153	21.26	0.37	21.63	55.82	34.19	AV
	0.190	21.45	0.38	21.83	54.02	32.19	
	0.310	21.45	0.45	21.90	49.97	28.07	
	6.285	21.54	0.86	22.40	50.00	27.60	
	9.107	21.45	1.02	22.47	50.00	27.53	
	22.896	23.45	1.73	25.18	50.00	24.82	
Neutral	0.150	41.22	0.32	41.54	66.00	24.46	QP
	0.186	40.41	0.30	40.71	64.20	23.49	
	0.310	38.33	0.39	38.72	59.97	21.25	
	2.285	32.30	0.60	32.90	56.00	23.10	
	6.285	37.71	0.82	38.53	60.00	21.47	
	23.636	40.19	1.85	42.04	60.00	17.96	
	0.150	31.25	0.32	31.57	56.00	24.43	AV
	0.186	30.26	0.30	30.56	54.20	23.64	
	0.310	28.45	0.39	28.84	49.97	21.13	
	2.285	21.36	0.60	21.96	46.00	24.04	
	6.285	21.45	0.82	22.27	50.00	27.73	
	23.636	21.53	1.85	23.38	50.00	26.62	

TEST ENGINEER: WENCY YANG

EUT : LCD Monitor Temperature : 22°C

Model No. : E2210PW Humidity : 48%RH

Serial No. : 009NDBP56557 Date of Test : Sep 19, 2010

Test Mode : DVI 640*480@60Hz

Test Line	Frequency (MHz)	Meter Reading dB(μV)	Factor (dB)	Emission Level dB(μV)	Limits dB(μV)	Margin (dB)	Remark
Line	0.153	41.95	0.37	42.32	65.82	23.50	QP
	0.194	39.68	0.38	40.06	63.84	23.78	
	0.310	39.30	0.45	39.75	59.97	20.22	
	2.839	35.07	0.69	35.76	56.00	20.24	
	8.916	38.54	1.01	39.55	60.00	20.45	
	21.373	43.35	1.67	45.02	60.00	14.98	
	0.153	31.26	0.37	31.63	55.82	24.19	AV
	0.194	26.45	0.38	26.83	53.84	27.01	
	0.310	28.54	0.45	28.99	49.97	20.98	
	2.839	25.64	0.69	26.33	46.00	19.67	
	8.916	21.65	1.01	22.66	50.00	27.34	
	21.373	23.64	1.67	25.31	50.00	24.69	
Neutral	0.150	41.27	0.32	41.59	66.00	24.41	QP
	0.184	40.28	0.31	40.59	64.28	23.69	
	0.310	36.07	0.39	36.46	59.97	23.51	
	2.474	32.04	0.62	32.66	56.00	23.34	
	6.285	35.11	0.82	35.93	60.00	24.07	
	21.373	40.54	1.79	42.33	60.00	17.67	
	0.150	31.29	0.32	31.61	56.00	24.39	AV
	0.184	21.45	0.31	21.76	54.28	32.52	
	0.310	26.51	0.39	26.90	49.97	23.07	
	2.474	21.35	0.62	21.97	46.00	24.03	
	6.285	21.54	0.82	22.36	50.00	27.64	
	21.373	23.22	1.79	25.01	50.00	24.99	

TEST ENGINEER: WENCY YANG

EUT : LCD Monitor Temperature : 22°C
 Model No. : E2210PW Humidity : 48%RH
 Serial No. : 009NDBP56557 Date of Test : Sep 19, 2010
 Test Mode : DVI 1280*1024@75Hz

Test Line	Frequency (MHz)	Meter Reading dB(μV)	Factor (dB)	Emission Level dB(μV)	Limits dB(μV)	Margin (dB)	Remark
Line	0.152	40.50	0.37	40.87	65.91	25.04	QP
	0.310	39.31	0.45	39.76	59.97	20.21	
	2.794	35.61	0.68	36.29	56.00	19.71	
	6.285	38.44	0.86	39.30	60.00	20.70	
	8.916	39.47	1.01	40.48	60.00	19.52	
	23.140	44.47	1.73	46.20	60.00	13.80	
	0.152	30.24	0.37	30.61	55.91	25.30	AV
	0.310	21.30	0.45	21.75	49.97	28.22	
	2.794	25.30	0.68	25.98	46.00	20.02	
	6.285	21.02	0.86	21.88	50.00	28.12	
	8.916	21.36	1.01	22.37	50.00	27.63	
23.140	23.16	1.73	24.89	50.00	25.11		
Neutral	0.150	40.31	0.32	40.63	66.00	25.37	QP
	0.190	40.10	0.31	40.41	64.02	23.61	
	0.310	37.45	0.39	37.84	59.97	22.13	
	2.396	32.92	0.62	33.54	56.00	22.46	
	6.285	36.24	0.82	37.06	60.00	22.94	
	23.140	41.57	1.83	43.40	60.00	16.60	
	0.150	30.31	0.32	30.63	56.00	25.37	AV
	0.190	20.35	0.31	20.66	54.02	33.36	
	0.310	20.30	0.39	20.69	49.97	29.28	
	2.396	21.54	0.62	22.16	46.00	23.84	
	6.285	20.35	0.82	21.17	50.00	28.83	
23.140	31.25	1.83	33.08	50.00	16.92		

TEST ENGINEER: WENCY YANG

EUT : LCD Monitor Temperature : 22°C
 Model No. : E2210PW Humidity : 48%RH
 Serial No. : 009NDBP56557 Date of Test : Sep 19, 2010
 Test Mode : DVI 1680*1050@60Hz

Test Line	Frequency (MHz)	Meter Reading dB(μV)	Factor (dB)	Emission Level dB(μV)	Limits dB(μV)	Margin (dB)	Remark
Line	0.150	41.34	0.37	41.71	66.00	24.29	QP
	0.197	39.98	0.38	40.36	63.76	23.40	
	0.310	39.28	0.45	39.73	59.97	20.24	
	2.839	35.94	0.69	36.63	56.00	19.37	
	8.916	38.68	1.01	39.69	60.00	20.31	
	22.896	43.20	1.73	44.93	60.00	15.07	
	0.150	31.25	0.37	31.62	56.00	24.38	AV
	0.197	21.36	0.38	21.74	53.76	32.02	
	0.310	23.65	0.45	24.10	49.97	25.87	
	2.839	25.64	0.69	26.33	46.00	19.67	
	8.916	25.64	1.01	26.65	50.00	23.35	
	22.896	31.26	1.73	32.99	50.00	17.01	
Neutral	0.153	39.30	0.32	39.62	65.82	26.20	QP
	0.184	38.25	0.31	38.56	64.28	25.72	
	0.310	36.93	0.39	37.32	59.97	22.65	
	2.474	32.34	0.62	32.96	56.00	23.04	
	6.285	36.47	0.82	37.29	60.00	22.71	
	22.896	40.68	1.83	42.51	60.00	17.49	
	0.153	21.35	0.32	21.67	55.82	34.15	AV
	0.184	20.36	0.31	20.67	54.28	33.61	
	0.310	23.64	0.39	24.03	49.97	25.94	
	2.474	23.64	0.62	24.26	46.00	21.74	
	6.285	23.65	0.82	24.47	50.00	25.53	
	22.896	20.36	1.83	22.19	50.00	27.81	

TEST ENGINEER: WENCY YANG

4 RADIATED EMISSION TEST

4.1 Test Equipment

The following test equipments are used during the radiated emission test in a semi-anechoic chamber:

Item	Type	Manufacturer	Model No.	Serial No.	Last Cal.	Next Cal.
1.	Test Receiver	R&S	ESVS10	844594/001	Mar 07, 2010	Mar 07, 2011
2.	Preamplifier	Agilent	8447D	2944A10548	Sep 19, 2010	Mar 19, 2011
3.	Preamplifier	HP	8449B	3008A00864	Apr 29, 2010	Apr 29, 2011
4.	Bi-log Antenna	TESEQ	CBL6112D	23192	Dec 01, 2009	Dec 01, 2010
5.	Spectrum	Agilent	E7405A	MY45106600	May 19, 2010	May 19, 2011
6.	Software	Audix	E3	SET00200 9912M295-2	--	--

4.2 Block Diagram of Test Setup

4.2.1 EUT and Peripherals

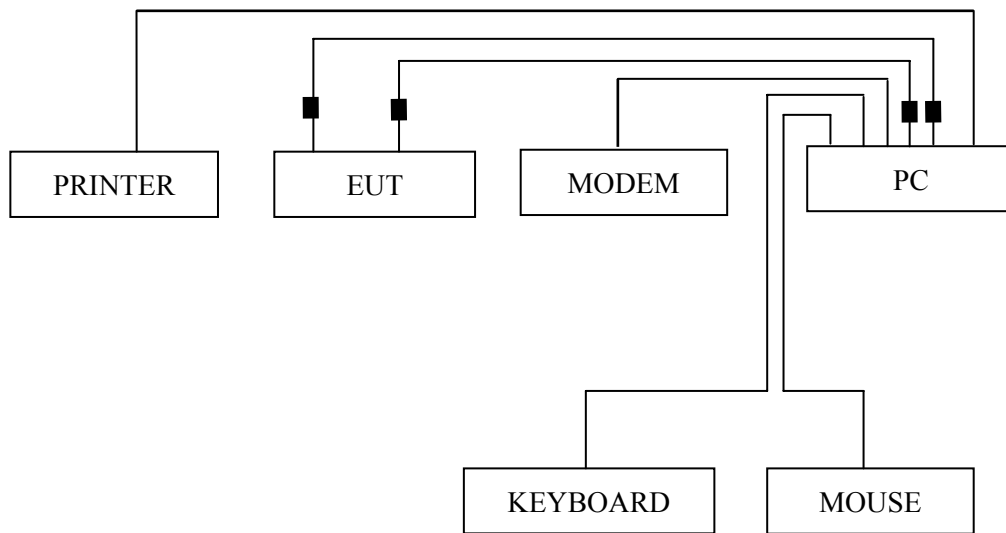

■: Ferrite core

4.2.2 Radiated emission test setup

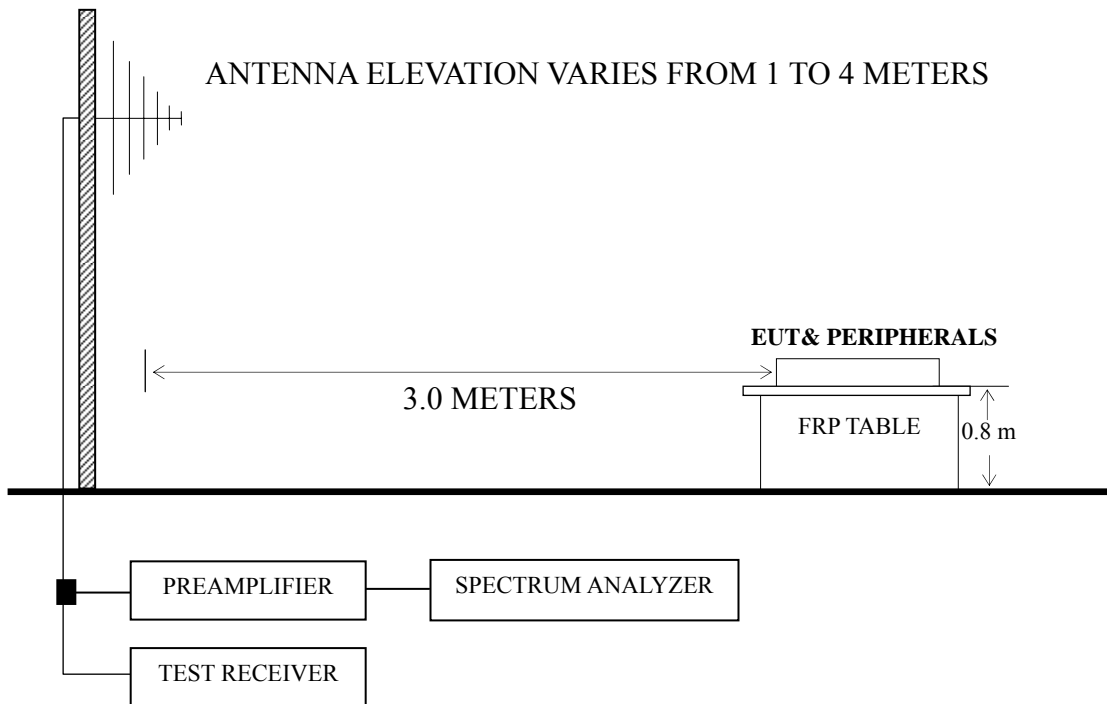

■ : 50 ohm Coaxial Switch

4.3 Radiated Emission Limit [FCC Part 15 Subpart B 15.109(a)]

Frequency (MHz)	Distance (m)	Field strength limits	
		($\mu\text{V/m}$)	dB ($\mu\text{V/m}$)
30 ~ 88	3	100	40.0
88 ~ 216	3	150	43.5
216 ~ 960	3	200	46.0
Above 960	3	500	54.0

NOTE 1 - Emission Level dB ($\mu\text{V/m}$) = 20 log Emission Level ($\mu\text{V/m}$)
 NOTE 2 - The tighter limit applies at the band edges.
 NOTE 3 - Distance refers to the distance in meters between the measuring instrument antenna and the closed point of any part of the device or system.
 NOTE 4 - The limits shown are based on Quasi-peak value detector below or equal to 1GHz and Average value detector above 1GHz.
 NOTE 5 - Above 1 GHz, the limit on peak emission is 20 dB above the maximum permitted average emission limit applicable to the EUT.

4.4 Test Configuration

The configuration of the EUT and peripherals are same as those used in conducted emission test.

Please refer to Sec.3.4.

4.5 Operating Condition of EUT

Same as conducted emission test which is listed in Sec.3.5, except for the test setup replaced by Sec.4.2.

4.6 Test Procedures

The EUT and peripherals were placed on a FRP turntable that is 0.8 meter above ground. The FRP turntable rotated 360 degrees to determine the position of the maximum emission level. The EUT was set 3 meters away from the receiving antenna, which was mounted on an antenna tower. Broadband antenna (Calibrated Bilog Antenna) was used as receiving antenna. The antenna moved up and down between 1 meter and 4 meters to find out the maximum emission level. Both horizontal and vertical polarizations of the antenna were set on measurement. In order to find the maximum emission, all of the interference cables were manipulated according to ANSI C63.4:2003 requirements during radiated emission test.

The I.F. bandwidth of Test Receiver R&S ESVS10 was set at 120 kHz below 1GHz and The Spectrum Agilent E7405A was set at 1MHz above 1GHz.

The frequency range from 30 MHz to 1000MHz was checked for all test modes.

The frequency range from 1 GHz to 2 GHz was checked for D-Sub/DVI 1280*1024@75Hz and 1680*1050@60Hz mode.

The test modes were done on radiated disturbance test and all the test results are listed in Sec.4.7.

4.7 Test Results

<PASS>

The frequency and amplitude of the highest radiated emission relative the limit is reported. All the emissions not reported below are too low against the FCC limit.

Test Mode	Page
D-Sub 640*480@60Hz	P22
D-Sub 1280*1024@75Hz	P23 – P24
D-Sub 1680*1050@60Hz	P25 – P26
DVI 640*480@60Hz	P27
DVI 1280*1024@75Hz	P28 – P29
DVI 1680*1050@60Hz	P30 – P31
D-Sub 640*480@60Hz (Rotate 90 degree)	P32

NOTE 1 – **The bold test mode** listed above means the worst test mode.

NOTE 2 – Emission Level = Antenna Factor + Cable Loss + Meter Reading. (< 1GHz)

NOTE 3 – Emission Level = Antenna Factor + Cable Loss – Preamp Factor + Meter Reading. (> 1GHz)

NOTE 4 – All readings are Quasi-Peak values below or equal to 1GHz, Peak and Average values above 1GHz.

NOTE 5 – The emission levels that are 20dB below the official limit are not reported.

NOTE 6 – 0° was the table front facing the antenna. Degree is calculated from 0° clockwise facing the antenna.

NOTE 7 – The worst case is for D-Sub 640*480@60Hz test mode. The worst emission at horizontal polarization was detected at 198.780 MHz with corrected signal level of 38.02 dB (μV/m) (limit is 43.50dB (μV/m)), when the antenna was 1.05 m height and the turntable was at 41°. The worst emission at vertical polarization was detected at 32.910 MHz with corrected signal level of 36.61 dB (μV/m) (limit is 40.00 dB (μV/m)), when the antenna was 1.02 m height and the turntable was at 322°.

EUT : LCD Monitor Temperature : 22°C

Model No. : E2210PW Humidity : 60%RH

Serial No. : 009NDBP56557 Date of Test : Sep 20, 2010

Test Mode : D-Sub 640*480@60Hz

Polarization	Frequency (MHz)	Meter Reading dB (μV)	Antenna Factor (dB/m)	Cable Loss (dB)	Emission Level dB (μV/m)	Limits dB (μV/m)	Margin (dB)
Horizontal	36.790	9.10	15.80	0.69	25.59	40.00	14.41
	67.830	11.31	6.52	0.88	18.71	40.00	21.29
	148.340	18.01	11.41	1.23	30.65	43.50	12.85
	198.780	25.94	10.64	1.44	38.02	43.50	5.48
	293.840	18.87	13.79	1.74	34.40	46.00	11.60
	667.290	7.96	19.55	2.61	30.12	46.00	15.88
Vertical	32.910	18.00	17.95	0.66	36.61	40.00	3.39
	41.640	20.35	13.02	0.73	34.10	40.00	5.90
	79.470	18.85	7.72	0.94	27.51	40.00	12.49
	225.940	17.45	11.94	1.53	30.92	46.00	15.08
	436.430	13.35	17.03	2.14	32.52	46.00	13.48
	872.930	11.08	21.46	2.98	35.52	46.00	10.48

TEST ENGINEER: RAVEN JIN

EUT : LCD Monitor Temperature : 22°C

Model No. : E2210PW Humidity : 60%RH

Serial No. : 009NDBP56557 Date of Test : Sep 20, 2010

Test Mode : D-Sub 1280*1024@75Hz

Polarization	Frequency (MHz)	Meter Reading dB (µV)	Antenna Factor (dB/m)	Cable Loss (dB)	Preamp Factor (dB)	Emission Level dB (µV/m)	Limits dB (µV/m)	Margin (dB)	Remark
Horizontal	34.850	0.11	16.97	0.68	--	17.76	40.00	22.24	QP
	80.440	12.63	7.85	0.95	--	21.43	40.00	18.57	
	172.590	15.61	10.11	1.35	--	27.07	43.50	16.43	
	198.780	20.10	10.64	1.44	--	32.18	43.50	11.32	
	305.480	15.01	14.07	1.78		30.86	46.00	15.14	
	931.130	4.09	21.93	3.40	--	29.42	46.00	16.58	
	1129.000	45.47	23.30	4.50	37.15	36.12	74.00	37.88	PK
	1194.000	46.28	23.67	4.51	37.02	37.44	74.00	36.56	
	1342.000	44.98	24.82	4.53	36.68	37.65	74.00	36.35	
	1429.000	45.19	25.38	4.54	36.45	38.66	74.00	35.34	
	1572.000	45.13	26.26	4.56	36.15	39.80	74.00	34.20	
	1754.000	45.13	26.80	4.58	35.87	40.64	74.00	33.36	
	1129.000	36.47	23.30	4.50	37.15	27.12	54.00	26.88	AV
	1194.000	35.28	23.67	4.51	37.02	26.44	54.00	27.56	
	1342.000	33.98	24.82	4.53	36.68	26.65	54.00	27.35	
	1429.000	33.19	25.38	4.54	36.45	26.66	54.00	27.34	
	1572.000	34.13	26.26	4.56	36.15	28.80	54.00	25.20	
	1754.000	33.13	26.80	4.58	35.87	28.64	54.00	25.36	

TEST ENGINEER: RAVEN JIN

EUT : LCD Monitor Temperature : 22°C

Model No. : E2210PW Humidity : 60%RH

Serial No. : 009NDBP56557 Date of Test : Sep 20, 2010

Test Mode : D-Sub 1280*1024@75Hz

Polarization	Frequency (MHz)	Meter Reading dB (µV)	Antenna Factor (dB/m)	Cable Loss (dB)	Preamp Factor (dB)	Emission Level dB (µV/m)	Limits dB (µV/m)	Margin (dB)	Remark
Vertical	41.640	22.01	13.02	0.73	--	35.76	40.00	4.24	QP
	79.470	23.83	7.72	0.94	--	32.49	40.00	7.51	
	133.790	15.04	12.35	1.18	--	28.57	43.50	14.93	
	279.290	12.78	13.52	1.70	--	28.00	46.00	18.00	
	557.680	4.23	18.68	2.38		25.29	46.00	20.71	
	870.990	9.32	21.42	2.98	--	33.72	46.00	12.28	
	1109.000	46.58	23.18	4.50	37.19	37.07	74.00	36.93	PK
	1194.000	46.60	23.67	4.51	37.02	37.76	74.00	36.24	
	1392.000	45.44	25.16	4.54	36.55	38.59	74.00	35.41	
	1559.000	45.16	26.19	4.56	36.18	39.73	74.00	34.27	
	1764.000	45.28	26.81	4.58	35.86	40.81	74.00	33.19	
	1789.000	47.47	26.87	4.58	35.82	43.10	74.00	30.90	
	1109.000	38.58	23.18	4.50	37.19	29.07	54.00	24.93	AV
	1194.000	36.60	23.67	4.51	37.02	27.76	54.00	26.24	
	1392.000	35.44	25.16	4.54	36.55	28.59	54.00	25.41	
	1559.000	35.16	26.19	4.56	36.18	29.73	54.00	24.27	
	1764.000	35.28	26.81	4.58	35.86	30.81	54.00	23.19	
	1789.000	34.47	26.87	4.58	35.82	30.10	54.00	23.90	

TEST ENGINEER: RAVEN JIN

EUT : LCD Monitor Temperature : 22°C

Model No. : E2210PW Humidity : 60%RH

Serial No. : 009NDBP56557 Date of Test : Sep 20, 2010

Test Mode : D-Sub 1680*1050@60Hz

Polarization	Frequency (MHz)	Meter Reading dB (µV)	Antenna Factor (dB/m)	Cable Loss (dB)	Preamp Factor (dB)	Emission Level dB (µV/m)	Limits dB (µV/m)	Margin (dB)	Remark
Horizontal	33.880	0.78	17.44	0.67	--	18.89	40.00	21.11	QP
	94.990	9.95	10.45	1.02	--	21.42	43.50	22.08	
	167.740	12.98	10.27	1.32	--	24.57	43.50	18.93	
	198.780	23.15	10.64	1.44	--	35.23	43.50	8.27	
	293.840	18.50	13.79	1.74	--	34.03	46.00	11.97	
	332.640	9.87	14.82	1.87	--	26.56	46.00	19.44	
	1019.000	45.51	22.51	4.49	37.36	35.15	74.00	38.85	PK
	1137.000	44.29	23.36	4.51	37.14	35.02	74.00	38.98	
	1277.000	44.52	24.32	4.53	36.84	36.53	74.00	37.47	
	1502.000	44.71	25.84	4.55	36.28	38.82	74.00	35.18	
	1682.000	43.97	26.61	4.57	35.97	39.18	74.00	34.82	
	1909.000	44.49	27.55	4.69	35.69	41.04	74.00	32.96	
	1019.000	38.51	22.51	4.49	37.36	28.15	54.00	25.85	AV
	1137.000	36.29	23.36	4.51	37.14	27.02	54.00	26.98	
	1277.000	37.52	24.32	4.53	36.84	29.53	54.00	24.47	
	1502.000	32.71	25.84	4.55	36.28	26.82	54.00	27.18	
	1682.000	33.97	26.61	4.57	35.97	29.18	54.00	24.82	
	1909.000	33.49	27.55	4.69	35.69	30.04	54.00	23.96	

TEST ENGINEER: RAVEN JIN

EUT : LCD Monitor Temperature : 22°C
 Model No. : E2210PW Humidity : 60%RH
 Serial No. : 009NDBP56557 Date of Test : Sep 20, 2010
 Test Mode : D-Sub 1680*1050@60Hz

Polarization	Frequency (MHz)	Meter Reading dB (µV)	Antenna Factor (dB/m)	Cable Loss (dB)	Preamp Factor (dB)	Emission Level dB (µV/m)	Limits dB (µV/m)	Margin (dB)	Remark
Vertical	41.640	21.29	13.02	0.73	--	35.04	40.00	4.96	QP
	53.280	21.50	8.14	0.80	--	30.44	40.00	9.56	
	80.440	23.30	7.85	0.95	--	32.10	40.00	7.90	
	198.780	20.35	10.64	1.44	--	32.43	43.50	11.07	
	358.830	11.87	15.57	1.95	--	29.39	46.00	16.61	
	870.990	8.75	21.42	2.98	--	33.15	46.00	12.85	
	1059.000	50.02	22.82	4.50	37.29	40.05	74.00	33.95	PK
	1194.000	51.56	23.67	4.51	37.02	42.72	74.00	31.28	
	1312.000	47.46	24.62	4.53	36.76	39.85	74.00	34.15	
	1429.000	52.08	25.38	4.54	36.45	45.55	74.00	28.45	
	1499.000	48.46	25.80	4.55	36.30	42.51	74.00	31.49	
	1789.000	52.95	26.87	4.58	35.82	48.58	74.00	25.42	
	1059.000	40.02	22.82	4.50	37.29	30.05	54.00	23.95	AV
	1194.000	39.56	23.67	4.51	37.02	30.72	54.00	23.28	
	1312.000	37.46	24.62	4.53	36.76	29.85	54.00	24.15	
	1429.000	40.08	25.38	4.54	36.45	33.55	54.00	20.45	
	1499.000	36.46	25.80	4.55	36.30	30.51	54.00	23.49	
	1789.000	41.95	26.87	4.58	35.82	37.58	54.00	16.42	

TEST ENGINEER: RAVEN JIN

EUT : LCD Monitor Temperature : 22°C

Model No. : E2210PW Humidity : 60%RH

Serial No. : 009NDBP56557 Date of Test : Sep 20, 2010

Test Mode : DVI 640*480@60Hz

Polarization	Frequency (MHz)	Meter Reading dB (µV)	Antenna Factor (dB/m)	Cable Loss (dB)	Emission Level dB (µV/m)	Limits dB (µV/m)	Margin (dB)
Horizontal	32.910	3.24	17.95	0.66	21.85	40.00	18.15
	62.980	14.80	6.57	0.86	22.23	40.00	17.77
	111.480	12.14	12.43	1.10	25.67	43.50	17.83
	191.990	20.85	10.37	1.42	32.64	43.50	10.86
	543.130	6.36	18.49	2.35	27.20	46.00	18.80
	890.390	10.49	21.60	3.02	35.11	46.00	10.89
Vertical	36.790	11.20	15.80	0.69	27.69	40.00	12.31
	114.390	6.43	12.64	1.10	20.17	43.50	23.33
	138.640	13.35	12.17	1.21	26.73	43.50	16.77
	358.830	6.82	15.57	1.95	24.34	46.00	21.66
	596.480	5.74	19.17	2.44	27.35	46.00	18.65
	960.230	4.76	22.13	3.76	30.65	54.00	23.35

TEST ENGINEER: RAVEN JIN

EUT : LCD Monitor Temperature : 22°C

Model No. : E2210PW Humidity : 60%RH

Serial No. : 009NDBP56557 Date of Test : Sep 20, 2010

Test Mode : DVI 1280*1024@75Hz

Polarization	Frequency (MHz)	Meter Reading dB (µV)	Antenna Factor (dB/m)	Cable Loss (dB)	Preamplifier Factor (dB)	Emission Level dB (µV/m)	Limits dB (µV/m)	Margin (dB)	Remark
Horizontal	35.820	8.00	16.45	0.68	--	25.13	40.00	14.87	QP
	58.130	14.20	6.96	0.83	--	21.99	40.00	18.01	
	138.640	11.35	12.17	1.21	--	24.73	43.50	18.77	
	177.440	12.84	9.98	1.37	--	24.19	43.50	19.31	
	410.240	3.75	16.64	2.08	--	22.47	46.00	23.53	
	841.890	3.90	21.12	2.95	--	27.97	46.00	18.03	
	1137.000	44.97	23.36	4.51	37.14	35.70	74.00	38.30	PK
	1237.000	48.09	24.02	4.52	36.93	39.70	74.00	34.30	
	1497.000	46.39	25.80	4.55	36.30	40.44	74.00	33.56	
	1669.000	45.71	26.58	4.57	35.99	40.87	74.00	33.13	
	1789.000	46.71	26.87	4.58	35.82	42.34	74.00	31.66	
	1909.000	48.15	27.55	4.69	35.69	44.70	74.00	29.30	
	1137.000	35.97	23.36	4.51	37.14	26.70	54.00	27.30	AV
	1237.000	37.09	24.02	4.52	36.93	28.70	54.00	25.30	
	1497.000	34.39	25.80	4.55	36.30	28.44	54.00	25.56	
	1669.000	33.71	26.58	4.57	35.99	28.87	54.00	25.13	
	1789.000	34.71	26.87	4.58	35.82	30.34	54.00	23.66	
	1909.000	32.15	27.55	4.69	35.69	28.70	54.00	25.30	

TEST ENGINEER: RAVEN JIN

EUT : LCD Monitor Temperature : 22°C
 Model No. : E2210PW Humidity : 60%RH
 Serial No. : 009NDBP56557 Date of Test : Sep 01, 2010
 Test Mode : DVI 1280*1024@75Hz

Polarization	Frequency (MHz)	Meter Reading dB (µV)	Antenna Factor (dB/m)	Cable Loss (dB)	Preamp Factor (dB)	Emission Level dB (µV/m)	Limits dB (µV/m)	Margin (dB)	Remark
Vertical	36.790	12.49	15.80	0.69	--	28.98	40.00	11.02	QP
	61.040	11.18	6.59	0.85	--	18.62	40.00	21.38	
	138.640	15.20	12.17	1.21	--	28.58	43.50	14.92	
	240.490	9.78	12.56	1.58	--	23.92	46.00	22.08	
	615.880	3.77	19.29	2.48	--	25.54	46.00	20.46	
	974.780	4.69	22.24	4.01	--	30.94	54.00	23.06	
	1194.000	48.97	23.67	4.51	37.02	40.13	74.00	33.87	PK
	1312.000	47.60	24.62	4.53	36.76	39.99	74.00	34.01	
	1424.000	46.64	25.34	4.54	36.48	40.04	74.00	33.96	
	1524.000	45.54	25.96	4.55	36.24	39.81	74.00	34.19	
	1789.000	51.10	26.87	4.58	35.82	46.73	74.00	27.27	
	1999.000	45.71	28.10	4.81	35.60	43.02	74.00	30.98	
	1194.000	39.97	23.67	4.51	37.02	31.13	54.00	22.87	AV
	1312.000	36.60	24.62	4.53	36.76	28.99	54.00	25.01	
	1424.000	35.64	25.34	4.54	36.48	29.04	54.00	24.96	
	1524.000	35.54	25.96	4.55	36.24	29.81	54.00	24.19	
	1789.000	37.10	26.87	4.58	35.82	32.73	54.00	21.27	
	1999.000	34.71	28.10	4.81	35.60	32.02	54.00	21.98	

TEST ENGINEER: RAVEN JIN

EUT : LCD Monitor Temperature : 22°C

Model No. : E2210PW Humidity : 60%RH

Serial No. : 009NDBP56557 Date of Test : Sep 20, 2010

Test Mode : DVI 1680*1050@60Hz

Polarization	Frequency (MHz)	Meter Reading dB (µV)	Antenna Factor (dB/m)	Cable Loss (dB)	Preamplifier Factor (dB)	Emission Level dB (µV/m)	Limits dB (µV/m)	Margin (dB)	Remark
Horizontal	32.910	0.70	17.95	0.66	--	19.31	40.00	20.69	QP
	61.040	5.04	6.59	0.85	--	12.48	40.00	27.52	
	138.640	8.35	12.17	1.21	--	21.73	43.50	21.77	
	179.380	14.34	9.92	1.37	--	25.63	43.50	17.87	
	463.590	2.07	17.43	2.20	--	21.70	46.00	24.30	
	832.190	3.35	21.01	2.93	--	27.29	46.00	18.71	
	1064.000	45.23	22.85	4.50	37.28	35.30	74.00	38.70	PK
	1194.000	44.45	23.67	4.51	37.02	35.61	74.00	38.39	
	1359.000	43.96	24.94	4.54	36.64	36.80	74.00	37.20	
	1529.000	45.47	26.00	4.55	36.23	39.79	74.00	34.21	
	1677.000	43.57	26.59	4.57	35.97	38.76	74.00	35.24	
	1862.000	43.39	27.26	4.67	35.74	39.58	74.00	34.42	
	1064.000	35.23	22.85	4.50	37.28	25.30	54.00	28.70	AV
	1194.000	33.45	23.67	4.51	37.02	24.61	54.00	29.39	
	1359.000	32.96	24.94	4.54	36.64	25.80	54.00	28.20	
	1529.000	33.47	26.00	4.55	36.23	27.79	54.00	26.21	
	1677.000	32.57	26.59	4.57	35.97	27.76	54.00	26.24	
	1862.000	30.39	27.26	4.67	35.74	26.58	54.00	27.42	

TEST ENGINEER: RAVEN JIN

EUT : LCD Monitor Temperature : 22°C
 Model No. : E2210PW Humidity : 60%RH
 Serial No. : 009NDBP56557 Date of Test : Sep 20, 2010
 Test Mode : DVI 1680*1050@60Hz

Polarization	Frequency (MHz)	Meter Reading dB (µV)	Antenna Factor (dB/m)	Cable Loss (dB)	Preamp Factor (dB)	Emission Level dB (µV/m)	Limits dB (µV/m)	Margin (dB)	Remark
Vertical	41.640	13.37	13.02	0.73	--	27.12	40.00	12.88	QP
	59.100	10.98	6.80	0.83	--	18.61	40.00	21.39	
	140.580	13.05	12.05	1.21	--	26.31	43.50	17.19	
	358.830	6.02	15.57	1.95	--	23.54	46.00	22.46	
	725.490	3.83	19.97	2.75	--	26.55	46.00	19.45	
	989.330	4.36	22.32	4.25	--	30.93	54.00	23.07	
	1124.000	44.46	23.27	4.50	37.16	35.07	74.00	38.93	PK
	1194.000	46.30	23.67	4.51	37.02	37.46	74.00	36.54	
	1432.000	43.85	25.38	4.55	36.45	37.33	74.00	36.67	
	1499.000	45.16	25.80	4.55	36.30	39.21	74.00	34.79	
	1662.000	44.99	26.56	4.57	36.00	40.12	74.00	33.88	
	1914.000	43.35	27.60	4.72	35.69	39.98	74.00	34.02	
	1124.000	35.46	23.27	4.50	37.16	26.07	54.00	27.93	AV
	1194.000	37.30	23.67	4.51	37.02	28.46	54.00	25.54	
	1432.000	32.85	25.38	4.55	36.45	26.33	54.00	27.67	
	1499.000	33.16	25.80	4.55	36.30	27.21	54.00	26.79	
	1662.000	31.99	26.56	4.57	36.00	27.12	54.00	26.88	
	1914.000	32.35	27.60	4.72	35.69	28.98	54.00	25.02	

TEST ENGINEER: RAVEN JIN

EUT : LCD Monitor Temperature : 22°C

Model No. : E2210PW Humidity : 60%RH

Serial No. : 009NDBP56557 Date of Test : Sep 20, 2010

Test Mode : D-Sub 640*480@60Hz
 (Rotate 90 degree)

Polarization	Frequency (MHz)	Meter Reading dB (μV)	Antenna Factor (dB/m)	Cable Loss (dB)	Emission Level dB (μV/m)	Limits dB (μV/m)	Margin (dB)
Horizontal	38.850	3.22	16.97	0.68	20.87	40.00	19.13
	82.190	14.67	7.85	0.95	23.47	40.00	16.53
	170.600	12.23	10.11	1.35	23.69	43.50	19.81
	187.550	22.00	10.64	1.44	34.08	43.50	9.42
	355.120	8.76	14.07	1.78	24.61	46.00	21.39
	926.330	10.17	21.93	3.40	35.50	46.00	10.50
Vertical	42.370	19.05	13.02	0.73	32.80	40.00	7.20
	75.450	20.56	7.72	0.94	29.22	40.00	10.78
	140.550	17.00	12.35	1.18	30.53	43.50	12.97
	276.710	10.29	13.52	1.70	25.51	46.00	20.49
	560.160	3.34	18.68	2.38	24.40	46.00	21.60
	880.120	8.77	21.42	2.98	33.17	46.00	12.83

TEST ENGINEER: RAVEN JIN

5 DEVIATION TO TEST SPECIFICATIONS

None.

6 DEBUG DESCRIPTION

The following components are used during the countermeasure procedures:

Name	M/N	Specifications (mm)	Manufacturer	Location
Adhesive Tape	T-308	50*30	DAEHUNG SUBSIDIARY MATERIALS.	See Internal Photo Figure 14
Sponge	LG END 3940TKK043C	90*10*1	EXPAN Elactronics SuZhou co.,Ltd	See Internal Photo Figure 15

Note: We had required the applicant and manufacturer that all electrical and mechanical devices employed for spurious radiation suppression, including any modifications made during certification testing, must be incorporated in each unit marked

TEST ENGINEER:

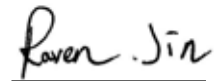

(RAVEN JIN)