

EVALUATION REPORT

MPE TEST REPORT

(Class II Permissive change)

Applicant: LG Electronics USA, Inc.
111 Sylvan Avenue North Building
Englewood Cliffs New Jersey United States 07632,
Attn: David Kim / Team leader

Date of Issue: Sep. 30, 2024
Order Number: GETEC-C1-24-686
Test Report Number: GETEC-E3-24-122
Test Site: GUMI UNIVERSITY EMC CENTER
CAB Designation Number: KR0033

FCC ID. : BEJE19MAE07
Applicant : LG Electronics USA, Inc.

Rule Part(s) : FCC Part 1
Test Method : FCC Part 1, Subpart I, section 1.1310 and KDB 680106 D01 v04
EUT Type : Household Refrigerator
Type of Authority : Certification
Model Name : SKSFD3604P
Trade Mark : LG

This equipment has been shown to be in compliance with the applicable technical standards as indicated in the measurement report and was tested in accordance with the measurement procedures specified in 47 CFR Part 1, Subpart I, section 1.1310 and KDB 680106 D01 v04

I attest to the accuracy of data. All measurements reported herein were performed by me or were made under my supervision and are correct to the vest of my knowledge and belief. I assume full responsibility for the completeness of these measurements and vouch for the qualifications of all persons taking them.

Tested by,



**Tak Dong Kim, Associate Engineer
GUMI UNIVERSITY EMC CENTER**

Reviewed by,



**Hyun Kim, Technical Manager
GUMI UNIVERSITY EMC CENTER**



Revision History

Test Report No.	Issue Date	Description
GETEC-E3-24-122	Sep. 30, 2024	First Approval Test Report

※ This test report is not related to the accredited test result by ISO/IEC 17025 and KOLAS





CONTENTS

1. GENERAL INFORMATION	4
2. INTRODUCTION	5
3. PRODUCT INFORMATION	6
3.1 DESCRIPTION OF EUT	6
3.2 DEFINITION OF MODELS	6
3.3 SUPPORT EQUIPMENT / CABLES USED	7
3.4 MODIFICATION ITEM(S)	7
4. DESCRIPTION OF TESTS	8
4.1 TEST CONDITION	8
5. TEST EQUIPMENT USED	8
6. TEST RESULT	9
6.1 TEST SETUP	9
6.2 MEASUREMENT PROCEDURE	9
6.3 EQUIPMENT APPROVAL CONSIDERATIONS	10
6.4 ENVIRONMENTAL EVALUATION AND EXPOSURE LIMIT	12
6.5 E AND H FIELD STRENGTH	13
6.5.1 FIELD STRENGTH MEASURE VALUE AT 10 CM FROM THE EDGES SURROUNDING THE EUT	13

APPENDIX A- TEST SET UP PHOTOGRAPHS



Scope: Measurement and determination of electromagnetic emissions (EME) of radio frequency devices including intentional and / or unintentional radiators for compliance with technical rules and regulations of the Federal Communications Commission.

1. General Information

Applicant: LG Electronics USA, Inc.

**Applicant Address: 111 Sylvan Avenue North Building
Englewood Cliffs New Jersey United States 07632**

Manufacturer: LG Electronics Inc.

**Manufacturer Address: 170, Sungsanpaechong-ro, Seongsan-gu, Changwon-si,
Gyeongsangnam-do, 51533, Korea**

Contact Person: David Kim / Team leader

Telephone Number: 1-201-266-2443

- **FCC ID.** BEJE19MAE07
- **EUT Type** Household Refrigerator
- **Model Name** SKSFD3604P
- **Rule Part(s)** FCC Part 1
- **Type of Authority** Certification
- **Test Procedure(s)** FCC Part 1, Subpart I, section 1.1310 and KDB 680106 D01 v04
- **Dates of Test** Sep. 20, 2024
- **Place of Test** **GUMI UNIVERSITY EMC CENTER**
(FCC Test Firm Registration Number: 269701)
(ISED Test Site Registration Number: 7920A)
37 Yaeun-ro, Gumi-si, Gyeongsangbuk-do, 39213, Republic of Korea.
- **Test Report Number** GETEC-E3-24-122
- **Dates of Issue** Sep. 30, 2024



2. Introduction

The measurement procedure described in American National Standard for Methods of Measurement of Radio-Nose Emissions From Low-Voltage Electrical and Electronic Equipment in the Range of 9 kHz to 40 GHz (ANSI C63.4-2017) was used in determining radiated and conducted emissions emanating from **Household Refrigerator (Model name: SKSFD3604P)**

These measurement tests were conducted at **GUMI UNIVERSITY EMC CENTER**.

The site address is 37 Yaeun-ro, Gumi-si, Gyeongsangbuk-do, 39213, Korea

This test site is one of the highest point of GUMI UNIVERSITY at about 200 kilometers away from Seoul city and 40 kilometers away from Daegu city. It is located in the valley surrounded by mountains in all directions where ambient radio signal conditions are quiet and a favorable area to measure the radio frequency interference on open field test site for the computing and ISM devices manufactures. The detailed description of the measurement facility was found to be in compliance with the requirements of §2.948 according to ANSI C63.4 (2017)

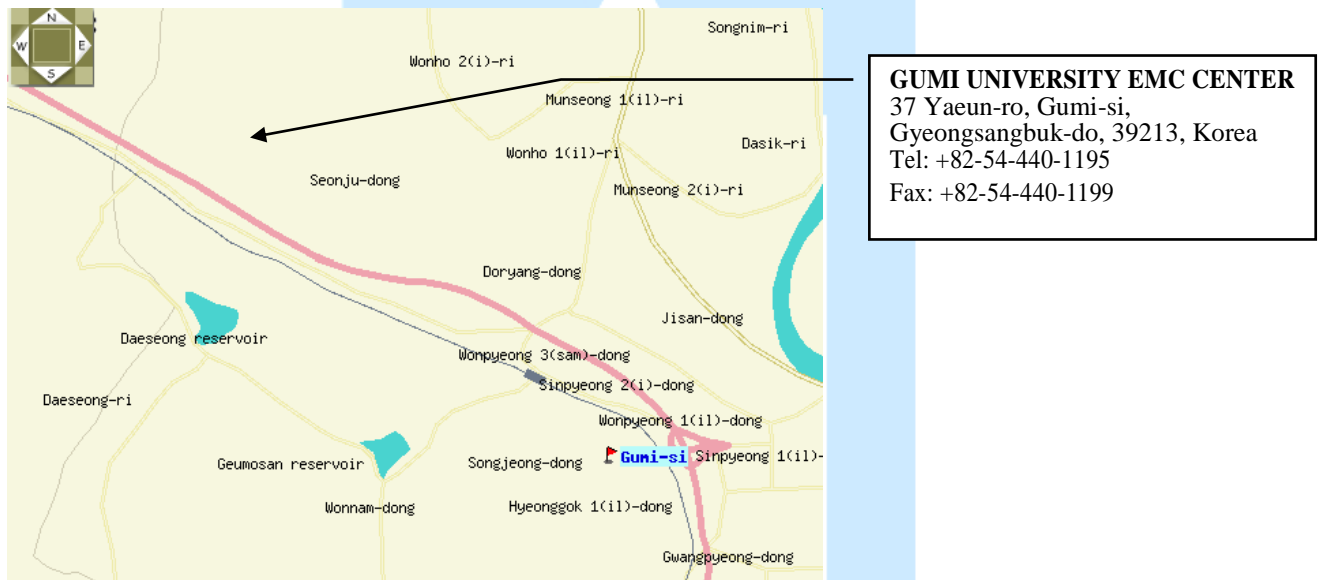

Fig 1. The map above shows the GUMI UNIVERSITY in vicinity area.



3. Product Information

3.1 Description of EUT

The Equipment under Test (EUT) is the **Household Refrigerator (Model Name: SKSFD3604P)**
FCC ID.: BEJE19MAE07

Type of Equipment	Household Refrigerator
Model Name	SKSFD3604P
Serial Number	Prototype
RF Frequency	330 kHz ~ 370 kHz
External connector	DC input 1 EA
Rated Voltage	Input : AC 115 V, 60 Hz (Wireless Power Transmitter input voltage: DC 12 V)
Output Electricity Power	Less than 3 W
Size(W x H x T)	35 ³ / ₄ (W) x23 ⁷ / ₈ (D) x83 ¹ / ₂ (H) inch (Wireless Power Transmitter module :50 (mm) x 35 (mm) x 1.0 (mm))

3.2 Definition of models

- None.



3.3 Support Equipment / Cables used

3.3.1 Used Support Equipment

Description	Manufacturer	Model Name	S/N & FCC ID.
None	-	-	S/N: - FCC ID.: -

3.3.2 System configuration

Description	Manufacturer	Model Name	S/N & FCC ID.
Home wireless power transfer device	LG Electronics Inc.	WRS-207	S/N: - FCC ID.: -
WLAN module	LG Electronics Inc.	LCW-003	S/N: -. FCC ID.: BEJ-LCW003

3.3.3 Used Cable(s)

Cable Name	Condition	Description
Power cable	Connected to the EUT and AC power	2.30 m Unshielded.

3.4 Modification Item(s)

-. None



4. Description of tests

4.1 Test Condition

The EUT was installed, arranged and operated in a manner that is most representative of equipment as typically used. The measurements were carried out while varying operating modes and cable positions within typically arrangement to determine maximum emission level.

The representative and worst test mode(s) were noted in the test report.

- Test Voltage / Frequency: AC 115V, 60 Hz
(Wireless Power Transfer Device were supplied DC 12 V from main system)
- Operating condition during the test(s) :
This device has been tested in the configurations of Power transfer mode with WLAN module operating.

Charging Current	Support Equipment	Comment
1 000 mA	Household Refrigerator Shelf RX module	

5. Test Equipment used

Model Name	Manufacturer	Description	Serial Number	Calibration Date
■ - ELT-400	Narda Safety Test Solutions GmbH	EMF Tester	N-8096	Feb. 24, 2024
■ - HI-6105	ETS LINDGREN	Electric field Probe	203871	Apr. 12, 2024

All test equipment used is calibrated on a regular basis.



6. Test Result

6.1 Test Setup

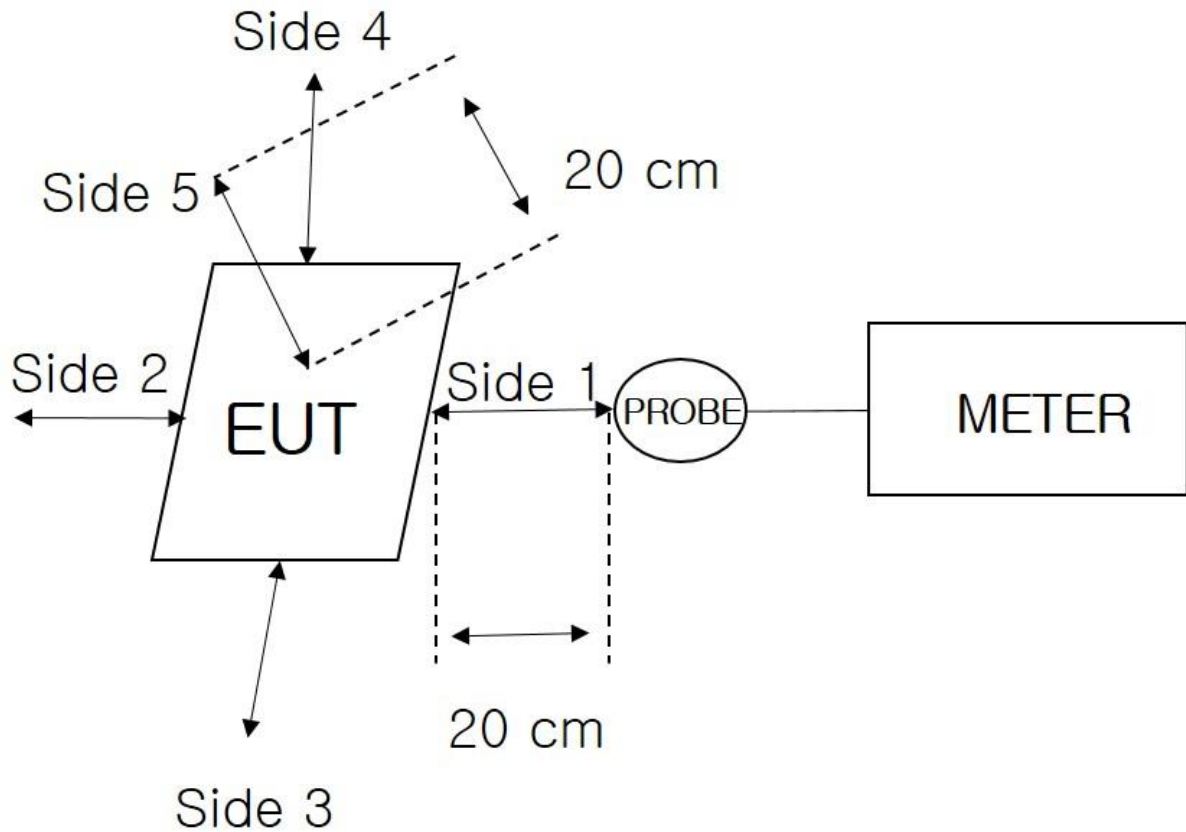

6.2 Measurement Procedure

These measurements shall be made along the major axis of the device, oriented along the direction of the estimated maximum field strength after a distance of 20 cm, and shall be made at three points per axis or until a 1/d (inverse distance from the emitter structure) field strength reduction is observed. Symmetry considerations may be used for test reduction purposes. The device shall be operated under the documented worst-case compliance scenario (i.e., the scenario that results in the maximum field component), and all radiating structures (e.g., coils or antennas) that are designed to transmit simultaneously shall be powered at their nominal maximum power. The EUT were measured according to the dictates of KDB 680106 D01v04



6.3 Equipment Approval Considerations.

The EUT does with item 5(b) of KDB 680106 D01v04r

a) Power transfer frequency is less than 1 MHz

- Power transfer(Main Carrier) frequency is fixed between 330 kHz ~ 370 kHz

b) The output power from each transmitting element (e.g., coil) is less than or equal to 15 watts.

- The maximum field strength of fundamental : 73.5 dB μ V/m at 3 m. The EIRP calculation is reference to KDB 789033

※ $EIRP[dBm] = E[dB\mu V/m] + 20\log(d[meters]) - 104.77$, $d = 3$ m

※ $73.5 \text{ dB}\mu V/m - 95.2 = -21.7 \text{ dBm EIRP}$

※ The output power from primary coil is 0.006 mW

c) A client device providing the maximum permitted load is placed in physical contact with the transmitter

(i.e., the surfaces of the transmitter and client device enclosures need to be in physical contact)

- The system is consists of single primary and secondary coils.

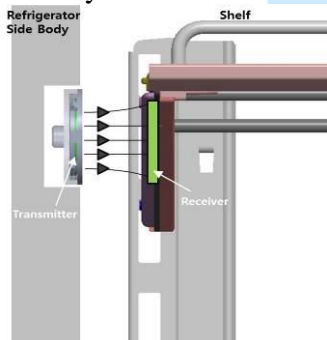

d) Mobile exposure conditions only (portable exposure conditions are not covered by this exclusion)
- Mobile exposure conditions only.

The E-field and H-field strengths, at and beyond 20 cm surrounding the device surface, are demonstrated to be less than 50% of the applicable MPE limit, per KDB 447498, Table 1. These measurements shall be taken along the principal axes of the device, with one axis oriented along the direction of the estimated maximum field strength, and for three points per axis or until a 1/d (inverse distance from the emitter structure) field strength decay is observed. Symmetry considerations may be used for test reduction purposes. The device shall be operated in documented worst-case compliance scenarios (i.e., the ones that lead to the maximum field components), and while all the radiating structures (e.g., coils or antennas) that by design can simultaneously transmit are energized at their nominal maximum power.- 0.161 A/m (maximum measure value) < 0.815 A/m (50% MPE limit)



- e) For systems with more than one radiating structure, the conditions specified in (5) must be met when the system is fully loaded (i.e., clients absorbing maximum power available), and with all the radiating structures operating at maximum power at the same time, as per design conditions. If the design allows one or more radiating structures to be powered at a higher level while other radiating structures are not powered, then those cases must be tested as well. For instance, a device may use three RF coils powered at 5 W, or one coil powered at 15 W: in this case, both scenarios shall be tested.

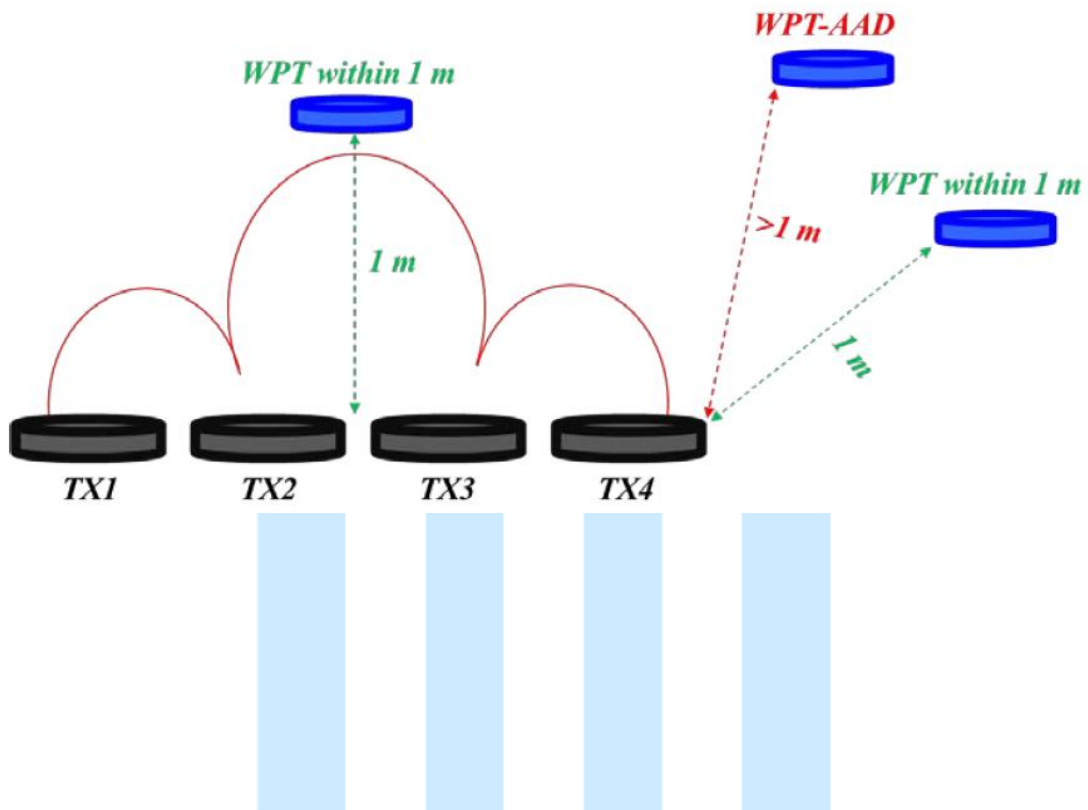



6.4 Environmental evaluation and exposure limit

*** according to FCC CFR 47 part 1, 1.1307(b), 1.1310**

§1.1310 : The criteria listed in the following table shall be used to evaluate the environment impact of human exposure to radio frequency (RF) radiation as specified in §1.1307(b), except in the case of portable devices which shall be evaluated according to the provisions of FCC part 2.1093 of this chapter

Table 1 – LIMITS FOR MAXIMUM PERMISSIBLE EXPOSURE (MPE)

Frequency Range (MHz)	Electric Field Strength(V/m)	Magnetic Field Strength(A/m)	Power Density (mW/cm ²)	Average Time (minutes)
(A) Limits for Occupational /Control Exposures				
0.3 – 3.0	614	1.63	*(100)	6
3.0 – 30	1842/f	4.89/f	*(900/f ²)	6
30 – 300	61.4	6.163	1.0	6
300 – 1 500			f/300	6
1 500 – 100 000			5	6
(B) Limits for General Population / Uncontrol Exposures				
0.3 – 1.34	614	1.63	*(100)	30
1.34 – 30	824/f	2.19	*(180/f ²)	30
30 – 300	27.5	0.073	0.2	30
300 – 1 500			f/1 500	30
1 500 – 100 000			1.0	30

F=frequency in MHz

* = Plane wave equivalent power density

Note 1 to Table 1: Occupational/controlled limits apply in situations in which persons are exposed as a consequence of their employment provided those persons are fully aware of the potential for exposure and can exercise control over their exposure. Limits for occupational/controlled exposure also apply in situations when an individual is transient through a location where occupational/controlled limits apply provided he or she is made aware of the potential for exposure.

Note 2 to Table 1: General population/uncontrolled exposures apply in situations in which the general public may be exposed, or in which persons that are exposed as a consequence of their employment may not be fully aware of the potential for exposure or can not exercise control over their exposure.



6.5 E and H field strength

Temperature : 20.9 °C
 Relative Humidity : 70.1 %
 Air pressure : 100.4 kPa
 Test mode : Continuous Power transfer mode with WLAN module operating

6.5.1 Field Strength measure value at 10 cm from the edges surrounding the EUT

Electric Field Strength

Test Position	Probe Measure Result(V/m)	Limit(V/m)	50 % Limit(V/m)
Side 1	3.33	614	307
Side 1(1door) ¹⁾	3.30	614	307
Side 2	1.09	614	307
Side 3	0.99	614	307
Side 4	1.36	614	307
Side 5	1.57	614	307

Magnetic Field Strength

Test Position	Probe Measure Result(A/m)	Limit(A/m)	50 % Limit(A/m)
Side 1	0.117	1.63	0.815
Side 1(1door) ¹⁾	0.102	1.63	0.815
Side 2	0.085	1.63	0.815
Side 3	0.087	1.63	0.815
Side 4	0.085	1.63	0.815
Side 5	0.161	1.63	0.815

Note: The bottom side was excluded from RF exposure testing as it is impractical to place the probe at this exposure distance due the EUT's design construct and use.

1) At the request of the customer, only one door was opened in side1 and tested additionally.

- The end -