

1. PURPOSE AND SCOPE

The purpose of this document is to establish a *product* specification for the antenna product that Galtronics is developing for the LGIC, for their wireless handset. This specification is preliminary. Any changes or additions to this specification can affect schedule and/or cost of the product and should be negotiated between Galtronics and the LGIC before being incorporated into the specification. Upon agreement of this specification Galtronics will make no changes without the written approval from the LGIC. Any changes requested by the LGIC will be given to Galtronics with sufficient time to evaluate the cost impact and react as required. The development of the product in Galtronics is conducted according to the Design Control Procedure SOP006E.

2. RELATED DOCUMENTS

SOP006E	Product Launch Procedure (Design Control)
EN006E	Reliability Guidelines
EIA-STD-556	Outer Shipping Container Bar Code Label Standard

3. ABBREVIATIONS AND DEFINITIONS

Ω	Ohm
°	Degree
°C	Celsius(degrees Centigrade)
cm	Centimeter
g	Grams
Hz	Hertz
MHz	Megahertz
m	Meter
mm	Millimeter
N	Newton
PCB	Printed Circuit Board
RH	Relative Humidity
W	Watt

Design specification: A preliminary target specification to guide design process
Product specification: A final specification for the qualified product

4. DESCRIPTION AND PART NUMBERS

4.1 DESCRIPTION

This antenna is a base helical retractable for use on a wireless handset. This antenna shall consist of two electromechanical pieces: A whip and a base. The whip shall extend and retract through the center of a fixed base lower helical, which is mounted to the handset via a screw thread interface. The whip element shall function in the full up position and the base helical shall function in the down position. The electrical, mechanical, and industrial design parameters required for this antenna are described below.

4.2 PART NUMBER

Galtronics Part Number	Frequency Band
02-4128-46-789(G)	824 - 894 MHz

5. ELECTRICAL SPECIFICATION

5.1 FREQUENCY BANDS

Band Name	Frequency Band
CDMA	824 - 894 MHz

5.2 IMPEDANCE

Nominal impedance (including matching circuit) : 50Ω

5.3 MATCHING REQUIREMENTS

In order to assure the best performance of the antenna, the matching will be evaluated in free space and in talk position for both extended and retracted position. The antenna will comply with the Electrical Specification requirements, as set out below, while mounted on the handset containing the PCB. The handset with PCB are to be supplied by the customer and should be representative of the latest design version of all parts. Any modifications in the handset or PCB can affect the performance of the antenna and should be discussed with Galtronics to determine the affect of such change on antenna performance and delivery requirements.

5.4 VSWR

5.4.1 Requirements in free space (Folder open)

Mode	Tx	Rx
Extended	2.0	2.0
Retracted	2.0	2.0

Transmit Band (Herein designated as Tx) -the frequencies of operation for the Band transmit function shall be 824 to 849 MHz.

Receive Band (Herein designated as Rx) -the frequencies of operation for the Band receive function shall be 869 to 894 MHz.

5.4.2 Test Method (Engineering)

The antenna is tested while mounted to the handset. The handset is set up with a 50Ω coaxial cable connected to the 50Ω point. Calibration is done at this 50Ω point. The other end of the 50Ω coaxial cable is connected to a network analyzer. The handset is positioned on a non-conductive table for free space measurements. VSWR is also evaluated in talk position on a phantom head for reference only.

5.4.3 Test Method (Production)

In mass production it is not practical to use the handset supplied by the customer. A production test fixture will be designed by Galtronics for use on processes requiring electrical testing. The results on the test fixture will be correlated to the results obtained on the customer handset. Testing in final inspection is done on a statistical basis.



5.5 GAIN

5.5.1 Gain Values

Mode	The average Gain in azimuth in free space - Folder open		The Gain in best direction in elevation in free space Folder open	
	Tx	Rx	Tx	Rx
Extended	0	0	0.5	0.5
Retracted	-1.5	-1.5	-1.0	-1.0

5.5.2 Test Method

The antenna is tested while mounted to the handset. The antenna is tested in free space in the anechoic chamber. Radiation patterns are measured at a minimum of 3 different frequencies.

5.6 POWER RATING

5.6.1 Requirements

Maximum value: 1 W

5.6.2 Test Method

The antenna is connected to the handset housing as described in 5.4.2. A power of 1 W is applied to the antenna for a period of 30 min. for extended and retracted position at room temperature (+20°±3°C). The antenna shall satisfy electrical requirements in 5.4.1 after the test and have no visible deterioration.

6. MECHANICAL SPECIFICATIONS

6.1 MECHANICAL CONFIGURATION

The appearance of the antenna is according to drawing 02-4128-46-789(G).

6.2 CONNECTOR TYPE

6.2.1 Type

The connector type is M5X0.5 Threaded Mount Boss (See DWG 22-151-03).

6.2.2 Materials

The connector base material is Free Cutting Brass (ISO CuZn39Pb3) with 7µ bright nickel plating (Cu/Ni7b ISO 1458-1988).

6.3 RETRACTION FORCES

6.3.1 Requirements for initial values

Position	Force range (N)
F1	0.5-5.0
F2	0.5-5.0
F3	0.5-5.0
F4	0.5-5.0

(See Figure 1 below for definition of F designations)

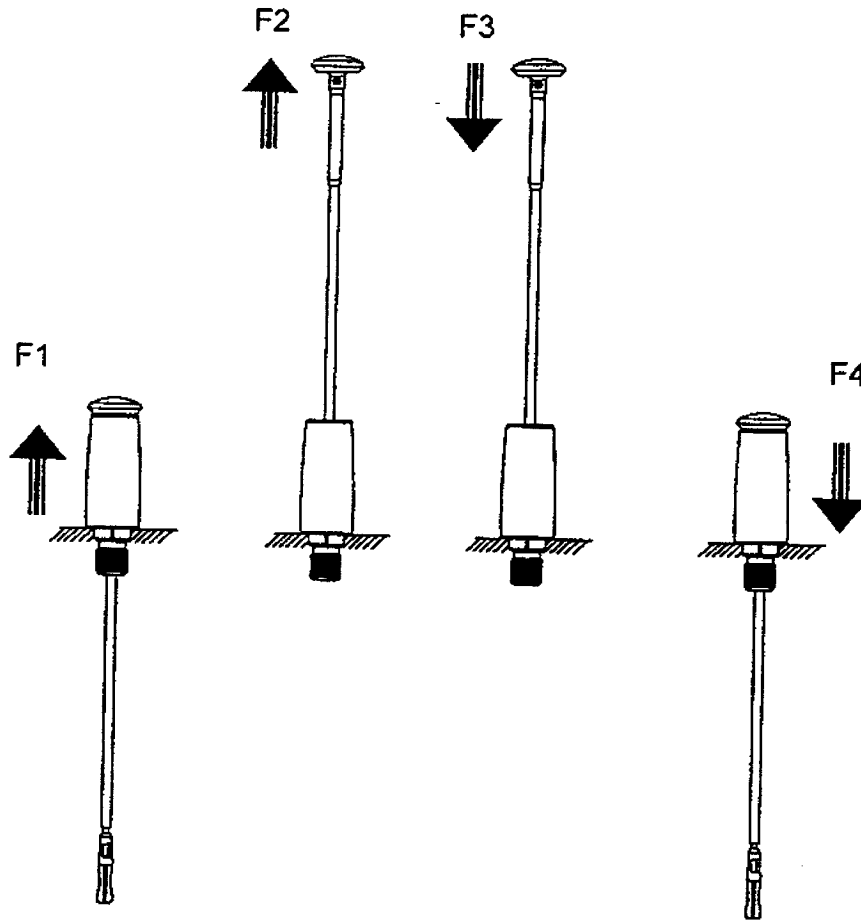

Figure 1. Force Designation for Retraction Forces

6.3.2 Test Method

The antenna is held fixed by the connector and gripped by the antenna cap. The antenna is moved from each position at a speed of 5 mm/s. The maximum force before the antenna is released is recorded. The mean force of 3 measurements for each position shall be within the specified values in 6.3.1.

6.4 WHIP TENSILE LOAD

6.4.1 Requirement

50 N axial pull force for 30 seconds.

6.4.2 Test Method

With the antenna connector mounted in an appropriate test fixture, apply axial tension load 50 N along the longitude axis to the antenna cap during 30 seconds Whip element fully extended. The sample is subjected to visual checking as well as to checking of electrical and mechanical working characteristics and must not have suffered from irreversible mechanical and electrical damage.



Figure 2. Method for Pull Strength Measurement

6.5 DROP

The antenna is attached to a dummy weighted radio (120 g). It should withstand 3 drops directed towards the antenna onto a steel plate 500x500mm with thickness of 20 mm. The drop height is 1.5 m. The drop tests will be done in retracted position with the angle to vertical 45°. The antenna shall satisfy the electrical specifications in 5.4.1 after the test. The antenna should function mechanically after the test. The antenna can be physically straightened at the end of the test. Temperature of the environment $+24^{\circ}\text{C} \pm 3^{\circ}\text{C}$.

6.6 HELIX TORQUE

6.6.1 Requirements

No electrical or mechanical deformation is admitted when the helical is turned with a torque of 30 Ncm.

6.6.2 Test Method

Torque test of the helical. The helical is fixed onto a test bench and the torque gauge chuck is applied to the top of the helical. The chuck of the gauge is then turned clockwise until the torque reaches 30 Ncm. The helical plastic must not rotate in relation to the fixture. No change of the electrical parameters from the specified range may be allowed. The test is shown in Figure 3.

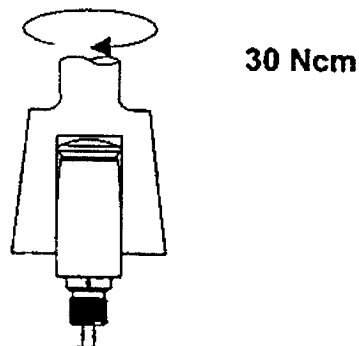

Figure 3. Torque test accomplishment



6.7 HELIX BENDING

With the antenna connector mounted in an appropriate test fixture, apply lateral load 40 N to the helix with bend of helix no more than 30°. Whip element inserted. The sample is subjected to visual checking as well as to checking of electrical and mechanical working characteristics and must not have suffered from irreversible mechanical and electrical damage.

6.8 HELIX TENSILE LOAD

With the antenna connector mounted in an appropriate test fixture, apply axial tension load 50 N along the longitude axis to the helix. Whip element inserted. The sample is subjected to visual checking as well as to checking of electrical and mechanical working characteristics and must not have suffered from irreversible mechanical and electrical damage.

6.9 TUBE ATTACHMENT

The tube shall withstand a 0.5N force (parallel to the antenna axis) without detachment from the connector.

6.10 ASSEMBLY/DISASSEMBLY CYCLES

The antenna shall withstand 500 cycles of assembly / disassembly to the radio with no damage. The test shall be conducted manually between the antenna and radio handset.

7. ENVIRONMENTAL SPECIFICATIONS

7.1 TEMPERATURE CYCLING

Place complete antenna in an environmental chamber at temperature T1=-40°C. Expose antenna to this temperature during 30 minutes. Then increase temperature to value of T2=80°C during 60 minutes and soak at this temperature during 30 minutes. Relative Humidity must be 50% RH. Repeat this cycle 10 times. After test is complete: there shall be no visual deterioration or damage. Electrical characteristics should be within the specified range.

7.2 SALT SPRAY

Place complete antenna in Salt Spray Cabinet at temperature +35°C with the salt fog of NaCl solution (5%); soak time - 96 hours. After test is complete: there shall be no visual degradation in esthetical and mechanical performance. Electrical characteristics should be within the specified range.

7.3 STATIC HUMIDITY

Place complete antenna in an environmental chamber at +20°C. Increase temperature with speed 1° per minute during 2 hours to +55° C with humidity increasing to 95% RH during 2 hours. Soak antenna with these parameters for 24 hours. After the finish initial ambient parameters should be achieved during 1 hour. After the test perform an inspection of the tested samples. After test is complete: there shall be no visual degradation in esthetical and mechanical performance. Electrical characteristics should be within the specified range.

7.4 RANDOM VIBRATION

The antenna shall withstand 6 G's RMS ($0.04g^2/Hz$) for 15 minutes in the vertical and horizontal axis. No appearance or function changes shall be found after the test.

7.5 OPERATING TEMPERATURE RANGE

The operational temperature range shall be: $-30^{\circ}C$ to $+80^{\circ}C$ at 50% RH.

7.6 AGING

The antenna shall withstand 3 years dark storage.

7.7 UV RESISTANCE

The antenna shall withstand UV Resistance according to IEC 68-2-5, Part 2, Test Sa, Procedure A (10 cycles, $40^{\circ}C$, no humidity, no operation).

8. RELIABILITY SPECIFICATIONS

8.1 CONNECTOR RELIABILITY

The antenna shall withstand 10,000 retraction cycles. The antenna should be rotated periodically during the test. After testing the retraction forces should not be less than 50 grams.

8.2 WHIP BENDING ENDURANCE

With the antenna mounted in an appropriate test fixture, cycle the whip left/right 90° to the vertical 400 times at a rate of 20-30 cycles/min.

Conditions: At $+25^{\circ}C$, Whip element extended.

The sample is subjected to visual checking as well as to checking of electrical and mechanical working characteristics and must not have suffered from irreversible mechanical and electrical damage.

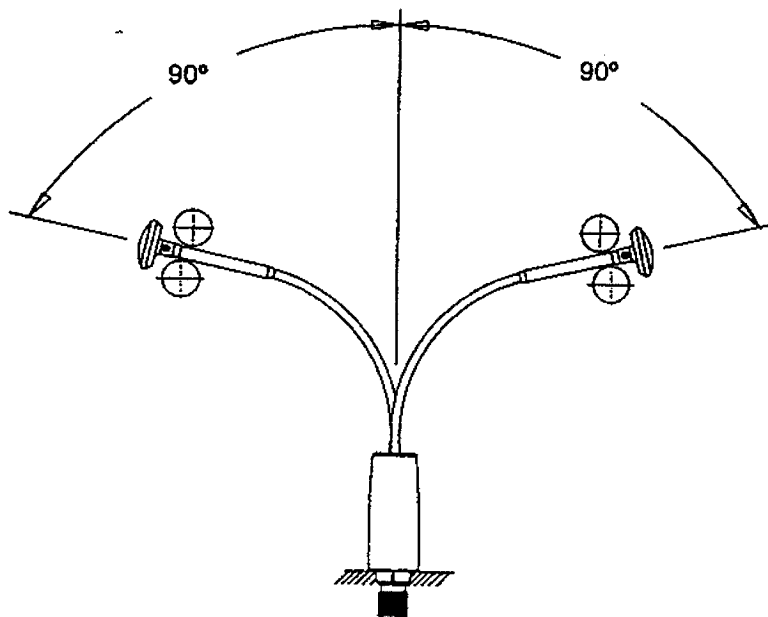

CONFIDENTIAL

Figure 4. Method for Whip Bending Endurance Testing

8.3 WHIP BEND TEST.

The antenna is assembled to the test equipment. A test fixture is attached to the top of the antenna's knob in extended position. The antenna is bent around a mandrel $\varnothing 40$ mm. The antenna is released and sprung back to vertical position. Test shall be performed at the ambient temperature and humidity.

Remaining deformation shall be < 0.5 mm for each 40 mm of wire length. No fracture shall be revealed after the test.

9. QUALIFICATION

The mechanical, environmental and reliability tests mentioned above are performed according to the flow chart shown in Figure 5 below. The entire testing procedure will be conducted according to EN006E. A summary report of the results of the tests will be sent to the customer. Galtronics will not start mass production until the customer will grant the product a qualified status.

10. PACKAGING

The antennas will be packed in compartmentalized vacuum formed trays. There are 40 antennas per tray. (See Appendix) Each tray will be labeled with the part number of antenna. The trays are packed in a corrugated fiberboard over box, 28 trays per box. The over box will be labeled for shipping according to the standards outlined in EIA-STD-556 (See Figure 7).

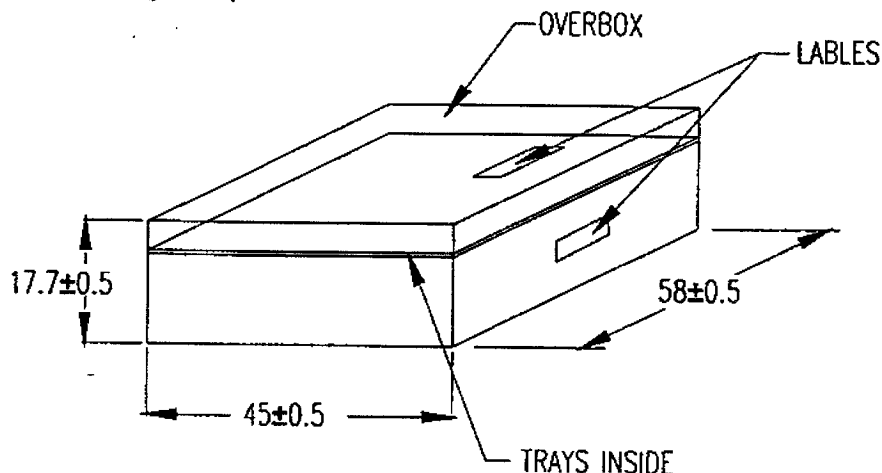

Figure 7. Packaging (dimensions of overbox in cm)

The labels should provide following information:

- Supplier's Address;
- Customer's Address;
- Package Count;
- Package Weight;

- Ship Date;
- Ship Number;
- Sales Order Number;
- Vendor's Part Number;
- Package Identification (Bar Code);
- Special (Bar Code);
- Total Quantity (Bar Code);
- Transaction Identification (Bar Code);
- Customer Product Identification (Bar Code).

CONFIDENTIAL



11. PRODUCTION SITE

The antennas will be manufactured by Galtronics Israel.
 Address: P.O.Box 1589, Tiberias, Israel
 Tel: 972-6-6739777
 Fax: 972-6-6732037

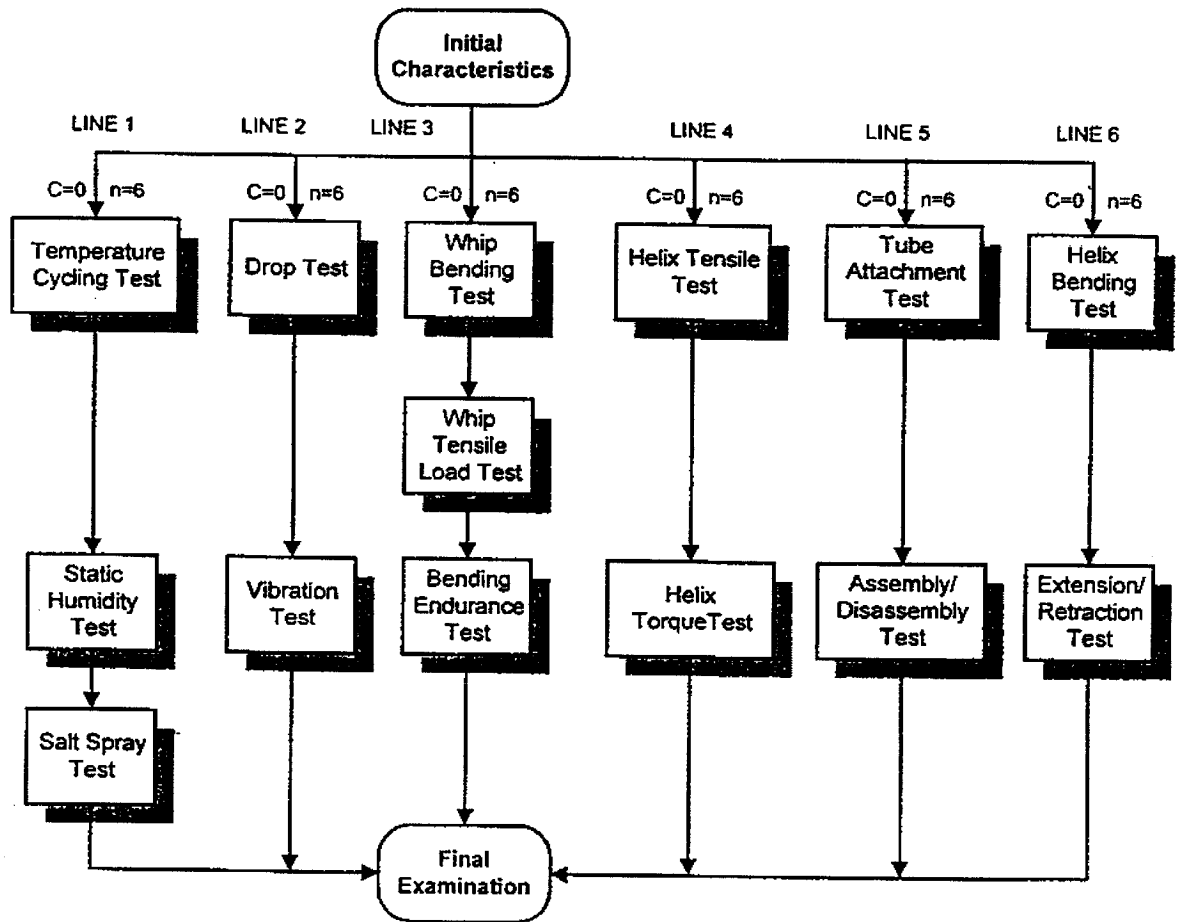
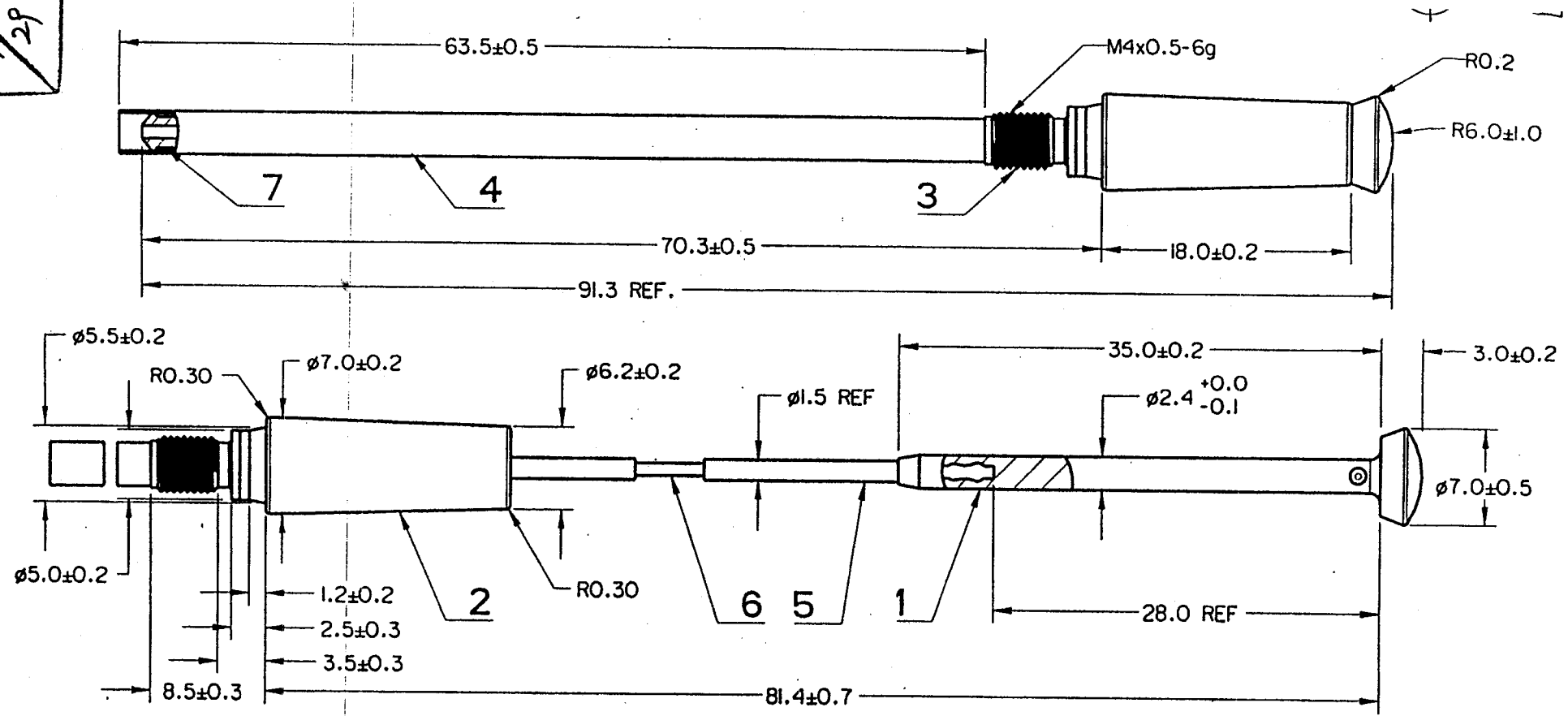

Figure 5. Qualification Flow Chart
 Allowed amount of failures after every test line c=0; Sample size n=6

29



7	Arcap APID		
6	Ni-Ti-Cr Super Elastic Alloy		
5	Plastic: Poliurethane-Shore 40D		
4	Plastic: PAI2	Color: Gray, Pantone 427C	Color: Gray, Pantone Cool Gray 7C
3	Free Cutting Brass ISO CuZn39Pb9 (MS 58A)	Cu/Cu strike/Ni7b ISO 1458-1988	Cu/Cu strike/Ni7b ISO 1458-1988
2	Plastic: Polyurethane -Shore 64D	Color: Gray, Pantone 427C	Color: Gray, Pantone Cool Gray 7C
1	Plastic: Zytel Compound 70% EIOI L-30%80IST	Color: Gray, Pantone 427C	Color: Gray, Pantone Cool Gray 7C
NO	MATERIAL	02-4128-46-789	02-4128-46-789G

7/7 gr. 2/05
[Signature]

CAD FILE: 02-4128-46-789		SEE COVER SHEET FOR PERTINENT INFORMATION			PAGE 2 OF 2		
 GALTRONICS THIS PRINT IS GALTRONICS CONFIDENTIAL	ENGINEER	R.G.	CHECKED	<i>[Signature]</i>	MOLDED NO NAME M4 STUD RETRACTABLE BH CDMA LGIC	DWG. NO.: A3 02-4128-46-789G	
	DRAWN	<i>[Signature]</i>	APPVD.	<i>[Signature]</i>			REV
	DATE	3-5-2000	DATE	3.5.00			S-3

CONFIDENTIAL