



PCTEST ENGINEERING LABORATORY, INC.

6660-B Dobbin Road, Columbia, MD 21045 USA
Tel. 410.290.6652 / Fax 410.290.6554
<http://www.pctestlab.com>



CERTIFICATE OF COMPLIANCE FCC Part 22 & 24 Certification

Applicant Name:
LG Electronics USA
1000 Sylvan Avenue
Englewood Cliffs, NJ 07632
United States

Date of Testing:
October 13-18, 2006
Test Site/Location:
PCTEST Lab, Columbia, MD, USA
Test Report Serial No.:
0610110885

FCC ID:	BEJCU400
APPLICANT:	LG ELECTRONICS USA

Application Type: Certification
FCC Classification: PCS Licensed Transmitter Held to Ear (PCE)
FCC Rule Part(s): §2; §22(H), §24(E)
EUT Type: Dual-Band Dual-Mode GSM/WCDMA Phone with Bluetooth
Model(s): CU400
Tx Frequency Range: 824.20 - 848.80MHz (Cell. GSM) / 1850.20 - 1909.80MHz (PCS GSM)
Rx Frequency Range: 869.20 - 893.80MHz (Cell. GSM) / 1930.20 - 1989.80MHz (PCS GSM)
Max. RF Output Power: 1.779 W ERP Cell. GSM (32.5 dBm) / 1.07 W ERP Cell. EDGE (30.293dBm)
1.863 W EIRP PCS GSM (32.7 dBm) / 1.104 W EIRP PCS EDGE (30.421dBm)

Max. SAR Measurement: 0.773 W/kg Cell. GSM Head SAR; 1.14 W/kg Cell. GSM Body SAR
0.355 W/kg PCS GSM Head SAR; 0.34 W/kg PCS GSM Body SAR

Emission Designator(s): 248KGXW (Cell. GSM) / 2KG7W (Cell. EDGE)
312KGXW (PCS GSM) / 241KG7W (PCS EDGE)

Test Device Serial No.: *identical prototype* [S/N: 440015202000000]
Class II Permissive Change: See change document.
Original Grant Date: August 10, 2006

This equipment has been shown to be capable of compliance with the applicable technical standards as indicated in the measurement report and was tested in accordance with the measurement procedures specified in §2.947.



I attest to the accuracy of data. All measurements reported herein were performed by me or were made under my supervision and are correct to the best of my knowledge and belief. I assume full responsibility for the completeness of these measurements and vouch for the qualifications of all persons taking them.

Grant Conditions: Power output listed is ERP for Part 22 and EIRP for Part 24. SAR compliance for body-worn operating configuration is based on a separation distance of 1.5 between the back of the unit and the body of the user. End-users must be informed of the body-worn operating requirements for satisfying RF exposure compliance. Belt clips or holsters may not contain metallic components.

PCTEST certifies that no party to this application has been denied the FCC benefits pursuant to Section 5301 of the Anti-Drug Abuse Act of 1988, 21 U.S.C. 862.



Randy Ortanez
President



FCC ID: BEJCU400		FCC Pt. 22/24 GSM MEASUREMENT REPORT		Reviewed by: Quality Manager
Test Report S/N: 0610110885	Test Dates: October 13-18, 2006	EUT Type: Dual-Band Dual-Mode GSM/WCDMA Phone with Bluetooth		Page 1 of 29

T A B L E O F C O N T E N T S

FCC PART 22 & 24 MEASUREMENT REPORT	3
1.0 INTRODUCTION	4
1.1 MEASUREMENT PROCEDURE	4
1.2 SCOPE	4
1.3 TESTING FACILITY	4
2.0 PRODUCT INFORMATION	5
2.1 EQUIPMENT DESCRIPTION	5
2.2 EMI SUPPRESSION DEVICE(S)/MODIFICATIONS	5
3.0 DESCRIPTION OF TESTS	6
3.1 OCCUPIED BANDWIDTH EMISSION LIMITS	6
3.2 CELLULAR - BASE FREQUENCY BLOCKS	6
3.3 CELLULAR - MOBILE FREQUENCY BLOCKS	6
3.4 PCS - BASE FREQUENCY BLOCKS	7
3.5 PCS - MOBILE FREQUENCY BLOCKS	7
3.6 SPURIOUS AND HARMONIC EMISSIONS AT ANTENNA TERMINAL	7
3.7 FREQUENCIES	8
3.8 RADIATED SPURIOUS AND HARMONIC EMISSIONS	8
3.9 FREQUENCY STABILITY / TEMPERATURE VARIATION	8
4.0 TEST EQUIPMENT CALIBRATION DATA	10
5.0 SAMPLE CALCULATIONS	11
6.0 TEST RESULTS	12
6.1 CONDUCTED OUTPUT POWER	13
6.2 EFFECTIVE RADIATED POWER OUTPUT DATA	14
6.3 EQUIVALENT ISOTROPIC RADIATED POWER OUTPUT DATA	15
6.4 CELLULAR GSM RADIATED MEASUREMENTS	16
6.5 PCS GSM RADIATED MEASUREMENTS	19
6.6 CELLULAR GSM FREQUENCY STABILITY MEASUREMENTS	22
6.7 PCS GSM FREQUENCY STABILITY MEASUREMENTS	24
7.0 CONCLUSION	26
EXHIBIT A - PLOT(S) OF EMISSIONS	27
EXHIBIT B – TEST SETUP PHOTOGRAPHS	28
EXHIBIT C – INTERNAL/EXTERNAL PHOTOGRAPHS	29

FCC ID: BEJCU400		FCC Pt. 22/24 GSM MEASUREMENT REPORT		Reviewed by: Quality Manager
Test Report S/N: 0610110885	Test Dates: October 13-18, 2006	EUT Type: Dual-Band Dual-Mode GSM/WCDMA Phone with Bluetooth		Page 2 of 29

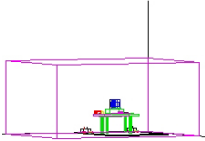

MEASUREMENT REPORT

FCC Part 22 & 24

A. §2.1033 General Information



APPLICANT: LG Electronics USA
APPLICANT ADDRESS: 1000 Sylvan Avenue
 Englewood Cliffs, NJ 07632
TEST SITE: PCTEST ENGINEERING LABORATORY, INC.
TEST SITE ADDRESS: 6660-B Dobbin Road, Columbia, MD 21045 USA
FCC RULE PART(S): §2; §22(H), §24(E)
MODEL NAME: CU400
FCC ID: BEJCU400
FCC CLASSIFICATION: PCS Licensed Transmitter Held to Ear (PCE)
EMISSION DESIGNATOR(S): 293KGXW (Cellular GSM) / 270KGXW / 242KG7W (EDGE)
MODE: GSM / EDGE
FREQUENCY TOLERANCE: ±0.00025 % (2.5 ppm)
Test Device Serial No.: 440015202000000 Production Pre-Production Engineering
DATE(S) OF TEST: October 13-18, 2006
TEST REPORT S/N: 0610110885

A.1 Test Facility / Accreditations

Measurements were performed at PCTEST Engineering Lab located in Columbia, MD 21045, U.S.A.

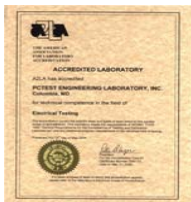
- PCTEST facility is an FCC registered (PCTEST Reg. No. 90864) test facility with the site description report on file and has met all the requirements specified in Section 2.948 of the FCC Rules and Industry Canada (IC-2451).
- PCTEST Lab is accredited to ISO 17025 by U.S. National Institute of Standards and Technology (NIST) under the National Voluntary Laboratory Accreditation Program (NVLAP Lab code: 100431-0) in EMC, FCC and Telecommunications.
- PCTEST Lab is accredited to ISO 17025-2005 by the American Association for Laboratory Accreditation (A2LA) in Specific Absorption Rate (SAR) testing, Hearing Aid Compatibility (HAC) testing, CTIA Test Plans, and wireless testing for FCC and Industry Canada Rules.
- PCTEST Lab is a recognized U.S. Conformity Assessment Body (CAB) in EMC and R&TTE (n.b. 0982) under the U.S.-EU Mutual Recognition Agreement (MRA).
- PCTEST TCB is a Telecommunication Certification Body (TCB) accredited to ISO/IEC Guide 65 by the American National Standards Institute (ANSI) in all scopes of FCC Rules and Industry Canada Standards (RSS).
- PCTEST facility is an IC registered (IC-2451) test laboratory with the site description on file at Industry Canada.
- PCTEST is a CTIA Authorized Test Laboratory (CATL) for AMPS, CDMA, and EvDO wireless devices and for Over-the-Air (OTA) Antenna Performance testing for AMPS, CDMA, GSM, GPRS, EGPRS, UMTS (W-CDMA), CDMA 1xEVDO, and CDMA 1xRTT.



FCC ID: BEJCU400	 FCC Pt. 22/24 GSM MEASUREMENT REPORT 		Reviewed by: Quality Manager
Test Report S/N: 0610110885	Test Dates: October 13-18, 2006	EUT Type: Dual-Band Dual-Mode GSM/WCDMA Phone with Bluetooth	Page 3 of 29

1.0 INTRODUCTION

1.1 Measurement Procedure

The radiated spurious measurements were made outdoors at a 3-meter test range (see Figure 1-1). The equipment under test is placed on a wooden turntable 3-meters from the receive antenna. The receive antenna height and turntable rotations were adjusted for the highest reading on the receive spectrum analyzer. A half-wave dipole was substituted in place of the EUT. This dipole antenna was driven by a signal generator and the level of the signal generator was adjusted to obtain the same receive spectrum analyzer reading. This level is recorded. For readings above 1GHz, the above procedure is repeated using horn antennas and the difference between the gain of the horn and an isotropic antenna are taken into consideration.

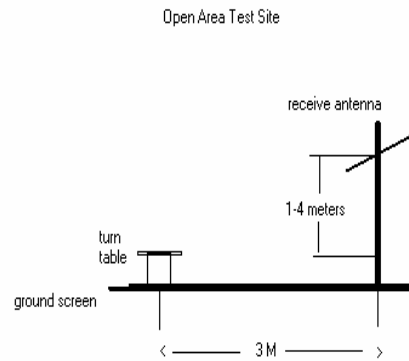

Figure 1-1. Diagram of 3-meter outdoor test range

Deviation from Measurement Procedure.....None

1.2 Scope

Measurement and determination of electromagnetic emissions (EME) of radio frequency devices including intentional and/or unintentional radiators for compliance with the technical rules and regulations of the Federal Communications Commission.

1.3 Testing Facility

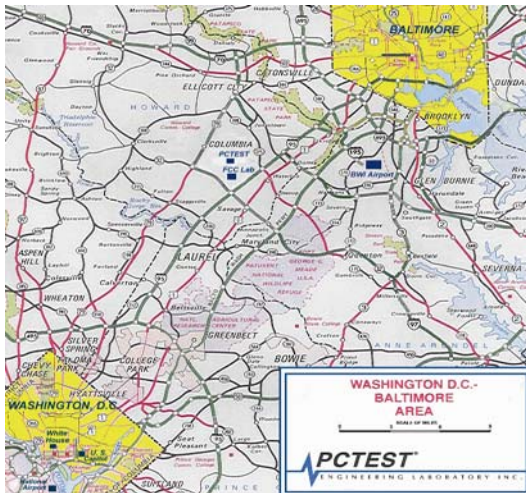

These measurement tests were conducted at PCTEST Engineering Laboratory, Inc. facility in New Concept Business Park, Guilford Industrial Park, Columbia, Maryland. The site address is 6660-B Dobbin Road, Columbia, MD 21045. The test site is one of the highest points in the Columbia area with an elevation of 390 feet above mean sea level. The site coordinates are 39° 11'15" N latitude and 76° 49'38" W longitude. The facility is 1.5 miles North of the FCC laboratory, and the ambient signal and ambient signal strength are approximately equal to those of the FCC laboratory. There are no FM or TV transmitters within 15 miles of the site. The detailed description of the measurement facility was found to be in compliance with the requirements of § 2.948 according to ANSI C63.4-2003 on January 27, 2006 and Industry Canada.

Figure 1-3. Map of the Greater Baltimore and Metropolitan Washington, D.C. area.

FCC ID: BEJCU400	PCTEST wireless	FCC Pt. 22/24 GSM MEASUREMENT REPORT		Reviewed by: Quality Manager
Test Report S/N: 0610110885	Test Dates: October 13-18, 2006	EUT Type: Dual-Band Dual-Mode GSM/WCDMA Phone with Bluetooth		Page 4 of 29

2.0 PRODUCT INFORMATION

2.1 Equipment Description

The Equipment Under Test (EUT) is the **LG Electronics USA Dual-Band Dual-Mode GSM/WCDMA Phone with Bluetooth FCC ID: BEJCU400**. The EUT consisted of the following component(s):



Manufacturer / Description	FCC ID	Serial Number
LG Electronics USA Dual-Band Dual-Mode GSM/WCDMA Phone with Bluetooth	BEJCU400	440015202000000

Table 2-1. EUT Equipment Description

2.2 EMI Suppression Device(s)/Modifications

EMI suppression device(s) added and/or modifications made during testing.

- None

FCC ID: BEJCU400	 FCC Pt. 22/24 GSM MEASUREMENT REPORT			Reviewed by: Quality Manager
Test Report S/N: 0610110885	Test Dates: October 13-18, 2006	EUT Type: Dual-Band Dual-Mode GSM/WCDMA Phone with Bluetooth		Page 5 of 29

3.0 DESCRIPTION OF TESTS

3.1 Occupied Bandwidth Emission Limits

§2.1049, 22.917(a), 24.238(a)

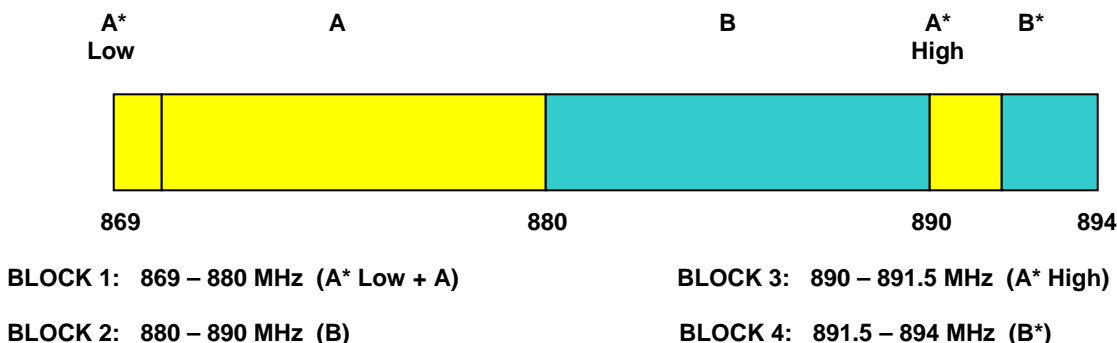

- a. On any frequency outside a licensee's frequency block, the power of any emission shall be attenuated below the transmitter power (P) by at least $43 + 10 \log(P)$ dB.
- b. Compliance with these provisions is based on the use of measurement instrumentation employing a resolution bandwidth of 1 MHz or greater. However, in the 1 MHz bands immediately outside and adjacent to the frequency block a resolution bandwidth of at least one percent of the emission bandwidth of the fundamental emission of the transmitter may be employed. The emission bandwidth is defined as the width of the signal between two points, one below the carrier center frequency and one above the carrier center frequency, outside of which all emission are attenuated at least 26 dB below the transmitter power.
- c. When measuring the emission limits, the nominal carrier frequency shall be adjusted as close to the licensee's frequency block edges, both upper and lower, as the design permits.
- d. The measurement of emission power can be expressed in peak or average values, provided they are expressed in the same parameters as the transmitter power.

3.2 Cellular - Base Frequency Blocks

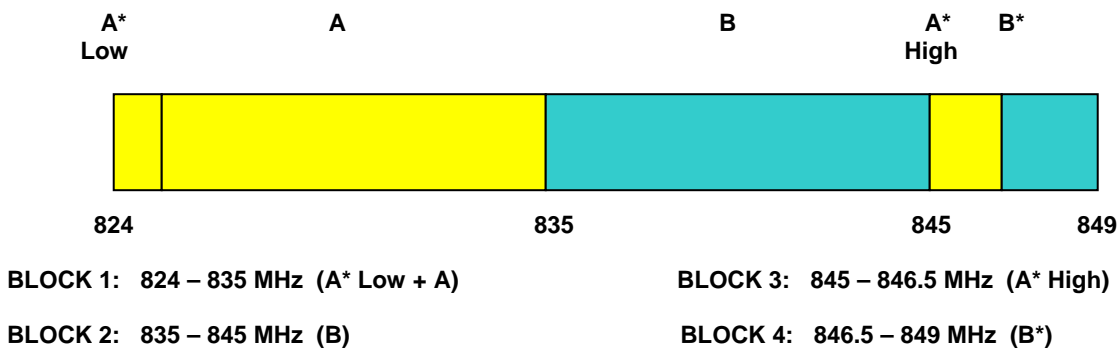

3.3 Cellular - Mobile Frequency Blocks



FCC ID: BEJCU400		FCC Pt. 22/24 GSM MEASUREMENT REPORT		Reviewed by: Quality Manager
Test Report S/N: 0610110885	Test Dates: October 13-18, 2006	EUT Type: Dual-Band Dual-Mode GSM/WCDMA Phone with Bluetooth		Page 6 of 29

3.4 PCS - Base Frequency Blocks

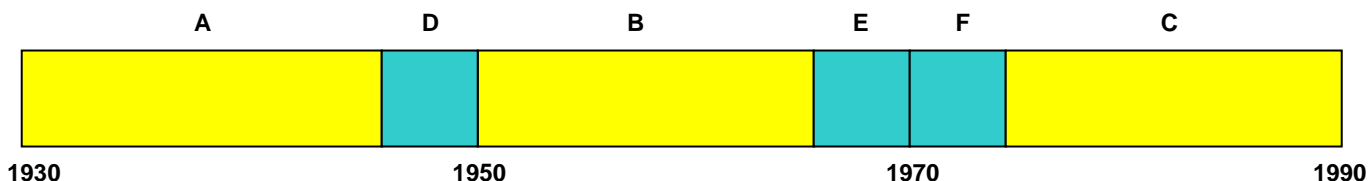

BLOCK 1: 1930 – 1945 MHz (A)

BLOCK 4: 1965 – 1970 MHz (E)

BLOCK 2: 1945 – 1950 MHz (D)

BLOCK 5: 1970 – 1975 MHz (F)

BLOCK 3: 1950 – 1965 MHz (B)

BLOCK 6: 1975 – 1990 MHz (C)

3.5 PCS - Mobile Frequency Blocks

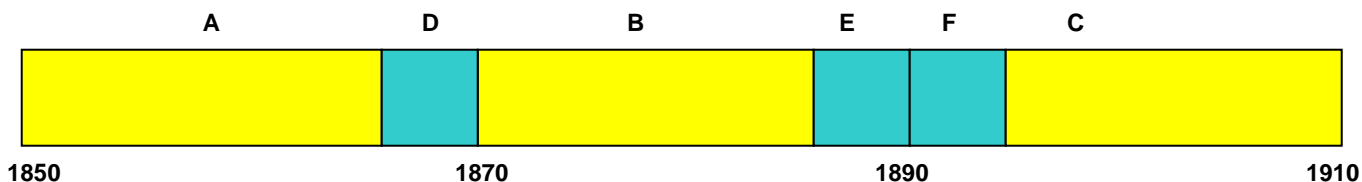

BLOCK 1: 1850 – 1865 MHz (A)

BLOCK 4: 1885 – 1890 MHz (E)

BLOCK 2: 1865 – 1870 MHz (D)

BLOCK 5: 1890 – 1895 MHz (F)



BLOCK 3: 1870 – 1885 MHz (B)

BLOCK 6: 1895 – 1910 MHz (C)

3.6 Spurious and Harmonic Emissions at Antenna Terminal

The level of the carrier and the various conducted spurious and harmonic frequencies is measured by means of a calibrated spectrum analyzer. The spectrum is scanned from the lowest frequency generated in the equipment up to 10 GHz. The transmitter is modulated with a 2500 Hz tone at a level of 16 dB greater than that required to provide 50% modulation.

At the input terminals of the spectrum analyzer, an isolator (RF circulator with one port terminated in 50 Ω) and an 870 MHz to 890 MHz band-pass filter is connected between the test transceiver (for conducted tests) or the receive antenna (for radiated tests) and the analyzer. The rejection of the band-pass filter to signals in the 825 – 845 MHz range is adequate to limit the transmit energy from the test transceiver which appears to a level which will allow the analyzer to measure signals less than -90 dBm. Calibration of the test receiver is performed in the 870 – 890 MHz range to insure accuracy to allow variation in the band-pass filter insertion loss to be calibrated.

FCC ID: BEJCU400	 FCC Pt. 22/24 GSM MEASUREMENT REPORT 		Reviewed by: Quality Manager
Test Report S/N: 0610110885	Test Dates: October 13-18, 2006	EUT Type: Dual-Band Dual-Mode GSM/WCDMA Phone with Bluetooth	Page 7 of 29

3.7 Frequencies

At the input terminals of the spectrum analyzer, an isolator (RF pad) and a high-pass filter are connected between the test transceiver (for conducted tests) or the receive antenna (for radiated tests) and the analyzer. The high-pass filter (signals below 1.6 GHz) is to limit the fundamental frequency from interfering with the measurement of low-level spurious and harmonic emissions and to ensure that the preamplifier is not saturated.

3.8 Radiated Spurious and Harmonic Emissions

§2.1051, 22.917(a), 24.238(a); RSS-132 (4.5.1) / RSS-133 (6.5.1)

Radiation and harmonic emissions are measured outdoors at our 3-meter test range. The equipment under test is placed on a wooden turntable 3-meters from the receive antenna. The receive antenna height and turntable rotations were adjusted for the highest reading on the receive spectrum analyzer. A half-wave dipole was substituted in place of the EUT. This dipole antenna was driven by a signal generator with the level of the signal generator being adjusted to obtain the same receive spectrum analyzer reading. This level is recorded. For readings above 1 GHz, the above procedure is repeated using horn antennas and the difference between the gain of the horn and an isotropic or dipole antenna are taken into consideration. This device was tested using a PCL of 0 in the PCS Band and a PCL of 5 in the Cellular Band.

3.9 Frequency Stability / Temperature Variation

§2.1055, 22.355, 24.235; RSS-132 (4.3) / RSS-133 (6.3)



The frequency stability of the transmitter is measured by:

- a.) **Temperature:** The temperature is varied from -30°C to +60°C using an environmental chamber.
- b.) **Primary Supply Voltage:** The primary supply voltage is varied from 85% to 115% of the voltage normally at the input to the device or at the power supply terminals if cables are not normally supplied.

Specification – The frequency stability shall be sufficient to ensure that the fundamental emission stays within the authorized frequency block. The frequency stability of the transmitter shall be maintained within ± 0.00025 (± 2.5 ppm) of the center frequency.

Time Period and Procedure:

1. The carrier frequency of the transmitter and the individual oscillators is measured at room temperature (22°C to 25°C to provide a reference).
2. The equipment is subjected to an overnight “soak” at -30°C without any power applied.
3. After the overnight “soak” at -30°C (usually 14-16 hours), the equipment is turned on in a “standby” condition for one minute before applying power to the transmitter. Measurement of the carrier frequency of the transmitter and the individual oscillators is made within a three minute interval after applying power to the transmitter.
4. Frequency measurements are made at 10°C interval up to room temperature. At least a period of one and one half-hour is provided to allow stabilization of the equipment at each temperature level.



FCC ID: BEJCU400	 FCC Pt. 22/24 GSM MEASUREMENT REPORT 		Reviewed by: Quality Manager
Test Report S/N: 0610110885	Test Dates: October 13-18, 2006	EUT Type: Dual-Band Dual-Mode GSM/WCDMA Phone with Bluetooth	Page 8 of 29

3.9 Frequency Stability / Temperature Variation (Cont'd)

§2.1055, 22.355, 24.235; RSS-132 (4.3) / RSS-133 (6.3)

5. Again the transmitter carrier frequency and the individual oscillators is measured at room temperature to begin measurement of the upper temperature levels.
6. Frequency measurements are at 10 intervals starting at -30°C up to +50°C allowing at least two hours at each temperature for stabilization. In all measurements the frequency is measured within three minutes after re-applying power to the transmitter.
7. The artificial load is mounted external to the temperature chamber.

NOTE: The EUT is tested down to the battery endpoint.



FCC ID: BEJCU400		FCC Pt. 22/24 GSM MEASUREMENT REPORT		Reviewed by: Quality Manager
Test Report S/N: 0610110885	Test Dates: October 13-18, 2006	EUT Type: Dual-Band Dual-Mode GSM/WCDMA Phone with Bluetooth		Page 9 of 29

4.0 TEST EQUIPMENT CALIBRATION DATA

Test Equipment Calibration is traceable to the National Institute of Standards and Technology (NIST).

TYPE	MODEL	CAL. DUE DATE	CAL. INTERVAL	SERIAL No.
Microwave Spectrum Analyzer	Agilent E4448A (3Hz-50GHz)	09/22/07	Annual	US42510244
Spectrum Analyzer	HP 8566B (100Hz-22GHz)	12/22/06	Annual	3638A08713
PSG Signal Generator	Agilent E8257D (250kHz-20GHz)	02/11/07	Annual	MY45470194
5 Watt Amplifier	5S1G4 (800MHz-4.2GHz)	N/A	N/A	22332
Universal Radio Communication Tester	CMU200	04/20/07	Annual	836370/079
Universal Power Meter	Gigatronics 8651A (50MHz-18GHz)	07/28/07	Annual	1834052
Power Sensor	Gigatronics 80701A	04/11/07	Annual	1833460
Quasi-Peak Adapter	HP 85650A	08/09/07	Annual	2043A00301
Preamplifier	HP 8449B (1-26.5GHz)	12/22/06	Annual	3008A00985
Attenuation/Switch Driver	HP 11713A	12/22/06	Annual	N/A
Preselector	HP 85685A (20Hz-2GHz)	12/22/06	Annual	N/A
6dB Res BW Spec. Analyzer Display	OPT 462	12/22/06	Annual	3701A22204
Ailtech/Eaton Adapter	CCA-7 CISPR/ANSI QP Adapter	12/19/06	Annual	0194-04082
Ailtech/Eaton Receiver	NM 37/57A (30MHz – 1GHz)	06/07/07	Annual	0805-03334
Broadband Amplifier (2)	HP 8447D (0.1 – 1300MHz)	N/A	N/A	2443A01900, 1937A03348
Horn Antenna	EMCO Model 3115 (1-18GHz)	08/25/07	Bi Annual	9704-5182
Horn Antenna	EMCO Model 3116 (18-40GHz)	08/25/07	Bi Annual	9203-2178
Roberts Dipoles	Compliance Design (1 set) A100	08/31/07	Bi Annual	5118
EMCO Dipoles (2)	N/A	05/08/08	Bi Annual	00023951
EMCO LISN (3)	3816/2, 3816/2, 3725/2	10/26/06	Annual	1077, 1079, 2099
10dB Attenuator	HP 8493B	N/A	N/A	N/A
Microwave Cables	MicroCoax (1.0-26.5GHz)	02/26/07	Annual	N/A
Shielded Screen Room	RF Lindgren Model 26-2/2-0	N/A	N/A	6710 (PCT270)
Shielded Semi-Anechoic Chamber	Ray Proof Model S81	N/A	N/A	R2437 (PCT278)
Environmental Chamber	Associated Systems 1025	08/08/07	Annual	PCT285

Table 4-1. Test Equipment

FCC ID: BEJCU400	 FCC Pt. 22/24 GSM MEASUREMENT REPORT 		Reviewed by: Quality Manager
Test Report S/N: 0610110885	Test Dates: October 13-18, 2006	EUT Type: Dual-Band Dual-Mode GSM/WCDMA Phone with Bluetooth	Page 10 of 29

5.0 SAMPLE CALCULATIONS

Emission Designator

Emission Designator = 250KGXW

GSM BW = 250 kHz

G = Phase Modulation



X = Cases not otherwise covered

W = Combination (Audio/Data)

Spurious Radiated Emission - PCS Band

Example: Channel 512 PCS Mode 2nd Harmonic (3700.40 MHz)

The receive analyzer reading at 3 meters with the EUT on the turntable was -81.0 dBm. The gain of the substituted antenna is 8.1 dBi. The signal generator connected to the substituted antenna terminals is adjusted to produce a reading of -81.0 dBm on the receive analyzer. The loss of the cable between the signal generator and the terminals of the substituted antenna is 2.0 dB at 3700.40 MHz. So 6.1 dB is added to the signal generator reading of -30.9 dBm yielding -24.80 dBm. The fundamental EIRP was 25.501 dBm so this harmonic was 25.501 dBm $- (-24.80) = 50.3$ dBc.

FCC ID: BEJCU400	 FCC Pt. 22/24 GSM MEASUREMENT REPORT			Reviewed by: Quality Manager
Test Report S/N: 0610110885	Test Dates: October 13-18, 2006	EUT Type: Dual-Band Dual-Mode GSM/WCDMA Phone with Bluetooth		Page 11 of 29

6.0 TEST RESULTS

Summary

The intentional radiator has been tested in a simulated typical installation to demonstrate compliance with the relevant FCC performance and procedural standards.

The radio was transmitting at full power on the specified channels. The channels tested are high, middle and low of the allocated bands.



Final system data was gathered in a mode that tended to maximize emissions by varying the orientation of the EUT, orientation of power and I/O cabling, antenna search height, and antenna polarization.

Method/System: PCS Licensed Transmitter Held to Ear (PCE)

Mode(s): GSM

FCC Part Section(s)	RSS Section	Test Description	Test Limit	Test Condition	Test Result
TRANSMITTER MODE (TX)					
2.1049, 22.917(a), 24.238(a)	N/A	Occupied Bandwidth	N/A	CONDUCTED	N/A
22.917(a), 24.238(a)	RSS-132 (4.5.1) / RSS-133 (6.5.1)	Band Edge / Conducted Spurious Emissions	< 43 + log ₁₀ (P[Watts]) at Band Edge / for all out-of-band emissions		PASS
2.1046	N/A	Transmitter Conducted Output Power	N/A		N/A
22.913(a)(2)	RSS-132 (4.4) [SRSP-503(5.1.3)]	Effective Radiated Power	< 7 Watts max. ERP (<6.3 Watts max. ERP (IC))	RADIATED	PASS
24.232(c)	RSS-133 (6.4) [SRSP-510 (5.1.2)]	Equivalent Isotropic Radiated Power	< 2 Watts max. EIRP		PASS
2.1051, 22.917(a), 24.238(a)	RSS-132 (4.5.1) / RSS-133 (6.5.1)	Undesirable Emissions	< 43 + log ₁₀ (P[Watts]) for all out-of-band emissions		PASS
2.1055, 22.355, 24.235	RSS-132 (4.3) / RSS-133 (6.3)	Frequency Stability	< 2.5 ppm		PASS
RECEIVER MODE (RX)					
15.107	RSS-210 (7.4)	AC Conducted Emissions 150kHz – 30MHz	EN55022	Line Conducted	PASS
15.109	RSS-132 (4.6) / RSS-133(6.7(a) / [RSS-Gen (7.2.2)] / RSS-210 (7.3)	General Field Strength Limits (Restricted Bands and Radiated Emissions Limits)	< FCC 15.209 limits or < RSS-210 table 3 limits	RADIATED (30MHz-1GHz) (1-25 GHz)	PASS
RF EXPOSURE (SAR)					
2.1093	RSS-102	SAR Test or MPE	1.6 W/kg (SAR Limit)	3 Channels	PASS

Table 6-1. Summary of Test Results

FCC ID: BEJCU400	 FCC Pt. 22/24 GSM MEASUREMENT REPORT			Reviewed by: Quality Manager
Test Report S/N: 0610110885	Test Dates: October 13-18, 2006	EUT Type: Dual-Band Dual-Mode GSM/WCDMA Phone with Bluetooth	Page 12 of 29	

6.1 Conducted Output Power

§2.1046

This device was tested using a PCL of 0 in the PCS Band and a PCL of 5 in the Cellular Band.

Band	Channel	Power Control Level	Conducted Power
			[dBm]
Cellular	128	5	32.5
	190	5	32.4
	251	5	32.0
PCS	512	0	29.2
	661	0	28.9
	810	0	28.8

Table 6-2. GSM Conducted Output Powers

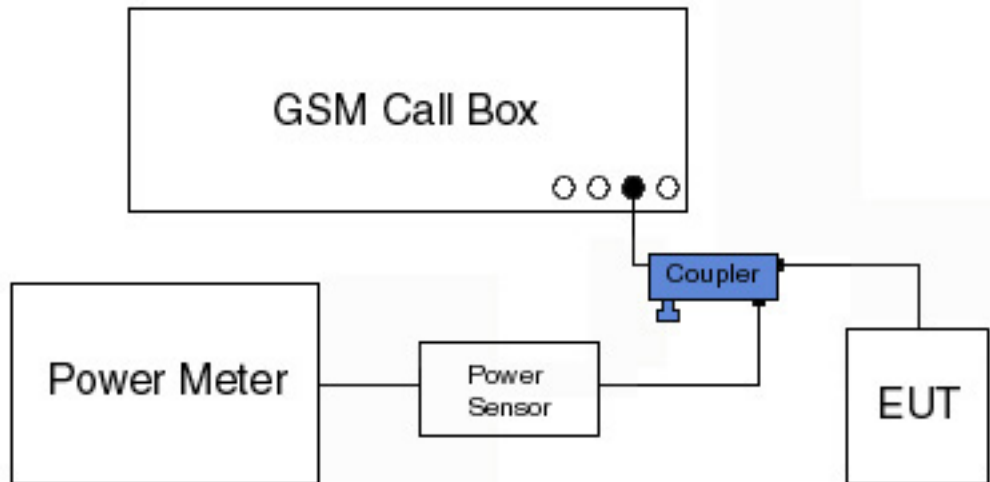



Figure 6-1. GSM Conducted Power Test Setup Diagram

FCC ID: BEJCU400	 FCC Pt. 22/24 GSM MEASUREMENT REPORT		Reviewed by: Quality Manager
Test Report S/N: 0610110885	Test Dates: October 13-18, 2006	EUT Type: Dual-Band Dual-Mode GSM/WCDMA Phone with Bluetooth	Page 13 of 29

6.2 Effective Radiated Power Output Data

§22.913(a)(2)

POWER: High (GSM Mode)

Freq. Tuned (MHz)	Mode	REF. LEVEL (dBm)	POL (H/V)	ERP (W)	ERP (dBm)	BATTERY
824.20	GSM 850	-8.770	V	1.779	32.503	Standard
836.60	GSM 850	-9.210	V	1.668	32.223	Standard
848.80	GSM 850	-9.370	V	1.664	32.213	Standard
824.20	GSM 850	-8.900	V	1.727	32.373	Extended
824.20	EDGE 850	-10.980	V	1.070	30.293	Standard



Table 6-3. Effective Radiated Power Output Data

NOTES:

Effective Radiated Power Output Measurements by Substitution Method according to ANSI/TIA/EIA-603-C-2004, Aug. 17, 2004:

The EUT was placed on a wooden turn table 3-meters from the receive antenna. The receive antenna height and turntable rotation was adjusted for the highest reading on the receive spectrum analyzer. For CDMA signals, a peak detector is used, with RBW = VBW = 3 MHz. For WCDMA signals, a peak detector is used, with RBW = VBW = 5 MHz. For AMPS, GSM, and NADC TDMA signals, a peak detector is used, with RBW = VBW = 1 MHz. A half-wave dipole was substituted in place of the EUT. This dipole antenna was driven by a signal generator and the level of the signal generator was adjusted to obtain the same receive spectrum analyzer reading. The conducted power at the terminals of the dipole is measured. The ERP is recorded.

This device was tested using a PCL of 0 in the PCS Band and a PCL of 5 in the Cellular Band.

FCC ID: BEJCU400	 FCC Pt. 22/24 GSM MEASUREMENT REPORT			Reviewed by: Quality Manager
Test Report S/N: 0610110885	Test Dates: October 13-18, 2006	EUT Type: Dual-Band Dual-Mode GSM/WCDMA Phone with Bluetooth		Page 14 of 29

6.3 Equivalent Isotropic Radiated Power Output Data §24.232(c)

Radiated measurements at 3 meters

Supply Voltage: 3.7 VDC

Modulation: PCS GSM

FREQ. (MHz)	Mode	REF. LEVEL (dBm)	POL (H/V)	Azimuth (o angle)	EIRP (dBm)	EIRP (W)	Battery
1850.20	GSM 1900	-10.380	H	90	32.701	1.863	Standard
1880.00	GSM 1900	-10.700	H	90	32.551	1.799	Standard
1909.80	GSM 1900	-10.980	H	90	32.441	1.754	Standard
1850.20	GSM 1900	-10.620	H	90	32.461	1.762	Extended
1850.20	EDGE 1900	-12.830	H	90	30.421	1.104	Standard



Table 6-4. Equivalent Isotropic Radiated Power Output Data

NOTES:

Equivalent Isotropic Radiated Power Measurements by Substitution Method according to ANSI/TIA/EIA-603-C-2004, Aug. 17, 2004:

The EUT was placed on a wooden turn table 3-meters from the receive antenna. The receive antenna height and turntable rotation was adjusted for the highest reading on the receive spectrum analyzer. For CDMA signals, a peak detector is used, with RBW = VBW = 3 MHz. For WCDMA signals, a peak detector is used, with RBW = VBW = 5 MHz. For AMPS, GSM, and NADC TDMA signals, a peak detector is used, with RBW = VBW = 1 MHz. A Horn antenna was substituted in place of the EUT. This Horn antenna was driven by a signal generator and the level of the signal generator was adjusted to obtain the same receive spectrum analyzer reading. The conducted power at the terminals of the Horn antenna is measured. The difference between the gain of the horn and an isotropic antenna is taken into consideration and the EIRP is recorded.

This device was tested using a PCL of 0 in the PCS Band and a PCL of 5 in the Cellular Band.

FCC ID: BEJCU400	 FCC Pt. 22/24 GSM MEASUREMENT REPORT 		Reviewed by: Quality Manager
Test Report S/N: 0610110885	Test Dates: October 13-18, 2006	EUT Type: Dual-Band Dual-Mode GSM/WCDMA Phone with Bluetooth	Page 15 of 29

6.4 Cellular GSM Radiated Measurements
§2.1051, 22.917(a)

Field Strength of SPURIOUS Radiation

Field Strength of SPURIOUS Radiation

OPERATING FREQUENCY: 824.20 MHz
 CHANNEL: 128
 MEASURED OUTPUT POWER: 32.503 dBm = 1.779 W
 MODULATION SIGNAL: GSM
 DISTANCE: 3 meters
 LIMIT: $43 + 10 \log_{10}(W)$: 45.50 dBc

FREQ. (MHz)	LEVEL @ ANTENNA TERMINALS (dBm)	SUBSTITUTE ANTENNA GAIN (dBd)	CORRECT GENERATOR LEVEL (dBm)	POL (H/V)	(dBc)
1648.40	-44.63	6.10	-38.53	V	71.0
2472.60	-45.05	6.70	-38.35	V	70.9
3296.80	-46.19	6.80	-39.39	V	71.9
4121.00	-50.78	6.50	-44.28	V	76.8
4945.20	-52.78	7.00	-45.78	V	78.3



Table 6-5. Radiated Spurious Data (Cellular GSM Mode – Ch. 128)

NOTES:

Radiated Spurious Emission Measurements by Substitution Method
according to ANSI/TIA/EIA-603-C-2004, Aug. 17, 2004:

The EUT was placed on a wooden turn table 3-meters from the receive antenna. The receive antenna height and turntable rotation was adjusted for the highest reading on the receive spectrum analyzer. For CDMA signals, a peak detector is used, with RBW = VBW = 3 MHz. For WCDMA signals, a peak detector is used, with RBW = VBW = 5 MHz. For AMPS, GSM, and NADC TDMA signals, a peak detector is used, with RBW = VBW = 1 MHz. A half-wave dipole was substituted in place of the EUT. This dipole antenna was driven by a signal generator and the level of the signal generator was adjusted to obtain the same receive spectrum analyzer reading. This spurious level is recorded. For readings above 1GHz, the above procedure is repeated using horn antennas and the difference between the gain of the horn and an isotropic or dipole antenna are taken into consideration.

This device was tested using a PCL of 0 in the PCS Band and a PCL of 5 in the Cellular Band.

FCC ID: BEJCU400	 FCC Pt. 22/24 GSM MEASUREMENT REPORT 		Reviewed by: Quality Manager
Test Report S/N: 0610110885	Test Dates: October 13-18, 2006	EUT Type: Dual-Band Dual-Mode GSM/WCDMA Phone with Bluetooth	Page 16 of 29

Cellular GSM Radiated Measurements (Cont'd)
§2.1051, 22.917(a)

Field Strength of SPURIOUS Radiation

Field Strength of SPURIOUS Radiation

OPERATING FREQUENCY: 836.60 MHz
 CHANNEL: 190
 MEASURED OUTPUT POWER: 32.503 dBm = 1.779 W
 MODULATION SIGNAL: GSM
 DISTANCE: 3 meters
 LIMIT: $43 + 10 \log_{10}(W) =$ 45.50 dBc

FREQ. (MHz)	LEVEL @ ANTENNA TERMINALS (dBm)	SUBSTITUTE ANTENNA GAIN (dBd)	CORRECT GENERATOR LEVEL (dBm)	POL (H/V)	(dBc)
1673.20	-43.03	6.10	-36.93	V	69.4
2509.80	-44.56	6.70	-37.86	V	70.4
3346.40	-44.40	6.80	-37.60	V	70.1
4183.00	-48.81	6.50	-42.31	V	74.8
5019.60	-50.20	7.00	-43.20	V	75.7



Table 6-6. Radiated Spurious Data (Cellular GSM Mode – Ch. 190)

NOTES:

Radiated Spurious Emission Measurements by Substitution Method
according to ANSI/TIA/EIA-603-C-2004, Aug. 17, 2004:

The EUT was placed on a wooden turn table 3-meters from the receive antenna. The receive antenna height and turntable rotation was adjusted for the highest reading on the receive spectrum analyzer. For CDMA signals, a peak detector is used, with RBW = VBW = 3 MHz. For WCDMA signals, a peak detector is used, with RBW = VBW = 5 MHz. For AMPS, GSM, and NADC TDMA signals, a peak detector is used, with RBW = VBW = 1 MHz. A half-wave dipole was substituted in place of the EUT. This dipole antenna was driven by a signal generator and the level of the signal generator was adjusted to obtain the same receive spectrum analyzer reading. This spurious level is recorded. For readings above 1GHz, the above procedure is repeated using horn antennas and the difference between the gain of the horn and an isotropic or dipole antenna are taken into consideration.

This device was tested using a PCL of 0 in the PCS Band and a PCL of 5 in the Cellular Band.

FCC ID: BEJCU400	 FCC Pt. 22/24 GSM MEASUREMENT REPORT 		Reviewed by: Quality Manager
Test Report S/N: 0610110885	Test Dates: October 13-18, 2006	EUT Type: Dual-Band Dual-Mode GSM/WCDMA Phone with Bluetooth	Page 17 of 29



Cellular GSM Radiated Measurements (Cont'd)

§2.1051, 22.917(a)

Field Strength of SPURIOUS Radiation

OPERATING FREQUENCY: 848.80 MHz
 CHANNEL: 251
 MEASURED OUTPUT POWER: 32.503 dBm = 1.779 W
 MODULATION SIGNAL: GSM
 DISTANCE: 3 meters
 LIMIT: $43 + 10 \log_{10}(W) =$ 45.50 dBc

FREQ. (MHz)	LEVEL @ ANTENNA TERMINALS (dBm)	SUBSTITUTE ANTENNA GAIN (dBd)	CORRECT GENERATOR LEVEL (dBm)	POL (H/V)	(dBc)
1697.60	-42.24	6.10	-36.14	V	68.6
2546.40	-43.36	6.70	-36.66	V	69.2
3395.20	-45.31	6.80	-38.51	V	71.0
4244.00	-50.15	6.50	-43.65	V	76.2
5092.80	-49.94	7.00	-42.94	V	75.4

Table 6-7. Radiated Spurious Data (Cellular GSM Mode – Ch. 251)

NOTES:

Radiated Spurious Emission Measurements by Substitution Method
 according to ANSI/TIA/EIA-603-C-2004, Aug. 17, 2004:

The EUT was placed on a wooden turn table 3-meters from the receive antenna. The receive antenna height and turntable rotation was adjusted for the highest reading on the receive spectrum analyzer. For CDMA signals, a peak detector is used, with RBW = VBW = 3 MHz. For WCDMA signals, a peak detector is used, with RBW = VBW = 5 MHz. For AMPS, GSM, and NADC TDMA signals, a peak detector is used, with RBW = VBW = 1 MHz. A half-wave dipole was substituted in place of the EUT. This dipole antenna was driven by a signal generator and the level of the signal generator was adjusted to obtain the same receive spectrum analyzer reading. This spurious level is recorded. For readings above 1GHz, the above procedure is repeated using horn antennas and the difference between the gain of the horn and an isotropic or dipole antenna are taken into consideration.

This device was tested using a PCL of 0 in the PCS Band and a PCL of 5 in the Cellular Band.

FCC ID: BEJCU400	FCC Pt. 22/24 GSM MEASUREMENT REPORT		Reviewed by: Quality Manager
Test Report S/N: 0610110885	Test Dates: October 13-18, 2006	EUT Type: Dual-Band Dual-Mode GSM/WCDMA Phone with Bluetooth	Page 18 of 29

6.5 PCS GSM Radiated Measurements
§2.1051, 24.238(a)

Field Strength of SPURIOUS Radiation

8.5 PCS GSM Radiated Measurements

Field Strength of SPURIOUS Radiation

OPERATING FREQUENCY: 1850.20 MHz
 CHANNEL: 512
 MEASURED OUTPUT POWER: 32.701 dBm = 1.863 W
 MODULATION SIGNAL: GSM
 DISTANCE: 3 meters
 LIMIT: $43 + 10 \log_{10} (W) =$ 45.70 dBc

FREQ. (MHz)	LEVEL @ ANTENNA TERMINALS (dBm)	SUBSTITUTE ANTENNA GAIN (dBd)	CORRECT GENERATOR LEVEL (dBm)	POL (H/V)	(dBc)
3700.40	-48.10	6.10	-42.00	H	74.7
5550.60	-39.85	6.70	-33.15	H	65.8
7400.80	-45.17	6.80	-38.37	H	71.1
9251.00	-85.68	6.50	-79.18	H	111.9
11101.20	-84.38	7.00	-77.38	H	110.1



Table 6-8. Radiated Spurious Data (PCS GSM Mode – Ch. 512)

NOTES:

Radiated Spurious Emission Measurements by Substitution Method
 according to ANSI/TIA/EIA-603-C-2004, Aug. 17, 2004:

The EUT was placed on a wooden turn table 3-meters from the receive antenna. The receive antenna height and turntable rotation was adjusted for the highest reading on the receive spectrum analyzer. For CDMA signals, a peak detector is used, with RBW = VBW = 3 MHz. For WCDMA signals, a peak detector is used, with RBW = VBW = 5 MHz. For AMPS, GSM, and NADC TDMA signals, a peak detector is used, with RBW = VBW = 1 MHz. A half-wave dipole was substituted in place of the EUT. This dipole antenna was driven by a signal generator and the level of the signal generator was adjusted to obtain the same receive spectrum analyzer reading. This spurious level is recorded. For readings above 1GHz, the above procedure is repeated using horn antennas and the difference between the gain of the horn and an isotropic or dipole antenna are taken into consideration.

This device was tested using a PCL of 0 in the PCS Band and a PCL of 5 in the Cellular Band.

FCC ID: BEJCU400	 FCC Pt. 22/24 GSM MEASUREMENT REPORT 		Reviewed by: Quality Manager
Test Report S/N: 0610110885	Test Dates: October 13-18, 2006	EUT Type: Dual-Band Dual-Mode GSM/WCDMA Phone with Bluetooth	Page 19 of 29



PCS GSM Radiated Measurements (Cont'd)
§2.1051, 24.238(a)

Field Strength of SPURIOUS Radiation

OPERATING FREQUENCY: 1880.00 MHz
 CHANNEL: 661
 MEASURED OUTPUT POWER: 32.701 dBm = 1.863 W
 MODULATION SIGNAL: GSM
 DISTANCE: 3 meters
 LIMIT: $43 + 10 \log_{10}(W) =$ 45.70 dBc

FREQ. (MHz)	LEVEL @ ANTENNA TERMINALS (dBm)	SUBSTITUTE ANTENNA GAIN (dBd)	CORRECT GENERATOR LEVEL (dBm)	POL (H/V)	(dBc)
3760.00	-48.25	6.10	-42.15	H	74.8
5640.00	-40.03	6.70	-33.33	H	66.0
7520.00	-43.42	6.80	-36.62	H	69.3
9400.00	-85.78	6.50	-79.28	H	112.0
11280.00	-83.78	7.00	-76.78	H	109.5

Table 6-9. Radiated Spurious Data (PCS GSM Mode – Ch. 661)

NOTES:

Radiated Spurious Emission Measurements by Substitution Method according to ANSI/TIA/EIA-603-C-2004, Aug. 17, 2004:

The EUT was placed on a wooden turn table 3-meters from the receive antenna. The receive antenna height and turntable rotation was adjusted for the highest reading on the receive spectrum analyzer. For CDMA signals, a peak detector is used, with RBW = VBW = 3 MHz. For WCDMA signals, a peak detector is used, with RBW = VBW = 5 MHz. For AMPS, GSM, and NADC TDMA signals, a peak detector is used, with RBW = VBW = 1 MHz. A half-wave dipole was substituted in place of the EUT. This dipole antenna was driven by a signal generator and the level of the signal generator was adjusted to obtain the same receive spectrum analyzer reading. This spurious level is recorded. For readings above 1GHz, the above procedure is repeated using horn antennas and the difference between the gain of the horn and an isotropic or dipole antenna are taken into consideration.

This device was tested using a PCL of 0 in the PCS Band and a PCL of 5 in the Cellular Band.

FCC ID: BEJCU400	FCC Pt. 22/24 GSM MEASUREMENT REPORT		Reviewed by: Quality Manager
Test Report S/N: 0610110885	Test Dates: October 13-18, 2006	EUT Type: Dual-Band Dual-Mode GSM/WCDMA Phone with Bluetooth	Page 20 of 29

PCS GSM Radiated Measurements (Cont'd)

§2.1051, 24.238(a)

Field Strength of SPURIOUS Radiation

OPERATING FREQUENCY: 1909.80 MHz
 CHANNEL: 810
 MEASURED OUTPUT POWER: 32.701 dBm = 1.863 W
 MODULATION SIGNAL: GSM
 DISTANCE: 3 meters
 LIMIT: $43 + 10 \log_{10}(W) =$ 45.70 dBc

FREQ. (MHz)	LEVEL @ ANTENNA TERMINALS (dBm)	SUBSTITUTE ANTENNA GAIN (dBd)	CORRECT GENERATOR LEVEL (dBm)	POL (H/V)	(dBc)
3819.60	-48.69	6.10	-42.59	H	75.3
5729.40	-36.87	6.70	-30.17	H	62.9
7639.20	-47.85	6.80	-41.05	H	73.7
9549.00	-85.68	6.50	-79.18	H	111.9
11458.80	-83.98	7.00	-76.98	H	109.7



Table 6-10. Radiated Spurious Data (PCS GSM Mode – Ch. 810)

NOTES:

Radiated Spurious Emission Measurements by Substitution Method
 according to ANSI/TIA/EIA-603-C-2004, Aug. 17, 2004:

The EUT was placed on a wooden turn table 3-meters from the receive antenna. The receive antenna height and turntable rotation was adjusted for the highest reading on the receive spectrum analyzer. For CDMA signals, a peak detector is used, with RBW = VBW = 3 MHz. For WCDMA signals, a peak detector is used, with RBW = VBW = 5 MHz. For AMPS, GSM, and NADC TDMA signals, a peak detector is used, with RBW = VBW = 1 MHz. A half-wave dipole was substituted in place of the EUT. This dipole antenna was driven by a signal generator and the level of the signal generator was adjusted to obtain the same receive spectrum analyzer reading. This spurious level is recorded. For readings above 1GHz, the above procedure is repeated using horn antennas and the difference between the gain of the horn and an isotropic or dipole antenna are taken into consideration.

This device was tested using a PCL of 0 in the PCS Band and a PCL of 5 in the Cellular Band.

FCC ID: BEJCU400	 FCC Pt. 22/24 GSM MEASUREMENT REPORT 		Reviewed by: Quality Manager
Test Report S/N: 0610110885	Test Dates: October 13-18, 2006	EUT Type: Dual-Band Dual-Mode GSM/WCDMA Phone with Bluetooth	Page 21 of 29

6.6 Cellular GSM Frequency Stability Measurements

§2.1055

OPERATING FREQUENCY: 836,600,024 Hz

CHANNEL: 190

REFERENCE VOLTAGE: 3.7 VDC



DEVIATION LIMIT: ± 0.00025 % or 2.5 ppm

VOLTAGE (%)	POWER (VDC)	TEMP (°C)	FREQ. (Hz)	Freq. Dev. (Hz)	Deviation (%)
100 %	3.70	+ 20 (Ref)	836,600,024	0.00	0.000000
100 %		- 30	836,599,932	92.03	0.000011
100 %		- 20	836,600,091	-66.93	-0.000008
100 %		- 10	836,599,848	175.69	0.000021
100 %		0	836,599,882	142.22	0.000017
100 %		+ 10	836,599,823	200.78	0.000024
100 %		+ 20	836,600,024	0.00	0.000000
100 %		+ 25	836,599,865	158.95	0.000019
100 %		+ 30	836,599,781	242.61	0.000029
100 %		+ 40	836,599,823	200.78	0.000024
100 %		+ 50	836,599,765	259.35	0.000031
100 %		+ 60	836,599,790	234.25	0.000028
85 %		3.17	+ 20	836,600,024	0.00
115 %	4.26	+ 20	836,600,024	0.00	0.000000
BATT. ENDPOINT	3.08	+ 20	836,600,024	0.00	0.000000

Table 6-11. Frequency Stability Data (Cellular GSM Mode – Ch. 190)

Note:

Standard batteries were used to perform this test.

FCC ID: BEJCU400	 FCC Pt. 22/24 GSM MEASUREMENT REPORT 		Reviewed by: Quality Manager
Test Report S/N: 0610110885	Test Dates: October 13-18, 2006	EUT Type: Dual-Band Dual-Mode GSM/WCDMA Phone with Bluetooth	Page 22 of 29

Cellular GSM Frequency Stability Measurements (Cont'd)

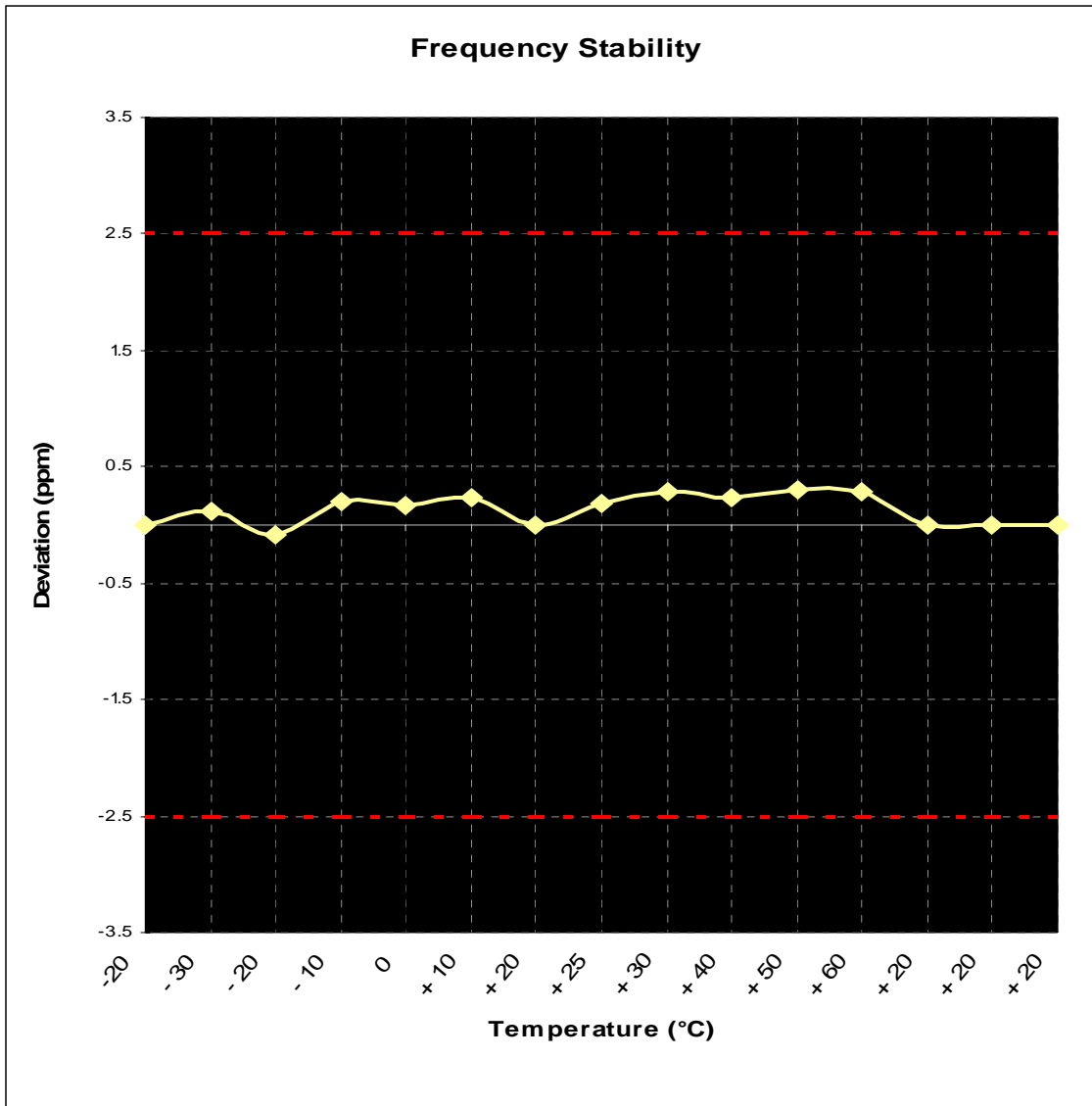

§2.1055



Plot 6-1. Frequency Stability Graph (Cellular GSM Mode – Ch. 190)

Note:

Standard batteries were used to perform this test.

FCC ID: BEJCU400	 FCC Pt. 22/24 GSM MEASUREMENT REPORT		Reviewed by: Quality Manager
Test Report S/N: 0610110885	Test Dates: October 13-18, 2006	EUT Type: Dual-Band Dual-Mode GSM/WCDMA Phone with Bluetooth	Page 23 of 29

6.7 PCS GSM Frequency Stability Measurements
§2.1055, 24.235

OPERATING FREQUENCY: 1,880,000,007 Hz

CHANNEL: 661

REFERENCE VOLTAGE: 3.7 VDC



DEVIATION LIMIT: ± 0.00025 % or 2.5 ppm

VOLTAGE (%)	POWER (VDC)	TEMP (°C)	FREQ. (Hz)	Freq. Dev. (Hz)	Deviation (%)
100 %	3.70	+ 20 (Ref)	1,880,000,007	0.00	0.000000
100 %		- 30	1,880,000,157	-150.40	-0.000008
100 %		- 20	1,880,000,045	-37.60	-0.000002
100 %		- 10	1,879,999,875	131.60	0.000007
100 %		0	1,879,999,725	282.00	0.000015
100 %		+ 10	1,879,999,612	394.80	0.000021
100 %		+ 20	1,880,000,007	0.00	0.000000
100 %		+ 25	1,879,999,349	658.00	0.000035
100 %		+ 30	1,879,999,744	263.20	0.000014
100 %		+ 40	1,879,999,612	394.80	0.000021
100 %		+ 50	1,879,999,499	507.60	0.000027
100 %		+ 60	1,879,999,462	545.20	0.000029
85 %		3.15	+ 20	1,880,000,007	0.00
115 %	4.26	+ 20	1,880,000,007	0.00	0.000000
BATT. ENDPOINT	3.12	+ 20	1,880,000,007	0.00	0.000000

Table 6-12. Frequency Stability Data (PCS GSM Mode – Ch. 661)

Note:

Standard batteries were used to perform this test.

FCC ID: BEJCU400	 FCC Pt. 22/24 GSM MEASUREMENT REPORT 		Reviewed by: Quality Manager
Test Report S/N: 0610110885	Test Dates: October 13-18, 2006	EUT Type: Dual-Band Dual-Mode GSM/WCDMA Phone with Bluetooth	Page 24 of 29

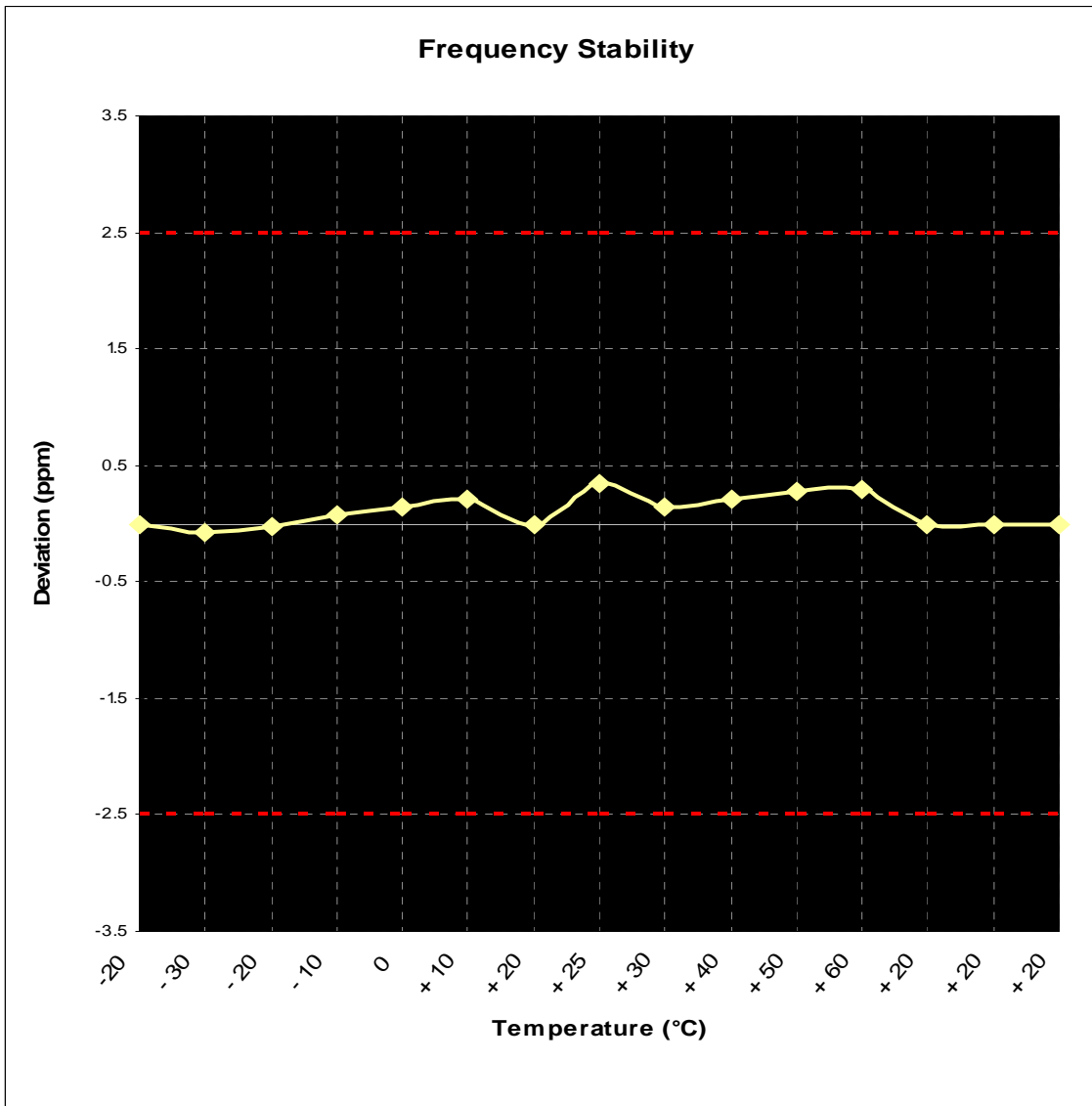

PCS GSM Frequency Stability Measurements (Cont'd)
\$2.1055, 24.235



Plot 6-2. Frequency Stability Graph (PCS GSM Mode – Ch. 661)

Note:

Standard batteries were used to perform this test.

FCC ID: BEJCU400	 FCC Pt. 22/24 GSM MEASUREMENT REPORT		Reviewed by: Quality Manager
Test Report S/N: 0610110885	Test Dates: October 13-18, 2006	EUT Type: Dual-Band Dual-Mode GSM/WCDMA Phone with Bluetooth	Page 25 of 29

7.0 CONCLUSION

The data collected shows that the LG Electronics USA Dual-Band Dual-Mode GSM/WCDMA Phone with Bluetooth FCC ID: BEJCU400 complies with all the requirements of Parts 2, 22, and 24 of the FCC rules.





FCC ID: BEJCU400		FCC Pt. 22/24 GSM MEASUREMENT REPORT		Reviewed by: Quality Manager
Test Report S/N: 0610110885	Test Dates: October 13-18, 2006	EUT Type: Dual-Band Dual-Mode GSM/WCDMA Phone with Bluetooth		Page 26 of 29

EXHIBIT A - PLOT(S) OF EMISSIONS

FCC ID: BEJCU400		FCC Pt. 22/24 GSM MEASUREMENT REPORT		Reviewed by: Quality Manager
Test Report S/N: 0610110885	Test Dates: October 13-18, 2006	EUT Type: Dual-Band Dual-Mode GSM/WCDMA Phone with Bluetooth		Page 27 of 29



Plot A-1. Conducted Spurious Plot (Cellular GSM Mode – Ch. 128)

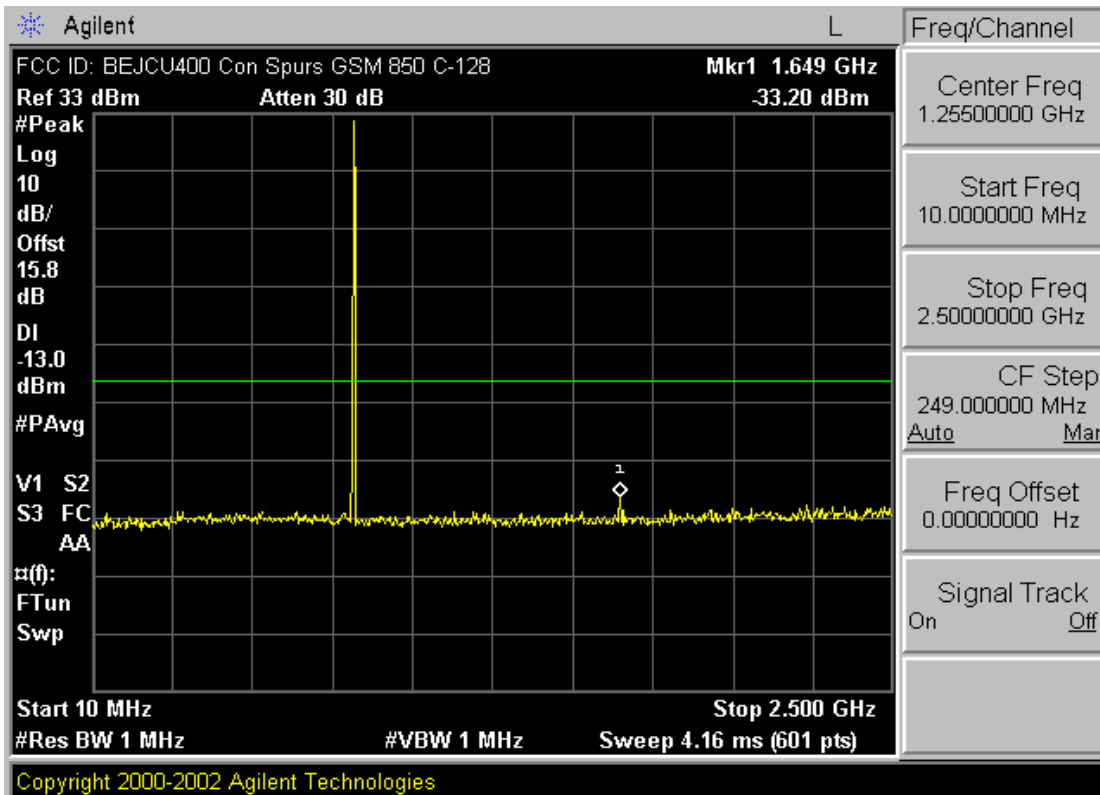
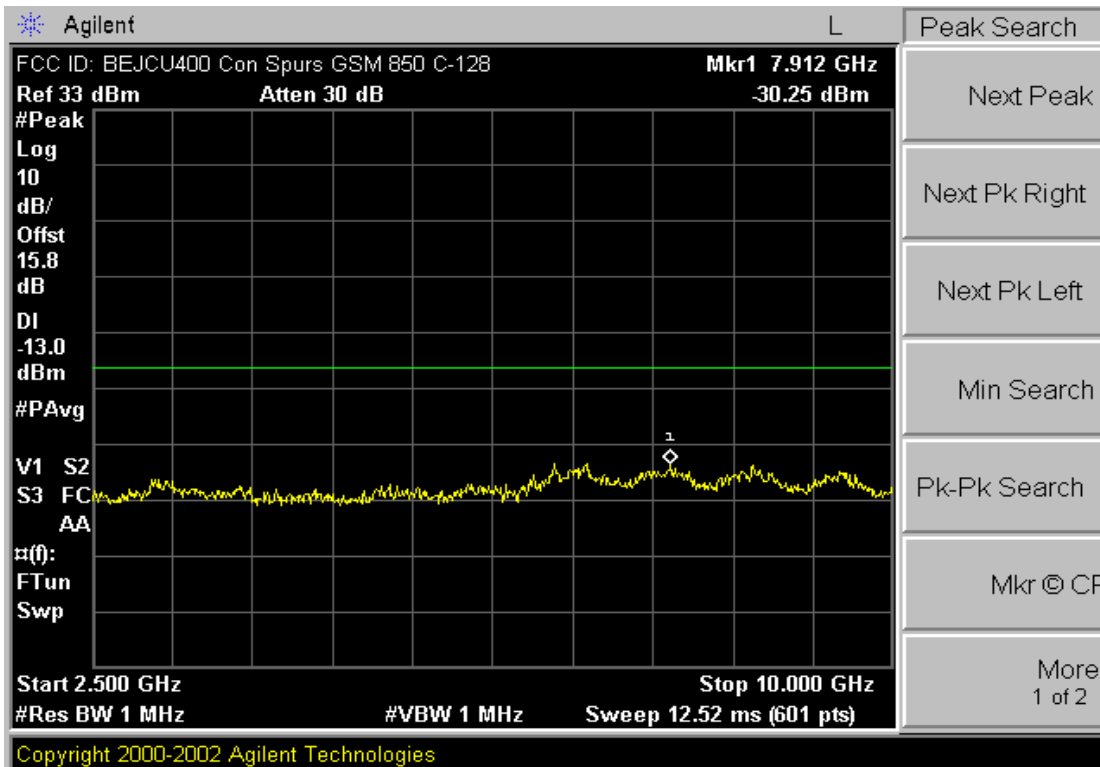

Plot A-2. Conducted Spurious Plot (Cellular GSM Mode – Ch. 128)

FCC ID: BEJCU400	 PCTEST	FCC Pt. 22/24 GSM/EDGE MODE CONDUCTED PLOTS	Reviewed by: Quality Manager
Test Report S/N: 0610110885	Test Dates: October 13-18, 2006	EUT Type: Dual-Band Dual-Mode GSM/WCDMA Phone with Bluetooth	Page 1 of 10

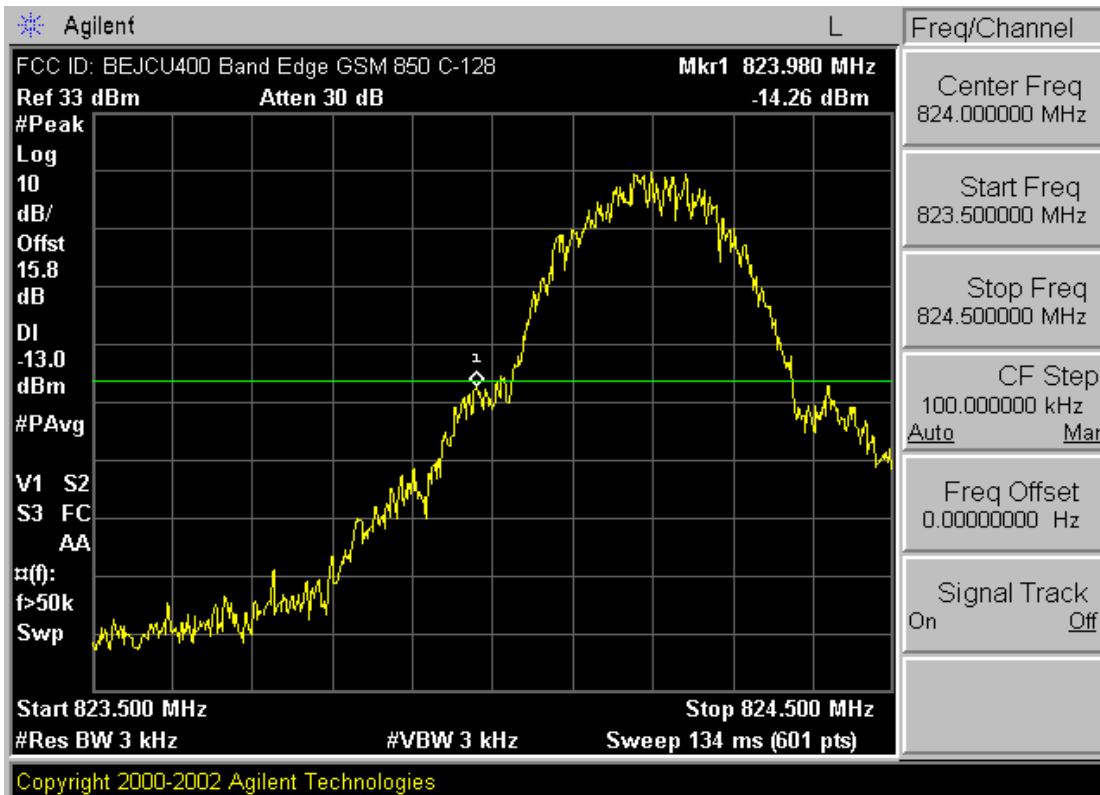

Plot A-3. Band Edge Plot (Cellular GSM Mode – Ch. 128)

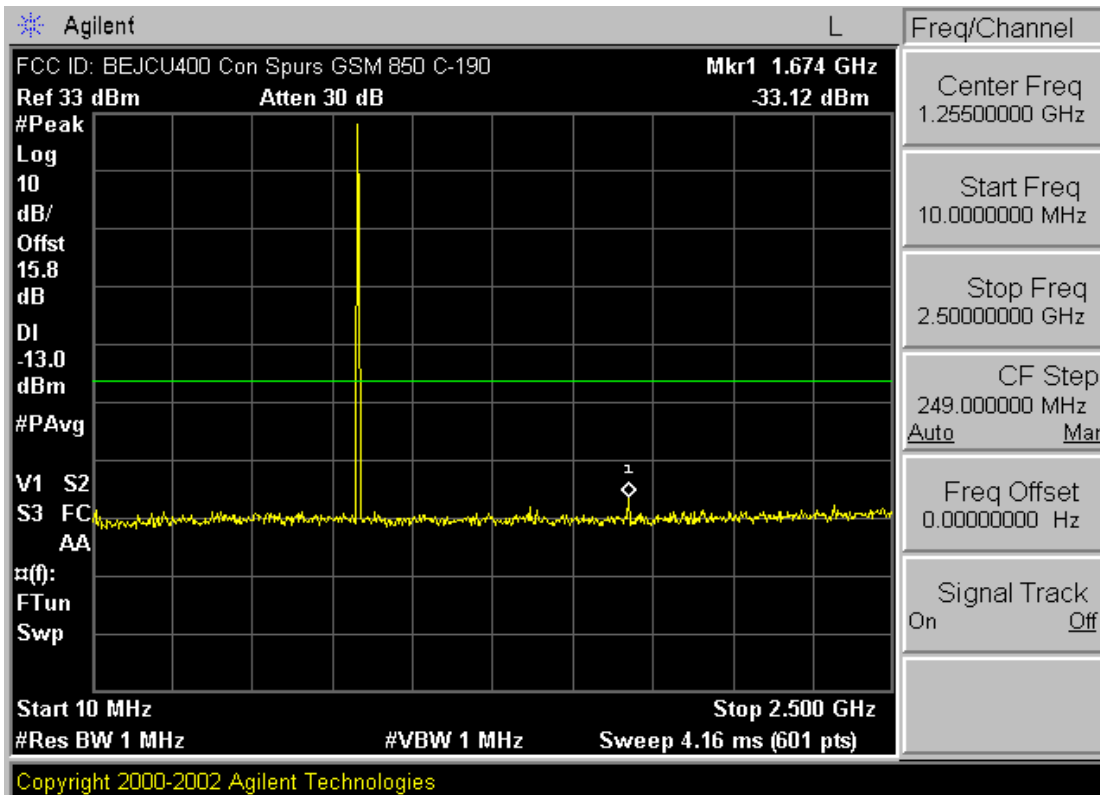

Plot A-4. Conducted Spurious (Cellular GSM Mode – Ch. 190)

FCC ID: BEJCU400	 PCTEST	FCC Pt. 22/24 GSM/EDGE MODE CONDUCTED PLOTS	Reviewed by: Quality Manager
Test Report S/N: 0610110885	Test Dates: October 13-18, 2006	EUT Type: Dual-Band Dual-Mode GSM/WCDMA Phone with Bluetooth	Page 2 of 10

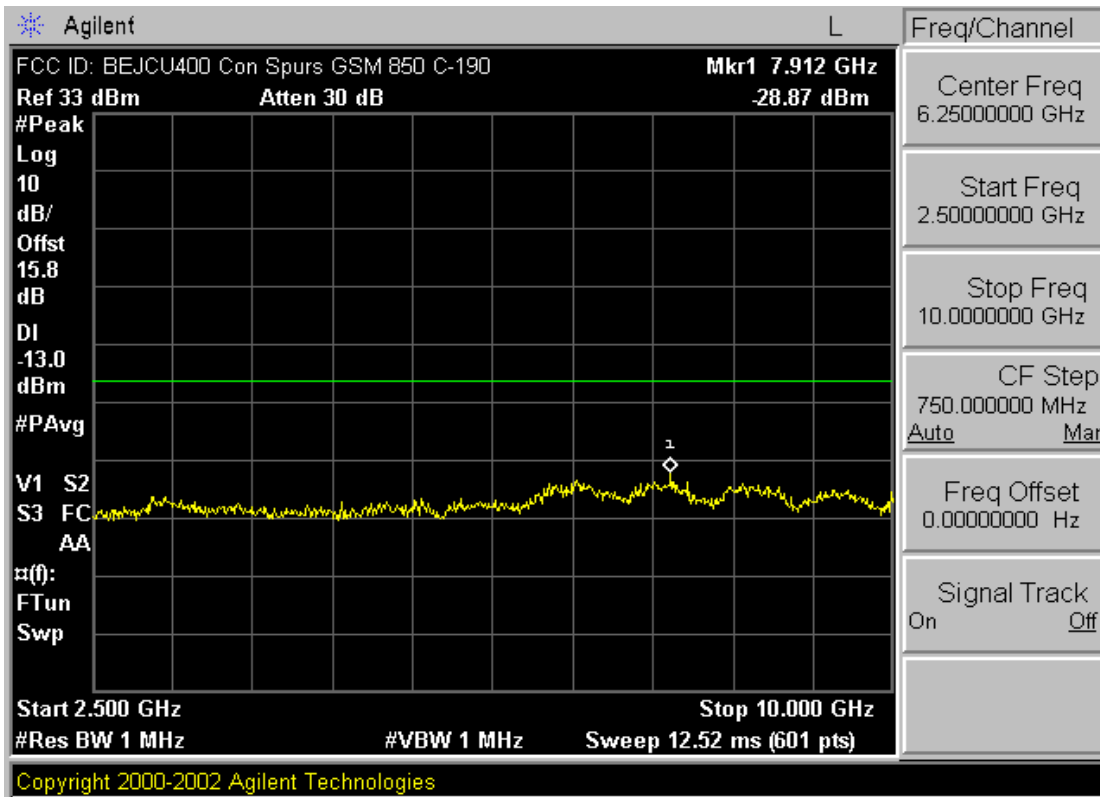

Plot A-5. Conducted Spurious Plot (Cellular GSM Mode – Ch. 190)

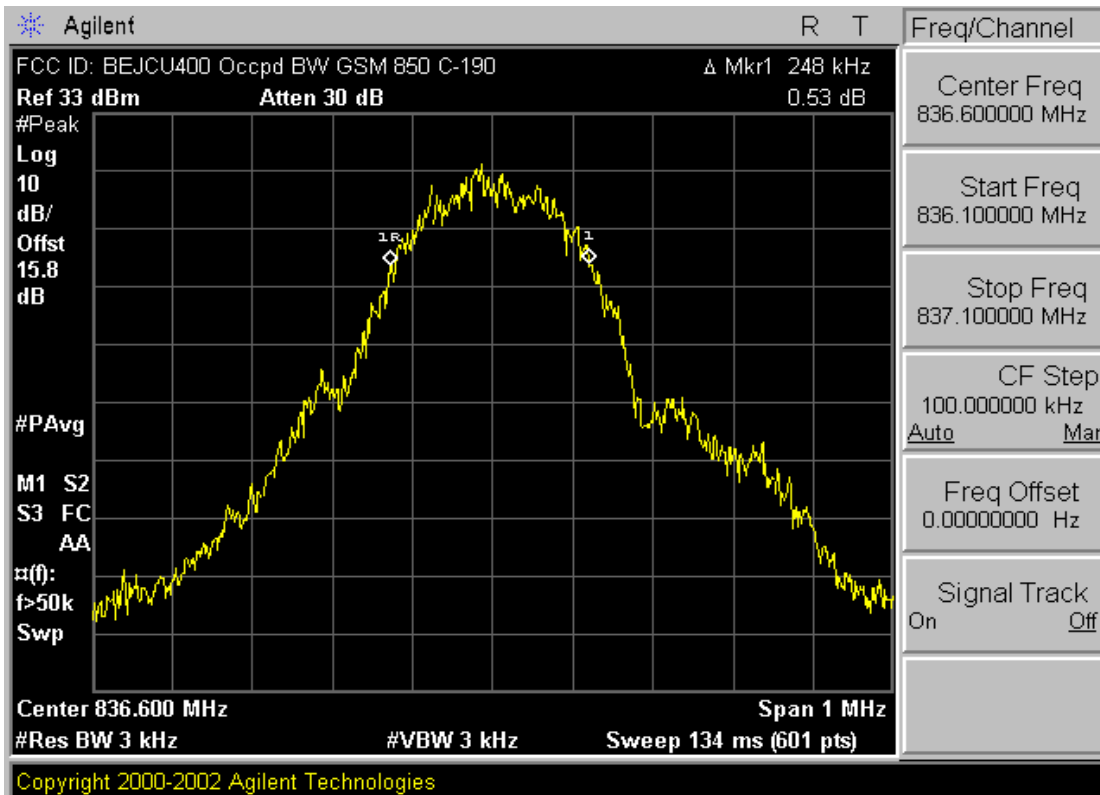

Plot A-6. Occupied Bandwidth Plot (Cellular GSM Mode – Ch. 190)

FCC ID: BEJCU400	 PCTEST	FCC Pt. 22/24 GSM/EDGE MODE CONDUCTED PLOTS	Reviewed by: Quality Manager
Test Report S/N: 0610110885	Test Dates: October 13-18, 2006	EUT Type: Dual-Band Dual-Mode GSM/WCDMA Phone with Bluetooth	Page 3 of 10

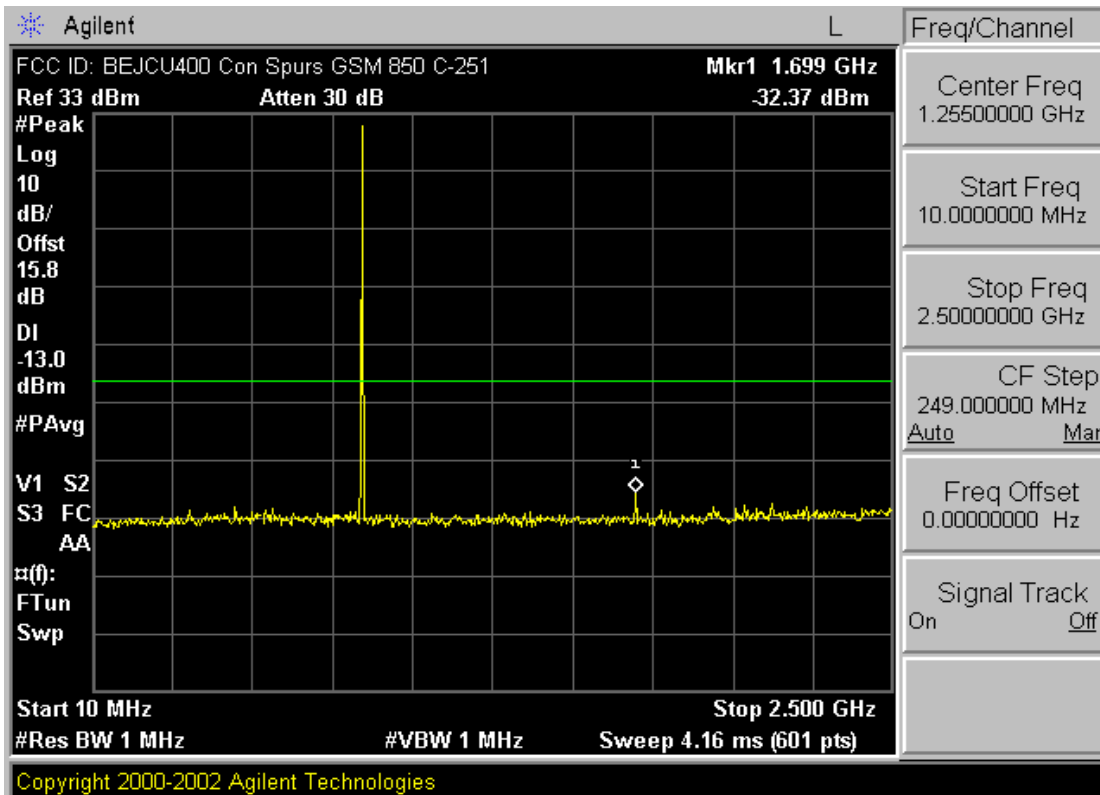

Plot A-7. Conducted Spurious Plot (Cellular GSM Mode – Ch. 251)

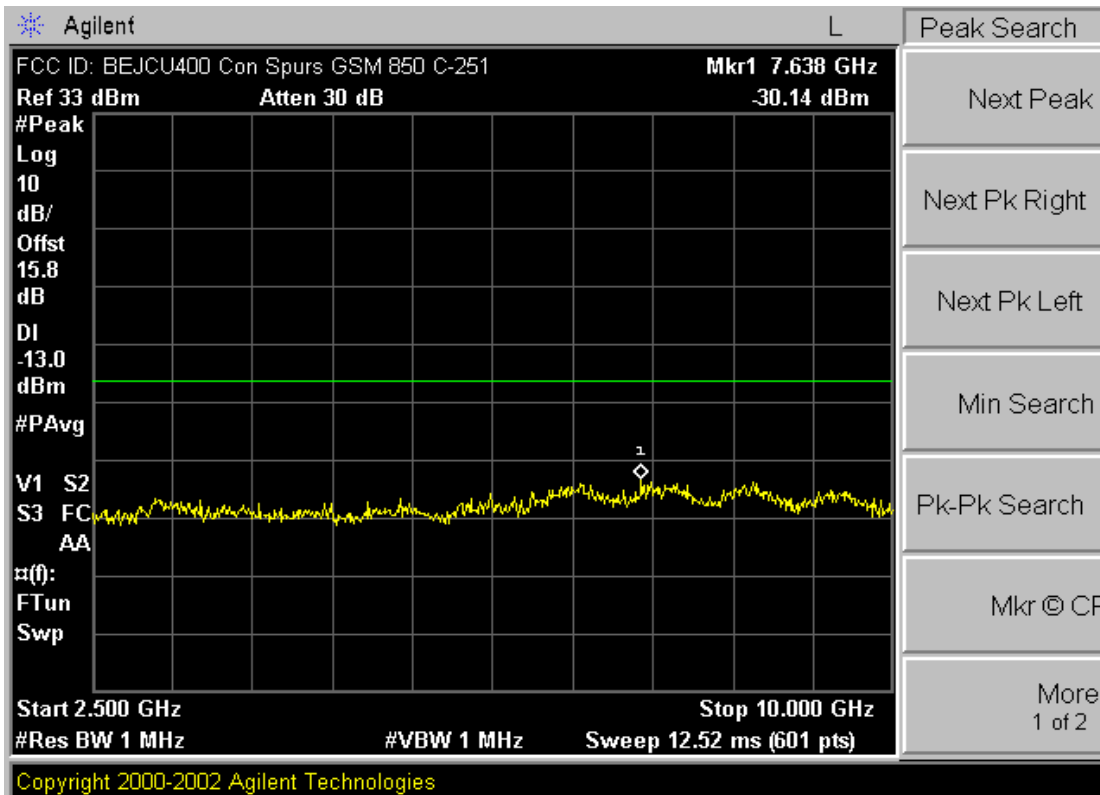

Plot A-8. Conducted Spurious Plot (Cellular GSM Mode – Ch. 251)

FCC ID: BEJCU400	 PCTEST	FCC Pt. 22/24 GSM/EDGE MODE CONDUCTED PLOTS	Reviewed by: Quality Manager
Test Report S/N: 0610110885	Test Dates: October 13-18, 2006	EUT Type: Dual-Band Dual-Mode GSM/WCDMA Phone with Bluetooth	Page 4 of 10

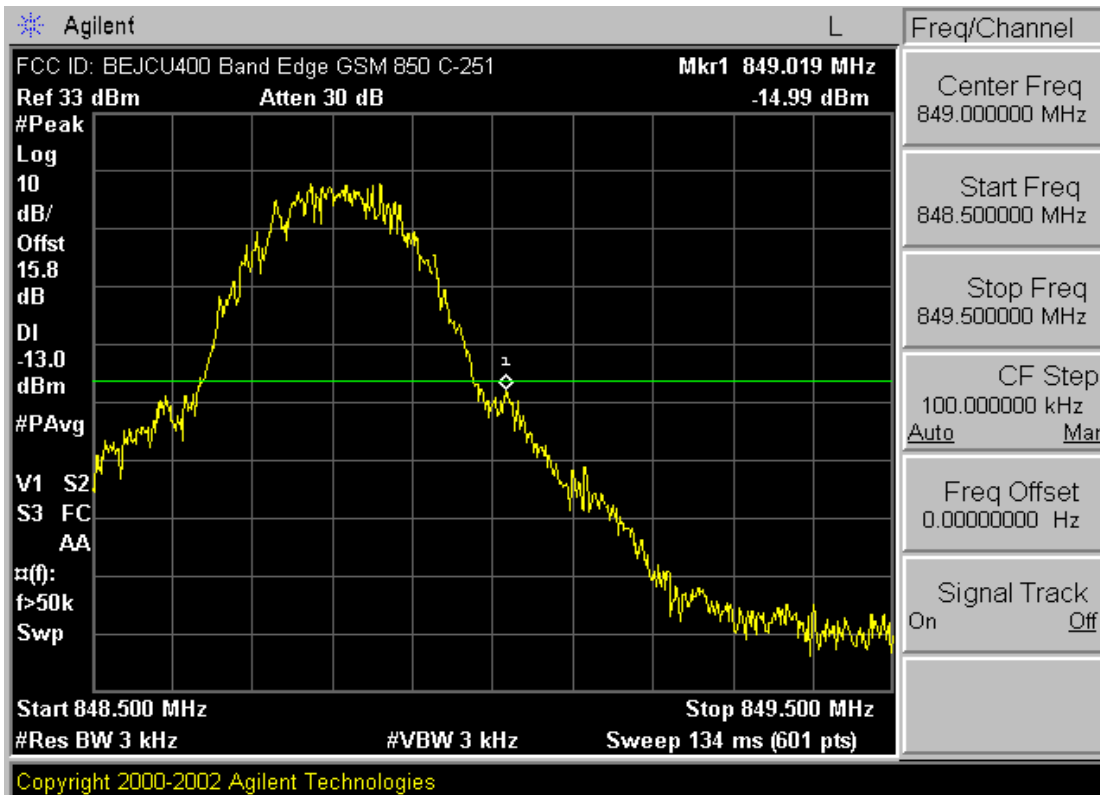

Plot A-9. Band Edge Plot (Cellular GSM Mode – Ch. 251)

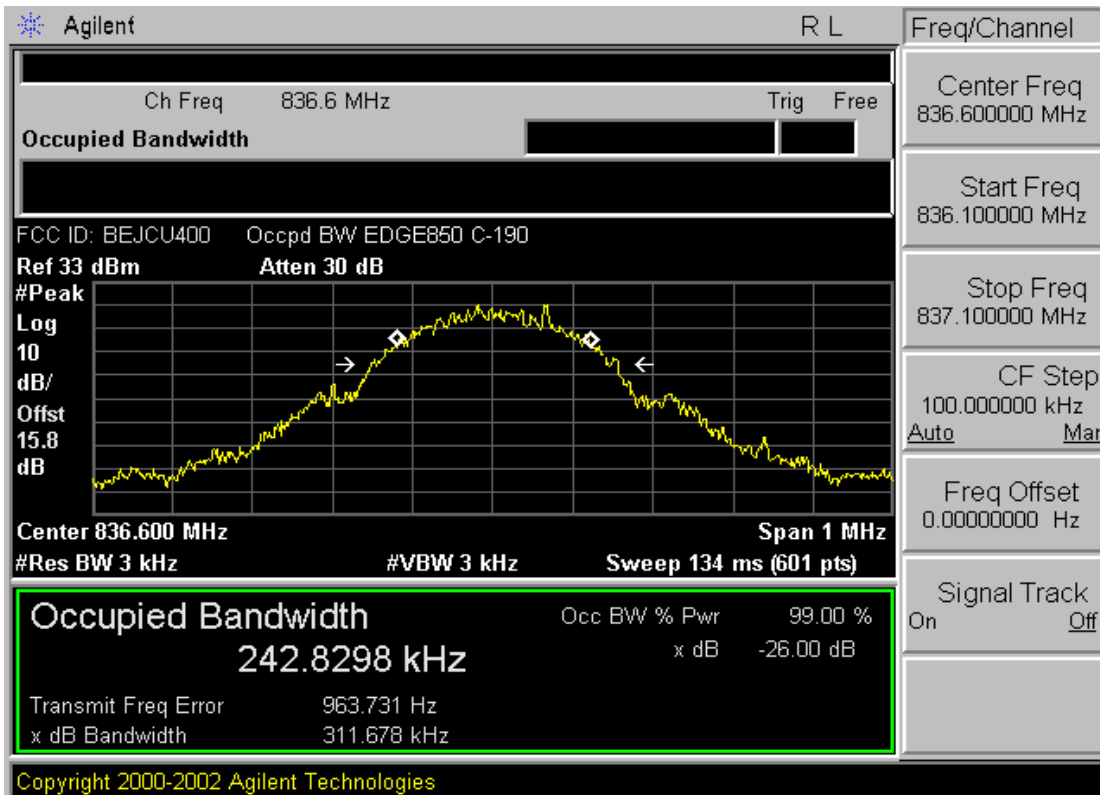

Plot A-10. Occupied Bandwidth Plot (EDGE850 Mode – Ch. 190)

FCC ID: BEJCU400	PCTEST	FCC Pt. 22/24 GSM/EDGE MODE CONDUCTED PLOTS	Reviewed by: Quality Manager
Test Report S/N: 0610110885	Test Dates: October 13-18, 2006	EUT Type: Dual-Band Dual-Mode GSM/WCDMA Phone with Bluetooth	Page 5 of 10

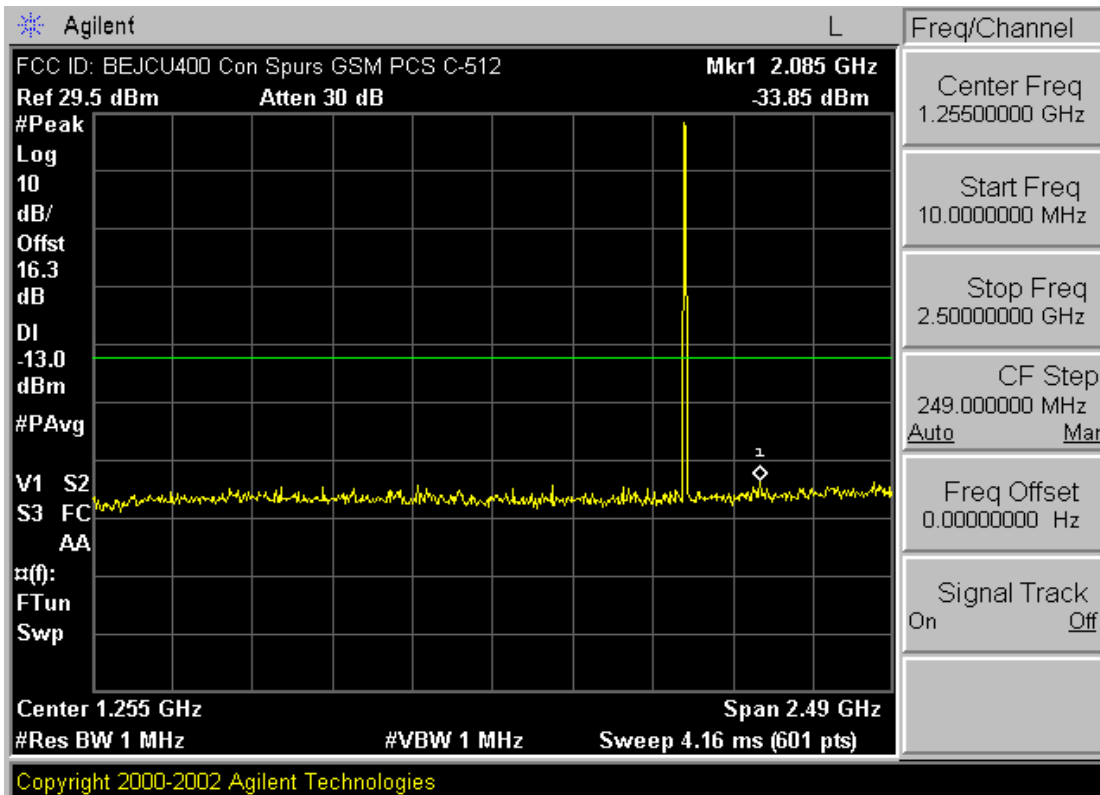

Plot A-11. Conducted Spurious Plot (PCS GSM Mode – Ch. 512)

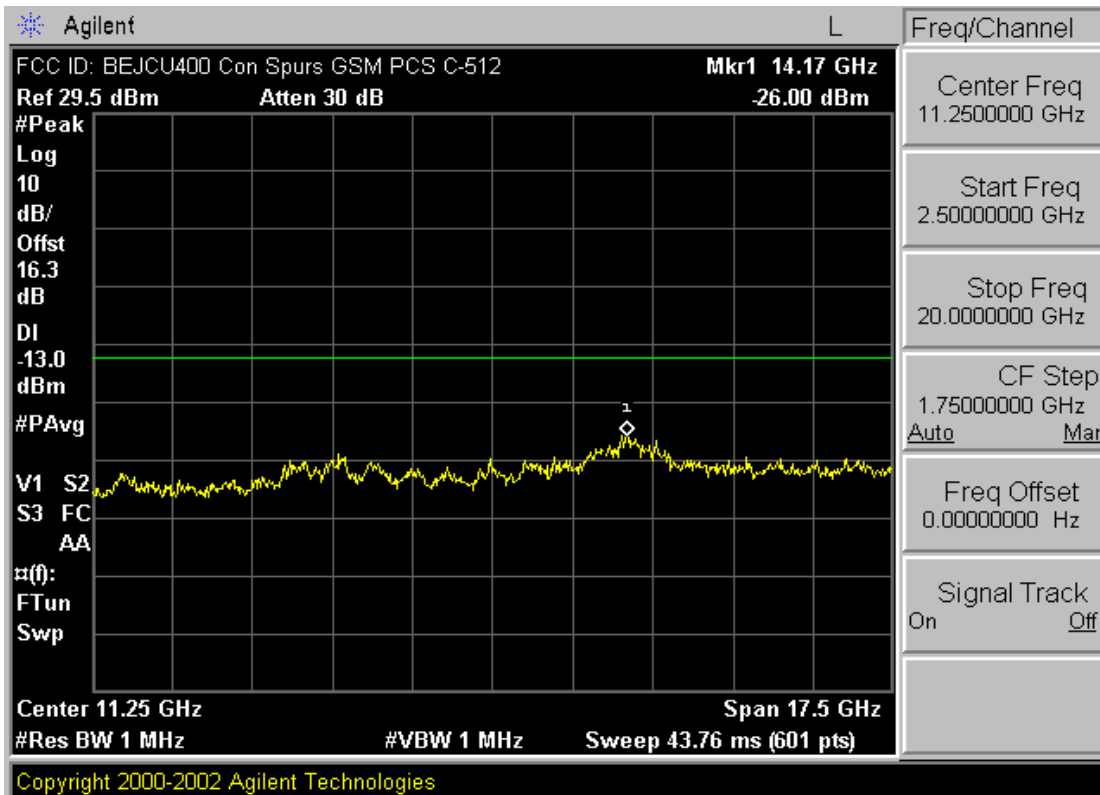

Plot A-12. Conducted Spurious Plot (PCS GSM Mode – Ch. 512)

FCC ID: BEJCU400	 PCTEST	FCC Pt. 22/24 GSM/EDGE MODE CONDUCTED PLOTS	Reviewed by: Quality Manager
Test Report S/N: 0610110885	Test Dates: October 13-18, 2006	EUT Type: Dual-Band Dual-Mode GSM/WCDMA Phone with Bluetooth	Page 6 of 10

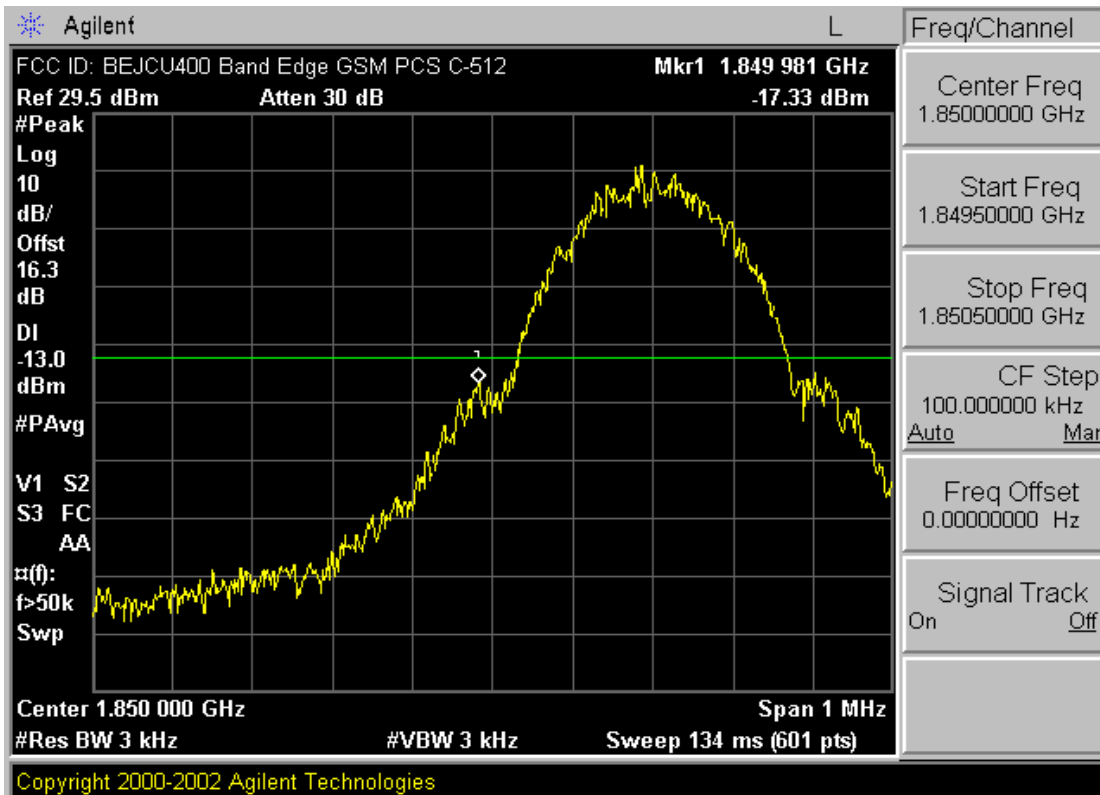

Plot A-13. Band Edge Plot (PCS GSM Mode – Ch. 512)

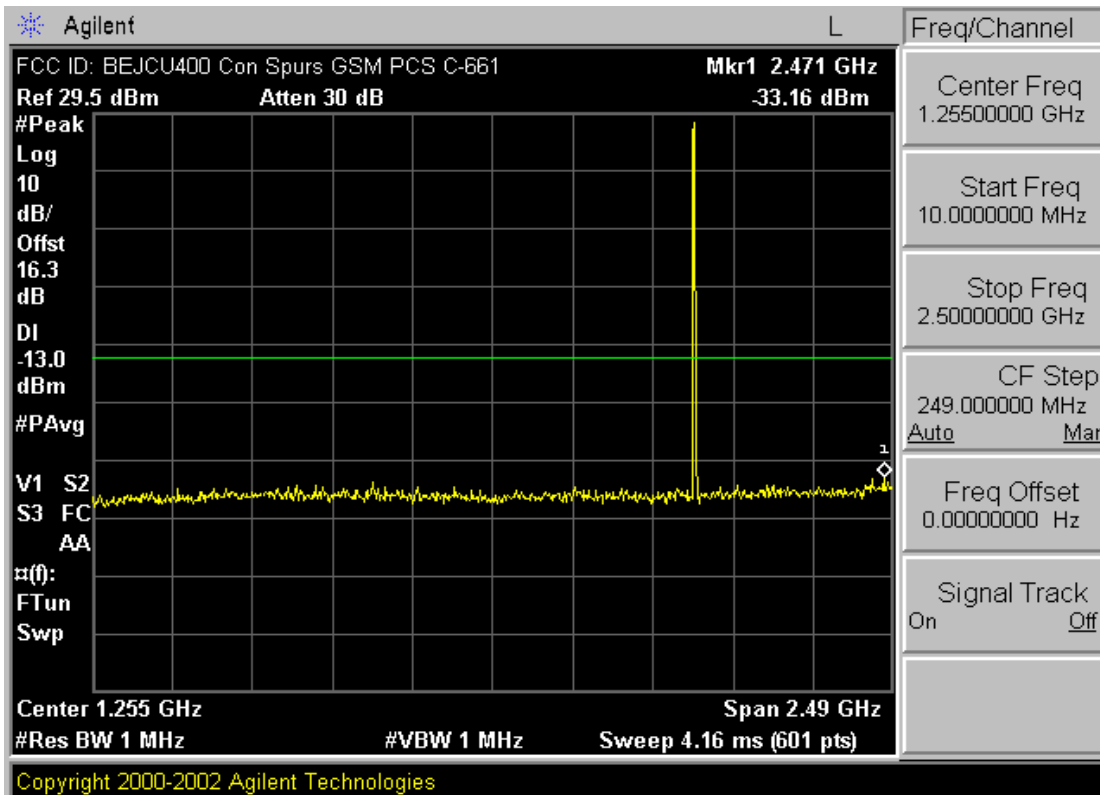

Plot A-14. Conducted Spurious Plot (PCS GSM Mode – Ch. 661)

FCC ID: BEJCU400	 PCTEST	FCC Pt. 22/24 GSM/EDGE MODE CONDUCTED PLOTS	Reviewed by: Quality Manager
Test Report S/N: 0610110885	Test Dates: October 13-18, 2006	EUT Type: Dual-Band Dual-Mode GSM/WCDMA Phone with Bluetooth	Page 7 of 10

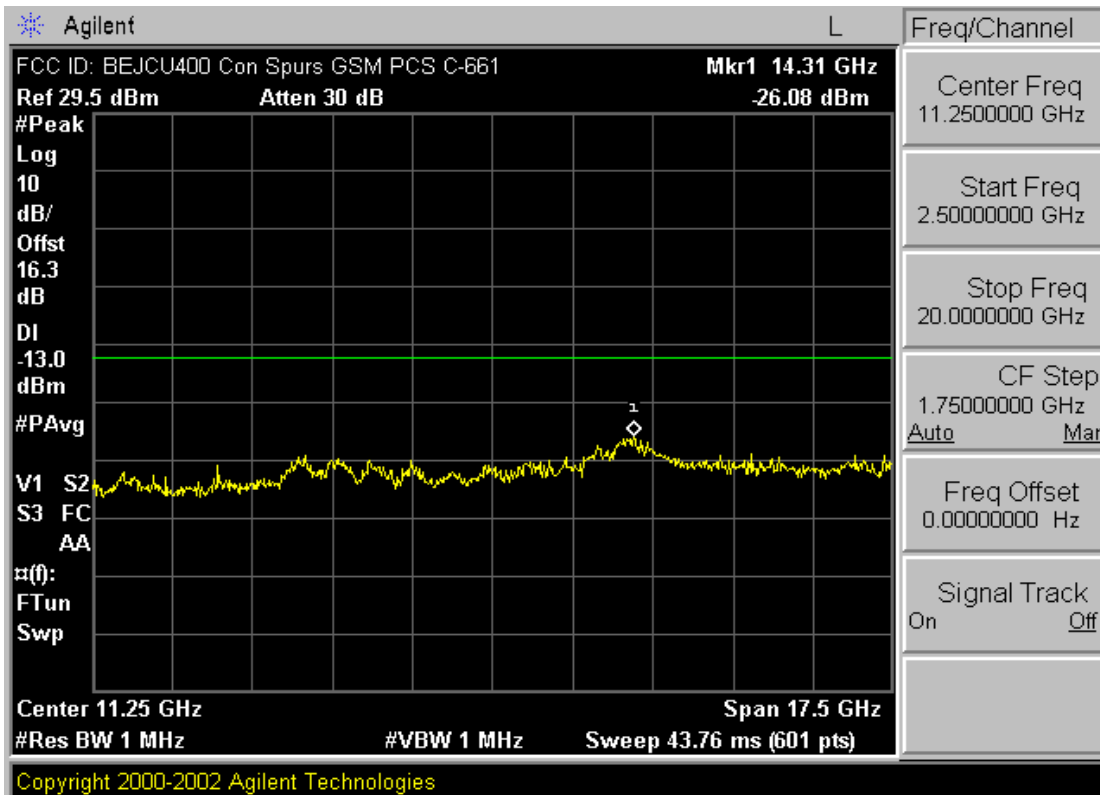

Plot A-15. Conducted Spurious Plot (PCS GSM Mode – Ch. 661)

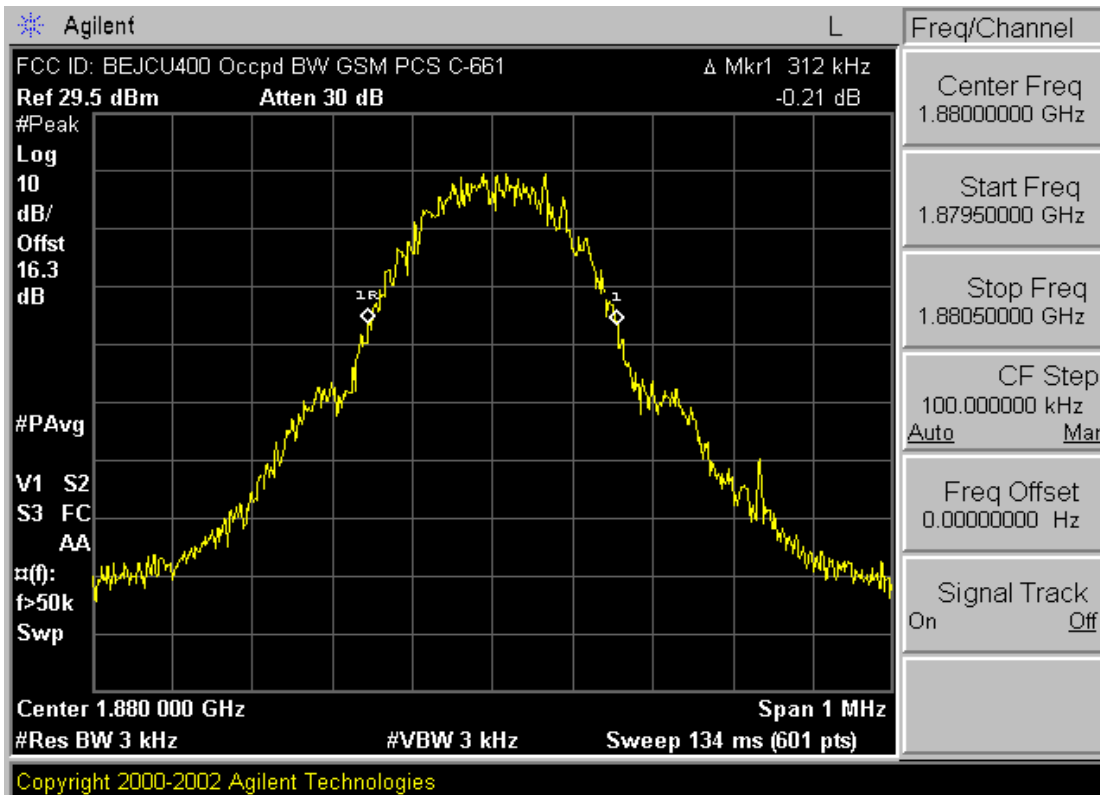

Plot A-16. Occupied Bandwidth Plot (PCS GSM Mode – Ch. 661)

FCC ID: BEJCU400	 PCTEST	FCC Pt. 22/24 GSM/EDGE MODE CONDUCTED PLOTS	Reviewed by: Quality Manager
Test Report S/N: 0610110885	Test Dates: October 13-18, 2006	EUT Type: Dual-Band Dual-Mode GSM/WCDMA Phone with Bluetooth	Page 8 of 10

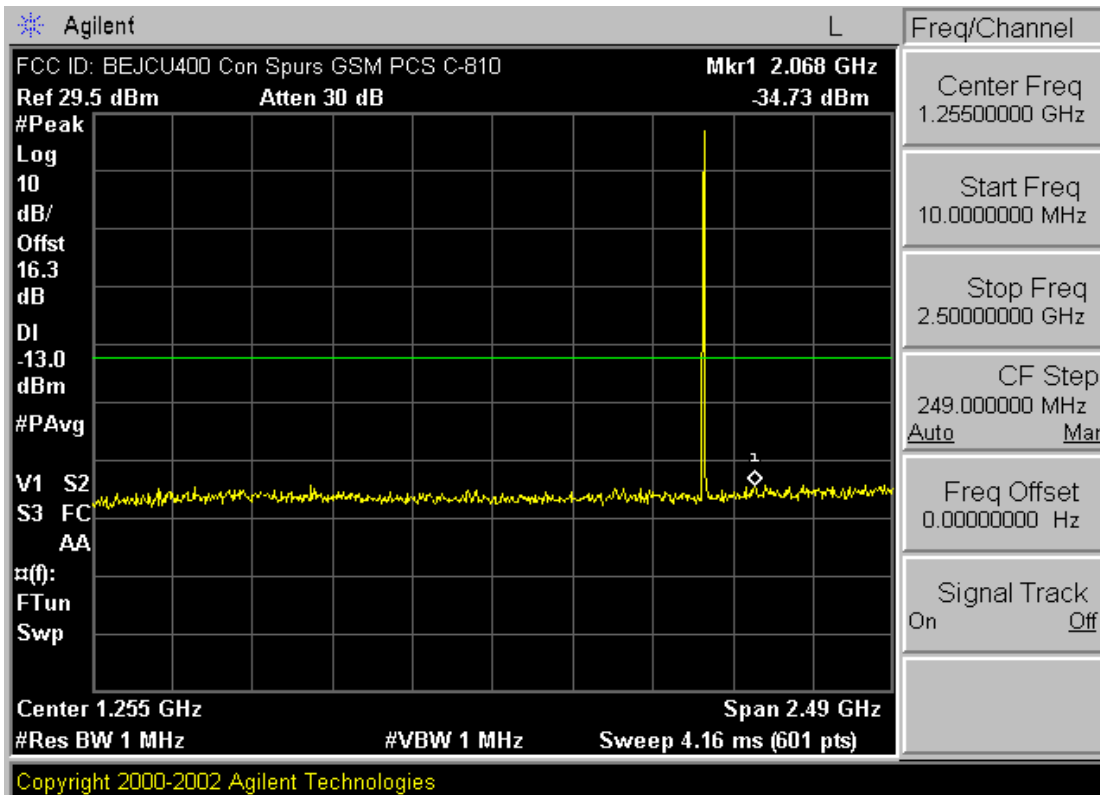

Plot A-17. Conducted Spurious Plot (PCS GSM Mode – Ch. 810)

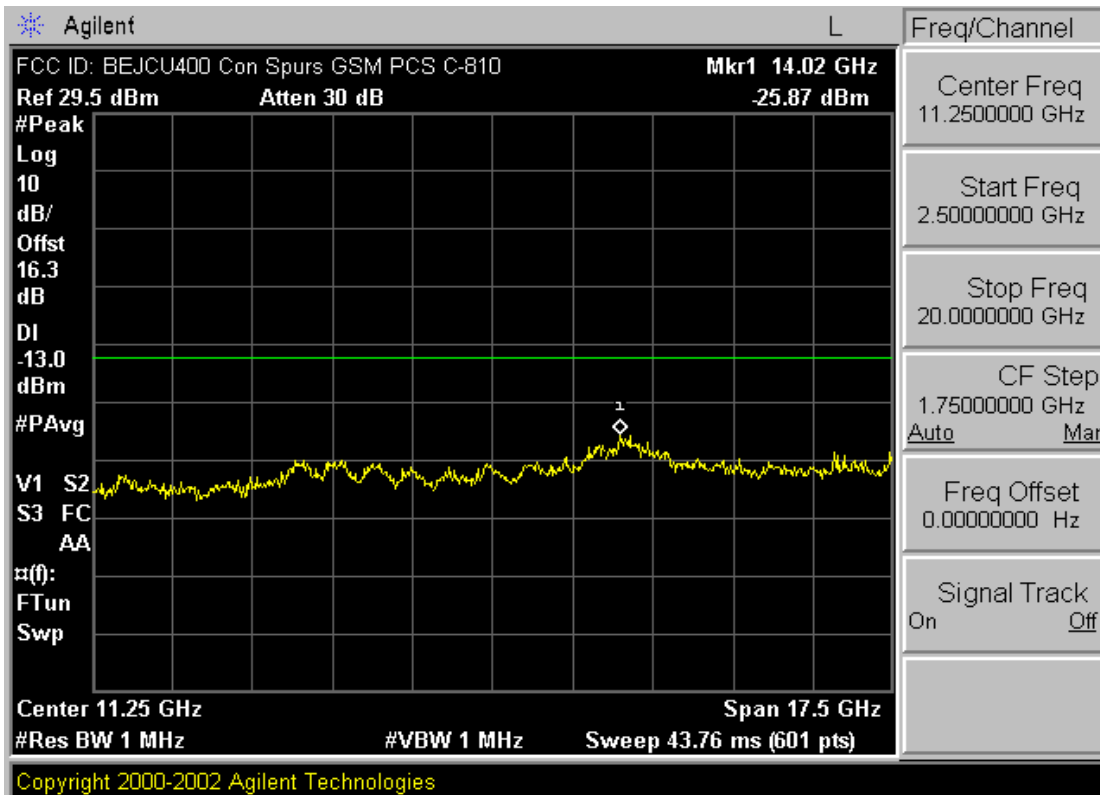

Plot A-18. Conducted Spurious Plot (PCS GSM Mode – Ch. 810)

FCC ID: BEJCU400	 PCTEST	FCC Pt. 22/24 GSM/EDGE MODE CONDUCTED PLOTS	Reviewed by: Quality Manager
Test Report S/N: 0610110885	Test Dates: October 13-18, 2006	EUT Type: Dual-Band Dual-Mode GSM/WCDMA Phone with Bluetooth	Page 9 of 10

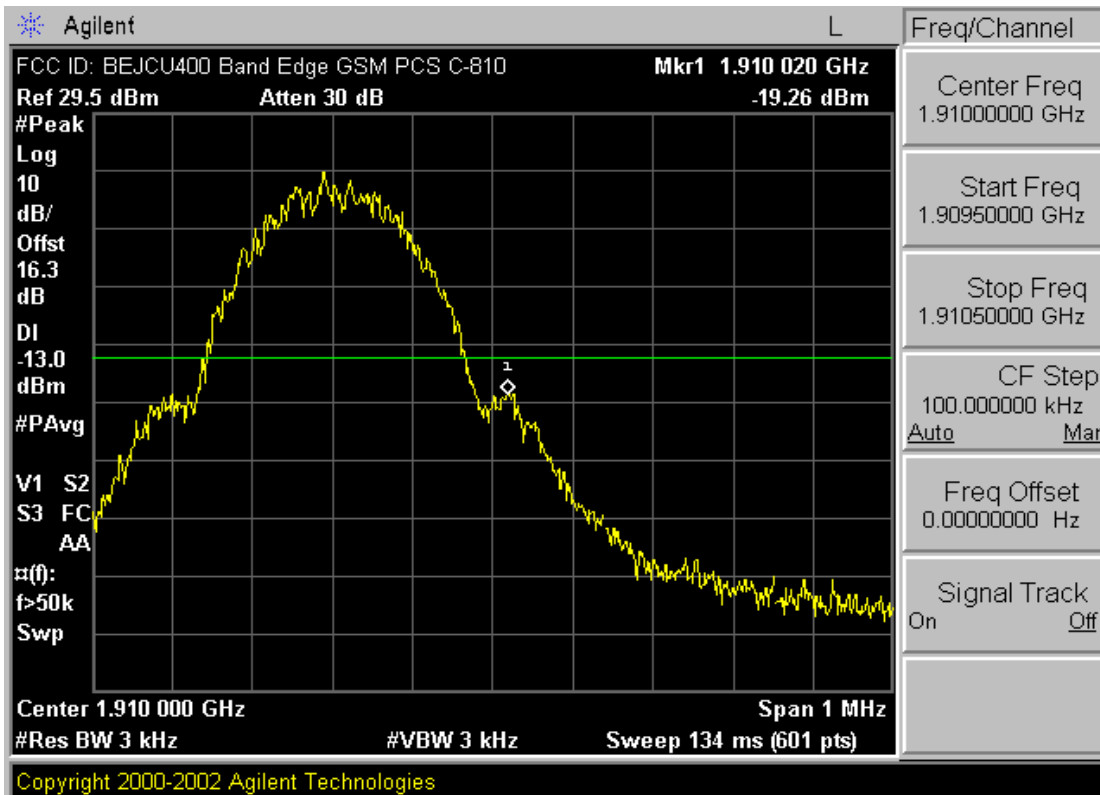

Plot A-19. Band Edge Plot (PCS GSM Mode – Ch. 810)

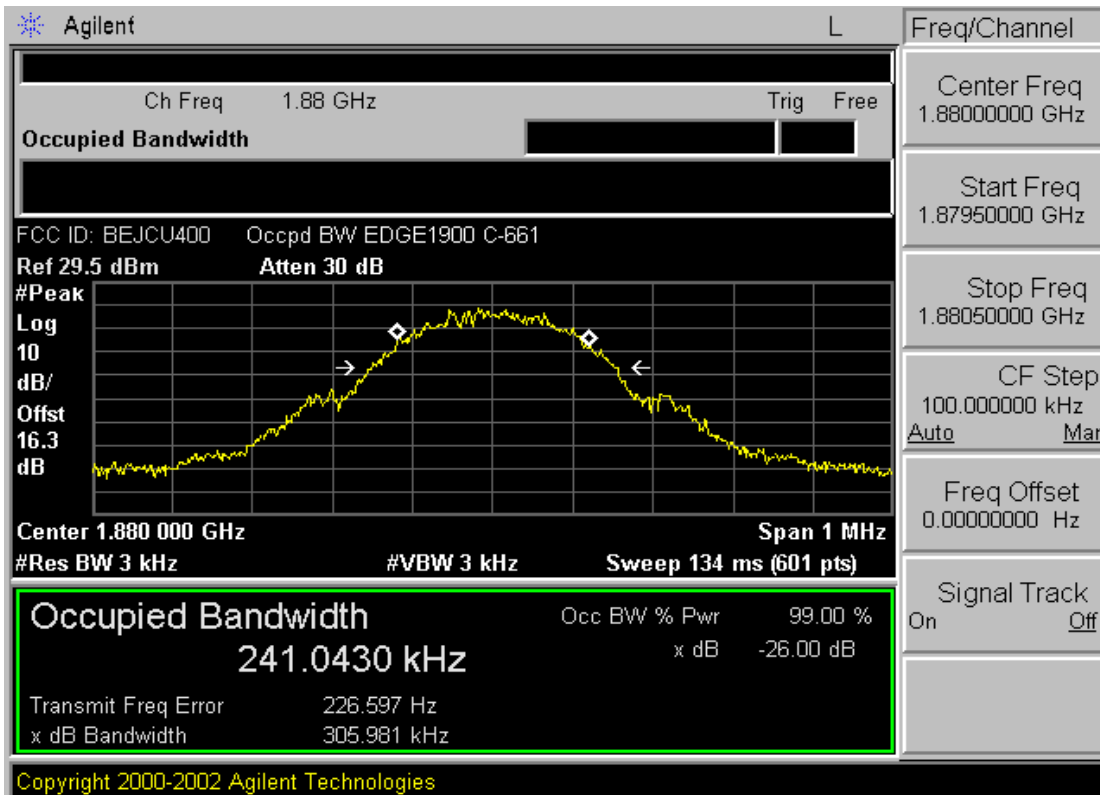

Plot A-20. Occupied Bandwidth Plot (EDGE1900 Mode – Ch. 810)

FCC ID: BEJCU400	PCTEST	FCC Pt. 22/24 GSM/EDGE MODE CONDUCTED PLOTS	Reviewed by: Quality Manager
Test Report S/N: 0610110885	Test Dates: October 13-18, 2006	EUT Type: Dual-Band Dual-Mode GSM/WCDMA Phone with Bluetooth	Page 10 of 10