





# SAR TEST REPORT

HCT CO., LTD

EUT Type:	Cellular/PCS WCDMA/GSM/EDGE Phone with WLAN, Bluetooth & FM Transmitter GPRS Class 12 and GPRS mode class B(GPRS and GSM, but not simultaneously)		
FCC ID:	BEJBL40F		
Model:	BL40f	Trade Name	LG
Date of Issue:	Jun.19, 2009		
Test report No.:	HCT-IA0906-0301		
Test Laboratory:	HCT CO., LTD. SAN 136-1, AMI-RI, BUBAL-EUP, ICHEON-SI, KYOUNGKI-DO, 467-701, KOREA TEL: +82 31 639 8565 FAX: +82 31 639 8525		
Applicant :	LG Electronics, Inc. 60-39, Gasan-Dong, Gumchon-Gu, Seoul 153-023, Korea Tel: +82-2-2033-1113 Fax: +82-2-2033-1222		
Testing has been carried out in accordance with:	47CFR §2.1093 FCC OET Bulletin 65(Edition 97-01), Supplement C (Edition 01-01) ANSI/ IEEE C95.1 – 2005 IEEE 1528-2003		
Test result:	The tested device complies with the requirements in respect of all parameters subject to the test. The test results and statements relate only to the items tested. The test report shall not be reproduced except in full, without written approval of the laboratory.		
Signature	 _____ Report prepared by : Sun-Hee Kim Test Engineer of SAR Part	 _____ Approved by : Jae-Sang So Manager of SAR Part	

# Table of Contents

<u>1. INTRODUCTION</u> .....	3
<u>2. DESCRIPTION OF DEVICE</u> .....	4
<u>3. DESCRIPTION OF TEST EQUIPMENT</u> .....	5
<u>3.1 SAR MEASUREMENT SETUP</u> .....	5
<u>3.2 DASY E-FIELD PROBE SYSTEM</u> .....	6
<u>3.3 PROBE CALIBRATION PROCESS</u> .....	7
<u>3.4 SAM Phantom</u> .....	9
<u>3.5 Device Holder for Transmitters</u> .....	9
<u>3.6 Brain &amp; Muscle Simulating Mixture Characterization</u> .....	10
<u>3.7 SAR TEST EQUIPMENT</u> .....	11
<u>4. SAR MEASUREMENT PROCEDURE</u> .....	12
<u>5. DESCRIPTION OF TEST POSITION</u> .....	13
<u>5.1 HEAD POSITION</u> .....	13
<u>5.2 Body Holster/Belt Clip Configurations</u> .....	14
<u>6. MEASUREMENT UNCERTAINTY</u> .....	15
<u>7. ANSI/ IEEE C95.1 - 2005 RF EXPOSURE LIMITS</u> .....	16
<u>8. SYSTEM VERIFICATION</u> .....	17
<u>8.1 Tissue Verification</u> .....	17
<u>8.2 System Validation</u> .....	17
<u>9. TEST CONFIGURATIONS</u> .....	18
<u>10. RF CONDUCTED POWER</u> .....	19
<u>10.1 Procedures Used to Establish RF Signal for SAR</u> .....	19
<u>11. SAR Evaluation Considerations for Handsets with Multiple Transmitters and Antennas</u> .....	21
<u>12. SAR TEST DATA SUMMARY</u> .....	22
<u>12.1 Measurement Results (GSM850 Head SAR Touch)</u> .....	22
<u>12.2 Measurement Results (GSM850 Head SAR Tilt)</u> .....	23
<u>12.3 Measurement Results (GSM1900 Head SAR Touch)</u> .....	24
<u>12.4 Measurement Results (GSM1900 Head SAR Tilt)</u> .....	25
<u>12.5 Measurement Results (WCDMA850 Head SAR Touch)</u> .....	26
<u>12.6 Measurement Results (WCDMA850 Head SAR Tilt)</u> .....	27
<u>12.7 Measurement Results (GSM850 Body SAR)</u> .....	28
<u>12.8 Measurement Results (GSM1900 Body SAR)</u> .....	29
<u>12.9 Measurement Results (WCDMA850 Body SAR)</u> .....	30
<u>12.10 Measurement Results (802.11b/g Module Body SAR)</u> .....	31
<u>13. CONCLUSION</u> .....	32
<u>14. REFERENCES</u> .....	33
Attachment 1. – SAR Test Plots .....	34
Attachment 2. – Dipole Validation Plots .....	71
Attachment 3. – Probe Calibration Data .....	82
Attachment 4. – Dipole Calibration Data .....	92

# 1. INTRODUCTION

The FCC has adopted the guidelines for evaluating the environmental effects of radio frequency radiation in ET Docket 93-62 on Aug. 6, 1996 to protect the public and workers from the potential hazards of RF emissions due to FCC-regulated portable devices.

The safety limits used for the environmental evaluation measurements are based on the criteria published by the American National Standards Institute (ANSI) for localized specific absorption rate (SAR) in IEEE/ANSI C95.1-2005 Standard for Safety Levels with Respect to Human Exposure to Radio Frequency Electromagnetic Fields, 3 kHz to 300 GHz. 1992 by the Institute of Electrical and Electronics Engineers, Inc., New York, New York 10017. The measurement procedure described in IEEE/ANSI C95.3-1992 Recommended Practice for the Measurement of Potentially Hazardous Electromagnetic Fields - RF and Microwave is used for guidance in measuring SAR due to the RF radiation exposure from the Equipment Under Test (EUT). These criteria for SAR evaluation are similar to those recommended by the National Council on Radiation Protection and Measurements (NCRP) in Biological Effects and Exposure Criteria for Radio frequency Electromagnetic Fields," NCRP Report No. 86 NCRP, 1986, Bethesda, MD 20814. SAR is a measure of the rate of energy absorption due to exposure to an RF transmitting source. SAR values have been related to threshold levels for potential biological hazards.

## SAR Definition

Specific Absorption Rate (SAR) is defined as the time derivative of the incremental electromagnetic energy (dW) absorbed by (dissipated in) an incremental mass (dm) contained in a volume element (dV) of a given density (r). It is also defined as the rate of RF energy absorption per unit mass at a point in an absorbing body.

$$SAR = \frac{d}{dt} \left( \frac{dU}{dm} \right) = \frac{d}{dt} \left( \frac{dU}{\rho dV} \right)$$

**Figure 2. SAR Mathematical Equation**

**SAR is expressed in units of Watts per Kilogram (W/kg).**

$$SAR = \sigma E^2 / \rho$$

where:

- $\sigma$  = conductivity of the tissue-simulant material (S/m)
- $\rho$  = mass density of the tissue-simulant material (kg/m<sup>3</sup>)
- $E$  = Total RMS electric field strength (V/m)

NOTE: The primary factors that control rate of energy absorption were found to be the wavelength of the incident field in relations to the dimensions and geometry of the irradiated organism, the orientation of the organism in relation to the polarity of field vectors, the presence of reflecting surfaces, and whether conductive contact is made by the organism with a ground plane.

## 2. DESCRIPTION OF DEVICE

Environmental evaluation measurements of specific absorption rate (SAR) distributions in emulated human head and body tissues exposed to radio frequency (RF) radiation from wireless portable devices for compliance with the rules and regulations of the U.S. Federal Communications Commission (FCC).

EUT Type	Cellular/PCS WCDMA/GSM/EDGE Phone with WLAN, Bluetooth & FM Transmitter GPRS Class 12 and GPRS mode class B(GPRS and GSM, but not simultaneously)
FCC ID	BEJBL40F
Model(s)	BL40f
Trade Name	LG
Serial Number(s)	#1
Application Type	Certification
Modulation(s)	GSM850/GSM1900/WCDMA850
Tx Frequency	824.20 - 848.80 MHz (GSM850) 826.4~846.6 MHz (WCDMA850) 1850.20 - 1909.80 MHz (GSM1900) 2 412- 2 462 MHz (DSSS/ OFDM)
Rx Frequency	869.20 - 893.80 MHz (GSM850) 871.4 - 891.6 (WCDMA850) 1930.20 - 1989.80 MHz (GSM1900) 2 412- 2 462 MHz (DSSS/ OFDM)
FCC Classification	Licensed Portable Transmitter Held to Ear (PCE)
Production Unit or Identical Prototype	Prototype
Max SAR	0.417 W/kg GSM850 Head SAR / 1.08 W/kg GSM850 Body SAR 0.191 W/kg GSM1900 Head SAR / 0.744 W/kg GSM1900 Body SAR 0.378 W/kg WCDMA850 Head SAR / 0.686 W/kg WCDMA850 Body SAR 0.043 W/kg Wi-Fi 802.11b
Date(s) of Tests	Jun. 17, 2009 ~ Jun. 18, 2009 / Jul. 31, 2009
Antenna Type	Intenna

### 3. DESCRIPTION OF TEST EQUIPMENT

#### 3.1 SAR MEASUREMENT SETUP

These measurements are performed using the DASY4 automated dosimetric assessment system. It is made by Schmid & Partner Engineering AG (SPEAG) in Zurich, Switzerland. It consists of high precision robotics system (Staubli), robot controller, Pentium III computer, near-field probe, probe alignment sensor, and the generic twin phantom containing the brain equivalent material. The robot is a six-axis industrial robot performing precise movements to position the probe to the location (points) of maximum electromagnetic field (EMF) (see Figure.3.1).

A cell controller system contains the power supply, robot controller, teach pendant (Joystick), and remote control, is used to drive the robot motors. The PC consists of the HP Pentium IV 3.0 GHz computer with Windows XP system and SAR Measurement Software DASY4, A/D interface card, monitor, mouse, and keyboard. The Staubli Robot is connected to the cell controller to allow software manipulation of the robot. A data acquisition electronic (DAE) circuit performs the signal amplification, signal multiplexing, AD-conversion, offset measurements, mechanical surface detection, collision detection, etc. is connected to the Electro-optical coupler (EOC). The EOC performs the conversion from the optical into digital electric signal of the DAE and transfers data to the PC plug-in card.

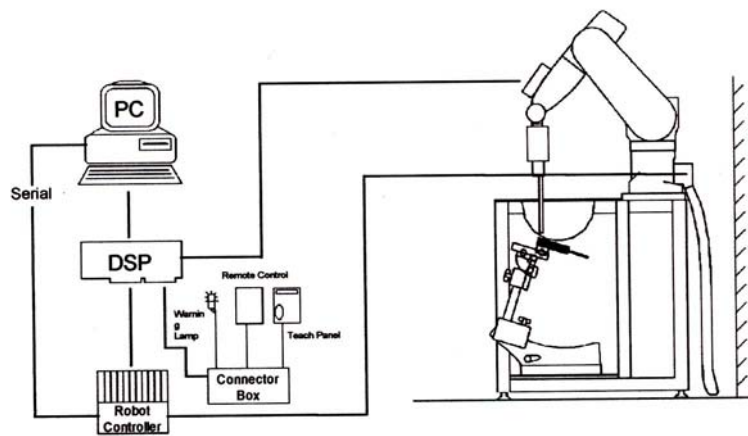

Figure 3.1 HCT SAR Lab. Test Measurement Set-up

The DAE4 consists of a highly sensitive electrometer-grade preamplifier with auto-zeroing, a channel and gain-switching multiplexer, a fast 16 bit AD-converter and a command decoder and control logic unit. Transmission to the PC-card is accomplished through an optical downlink for data and status information and an optical uplink for commands and clock lines. The mechanical probe mounting device includes two different sensor systems for frontal and sidewise probe contacts. They are also used for mechanical surface detection and probe collision detection. The robot uses its own controller with a built in VME-bus computer. The system is described in detail in.

## **3.2 DASY E-FIELD PROBE SYSTEM**

### **3.2.1 ET3DV6 Probe Specification**

Construction	Symmetrical design with triangular core Built-in optical fiber for surface detection System Built-in shielding against static charges
Calibration	In air from 10 MHz to 2.5 GHz In brain and muscle simulating tissue at Frequencies of 450 MHz, 900 MHz and 1.8 GHz (accuracy: 8 %)
Frequency	10 MHz to > 6 GHz; Linearity: $\pm 0.2$ dB (30 MHz to 3 GHz)
Directivity	$\pm 0.2$ dB in brain tissue (rotation around probe axis) $\pm 0.4$ dB in brain tissue (rotation normal probe axis)
Dynamic	5 $\mu$ W/g to > 100 mW/g;
Range Linearity:	$\pm 0.2$ dB
Surface Detection	$\pm 0.2$ mm repeatability in air and clear liquids over diffuse reflecting surfaces.
Dimensions	Overall length: 330 mm Tip length: 16 mm Body diameter: 12 mm Tip diameter: 6.8 mm Distance from probe tip to dipole centers: 2.7 mm
Application	General dissymmetry up to 3 GHz Compliance tests of mobile phones  Fast automatic scanning in arbitrary phantoms



Figure 3.2 Photograph of the probe and the Phantom



Figure 3.3 ET3DV6 E-field Probe

The SAR measurements were conducted with the dosimetric probe ET3DV6, designed in the classical triangular configuration and optimized for dosimetric evaluation. The probe is constructed using the thick film technique; with printed resistive lines on ceramic substrates. The probe is equipped with an optical multifiber line ending at the front of the probe tip. It is connected to the EOC box on the robot arm and provides an automatic detection of the phantom surface. Half of the fibers are connected to a pulsed infrared transmitter, the other half to a synchronized receiver. As the probe approaches the surface, the reflection from the surface produces a coupling from the transmitting to the receiving fibers. This reflection increases first during the approach, reaches a maximum and then decreases. If the probe is flatly touching the surface, the coupling is zero. The distance of the coupling maximum to the surface is independent of the surface reflectivity and largely independent of the surface to probe angle. The DASY4 software reads the reflection during a software approach and looks for the maximum using a 2<sup>nd</sup> order fitting. The approach is stopped at reaching the maximum.

### 3.3 PROBE CALIBRATION PROCESS

#### 3.3.1 E-Probe Calibration

Each probe is calibrated according to a dosimetric assessment procedure with an accuracy better than ± 10 %. The spherical isotropy was evaluated with the proper procedure and found to be better than ± 0.25 dB. The sensitivity parameters (NormX, NormY, NormZ), the diode compression parameter (DCP) and the conversion factor (ConvF) of the probe is tested.

The free space E-field from amplified probe outputs is determined in a test chamber. This is performed in a TEM cell for frequencies bellow 1 GHz, and in a waveguide above 1 GHz for free space. For the free space calibration, the probe is placed in the volumetric center of the cavity and at the proper orientation with the field. The probe is then rotated 360 degrees.

E-field temperature correlation calibration is performed in a flat phantom filled with the appropriate simulated brain tissue. The measured free space E-field in the medium correlates to temperature rise in a dielectric medium. For temperature correlation calibration a RF transparent thermistor-based temperature probe is used in conjunction with the E-field probe.

$$SAR = C \frac{\Delta T}{\Delta t}$$

where:

- $\Delta t$  = exposure time (30 seconds),
- C = heat capacity of tissue (brain or muscle),
- $\Delta T$  = temperature increase due to RF exposure.

SAR is proportional to  $\Delta T / \Delta t$ , the initial rate of tissue heating, before thermal diffusion takes place. Now it's possible to quantify the electric field in the simulated tissue by equating the thermally derived SAR to the E- field;

$$SAR = \frac{|E|^2 \cdot \sigma}{\rho}$$

where:

- $\sigma$  = simulated tissue conductivity,
- $\rho$  = Tissue density (1.25 g/cm<sup>3</sup> for brain tissue)

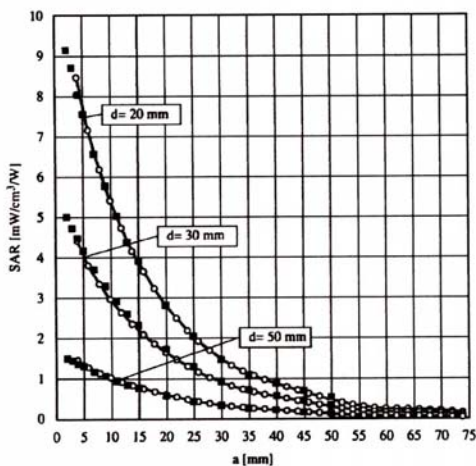

Figure 3.4 E-Field and Temperature measurements at 900 MHz

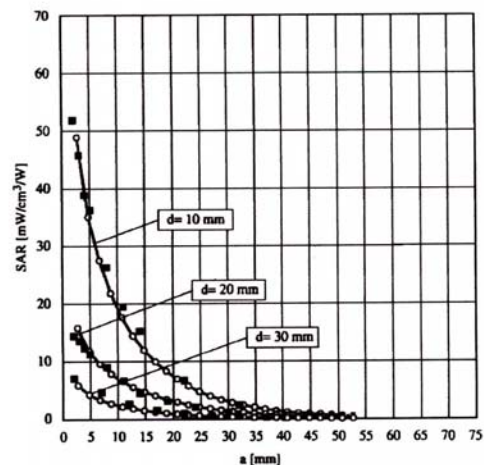

Figure 3.5 E-Field and temperature measurements at 1.8 GHz

### 3.3.2 Data Extrapolation

The DASY4 software automatically executes the following procedures to calculate the field units from the microvolt readings at the probe connector. The first step of the evaluation is a linearization of the filtered input signal to account for the compression characteristics of the detector diode. The compensation depends on the input signal, the diode type and the DC-transmission factor from the diode to the evaluation electronics. If the exciting field is pulsed, the crest factor of the signal must be known to correctly compensate for peak power. The formula for each channel can be given like below;

$$V_i = U_i + U_i^2 \cdot \frac{cf}{dcp_i}$$

with  $V_i$  = compensated signal of channel i (i=x,y,z)  
 $U_i$  = input signal of channel i (i=x,y,z)  
 $cf$  = crest factor of exciting field (DASY parameter)  
 $dcp_i$  = diode compression point (DASY parameter)

From the compensated input signals the primary field data for each channel can be evaluated:

E-field probes:

$$E_i = \sqrt{\frac{V_i}{Norm_i \cdot ConvF}}$$

with  $V_i$  = compensated signal of channel i (i = x,y,z)  
 $Norm_i$  = sensor sensitivity of channel i (i = x,y,z)  
 $\mu V/(V/m)^2$  for E-field probes  
 $ConvF$  = sensitivity of enhancement in solution  
 $E_i$  = electric field strength of channel i in V/m

The RSS value of the field components gives the total field strength (Hermetian magnitude):

$$E_{tot} = \sqrt{E_x^2 + E_y^2 + E_z^2}$$

The primary field data are used to calculate the derived field units.

$$SAR = E_{tot}^2 \cdot \frac{\sigma}{\rho \cdot 1000}$$

with  $SAR$  = local specific absorption rate in W/g  
 $E_{tot}$  = total field strength in V/m  
 $\sigma$  = conductivity in [mho/m] or [Siemens/m]  
 $\rho$  = equivalent tissue density in g/cm<sup>3</sup>

The power flow density is calculated assuming the excitation field to be a free space field.

$$P_{pwe} = \frac{E_{tot}^2}{3770}$$

with  $P_{pwe}$  = equivalent power density of a plane wave in W/cm<sup>2</sup>  
 $E_{tot}$  = total electric field strength in V/m

### 3.4 SAM Phantom

The SAM Phantom is constructed of a fiberglass shell integrated in a wooden table. The shape of the shell is based on data from an anatomical study designed to determine the maximum exposure in at least 90 % of all users. It enables the dosimetric evaluation of left and right hand phone usage as well as body mounted usage at the flat phantom region. A cover prevents the evaporation of the liquid. Reference markings on the Phantom allow the complete setup of all predefined phantom positions and measurement grids by manually teaching three points in the robot.

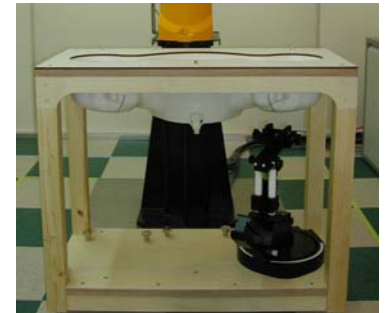

Figure 3.6 SAM Phantom

Shell Thickness	2.0 mm
Filling Volume	about 30 L
Dimensions	810 mm x 1 000 mm x 500 mm (H x L x W)

### 3.5 Device Holder for Transmitters

In combination with the SAM Phantom V 4.0, the Mounting Device (POM) enables the rotation of the mounted transmitter in spherical coordinates whereby the rotation points is the ear opening. The devices can be easily, accurately, and repeatably positioned according to the FCC and CENELEC specifications. The device holder can be locked at different phantom locations (left head, right head, flat phantom).

Note: A simulating human hand is not used due to the complex anatomical and geometrical structure of the hand that may produce an infinite number of configurations. To produce the Worst-case condition (the hand absorbs antenna output power), the hand is omitted during the tests.



Figure 3.7 Device Holder

### 3.6 Brain & Muscle Simulating Mixture Characterization

The brain and muscle mixtures consist of a viscous gel using hydrox-ethyl cellulose (HEC) gelling agent and saline solution (see Table 3.1). Preservation with a bactericide is added and visual inspection is made to make sure air bubbles are not trapped during the mixing process. The mixture is calibrated to obtain proper dielectric constant (permittivity) and conductivity of the desired tissue. The mixture characterizations used for the brain and muscle tissue simulating liquids are according to the data by C. Gabriel and G. Hartsgrove.

Ingredients (% by weight)	Frequency (MHz)									
	450		835		915		1 900		2 450	
Tissue Type	Head	Body	Head	Body	Head	Body	Head	Body	Head	Body
Water	38.56	51.16	41.45	52.4	41.05	56.0	54.9	40.4	62.7	73.2
Salt (NaCl)	3.95	1.49	1.45	1.4	1.35	0.76	0.18	0.5	0.5	0.04
Sugar	56.32	46.78	56.0	45.0	56.5	41.76	0.0	58.0	0.0	0.0
HEC	0.98	0.52	1.0	1.0	1.0	1.21	0.0	1.0	0.0	0.0
Bactericide	0.19	0.05	0.1	0.1	0.1	0.27	0.0	0.1	0.0	0.0
Triton X-100	0.0	0.0	0.0	0.0	0.0	0.0	0.0	0.0	36.8	0.0
DGBE	0.0	0.0	0.0	0.0	0.0	0.0	44.92	0.0	0.0	26.7

Salt:	99 % Pure Sodium Chloride	Sugar:	98 % Pure Sucrose
Water:	De-ionized, 16M resistivity	HEC:	Hydroxyethyl Cellulose
DGBE:	99 % Di(ethylene glycol) butyl ether,[2-(2-butoxyethoxy) ethanol]		
Triton X-100(ultra pure):	Polyethylene glycol mono[4-(1,1,3,3-tetramethylbutyl)phenyl] ether		

**Table 3.1 Composition of the Tissue Equivalent Matter**

### 3.7 SAR TEST EQUIPMENT

Manufacturer	Type / Model	S/N	Calib. Date	Calib.Interval	Calib.Due
SPEAG	SAM Phantom	-	N/A	N/A	N/A
Staubli	Robot RX90L	F01/5K09A1/A/01	N/A	N/A	N/A
Staubli	Robot ControllerCS7MB	F99/5A82A1/C/01	N/A	N/A	N/A
HP	Pavilion t000_puffer	KRJ51201TV	N/A	N/A	N/A
SPEAG	Light Alignment Sensor	265	N/A	N/A	N/A
Staubli	Teach Pendant (Joystick)	D221340.01	N/A	N/A	N/A
SPEAG	DAE4	869	Sept. 03, 2008	Annual	Sept. 03, 2009
SPEAG	DAE3	466	July 17, 2008	Annual	July 17, 2009
SPEAG	E-Field Probe ET3DV6	1630	Aug. 25, 2008	Annual	Aug. 25, 2009
SPEAG	E-Field Probe ET3DV6	1609	Mar. 17, 2009	Annual	Mar. 17, 2010
SPEAG	Validation Dipole D450V2	1007	July 15, 2008	Biennial	July 15, 2010
SPEAG	Validation Dipole D835V2	441	May 25, 2009	Annual	May 25, 2010
SPEAG	Validation Dipole D900V2	130	Aug. 25, 2008	Annual	Aug. 25, 2009
SPEAG	Validation Dipole D1800V2	2d007	May 20, 2008	Biennial	May 20, 2010
SPEAG	Validation Dipole D1900V2	5d032	July 22, 2008	Annual	July 22, 2009
SPEAG	Validation Dipole D2450V2	743	Aug. 27, 2008	Biennial	Aug. 27, 2010
Agilent	Power Meter(F) E4419B	MY41291386	Nov. 05, 2008	Annual	Nov. 05, 2009
Agilent	Power Sensor(G) 8481	MY41090870	Nov. 05, 2008	Annual	Nov. 05, 2009
HP	Dielectric Probe Kit 85070C	00721521	N/A	N/A	N/A
HP	Dual Directional Coupler	16072	Nov. 05, 2008	Annual	Nov. 05, 2009
R&S	Base Station CMU200	110740	July 26, 2008	Annual	July 26, 2009
Agilent	Base Station E5515C	GB44400269	Feb. 10, 2009	Annual	Feb. 10, 2010
HP	Signal Generator E4438C	MY42082646	Dec. 24, 2008	Annual	Dec. 24, 2009
HP	Network Analyzer 8753C	3310J01394	Dec. 04, 2008	Annual	Dec. 04, 2009
Tescom	TC-3000/ Bluetooth	3000A490112	Jan. 09, 2009	Annual	Jan. 09, 2010

**NOTE:**

The E-field probe was calibrated by SPEAG, by the waveguide technique procedure. Dipole Validation measurement is performed by HCT Lab. before each test. The brain simulating material is calibrated by HCT using the dielectric probe system and network analyzer to determine the conductivity and permittivity (dielectric constant) of the brain-equivalent material.

## 4. SAR MEASUREMENT PROCEDURE

The evaluation was performed with the following procedure:

1. The SAR value at a fixed location above the ear point was measured and was used as a reference value for assessing the power drop.
2. The SAR distribution at the exposed side of the head was measured at a distance of 3.9 mm from the inner surface of the shell. The area covered the entire dimension of the head and the horizontal grid spacing was 20 mm x 20 mm. Based on this data, the area of the maximum absorption was determined by spline interpolation.
3. Around this point, a volume of 32 mm x 32 mm x 30 mm was assessed by measuring 5 x 5 x 7 points. On this basis of this data set, the spatial peak SAR value was evaluated with the following procedure:
  - a. The data at the surface were extrapolated, since the center of the dipoles is 2.7 mm away from the tip of the probe and the distance between the surface and the lowest measuring point is 1.2 mm. The extrapolation was based on a least square algorithm. A polynomial of the fourth order was calculated through the points in z-axes. This polynomial was then used to evaluate the points between the surface and the probe tip.
  - b. The maximum interpolated value was searched with a straight-forward algorithm. Around this maximum the SAR values averaged over the spatial volumes (1 g or 10 g) were computed using the 3D-Spline interpolation algorithm. The 3D-spline is composed of three one-dimensional splines with the "Not a knot" condition (in x, y, and z directions. The volume was integrated with the trapezoidal algorithm. One thousand points (10 x 10 x 10) were interpolated to calculate the average.
  - c. All neighboring volumes were evaluated until no neighboring volume with a higher average value was found.
4. The SAR value, at the same location as procedure #1, was re-measured. If the value changed by more than 5 %, the evaluation is repeated.

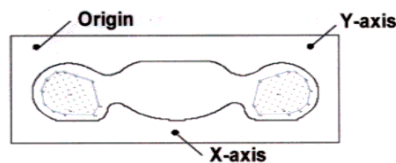

Figure 4.1 SAR Measurement Point in Area Scan

## 5. DESCRIPTION OF TEST POSITION

### 5.1 HEAD POSITION

The device was placed in a normal operating position with the Point A on the device, as illustrated in following drawing, aligned with the location of the RE(ERP) on the phantom. With the ear-piece pressed against the head, the vertical center line of the body of the handset was aligned with an imaginary plane consisting of the RE, LE and M. While maintaining these alignments, the body of the handset was gradually moved towards the cheek until any point on the mouth-piece or keypad contacted the cheek. This is a cheek/touch position. For ear/tilt position, while maintain the device aligned with the BM and FN lines, the device was pivot against ERP back for 15° or until the device antenna touch the phantom. Please refer to IEEE 1528-2003 illustration below.

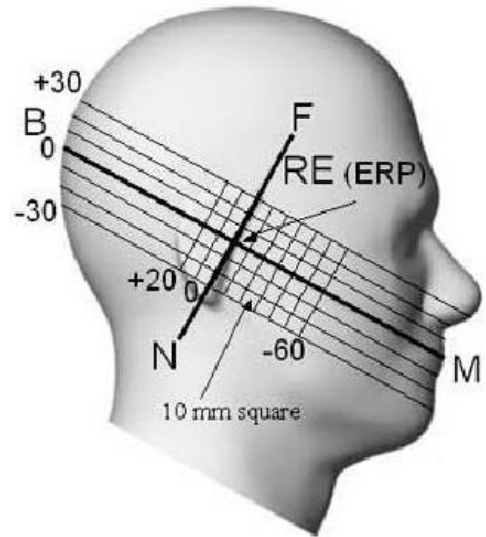

Figure 5.1 Side view of the phantom

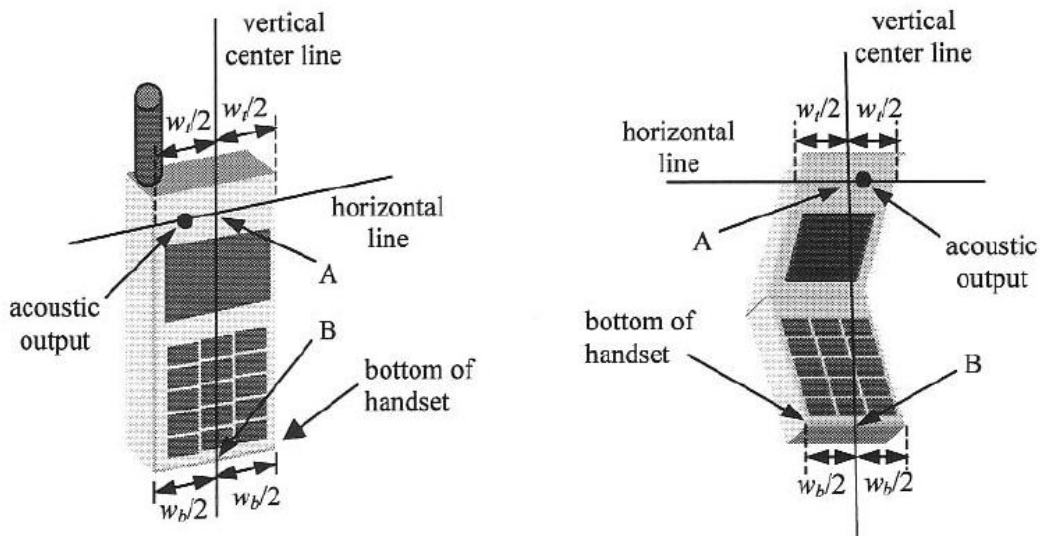

Figure 5.2 Handset vertical and horizontal reference lines

## **5.2 Body Holster/Belt Clip Configurations**

Body-worn operating configurations are tested with the belt-clips and holsters attached to the device and positioned against a flat phantom in a normal use configuration. A device with a headset output is tested with a headset connected to the device. Body dielectric parameters are used.

Accessories for Body-worn operation configurations are divided into two categories: those that do not contain metallic components and those that contain metallic components. When multiple accessories that do not contain metallic components are supplied with the device, the device is tested with only the accessory that dictates the closest spacing to the body. Then multiple accessories that contain metallic components are tested with each accessory. If multiple accessory share an identical metallic component (i.e. the same metallic belt-clip used with different holsters with no other metallic components) only the accessory that dictates the closest spacing to the body is tested.

Body-worn accessories may not always be supplied or available as options for some Devices intended to be authorized for body-worn use. In this case, a test configuration with a separation distance between the back of the device and the flat phantom is used.

Since this EUT does not supply any body worn accessory to the end user a distance of 2.0 cm from the EUT back surface to the liquid interface is configured for the generic test.

"See the Test SET-UP Photo"

Transmitters that are designed to operate in front of a person's face, as in push-to-talk configurations, are tested for SAR compliance with the front of the device positioned to face the flat phantom. For devices that are carried next to the body such as a shoulder, waist or chest-worn transmitters, SAR compliance is tested with the accessory(ies), including headsets and microphones, attached to the device and positioned against a flat phantom in a normal use configuration.

In all cases SAR measurements are performed to investigate the worst-case positioning. Worstcase positioning is then documented and used to perform Body SAR testing.

## 6. MEASUREMENT UNCERTAINTY

Measurement uncertainties in SAR measurements are difficult to quantify due to several variables including biological, physiological, and environmental. However, we estimate the measurement uncertainties in SAR to be less than 15 % - 25 %.

According to ANSI/IEEE C95.3, the overall uncertainties are difficult to assess and will vary with the type of meter and usage situation. However, accuracy's of 1 dB to  $\pm 3$  dB can be expected in practice, with greater uncertainties in near-field situations and at higher frequencies (shorter wavelengths), or areas where large reflecting objects are present. Under optimum measurement conditions, SAR measurement uncertainties of at least  $\pm 2$  dB can be expected.

According to CENELEC, typical worst-case uncertainty of field measurements is 5 dB. For well-defined modulation characteristics the uncertainty can be reduced to  $\pm 3$  dB.

Error Description	Uncertainty value [%]	Probability Distribution	Divisor	ci	ci <sup>2</sup>	Standard Uncertainty [%]	Stand Uncert <sup>2</sup>	(Stand Uncert <sup>2</sup> ) X (ci <sup>2</sup> )	Vi & Veff
<b>1. Measurement System</b>									
Probe Calibration	5.5	Normal	1.00	1	1	5.50	30.25	30.25	$\infty$
Axial Isotropy	4.7	Rectangular	1.73	0.7	0.49	2.71	7.36	3.61	$\infty$
Hemispherical Isotropy	9.6	Rectangular	1.73	0.7	0.49	5.54	30.72	15.05	$\infty$
Linearity	4.7	Rectangular	1.73	1	1	2.71	7.36	7.36	$\infty$
System Detection limits	1.0	Rectangular	1.73	1	1	0.58	0.33	0.33	$\infty$
Boundary effect	1.0	Rectangular	1.73	1	1	0.58	0.33	0.33	$\infty$
Response time	0.8	Rectangular	1.73	1	1	0.46	0.21	0.21	$\infty$
RF Ambient conditions	3.0	Rectangular	1.73	1	1	1.73	3.00	3.00	$\infty$
Readout Electronics	0.3	Normal	1.00	1	1	0.30	0.09	0.09	$\infty$
Integration time	2.6	Rectangular	1.73	1	1	1.50	2.25	2.25	$\infty$
Probe positioner	0.4	Rectangular	1.73	1	1	0.23	0.05	0.05	$\infty$
Probe positioning	2.9	Rectangular	1.73	1	1	1.67	2.80	2.80	$\infty$
Maximum SAR evaluation	1.0	Rectangular	1.73	1	1	0.58	0.33	0.33	$\infty$
<b>Sub Total</b>								<b>65.69</b>	
<b>2. Test Sample Related</b>									
Device Positioning	1.8	Normal	1.00	1	1	1.81	3.28	3.28	9
Device Holder	3.6	Normal	1.00	1	1	3.60	12.96	12.96	$\infty$
Power Drift	5.0	Rectangular	1.73	1	1	2.89	8.33	8.33	$\infty$
<b>Sub Total</b>								<b>24.57</b>	
<b>3. Phantom and Setup</b>									
Phantom Uncertainty	4.0	Rectangular	1.73	1	1	2.31	5.33	5.33	$\infty$
Liquid conductivity (target)	5.0	Rectangular	1.73	0.5	0.25	2.89	8.33	2.08	$\infty$
Liquid conductivity (measurement error)	2.5	Normal	1.00	0.5	0.25	2.50	6.25	1.56	$\infty$
Liquid permittivity (target)	5.0	Rectangular	1.73	0.5	0.25	2.89	8.33	2.08	$\infty$
Liquid permittivity (measurement error)	2.5	Normal	1.00	0.5	0.25	2.50	6.25	1.56	$\infty$
<b>Sub Total</b>								<b>12.63</b>	
<b>Combined standard uncertainty [%]</b>						<b>10.14</b>		<b>102.88</b>	<b>-</b>
<b>Expanded uncertainty [k=2, approximately confidence level 95 %]</b>						<b><math>\pm 20.28</math> %</b>			

**Table 6.1 Breakdown of Errors**

## 7. ANSI/ IEEE C95.1 - 2005 RF EXPOSURE LIMITS

HUMAN EXPOSURE	UNCONTROLLED ENVIRONMENT General Population (W/kg) or (mW/g)	CONTROLLED ENVIRONMENT Occupational (W/kg) or (mW/g)
SPATIAL PEAK SAR * (Brain)	1.60	8.00
SPATIAL AVERAGE SAR ** (Whole Body)	0.08	0.40
SPATIAL PEAK SAR *** (Hands / Feet / Ankle / Wrist)	4.00	20.00

**Table 7.1 Safety Limits for Partial Body Exposure**

**NOTES:**

\* The Spatial Peak value of the SAR averaged over any 1 g of tissue (defined as a tissue volume in the shape of a cube) and over the appropriate averaging time.

\*\* The Spatial Average value of the SAR averaged over the whole-body.

\*\*\* The Spatial Peak value of the SAR averaged over any 10 g of tissue (defined as a tissue volume in the shape of a cube) and over the appropriate averaging time.

**Uncontrolled Environments** are defined as locations where there is the exposure of individuals who have no knowledge or control of their exposure.

**Controlled Environments** are defined as locations where there is exposure that may be incurred by persons who are aware of the potential for exposure, (i.e.as a result of employment or occupation).

## 8. SYSTEM VERIFICATION

### 8.1 Tissue Verification

Freq. [MHz]	Date	Liquid	Liquid Temp.[°C]	Parameters	Target Value	Measured Value	Deviation [%]	Limit [%]
835	Jun.17, 2009	Head	21.2	$\epsilon_r$	41.5	42.6	+ 2.65	± 5
				$\sigma$	0.90	0.866	- 3.78	± 5
835	Jun.17, 2009	Body	21.2	$\epsilon_r$	55.2	54.1	- 1.99	± 5
				$\sigma$	0.97	0.99	+ 2.06	± 5
1 900	Jun.18, 2009	Head	21.3	$\epsilon_r$	40.0	40.2	+ 0.50	± 5
				$\sigma$	1.40	1.46	+ 4.29	± 5
1 900	Jun.18, 2009	Body	21.3	$\epsilon_r$	53.3	51.9	- 2.63	± 5
				$\sigma$	1.52	1.52	0.00	± 5
2 450	Jul.31, 2009	Head	21.3	$\epsilon_r$	39.2	39.7	+ 1.28	± 5
				$\sigma$	1.80	1.84	+ 2.22	± 5
2 450	Jul.31, 2009	Body	21.3	$\epsilon_r$	52.7	51.8	- 1.71	± 5
				$\sigma$	1.95	1.95	0	± 5

### 8.2 System Validation

Prior to assessment, the system is verified to the ± 10 % of the specifications at 835 MHz / 1 900 MHz / 2 450 MHz by using the system validation kit. (Graphic Plots Attached)

\* Input Power: 100 m W

Freq. [MHz]	Date	Liquid	Liquid Temp. [°C]	SAR Average	Target Value (SPEAG) (mW/g)	Measured Value (mW/g)	Deviation [%]	Limit [%]
835	Jun.17, 2009	Head	21.2	1 g	9.56	0.976	+ 2.09	± 10
1 900	Jun.18, 2009	Head	21.3	1 g	37.7	3.86	+ 2.39	± 10
2 450	Jul.31, 2009	Head	21.3	1 g	52.4	5.28	+ 0.76	± 10

## 9. TEST CONFIGURATIONS

### SAR Testing with IEEE 802.11 a/b/g Transmitters

Normal Network operating configurations are not suitable for measuring the SAR of 802.11 a/b/g transmitters. Unpredictable fluctuations in network traffic and antenna diversity conditions can introduce undesirable variations in SAR results. The SAR for these devices should be measured using chipset based test mode software to ensure the results are consistent and reliable.

#### 9.1 General Device Setup

Chipset based test mode software is hardware dependent and generally varies among manufacturers. The device operating parameters established in test mode for SAR measurements must be identical to those programmed in production units, including output power levels, amplifier gain settings and other RF performance tuning parameters. The test frequencies should correspond to actual channel frequencies defined for domestic use. SAR for devices with switched diversity should be measured with only one antenna transmitting at a time during each SAR measurement, according to a fixed modulation and data rate. The same data pattern should be used for all measurements.

#### 9.2 Frequency Channel Configurations

80.11 a/b/g and 4.9 GHz operating modes are tested independently according to the service requirements in each frequency band. 80.211 b/g modes are tested on channels 1, 6 and 11. 802.11a is tested for UNII operations on channels 36 and 48 in the 5.15-5.25 GHz band; channels 52 and 64 in the 5.25-5.35 GHz band; Channels 104, 116, 124 and 136 in the 5.470-5.725 GHz band; and channels 149 and 161 in the 5.8 GHz band. When 5.8 GHz § 15.247 is also available, channels 149, 157 and 165 should be tested instead of the UNII channels. 4.9 GHz is tested on channels 1, 10 and 5 or 6, whichever has the higher output power, for 5 MHz channels; channels 11,15 and 19 for 10 MHz channels; and channels 21 and 25 for 20 MHz channels.

These are referred to as the “default test channels”. 802.11g mode was evaluated only if the output power was 0.25 dB higher than the 802.11b mode.

Mode	GHz	Channel	Turbo Channel	“Default Test Channels”		
				§15.247		UNII
				802.11b	802.11g	
802.11 b/g	2.412	1		√	∇	
	2.437	6	6	√	∇	
	2.462	11		√	∇	
802.11a	5.18	36				√
	5.20	40	42 (5.21 GHz)			*
	5.22	44				*
	5.24	48	50 (5.25 GHz)			√
	5.26	52				√
	5.28	56	58 (5.29 GHz)			*
	5.30	60				*
	5.32	64				√
	5.500	100	Unknown			*
	5.520	104				√
	5.540	108				*
	5.560	112				*
	5.580	116				√
	5.600	120				*
	5.620	124				√
	5.640	128				*
	5.660	132			*	
	5.680	136			√	
	5.700	140			*	
	UNII or §15.247	5.745	149		√	
5.765		153	152 (5.76 GHz)		*	*
5.785		157		√		*
5.805		161	160 (5.80 GHz)		*	√
§15.247		5.825	165		√	

802.11 Test Channels per FCC Requirements

## 10. RF CONDUCTED POWER

Power measurements were performed using a base station simulator under digital average power

### 10.1 Procedures Used to Establish RF Signal for SAR

The handset was placed into a simulated call using a base station simulator in a shielded chamber. Such test signals offer a consistent means for testing SAR and are recommended for evaluation SAR[4] SAR measurements were taken with a fully charged battery. In order to verify that the device was tested and maintained at full power, this was configured with the base station simulator. The SAR measurement Software calculates a reference point at the start and end of the test to check for power drifts. If conducted Power deviations of more than 5 % occurred, the tests were repeated.

Band	Channel	Voice	GPRS Data				EDGE Data			
		GSM (dBm)	GPRS 1 TX Slot (dBm)	GPRS 2 TX Slot (dBm)	GPRS 3 TX Slot (dBm)	GPRS 4 TX Slot (dBm)	EDGE 1 TX Slot (dBm)	EDGE 2 TX Slot (dBm)	EDGE 3 TX Slot (dBm)	EDGE 4 TX Slot (dBm)
GSM 850	128	32.65	32.59	31.07	29.18	28.02	27.22	27.20	27.19	27.14
	190	32.62	32.57	31.04	29.15	28.00	27.19	27.17	27.15	27.11
	251	32.57	32.52	31.00	29.09	27.95	27.14	27.12	27.09	27.07
GSM 1900	512	29.48	29.43	29.42	29.37	29.34	26.05	26.04	26.01	25.99
	661	29.51	29.46	29.44	29.39	29.36	26.08	26.07	26.03	26.01
	810	29.66	29.61	29.59	29.53	29.51	26.22	26.21	26.17	26.15

Table 10.1 GSM Conducted output powers

Band	Channel	HSDPA INACTIVE		HSDPA ACTIVE
		12.2kbps RMC (dBm)	12.2kbps ARM (dBm)	12.2kbps RMC (dBm)
WCDMA 850	4132	22.60	22.62	22.37
	4183	22.58	22.60	22.27
	4233	22.48	22.48	22.04

Table 10.2 WCDMA Conducted output powers

Band	Channel	Mbps			
		1	2	5.5	11
IEEE 802.11b	1	17.88	17.87	18.57	20.88
	6	18.96	19.07	19.28	22.15
	11	17.37	17.58	18.30	20.83

Table 10.2 IEEE 802.11b Conducted output power

Band	Channel	Mbps							
		6	9	12	18	24	36	48	54
IEEE 802.11g	1	18.33	18.15	18.40	18.43	18.86	18.46	18.32	18.50
	6	19.18	19.26	19.47	19.26	19.80	19.65	19.38	19.62
	11	17.82	17.85	18.03	17.98	18.35	18.03	18.17	18.15

Table 10.3 IEEE 802.11g Conducted output power

# 11. SAR Evaluation Considerations for Handsets with Multiple Transmitters and Antennas

## 11.1 SAR Evaluation Considerations

These procedures were followed according to FCC "SAR Evaluation Considerations for Handsets with Multiple Transmitters and Antennas", May 2008. The procedures are applicable to phones with built-in unlicensed transmitters, such as 802.11 a/b/g and Bluetooth devices.

	<b>2.45</b>	<b>5.15 - 5.35</b>	<b>5.47 - 5.85</b>	<b>GHz</b>
<b>P<sub>Ref</sub></b>	<b>12</b>	<b>6</b>	<b>5</b>	<b>mW</b>

Device output power should be rounded to the nearest mW to compare with values specified in this

Table. 10.1 Output Power Thresholds for Unlicensed Transmitters

	Individual Transmitter	Simultaneous Transmission
<b>Licensed Transmitters</b>	<u>Routine evaluation required</u>	<b>SAR not required:</b> <u>Unlicensed only</u>
<b>Unlicensed Transmitters</b>	<p><u>When there is no simultaneous transmission –</u></p> <ul style="list-style-type: none"> <li>output ≤ 60/f: SAR not required</li> <li>output &gt; 60/f: stand-alone SAR required</li> </ul> <p><u>When there is simultaneous transmission – Stand-alone SAR not required when</u></p> <ul style="list-style-type: none"> <li>output ≤ 2·P<sub>Ref</sub> and antenna is ≥ 5.0 cm from other antennas</li> <li>output ≤ P<sub>Ref</sub> and antenna is ≥ 2.5 cm from other antennas</li> <li>output ≤ P<sub>Ref</sub> and antenna is &lt; 2.5 cm from other antennas, each with either output power ≤ P<sub>Ref</sub> or 1-g SAR &lt; 1.2 W/kg</li> </ul> <p><u>Otherwise stand-alone SAR is required</u></p> <p><u>When stand-alone SAR is required</u></p> <ul style="list-style-type: none"> <li>test SAR on highest output channel for each wireless mode and exposure condition</li> <li>if SAR for highest output channel is &gt; 50% of SAR limit, evaluate all channels according to normal procedures</li> </ul>	<ul style="list-style-type: none"> <li>when stand-alone 1-g SAR is not required and antenna is ≥ 5 cm from other antennas</li> </ul> <p><u>Licensed &amp; Unlicensed</u></p> <ul style="list-style-type: none"> <li>when the sum of the 1-g SAR is &lt; 1.6 W/kg for all simultaneous transmitting antennas</li> <li>when SAR to peak location separation ratio of simultaneous transmitting antenna pair is &lt; 0.3</li> </ul> <p><b>SAR required:</b> <u>Licensed &amp; Unlicensed</u></p> <p>antenna pairs with SAR to peak location separation ratio ≥ 0.3; test is only required for the configuration that results in the highest SAR in stand-alone configuration for each wireless mode and exposure condition</p> <p><b>Note: simultaneous transmission exposure conditions for head and body can be different for different style phones; therefore, different test requirements may apply</b></p>
<b>Jaw, Mouth and Nose</b>	<p><u>Flat phantom SAR required</u></p> <ul style="list-style-type: none"> <li>when measurement is required in tight regions of SAM and it is not feasible or the results can be questionable due to probe tilt, calibration, positioning and orientation issues</li> <li>position rectangular and clam-shell phones according to flat phantom procedures and conduct SAR measurements for these specific locations</li> </ul>	When simultaneous transmission SAR testing is required, contact the FCC Laboratory for interim guidance.

Table. 10.2 SAR Evaluation Requirements for Cellphones with Multiple Transmitters

FCC ID: BEJBL40F

BT Max. RF output power: 7.22 dBm (5.27 mW)

Antenna separation distance between Main and BT/ WLAN: 6.0 cm

WLAN Max. RF output power: 802.11b: 22.15 dBm, 802.11g: 19.80 dBm

Because the conducted output power level of the BT transmitter is less than 2·P<sub>ref</sub>, and the BT antenna is more than 5.0 cm from the Main antenna, neither simultaneous SAR nor stand-alone BT SAR are required for the EUT. Based on the output power and antenna separation distance, a stand-alone WLAN SAR test is required. The summation of Main and WLAN is (1.08 + 0.043) = 1.123 < 1.6 mW/g. Therefore a simultaneous SAR evaluation is not required.

## 12. SAR TEST DATA SUMMARY

### 12.1 Measurement Results (GSM850 Head SAR Touch)

Frequency		Modulation	Conducted Power (dBm)		Battery	Phantom Position	Antenna Type	SAR(mW/g)
MHz	Channel		Begin	End				
836.6	190 (Mid)	GSM850	32.62	32.43	Standard	Left Ear	Intenna	0.417
836.6	190 (Mid)	GSM850	32.62	32.48	Standard	Right Ear	Intenna	0.377
<b>ANSI/ IEEE C95.1 2005 – Safety Limit</b>						<b>Head</b>		
<b>Spatial Peak</b>						<b>1.6 W/kg (mW/g)</b>		
<b>Uncontrolled Exposure/ General Population</b>						Averaged over 1 gram		

**NOTES:**

- The test data reported are the worst-case SAR value with the antenna-head position set in a typical configuration. Test procedures used are according to FCC/OET Bulletin 65, Supplement C [July 2001].
- All modes of operation were investigated and the worst-case are reported.
- Measured Depth of Simulating Tissue is 15.0 cm ± 0.2 cm.
- Tissue parameters and temperatures are listed on the SAR plot.
- Battery Type  Standard  Extended  Slim  
Batteries are fully charged for all readings.
- Test Signal Call Mode  Manual Test cord  Base Station Simulator
- Justification for reduced test configurations: per FCC/OET Supplement C (July, 2001), if the SAR measured at the middle channel for each test configuration (Left, right, cheek/touch, tilt/ear, extended and retracted) is at least 3.0 dB lower than the SAR limit, testing at the high and low channels is optional for such test configuration(s).

## 12.2 Measurement Results (GSM850 Head SAR Tilt)

Frequency		Modulation	Conducted Power (dBm)		Battery	Phantom Position	Antenna Type	SAR(mW/g)
MHz	Channel		Begin	End				
836.6	190 (Mid)	GSM850	32.62	32.59	Standard	Left Tilt 15°	Intenna	0.275
836.6	190 (Mid)	GSM850	32.62	32.48	Standard	Right Tilt 15°	Intenna	0.264
<b>ANSI/ IEEE C95.1 2005 – Safety Limit</b>						<b>Head</b>		
<b>Spatial Peak</b>						<b>1.6 W/kg (mW/g)</b>		
<b>Uncontrolled Exposure/ General Population</b>						Averaged over 1 gram		

**NOTES:**

- 1 The test data reported are the worst-case SAR value with the antenna-head position set in a typical configuration. Test procedures used are according to FCC/OET Bulletin 65, Supplement C [July 2001].
- 2 All modes of operation were investigated and the worst-case are reported.
- 3 Measured Depth of Simulating Tissue is 15.0 cm ± 0.2 cm.
- 4 Tissue parameters and temperatures are listed on the SAR plot.
- 5 Battery Type                     Standard                     Extended                     Slim  
Batteries are fully charged for all readings.
- 6 Test Signal Call Mode     Manual Test cord             Base Station Simulator
- 7 Justification for reduced test configurations: per FCC/OET Supplement C (July, 2001), if the SAR measured at the middle channel for each test configuration (Left, right, cheek/touch, tilt/ear, extended and retracted) is at least 3.0 dB lower than the SAR limit, testing at the high and low channels is optional for such test configuration(s).

## 12.3 Measurement Results (GSM1900 Head SAR Touch)

Frequency		Modulation	Conducted Power (dBm)		Battery	Phantom Position	Antenna Type	SAR(mW/g)
MHz	Channel		Begin	End				
1 880.0	661 (Mid)	GSM1900	29.51	29.35	Standard	Left Ear	Intenna	0.191
1 880.0	661 (Mid)	GSM1900	29.51	29.36	Standard	Right Ear	Intenna	0.151
<b>ANSI/ IEEE C95.1 2005 – Safety Limit</b>						<b>Head</b>		
<b>Spatial Peak</b>						<b>1.6 W/kg (mW/g)</b>		
<b>Uncontrolled Exposure/ General Population</b>						<small>Averaged over 1 gram</small>		

**NOTES:**

- 1 The test data reported are the worst-case SAR value with the antenna-head position set in a typical configuration. Test procedures used are according to FCC/OET Bulletin 65, Supplement C [July 2001].
- 2 All modes of operation were investigated and the worst-case are reported.
- 3 Measured Depth of Simulating Tissue is 15.0 cm ± 0.2 cm.
- 4 Tissue parameters and temperatures are listed on the SAR plot.
- 5 Battery Type                     Standard                     Extended                     Slim  
Batteries are fully charged for all readings.
- 6 Test Signal Call Mode     Manual Test cord             Base Station Simulator
- 7 Justification for reduced test configurations: per FCC/OET Supplement C (July, 2001), if the SAR measured at the middle channel for each test configuration (Left, right, cheek/touch, tilt/ear, extended and retracted) is at least 3.0 dB lower than the SAR limit, testing at the high and low channels is optional for such test configuration(s).

## 12.4 Measurement Results (GSM1900 Head SAR Tilt)

Frequency		Modulation	Conducted Power (dBm)		Battery	Phantom Position	Antenna Type	SAR(mW/g)
MHz	Channel		Begin	End				
1 880.0	661 (Mid)	GSM1900	29.51	29.50	Standard	Left Tilt 15°	Intenna	0.104
1 880.0	661 (Mid)	GSM1900	29.51	29.53	Standard	Right Tilt 15°	Intenna	0.100
<b>ANSI/ IEEE C95.1 2005 – Safety Limit</b>						<b>Head</b>		
<b>Spatial Peak</b>						<b>1.6 W/kg (mW/g)</b>		
<b>Uncontrolled Exposure/ General Population</b>						<small>Averaged over 1 gram</small>		

**NOTES:**

- The test data reported are the worst-case SAR value with the antenna-head position set in a typical configuration. Test procedures used are according to FCC/OET Bulletin 65, Supplement C [July 2001].
- All modes of operation were investigated and the worst-case are reported.
- Measured Depth of Simulating Tissue is 15.0 cm ± 0.2 cm.
- Tissue parameters and temperatures are listed on the SAR plot.
- Battery Type                     Standard                     Extended                     Slim  
Batteries are fully charged for all readings.
- Test Signal Call Mode     Manual Test cord             Base Station Simulator
- Justification for reduced test configurations: per FCC/OET Supplement C (July, 2001), if the SAR measured at the middle channel for each test configuration (Left, right, cheek/touch, tilt/ear, extended and retracted) is at least 3.0 dB lower than the SAR limit, testing at the high and low channels is optional for such test configuration(s).

## 12.5 Measurement Results (WCDMA850 Head SAR Touch)

Frequency		Modulation	Conducted Power (dBm)		Battery	Phantom Position	Antenna Type	SAR(mW/g)
MHz	Channel		Begin	End				
836.6	4183 (Mid)	WCDMA850	22.58	22.51	Standard	Left Ear	Intenna	0.378
836.6	4183 (Mid)	WCDMA850	22.58	22.45	Standard	Right Ear	Intenna	0.335
<b>ANSI/ IEEE C95.1 2005 – Safety Limit</b>						<b>Head</b>		
<b>Spatial Peak</b>						<b>1.6 W/kg (mW/g)</b>		
<b>Uncontrolled Exposure/ General Population</b>						Averaged over 1 gram		

**NOTES:**

- The test data reported are the worst-case SAR value with the antenna-head position set in a typical configuration. Test procedures used are according to FCC/OET Bulletin 65, Supplement C [July 2001].
- All modes of operation were investigated and the worst-case are reported.
- Measured Depth of Simulating Tissue is 15.0 cm ± 0.2 cm.
- Tissue parameters and temperatures are listed on the SAR plot.
- Battery Type  Standard  Extended  Slim  
Batteries are fully charged for all readings.
- Test Signal Call Mode  Manual Test cord  Base Station Simulator
- WCDMA Mode was tested under RMC 12.2 kbps and HSDPA Inactive.
- Justification for reduced test configurations: per FCC/OET Supplement C (July, 2001), if the SAR measured at the middle channel for each test configuration (Left, right, cheek/touch, tilt/ear, extended and retracted) is at least 3.0 dB lower than the SAR limit, testing at the high and low channels is optional for such test configuration(s).

## 12.6 Measurement Results (WCDMA850 Head SAR Tilt)

Frequency		Modulation	Conducted Power (dBm)		Battery	Phantom Position	Antenna Type	SAR(mW/g)
MHz	Channel		Begin	End				
836.6	4183 (Mid)	WCDMA850	22.58	22.56	Standard	Left Ear	Intenna	0.273
836.6	4183 (Mid)	WCDMA850	22.58	22.57	Standard	Right Ear	Intenna	0.262
<b>ANSI/ IEEE C95.1 2005 – Safety Limit</b>						<b>Head</b>		
<b>Spatial Peak</b>						<b>1.6 W/kg (mW/g)</b>		
<b>Uncontrolled Exposure/ General Population</b>						Averaged over 1 gram		

**NOTES:**

- 1 The test data reported are the worst-case SAR value with the antenna-head position set in a typical configuration. Test procedures used are according to FCC/OET Bulletin 65, Supplement C [July 2001].
- 2 All modes of operation were investigated and the worst-case are reported.
- 3 Measured Depth of Simulating Tissue is 15.0 cm ± 0.2 cm.
- 4 Tissue parameters and temperatures are listed on the SAR plot.
- 5 Battery Type                     Standard                     Extended                     Slim  
Batteries are fully charged for all readings.
- 6 Test Signal Call Mode     Manual Test cord             Base Station Simulator
- 7 WCDMA Mode was tested under RMC 12.2 kbps and HSDPA Inactive.
- 8 Justification for reduced test configurations: per FCC/OET Supplement C (July, 2001), if the SAR measured at the middle channel for each test configuration (Left, right, cheek/touch, tilt/ear, extended and retracted) is at least 3.0 dB lower than the SAR limit, testing at the high and low channels is optional for such test configuration(s).

## 12.7 Measurement Results (GSM850 Body SAR)

Frequency		Modulation	Conducted Power (dBm)		Configuration	Phantom Position	Antenna Type	SAR(mW/g)
MHz	Channel		Begin	End				
836.6	190 (Mid)	GPRS 1Tx	32.57	32.57	Rear	2.0 cm without Holster	Intenna	0.734
836.6	190 (Mid)	GPRS 2Tx	31.04	31.08	Rear	2.0 cm without Holster	Intenna	1.08
836.6	190 (Mid)	GPRS 3Tx	29.15	29.15	Rear	2.0 cm without Holster	Intenna	1.01
836.6	190 (Mid)	GPRS 4Tx	28.00	27.88	Rear	2.0 cm without Holster	Intenna	1.03
824.2	128 (Low)	GPRS 2Tx	31.07	31.10	Rear	2.0 cm without Holster	Intenna	0.884
848.8	251 (High)	GPRS 2Tx	31.00	31.08	Rear	2.0 cm without Holster	Intenna	1.04
836.6	190 (Mid)	GPRS 2Tx	31.04	30.88	Front	2.0 cm without Holster	Intenna	0.826
836.6	190 (Mid)	GSM850	32.62	32.80	Rear	2.0 cm without Holster	Intenna	0.748
<b>ANSI/ IEEE C95.1 2005 – Safety Limit</b>						<b>Body</b>		
<b>Spatial Peak</b>						<b>1.6 W/kg (mW/g)</b>		
<b>Uncontrolled Exposure/ General Population</b>						<small>Averaged over 1 gram</small>		

**NOTES:**

- 1 The test data reported are the worst-case SAR value with the antenna-head position set in a typical configuration. Test procedures used are according to FCC/OET Bulletin 65, Supplement C [July 2001].
- 2 All modes of operation were investigated and the worst-case are reported.
- 3 Measured Depth of Simulating Tissue is 15.0 cm ± 0.2 cm.
- 4 Tissue parameters and temperatures are listed on the SAR plot.
- 5 Battery Type                     Standard                     Extended                     Slim  
Batteries are fully charged for all readings.
- 6 Test Signal Call Mode         Manual Test cord         Base Station Simulator
- 7 Both side of the phone were tested and the worst-case side is reported.
- 8 HEADSET was connected.
- 9 Test Configuration             With Holster                     Without Holster

## 12.8 Measurement Results (GSM1900 Body SAR)

Frequency		Modulation	Conducted Power (dBm)		Configuration	Phantom Position	Antenna Type	SAR(mW/g)
MHz	Channel		Begin	End				
1 880.0	661 (Mid)	GPRS 1Tx	29.46	29.33	Rear	2.0 cm without Holster	Intenna	0.207
1 880.0	661 (Mid)	GPRS 2Tx	29.44	29.52	Rear	2.0 cm without Holster	Intenna	0.375
1 880.0	661 (Mid)	GPRS 3Tx	29.39	29.47	Rear	2.0 cm without Holster	Intenna	0.559
1 880.0	661 (Mid)	GPRS 4Tx	29.36	29.30	Rear	2.0 cm without Holster	Intenna	0.744
1 880.0	661 (Mid)	GPRS 4Tx	29.36	29.56	Front	2.0 cm without Holster	Intenna	0.642
1 880.0	661 (Mid)	GSM 1900	29.51	29.46	Rear	2.0 cm without Holster	Intenna	0.204
<b>ANSI/ IEEE C95.1 2005 – Safety Limit</b>						<b>Body</b>		
<b>Spatial Peak</b>						<b>1.6 W/kg (mW/g)</b>		
<b>Uncontrolled Exposure/ General Population</b>						<small>Averaged over 1 gram</small>		

**NOTES:**

- The test data reported are the worst-case SAR value with the antenna-head position set in a typical configuration. Test procedures used are according to FCC/OET Bulletin 65, Supplement C [July 2001].
- All modes of operation were investigated and the worst-case are reported.
- Measured Depth of Simulating Tissue is 15.0 cm ± 0.2 cm.
- Tissue parameters and temperatures are listed on the SAR plot.
- Battery Type  Standard  Extended  Slim  
Batteries are fully charged for all readings.
- Test Signal Call Mode  Manual Test cord  Base Station Simulator
- Both side of the phone were tested and the worst-case side is reported.
- HEADSET was connected.
- Test Configuration  With Holster  Without Holster
- Justification for reduced test configurations: per FCC/OET Supplement C (July, 2001), if the SAR measured at the middle channel for each test configuration (Left, right, cheek/touch, tilt/ear, extended and retracted) is at least 3.0 dB lower than the SAR limit, testing at the high and low channels is optional for such test configuration(s).

## 12.9 Measurement Results (WCDMA850 Body SAR)

Frequency		Modulation	Conducted Power (dBm)		Configuration	Phantom Position	Antenna Type	SAR(mW/g)
MHz	Channel		Begin	End				
836.6	4183 (Mid)	WCDMA850	22.59	22.59	Rear	2.0 cm without Holster	Intenna	0.686
836.6	4183 (Mid)	WCDMA850	22.59	22.64	Front	2.0 cm without Holster	Intenna	0.533
<b>ANSI/ IEEE C95.1 2005 – Safety Limit</b>						<b>Body</b>		
<b>Spatial Peak</b>						<b>1.6 W/kg (mW/g)</b>		
<b>Uncontrolled Exposure/ General Population</b>						<small>Averaged over 1 gram</small>		

**NOTES:**

- 1 The test data reported are the worst-case SAR value with the antenna-head position set in a typical configuration. Test procedures used are according to FCC/OET Bulletin 65, Supplement C [July 2001].
- 2 All modes of operation were investigated and the worst-case are reported.
- 3 Measured Depth of Simulating Tissue is 15.0 cm ± 0.2 cm.
- 4 Tissue parameters and temperatures are listed on the SAR plot.
- 5 Battery Type                     Standard                     Extended                     Slim  
Batteries are fully charged for all readings.
- 6 Test Signal Call Mode     Manual Test cord             Base Station Simulator
- 7 Both side of the phone were tested and the worst-case side is reported.
- 8 HEADSET was connected.
- 9 Test Configuration             With Holster                     Without Holster
- 7 WCDMA Mode was tested under RMC 12.2 kbps and HSDPA Inactive.
- 10 Justification for reduced test configurations: per FCC/OET Supplement C (July, 2001), if the SAR measured at the middle channel for each test configuration (Left, right, cheek/touch, tilt/ear, extended and retracted) is at least 3.0 dB lower than the SAR limit, testing at the high and low channels is optional for such test configuration(s).

## 12.10 Measurement Results (802.11b Module Body SAR)

Frequency		Modulation	Conducted Power (dBm)		Configuration	Separation Distance	Data Rate	SAR(mW/g)
MHz	Channel		Begin	End				
2 437	6 (Mid)	802.11b	22.15	22.01	Rear	2.0 cm without Holster	11 Mbps	0.043
2 437	6 (Mid)	802.11b	22.15	22.08	Front	2.0 cm without Holster	11 Mbps	0.017
<b>ANSI/ IEEE C95.1 2005 – Safety Limit</b>						<b>Body</b>		
<b>Spatial Peak</b>						<b>1.6 W/kg (mW/g)</b>		
<b>Uncontrolled Exposure/ General Population</b>						<small>Averaged over 1 gram</small>		

**NOTES:**

- 1 The test data reported are the worst-case SAR value with the antenna-head position set in a typical configuration. Test procedures used are according to FCC/OET Bulletin 65, Supplement C [July 2001].
- 2 All modes of operation were investigated and the worst-case are reported.
- 3 Measured Depth of Simulating Tissue is 15.0 cm ± 0.2 cm.
- 4 Tissue parameters and temperatures are listed on the SAR plot.
- 5 Battery Type                     Standard with Charger     Extended                     Slim  
Batteries are fully charged for all readings.
- 6 Test Signal Call Mode     Manual Test code             Base Station Simulator
- 7 Both side of the phone were tested and the worst-case side is reported.
- 8 Justification for reduced test configurations: per FCC/OET Supplement C (July, 2001), if the SAR measured at the middle channel for each test configuration (Left, right, cheek/touch, tilt/ear, extended and retracted) is at least 3.0 dB lower than the SAR limit, testing at the high and low channels is optional for such test configuration(s).

## **13. CONCLUSION**

---

The SAR measurement indicates that the EUT complies with the RF radiation exposure limits of the ANSI/IEEE C95.1 2005.

These measurements are taken to simulate the RF effects exposure under worst-case conditions. Precise laboratory measures were taken to assure repeatability of the tests.

## 14. REFERENCES

---

- [1] Federal Communications Commission, OET Bulletin 65 (Edition 97-01), Supplement C (Edition 01-01), Evaluating Compliance with FCC Guidelines for Human Exposure to Radio frequency Electromagnetic Fields, July 2001.
- [2] IEEE Standards Coordinating Committee 34 – IEEE Std. 1528-2003, IEEE Recommended Practice for Determining the Peak Spatial-Average Specific Absorption Rate (SAR) in the Human Body from Wireless Communications Devices.
- [3] Federal Communications Commission, ET Docket 93-62, Guidelines for Evaluating the Environmental Effects of Radio frequency Radiation, Aug. 1996.
- [4] ANSI/IEEE C95.1 - 1991, American National Standard safety levels with respect to human exposure to radio frequency electromagnetic fields, 300 kHz to 100 GHz, New York: IEEE, Aug. 1992
- [5] ANSI/IEEE C95.3 - 1991, IEEE Recommended Practice for the Measurement of Potentially Hazardous Electromagnetic Fields - RF and Microwave, New York: IEEE, 1992.
- [6] NCRP, National Council on Radiation Protection and Measurements, Biological Effects and Exposure Criteria for Radio Frequency Electromagnetic Fields, NCRP Report No. 86, 1986. Reprinted Feb. 1995.
- [7] T. Schmid, O. Egger, N. Kuster, Automated E-field scanning system for dosimetric assessments, IEEE Transaction on Microwave Theory and Techniques, vol. 44, Jan. 1996, pp. 105-113.
- [8] K. Pokovic, T. Schmid, N. Kuster, Robust setup for precise calibration of E-field probes in tissue simulating liquids at mobile communications frequencies, ICECOM97, Oct. 1997, pp. 120-124.
- [9] K. Pokovic, T. Schmid, and N. Kuster, E-field Probe with improved isotropy in brain simulating liquids, Proceedings of the ELMAR, Zadar, Croatia, June 23-25, 1996, pp. 172-175.
- [10] Schmid & Partner Engineering AG, Application Note: Data Storage and Evaluation, June 1998, p2.
- [11] V. Hombach, K. Meier, M. Burkhardt, E. Kuhn, N. Kuster, The Dependence of EM Energy Absorption upon Human Head Modeling at 900 MHz, IEEE Transaction on Microwave Theory and Techniques, vol. 44 no. 10, Oct. 1996, pp. 1865-1873.
- [12] N. Kuster and Q. Balzano, Energy absorption mechanism by biological bodies in the near field of dipole antennas above 300 MHz, IEEE Transaction on Vehicular Technology, vol. 41, no. 1, Feb. 1992, pp. 17-23.
- [13] G. Hartsgrove, A. Kraszewski, A. Surowiec, Simulated Biological Materials for Electromagnetic Radiation Absorption Studies, University of Ottawa, Bioelectromagnetics, Canada: 1987, pp. 29-36.
- [14] Q. Balzano, O. Garay, T. Manning Jr., Electromagnetic Energy Exposure of Simulated Users of Portable Cellular Telephones, IEEE Transactions on Vehicular Technology, vol. 44, no.3, Aug. 1995.
- [15] W. Gander, Computer mathematic, Birkhaeuser, Basel, 1992.
- [16] W.H. Press, S.A. Teukolsky, W.T. Vetterling, and B.P. Flannery, Numerical Recipes in C, The Art of Scientific Computing, Second edition, Cambridge University Press, 1992.
- [17] Federal Communications Commission, OET Bulletin 65, Evaluating Compliance with FCC Guidelines for Human Exposure to Radiofrequency Electromagnetic Fields. Supplement C, Dec. 1997.
- [18] N. Kuster, R. Kastle, T. Schmid, Dosimetric evaluation of mobile communications equipment with known precision, IEEE Transaction on Communications, vol. E80-B, no. 5, May 1997, pp. 645-652.
- [19] CENELEC CLC/SC111B, European Prestandard (prENV 50166-2), Human Exposure to Electromagnetic Fields High-frequency: 10 kHz-300 GHz, Jan. 1995.
- [20] Prof. Dr. Niels Kuster, ETH, Eidgenössische Technische Hochschule Zürich, Dosimetric Evaluation of the Cellular Phone.
- [21] SAR Evaluation of Handsets with Multiple Transmitters and Antennas #648474.

## Attachment 1. – SAR Test Plots

Test Laboratory: HCT CO., LTD  
EUT Type: Cellular/PCS WCDMA/GSM/EDGE Phone with WLAN, Bluetooth & FM Transmitter  
GPRS Class 12 and GPRS mode class B(GPRS and GSM, but not simultaneously)  
Liquid Temperature: 21.2 °C  
Ambient Temperature: 21.4 °C  
Test Date: Jun.17, 2009

**DUT: BL40f; Type: Bar; Serial: #1**

Communication System: GSM 850; Frequency: 836.6 MHz; Duty Cycle: 1:8.3  
Medium parameters used (interpolated):  $f = 836.6$  MHz;  $\sigma = 0.867$  mho/m;  $\epsilon_r = 42.6$ ;  $\rho = 1000$  kg/m<sup>3</sup>  
Phantom section: Left Section ; Measurement SW: DASY4, V4.7 Build 80; Postprocessing SW: SEMCAD, V1.8 Build 176

## DASY4 Configuration:

- Probe: ET3DV6 - SN1609; ConvF(6.25, 6.25, 6.25); Calibrated: 2009-03-17
- Sensor-Surface: 4mm (Mechanical Surface Detection)
- Electronics: DAE4 Sn869; Calibrated: 2008-09-03
- Phantom: 835/900 Phantom ; Type: SAM

**Left touch 190/Area Scan (51x101x1):** Measurement grid: dx=15mm, dy=15mm

[Info: Interpolated medium parameters used for SAR evaluation.](#)

Maximum value of SAR (interpolated) = 0.462 mW/g

**Left touch 190/Zoom Scan (5x5x7)/Cube 0:** Measurement grid: dx=8mm, dy=8mm, dz=5mm

Reference Value = 9.66 V/m; Power Drift = -0.186 dB

Peak SAR (extrapolated) = 0.550 W/kg

**SAR(1 g) = 0.417 mW/g; SAR(10 g) = 0.303 mW/g**

[Info: Interpolated medium parameters used for SAR evaluation.](#)

Maximum value of SAR (measured) = 0.435 mW/g

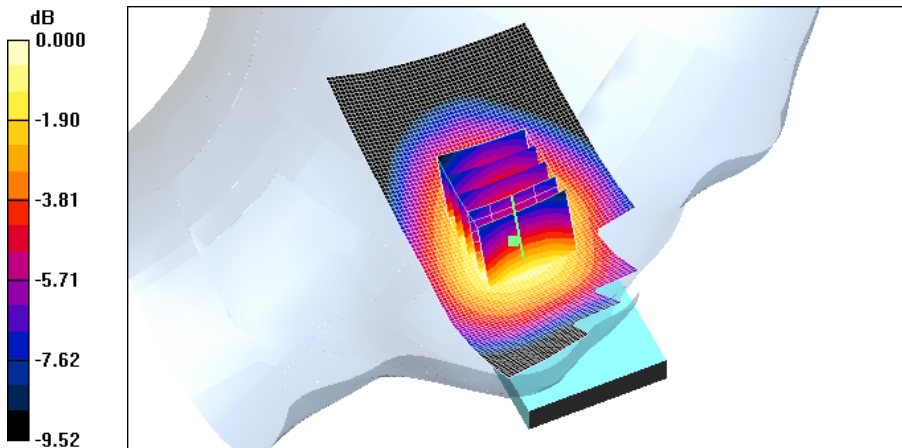

0 dB = 0.435mW/g

Test Laboratory: HCT CO., LTD  
EUT Type: Cellular/PCS WCDMA/GSM/EDGE Phone with WLAN, Bluetooth & FM Transmitter  
GPRS Class 12 and GPRS mode class B(GPRS and GSM, but not simultaneously)  
Liquid Temperature: 21.2 °C  
Ambient Temperature: 21.4 °C  
Test Date: Jun.17, 2009

**DUT: BL40f; Type: Bar; Serial: #1**

Communication System: GSM 850; Frequency: 836.6 MHz; Duty Cycle: 1:8.3  
Medium parameters used (interpolated):  $f = 836.6$  MHz;  $\sigma = 0.867$  mho/m;  $\epsilon_r = 42.6$ ;  $\rho = 1000$  kg/m<sup>3</sup>  
Phantom section: Right Section ; Measurement SW: DASY4, V4.7 Build 80; Postprocessing SW: SEMCAD, V1.8 Build 176

## DASY4 Configuration:

- Probe: ET3DV6 - SN1609; ConvF(6.25, 6.25, 6.25); Calibrated: 2009-03-17
- Sensor-Surface: 4mm (Mechanical Surface Detection)
- Electronics: DAE4 Sn869; Calibrated: 2008-09-03
- Phantom: 835/900 Phantom ; Type: SAM

**Right touch 190/Area Scan (51x101x1):** Measurement grid: dx=15mm, dy=15mm

[Info: Interpolated medium parameters used for SAR evaluation.](#)

Maximum value of SAR (interpolated) = 0.408 mW/g

**Right touch 190/Zoom Scan (5x5x7)/Cube 0:** Measurement grid: dx=8mm, dy=8mm, dz=5mm

Reference Value = 8.18 V/m; Power Drift = -0.138 dB

Peak SAR (extrapolated) = 0.470 W/kg

**SAR(1 g) = 0.377 mW/g; SAR(10 g) = 0.278 mW/g**

[Info: Interpolated medium parameters used for SAR evaluation.](#)

Maximum value of SAR (measured) = 0.405 mW/g

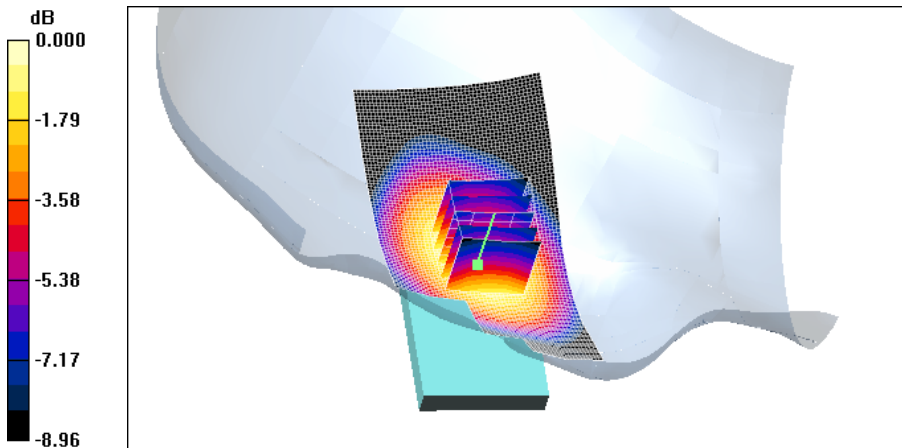

0 dB = 0.405mW/g

Test Laboratory: HCT CO., LTD  
EUT Type: Cellular/PCS WCDMA/GSM/EDGE Phone with WLAN, Bluetooth & FM Transmitter  
GPRS Class 12 and GPRS mode class B(GPRS and GSM, but not simultaneously)  
Liquid Temperature: 21.2 °C  
Ambient Temperature: 21.4 °C  
Test Date: Jun.17, 2009

**DUT: BL40f; Type: Bar; Serial: #1**

Communication System: GSM 850; Frequency: 836.6 MHz; Duty Cycle: 1:8.3  
Medium parameters used (interpolated):  $f = 836.6$  MHz;  $\sigma = 0.867$  mho/m;  $\epsilon_r = 42.6$ ;  $\rho = 1000$  kg/m<sup>3</sup>  
Phantom section: Left Section ; Measurement SW: DASY4, V4.7 Build 80; Postprocessing SW: SEMCAD, V1.8 Build 176

## DASY4 Configuration:

- Probe: ET3DV6 - SN1609; ConvF(6.25, 6.25, 6.25); Calibrated: 2009-03-17
- Sensor-Surface: 4mm (Mechanical Surface Detection)
- Electronics: DAE4 Sn869; Calibrated: 2008-09-03
- Phantom: 835/900 Phantom ; Type: SAM

**Left tilt 190/Area Scan (51x101x1):** Measurement grid: dx=15mm, dy=15mm

[Info: Interpolated medium parameters used for SAR evaluation.](#)

Maximum value of SAR (interpolated) = 0.285 mW/g

**Left tilt 190/Zoom Scan (5x5x7)/Cube 0:** Measurement grid: dx=8mm, dy=8mm, dz=5mm

Reference Value = 14.7 V/m; Power Drift = -0.034 dB

Peak SAR (extrapolated) = 0.344 W/kg

**SAR(1 g) = 0.275 mW/g; SAR(10 g) = 0.203 mW/g**

[Info: Interpolated medium parameters used for SAR evaluation.](#)

Maximum value of SAR (measured) = 0.288 mW/g

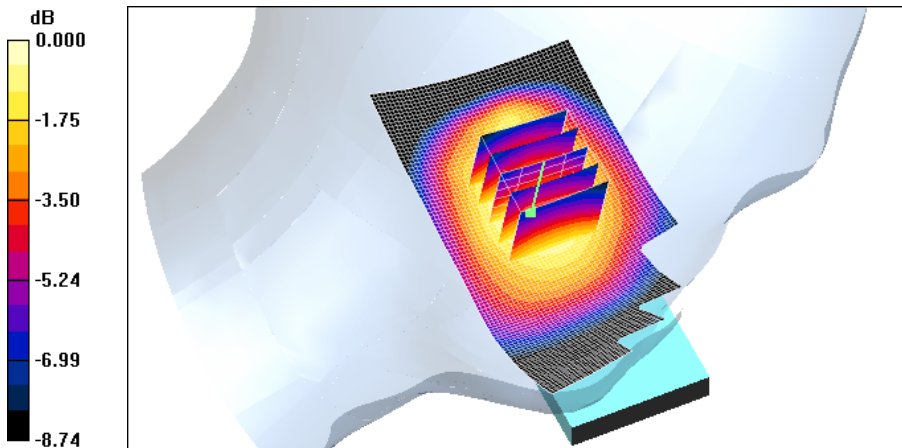

Test Laboratory: HCT CO., LTD  
EUT Type: Cellular/PCS WCDMA/GSM/EDGE Phone with WLAN, Bluetooth & FM Transmitter  
GPRS Class 12 and GPRS mode class B(GPRS and GSM, but not simultaneously)  
Liquid Temperature: 21.2 °C  
Ambient Temperature: 21.4 °C  
Test Date: Jun.17, 2009

**DUT: BL40f; Type: Bar; Serial: #1**

Communication System: GSM 850; Frequency: 836.6 MHz; Duty Cycle: 1:8.3  
Medium parameters used (interpolated):  $f = 836.6$  MHz;  $\sigma = 0.867$  mho/m;  $\epsilon_r = 42.6$ ;  $\rho = 1000$  kg/m<sup>3</sup>  
Phantom section: Right Section ; Measurement SW: DASY4, V4.7 Build 80; Postprocessing SW: SEMCAD, V1.8 Build 176

## DASY4 Configuration:

- Probe: ET3DV6 - SN1609; ConvF(6.25, 6.25, 6.25); Calibrated: 2009-03-17
- Sensor-Surface: 4mm (Mechanical Surface Detection)
- Electronics: DAE4 Sn869; Calibrated: 2008-09-03
- Phantom: 835/900 Phantom ; Type: SAM

**Right tilt 190/Area Scan (51x101x1):** Measurement grid: dx=15mm, dy=15mm

[Info: Interpolated medium parameters used for SAR evaluation.](#)

Maximum value of SAR (interpolated) = 0.280 mW/g

**Right tilt 190/Zoom Scan (5x5x7)/Cube 0:** Measurement grid: dx=8mm, dy=8mm, dz=5mm

Reference Value = 13.0 V/m; Power Drift = -0.015 dB

Peak SAR (extrapolated) = 0.324 W/kg

**SAR(1 g) = 0.264 mW/g; SAR(10 g) = 0.197 mW/g**

[Info: Interpolated medium parameters used for SAR evaluation.](#)

Maximum value of SAR (measured) = 0.279 mW/g

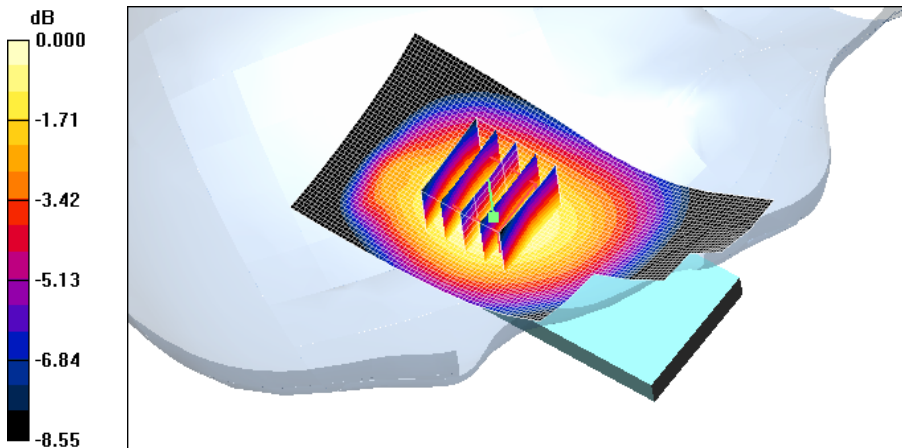

0 dB = 0.279mW/g

Test Laboratory: HCT CO., LTD  
EUT Type: Cellular/PCS WCDMA/GSM/EDGE Phone with WLAN, Bluetooth & FM Transmitter  
GPRS Class 12 and GPRS mode class B(GPRS and GSM, but not simultaneously)  
Liquid Temperature: 21.3 °C  
Ambient Temperature: 21.5 °C  
Test Date: Jun.18, 2009

**DUT: BL40f; Type: Bar; Serial: #1**

Communication System: GSM 1900; Frequency: 1880 MHz; Duty Cycle: 1:8.3  
Medium parameters used:  $f = 1880$  MHz;  $\sigma = 1.45$  mho/m;  $\epsilon_r = 40.4$ ;  $\rho = 1000$  kg/m<sup>3</sup>  
Phantom section: Left Section ; Measurement SW: DASY4, V4.7 Build 80; Postprocessing SW: SEMCAD, V1.8 Build 176

DASY4 Configuration:

- Probe: ET3DV6 - SN1609; ConvF(5.12, 5.12, 5.12); Calibrated: 2009-03-17
- Sensor-Surface: 4mm (Mechanical Surface Detection)
- Electronics: DAE4 Sn869; Calibrated: 2008-09-03
- Phantom: 1800/1900 Phantom; Type: SAM

**Left touch 661/Area Scan (51x101x1):** Measurement grid: dx=15mm, dy=15mm  
Maximum value of SAR (interpolated) = 0.195 mW/g

**Left touch 661/Zoom Scan (5x5x7)/Cube 0:** Measurement grid: dx=8mm, dy=8mm, dz=5mm  
Reference Value = 7.65 V/m; Power Drift = -0.163 dB  
Peak SAR (extrapolated) = 0.302 W/kg  
**SAR(1 g) = 0.191 mW/g; SAR(10 g) = 0.114 mW/g**  
Maximum value of SAR (measured) = 0.216 mW/g

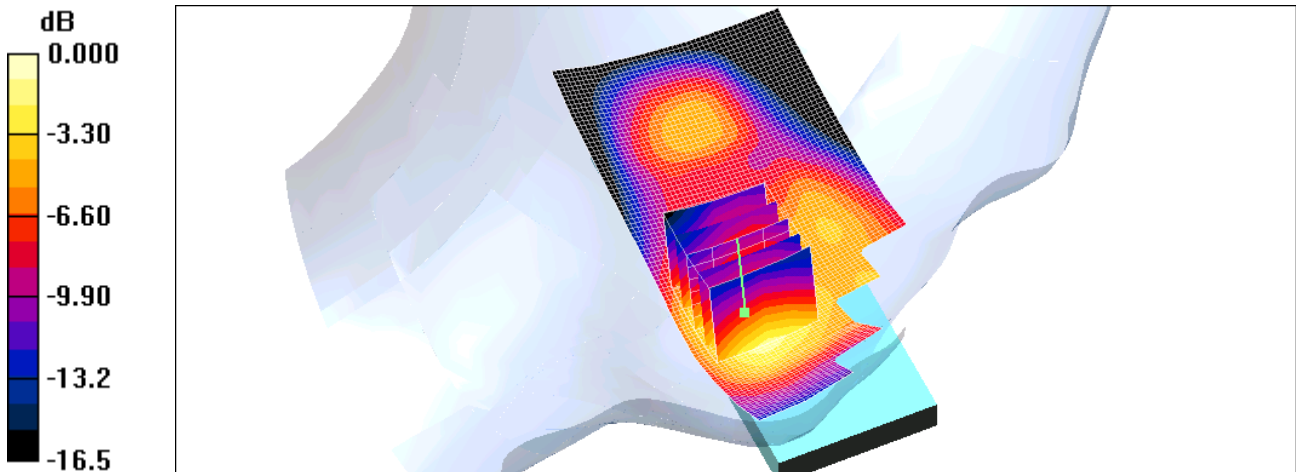

0 dB = 0.216mW/g

Test Laboratory: HCT CO., LTD  
EUT Type: Cellular/PCS WCDMA/GSM/EDGE Phone with WLAN, Bluetooth & FM Transmitter  
GPRS Class 12 and GPRS mode class B(GPRS and GSM, but not simultaneously)  
Liquid Temperature: 21.3 °C  
Ambient Temperature: 21.5 °C  
Test Date: Jun.18, 2009

**DUT: BL40f; Type: Bar; Serial: #1**

Communication System: GSM 1900; Frequency: 1880 MHz; Duty Cycle: 1:8.3  
Medium parameters used:  $f = 1880$  MHz;  $\sigma = 1.45$  mho/m;  $\epsilon_r = 40.4$ ;  $\rho = 1000$  kg/m<sup>3</sup>  
Phantom section: Right Section ; Measurement SW: DASY4, V4.7 Build 80; Postprocessing SW: SEMCAD, V1.8 Build 176

## DASY4 Configuration:

- Probe: ET3DV6 - SN1609; ConvF(5.12, 5.12, 5.12); Calibrated: 2009-03-17
- Sensor-Surface: 4mm (Mechanical Surface Detection)
- Electronics: DAE4 Sn869; Calibrated: 2008-09-03
- Phantom: 1800/1900 Phantom; Type: SAM

**Right touch 661/Area Scan (51x101x1):** Measurement grid: dx=15mm, dy=15mm

Maximum value of SAR (interpolated) = 0.172 mW/g

**Right touch 661/Zoom Scan (5x5x7)/Cube 0:** Measurement grid: dx=8mm, dy=8mm, dz=5mm

Reference Value = 6.93 V/m; Power Drift = -0.146 dB

Peak SAR (extrapolated) = 0.225 W/kg

**SAR(1 g) = 0.151 mW/g; SAR(10 g) = 0.095 mW/g**

Maximum value of SAR (measured) = 0.165 mW/g

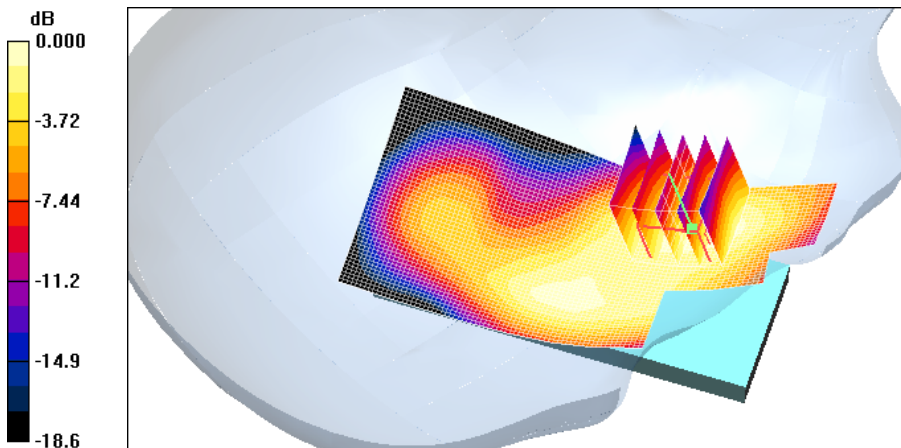

0 dB = 0.165mW/g

Test Laboratory: HCT CO., LTD  
EUT Type: Cellular/PCS WCDMA/GSM/EDGE Phone with WLAN, Bluetooth & FM Transmitter  
GPRS Class 12 and GPRS mode class B(GPRS and GSM, but not simultaneously)  
Liquid Temperature: 21.3 °C  
Ambient Temperature: 21.5 °C  
Test Date: Jun.18, 2009

**DUT: BL40f; Type: Bar; Serial: #1**

Communication System: GSM 1900; Frequency: 1880 MHz; Duty Cycle: 1:8.3  
Medium parameters used:  $f = 1880$  MHz;  $\sigma = 1.45$  mho/m;  $\epsilon_r = 40.4$ ;  $\rho = 1000$  kg/m<sup>3</sup>  
Phantom section: Left Section ; Measurement SW: DASY4, V4.7 Build 80; Postprocessing SW: SEMCAD, V1.8 Build 176

DASY4 Configuration:

- Probe: ET3DV6 - SN1609; ConvF(5.12, 5.12, 5.12); Calibrated: 2009-03-17
- Sensor-Surface: 4mm (Mechanical Surface Detection)
- Electronics: DAE4 Sn869; Calibrated: 2008-09-03
- Phantom: 1800/1900 Phantom; Type: SAM

**Left tilt 661/Area Scan (51x101x1):** Measurement grid: dx=15mm, dy=15mm  
Maximum value of SAR (interpolated) = 0.126 mW/g

**Left tilt 661/Zoom Scan (5x5x7)/Cube 0:** Measurement grid: dx=8mm, dy=8mm, dz=5mm  
Reference Value = 9.54 V/m; Power Drift = -0.008 dB  
Peak SAR (extrapolated) = 0.163 W/kg  
**SAR(1 g) = 0.104 mW/g; SAR(10 g) = 0.057 mW/g**  
Maximum value of SAR (measured) = 0.116 mW/g

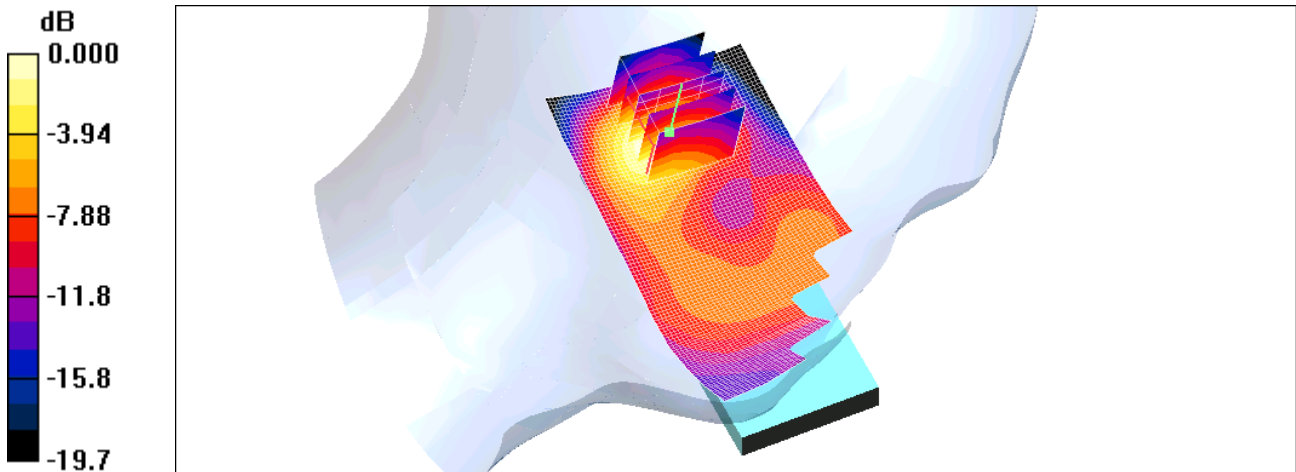

0 dB = 0.116mW/g

Test Laboratory: HCT CO., LTD  
EUT Type: Cellular/PCS WCDMA/GSM/EDGE Phone with WLAN, Bluetooth & FM Transmitter  
GPRS Class 12 and GPRS mode class B(GPRS and GSM, but not simultaneously)  
Liquid Temperature: 21.3 °C  
Ambient Temperature: 21.5 °C  
Test Date: Jun.18, 2009

**DUT: BL40f; Type: Bar; Serial: #1**

Communication System: GSM 1900; Frequency: 1880 MHz; Duty Cycle: 1:8.3  
Medium parameters used:  $f = 1880$  MHz;  $\sigma = 1.45$  mho/m;  $\epsilon_r = 40.4$ ;  $\rho = 1000$  kg/m<sup>3</sup>  
Phantom section: Right Section ; Measurement SW: DASY4, V4.7 Build 80; Postprocessing SW: SEMCAD, V1.8 Build 176

## DASY4 Configuration:

- Probe: ET3DV6 - SN1609; ConvF(5.12, 5.12, 5.12); Calibrated: 2009-03-17
- Sensor-Surface: 4mm (Mechanical Surface Detection)
- Electronics: DAE4 Sn869; Calibrated: 2008-09-03
- Phantom: 1800/1900 Phantom; Type: SAM

**Right tilt 661/Area Scan (51x101x1):** Measurement grid: dx=15mm, dy=15mm

Maximum value of SAR (interpolated) = 0.106 mW/g

**Right tilt 661/Zoom Scan (5x5x7)/Cube 0:** Measurement grid: dx=8mm, dy=8mm, dz=5mm

Reference Value = 8.36 V/m; Power Drift = 0.019 dB

Peak SAR (extrapolated) = 0.162 W/kg

**SAR(1 g) = 0.100 mW/g; SAR(10 g) = 0.057 mW/g**

Maximum value of SAR (measured) = 0.110 mW/g

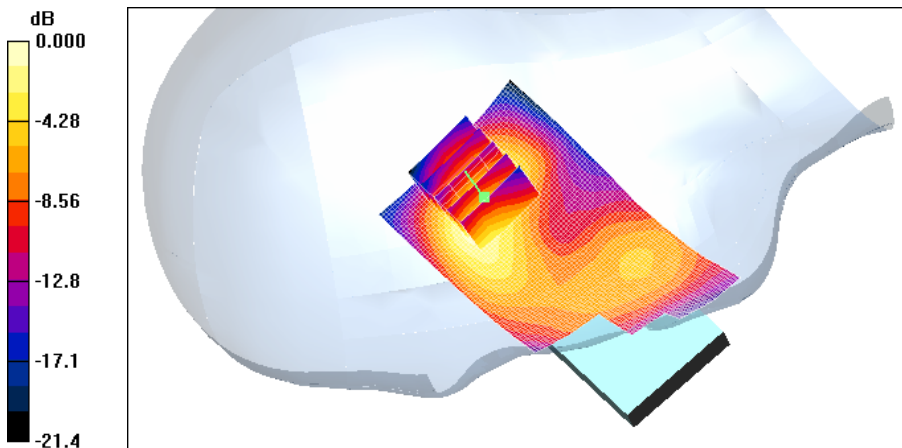

0 dB = 0.110mW/g

Test Laboratory: HCT CO., LTD  
EUT Type: Cellular/PCS WCDMA/GSM/EDGE Phone with WLAN, Bluetooth & FM Transmitter  
GPRS Class 12 and GPRS mode class B(GPRS and GSM, but not simultaneously)  
Liquid Temperature: 21.2 °C  
Ambient Temperature: 21.4 °C  
Test Date: Jun.17, 2009

**DUT: BL40f; Type: Bar; Serial: #1**

Communication System: WCDMA850; Frequency: 836.6 MHz; Duty Cycle: 1:1  
Medium parameters used (interpolated):  $f = 836.6$  MHz;  $\sigma = 0.867$  mho/m;  $\epsilon_r = 42.6$ ;  $\rho = 1000$  kg/m<sup>3</sup>  
Phantom section: Left Section ; Measurement SW: DASY4, V4.7 Build 80; Postprocessing SW: SEMCAD, V1.8 Build 176

## DASY4 Configuration:

- Probe: ET3DV6 - SN1609; ConvF(6.25, 6.25, 6.25); Calibrated: 2009-03-17
- Sensor-Surface: 4mm (Mechanical Surface Detection)
- Electronics: DAE4 Sn869; Calibrated: 2008-09-03
- Phantom: 835/900 Phantom ; Type: SAM

**Left touch 4183/Area Scan (51x101x1):** Measurement grid: dx=15mm, dy=15mm

[Info: Interpolated medium parameters used for SAR evaluation.](#)

Maximum value of SAR (interpolated) = 0.433 mW/g

**Left touch 4183/Zoom Scan (5x5x7)/Cube 0:** Measurement grid: dx=8mm, dy=8mm, dz=5mm

Reference Value = 8.69 V/m; Power Drift = -0.066 dB

Peak SAR (extrapolated) = 0.505 W/kg

**SAR(1 g) = 0.378 mW/g; SAR(10 g) = 0.272 mW/g**

[Info: Interpolated medium parameters used for SAR evaluation.](#)

Maximum value of SAR (measured) = 0.393 mW/g

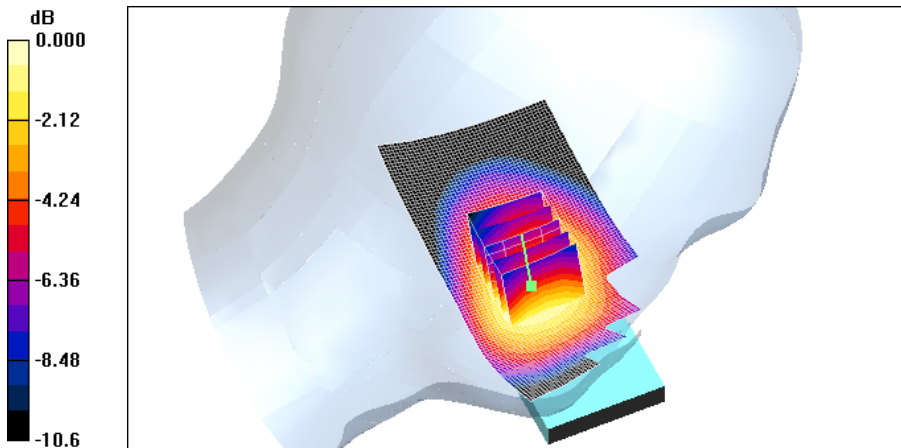

0 dB = 0.393mW/g

Test Laboratory: HCT CO., LTD  
EUT Type: Cellular/PCS WCDMA/GSM/EDGE Phone with WLAN, Bluetooth & FM Transmitter  
GPRS Class 12 and GPRS mode class B(GPRS and GSM, but not simultaneously)  
Liquid Temperature: 21.2 °C  
Ambient Temperature: 21.4 °C  
Test Date: Jun.17, 2009

**DUT: BL40f; Type: Bar; Serial: #1**

Communication System: WCDMA850; Frequency: 836.6 MHz; Duty Cycle: 1:1  
Medium parameters used (interpolated):  $f = 836.6$  MHz;  $\sigma = 0.867$  mho/m;  $\epsilon_r = 42.6$ ;  $\rho = 1000$  kg/m<sup>3</sup>  
Phantom section: Right Section ; Measurement SW: DASY4, V4.7 Build 80; Postprocessing SW: SEMCAD, V1.8 Build 176

## DASY4 Configuration:

- Probe: ET3DV6 - SN1609; ConvF(6.25, 6.25, 6.25); Calibrated: 2009-03-17
- Sensor-Surface: 4mm (Mechanical Surface Detection)
- Electronics: DAE4 Sn869; Calibrated: 2008-09-03
- Phantom: 835/900 Phantom ; Type: SAM

**Right touch 4183/Area Scan (51x101x1):** Measurement grid: dx=15mm, dy=15mm

[Info: Interpolated medium parameters used for SAR evaluation.](#)

Maximum value of SAR (interpolated) = 0.368 mW/g

**Right touch 4183/Zoom Scan (5x5x7)/Cube 0:** Measurement grid: dx=8mm, dy=8mm, dz=5mm

Reference Value = 8.12 V/m; Power Drift = -0.128 dB

Peak SAR (extrapolated) = 0.419 W/kg

**SAR(1 g) = 0.335 mW/g; SAR(10 g) = 0.248 mW/g**

[Info: Interpolated medium parameters used for SAR evaluation.](#)

Maximum value of SAR (measured) = 0.354 mW/g

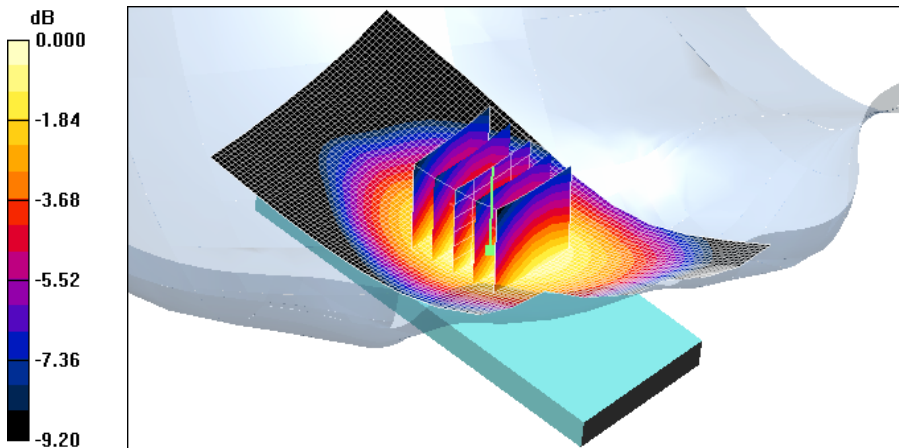

0 dB = 0.354mW/g

Test Laboratory: HCT CO., LTD  
EUT Type: Cellular/PCS WCDMA/GSM/EDGE Phone with WLAN, Bluetooth & FM Transmitter  
GPRS Class 12 and GPRS mode class B(GPRS and GSM, but not simultaneously)  
Liquid Temperature: 21.2 °C  
Ambient Temperature: 21.4 °C  
Test Date: Jun.17, 2009

**DUT: BL40f; Type: Bar; Serial: #1**

Communication System: WCDMA850; Frequency: 836.6 MHz; Duty Cycle: 1:1  
Medium parameters used (interpolated):  $f = 836.6$  MHz;  $\sigma = 0.867$  mho/m;  $\epsilon_r = 42.6$ ;  $\rho = 1000$  kg/m<sup>3</sup>  
Phantom section: Left Section ; Measurement SW: DASY4, V4.7 Build 80; Postprocessing SW: SEMCAD, V1.8 Build 176

## DASY4 Configuration:

- Probe: ET3DV6 - SN1609; ConvF(6.25, 6.25, 6.25); Calibrated: 2009-03-17
- Sensor-Surface: 4mm (Mechanical Surface Detection)
- Electronics: DAE4 Sn869; Calibrated: 2008-09-03
- Phantom: 835/900 Phantom ; Type: SAM

**Left tilt 4183/Area Scan (51x101x1):** Measurement grid: dx=15mm, dy=15mm

[Info: Interpolated medium parameters used for SAR evaluation.](#)

Maximum value of SAR (interpolated) = 0.282 mW/g

**Left tilt 4183/Zoom Scan (5x5x7)/Cube 0:** Measurement grid: dx=8mm, dy=8mm, dz=5mm

Reference Value = 14.7 V/m; Power Drift = -0.025 dB

Peak SAR (extrapolated) = 0.345 W/kg

**SAR(1 g) = 0.273 mW/g; SAR(10 g) = 0.200 mW/g**

[Info: Interpolated medium parameters used for SAR evaluation.](#)

Maximum value of SAR (measured) = 0.288 mW/g

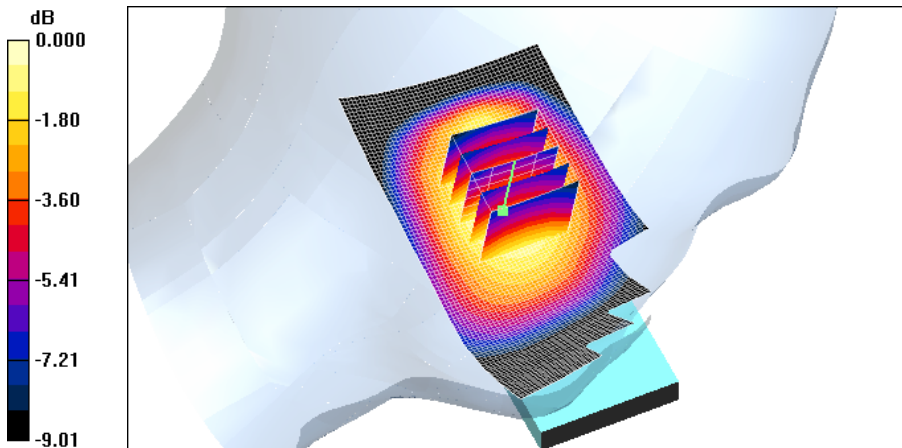

0 dB = 0.288mW/g

Test Laboratory: HCT CO., LTD  
EUT Type: Cellular/PCS WCDMA/GSM/EDGE Phone with WLAN, Bluetooth & FM Transmitter  
GPRS Class 12 and GPRS mode class B(GPRS and GSM, but not simultaneously)  
Liquid Temperature: 21.2 °C  
Ambient Temperature: 21.4 °C  
Test Date: Jun.17, 2009

**DUT: BL40f; Type: Bar; Serial: #1**

Communication System: WCDMA850; Frequency: 836.6 MHz; Duty Cycle: 1:1  
Medium parameters used (interpolated):  $f = 836.6$  MHz;  $\sigma = 0.867$  mho/m;  $\epsilon_r = 42.6$ ;  $\rho = 1000$  kg/m<sup>3</sup>  
Phantom section: Right Section ; Measurement SW: DASY4, V4.7 Build 80; Postprocessing SW: SEMCAD, V1.8 Build 176

## DASY4 Configuration:

- Probe: ET3DV6 - SN1609; ConvF(6.25, 6.25, 6.25); Calibrated: 2009-03-17
- Sensor-Surface: 4mm (Mechanical Surface Detection)
- Electronics: DAE4 Sn869; Calibrated: 2008-09-03
- Phantom: 835/900 Phantom ; Type: SAM

**Right tilt 4183/Area Scan (51x101x1):** Measurement grid: dx=15mm, dy=15mm

[Info: Interpolated medium parameters used for SAR evaluation.](#)

Maximum value of SAR (interpolated) = 0.277 mW/g

**Right tilt 4183/Zoom Scan (5x5x7)/Cube 0:** Measurement grid: dx=8mm, dy=8mm, dz=5mm

Reference Value = 13.3 V/m; Power Drift = -0.007 dB

Peak SAR (extrapolated) = 0.329 W/kg

**SAR(1 g) = 0.262 mW/g; SAR(10 g) = 0.193 mW/g**

[Info: Interpolated medium parameters used for SAR evaluation.](#)

Maximum value of SAR (measured) = 0.275 mW/g

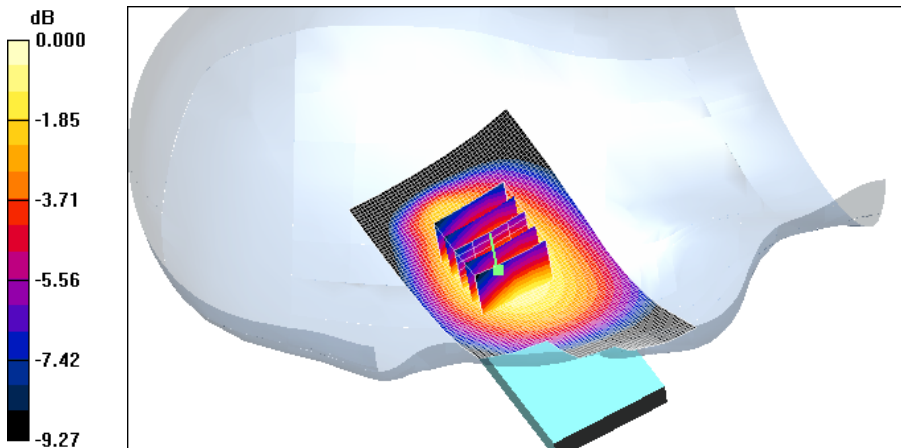

0 dB = 0.275mW/g

Test Laboratory: HCT CO., LTD  
EUT Type: Cellular/PCS WCDMA/GSM/EDGE Phone with WLAN, Bluetooth & FM Transmitter  
GPRS Class 12 and GPRS mode class B(GPRS and GSM, but not simultaneously)  
Liquid Temperature: 21.2 °C  
Ambient Temperature: 21.4 °C  
Test Date: Jun.17, 2009

**DUT: BL40f; Type: Bar; Serial: #1**

Communication System: GSM 850; Frequency: 836.6 MHz; Duty Cycle: 1:8.3  
Medium parameters used (interpolated):  $f = 836.6$  MHz;  $\sigma = 0.992$  mho/m;  $\epsilon_r = 54.1$ ;  $\rho = 1000$  kg/m<sup>3</sup>  
Phantom section: Flat Section ; Measurement SW: DASY4, V4.7 Build 80; Postprocessing SW: SEMCAD, V1.8 Build 176

## DASY4 Configuration:

- Probe: ET3DV6 - SN1609; ConvF(6.08, 6.08, 6.08); Calibrated: 2009-03-17
- Sensor-Surface: 4mm (Mechanical Surface Detection)
- Electronics: DAE4 Sn869; Calibrated: 2008-09-03
- Phantom: 835/900 Phantom ; Type: SAM

**Body 190/Area Scan (51x101x1):** Measurement grid: dx=15mm, dy=15mm

[Info: Interpolated medium parameters used for SAR evaluation.](#)

Maximum value of SAR (interpolated) = 0.781 mW/g

**Body 190/Zoom Scan (5x5x7)/Cube 0:** Measurement grid: dx=8mm, dy=8mm, dz=5mm

Reference Value = 22.6 V/m; Power Drift = -0.002 dB

Peak SAR (extrapolated) = 0.936 W/kg

**SAR(1 g) = 0.734 mW/g; SAR(10 g) = 0.539 mW/g**

[Info: Interpolated medium parameters used for SAR evaluation.](#)

Maximum value of SAR (measured) = 0.771 mW/g

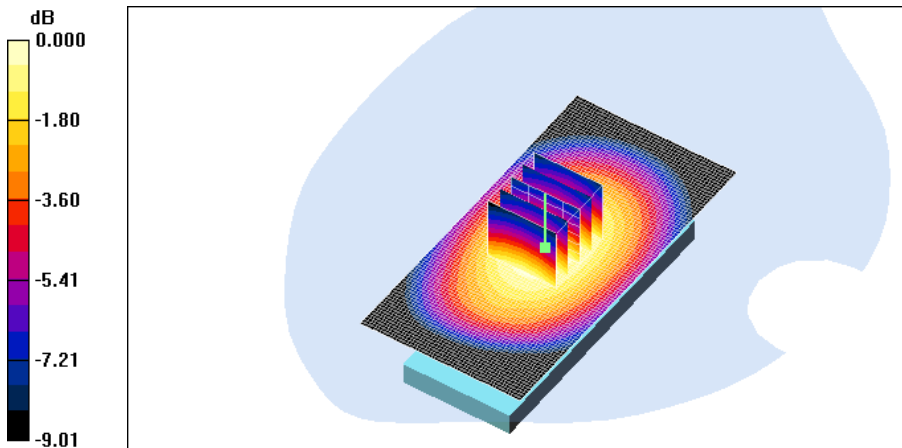

0 dB = 0.771mW/g

Test Laboratory: HCT CO., LTD  
EUT Type: Cellular/PCS WCDMA/GSM/EDGE Phone with WLAN, Bluetooth & FM Transmitter  
GPRS Class 12 and GPRS mode class B(GPRS and GSM, but not simultaneously)  
Liquid Temperature: 21.2 °C  
Ambient Temperature: 21.4 °C  
Test Date: Jun.17, 2009

**DUT: BL40f; Type: Bar; Serial: #1**

Communication System: GSM 850; Frequency: 836.6 MHz; Duty Cycle: 1:4.15  
Medium parameters used (interpolated):  $f = 836.6$  MHz;  $\sigma = 0.992$  mho/m;  $\epsilon_r = 54.1$ ;  $\rho = 1000$  kg/m<sup>3</sup>  
Phantom section: Flat Section ; Measurement SW: DASY4, V4.7 Build 80; Postprocessing SW: SEMCAD, V1.8 Build 176

## DASY4 Configuration:

- Probe: ET3DV6 - SN1609; ConvF(6.08, 6.08, 6.08); Calibrated: 2009-03-17
- Sensor-Surface: 4mm (Mechanical Surface Detection)
- Electronics: DAE4 Sn869; Calibrated: 2008-09-03
- Phantom: 835/900 Phantom ; Type: SAM

**Body 190/Area Scan (51x101x1):** Measurement grid: dx=15mm, dy=15mm

[Info: Interpolated medium parameters used for SAR evaluation.](#)

Maximum value of SAR (interpolated) = 1.14 mW/g

**Body 190/Zoom Scan (5x5x7)/Cube 0:** Measurement grid: dx=8mm, dy=8mm, dz=5mm

Reference Value = 27.4 V/m; Power Drift = 0.035 dB

Peak SAR (extrapolated) = 1.42 W/kg

**SAR(1 g) = 1.08 mW/g; SAR(10 g) = 0.789 mW/g**

[Info: Interpolated medium parameters used for SAR evaluation.](#)

Maximum value of SAR (measured) = 1.15 mW/g

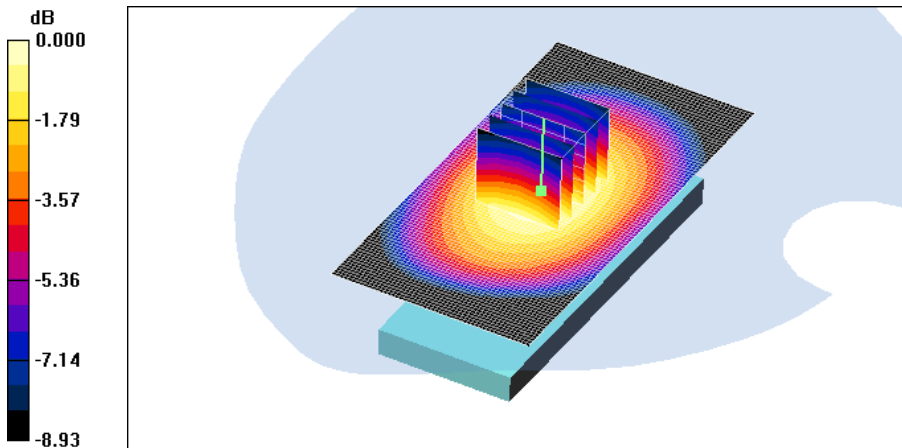

0 dB = 1.15mW/g

Test Laboratory: HCT CO., LTD  
EUT Type: Cellular/PCS WCDMA/GSM/EDGE Phone with WLAN, Bluetooth & FM Transmitter  
GPRS Class 12 and GPRS mode class B(GPRS and GSM, but not simultaneously)  
Liquid Temperature: 21.2 °C  
Ambient Temperature: 21.4 °C  
Test Date: Jun.17, 2009

**DUT: BL40f; Type: Bar; Serial: #1**

Communication System: GSM 850; Frequency: 836.6 MHz; Duty Cycle: 1:2.77  
Medium parameters used (interpolated):  $f = 836.6$  MHz;  $\sigma = 0.992$  mho/m;  $\epsilon_r = 54.1$ ;  $\rho = 1000$  kg/m<sup>3</sup>  
Phantom section: Flat Section ; Measurement SW: DASY4, V4.7 Build 80; Postprocessing SW: SEMCAD, V1.8 Build 176

## DASY4 Configuration:

- Probe: ET3DV6 - SN1609; ConvF(6.08, 6.08, 6.08); Calibrated: 2009-03-17
- Sensor-Surface: 4mm (Mechanical Surface Detection)
- Electronics: DAE4 Sn869; Calibrated: 2008-09-03
- Phantom: 835/900 Phantom ; Type: SAM

**Body 190/Area Scan (51x101x1):** Measurement grid: dx=15mm, dy=15mm

[Info: Interpolated medium parameters used for SAR evaluation.](#)

Maximum value of SAR (interpolated) = 1.06 mW/g

**Body 190/Zoom Scan (5x5x7)/Cube 0:** Measurement grid: dx=8mm, dy=8mm, dz=5mm

Reference Value = 25.3 V/m; Power Drift = 0.003 dB

Peak SAR (extrapolated) = 1.30 W/kg

**SAR(1 g) = 1.01 mW/g; SAR(10 g) = 0.739 mW/g**

[Info: Interpolated medium parameters used for SAR evaluation.](#)

Maximum value of SAR (measured) = 1.06 mW/g

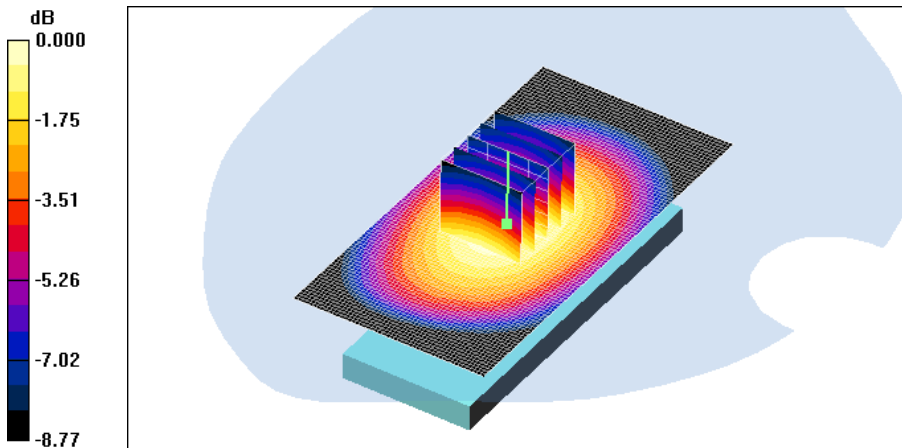

Test Laboratory: HCT CO., LTD  
EUT Type: Cellular/PCS WCDMA/GSM/EDGE Phone with WLAN, Bluetooth & FM Transmitter  
GPRS Class 12 and GPRS mode class B(GPRS and GSM, but not simultaneously)  
Liquid Temperature: 21.2 °C  
Ambient Temperature: 21.4 °C  
Test Date: Jun.17, 2009

**DUT: BL40f; Type: Bar; Serial: #1**

Communication System: GSM 850; Frequency: 836.6 MHz; Duty Cycle: 1:2.075  
Medium parameters used (interpolated):  $f = 836.6$  MHz;  $\sigma = 0.992$  mho/m;  $\epsilon_r = 54.1$ ;  $\rho = 1000$  kg/m<sup>3</sup>  
Phantom section: Flat Section ; Measurement SW: DASY4, V4.7 Build 80; Postprocessing SW: SEMCAD, V1.8 Build 176

## DASY4 Configuration:

- Probe: ET3DV6 - SN1609; ConvF(6.08, 6.08, 6.08); Calibrated: 2009-03-17
- Sensor-Surface: 4mm (Mechanical Surface Detection)
- Electronics: DAE4 Sn869; Calibrated: 2008-09-03
- Phantom: 835/900 Phantom ; Type: SAM

**Body 190/Area Scan (51x101x1):** Measurement grid: dx=15mm, dy=15mm

[Info: Interpolated medium parameters used for SAR evaluation.](#)

Maximum value of SAR (interpolated) = 1.10 mW/g

**Body 190/Zoom Scan (5x5x7)/Cube 0:** Measurement grid: dx=8mm, dy=8mm, dz=5mm

Reference Value = 26.0 V/m; Power Drift = -0.121 dB

Peak SAR (extrapolated) = 1.32 W/kg

**SAR(1 g) = 1.03 mW/g; SAR(10 g) = 0.755 mW/g**

[Info: Interpolated medium parameters used for SAR evaluation.](#)

Maximum value of SAR (measured) = 1.08 mW/g

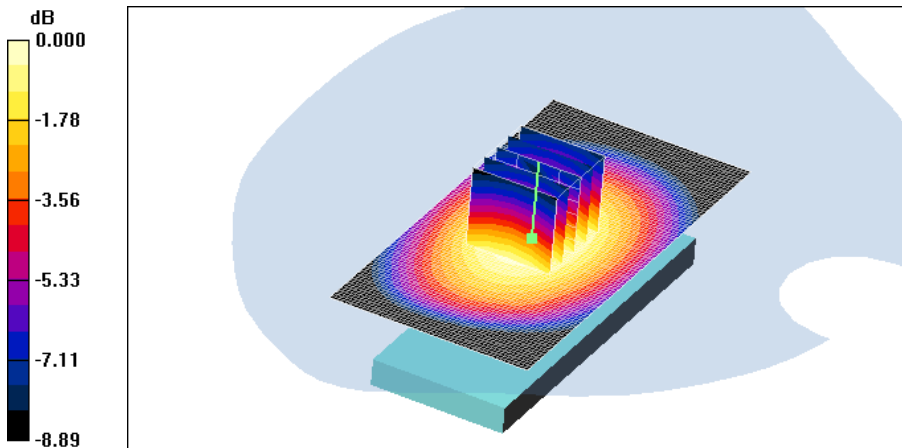

0 dB = 1.08mW/g

Test Laboratory: HCT CO., LTD  
EUT Type: Cellular/PCS WCDMA/GSM/EDGE Phone with WLAN, Bluetooth & FM Transmitter  
GPRS Class 12 and GPRS mode class B(GPRS and GSM, but not simultaneously)  
Liquid Temperature: 21.2 °C  
Ambient Temperature: 21.4 °C  
Test Date: Jun.17, 2009

**DUT: BL40f; Type: Bar; Serial: #1**

Communication System: GSM 850; Frequency: 824.2 MHz; Duty Cycle: 1:4.15  
Medium parameters used:  $f = 825$  MHz;  $\sigma = 0.981$  mho/m;  $\epsilon_r = 54.1$ ;  $\rho = 1000$  kg/m<sup>3</sup>  
Phantom section: Flat Section ; Measurement SW: DASY4, V4.7 Build 80; Postprocessing SW: SEMCAD, V1.8 Build 176

## DASY4 Configuration:

- Probe: ET3DV6 - SN1609; ConvF(6.08, 6.08, 6.08); Calibrated: 2009-03-17
- Sensor-Surface: 4mm (Mechanical Surface Detection)
- Electronics: DAE4 Sn869; Calibrated: 2008-09-03
- Phantom: 835/900 Phantom ; Type: SAM

**Body 128/Area Scan (51x101x1):** Measurement grid: dx=15mm, dy=15mm

Maximum value of SAR (interpolated) = 0.937 mW/g

**Body 128/Zoom Scan (5x5x7)/Cube 0:** Measurement grid: dx=8mm, dy=8mm, dz=5mm

Reference Value = 24.1 V/m; Power Drift = 0.025 dB

Peak SAR (extrapolated) = 1.14 W/kg

**SAR(1 g) = 0.884 mW/g; SAR(10 g) = 0.648 mW/g**

Maximum value of SAR (measured) = 0.932 mW/g

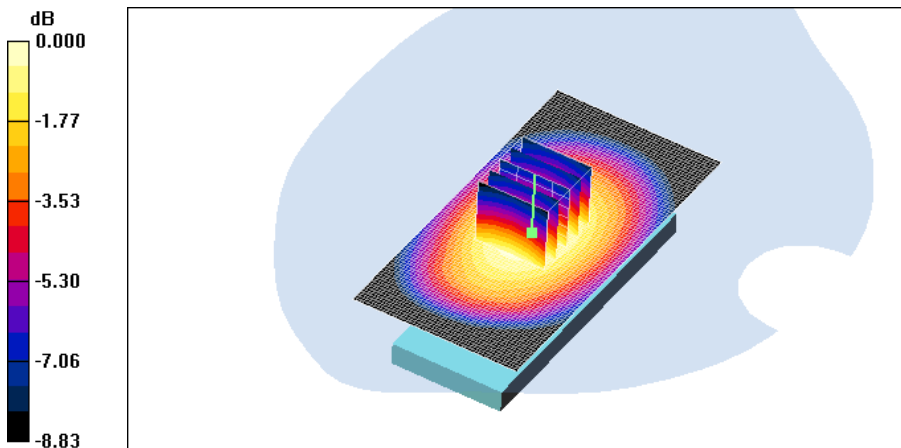

0 dB = 0.932mW/g

Test Laboratory: HCT CO., LTD  
EUT Type: Cellular/PCS WCDMA/GSM/EDGE Phone with WLAN, Bluetooth & FM Transmitter  
GPRS Class 12 and GPRS mode class B(GPRS and GSM, but not simultaneously)  
Liquid Temperature: 21.2 °C  
Ambient Temperature: 21.4 °C  
Test Date: Jun.17, 2009

**DUT: BL40f; Type: Bar; Serial: #1**

Communication System: GSM 850; Frequency: 848.8 MHz; Duty Cycle: 1:4.15  
Medium parameters used (interpolated):  $f = 848.8$  MHz;  $\sigma = 1$  mho/m;  $\epsilon_r = 53.9$ ;  $\rho = 1000$  kg/m<sup>3</sup>  
Phantom section: Flat Section ; Measurement SW: DASY4, V4.7 Build 80; Postprocessing SW: SEMCAD, V1.8 Build 176

## DASY4 Configuration:

- Probe: ET3DV6 - SN1609; ConvF(6.08, 6.08, 6.08); Calibrated: 2009-03-17
- Sensor-Surface: 4mm (Mechanical Surface Detection)
- Electronics: DAE4 Sn869; Calibrated: 2008-09-03
- Phantom: 835/900 Phantom ; Type: SAM

**Body 251/Area Scan (51x101x1):** Measurement grid: dx=15mm, dy=15mm

[Info: Interpolated medium parameters used for SAR evaluation.](#)

Maximum value of SAR (interpolated) = 1.12 mW/g

**Body 251/Zoom Scan (5x5x7)/Cube 0:** Measurement grid: dx=8mm, dy=8mm, dz=5mm

Reference Value = 26.1 V/m; Power Drift = 0.077 dB

Peak SAR (extrapolated) = 1.35 W/kg

**SAR(1 g) = 1.04 mW/g; SAR(10 g) = 0.767 mW/g**

[Info: Interpolated medium parameters used for SAR evaluation.](#)

Maximum value of SAR (measured) = 1.10 mW/g

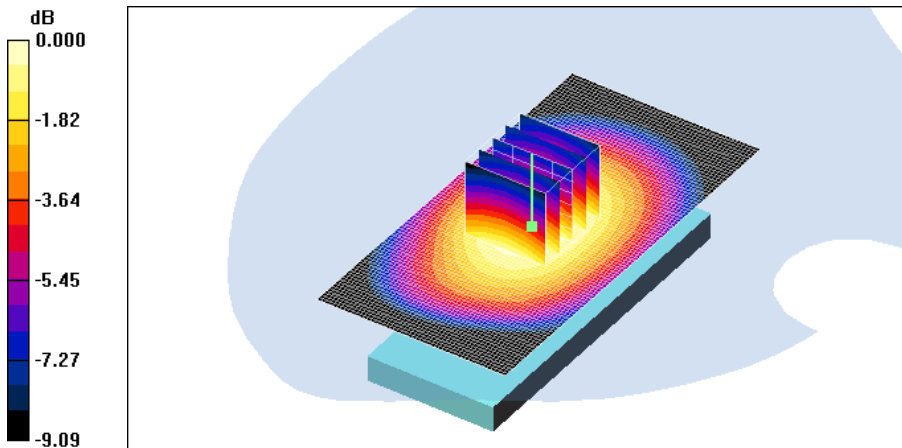

0 dB = 1.10mW/g

Test Laboratory: HCT CO., LTD  
 EUT Type: Cellular/PCS WCDMA/GSM/EDGE Phone with WLAN, Bluetooth & FM Transmitter  
 GPRS Class 12 and GPRS mode class B(GPRS and GSM, but not simultaneously)  
 Liquid Temperature: 21.2 °C  
 Ambient Temperature: 21.4 °C  
 Test Date: Jun.17, 2009

**DUT: BL40f; Type: Bar; Serial: #1**

Communication System: GSM 850; Frequency: 836.6 MHz; Duty Cycle: 1:4.15  
 Medium parameters used (interpolated):  $f = 836.6 \text{ MHz}$ ;  $\sigma = 0.992 \text{ mho/m}$ ;  $\epsilon_r = 54.1$ ;  $\rho = 1000 \text{ kg/m}^3$   
 Phantom section: Flat Section ; Measurement SW: DASY4, V4.7 Build 80; Postprocessing SW: SEMCAD, V1.8 Build 176

DASY4 Configuration:

- Probe: ET3DV6 - SN1609; ConvF(6.08, 6.08, 6.08); Calibrated: 2009-03-17
- Sensor-Surface: 4mm (Mechanical Surface Detection)
- Electronics: DAE4 Sn869; Calibrated: 2008-09-03
- Phantom: 835/900 Phantom ; Type: SAM

**Body 190/Area Scan (51x101x1):** Measurement grid: dx=15mm, dy=15mm

[Info: Interpolated medium parameters used for SAR evaluation.](#)

Maximum value of SAR (interpolated) = 0.879 mW/g

**Body 190/Zoom Scan (5x5x7)/Cube 0:** Measurement grid: dx=8mm, dy=8mm, dz=5mm

Reference Value = 23.5 V/m; Power Drift = -0.156 dB

Peak SAR (extrapolated) = 1.07 W/kg

**SAR(1 g) = 0.826 mW/g; SAR(10 g) = 0.610 mW/g**

[Info: Interpolated medium parameters used for SAR evaluation.](#)

Maximum value of SAR (measured) = 0.872 mW/g

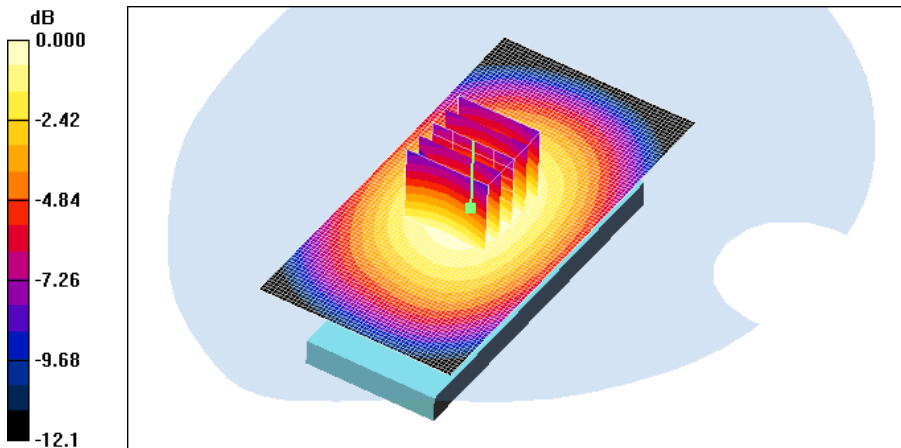

0 dB = 0.872mW/g

Test Laboratory: HCT CO., LTD  
EUT Type: Cellular/PCS WCDMA/GSM/EDGE Phone with WLAN, Bluetooth & FM Transmitter  
GPRS Class 12 and GPRS mode class B(GPRS and GSM, but not simultaneously)  
Liquid Temperature: 21.2 °C  
Ambient Temperature: 21.4 °C  
Test Date: Jun.17, 2009

**DUT: BL40f; Type: Bar; Serial: #1**

Communication System: GSM 850; Frequency: 836.6 MHz; Duty Cycle: 1:8.3  
Medium parameters used (interpolated):  $f = 836.6$  MHz;  $\sigma = 0.992$  mho/m;  $\epsilon_r = 54.1$ ;  $\rho = 1000$  kg/m<sup>3</sup>  
Phantom section: Flat Section ; Measurement SW: DASY4, V4.7 Build 80; Postprocessing SW: SEMCAD, V1.8 Build 176

## DASY4 Configuration:

- Probe: ET3DV6 - SN1609; ConvF(6.08, 6.08, 6.08); Calibrated: 2009-03-17
- Sensor-Surface: 4mm (Mechanical Surface Detection)
- Electronics: DAE4 Sn869; Calibrated: 2008-09-03
- Phantom: 835/900 Phantom ; Type: SAM

**Body 190/Area Scan (51x101x1):** Measurement grid: dx=15mm, dy=15mm

[Info: Interpolated medium parameters used for SAR evaluation.](#)

Maximum value of SAR (interpolated) = 0.799 mW/g

**Body 190/Zoom Scan (5x5x7)/Cube 0:** Measurement grid: dx=8mm, dy=8mm, dz=5mm

Reference Value = 20.6 V/m; Power Drift = 0.178 dB

Peak SAR (extrapolated) = 0.969 W/kg

**SAR(1 g) = 0.748 mW/g; SAR(10 g) = 0.549 mW/g**

[Info: Interpolated medium parameters used for SAR evaluation.](#)

Maximum value of SAR (measured) = 0.786 mW/g

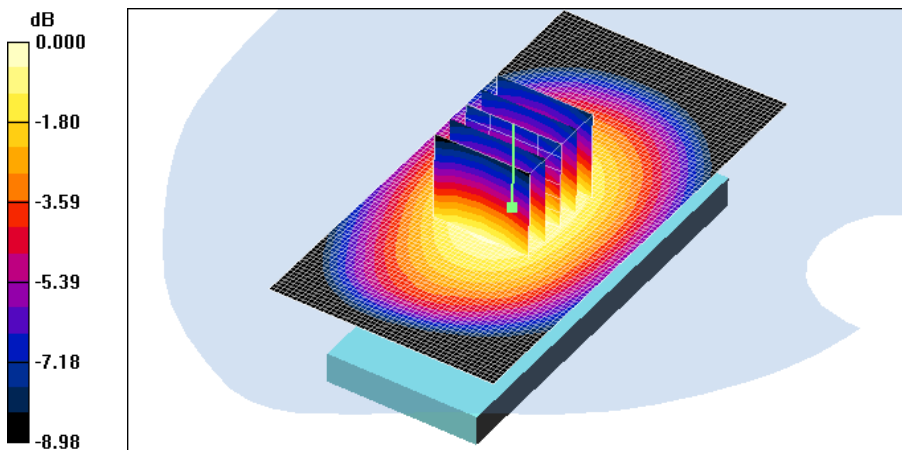

0 dB = 0.786mW/g

Test Laboratory: HCT CO., LTD  
EUT Type: Cellular/PCS WCDMA/GSM/EDGE Phone with WLAN, Bluetooth & FM Transmitter  
GPRS Class 12 and GPRS mode class B(GPRS and GSM, but not simultaneously)  
Liquid Temperature: 21.3 °C  
Ambient Temperature: 21.5 °C  
Test Date: Jun.18, 2009

**DUT: BL40f; Type: Bar; Serial: #1**

Communication System: GSM 1900; Frequency: 1880 MHz; Duty Cycle: 1:8.3  
Medium parameters used:  $f = 1880 \text{ MHz}$ ;  $\sigma = 1.5 \text{ mho/m}$ ;  $\epsilon_r = 52.1$ ;  $\rho = 1000 \text{ kg/m}^3$   
Phantom section: Flat Section ; Measurement SW: DASY4, V4.7 Build 80; Postprocessing SW: SEMCAD, V1.8 Build 176

## DASY4 Configuration:

- Probe: ET3DV6 - SN1609; ConvF(4.61, 4.61, 4.61); Calibrated: 2009-03-17
- Sensor-Surface: 4mm (Mechanical Surface Detection)
- Electronics: DAE4 Sn869; Calibrated: 2008-09-03
- Phantom: 1800/1900 Phantom; Type: SAM

**Body 661/Area Scan (51x101x1):** Measurement grid: dx=15mm, dy=15mm

Maximum value of SAR (interpolated) = 0.220 mW/g

**Body 661/Zoom Scan (5x5x7)/Cube 0:** Measurement grid: dx=8mm, dy=8mm, dz=5mm

Reference Value = 2.76 V/m; Power Drift = -0.133 dB

Peak SAR (extrapolated) = 0.277 W/kg

**SAR(1 g) = 0.207 mW/g; SAR(10 g) = 0.128 mW/g**

Maximum value of SAR (measured) = 0.227 mW/g

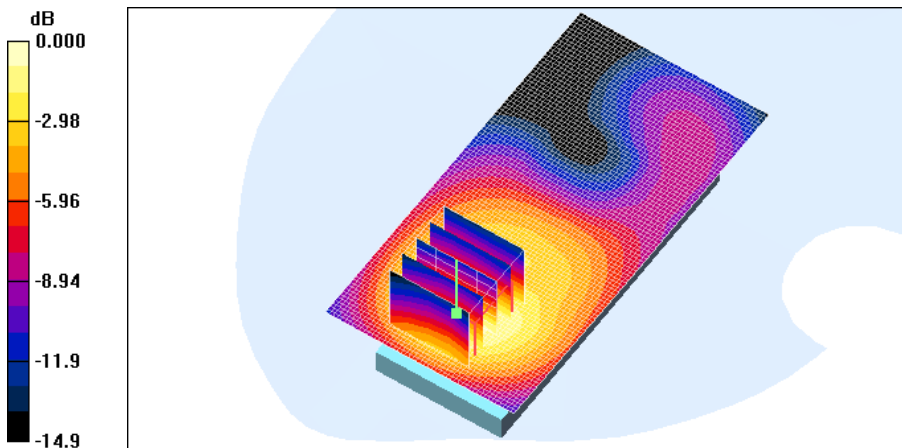

0 dB = 0.227mW/g

Test Laboratory: HCT CO., LTD  
EUT Type: Cellular/PCS WCDMA/GSM/EDGE Phone with WLAN, Bluetooth & FM Transmitter  
GPRS Class 12 and GPRS mode class B(GPRS and GSM, but not simultaneously)  
Liquid Temperature: 21.3 °C  
Ambient Temperature: 21.5 °C  
Test Date: Jun.18, 2009

**DUT: BL40f; Type: Bar; Serial: #1**

Communication System: GSM 1900; Frequency: 1880 MHz; Duty Cycle: 1:4.15  
Medium parameters used:  $f = 1880$  MHz;  $\sigma = 1.5$  mho/m;  $\epsilon_r = 52.1$ ;  $\rho = 1000$  kg/m<sup>3</sup>  
Phantom section: Flat Section ; Measurement SW: DASY4, V4.7 Build 80; Postprocessing SW: SEMCAD, V1.8 Build 176

## DASY4 Configuration:

- Probe: ET3DV6 - SN1609; ConvF(4.61, 4.61, 4.61); Calibrated: 2009-03-17
- Sensor-Surface: 4mm (Mechanical Surface Detection)
- Electronics: DAE4 Sn869; Calibrated: 2008-09-03
- Phantom: 1800/1900 Phantom; Type: SAM

**Body 661/Area Scan (51x101x1):** Measurement grid: dx=15mm, dy=15mm

Maximum value of SAR (interpolated) = 0.402 mW/g

**Body 661/Zoom Scan (5x5x7)/Cube 0:** Measurement grid: dx=8mm, dy=8mm, dz=5mm

Reference Value = 3.64 V/m; Power Drift = -0.081 dB

Peak SAR (extrapolated) = 0.540 W/kg

**SAR(1 g) = 0.375 mW/g; SAR(10 g) = 0.225 mW/g**

Maximum value of SAR (measured) = 0.410 mW/g

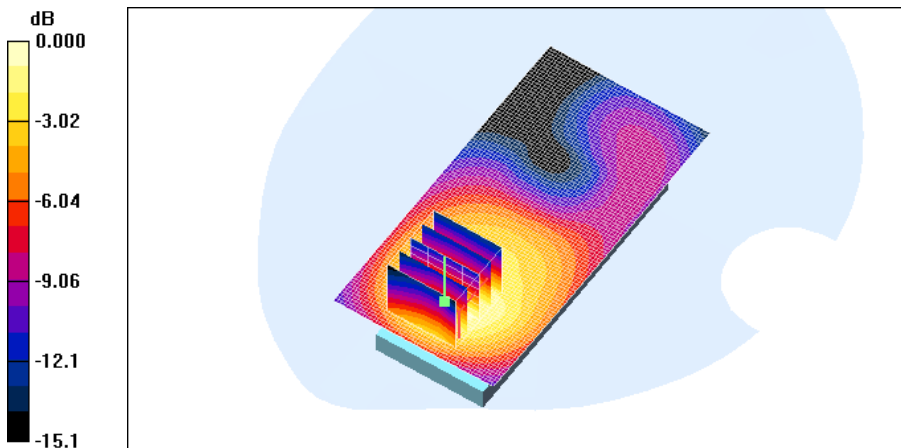

0 dB = 0.410mW/g

Test Laboratory: HCT CO., LTD  
EUT Type: Cellular/PCS WCDMA/GSM/EDGE Phone with WLAN, Bluetooth & FM Transmitter  
GPRS Class 12 and GPRS mode class B(GPRS and GSM, but not simultaneously)  
Liquid Temperature: 21.3 °C  
Ambient Temperature: 21.5 °C  
Test Date: Jun.18, 2009

**DUT: BL40f; Type: Bar; Serial: #1**

Communication System: GSM 1900; Frequency: 1880 MHz; Duty Cycle: 1:2.77  
Medium parameters used:  $f = 1880$  MHz;  $\sigma = 1.5$  mho/m;  $\epsilon_r = 52.1$ ;  $\rho = 1000$  kg/m<sup>3</sup>  
Phantom section: Flat Section ; Measurement SW: DASY4, V4.7 Build 80; Postprocessing SW: SEMCAD, V1.8 Build 176

## DASY4 Configuration:

- Probe: ET3DV6 - SN1609; ConvF(4.61, 4.61, 4.61); Calibrated: 2009-03-17
- Sensor-Surface: 4mm (Mechanical Surface Detection)
- Electronics: DAE4 Sn869; Calibrated: 2008-09-03
- Phantom: 1800/1900 Phantom; Type: SAM

**Body 661/Area Scan (51x101x1):** Measurement grid: dx=15mm, dy=15mm

Maximum value of SAR (interpolated) = 0.594 mW/g

**Body 661/Zoom Scan (5x5x7)/Cube 0:** Measurement grid: dx=8mm, dy=8mm, dz=5mm

Reference Value = 4.42 V/m; Power Drift = 0.082 dB

Peak SAR (extrapolated) = 0.761 W/kg

**SAR(1 g) = 0.559 mW/g; SAR(10 g) = 0.345 mW/g**

Maximum value of SAR (measured) = 0.612 mW/g

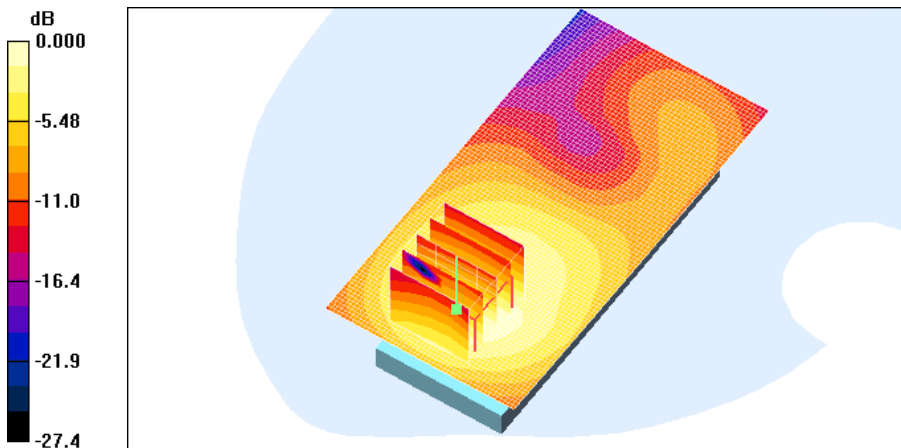

0 dB = 0.612mW/g

Test Laboratory: HCT CO., LTD  
EUT Type: Cellular/PCS WCDMA/GSM/EDGE Phone with WLAN, Bluetooth & FM Transmitter  
GPRS Class 12 and GPRS mode class B(GPRS and GSM, but not simultaneously)  
Liquid Temperature: 21.3 °C  
Ambient Temperature: 21.5 °C  
Test Date: Jun.18, 2009

**DUT: BL40f; Type: Bar; Serial: #1**

Communication System: GSM 1900; Frequency: 1880 MHz; Duty Cycle: 1:2.075  
Medium parameters used:  $f = 1880$  MHz;  $\sigma = 1.5$  mho/m;  $\epsilon_r = 52.1$ ;  $\rho = 1000$  kg/m<sup>3</sup>  
Phantom section: Flat Section ; Measurement SW: DASY4, V4.7 Build 80; Postprocessing SW: SEMCAD, V1.8 Build 176

## DASY4 Configuration:

- Probe: ET3DV6 - SN1609; ConvF(4.61, 4.61, 4.61); Calibrated: 2009-03-17
- Sensor-Surface: 4mm (Mechanical Surface Detection)
- Electronics: DAE4 Sn869; Calibrated: 2008-09-03
- Phantom: 1800/1900 Phantom; Type: SAM

**Body 661/Area Scan (51x101x1):** Measurement grid: dx=15mm, dy=15mm

Maximum value of SAR (interpolated) = 0.794 mW/g

**Body 661/Zoom Scan (5x5x7)/Cube 0:** Measurement grid: dx=8mm, dy=8mm, dz=5mm

Reference Value = 5.09 V/m; Power Drift = -0.063 dB

Peak SAR (extrapolated) = 1.29 W/kg

**SAR(1 g) = 0.744 mW/g; SAR(10 g) = 0.458 mW/g**

Maximum value of SAR (measured) = 0.801 mW/g

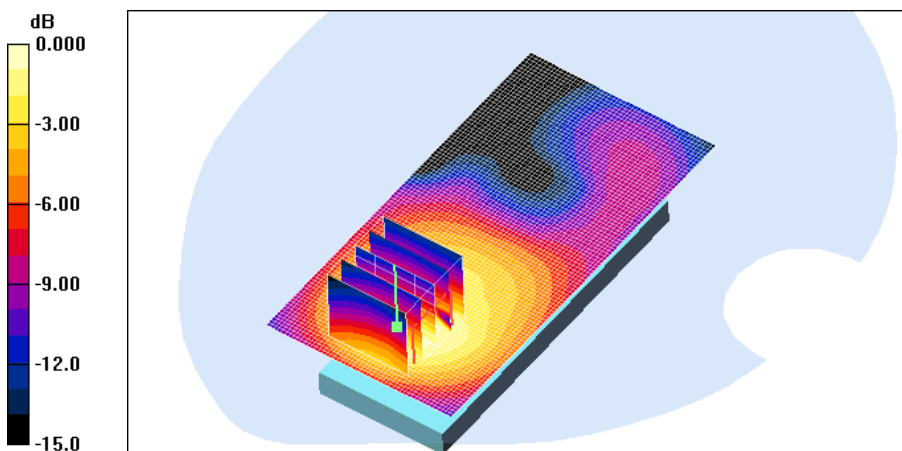

0 dB = 0.801mW/g

Test Laboratory: HCT CO., LTD  
EUT Type: Cellular/PCS WCDMA/GSM/EDGE Phone with WLAN, Bluetooth & FM Transmitter  
GPRS Class 12 and GPRS mode class B(GPRS and GSM, but not simultaneously)  
Liquid Temperature: 21.3 °C  
Ambient Temperature: 21.5 °C  
Test Date: Jun.18, 2009

**DUT: BL40f; Type: Bar; Serial: #1**

Communication System: GSM 1900; Frequency: 1880 MHz; Duty Cycle: 1:2.075  
Medium parameters used:  $f = 1880 \text{ MHz}$ ;  $\sigma = 1.5 \text{ mho/m}$ ;  $\epsilon_r = 52.1$ ;  $\rho = 1000 \text{ kg/m}^3$   
Phantom section: Flat Section ; Measurement SW: DASY4, V4.7 Build 80; Postprocessing SW: SEMCAD, V1.8 Build 176

## DASY4 Configuration:

- Probe: ET3DV6 - SN1609; ConvF(4.61, 4.61, 4.61); Calibrated: 2009-03-17
- Sensor-Surface: 4mm (Mechanical Surface Detection)
- Electronics: DAE4 Sn869; Calibrated: 2008-09-03
- Phantom: 1800/1900 Phantom; Type: SAM

**Body 661/Area Scan (51x101x1):** Measurement grid: dx=15mm, dy=15mm

Maximum value of SAR (interpolated) = 0.736 mW/g

**Body 661/Zoom Scan (5x5x7)/Cube 0:** Measurement grid: dx=8mm, dy=8mm, dz=5mm

Reference Value = 12.1 V/m; Power Drift = -0.199 dB

Peak SAR (extrapolated) = 0.903 W/kg

**SAR(1 g) = 0.642 mW/g; SAR(10 g) = 0.410 mW/g**

Maximum value of SAR (measured) = 0.702 mW/g

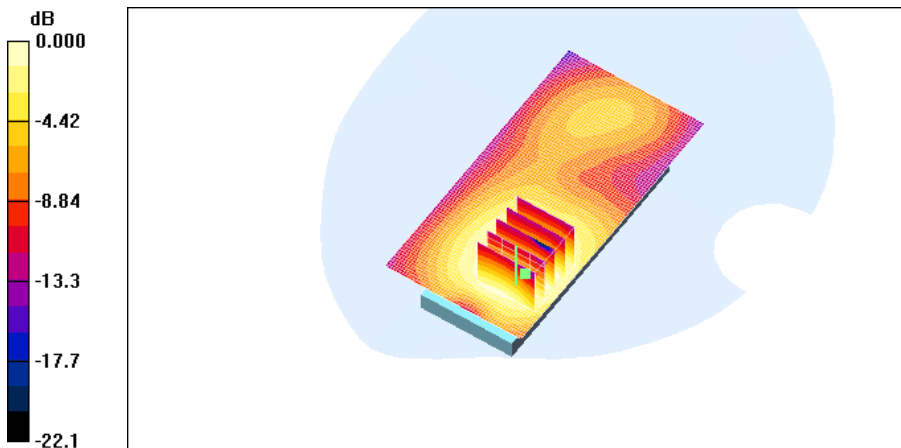

0 dB = 0.702mW/g

Test Laboratory: HCT CO., LTD  
EUT Type: Cellular/PCS WCDMA/GSM/EDGE Phone with WLAN, Bluetooth & FM Transmitter  
GPRS Class 12 and GPRS mode class B(GPRS and GSM, but not simultaneously)  
Liquid Temperature: 21.3 °C  
Ambient Temperature: 21.5 °C  
Test Date: Jun.18, 2009

**DUT: BL40f; Type: Bar; Serial: #1**

Communication System: GSM 1900; Frequency: 1880 MHz; Duty Cycle: 1:8.3  
Medium parameters used:  $f = 1880$  MHz;  $\sigma = 1.5$  mho/m;  $\epsilon_r = 52.1$ ;  $\rho = 1000$  kg/m<sup>3</sup>  
Phantom section: Flat Section ; Measurement SW: DASY4, V4.7 Build 80; Postprocessing SW: SEMCAD, V1.8 Build 176

## DASY4 Configuration:

- Probe: ET3DV6 - SN1609; ConvF(4.61, 4.61, 4.61); Calibrated: 2009-03-17
- Sensor-Surface: 4mm (Mechanical Surface Detection)
- Electronics: DAE4 Sn869; Calibrated: 2008-09-03
- Phantom: 1800/1900 Phantom; Type: SAM

**Body 661/Area Scan (51x101x1):** Measurement grid: dx=15mm, dy=15mm

Maximum value of SAR (interpolated) = 0.221 mW/g

**Body 661/Zoom Scan (5x5x7)/Cube 0:** Measurement grid: dx=8mm, dy=8mm, dz=5mm

Reference Value = 2.75 V/m; Power Drift = -0.046 dB

Peak SAR (extrapolated) = 0.272 W/kg

**SAR(1 g) = 0.204 mW/g; SAR(10 g) = 0.127 mW/g**

Maximum value of SAR (measured) = 0.224 mW/g

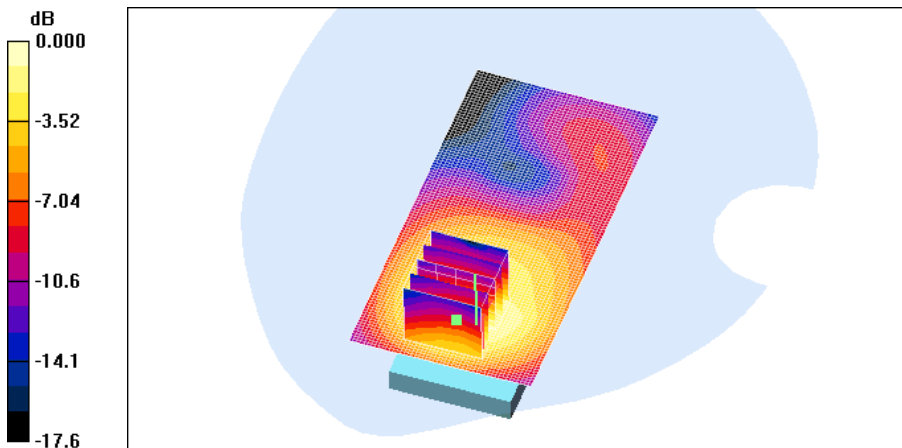

0 dB = 0.224mW/g

Test Laboratory: HCT CO., LTD  
EUT Type: Cellular/PCS WCDMA/GSM/EDGE Phone with WLAN, Bluetooth & FM Transmitter  
GPRS Class 12 and GPRS mode class B(GPRS and GSM, but not simultaneously)  
Liquid Temperature: 21.2 °C  
Ambient Temperature: 21.4 °C  
Test Date: Jun.17, 2009

**DUT: BL40f; Type: Bar; Serial: #1**

Communication System: WCDMA850; Frequency: 836.6 MHz; Duty Cycle: 1:1  
Medium parameters used (interpolated):  $f = 836.6$  MHz;  $\sigma = 0.992$  mho/m;  $\epsilon_r = 54.1$ ;  $\rho = 1000$  kg/m<sup>3</sup>  
Phantom section: Flat Section ; Measurement SW: DASY4, V4.7 Build 80; Postprocessing SW: SEMCAD, V1.8 Build 176

## DASY4 Configuration:

- Probe: ET3DV6 - SN1609; ConvF(6.08, 6.08, 6.08); Calibrated: 2009-03-17
- Sensor-Surface: 4mm (Mechanical Surface Detection)
- Electronics: DAE4 Sn869; Calibrated: 2008-09-03
- Phantom: 835/900 Phantom ; Type: SAM

**Body 4183/Area Scan (51x101x1):** Measurement grid: dx=15mm, dy=15mm

[Info: Interpolated medium parameters used for SAR evaluation.](#)

Maximum value of SAR (interpolated) = 0.731 mW/g

**Body 4183/Zoom Scan (5x5x7)/Cube 0:** Measurement grid: dx=8mm, dy=8mm, dz=5mm

Reference Value = 20.6 V/m; Power Drift = 0.007 dB

Peak SAR (extrapolated) = 0.883 W/kg

**SAR(1 g) = 0.686 mW/g; SAR(10 g) = 0.504 mW/g**

[Info: Interpolated medium parameters used for SAR evaluation.](#)

Maximum value of SAR (measured) = 0.724 mW/g

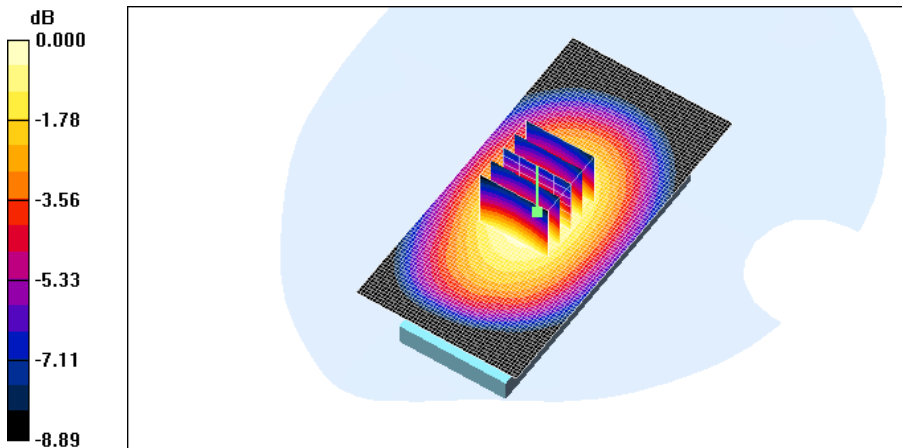

Test Laboratory: HCT CO., LTD  
EUT Type: Cellular/PCS WCDMA/GSM/EDGE Phone with WLAN, Bluetooth & FM Transmitter  
GPRS Class 12 and GPRS mode class B(GPRS and GSM, but not simultaneously)  
Liquid Temperature: 21.2 °C  
Ambient Temperature: 21.4 °C  
Test Date: Jun.17, 2009

**DUT: BL40f; Type: Bar; Serial: #1**

Communication System: WCDMA850; Frequency: 836.6 MHz; Duty Cycle: 1:1  
Medium parameters used (interpolated):  $f = 836.6$  MHz;  $\sigma = 0.992$  mho/m;  $\epsilon_r = 54.1$ ;  $\rho = 1000$  kg/m<sup>3</sup>  
Phantom section: Flat Section ; Measurement SW: DASY4, V4.7 Build 80; Postprocessing SW: SEMCAD, V1.8 Build 176

## DASY4 Configuration:

- Probe: ET3DV6 - SN1609; ConvF(6.08, 6.08, 6.08); Calibrated: 2009-03-17
- Sensor-Surface: 4mm (Mechanical Surface Detection)
- Electronics: DAE4 Sn869; Calibrated: 2008-09-03
- Phantom: 835/900 Phantom ; Type: SAM

**Body 4183/Area Scan (51x101x1):** Measurement grid: dx=15mm, dy=15mm

[Info: Interpolated medium parameters used for SAR evaluation.](#)

Maximum value of SAR (interpolated) = 0.565 mW/g

**Body 4183/Zoom Scan (5x5x7)/Cube 0:** Measurement grid: dx=8mm, dy=8mm, dz=5mm

Reference Value = 17.9 V/m; Power Drift = 0.061 dB

Peak SAR (extrapolated) = 0.677 W/kg

**SAR(1 g) = 0.533 mW/g; SAR(10 g) = 0.394 mW/g**

[Info: Interpolated medium parameters used for SAR evaluation.](#)

Maximum value of SAR (measured) = 0.562 mW/g

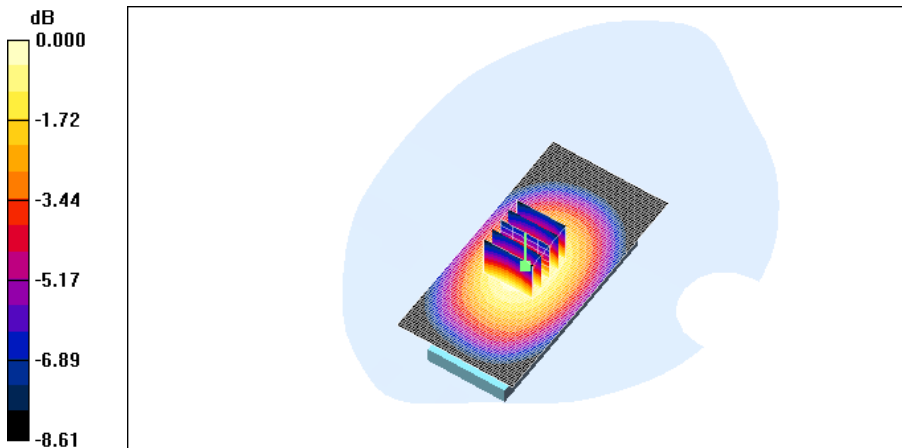

0 dB = 0.562mW/g

Test Laboratory: HCT CO., LTD  
EUT Type: Cellular/PCS WCDMA/GSM/EDGE Phone with WLAN, Bluetooth & FM Transmitter  
GPRS Class 12 and GPRS mode class B(GPRS and GSM, but not simultaneously)  
Liquid Temperature: 21.3 °C  
Ambient Temperature: 21.5 °C  
Test Date: Jul.31, 2009

**DUT: BL40f; Type: Bar; Serial: #1**

Communication System: 2450MHz FCC; Frequency: 2437 MHz;Duty Cycle: 1:1  
Medium parameters used (interpolated):  $f = 2437$  MHz;  $\sigma = 1.93$  mho/m;  $\epsilon_r = 51.8$ ;  $\rho = 1000$  kg/m<sup>3</sup>  
Phantom section: Flat Section ; Measurement SW: DASY4, V4.7 Build 71; Postprocessing SW: SEMCAD, V1.8 Build 176

## DASY4 Configuration:

- Probe: ET3DV6 - SN1609; ConvF(4, 4, 4); Calibrated: 2009-03-17
- Sensor-Surface: 4mm (Mechanical Surface Detection)
- Electronics: DAE4 Sn869; Calibrated: 2008-09-03
- Phantom: SAM 1800/1900 MHz; Type: SAM

**802.11b WiFi 6/Area Scan (61x101x1):** Measurement grid: dx=15mm, dy=15mm

[Info: Interpolated medium parameters used for SAR evaluation.](#)

Maximum value of SAR (interpolated) = 0.045 mW/g

**802.11b WiFi 6/Zoom Scan (5x5x7)/Cube 0:** Measurement grid: dx=8mm, dy=8mm, dz=5mm

Reference Value = 3.46 V/m; Power Drift = -0.183 dB

Peak SAR (extrapolated) = 0.090 W/kg

**SAR(1 g) = 0.043 mW/g; SAR(10 g) = 0.023 mW/g**

[Info: Interpolated medium parameters used for SAR evaluation.](#)

Maximum value of SAR (measured) = 0.045 mW/g

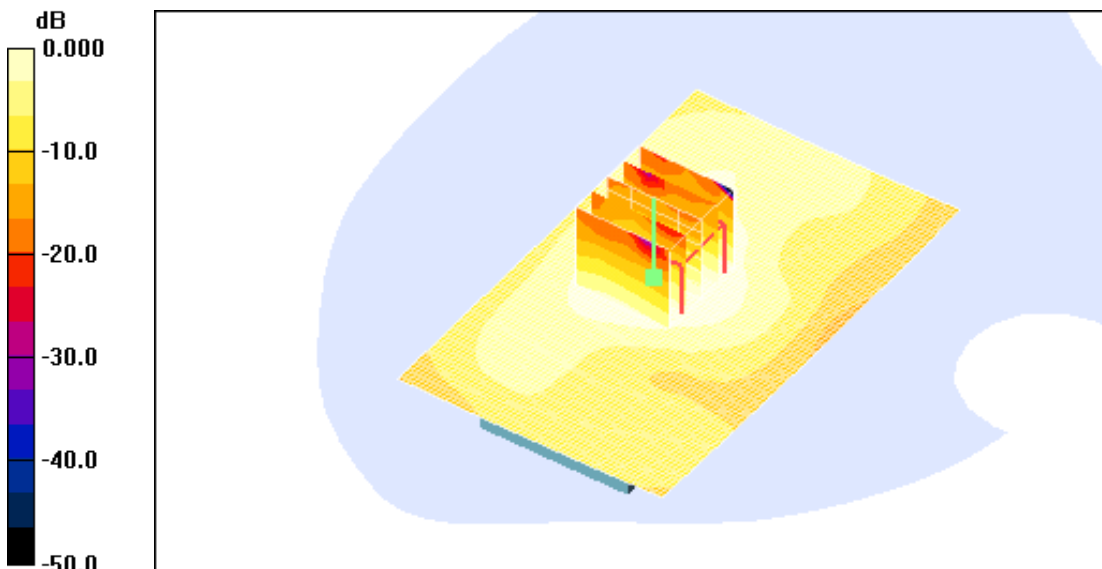

0 dB = 0.045mW/g

Test Laboratory: HCT CO., LTD  
EUT Type: Cellular/PCS WCDMA/GSM/EDGE Phone with WLAN, Bluetooth & FM Transmitter  
GPRS Class 12 and GPRS mode class B(GPRS and GSM, but not simultaneously)  
Liquid Temperature: 21.3 °C  
Ambient Temperature: 21.5 °C  
Test Date: Jul.31, 2009

**DUT: BL40f; Type: Bar; Serial: #1**

Communication System: 2450MHz FCC; Frequency: 2437 MHz;Duty Cycle: 1:1  
Medium parameters used (interpolated):  $f = 2437$  MHz;  $\sigma = 1.93$  mho/m;  $\epsilon_r = 51.8$ ;  $\rho = 1000$  kg/m<sup>3</sup>  
Phantom section: Flat Section ; Measurement SW: DASY4, V4.7 Build 71; Postprocessing SW: SEMCAD, V1.8  
Build 176

DASY4 Configuration:

- Probe: ET3DV6 - SN1609; ConvF(4, 4, 4); Calibrated: 2009-03-17
- Sensor-Surface: 4mm (Mechanical Surface Detection)
- Electronics: DAE4 Sn869; Calibrated: 2008-09-03
- Phantom: SAM 1800/1900 MHz; Type: SAM

**802.11b WiFi 6/Area Scan (61x101x1):** Measurement grid: dx=15mm, dy=15mm

[Info: Interpolated medium parameters used for SAR evaluation.](#)

Maximum value of SAR (interpolated) = 0.018 mW/g

**802.11b WiFi 6/Zoom Scan (5x5x7)/Cube 0:** Measurement grid: dx=8mm, dy=8mm, dz=5mm

Reference Value = 2.23 V/m; Power Drift = -0.076 dB

Peak SAR (extrapolated) = 0.034 W/kg

**SAR(1 g) = 0.017 mW/g; SAR(10 g) = 0.00912 mW/g**

[Info: Interpolated medium parameters used for SAR evaluation.](#)

Maximum value of SAR (measured) = 0.018 mW/g

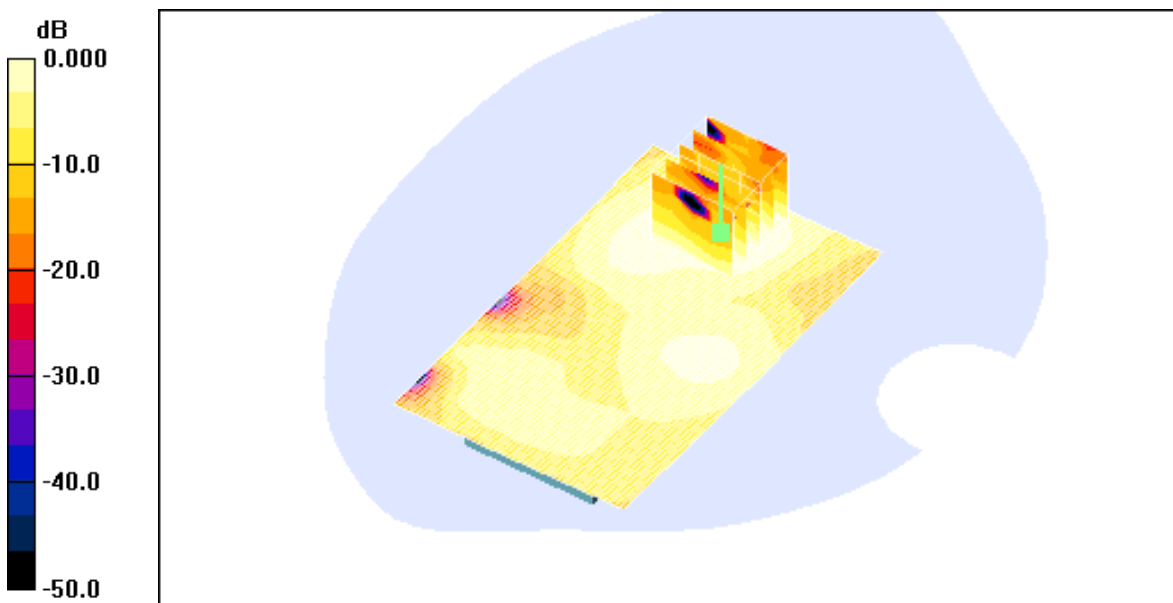

Test Laboratory: HCT CO., LTD  
EUT Type: Cellular/PCS WCDMA/GSM/EDGE Phone with WLAN, Bluetooth & FM Transmitter  
GPRS Class 12 and GPRS mode class B(GPRS and GSM, but not simultaneously)  
Liquid Temperature: 21.2 °C  
Ambient Temperature: 21.4 °C  
Test Date: Jun.17, 2009

**DUT: BL40f; Type: Bar; Serial: #1**

Communication System: GSM 850; Frequency: 836.6 MHz; Duty Cycle: 1:8.3  
Medium parameters used (interpolated):  $f = 836.6$  MHz;  $\sigma = 0.867$  mho/m;  $\epsilon_r = 42.6$ ;  $\rho = 1000$  kg/m<sup>3</sup>  
Phantom section: Left Section ; Measurement SW: DASY4, V4.7 Build 80; Postprocessing SW: SEMCAD, V1.8 Build 176

## DASY4 Configuration:

- Probe: ET3DV6 - SN1609; ConvF(6.25, 6.25, 6.25); Calibrated: 2009-03-17
- Sensor-Surface: 4mm (Mechanical Surface Detection)
- Electronics: DAE4 Sn869; Calibrated: 2008-09-03
- Phantom: 835/900 Phantom ; Type: SAM

**Left touch 190/Area Scan (51x101x1):** Measurement grid: dx=15mm, dy=15mm

[Info: Interpolated medium parameters used for SAR evaluation.](#)

Maximum value of SAR (interpolated) = 0.462 mW/g

**Left touch 190/Zoom Scan (5x5x7)/Cube 0:** Measurement grid: dx=8mm, dy=8mm, dz=5mm

Reference Value = 9.66 V/m; Power Drift = -0.786 dB

Peak SAR (extrapolated) = 0.550 W/kg

**SAR(1 g) = 0.417 mW/g; SAR(10 g) = 0.303 mW/g**

[Info: Interpolated medium parameters used for SAR evaluation.](#)

Maximum value of SAR (measured) = 0.435 mW/g

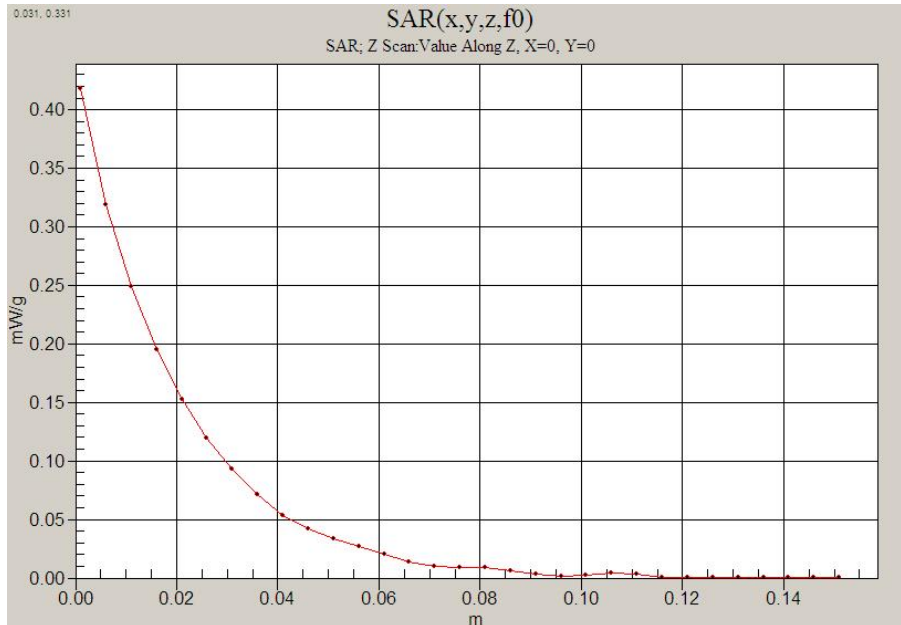

Test Laboratory: HCT CO., LTD  
EUT Type: Cellular/PCS WCDMA/GSM/EDGE Phone with WLAN, Bluetooth & FM Transmitter  
GPRS Class 12 and GPRS mode class B(GPRS and GSM, but not simultaneously)  
Liquid Temperature: 21.2 °C  
Ambient Temperature: 21.4 °C  
Test Date: Jun.17, 2009

**DUT: BL40f; Type: Bar; Serial: #1**

Communication System: GSM 850; Frequency: 836.6 MHz; Duty Cycle: 1:4.15  
Medium parameters used (interpolated):  $f = 836.6$  MHz;  $\sigma = 0.992$  mho/m;  $\epsilon_r = 54.1$ ;  $\rho = 1000$  kg/m<sup>3</sup>  
Phantom section: Flat Section ; Measurement SW: DASY4, V4.7 Build 80; Postprocessing SW: SEMCAD, V1.8 Build 176

## DASY4 Configuration:

- Probe: ET3DV6 - SN1609; ConvF(6.08, 6.08, 6.08); Calibrated: 2009-03-17
- Sensor-Surface: 4mm (Mechanical Surface Detection)
- Electronics: DAE4 Sn869; Calibrated: 2008-09-03
- Phantom: 835/900 Phantom ; Type: SAM

**Body 190/Area Scan (51x101x1):** Measurement grid: dx=15mm, dy=15mm

[Info: Interpolated medium parameters used for SAR evaluation.](#)

Maximum value of SAR (interpolated) = 1.14 mW/g

**Body 190/Zoom Scan (5x5x7)/Cube 0:** Measurement grid: dx=8mm, dy=8mm, dz=5mm

Reference Value = 27.4 V/m; Power Drift = 0.035 dB

Peak SAR (extrapolated) = 1.42 W/kg

**SAR(1 g) = 1.08 mW/g; SAR(10 g) = 0.789 mW/g**

[Info: Interpolated medium parameters used for SAR evaluation.](#)

Maximum value of SAR (measured) = 1.15 mW/g

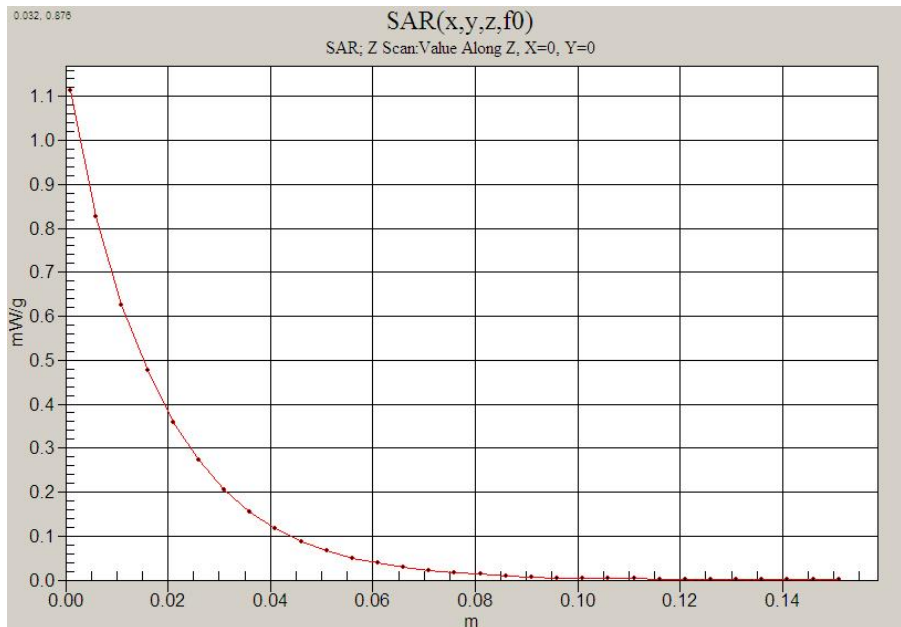

Test Laboratory: HCT CO., LTD  
EUT Type: Cellular/PCS WCDMA/GSM/EDGE Phone with WLAN, Bluetooth & FM Transmitter  
GPRS Class 12 and GPRS mode class B(GPRS and GSM, but not simultaneously)  
Liquid Temperature: 21.2 °C  
Ambient Temperature: 21.4 °C  
Test Date: Jun.17, 2009

**DUT: BL40f; Type: Bar; Serial: #1**

Communication System: GSM 1900; Frequency: 1880 MHz;Duty Cycle: 1:8.3  
Medium parameters used:  $f = 1880$  MHz;  $\sigma = 1.45$  mho/m;  $\epsilon_r = 40.4$ ;  $\rho = 1000$  kg/m<sup>3</sup>  
Phantom section: Left Section ; Measurement SW: DASY4, V4.7 Build 80; Postprocessing SW: SEMCAD, V1.8 Build 176

## DASY4 Configuration:

- Probe: ET3DV6 - SN1609; ConvF(5.12, 5.12, 5.12); Calibrated: 2009-03-17
- Sensor-Surface: 4mm (Mechanical Surface Detection)
- Electronics: DAE4 Sn869; Calibrated: 2008-09-03
- Phantom: 1800/1900 Phantom; Type: SAM

**Left touch 661/Area Scan (51x101x1):** Measurement grid: dx=15mm, dy=15mm  
Maximum value of SAR (interpolated) = 0.195 mW/g

**Left touch 661/Zoom Scan (5x5x7)/Cube 0:** Measurement grid: dx=8mm, dy=8mm, dz=5mm  
Reference Value = 7.65 V/m; Power Drift = -0.163 dB  
Peak SAR (extrapolated) = 0.302 W/kg  
**SAR(1 g) = 0.191 mW/g; SAR(10 g) = 0.114 mW/g**  
Maximum value of SAR (measured) = 0.216 mW/g

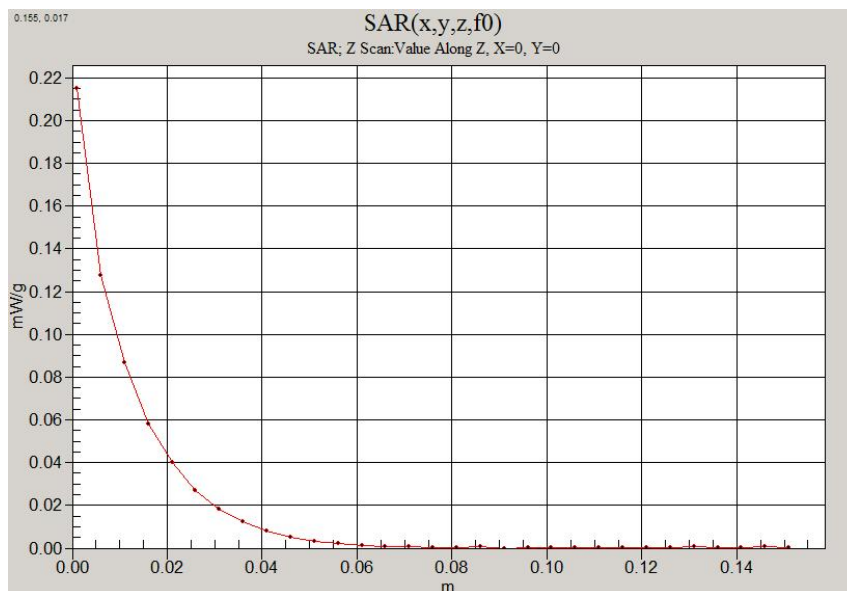

Test Laboratory: HCT CO., LTD  
EUT Type: Cellular/PCS WCDMA/GSM/EDGE Phone with WLAN, Bluetooth & FM Transmitter  
GPRS Class 12 and GPRS mode class B(GPRS and GSM, but not simultaneously)  
Liquid Temperature: 21.2 °C  
Ambient Temperature: 21.4 °C  
Test Date: Jun.17, 2009

**DUT: BL40f; Type: Bar; Serial: #1**

Communication System: GSM 1900; Frequency: 1880 MHz; Duty Cycle: 1:2.075  
Medium parameters used:  $f = 1880$  MHz;  $\sigma = 1.5$  mho/m;  $\epsilon_r = 52.1$ ;  $\rho = 1000$  kg/m<sup>3</sup>  
Phantom section: Flat Section ; Measurement SW: DASY4, V4.7 Build 80; Postprocessing SW: SEMCAD, V1.8 Build 176

## DASY4 Configuration:

- Probe: ET3DV6 - SN1609; ConvF(4.61, 4.61, 4.61); Calibrated: 2009-03-17
- Sensor-Surface: 4mm (Mechanical Surface Detection)
- Electronics: DAE4 Sn869; Calibrated: 2008-09-03
- Phantom: 1800/1900 Phantom; Type: SAM

**Body 661/Area Scan (51x101x1):** Measurement grid: dx=15mm, dy=15mm

Maximum value of SAR (interpolated) = 0.794 mW/g

**Body 661/Zoom Scan (5x5x7)/Cube 0:** Measurement grid: dx=8mm, dy=8mm, dz=5mm

Reference Value = 5.09 V/m; Power Drift = -0.063 dB

Peak SAR (extrapolated) = 1.29 W/kg

**SAR(1 g) = 0.744 mW/g; SAR(10 g) = 0.458 mW/g**

Maximum value of SAR (measured) = 0.801 mW/g

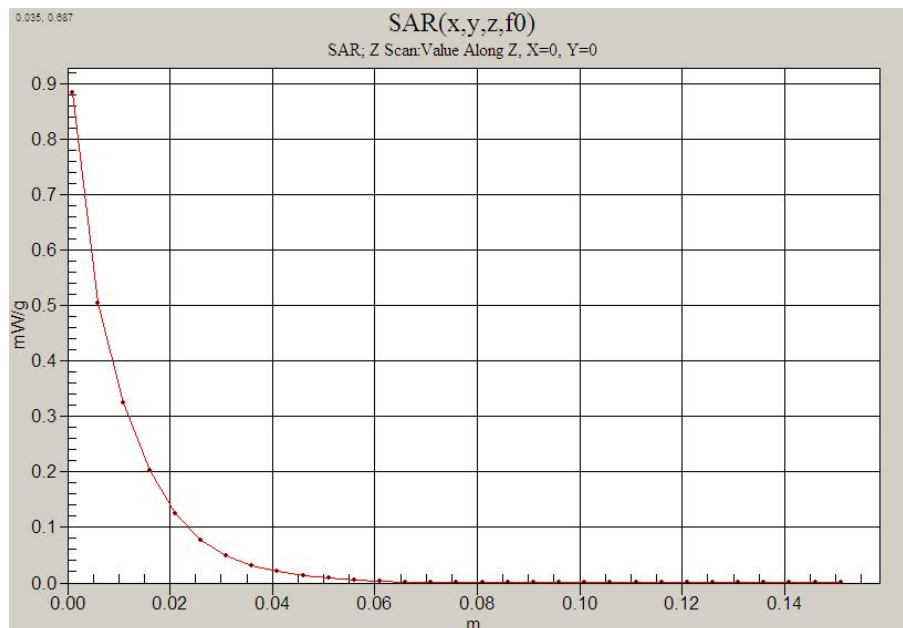

Test Laboratory: HCT CO., LTD  
 EUT Type: Cellular/PCS WCDMA/GSM/EDGE Phone with WLAN, Bluetooth & FM Transmitter  
 GPRS Class 12 and GPRS mode class B(GPRS and GSM, but not simultaneously)  
 Liquid Temperature: 21.3 °C  
 Ambient Temperature: 21.5 °C  
 Test Date: Jun.18, 2009

**DUT: BL40f; Type: Bar; Serial: #1**

Communication System: WCDMA850; Frequency: 836.6 MHz; Duty Cycle: 1:1  
 Medium parameters used (interpolated):  $f = 836.6$  MHz;  $\sigma = 0.867$  mho/m;  $\epsilon_r = 42.6$ ;  $\rho = 1000$  kg/m<sup>3</sup>  
 Phantom section: Left Section ; Measurement SW: DASY4, V4.7 Build 80; Postprocessing SW: SEMCAD, V1.8 Build 176

DASY4 Configuration:

- Probe: ET3DV6 - SN1609; ConvF(6.25, 6.25, 6.25); Calibrated: 2009-03-17
- Sensor-Surface: 4mm (Mechanical Surface Detection)
- Electronics: DAE4 Sn869; Calibrated: 2008-09-03
- Phantom: 835/900 Phantom ; Type: SAM

**Left touch 4183/Area Scan (51x101x1):** Measurement grid: dx=15mm, dy=15mm

[Info: Interpolated medium parameters used for SAR evaluation.](#)

Maximum value of SAR (interpolated) = 0.433 mW/g

**Left touch 4183/Zoom Scan (5x5x7)/Cube 0:** Measurement grid: dx=8mm, dy=8mm, dz=5mm

Reference Value = 8.69 V/m; Power Drift = -0.658 dB

Peak SAR (extrapolated) = 0.505 W/kg

**SAR(1 g) = 0.378 mW/g; SAR(10 g) = 0.272 mW/g**

[Info: Interpolated medium parameters used for SAR evaluation.](#)

Maximum value of SAR (measured) = 0.393 mW/g

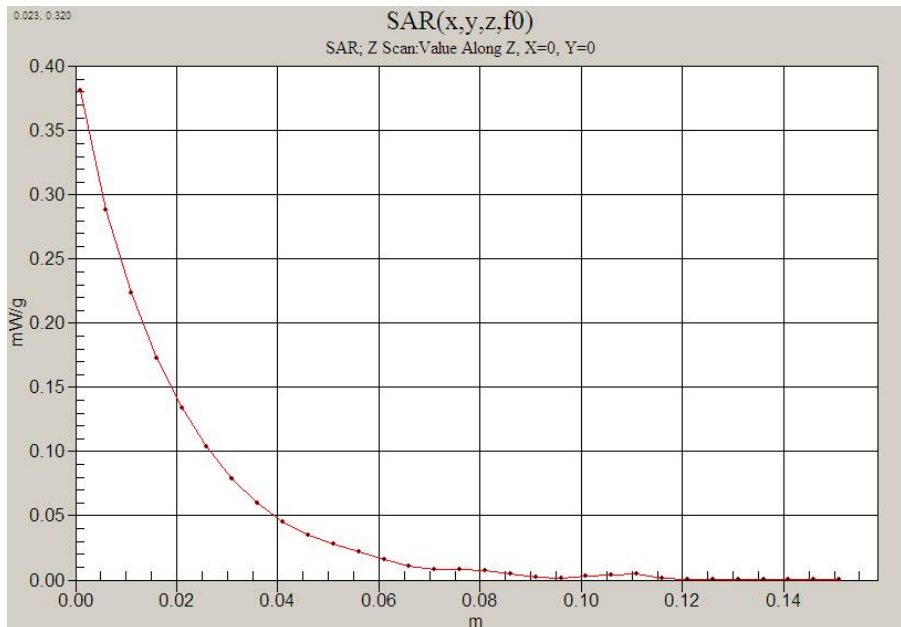

Test Laboratory: HCT CO., LTD  
 EUT Type: Cellular/PCS WCDMA/GSM/EDGE Phone with WLAN, Bluetooth & FM Transmitter  
 GPRS Class 12 and GPRS mode class B(GPRS and GSM, but not simultaneously)  
 Liquid Temperature: 21.3 °C  
 Ambient Temperature: 21.5 °C  
 Test Date: Jun.18, 2009

**DUT: BL40f; Type: Bar; Serial: #1**

Communication System: WCDMA850; Frequency: 836.6 MHz; Duty Cycle: 1:1  
 Medium parameters used (interpolated):  $f = 836.6 \text{ MHz}$ ;  $\sigma = 0.992 \text{ mho/m}$ ;  $\epsilon_r = 54.1$ ;  $\rho = 1000 \text{ kg/m}^3$   
 Phantom section: Flat Section ; Measurement SW: DASY4, V4.7 Build 80; Postprocessing SW: SEMCAD, V1.8 Build 176

DASY4 Configuration:

- Probe: ET3DV6 - SN1609; ConvF(6.08, 6.08, 6.08); Calibrated: 2009-03-17
- Sensor-Surface: 4mm (Mechanical Surface Detection)
- Electronics: DAE4 Sn869; Calibrated: 2008-09-03
- Phantom: 835/900 Phantom ; Type: SAM

**Body 4183/Area Scan (51x101x1):** Measurement grid: dx=15mm, dy=15mm

[Info: Interpolated medium parameters used for SAR evaluation.](#)

Maximum value of SAR (interpolated) = 0.731 mW/g

**Body 4183/Zoom Scan (5x5x7)/Cube 0:** Measurement grid: dx=8mm, dy=8mm, dz=5mm

Reference Value = 20.6 V/m; Power Drift = 0.207 dB

Peak SAR (extrapolated) = 0.883 W/kg

**SAR(1 g) = 0.686 mW/g; SAR(10 g) = 0.504 mW/g**

[Info: Interpolated medium parameters used for SAR evaluation.](#)

Maximum value of SAR (measured) = 0.724 mW/g

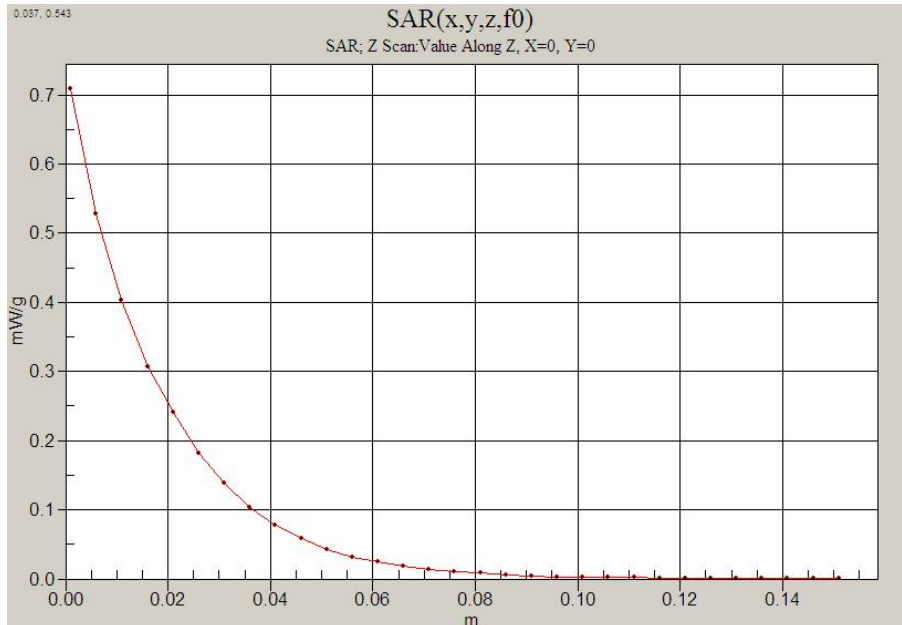

## Attachment 2. – Dipole Validation Plots

## ■ Validation Data (835 MHz Head)

Test Laboratory: HCT CO., LTD  
Input Power 100 mW (20 dBm)  
Liquid Temp: 21.2 °C  
Test Date: Jun.17, 2009

**DUT: Dipole 835 MHz; Type: D835V2; Serial: D835V2 – SN:441**

Communication System: CW; Frequency: 835 MHz; Duty Cycle: 1:1  
Medium parameters used:  $f = 835$  MHz;  $\sigma = 0.866$  mho/m;  $\epsilon_r = 42.6$ ;  $\rho = 1000$  kg/m<sup>3</sup>  
Phantom section: Flat Section ; Measurement SW: DASY4, V4.7 Build 80; Postprocessing SW: SEMCAD, V1.8 Build 176

DASY4 Configuration:

- Probe: ET3DV6 – SN1609; ConvF(6.25, 6.25, 6.25); Calibrated: 2009-03-17
- Sensor-Surface: 4mm (Mechanical Surface Detection)
- Electronics: DAE4 Sn869; Calibrated: 2008-09-03
- Phantom: SAM 835/900 MHz; Type: SAM

**Validation 835MHz/Area Scan (61x61x1):** Measurement grid: dx=15mm, dy=15mm  
Maximum value of SAR (interpolated) = 1.02 mW/g

**Validation 835MHz/Zoom Scan (5x5x7)/Cube 0:** Measurement grid: dx=8mm, dy=8mm, dz=5mm  
Reference Value = 35.1 V/m; Power Drift = 0.031 dB  
Peak SAR (extrapolated) = 1.46 W/kg  
**SAR(1 g) = 0.976 mW/g; SAR(10 g) = 0.636 mW/g**  
Maximum value of SAR (measured) = 1.05 mW/g

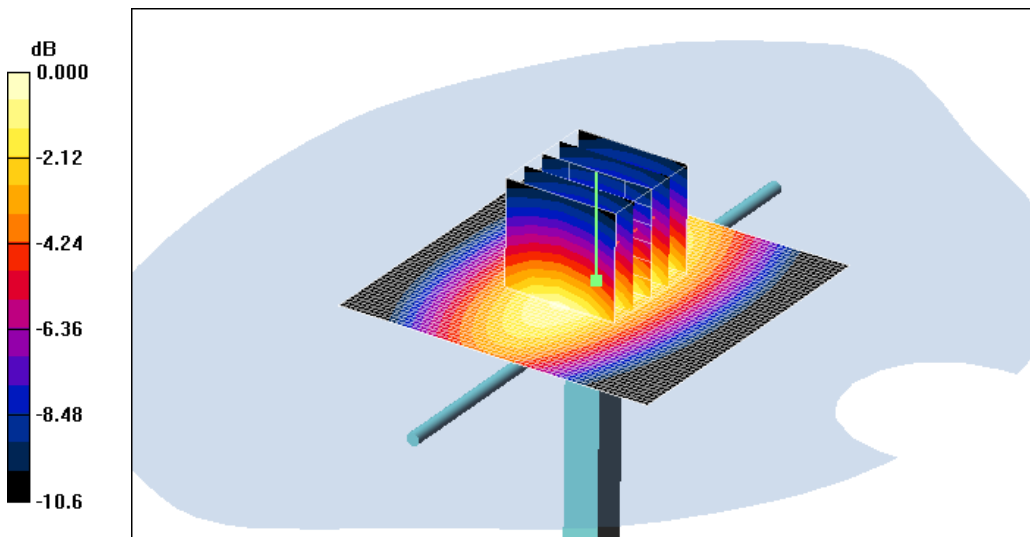

## ■ Validation Data (1900 MHz Head)

Test Laboratory: HCT CO., LTD  
Input Power 100 mW (20 dBm)  
Liquid Temp: 21.3 °C  
Test Date: Jun.18, 2009

**DUT: Dipole 1900 MHz; Type: D1900V2; Serial: D1900V2 – SN:5d032**

Communication System: CW; Frequency: 1900 MHz; Duty Cycle: 1:1  
Medium parameters used:  $f = 1900$  MHz;  $\sigma = 1.46$  mho/m;  $\epsilon_r = 40.2$ ;  $\rho = 1000$  kg/m<sup>3</sup>  
Phantom section: Flat Section ; Measurement SW: DASY4, V4.7 Build 80; Postprocessing SW: SEMCAD, V1.8 Build 176

DASY4 Configuration:

- Probe: ET3DV6 – SN1609; ConvF(5.12, 5.12, 5.12); Calibrated: 2009-03-17
- Sensor-Surface: 4mm (Mechanical Surface Detection)
- Electronics: DAE4 Sn869; Calibrated: 2008-09-03
- Phantom: SAM 1800/1900 MHz; Type: SAM

**Dipole 1900MHz Validation/Area Scan (61x61x1):** Measurement grid: dx=15mm, dy=15mm  
Maximum value of SAR (interpolated) = 4.70 mW/g

**Dipole 1900MHz Validation/Zoom Scan (5x5x7)/Cube 0:** Measurement grid: dx=8mm, dy=8mm, dz=5mm  
Reference Value = 57.9 V/m; Power Drift = -0.085 dB  
Peak SAR (extrapolated) = 6.68 W/kg  
**SAR(1 g) = 3.86 mW/g; SAR(10 g) = 2.01 mW/g**  
Maximum value of SAR (measured) = 4.29 mW/g

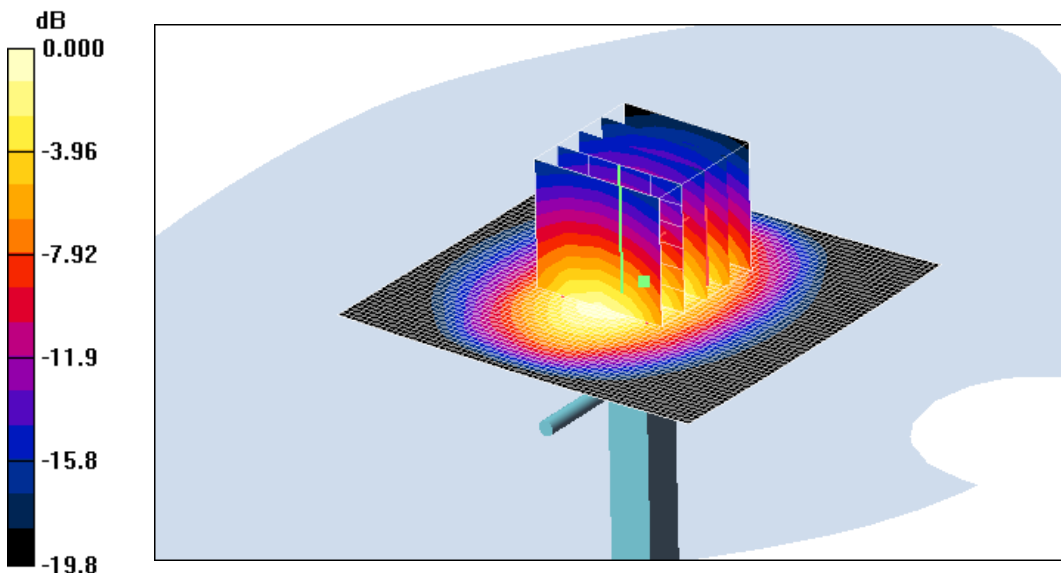

0 dB = 4.29mW/g

## ■ Validation Data (2450 MHz Head)

Test Laboratory: HCT CO., LTD  
Input Power 100 mW (20 dBm)  
Liquid Temp: 21.3 °C  
Test Date: Jul.31, 2009

**DUT: Dipole 2450 MHz; Type: D2450V2; Serial: D2450V2 – SN:743**

Communication System: CW; Frequency: 2450 MHz; Duty Cycle: 1:1  
Medium parameters used:  $f = 2450$  MHz;  $\sigma = 1.84$  mho/m;  $\epsilon_r = 39.7$ ;  $\rho = 1000$  kg/m<sup>3</sup>  
Phantom section: Flat Section ; Measurement SW: DASY4, V4.7 Build 71; Postprocessing SW: SEMCAD, V1.8 Build 176

DASY4 Configuration:

- Probe: ET3DV6 – SN1609; ConvF(4.54, 4.54, 4.54); Calibrated: 2009-03-17
- Sensor-Surface: 4mm (Mechanical Surface Detection)
- Electronics: DAE4 Sn869; Calibrated: 2008-09-03
- Phantom: SAM 1800/1900 MHz; Type: SAM

**Validation 2450MHz/Area Scan (61x61x1):** Measurement grid: dx=15mm, dy=15mm  
Maximum value of SAR (interpolated) = 6.38 mW/g

**Validation 2450MHz/Zoom Scan (5x5x7)/Cube 0:** Measurement grid: dx=8mm, dy=8mm, dz=5mm  
Reference Value = 60.4 V/m; Power Drift = -0.124 dB  
Peak SAR (extrapolated) = 11.9 W/kg  
**SAR(1 g) = 5.28 mW/g; SAR(10 g) = 2.43 mW/g**  
Maximum value of SAR (measured) = 5.78 mW/g

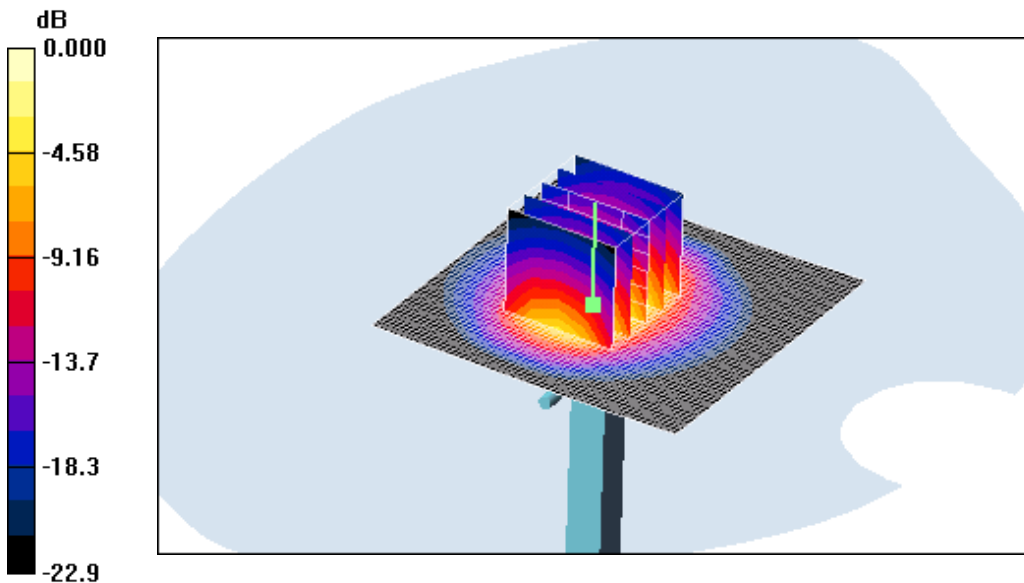

0 dB = 5.78mW/g

## ■ Validation Data (2450 MHz Head)

Test Laboratory: HCT CO., LTD  
Input Power 100 mW (20 dBm)  
Liquid Temp: 21.3 °C  
Test Date: Jul.31, 2009

**DUT: Dipole 2450 MHz; Type: D2450V2; Serial: D2450V2 – SN:743**

Communication System: CW; Frequency: 2450 MHz; Duty Cycle: 1:1  
Medium parameters used:  $f = 2450$  MHz;  $\sigma = 1.84$  mho/m;  $\epsilon_r = 39.7$ ;  $\rho = 1000$  kg/m<sup>3</sup>  
Phantom section: Flat Section ; Measurement SW: DASY4, V4.7 Build 71; Postprocessing SW: SEMCAD, V1.8 Build 176

DASY4 Configuration:

- Probe: ET3DV6 – SN1609; ConvF(4.54, 4.54, 4.54); Calibrated: 2009-03-17
- Sensor-Surface: 4mm (Mechanical Surface Detection)
- Electronics: DAE4 Sn869; Calibrated: 2008-09-03
- Phantom: SAM 1800/1900 MHz; Type: SAM

**Validation 2450MHz/Area Scan (61x61x1):** Measurement grid: dx=15mm, dy=15mm  
Maximum value of SAR (interpolated) = 6.38 mW/g

**Validation 2450MHz/Zoom Scan (5x5x7)/Cube 0:** Measurement grid: dx=8mm, dy=8mm, dz=5mm  
Reference Value = 60.4 V/m; Power Drift = -0.124 dB  
Peak SAR (extrapolated) = 11.9 W/kg  
**SAR(1 g) = 5.28 mW/g; SAR(10 g) = 2.43 mW/g**  
Maximum value of SAR (measured) = 5.78 mW/g

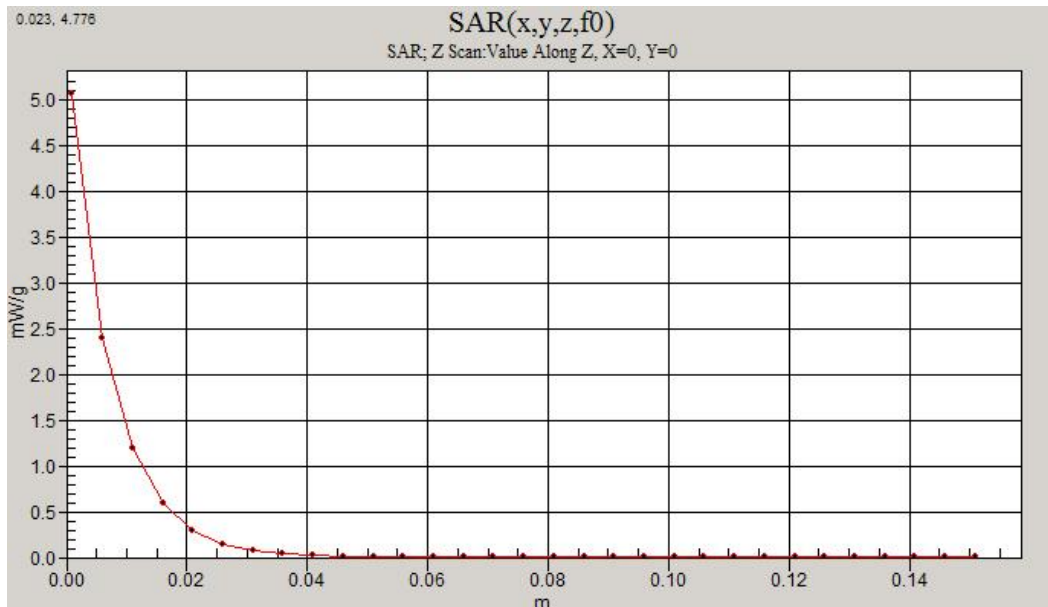

## ■ Dielectric Parameter (835 MHz Head)

Title BL40f  
 SubTitle GSM850(Head)  
 Test Date Jun.17, 2009

Frequency	e'	e''
800000000	43.2754	18.7685
805000000	43.2163	18.7060
810000000	43.0598	18.6771
815000000	42.9880	18.6948
820000000	42.8625	18.6691
825000000	42.7674	18.6885
830000000	42.6959	18.6380
835000000	42.6007	18.6475
840000000	42.5419	18.6153
845000000	42.4596	18.6425
850000000	42.3912	18.6242
855000000	42.3778	18.6314
860000000	42.3454	18.6594
865000000	42.3041	18.6540
870000000	42.2672	18.6779
875000000	42.3022	18.6853
880000000	42.2416	18.6756
885000000	42.2390	18.6887
890000000	42.2144	18.6933
895000000	42.1502	18.6801
900000000	42.1099	18.6449

**■ Dielectric Parameter (835 MHz Body)**

Title BL40f  
SubTitle GSM850(Body)  
Test Date Jun.17, 2009

Frequency	e'	e''
800000000	54.4349	21.4788
805000000	54.4210	21.4451
810000000	54.3185	21.4147
815000000	54.2402	21.4158
820000000	54.2082	21.4172
825000000	54.1364	21.3828
830000000	54.1399	21.3992
835000000	54.0985	21.3211
840000000	54.0507	21.3285
845000000	53.9441	21.2921
850000000	53.9089	21.2679
855000000	53.8550	21.2347
860000000	53.7558	21.2081
865000000	53.7211	21.1632
870000000	53.6891	21.1659
875000000	53.5994	21.1264
880000000	53.5430	21.1015
885000000	53.4861	21.0454
890000000	53.3993	21.0594
895000000	53.3791	21.0792
900000000	53.3566	21.0370

**■ Dielectric Parameter (1900 MHz Head)**

Title BL40f  
SubTitle GSM1900(Head)  
Test Date Jun.18, 2009

Frequency	e'	e''
1850000000	40.5821	13.9035
1855000000	40.5952	13.9051
1860000000	40.5763	13.9089
1865000000	40.5824	13.9180
1870000000	40.5292	13.9103
1875000000	40.4899	13.9001
1880000000	40.4470	13.8558
1885000000	40.3830	13.8347
1890000000	40.3043	13.8325
1895000000	40.2662	13.8133
1900000000	40.1703	13.8018
1905000000	40.1077	13.7810
1910000000	40.0281	13.8256
1915000000	39.9796	13.7932
1920000000	39.9599	13.8409
1925000000	39.8894	13.8472
1930000000	39.9006	13.9136
1935000000	39.9095	13.9396
1940000000	39.9289	14.0034
1945000000	39.9527	14.0372
1950000000	39.9815	14.0555

**■ Dielectric Parameter (1900 MHz Body)**

Title BL40f  
SubTitle GSM1900(Body)  
Test Date Jun.18, 2009

Frequency	e'	e''
1850000000	52.2510	14.2986
1855000000	52.2056	14.3244
1860000000	52.2211	14.3328
1865000000	52.1712	14.3809
1870000000	52.1223	14.3886
1875000000	52.1230	14.3707
1880000000	52.0885	14.3734
1885000000	52.0402	14.3561
1890000000	51.9786	14.3797
1895000000	51.9600	14.4188
1900000000	51.9442	14.4125
1905000000	51.8583	14.4550
1910000000	51.8955	14.5265
1915000000	51.8650	14.5697
1920000000	51.8727	14.6069
1925000000	51.8933	14.6539
1930000000	51.9184	14.6932
1935000000	51.9801	14.7169
1940000000	51.9301	14.7279
1945000000	51.9983	14.7379
1950000000	52.0218	14.7459

**■ Dielectric Parameter (2450 MHz Head)**

Title BL40f  
SubTitle 2450 MHz(Head)  
Test Date Jul.31, 2009

Frequency	e'	e''
2400000000.0000	39.9013	13.2712
2405000000.0000	39.8881	13.2722
2410000000.0000	39.8627	13.2950
2415000000.0000	39.8186	13.3056
2420000000.0000	39.8306	13.3417
2425000000.0000	39.8132	13.3238
2430000000.0000	39.7760	13.3742
2435000000.0000	39.7513	13.3995
2440000000.0000	39.7333	13.4192
2445000000.0000	39.7018	13.4394
2450000000.0000	39.6906	13.4759
2455000000.0000	39.7080	13.4932
2460000000.0000	39.7026	13.5164
2465000000.0000	39.6801	13.5262
2470000000.0000	39.6168	13.5408
2475000000.0000	39.6027	13.5434
2480000000.0000	39.5900	13.5732
2485000000.0000	39.6006	13.6163
2490000000.0000	39.6920	13.6898
2495000000.0000	39.7065	13.7238
2500000000.0000	39.6999	13.7368

**■ Dielectric Parameter (2450 MHz Body)**

Title BL40f  
SubTitle 2450 MHz (Body)  
Test Date Jul.31, 2009

Frequency	e'	e''
2400000000.0000	52.0956	14.0176
2405000000.0000	52.0853	14.0334
2410000000.0000	52.0110	14.0547
2415000000.0000	51.9604	14.0765
2420000000.0000	51.9356	14.1186
2425000000.0000	51.9314	14.1351
2430000000.0000	51.8796	14.1819
2435000000.0000	51.8346	14.2277
2440000000.0000	51.8223	14.2249
2445000000.0000	51.7731	14.2843
2450000000.0000	51.7867	14.3279
2455000000.0000	51.7798	14.3639
2460000000.0000	51.7534	14.3724
2465000000.0000	51.7514	14.4290
2470000000.0000	51.7184	14.4613
2475000000.0000	51.6932	14.4462
2480000000.0000	51.7243	14.5098
2485000000.0000	51.6964	14.5362
2490000000.0000	51.6994	14.5305
2495000000.0000	51.6800	14.5539
2500000000.0000	51.6655	14.5750

## Attachment 3. – Probe Calibration Data

**Calibration Laboratory of  
Schmid & Partner  
Engineering AG**  
Zeughausstrasse 43, 8004 Zurich, Switzerland



**S** Schweizerischer Kalibrierdienst  
**S** Service suisse d'étalonnage  
**S** Servizio svizzero di taratura  
**S** Swiss Calibration Service

Accredited by the Swiss Accreditation Service (SAS)  
The Swiss Accreditation Service is one of the signatories to the EA  
Multilateral Agreement for the recognition of calibration certificates

Accreditation No.: **SCS 108**

Client **HCT (Dymstec)**

Certificate No: **ET3-1609\_Mar09**

**CALIBRATION CERTIFICATE**

Object: **ET3DV6 - SN:1609**

Calibration procedure(s): **QA CAL-01.v6, QA CAL-12.v5 and QA CAL-23.v3  
Calibration procedure for dosimetric E-field probes**

Calibration date: **March 17, 2009**

Condition of the calibrated item: **In Tolerance**

This calibration certificate documents the traceability to national standards, which realize the physical units of measurements (SI).  
The measurements and the uncertainties with confidence probability are given on the following pages and are part of the certificate.

All calibrations have been conducted in the closed laboratory facility: environment temperature (22 ± 3)\*°C and humidity < 70%.

Calibration Equipment used (M&TE critical for calibration)

Primary Standards	ID #	Cal Date (Certificate No.)	Scheduled Calibration
Power meter E4419B	GB41293874	1-Apr-08 (No. 217-00788)	Apr-09
Power sensor E4412A	MY41495277	1-Apr-08 (No. 217-00788)	Apr-09
Power sensor E4412A	MY41498087	1-Apr-08 (No. 217-00788)	Apr-09
Reference 3 dB Attenuator	SN: S5054 (3c)	1-Jul-08 (No. 217-00865)	Jul-09
Reference 20 dB Attenuator	SN: S5086 (20b)	31-Mar-08 (No. 217-00787)	Apr-09
Reference 30 dB Attenuator	SN: S5129 (30b)	1-Jul-08 (No. 217-00866)	Jul-09
Reference Probe ES3DV2	SN: 3013	2-Jan-09 (No. ES3-3013_Jan09)	Jan-10
DAE4	SN: 660	9-Sep-08 (No. DAE4-660_Sep08)	Sep-09

Secondary Standards	ID #	Check Date (in house)	Scheduled Check
RF generator HP 8848C	US3642U01700	4-Aug-99 (in house check Oct-07)	In house check: Oct-08
Network Analyzer HP 8753E	US37390585	18-Oct-01 (in house check Oct-08)	In house check: Oct-08

	Name	Function	Signature
Calibrated by:	Marcel Fehr	Laboratory Technician	
Approved by:	Katja Pokovic	Technical Manager	

Issued: March 17, 2009

This calibration certificate shall not be reproduced except in full without written approval of the laboratory.

**Calibration Laboratory of  
Schmid & Partner  
Engineering AG**  
Zeughausstrasse 43, 8004 Zurich, Switzerland



**S** Schweizerischer Kalibrierdienst  
**S** Service suisse d'étalonnage  
**C** Servizio svizzero di taratura  
**S** Swiss Calibration Service

Accredited by the Swiss Accreditation Service (SAS)  
The Swiss Accreditation Service is one of the signatories to the EA  
Multilateral Agreement for the recognition of calibration certificates

Accreditation No.: **SCS 108**

**Glossary:**

TSL tissue simulating liquid  
NORM<sub>x,y,z</sub> sensitivity in free space  
ConvF sensitivity in TSL / NORM<sub>x,y,z</sub>  
DCP diode compression point  
Polarization  $\varphi$   $\varphi$  rotation around probe axis  
Polarization  $\vartheta$   $\vartheta$  rotation around an axis that is in the plane normal to probe axis (at measurement center), i.e.,  $\vartheta = 0$  is normal to probe axis

**Calibration is Performed According to the Following Standards:**

- a) IEEE Std 1528-2003, "IEEE Recommended Practice for Determining the Peak Spatial-Averaged Specific Absorption Rate (SAR) in the Human Head from Wireless Communications Devices: Measurement Techniques", December 2003
- b) IEC 62209-1, "Procedure to measure the Specific Absorption Rate (SAR) for hand-held devices used in close proximity to the ear (frequency range of 300 MHz to 3 GHz)", February 2005

**Methods Applied and Interpretation of Parameters:**

- *NORM<sub>x,y,z</sub>*: Assessed for E-field polarization  $\vartheta = 0$  ( $f \leq 900$  MHz in TEM-cell;  $f > 1800$  MHz: R22 waveguide). *NORM<sub>x,y,z</sub>* are only intermediate values, i.e., the uncertainties of *NORM<sub>x,y,z</sub>* does not effect the  $E^2$ -field uncertainty inside TSL (see below *ConvF*).
- *NORM(f)<sub>x,y,z</sub> = NORM<sub>x,y,z</sub> \* frequency\_response* (see Frequency Response Chart). This linearization is implemented in DASY4 software versions later than 4.2. The uncertainty of the frequency response is included in the stated uncertainty of *ConvF*.
- *DCP<sub>x,y,z</sub>*: DCP are numerical linearization parameters assessed based on the data of power sweep (no uncertainty required). DCP does not depend on frequency nor media.
- *ConvF and Boundary Effect Parameters*: Assessed in flat phantom using E-field (or Temperature Transfer Standard for  $f \leq 800$  MHz) and inside waveguide using analytical field distributions based on power measurements for  $f > 800$  MHz. The same setups are used for assessment of the parameters applied for boundary compensation (alpha, depth) of which typical uncertainty values are given. These parameters are used in DASY4 software to improve probe accuracy close to the boundary. The sensitivity in TSL corresponds to *NORM<sub>x,y,z</sub> \* ConvF* whereby the uncertainty corresponds to that given for *ConvF*. A frequency dependent *ConvF* is used in DASY version 4.4 and higher which allows extending the validity from  $\pm 50$  MHz to  $\pm 100$  MHz.
- *Spherical isotropy (3D deviation from isotropy)*: in a field of low gradients realized using a flat phantom exposed by a patch antenna.
- *Sensor Offset*: The sensor offset corresponds to the offset of virtual measurement center from the probe tip (on probe axis). No tolerance required.

ET3DV6 SN:1609

March 17, 2009

# Probe ET3DV6

## SN:1609

Manufactured:	July 21, 2001
Last calibrated:	August 30, 2007
Recalibrated:	March 17, 2009

Calibrated for DASY Systems

(Note: non-compatible with DASY2 system!)

Certificate No: ET3-1609\_Mar09

Page 3 of 9

ET3DV6 SN:1609

March 17, 2009

**DASY - Parameters of Probe: ET3DV6 SN:1609**

Sensitivity in Free Space<sup>A</sup>

Diode Compression<sup>B</sup>

NormX	1.97 ± 10.1%	$\mu V/(V/m)^2$	DCP X	93 mV
NormY	1.87 ± 10.1%	$\mu V/(V/m)^2$	DCP Y	90 mV
NormZ	1.82 ± 10.1%	$\mu V/(V/m)^2$	DCP Z	93 mV

Sensitivity in Tissue Simulating Liquid (Conversion Factors)

Please see Page 8.

Boundary Effect

**TSL**                    **900 MHz**      **Typical SAR gradient: 5 % per mm**

Sensor Center to Phantom Surface Distance		<b>3.7 mm</b>	<b>4.7 mm</b>
SAR <sub>be</sub> [%]	Without Correction Algorithm	11.4	7.0
SAR <sub>be</sub> [%]	With Correction Algorithm	0.9	0.5

**TSL**                    **1750 MHz**      **Typical SAR gradient: 10 % per mm**

Sensor Center to Phantom Surface Distance		<b>3.7 mm</b>	<b>4.7 mm</b>
SAR <sub>be</sub> [%]	Without Correction Algorithm	13.8	9.5
SAR <sub>be</sub> [%]	With Correction Algorithm	0.9	0.6

Sensor Offset

Probe Tip to Sensor Center                    **2.7 mm**

The reported uncertainty of measurement is stated as the standard uncertainty of measurement multiplied by the coverage factor k=2, which for a normal distribution corresponds to a coverage probability of approximately 95%.

<sup>A</sup> The uncertainties of NormX,Y,Z do not affect the E<sup>2</sup>-field uncertainty inside TSL (see Page 8).

<sup>B</sup> Numerical linearization parameter: uncertainty not required

ET3DV6 SN:1609

March 17, 2009

### Frequency Response of E-Field

(TEM-Cell:ifi110 EXX, Waveguide: R22)

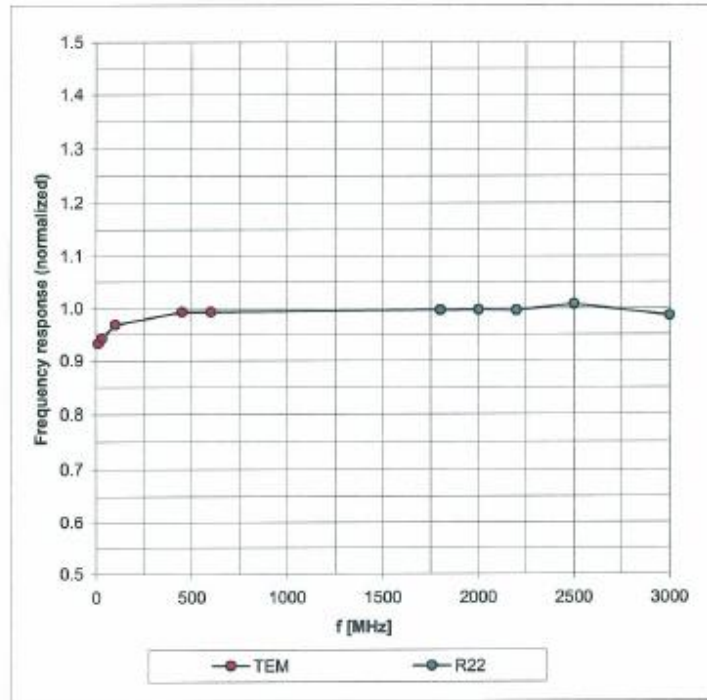

Uncertainty of Frequency Response of E-field:  $\pm 6.3\%$  (k=2)

ET3DV6 SN:1609

March 17, 2009

**Receiving Pattern ( $\phi$ ),  $\theta = 0^\circ$**

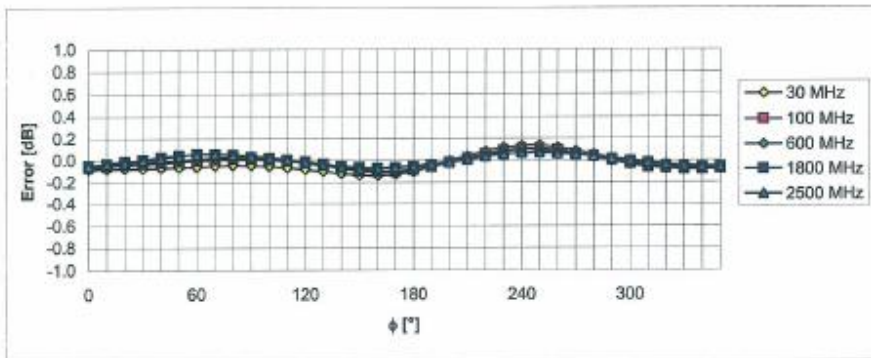
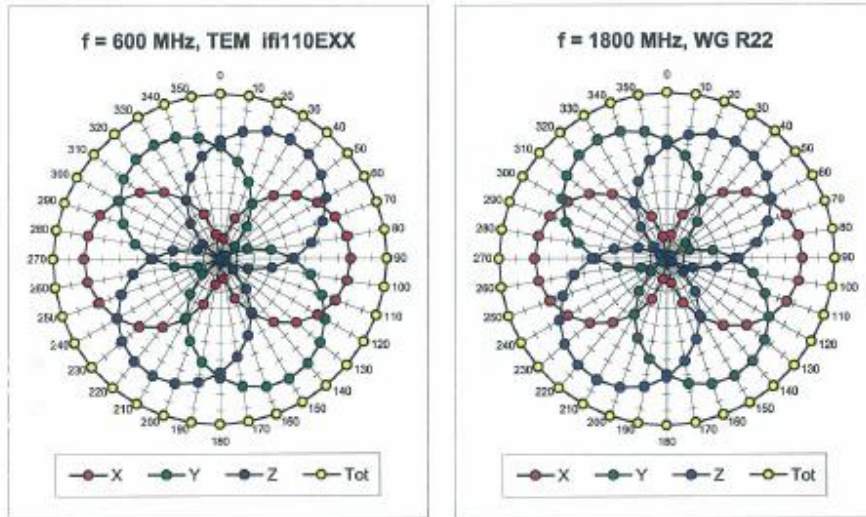

Uncertainty of Axial Isotropy Assessment:  $\pm 0.5\%$  ( $k=2$ )

ET3DV6 SN:1609

March 17, 2009

**Dynamic Range f(SAR<sub>head</sub>)**  
(Waveguide R22, f = 1800 MHz)

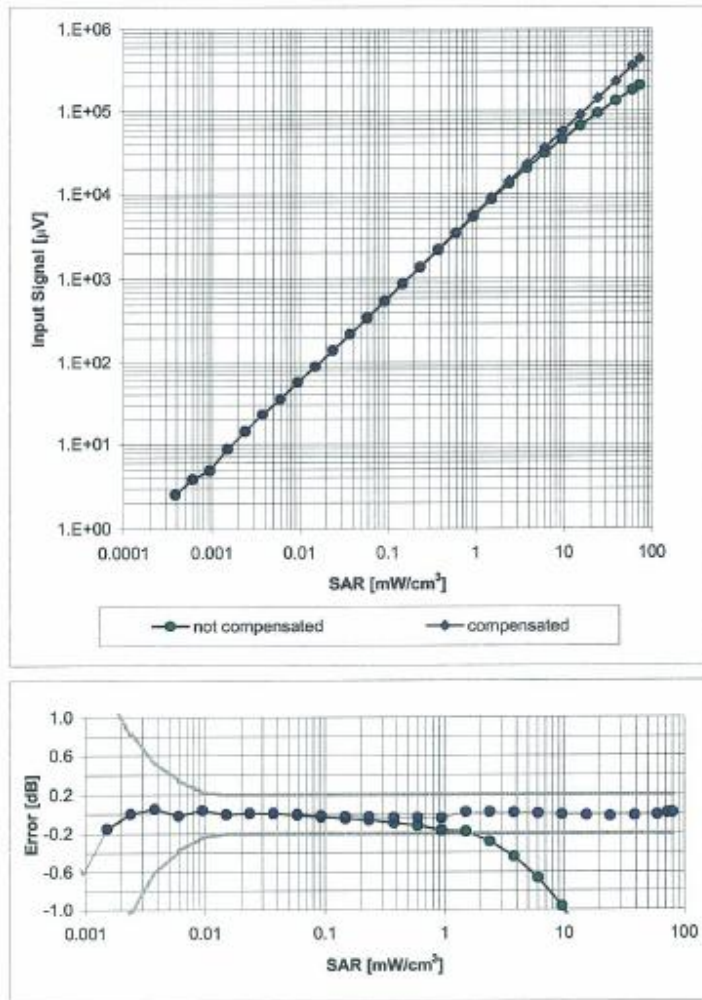

Uncertainty of Linearity Assessment: ± 0.6% (k=2)

ET3DV6 SN:1609

March 17, 2009

### Conversion Factor Assessment

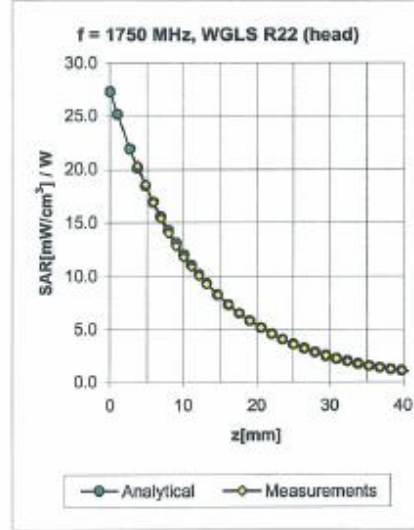
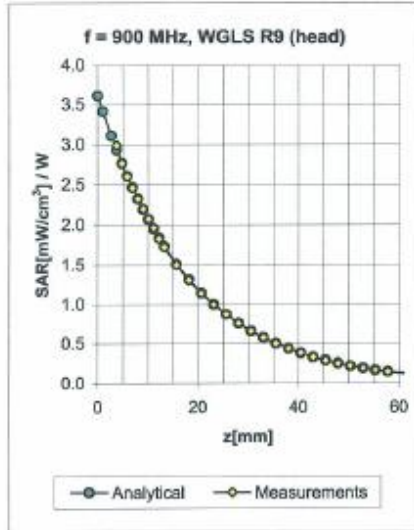

f [MHz]	Validity [MHz] <sup>c</sup>	TSL	Permittivity	Conductivity	Alpha	Depth	ConvF Uncertainty
450	± 50 / ± 100	Head	43.5 ± 5%	0.87 ± 5%	0.38	1.91	6.91 ± 13.3% (k=2)
835	± 50 / ± 100	Head	41.5 ± 5%	0.90 ± 5%	0.25	2.80	6.25 ± 11.0% (k=2)
900	± 50 / ± 100	Head	41.5 ± 5%	0.97 ± 5%	0.25	2.80	6.11 ± 11.0% (k=2)
1750	± 50 / ± 100	Head	40.1 ± 5%	1.37 ± 5%	0.39	3.57	5.39 ± 11.0% (k=2)
1900	± 50 / ± 100	Head	40.0 ± 5%	1.40 ± 5%	0.50	2.75	5.12 ± 11.0% (k=2)
1950	± 50 / ± 100	Head	40.0 ± 5%	1.40 ± 5%	0.55	2.52	5.01 ± 11.0% (k=2)
2450	± 50 / ± 100	Head	39.2 ± 5%	1.80 ± 5%	0.99	1.76	4.54 ± 11.0% (k=2)
450	± 50 / ± 100	Body	56.7 ± 5%	0.94 ± 5%	0.30	1.92	7.48 ± 13.3% (k=2)
835	± 50 / ± 100	Body	55.2 ± 5%	0.97 ± 5%	0.25	2.85	6.08 ± 11.0% (k=2)
1750	± 50 / ± 100	Body	53.4 ± 5%	1.49 ± 5%	0.77	3.05	4.89 ± 11.0% (k=2)
1900	± 50 / ± 100	Body	53.3 ± 5%	1.52 ± 5%	0.99	2.60	4.61 ± 11.0% (k=2)
2450	± 50 / ± 100	Body	52.7 ± 5%	1.95 ± 5%	0.99	1.78	4.00 ± 11.0% (k=2)

<sup>c</sup> The validity of ± 100 MHz only applies for DASY v4.4 and higher (see Page 2). The uncertainty is the RSS of the ConvF uncertainty at calibration frequency and the uncertainty for the indicated frequency band.

ET3DV6 SN:1609

March 17, 2009

### Deviation from Isotropy in HSL

Error ( $\phi, \theta$ ),  $f = 900$  MHz

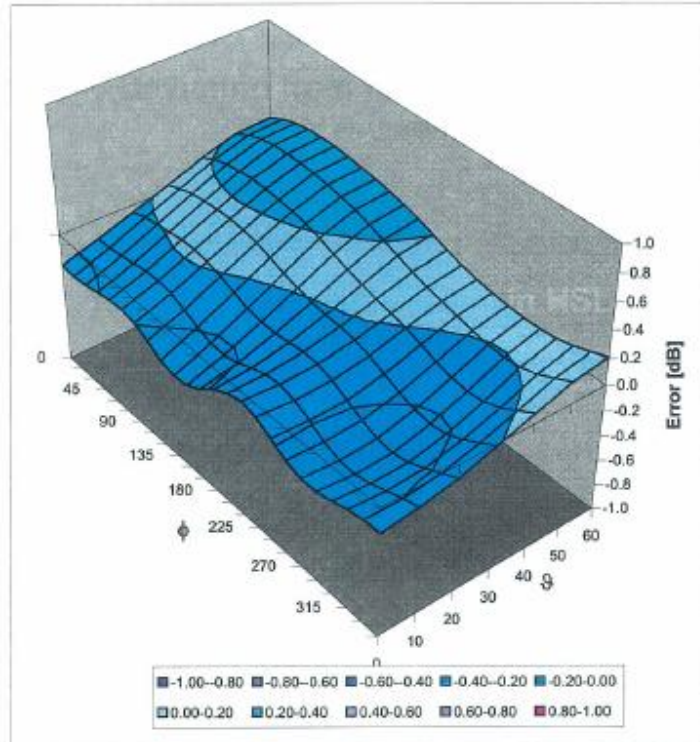

Uncertainty of Spherical Isotropy Assessment:  $\pm 2.6\%$  ( $k=2$ )

## Attachment 4. – Dipole Calibration Data

**Calibration Laboratory of  
Schmid & Partner  
Engineering AG**  
Zeughausstrasse 43, 8004 Zurich, Switzerland



**S** Schweizerischer Kalibrierdienst  
**C** Service suisse d'étalonnage  
**S** Servizio svizzero di taratura  
**S** Swiss Calibration Service

Accredited by the Swiss Accreditation Service (SAS)  
The Swiss Accreditation Service is one of the signatories to the EA  
Multilateral Agreement for the recognition of calibration certificates

Accreditation No.: **SCS 108**

Client **HTC (Dymstec)**

Certificate No: **D835V2-441\_May09**

**CALIBRATION CERTIFICATE**

Object **D835V2 - SN: 441**

Calibration procedure(s) **QA CAL-05.v7  
Calibration procedure for dipole validation kits**

Calibration date: **May 25, 2009**

Condition of the calibrated item **In Tolerance**

This calibration certificate documents the traceability to national standards, which realize the physical units of measurements (SI).  
The measurements and the uncertainties with confidence probability are given on the following pages and are part of the certificate.

All calibrations have been conducted in the closed laboratory facility: environment temperature (22 ± 3)°C and humidity < 70%.

Calibration Equipment used (M&TE critical for calibration)

Primary Standards	ID #	Cal Date (Certificate No.)	Scheduled Calibration
Power meter EPM-442A	GB37480704	08-Oct-08 (No. 217-00898)	Oct-09
Power sensor HP 8481A	US37292783	08-Oct-08 (No. 217-00898)	Oct-09
Reference 20 dB Attenuator	SN: 5086 (20g)	31-Mar-09 (No. 217-01025)	Mar-10
Type-N mismatch combination	SN: 5047.2 / 06327	31-Mar-09 (No. 217-01029)	Mar-10
Reference Probe ES3DV2	SN: 3025	30-Apr-09 (No. ES3-3025_Apr09)	Apr-10
DAE4	SN: 601	07-Mar-09 (No. DAE4-601_Mar09)	Mar-10
Secondary Standards	ID #	Check Date (in house)	Scheduled Check
Power sensor HP 8481A	MY41092317	18-Oct-02 (in house check Oct-07)	In house check: Oct-09
RF generator R&S SMT-06	100005	4-Aug-99 (in house check Oct-07)	In house check: Oct-09
Network Analyzer HP 8753E	US37390585 S4206	18-Oct-01 (in house check Oct-08)	In house check: Oct-09

Calibrated by:	Name Jeton Kastrati	Function Laboratory Technician	Signature 
Approved by:	Name Katja Pokovic	Function Technical Manager	Signature 

Issued: May 25, 2009

This calibration certificate shall not be reproduced except in full without written approval of the laboratory.

**Calibration Laboratory of**  
Schmid & Partner  
Engineering AG  
Zeughausstrasse 43, 8004 Zurich, Switzerland



**S** Schweizerischer Kalibrierdienst  
**C** Service suisse d'étalonnage  
**S** Servizio svizzero di taratura  
**S** Swiss Calibration Service

Accredited by the Swiss Accreditation Service (SAS)  
The Swiss Accreditation Service is one of the signatories to the EA  
Multilateral Agreement for the recognition of calibration certificates

Accreditation No.: **SCS 108**

**Glossary:**

TSL	tissue simulating liquid
ConvF	sensitivity in TSL / NORM x,y,z
N/A	not applicable or not measured

**Calibration is Performed According to the Following Standards:**

- IEEE Std 1528-2003, "IEEE Recommended Practice for Determining the Peak Spatial-Averaged Specific Absorption Rate (SAR) in the Human Head from Wireless Communications Devices: Measurement Techniques", December 2003
- IEC 62209-1, "Procedure to measure the Specific Absorption Rate (SAR) for hand-held devices used in close proximity to the ear (frequency range of 300 MHz to 3 GHz)", February 2005
- Federal Communications Commission Office of Engineering & Technology (FCC OET), "Evaluating Compliance with FCC Guidelines for Human Exposure to Radiofrequency Electromagnetic Fields; Additional Information for Evaluating Compliance of Mobile and Portable Devices with FCC Limits for Human Exposure to Radiofrequency Emissions", Supplement C (Edition 01-01) to Bulletin 65

**Additional Documentation:**

- DASY4/5 System Handbook

**Methods Applied and Interpretation of Parameters:**

- Measurement Conditions:* Further details are available from the Validation Report at the end of the certificate. All figures stated in the certificate are valid at the frequency indicated.
- Antenna Parameters with TSL:* The dipole is mounted with the spacer to position its feed point exactly below the center marking of the flat phantom section, with the arms oriented parallel to the body axis.
- Feed Point Impedance and Return Loss:* These parameters are measured with the dipole positioned under the liquid filled phantom. The impedance stated is transformed from the measurement at the SMA connector to the feed point. The Return Loss ensures low reflected power. No uncertainty required.
- Electrical Delay:* One-way delay between the SMA connector and the antenna feed point. No uncertainty required.
- SAR measured:* SAR measured at the stated antenna input power.
- SAR normalized:* SAR as measured, normalized to an input power of 1 W at the antenna connector.
- SAR for nominal TSL parameters:* The measured TSL parameters are used to calculate the nominal SAR result.

**Measurement Conditions**

DASY system configuration, as far as not given on page 1.

<b>DASY Version</b>	DASY5	V5.0
<b>Extrapolation</b>	Advanced Extrapolation	
<b>Phantom</b>	Modular Flat Phantom V4.9	
<b>Distance Dipole Center - TSL</b>	15 mm	with Spacer
<b>Zoom Scan Resolution</b>	dx, dy, dz = 5 mm	
<b>Frequency</b>	835 MHz $\pm$ 1 MHz	

**Head TSL parameters**

The following parameters and calculations were applied.

	<b>Temperature</b>	<b>Permittivity</b>	<b>Conductivity</b>
<b>Nominal Head TSL parameters</b>	22.0 °C	41.5	0.90 mho/m
<b>Measured Head TSL parameters</b>	(22.0 $\pm$ 0.2) °C	40.8 $\pm$ 6 %	0.89 mho/m $\pm$ 6 %
<b>Head TSL temperature during test</b>	(21.6 $\pm$ 0.2) °C	----	----

**SAR result with Head TSL**

<b>SAR averaged over 1 cm<sup>3</sup> (1 g) of Head TSL</b>	<b>Condition</b>	
SAR measured	250 mW input power	2.38 mW / g
SAR normalized	normalized to 1W	9.52 mW / g
SAR for nominal Head TSL parameters <sup>1</sup>	normalized to 1W	<b>9.56 mW / g <math>\pm</math> 17.0 % (k=2)</b>

<b>SAR averaged over 10 cm<sup>3</sup> (10 g) of Head TSL</b>	<b>condition</b>	
SAR measured	250 mW input power	1.56 mW / g
SAR normalized	normalized to 1W	6.24 mW / g
SAR for nominal Head TSL parameters <sup>1</sup>	normalized to 1W	<b>6.26 mW / g <math>\pm</math> 16.5 % (k=2)</b>

<sup>1</sup> Correction to nominal TSL parameters according to d), chapter "SAR Sensitivities"

**Appendix****Antenna Parameters with Head TSL**

Impedance, transformed to feed point	50.3 $\Omega$ - 7.4 j $\Omega$
Return Loss	- 22.7 dB

**General Antenna Parameters and Design**

Electrical Delay (one direction)	1.393 ns
----------------------------------	----------

After long term use with 100W radiated power, only a slight warming of the dipole near the feedpoint can be measured.

The dipole is made of standard semirigid coaxial cable. The center conductor of the feeding line is directly connected to the second arm of the dipole. The antenna is therefore short-circuited for DC-signals.

No excessive force must be applied to the dipole arms, because they might bend or the soldered connections near the feedpoint may be damaged.

**Additional EUT Data**

Manufactured by	SPEAG
Manufactured on	March 09, 2001

**DASY5 Validation Report for Head TSL**

Date/Time: 25.05.2009 09:55:22

Test Laboratory: SPEAG, Zurich, Switzerland

**DUT: Dipole 835 MHz; Type: D835V2; Serial: D835V2 - SN:441**

Communication System: CW-835; Frequency: 835 MHz; Duty Cycle: 1:1

Medium: HSL 900 MHz

Medium parameters used:  $f = 835$  MHz;  $\sigma = 0.89$  mho/m;  $\epsilon_r = 40.7$ ;  $\rho = 1000$  kg/m<sup>3</sup>

Phantom section: Flat Section

Measurement Standard: DASY5 (IEEE/IEC)

## DASY5 Configuration:

- Probe: ES3DV2 - SN3025; ConvF(5.86, 5.86, 5.86); Calibrated: 30.04.2009
- Sensor-Surface: 3mm (Mechanical Surface Detection)
- Electronics: DAE4 Sn601; Calibrated: 07.03.2009
- Phantom: Flat Phantom 4.9L; Type: QD000P49AA; Serial: 1001
- Measurement SW: DASY5, V5.0 Build 120; SEMCAD X Version 13.4 Build 45

**Pin=250mW; dip=15mm/Zoom Scan (7x7x7)/Cube 0;** Measurement grid: dx=5mm, dy=5mm, dz=5mm

Reference Value = 57.1 V/m; Power Drift = 0.0073 dB

Peak SAR (extrapolated) = 3.53 W/kg

**SAR(1 g) = 2.38 mW/g; SAR(10 g) = 1.56 mW/g**

Maximum value of SAR (measured) = 2.77 mW/g

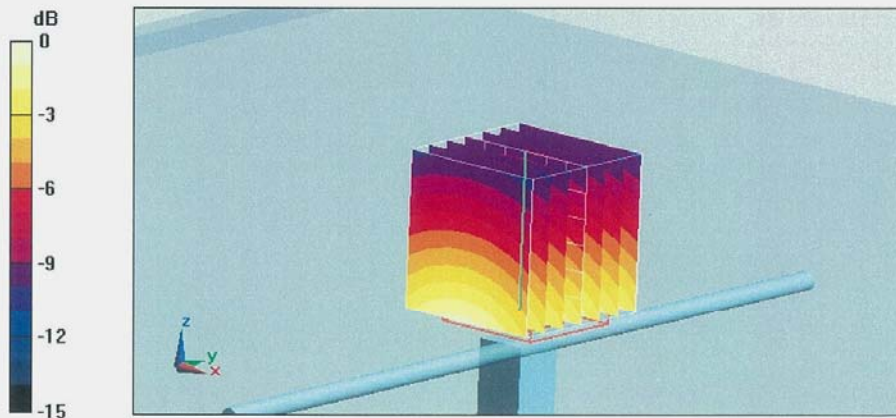

0 dB = 2.77mW/g

**Impedance Measurement Plot for Head TSL**

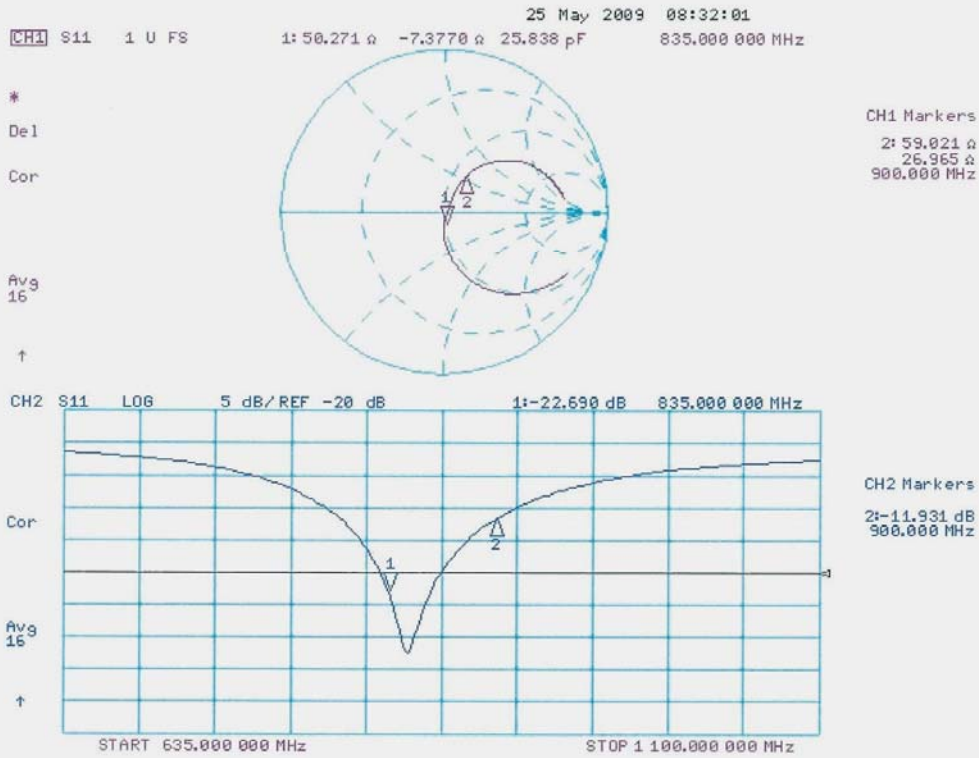

**Calibration Laboratory of  
Schmid & Partner  
Engineering AG**  
Zeughausstrasse 43, 8004 Zurich, Switzerland



**S** Schweizerischer Kalibrierdienst  
**C** Service suisse d'étalonnage  
**S** Servizio svizzero di taratura  
**S** Swiss Calibration Service

Accredited by the Swiss Accreditation Service (SAS)  
The Swiss Accreditation Service is one of the signatories to the EA  
Multilateral Agreement for the recognition of calibration certificates

Accreditation No.: **SCS 108**

Client **H-CT (Dymstec)**

Certificate No: **D1900V2-5d032-Jul08**

**CALIBRATION CERTIFICATE**

Object **D1900V2 - SN: 5d032**

Calibration procedure(s) **QA CAL-05.v7  
Calibration procedure for dipole validation kits**

Calibration date: **July 22, 2008**

Condition of the calibrated item **In Tolerance**

This calibration certificate documents the traceability to national standards, which realize the physical units of measurements (SI).  
The measurements and the uncertainties with confidence probability are given on the following pages and are part of the certificate.

All calibrations have been conducted in the closed laboratory facility; environment temperature (22 ± 3)°C and humidity < 70%.

Calibration Equipment used (M&TE critical for calibration)

Primary Standards	ID #	Cal Date (Calibrated by, Certificate No.)	Scheduled Calibration
Power meter EPM-442A	GB37480704	04-Oct-07 (No. 217-00736)	Oct-08
Power sensor HP 8481A	US37292783	04-Oct-07 (No. 217-00736)	Oct-08
Reference 20 dB Attenuator	SN: 5086 (20g)	01-Jul-08 (No. 217-00864)	Jul-09
Type-N mismatch combination	SN: 5047.2 / 06327	01-Jul-08 (No. 217-00867)	Jul-09
Reference Probe ES3DV2	SN: 3025	28-Apr-08 (No. ES3-3025_Apr08)	Apr-09
DAE4	SN: 601	14-Mar-08 (No. DAE4-601_Mar08)	Mar-09

Secondary Standards	ID #	Check Date (in house)	Scheduled Check
Power sensor HP 8481A	MY41092317	18-Oct-02 (in house check Oct-07)	In house check: Oct-09
RF generator R&S SMT-06	100005	4-Aug-99 (in house check Oct-07)	In house check: Oct-09
Network Analyzer HP 8753E	US37390585 S4206	18-Oct-01 (in house check Oct-07)	In house check: Oct-08

	Name	Function	Signature
Calibrated by:	Jeton Kastrati	Laboratory Technician	
Approved by:	Katja Pokovic	Technical Manager	

Issued: July 22, 2008

This calibration certificate shall not be reproduced except in full without written approval of the laboratory.

**Calibration Laboratory of**  
Schmid & Partner  
Engineering AG  
Zeughausstrasse 43, 8004 Zurich, Switzerland



**S** Schweizerischer Kalibrierdienst  
**C** Service suisse d'étalonnage  
**S** Servizio svizzero di taratura  
**S** Swiss Calibration Service

Accredited by the Swiss Accreditation Service (SAS)  
The Swiss Accreditation Service is one of the signatories to the EA  
Multilateral Agreement for the recognition of calibration certificates

Accreditation No.: **SCS 108**

**Glossary:**

TSL tissue simulating liquid  
ConvF sensitivity in TSL / NORM x,y,z  
N/A not applicable or not measured

**Calibration is Performed According to the Following Standards:**

- a) IEEE Std 1528-2003, "IEEE Recommended Practice for Determining the Peak Spatial-Averaged Specific Absorption Rate (SAR) in the Human Head from Wireless Communications Devices: Measurement Techniques", December 2003
- b) CENELEC EN 50361, "Basic standard for the measurement of Specific Absorption Rate related to human exposure to electromagnetic fields from mobile phones (300 MHz - 3 GHz), July 2001
- c) Federal Communications Commission Office of Engineering & Technology (FCC OET), "Evaluating Compliance with FCC Guidelines for Human Exposure to Radiofrequency Electromagnetic Fields; Additional Information for Evaluating Compliance of Mobile and Portable Devices with FCC Limits for Human Exposure to Radiofrequency Emissions", Supplement C (Edition 01-01) to Bulletin 65

**Additional Documentation:**

- d) DASY4/5 System Handbook

**Methods Applied and Interpretation of Parameters:**

- *Measurement Conditions:* Further details are available from the Validation Report at the end of the certificate. All figures stated in the certificate are valid at the frequency indicated.
- *Antenna Parameters with TSL:* The dipole is mounted with the spacer to position its feed point exactly below the center marking of the flat phantom section, with the arms oriented parallel to the body axis.
- *Feed Point Impedance and Return Loss:* These parameters are measured with the dipole positioned under the liquid filled phantom. The impedance stated is transformed from the measurement at the SMA connector to the feed point. The Return Loss ensures low reflected power. No uncertainty required.
- *Electrical Delay:* One-way delay between the SMA connector and the antenna feed point. No uncertainty required.
- *SAR measured:* SAR measured at the stated antenna input power.
- *SAR normalized:* SAR as measured, normalized to an input power of 1 W at the antenna connector.
- *SAR for nominal TSL parameters:* The measured TSL parameters are used to calculate the nominal SAR result.

**Measurement Conditions**

DASY system configuration, as far as not given on page 1.

<b>DASY Version</b>	DASY4	V4.7
<b>Extrapolation</b>	Advanced Extrapolation	
<b>Phantom</b>	Modular Flat Phantom V5.0	
<b>Distance Dipole Center - TSL</b>	10 mm	with Spacer
<b>Zoom Scan Resolution</b>	dx, dy, dz = 5 mm	
<b>Frequency</b>	1900 MHz $\pm$ 1 MHz	

**Head TSL parameters**

The following parameters and calculations were applied.

	Temperature	Permittivity	Conductivity
<b>Nominal Head TSL parameters</b>	22.0 °C	40.0	1.40 mho/m
<b>Measured Head TSL parameters</b>	(22.0 $\pm$ 0.2) °C	38.8 $\pm$ 6 %	1.47 mho/m $\pm$ 6 %
<b>Head TSL temperature during test</b>	(22.0 $\pm$ 0.2) °C	---	---

**SAR result with Head TSL**

<b>SAR averaged over 1 cm<sup>3</sup> (1 g) of Head TSL</b>	condition	
SAR measured	250 mW input power	9.82 mW / g
SAR normalized	normalized to 1W	39.3 mW / g
SAR for nominal Head TSL parameters <sup>1</sup>	normalized to 1W	<b>37.7 mW / g <math>\pm</math> 17.0 % (k=2)</b>

<b>SAR averaged over 10 cm<sup>3</sup> (10 g) of Head TSL</b>	Condition	
SAR measured	250 mW input power	5.05 mW / g
SAR normalized	normalized to 1W	20.2 mW / g
SAR for nominal Head TSL parameters <sup>1</sup>	normalized to 1W	<b>19.7 mW / g <math>\pm</math> 16.5 % (k=2)</b>

<sup>1</sup> Correction to nominal TSL parameters according to d), chapter "SAR Sensitivities"

**Appendix****Antenna Parameters with Head TSL**

Impedance, transformed to feed point	53.5 $\Omega$ + 4.9 j $\Omega$
Return Loss	- 24.8 dB

**General Antenna Parameters and Design**

Electrical Delay (one direction)	1.185 ns
----------------------------------	----------

After long term use with 100W radiated power, only a slight warming of the dipole near the feedpoint can be measured.

The dipole is made of standard semirigid coaxial cable. The center conductor of the feeding line is directly connected to the second arm of the dipole. The antenna is therefore short-circuited for DC-signals.

No excessive force must be applied to the dipole arms, because they might bend or the soldered connections near the feedpoint may be damaged.

**Additional EUT Data**

Manufactured by	SPEAG
Manufactured on	March 17, 2003

**DASY4 Validation Report for Head TSL**

Date/Time: 22.07.2008 10:06:43

Test Laboratory: SPEAG, Zurich, Switzerland

**DUT: Dipole 1900 MHz; Type: D1900V2; Serial: D1900V2 - SN:5d032**

Communication System: CW; Frequency: 1900 MHz; Duty Cycle: 1:1

Medium: HSL U10 BB;

Medium parameters used:  $f = 1900$  MHz;  $\sigma = 1.47$  mho/m;  $\epsilon_r = 38.8$ ;  $\rho = 1000$  kg/m<sup>3</sup>

Phantom section: Flat Section

Measurement Standard: DASY4 (High Precision Assessment)

**DASY4 Configuration:**

- Probe: ES3DV2 - SN3025; ConvF(4.9, 4.9, 4.9); Calibrated: 28.04.2008
- Sensor-Surface: 3.4mm (Mechanical Surface Detection)
- Electronics: DAE4 Sn601; Calibrated: 14.03.2008
- Phantom: Flat Phantom 5.0 (front); Type: QD000P50AA; ;
- Measurement SW: DASY4, V4.7 Build 71; Postprocessing SW: SEMCAD, V1.8 Build 184

**Pin = 250 mW; dip = 10 mm, scan at 3.4mm/Zoom Scan (dist=3.4mm, probe 0deg)****(7x7x7)/Cube 0:** Measurement grid: dx=5mm, dy=5mm, dz=5mm

Reference Value = 92.2 V/m; Power Drift = 0.010 dB

Peak SAR (extrapolated) = 18.2 W/kg

**SAR(1 g) = 9.82 mW/g; SAR(10 g) = 5.05 mW/g**

Maximum value of SAR (measured) = 11.9 mW/g

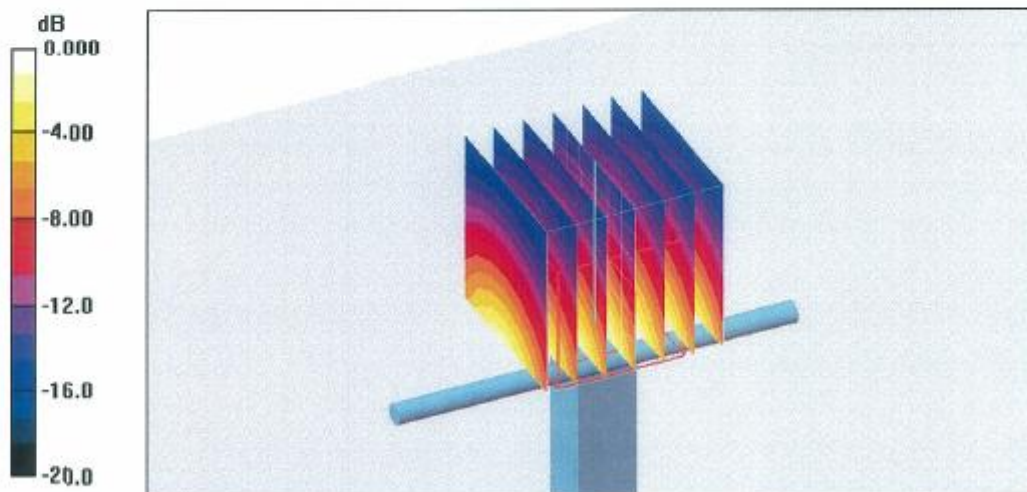

**Impedance Measurement Plot for Head TSL**

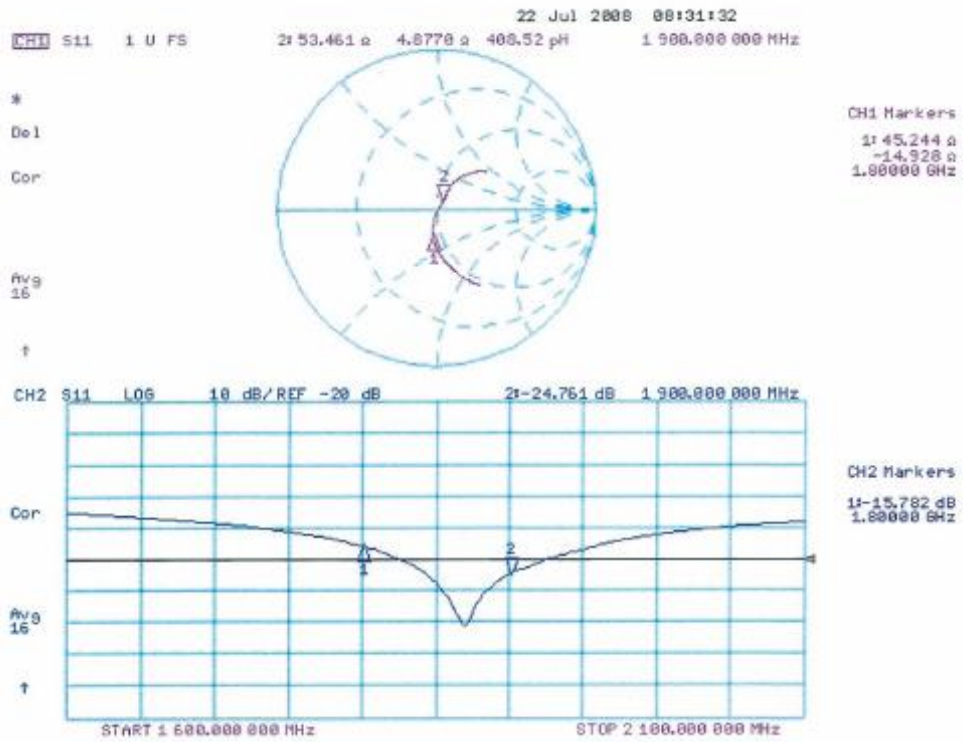

**Calibration Laboratory of  
Schmid & Partner  
Engineering AG**  
Zeughausstrasse 43, 8004 Zurich, Switzerland



**S** Schweizerischer Kalibrierdienst  
**S** Service suisse d'étalonnage  
**S** Servizio svizzero di taratura  
**S** Swiss Calibration Service

Accredited by the Swiss Accreditation Service (SAS)  
The Swiss Accreditation Service is one of the signatories to the EA  
Multilateral Agreement for the recognition of calibration certificates

Accreditation No.: **SCS 108**

Client **H-CT (Dymstec)**

Certificate No: **D2450V2-743\_Aug08**

**CALIBRATION CERTIFICATE**

Object **D2450V2 - SN: 743**

Calibration procedure(s) **QA CAL-05.v7  
Calibration procedure for dipole validation kits**

Calibration date: **August 27, 2008**

Condition of the calibrated item **In Tolerance**

This calibration certificate documents the traceability to national standards, which realize the physical units of measurements (SI).  
The measurements and the uncertainties with confidence probability are given on the following pages and are part of the certificate.

All calibrations have been conducted in the closed laboratory facility: environment temperature (22 ± 3)°C and humidity < 70%.

Calibration Equipment used (M&TE critical for calibration)

Primary Standards	ID #	Cal Date (Certificate No.)	Scheduled Calibration
Power meter EPM-442A	GB37480704	04-Oct-07 (No. 217-00736)	Oct-08
Power sensor HP 8481A	US37292783	04-Oct-07 (No. 217-00736)	Oct-08
Reference 20 dB Attenuator	SN: S5086 (20g)	01-Jul-08 (No. 217-00864)	Jul-09
Type-N mismatch combination	SN: 5047.2 / 06327	01-Jul-08 (No. 217-00867)	Jul-09
Reference Probe ES3DV2	SN: 3025	28-Apr-08 (No. ES3-3025_Apr08)	Apr-09
DAE4	SN: 601	14-Mar-08 (No. DAE4-601_Mar08)	Mar-09
Secondary Standards	ID #	Check Date (in house)	Scheduled Check
Power sensor HP 8481A	MY41092317	18-Oct-02 (in house check Oct-07)	In house check: Oct-09
RF generator R&S SMT-06	100005	4-Aug-99 (in house check Oct-07)	In house check: Oct-09
Network Analyzer HP 8753E	US37390585 S4206	18-Oct-01 (in house check Oct-07)	In house check: Oct-08

	Name	Function	Signature
Calibrated by:	Jeton Kastrati	Laboratory Technician	
Approved by:	Katja Pokovic	Technical Manager	

Issued: August 27, 2008

This calibration certificate shall not be reproduced except in full without written approval of the laboratory.

**Calibration Laboratory of  
Schmid & Partner  
Engineering AG**  
Zeughausstrasse 43, 8004 Zurich, Switzerland



**S** Schweizerischer Kalibrierdienst  
**C** Service suisse d'étalonnage  
**S** Servizio svizzero di taratura  
**S** Swiss Calibration Service

Accredited by the Swiss Accreditation Service (SAS)  
The Swiss Accreditation Service is one of the signatories to the EA  
Multilateral Agreement for the recognition of calibration certificates

Accreditation No.: **SCS 108**

**Glossary:**

TSL	tissue simulating liquid
ConvF	sensitivity in TSL / NORM x,y,z
N/A	not applicable or not measured

**Calibration is Performed According to the Following Standards:**

- IEEE Std 1528-2003, "IEEE Recommended Practice for Determining the Peak Spatial-Averaged Specific Absorption Rate (SAR) in the Human Head from Wireless Communications Devices: Measurement Techniques", December 2003
- IEC 62209-1, "Procedure to measure the Specific Absorption Rate (SAR) for hand-held devices used in close proximity to the ear (frequency range of 300 MHz to 3 GHz)", February 2005
- Federal Communications Commission Office of Engineering & Technology (FCC OET), "Evaluating Compliance with FCC Guidelines for Human Exposure to Radiofrequency Electromagnetic Fields; Additional Information for Evaluating Compliance of Mobile and Portable Devices with FCC Limits for Human Exposure to Radiofrequency Emissions", Supplement C (Edition 01-01) to Bulletin 65

**Additional Documentation:**

- DASY4/5 System Handbook

**Methods Applied and Interpretation of Parameters:**

- Measurement Conditions:** Further details are available from the Validation Report at the end of the certificate. All figures stated in the certificate are valid at the frequency indicated.
- Antenna Parameters with TSL:** The dipole is mounted with the spacer to position its feed point exactly below the center marking of the flat phantom section, with the arms oriented parallel to the body axis.
- Feed Point Impedance and Return Loss:** These parameters are measured with the dipole positioned under the liquid filled phantom. The impedance stated is transformed from the measurement at the SMA connector to the feed point. The Return Loss ensures low reflected power. No uncertainty required.
- Electrical Delay:** One-way delay between the SMA connector and the antenna feed point. No uncertainty required.
- SAR measured:** SAR measured at the stated antenna input power.
- SAR normalized:** SAR as measured, normalized to an input power of 1 W at the antenna connector.
- SAR for nominal TSL parameters:** The measured TSL parameters are used to calculate the nominal SAR result.

**Measurement Conditions**

DASY system configuration, as far as not given on page 1.

<b>DASY Version</b>	DASY5	V5.0
<b>Extrapolation</b>	Advanced Extrapolation	
<b>Phantom</b>	Modular Flat Phantom V5.0	
<b>Distance Dipole Center - TSL</b>	10 mm	with Spacer
<b>Zoom Scan Resolution</b>	dx, dy, dz = 5 mm	
<b>Frequency</b>	2450 MHz $\pm$ 1 MHz	

**Head TSL parameters**

The following parameters and calculations were applied.

	Temperature	Permittivity	Conductivity
<b>Nominal Head TSL parameters</b>	22.0 °C	39.2	1.80 mho/m
<b>Measured Head TSL parameters</b>	(22.0 $\pm$ 0.2) °C	38.1 $\pm$ 6 %	1.80 mho/m $\pm$ 6 %
<b>Head TSL temperature during test</b>	(22.0 $\pm$ 0.2) °C	----	----

**SAR result with Head TSL**

<b>SAR averaged over 1 cm<sup>3</sup> (1 g) of Head TSL</b>	Condition	
SAR measured	250 mW input power	13.3 mW / g
SAR normalized	normalized to 1W	53.2 mW / g
SAR for nominal Head TSL parameters <sup>1</sup>	normalized to 1W	<b>52.4 mW /g <math>\pm</math> 17.0 % (k=2)</b>

<b>SAR averaged over 10 cm<sup>3</sup> (10 g) of Head TSL</b>	condition	
SAR measured	250 mW input power	6.17 mW / g
SAR normalized	normalized to 1W	24.7 mW / g
SAR for nominal Head TSL parameters <sup>1</sup>	normalized to 1W	<b>24.4 mW /g <math>\pm</math> 16.5 % (k=2)</b>

<sup>1</sup> Correction to nominal TSL parameters according to d), chapter "SAR Sensitivities"

**Appendix****Antenna Parameters with Head TSL**

Impedance, transformed to feed point	53.8 $\Omega$ + 3.8 j $\Omega$
Return Loss	- 25.8 dB

**General Antenna Parameters and Design**

Electrical Delay (one direction)	1.162 ns
----------------------------------	----------

After long term use with 100W radiated power, only a slight warming of the dipole near the feedpoint can be measured.

The dipole is made of standard semirigid coaxial cable. The center conductor of the feeding line is directly connected to the second arm of the dipole. The antenna is therefore short-circuited for DC-signals.

No excessive force must be applied to the dipole arms, because they might bend or the soldered connections near the feedpoint may be damaged.

**Additional EUT Data**

Manufactured by	SPEAG
Manufactured on	December 01, 2003

**DASY5 Validation Report for Head TSL**

Date/Time: 27.08.2008 11:29:32

Test Laboratory: SPEAG, Zurich, Switzerland

**DUT: Dipole 2450 MHz; Type: D2450V2; Serial: D2450V2 - SN743**

Communication System: CW; Frequency: 2450 MHz; Duty Cycle: 1:1

Medium: HSL U10 BB

Medium parameters used:  $f = 2450$  MHz;  $\sigma = 1.8$  mho/m;  $\epsilon_r = 38.1$ ;  $\rho = 1000$  kg/m<sup>3</sup>

Phantom section: Flat Section

Measurement Standard: DASY5 (IEEE/IEC)

**DASY5 Configuration:**

- Probe: ES3DV2 - SN3025; ConvF(4.4, 4.4, 4.4); Calibrated: 28.04.2008
- Sensor-Surface: 3.4mm (Mechanical Surface Detection)
- Electronics: DAE4 Sn601; Calibrated: 14.03.2008
- Phantom: Flat Phantom 5.0 (front); Type: QD000P50AA; Serial: 1001
- Measurement SW: DASY5, V5.0 Build 119; SEMCAD X Version 13.2 Build 87

**Pin = 250 mW; d = 10 mm/Zoom Scan (7x7x7)/Cube 0:** Measurement grid: dx=5mm, dy=5mm, dz=5mm

Reference Value = 96.6 V/m; Power Drift = 0.054 dB

Peak SAR (extrapolated) = 28.2 W/kg

**SAR(1 g) = 13.3 mW/g; SAR(10 g) = 6.17 mW/g**

Maximum value of SAR (measured) = 16 mW/g

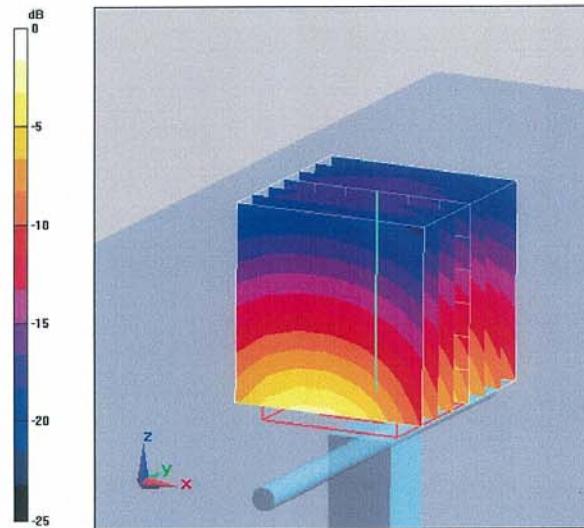

0 dB = 16mW/g

Impedance Measurement Plot for Head TSL

