



PCTEST ENGINEERING LABORATORY, INC.

6660-B Dobbin Road, Columbia, MD 21045 USA
Tel. 410.290.6652 / Fax 410.290.6554
<http://www.pctestlab.com>



CERTIFICATE OF COMPLIANCE FCC Part 24 & 22 Class II Permissive Change

Applicant Name:
LG Electronics USA
1000 Sylvan Avenue
Englewood Cliffs, NJ 07632
United States

Date of Testing:
May 8 - 9, 2006
Test Site/Location:
PCTEST Lab, Columbia, MD, USA
Test Report Serial No.:
0604200307

FCC ID: BEJAX490

APPLICANT: LG ELECTRONICS USA

Application Type: Class II Permissive Change
FCC Classification: PCS Licensed Transmitter Held to Ear (PCE)
FCC Rule Part(s): §24(E), §22(H); §2
EUT Type: Tri-Mode Dual-Band Analog/ PCS Phone (AMPS/ CDMA) with Bluetooth
Model(s): AX490
Tx Frequency Range: 824.04 - 848.97 MHz (AMPS) / 824.70 - 848.31 MHz (Cellular CDMA) / 1851.25 - 1908.75 MHz (PCS CDMA)
Rx Frequency Range: 869.04 - 893.97MHz (AMPS) / 869.70 - 893.31 MHz (Cellular CDMA) / 1931.25 - 1988.75 MHz (PCS CDMA)
Max. RF Output Power: 0.439 W ERP AMPS (26.425 dBm) / 0.284 W ERP Cellular CDMA (24.533 dBm) / 0.275 W EIRP PCS CDMA (24.393 dBm)
Max. SAR Measurement: 0.474 W/kg AMPS Head SAR; 0.686 W/kg AMPS Body SAR
0.254 W/kg CDMA Head SAR; 0.596 W/kg CDMA Body SAR
0.784 W/kg PCS CDMA Head SAR; 0.190 W/kg PCS CDMA Body SAR
Emission Designator(s): 40K0F8W/ 40K0F1D/1M25F9W
Test Device Serial No.: *identical prototype* [S/N: 19D52B18]
Class II Permissive Change: See Change Document
Original Grant Date: 04/07/2006

This equipment has been shown to be capable of compliance with the applicable technical standards as indicated in the measurement report and was tested in accordance with the measurement procedures specified in §2.947.



I attest to the accuracy of data. All measurements reported herein were performed by me or were made under my supervision and are correct to the best of my knowledge and belief. I assume full responsibility for the completeness of these measurements and vouch for the qualifications of all persons taking them.

Grant Conditions: Power output listed is ERP for Part 22 and EIRP for Part 24. SAR compliance for body-worn operating configuration is based on a separation distance of 1.5 cm between the back of the unit and the body of the user. End-users must be informed of the body-worn operating requirements for satisfying RF exposure compliance. Belt clips or holsters may not contain metallic components.

PCTEST certifies that no party to this application has been denied the FCC benefits pursuant to Section 5301 of the Anti-Drug Abuse Act of 1988, 21 U.S.C. 862.



Randy Ortanez
President



PCTEST™ PT. 22/24 TEST REPORT		FCC MEASUREMENT REPORT		Reviewed by: Quality Manager
Test Report S/N: 0604200307	Test Dates: May 8 - 9, 2006	EUT Type: Tri-Mode Dual-Band Analog/ PCS Phone (AMPS/ CDMA) with Bluetooth	FCC ID: BEJAX490	Page 1 of 34



T A B L E O F C O N T E N T S

1.0	SCOPE	4
2.0	INTRODUCTION	5
	2.1 TESTING FACILITY	5
	2.2 MEASUREMENT PROCEDURE	5
3.0	INSERTS	6
4.0	DESCRIPTION OF TESTS	7
	4.1 TRANSMITTER AUDIO FREQUENCY RESPONSE	7
	4.2 AUDIO LOW PASS FILTER FREQUENCY RESPONSE	7
	4.3 MODULATION LIMITING	7
	4.4 OCCUPIED BANDWIDTH EMISSION LIMITS	8
	4.5 CELLULAR - BASE FREQUENCY BLOCKS	8
	4.6 CELLULAR - MOBILE FREQUENCY BLOCKS	8
	4.7 PCS - BASE FREQUENCY BLOCKS	9
	4.8 PCS - MOBILE FREQUENCY BLOCKS	9
	4.9 OCCUPIED BANDWIDTH	10
	4.10 SPURIOUS AND HARMONIC EMISSIONS AT ANTENNA TERMINAL	10
	4.11 FREQUENCIES	10
	4.12 RADIATED SPURIOUS AND HARMONIC EMISSIONS	10
	4.13 FREQUENCY STABILITY / TEMPERATURE VARIATION	11
5.0	CONDUCTED OUTPUT POWER	12
	5.1 SAR MEASUREMENT CONDITIONS FOR CDMA2000	12
	5.2 OUTPUT POWER VERIFICATION	12
6.0	EFFECTIVE RADIATED POWER	13
	6.1 EFFECTIVE RADIATED POWER OUTPUT DATA	13
7.0	EQUIVALENT ISOTROPIC RADIATED POWER	15
	7.1 EQUIVALENT ISOTROPIC RADIATED POWER OUTPUT DATA	15
8.0	RADIATED MEASUREMENTS	16
	8.1 AMPS RADIATED MEASUREMENTS	16
	8.2 CELLULAR CDMA RADIATED MEASUREMENTS	19
	8.3 PCS CDMA RADIATED MEASUREMENTS	22
9.0	FREQUENCY STABILITY	25
	9.1 FREQUENCY STABILITY (AMPS)	25
	9.2 FREQUENCY STABILITY (CELLULAR CDMA)	27
	9.3 FREQUENCY STABILITY (PCS CDMA)	29
10.0	PLOT(S) OF EMISSIONS	31
11.0	TEST EQUIPMENT	32
12.0	SAMPLE CALCULATIONS	33

PCTEST™ PT. 22/24 TEST REPORT		FCC MEASUREMENT REPORT		Reviewed by: Quality Manager
Test Report S/N: 0604200307	Test Dates: May 8 - 9, 2006	EUT Type: Tri-Mode Dual-Band Analog/ PCS Phone (AMPS/ CDMA) with Bluetooth	FCC ID: BEJAX490	Page 2 of 34



12.1	EMISSION DESIGNATOR	33
12.2	SPURIOUS RADIATED EMISSION - PCS BAND	33
13.0	CONCLUSION.....	34
ATTACHMENT A:	TEST PLOTS	
ATTACHMENT B:	TEST SETUP PHOTOGRAPHS	
ATTACHMENT C:	EXTERNAL PHOTOGRAPHS	
ATTACHMENT D:	INTERNAL PHOTOGRAPHS	

PCTEST™ PT. 22/24 TEST REPORT		FCC MEASUREMENT REPORT		Reviewed by: Quality Manager
Test Report S/N: 0604200307	Test Dates: May 8 - 9, 2006	EUT Type: Tri-Mode Dual-Band Analog/ PCS Phone (AMPS/ CDMA) with Bluetooth	FCC ID: BEJAX490	Page 3 of 34

1.0 SCOPE

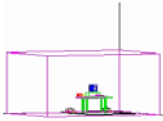

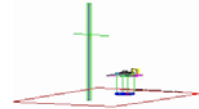

Measurement and determination of electromagnetic emissions (EME) of radio frequency devices including intentional and/or unintentional radiators for compliance with the technical rules and regulations of the Federal Communications Commission.



§2.1033 General Information

Applicant Name: LG Electronics USA
 Address: 1000 Sylvan Avenue
 Englewood Cliffs, NJ 07632
 United States

- FCC ID: BEJAX490
- Quantity: Quantity production is planned
- Emission Designators: 40K0F8W / 40K0F1D (AMPS), 1M25F9W (CDMA)
- Tx Freq. Range: 824.04 - 848.97 MHz (AMPS)
 824.70 - 848.31 MHz (Cellular CDMA)
 1851.25 - 1908.75 MHz (PCS CDMA)
- Rx Freq. Range: 869.04 - 893.97MHz (AMPS)
 869.70 - 893.31 MHz (Cellular CDMA)
 1931.25 – 1988.75 MHz (PCS CDMA)
- Max. Power Rating: 0.439 W ERP AMPS (26.425 dBm) /
 0.284 W ERP Cellular CDMA (24.533 dBm) /
 0.275 W EIRP PCS CDMA (24.393 dBm)
- FCC Classification(s): Licensed Portable Tx Held to Ear (PCE)
- Equipment (EUT) Type: Tri-Mode Dual-Band Analog/ PCS Phone (AMPS/ CDMA) with Bluetooth
- Modulation(s): AMPS / CDMA
- Frequency Tolerance: ±0.00025 % (2.5 ppm)
- FCC Rule Part(s): § 24(E), §22(H)
- Dates of Tests: May 8 - 9, 2006
- Place of Tests: PCTEST Lab, Columbia, MD U.S.A.
- Test Report S/N: 0604200307
- *Deviation from measurement procedure - None*

PCTEST™ PT. 22/24 TEST REPORT		FCC MEASUREMENT REPORT		Reviewed by: Quality Manager
Test Report S/N: 0604200307	Test Dates: May 8 - 9, 2006	EUT Type: Tri-Mode Dual-Band Analog/ PCS Phone (AMPS/ CDMA) with Bluetooth	FCC ID: BEJAX490	Page 4 of 34

2.0 INTRODUCTION

2.1 Testing Facility

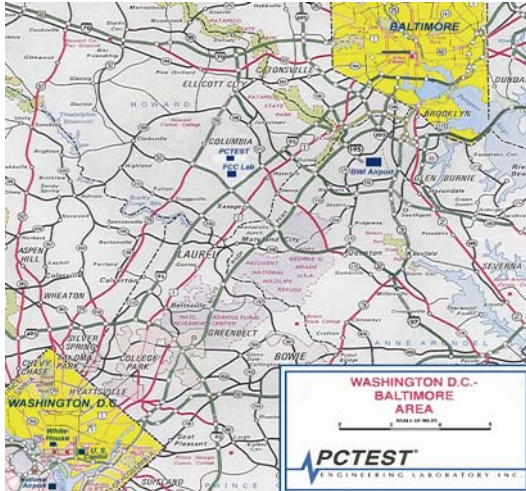

Figure 1. Map of the Greater Baltimore and Metropolitan Washington, D.C. area.

These measurement tests were conducted at the PCTEST Engineering Laboratory, Inc. facility in New Concept Business Park, Guilford Industrial Park, Columbia, Maryland. The site address is 6660-B Dobbin Road, Columbia, MD 21045. The test site is one of the highest points in the Columbia area with an elevation of 390 feet above mean sea level. The site coordinates are 39° 11'15" N latitude and 76° 49'38" W longitude. The facility is 1.5 miles North of the FCC laboratory, and the ambient signal and ambient signal strength are approximately equal to those of the FCC laboratory. There are no FM or TV transmitters within 15 miles of the site. The detailed description of the measurement facility was found to be in compliance with the requirements of § 2.948 according to ANSI C63.4 on October 19, 1992.

2.2 Measurement Procedure

The radiated spurious measurements were made outdoors at a 3-meter test range (see Figure 2). The equipment under test is placed on a wooden turntable 3-meters from the receive antenna. The receive antenna height and turntable rotations were adjusted for the highest reading on the receive spectrum analyzer. A half-wave dipole was substituted in place of the EUT. This dipole antenna was driven by a signal generator and the level of the signal generator was adjusted to obtain the same receive spectrum analyzer reading. This level is recorded. For readings above 1GHz, the above procedure is repeated using horn antennas and the difference between the gain of the horn and an isotropic antenna are taken into consideration.

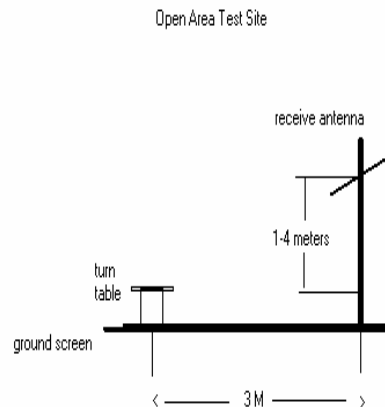



Figure 2. Diagram of 3-meter outdoor test range

PCTEST™ PT. 22/24 TEST REPORT		FCC MEASUREMENT REPORT		Reviewed by: Quality Manager
Test Report S/N: 0604200307	Test Dates: May 8 - 9, 2006	EUT Type: Tri-Mode Dual-Band Analog/ PCS Phone (AMPS/ CDMA) with Bluetooth	FCC ID: BEJAX490	Page 5 of 34

3.0 INSERTS

Function of Active Devices (Confidential)

Block & Schematic Diagrams (Confidential)



Operating Instructions

Parts List & Tune-Up Procedure (Confidential)

Description of Freq. Stabilization Circuit (Confidential)

Description for Suppression of Spurious Radiation, for Limiting Modulation, and Harmonic Suppression Circuits (Confidential)

* These Exhibits are not included.

PCTEST™ PT. 22/24 TEST REPORT		FCC MEASUREMENT REPORT		Reviewed by: Quality Manager
Test Report S/N: 0604200307	Test Dates: May 8 - 9, 2006	EUT Type: Tri-Mode Dual-Band Analog/ PCS Phone (AMPS/ CDMA) with Bluetooth	FCC ID: BEJAX490	Page 6 of 34

4.0 DESCRIPTION OF TESTS

4.1 Transmitter Audio Frequency Response

The frequency response of the audio modulating circuit over the frequency range 100 – 5000 Hz is measured. The audio signal generator is connected to the audio input circuit/microphone of the EUT. The audio signal input is adjusted to obtain 50% modulation at 1kHz and this point is taken as the 0dB reference. With the input held constant and below the limit at all frequencies, the audio signal generator is varied from 100 to 50 kHz.

4.2 Audio Low Pass Filter Frequency Response

The response in dB relative to 1kHz is measured using the HP8901 a Modulation Analyzer. For the frequency response of the audio low-pass filter, the audio input is connected at the input to the modulation limiter and the modulated stage. The audio output is connected at the output of the modulated stage. The corresponding plots are shown herein.

4.3 Modulation Limiting

The audio signal generator is connected to the audio input circuit/microphone of the EUT. The modulation response is measured for each of the three modulating frequencies (300Hz, 1000Hz, and 3000Hz), and the input voltage is varied from 30% modulation (± 3.6 kHz deviation) to at least 20dB higher than the saturation point. Measurements of modulation and the plots are attached herein. Measurements were performed for ST, SAT, and wide-band data modulations. The corresponding results are shown herein.

Note: ST, SAT, & Wide-Band data were internally generated by the EUT.

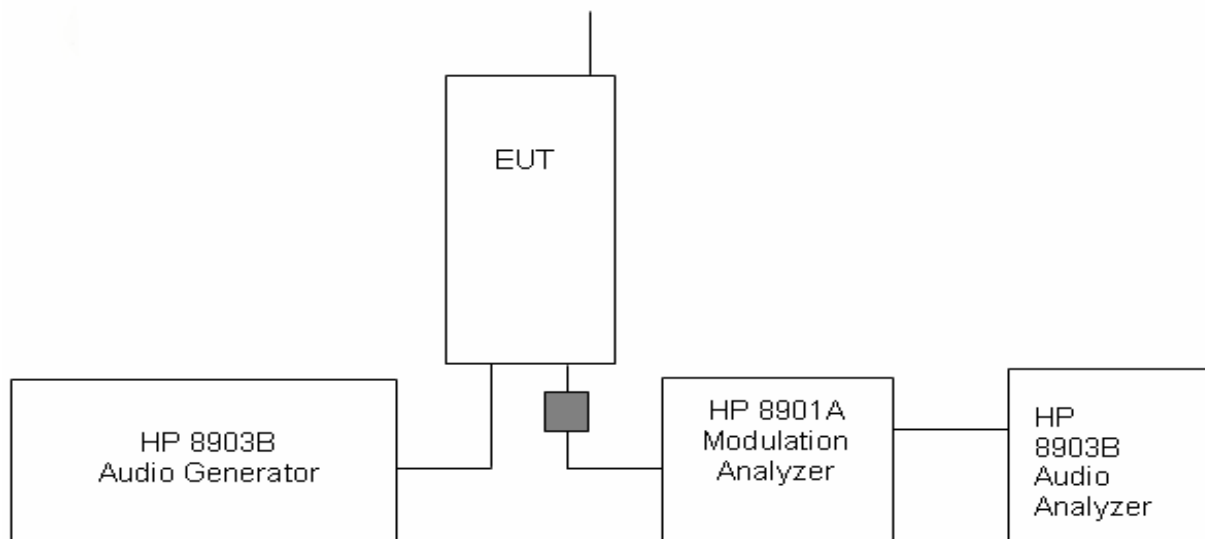



Figure 3. Transmitter Audio Frequency & Tone Modulation Test Setup

PCTEST™ PT. 22/24 TEST REPORT		FCC MEASUREMENT REPORT		Reviewed by: Quality Manager
Test Report S/N: 0604200307	Test Dates: May 8 - 9, 2006	EUT Type: Tri-Mode Dual-Band Analog/ PCS Phone (AMPS/ CDMA) with Bluetooth	FCC ID: BEJAX490	Page 7 of 34

4.4 Occupied Bandwidth Emission Limits

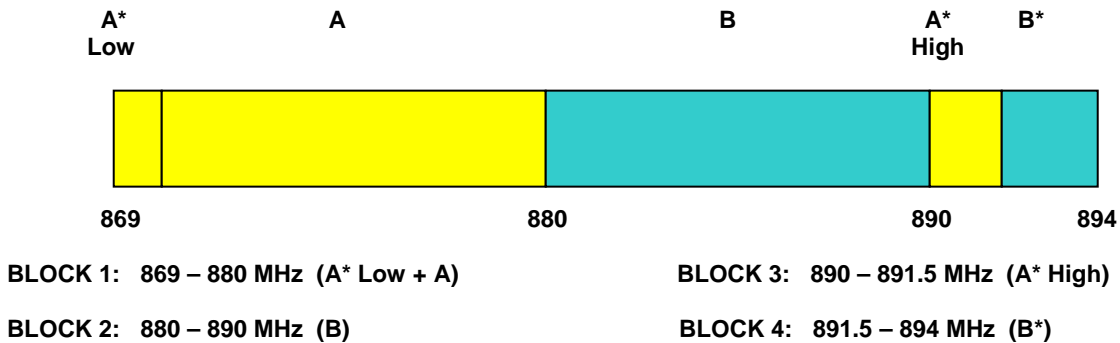

- a. On any frequency outside a licensee's frequency block, the power of any emission shall be attenuated below the transmitter power (P) by at least $43 + 10 \log(P)$ dB.
- b. Compliance with these provisions is based on the use of measurement instrumentation employing a resolution bandwidth of 1 MHz or greater. However, in the 1 MHz bands immediately outside and adjacent to the frequency block a resolution bandwidth of at least one percent of the emission bandwidth of the fundamental emission of the transmitter may be employed. The emission bandwidth is defined as the width of the signal between two points, one below the carrier center frequency and one above the carrier center frequency, outside of which all emission are attenuated at least 26 dB below the transmitter power.
- c. When measuring the emission limits, the nominal carrier frequency shall be adjusted as close to the licensee's frequency block edges, both upper and lower, as the design permits.
- d. The measurement of emission power can be expressed in peak or average values, provided they are expressed in the same parameters as the transmitter power.

4.5 Cellular - Base Frequency Blocks

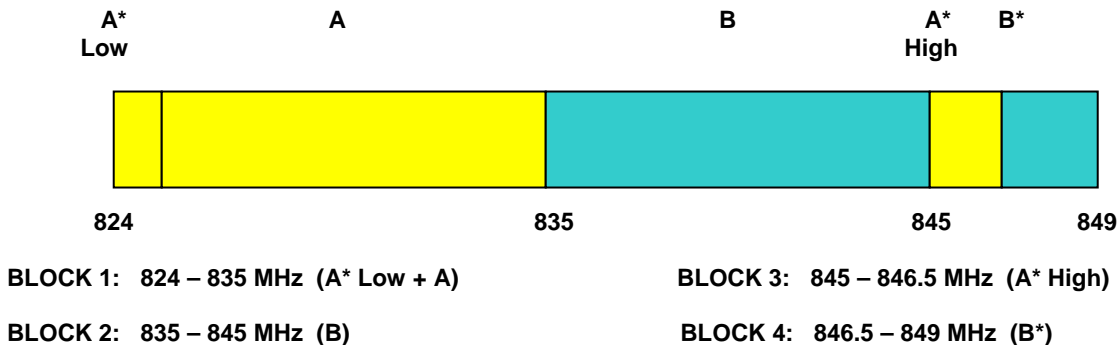

4.6 Cellular - Mobile Frequency Blocks



PCTEST™ PT. 22/24 TEST REPORT		FCC MEASUREMENT REPORT		Reviewed by: Quality Manager
Test Report S/N: 0604200307	Test Dates: May 8 - 9, 2006	EUT Type: Tri-Mode Dual-Band Analog/ PCS Phone (AMPS/ CDMA) with Bluetooth	FCC ID: BEJAX490	Page 8 of 34

4.7 PCS - Base Frequency Blocks

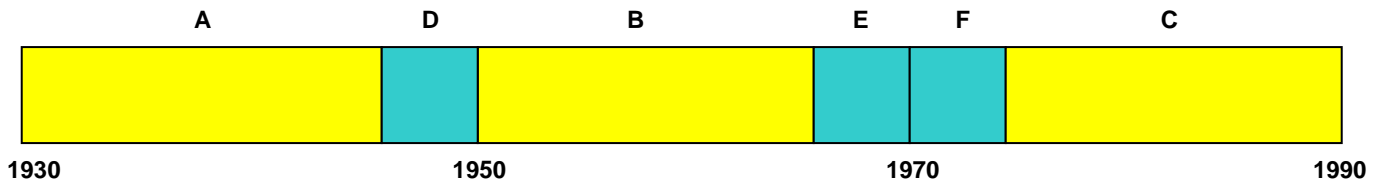

BLOCK 1: 1930 – 1945 MHz (A)

BLOCK 4: 1965 – 1970 MHz (E)

BLOCK 2: 1945 – 1950 MHz (D)

BLOCK 5: 1970 – 1975 MHz (F)

BLOCK 3: 1950 – 1965 MHz (B)

BLOCK 6: 1975 – 1990 MHz (C)

4.8 PCS - Mobile Frequency Blocks

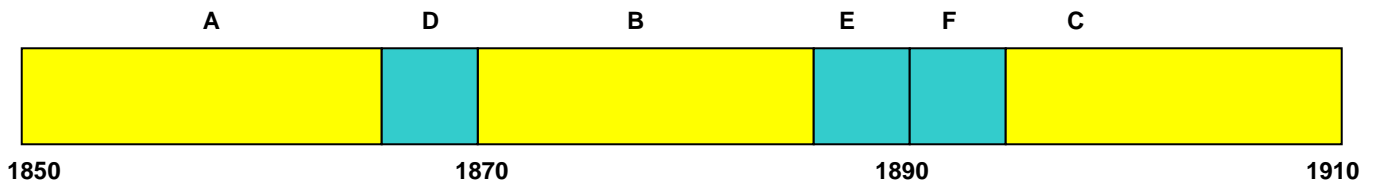

BLOCK 1: 1850 – 1865 MHz (A)



BLOCK 4: 1885 – 1890 MHz (E)

BLOCK 2: 1865 – 1870 MHz (D)

BLOCK 5: 1890 – 1895 MHz (F)

BLOCK 3: 1870 – 1885 MHz (B)

BLOCK 6: 1895 – 1910 MHz (C)

PCTEST™ PT. 22/24 TEST REPORT		FCC MEASUREMENT REPORT		Reviewed by: Quality Manager
Test Report S/N: 0604200307	Test Dates: May 8 - 9, 2006	EUT Type: Tri-Mode Dual-Band Analog/ PCS Phone (AMPS/ CDMA) with Bluetooth	FCC ID: BEJAX490	Page 9 of 34

4.9 Occupied Bandwidth

The audio signal generator is adjusted to 1 kHz. The output level is set to ± 6 kHz deviation. With the level constant, the frequency is set to 2500 Hz. Then the audio signal level is increased by 16 dB. The occupied bandwidth data is obtained for the SAT (Supervisory Audio Tone), ST (Signaling Tone), WBD (Wideband data), and DTMF (Dual Tone Multi Frequencies). The results are shown on the attached graphs.

Specified Limits:

- a. On any frequency removed from the assigned carrier frequency by more than 20 kHz, up to and including 45 kHz, the sideband is at least 26 dB below the carrier.
- b. On any frequency removed from the assigned carrier frequency by more than the 45 kHz, up to and including 90 kHz, the sideband is at least 45 dB below the carrier.
- c. On any frequency removed from the assigned carrier frequency by more than 90 kHz, up to the first multiple of the carrier frequency, the sideband is at least 60dB below the carrier or $40 + \log_{10}(\text{mean power output in Watts})$ dB, whichever is the smaller attenuation.

4.10 Spurious and Harmonic Emissions at Antenna Terminal

The level of the carrier and the various conducted spurious and harmonic frequencies is measured by means of a calibrated spectrum analyzer. The spectrum is scanned from the lowest frequency generated in the equipment up to 10 GHz. The transmitter is modulated with a 2500 Hz tone at a level of 16 dB greater than that required to provide 50% modulation.



At the input terminals of the spectrum analyzer, an isolator (RF circulator with one port terminated in 50Ω) and an 870 MHz to 890 MHz band-pass filter is connected between the test transceiver (for conducted tests) or the receive antenna (for radiated tests) and the analyzer. The rejection of the band-pass filter to signals in the 825 – 845 MHz range is adequate to limit the transmit energy from the test transceiver which appears to a level which will allow the analyzer to measure signals less than -90 dBm. Calibration of the test receiver is performed in the 870 – 890 MHz range to insure accuracy to allow variation in the band-pass filter insertion loss to be calibrated.

4.11 Frequencies

At the input terminals of the spectrum analyzer, an isolator (RF pad) and a high-pass filter are connected between the test transceiver (for conducted tests) or the receive antenna (for radiated tests) and the analyzer. The high-pass filter (signals below 1.6 GHz) is to limit the fundamental frequency from interfering with the measurement of low-level spurious and harmonic emissions and to ensure that the preamplifier is not saturated.

4.12 Radiated Spurious and Harmonic Emissions

Radiation and harmonic emissions are measured outdoors at our 3-meter test range. The equipment under test is placed on a wooden turntable 3-meters from the receive antenna. The receive antenna height and turntable rotations were adjusted for the highest reading on the receive spectrum analyzer. A half-wave dipole was substituted in place of the EUT. This dipole antenna was driven by a signal generator with the level of the signal generator being adjusted to obtain the same receive spectrum analyzer reading. This

PCTEST™ PT. 22/24 TEST REPORT		FCC MEASUREMENT REPORT		Reviewed by: Quality Manager
Test Report S/N: 0604200307	Test Dates: May 8 - 9, 2006	EUT Type: Tri-Mode Dual-Band Analog/ PCS Phone (AMPS/ CDMA) with Bluetooth	FCC ID: BEJAX490	Page 10 of 34



level is recorded. For readings above 1 GHz, the above procedure is repeated using horn antennas and the difference between the gain of the horn and an isotropic or dipole antenna are taken into consideration. This device was tested under all R.C.s and S.O.s and the worst case is reported with RC3/SO55, with "All Up" power control bits.

4.13 Frequency Stability / Temperature Variation

The frequency stability of the transmitter is measured by:

- a.) **Temperature:** The temperature is varied from -30°C to +60°C using an environmental chamber.
- b.) **Primary Supply Voltage:** The primary supply voltage is varied from 85% to 115% of the voltage normally at the input to the device or at the power supply terminals if cables are not normally supplied.

Specification – The frequency stability shall be sufficient to ensure that the fundamental emission stays within the authorized frequency block. The frequency stability of the transmitter shall be maintained within ±0.00025 (±2.5 ppm) of the center frequency.

Time Period and Procedure:

1. The carrier frequency of the transmitter and the individual oscillators is measured at room temperature (22°C to 25°C to provide a reference).
2. The equipment is subjected to an overnight “soak” at -30°C without any power applied.
3. After the overnight “soak” at -30°C (usually 14-16 hours), the equipment is turned on in a “standby” condition for one minute before applying power to the transmitter. Measurement of the carrier frequency of the transmitter and the individual oscillators is made within a three minute interval after applying power to the transmitter.
4. Frequency measurements are made at 10°C interval up to room temperature. At least a period of one and one half-hour is provided to allow stabilization of the equipment at each temperature level.
5. Again the transmitter carrier frequency and the individual oscillators is measured at room temperature to begin measurement of the upper temperature levels.
6. Frequency measurements are at 10 intervals starting at -30°C up to +50°C allowing at least two hours at each temperature for stabilization. In all measurements the frequency is measured within three minutes after re-applying power to the transmitter.
7. The artificial load is mounted external to the temperature chamber.

NOTE: The EUT is tested down to the battery endpoint.

PCTEST™ PT. 22/24 TEST REPORT		FCC MEASUREMENT REPORT		Reviewed by: Quality Manager
Test Report S/N: 0604200307	Test Dates: May 8 - 9, 2006	EUT Type: Tri-Mode Dual-Band Analog/ PCS Phone (AMPS/ CDMA) with Bluetooth	FCC ID: BEJAX490	Page 11 of 34

5.0 CONDUCTED OUTPUT POWER

This device was tested under all R.C.s and S.O.s and the worst case is reported with RC3/SO55, with "All Up" power control bits.

5.1 SAR Measurement Conditions for CDMA2000

The following procedures were followed according to FCC "SAR Measurement Procedures for 3G Devices", May 2006.

5.2 Output Power Verification

See 3GPP2 C.S0011/TIA-98-E as recommended by "SAR Measurement Procedures for 3G Devices", May 2006.

1. If the mobile station (MS) supports Reverse TCH RC 1 and Forward TCH RC 1, set up a call using Fundamental Channel Test Mode 1 (RC=1/1) with 9600 bps data rate only.
2. Under RC1, C.S0011 Table 4.4.5.2-1, Table 5-1 parameters were applied.
3. If the MS supports the RC 3 Reverse FCH, RC3 Reverse SCH0 and demodulation of RC 3,4, or 5, set up a call using Supplemental Channel Test Mode 3 (RC 3/3) with 9600 bps Fundamental Channel and 9600 bps SCH0 data rate.
4. Under RC3, C.S0011 Table 4.4.5.2-2, Table 5-2 was applied.
5. FCHs were configured at full rate for maximum SAR with "All Up" power control bits.

Parameter	Units	Value
\bar{I}_{or}	dBm/1.23 MHz	-104
$\frac{Pilot E_c}{I_{or}}$	dB	-7
$\frac{Traffic E_c}{I_{or}}$	dB	-7.4



Table 5-1
Parameters for Max. Power for RC1

Parameter	Units	Value
\bar{I}_{or}	dBm/1.23 MHz	-86
$\frac{Pilot E_c}{I_{or}}$	dB	-7
$\frac{Traffic E_c}{I_{or}}$	dB	-7.4

Table 5-2
Parameters for Max. Power for RC3

Band	Channel	CDMA2000 RC	SO2 Loopback	SO55 Loopback	TDSO SO32 Loopback
Cellular	1013	RC1	24.10	24.10	
		RC3	24.10	24.12	24.10
	384	RC1	24.18	24.10	
		RC3	24.20	24.20	24.20
	777	RC1	24.00	24.00	
		RC3	24.08	24.05	24.00
PCS	25	RC1	24.09	24.10	
		RC3	24.10	24.10	24.11
	600	RC1	24.10	24.20	
		RC3	24.11	24.26	24.30
	1175	RC1	24.00	24.00	
		RC3	24.02	24.03	24.03

Table 5-3
Maximum Power Output Table for AX490

PCTEST™ PT. 22/24 TEST REPORT		FCC MEASUREMENT REPORT		Reviewed by: Quality Manager
Test Report S/N: 0604200307	Test Dates: May 8 - 9, 2006	EUT Type: Tri-Mode Dual-Band Analog/ PCS Phone (AMPS/ CDMA) with Bluetooth	FCC ID: BEJAX490	Page 12 of 34

6.0 EFFECTIVE RADIATED POWER

6.1 Effective Radiated Power Output Data

POWER: High (Analog Mode)

Freq. Tuned (MHz)	REF. LEVEL (dBm)	POL (H/V)	ERP (W)	ERP (dBm)	BATTERY
824.04	-15.260	H	0.399	26.013	Standard
836.52	-15.001	H	0.439	26.428	Standard
848.97	-15.376	H	0.418	26.209	Standard
836.52	-15.040	H	0.435	26.389	Extended



Note: Standard and extended batteries are options for this phone.

NOTES:

Effective Radiated Power Output Measurements by Substitution Method according to ANSI/TIA/EIA-603-A-2001, Aug. 15, 2001:

The EUT was placed on a wooden turn table 3-meters from the receive antenna. The receive antenna height and turntable rotation was adjusted for the highest reading on the receive spectrum analyzer. For CDMA signals, a peak detector is used, with RBW = VBW = 3 MHz. For AMPS, GSM, and NADC TDMA signals, a peak detector is used, with RBW = VBW = 1 MHz. A half-wave dipole was substituted in place of the EUT. This dipole antenna was driven by a signal generator and the level of the signal generator was adjusted to obtain the same receive spectrum analyzer reading. The conducted power at the terminals of the dipole is measured. The ERP is recorded.

This device was tested under all R.C.s and S.O.s and the worst case is reported with RC3/SO55, with "All Up" power control bits.

PCTEST™ PT. 22/24 TEST REPORT		FCC MEASUREMENT REPORT		Reviewed by: Quality Manager
Test Report S/N: 0604200307	Test Dates: May 8 - 9, 2006	EUT Type: Tri-Mode Dual-Band Analog/ PCS Phone (AMPS/ CDMA) with Bluetooth	FCC ID: BEJAX490	Page 13 of 34

6.1 Effective Radiated Power Output Data (Cont'd)

POWER: High (CDMA Mode)

Freq. Tuned (MHz)	REF. LEVEL (dBm)	POL (H/V)	ERP (W)	ERP (dBm)	BATTERY
824.70	-16.740	H	0.284	24.533	Standard
836.52	-17.430	H	0.251	24.003	Standard
848.31	-17.360	H	0.264	24.223	Standard
824.70	-16.850	H	0.277	24.423	Extended



Note: Standard and extended batteries are options for this phone.

NOTES:

Effective Radiated Power Output Measurements by Substitution Method according to ANSI/TIA/EIA-603-A-2001, Aug. 15, 2001:

The EUT was placed on a wooden turn table 3-meters from the receive antenna. The receive antenna height and turntable rotation was adjusted for the highest reading on the receive spectrum analyzer. For CDMA signals, a peak detector is used, with RBW = VBW = 3 MHz. For AMPS, GSM, and NADC TDMA signals, a peak detector is used, with RBW = VBW = 1 MHz. A half-wave dipole was substituted in place of the EUT. This dipole antenna was driven by a signal generator and the level of the signal generator was adjusted to obtain the same receive spectrum analyzer reading. The conducted power at the terminals of the dipole is measured. The ERP is recorded.

This device was tested under all R.C.s and S.O.s and the worst case is reported with RC3/SO55, with "All Up" power control bits.

PCTEST™ PT. 22/24 TEST REPORT		FCC MEASUREMENT REPORT		Reviewed by: Quality Manager
Test Report S/N: 0604200307	Test Dates: May 8 - 9, 2006	EUT Type: Tri-Mode Dual-Band Analog/ PCS Phone (AMPS/ CDMA) with Bluetooth	FCC ID: BEJAX490	Page 14 of 34

7.0 EQUIVALENT ISOTROPIC RADIATED POWER

7.1 Equivalent Isotropic Radiated Power Output Data

Radiated measurements at 3 meters

Supply Voltage: 3.7 VDC

Modulation: PCS CDMA

FREQ. (MHz)	REF. LEVEL (dBm)	POL (H/V)	Azimuth (o angle)	EIRP (dBm)	EIRP (W)	Battery
1851.25	-18.970	H	95	24.111	0.258	Standard
1880.00	-18.850	H	95	24.401	0.275	Standard
1908.75	-19.060	H	95	24.361	0.273	Standard
1880.00	-18.910	H	95	24.341	0.272	Extended



Note: Standard and extended batteries are options for this phone

NOTES:

Equivalent Isotropic Radiated Power Measurements by Substitution Method according to ANSI/TIA/EIA-603-A-2001, Aug. 15, 2001:

The EUT was placed on a wooden turn table 3-meters from the receive antenna. The receive antenna height and turntable rotation was adjusted for the highest reading on the receive spectrum analyzer. For CDMA signals, a peak detector is used, with RBW = VBW = 3 MHz. For AMPS, GSM, and NADC TDMA signals, a peak detector is used, with RBW = VBW = 1 MHz. A Horn antenna was substituted in place of the EUT. This Horn antenna was driven by a signal generator and the level of the signal generator was adjusted to obtain the same receive spectrum analyzer reading. The conducted power at the terminals of the Horn antenna is measured. The difference between the gain of the horn and an isotropic antenna is taken into consideration and the EIRP is recorded.

This device was tested under all R.C.s and S.O.s and the worst case is reported with RC3/SO55, with "All Up" power control bits.

PCTEST™ PT. 22/24 TEST REPORT		FCC MEASUREMENT REPORT		Reviewed by: Quality Manager
Test Report S/N: 0604200307	Test Dates: May 8 - 9, 2006	EUT Type: Tri-Mode Dual-Band Analog/ PCS Phone (AMPS/ CDMA) with Bluetooth	FCC ID: BEJAX490	Page 15 of 34

8.0 RADIATED MEASUREMENTS

8.1 AMPS Radiated Measurements

Field Strength of SPURIOUS Radiation

OPERATING FREQUENCY: 824.04 MHz
 CHANNEL: 0991 (Low)
 MEASURED OUTPUT POWER: 26.428 dBm = 0.439 W
 MODULATION SIGNAL: FM (Internal)
 DISTANCE: 3 meters
 LIMIT: $43 + 10 \log_{10}(W) =$ 39.43 dBc



FREQ. (MHz)	LEVEL @ ANTENNA TERMINALS (dBm)	SUBSTITUTE ANTENNA GAIN (dBd)	CORRECT GENERATOR LEVEL (dBm)	POL (H/V)	(dBc)
1648.08	-31.83	6.10	-25.73	H	52.2
2472.12	-44.65	6.70	-37.95	V	64.4
3296.16	-33.49	6.80	-26.69	H	53.1
4120.20	-50.38	6.50	-43.88	H	70.3
4944.24	-43.38	7.00	-36.38	V	62.8

NOTES:

Radiated Spurious Emission Measurements by Substitution Method
 according to ANSI/TIA/EIA-603-A-2001, Aug. 15, 2001:

The EUT was placed on a wooden turn table 3-meters from the receive antenna. The receive antenna height and turntable rotation was adjusted for the highest reading on the receive spectrum analyzer. For CDMA signals, a peak detector is used, with RBW = VBW = 3 MHz. For AMPS, GSM, and NADC TDMA signals, a peak detector is used, with RBW = VBW = 1 MHz. A half-wave dipole was substituted in place of the EUT. This dipole antenna was driven by a signal generator and the level of the signal generator was adjusted to obtain the same receive spectrum analyzer reading. This spurious level is recorded. For readings above 1GHz, the above procedure is repeated using horn antennas and the difference between the gain of the horn and an isotropic or dipole antenna are taken into consideration.

This device was tested under all R.C.s and S.O.s and the worst case is reported with RC3/SO55, with "All Up" power control bits.

PCTEST™ PT. 22/24 TEST REPORT		FCC MEASUREMENT REPORT		Reviewed by: Quality Manager
Test Report S/N: 0604200307	Test Dates: May 8 - 9, 2006	EUT Type: Tri-Mode Dual-Band Analog/ PCS Phone (AMPS/ CDMA) with Bluetooth	FCC ID: BEJAX490	Page 16 of 34

8.1 AMPS Radiated Measurements (Cont'd)

Field Strength of SPURIOUS Radiation

OPERATING FREQUENCY: 836.52 MHz
 CHANNEL: 0384 (Mid)
 MEASURED OUTPUT POWER: 26.428 dBm = 0.439 W
 MODULATION SIGNAL: FM (Internal)
 DISTANCE: 3 meters
 LIMIT: $43 + 10 \log_{10}(W) =$ 39.43 dBc



FREQ. (MHz)	LEVEL @ ANTENNA TERMINALS (dBm)	SUBSTITUTE ANTENNA GAIN (dBd)	CORRECT GENERATOR LEVEL (dBm)	POL (H/V)	(dBc)
1673.04	-34.53	6.10	-28.43	V	54.9
2509.56	-42.36	6.70	-35.66	V	62.1
3346.08	-33.90	6.80	-27.10	H	53.5
4182.60	-63.01	6.50	-56.51	H	82.9
5019.12	-44.70	7.00	-37.70	V	64.1

NOTES:

Radiated Spurious Emission Measurements by Substitution Method according to ANSI/TIA/EIA-603-A-2001, Aug. 15, 2001:

The EUT was placed on a wooden turn table 3-meters from the receive antenna. The receive antenna height and turntable rotation was adjusted for the highest reading on the receive spectrum analyzer. For CDMA signals, a peak detector is used, with RBW = VBW = 3 MHz. For AMPS, GSM, and NADC TDMA signals, a peak detector is used, with RBW = VBW = 1 MHz. A half-wave dipole was substituted in place of the EUT. This dipole antenna was driven by a signal generator and the level of the signal generator was adjusted to obtain the same receive spectrum analyzer reading. This spurious level is recorded. For readings above 1GHz, the above procedure is repeated using horn antennas and the difference between the gain of the horn and an isotropic or dipole antenna are taken into consideration.

This device was tested under all R.C.s and S.O.s and the worst case is reported with RC3/SO55, with "All Up" power control bits.

PCTEST™ PT. 22/24 TEST REPORT		FCC MEASUREMENT REPORT		Reviewed by: Quality Manager
Test Report S/N: 0604200307	Test Dates: May 8 - 9, 2006	EUT Type: Tri-Mode Dual-Band Analog/ PCS Phone (AMPS/ CDMA) with Bluetooth	FCC ID: BEJAX490	Page 17 of 34

8.1 AMPS Radiated Measurements (Cont'd)

Field Strength of SPURIOUS Radiation

OPERATING FREQUENCY: 848.97 MHz
 CHANNEL: 0799 (High)
 MEASURED OUTPUT POWER: 26.428 dBm = 0.439 W
 MODULATION SIGNAL: FM (Internal)
 DISTANCE: 3 meters
 LIMIT: $43 + 10 \log_{10}(W) =$ 39.43 dBc



FREQ. (MHz)	LEVEL @ ANTENNA TERMINALS (dBm)	SUBSTITUTE ANTENNA GAIN (dBd)	CORRECT GENERATOR LEVEL (dBm)	POL (H/V)	(dBc)
1697.94	-29.34	6.10	-23.24	V	49.7
2546.91	-42.66	6.70	-35.96	H	62.4
3395.88	-32.91	6.80	-26.11	V	52.5
4244.85	-54.35	6.50	-47.85	H	74.3
5093.82	-53.64	7.00	-46.64	H	73.1

NOTES:

Radiated Spurious Emission Measurements by Substitution Method according to ANSI/TIA/EIA-603-A-2001, Aug. 15, 2001:

The EUT was placed on a wooden turn table 3-meters from the receive antenna. The receive antenna height and turntable rotation was adjusted for the highest reading on the receive spectrum analyzer. For CDMA signals, a peak detector is used, with RBW = VBW = 3 MHz. For AMPS, GSM, and NADC TDMA signals, a peak detector is used, with RBW = VBW = 1 MHz. A half-wave dipole was substituted in place of the EUT. This dipole antenna was driven by a signal generator and the level of the signal generator was adjusted to obtain the same receive spectrum analyzer reading. This spurious level is recorded. For readings above 1GHz, the above procedure is repeated using horn antennas and the difference between the gain of the horn and an isotropic or dipole antenna are taken into consideration.

This device was tested under all R.C.s and S.O.s and the worst case is reported with RC3/SO55, with "All Up" power control bits.

PCTEST™ PT. 22/24 TEST REPORT		FCC MEASUREMENT REPORT		Reviewed by: Quality Manager
Test Report S/N: 0604200307	Test Dates: May 8 - 9, 2006	EUT Type: Tri-Mode Dual-Band Analog/ PCS Phone (AMPS/ CDMA) with Bluetooth	FCC ID: BEJAX490	Page 18 of 34

8.2 Cellular CDMA Radiated Measurements

Field Strength of SPURIOUS Radiation

OPERATING FREQUENCY: 824.70 MHz
 CHANNEL: 1013 (Low)
 MEASURED OUTPUT POWER: 24.533 dBm = 0.284 W
 MODULATION SIGNAL: CDMA (Internal)
 DISTANCE: 3 meters
 LIMIT: $43 + 10 \log_{10}(W) =$ 37.53 dBc



FREQ. (MHz)	LEVEL @ ANTENNA TERMINALS (dBm)	SUBSTITUTE ANTENNA GAIN (dBd)	CORRECT GENERATOR LEVEL (dBm)	POL (H/V)	(dBc)
1649.40	-41.33	6.10	-35.23	V	59.8
2474.10	-56.15	6.70	-49.45	V	74.0
3298.80	-42.89	6.80	-36.09	H	60.6
4123.50	-63.58	6.50	-57.08	H	81.6
4948.20	-60.58	7.00	-53.58	V	78.1

NOTES:

Radiated Spurious Emission Measurements by Substitution Method according to ANSI/TIA/EIA-603-A-2001, Aug. 15, 2001:

The EUT was placed on a wooden turn table 3-meters from the receive antenna. The receive antenna height and turntable rotation was adjusted for the highest reading on the receive spectrum analyzer. For CDMA signals, a peak detector is used, with RBW = VBW = 3 MHz. For AMPS, GSM, and NADC TDMA signals, a peak detector is used, with RBW = VBW = 1 MHz. A half-wave dipole was substituted in place of the EUT. This dipole antenna was driven by a signal generator and the level of the signal generator was adjusted to obtain the same receive spectrum analyzer reading. This spurious level is recorded. For readings above 1GHz, the above procedure is repeated using horn antennas and the difference between the gain of the horn and an isotropic or dipole antenna are taken into consideration.

This device was tested under all R.C.s and S.O.s and the worst case is reported with RC3/SO55, with "All Up" power control bits.

PCTEST™ PT. 22/24 TEST REPORT		FCC MEASUREMENT REPORT		Reviewed by: Quality Manager
Test Report S/N: 0604200307	Test Dates: May 8 - 9, 2006	EUT Type: Tri-Mode Dual-Band Analog/ PCS Phone (AMPS/ CDMA) with Bluetooth	FCC ID: BEJAX490	Page 19 of 34

8.2 Cellular CDMA Radiated Measurements (Cont'd)

Field Strength of SPURIOUS Radiation

OPERATING FREQUENCY: 836.52 MHz
 CHANNEL: 0384 (Mid)
 MEASURED OUTPUT POWER: 24.533 dBm = 0.284 W
 MODULATION SIGNAL: CDMA (Internal)
 DISTANCE: 3 meters
 LIMIT: $43 + 10 \log_{10}(W) =$ 37.53 dBc



FREQ. (MHz)	LEVEL @ ANTENNA TERMINALS (dBm)	SUBSTITUTE ANTENNA GAIN (dBd)	CORRECT GENERATOR LEVEL (dBm)	POL (H/V)	(dBc)
1673.04	-43.23	6.10	-37.13	V	61.7
2509.56	-57.56	6.70	-50.86	H	75.4
3346.08	-46.10	6.80	-39.30	V	63.8
4182.60	-61.11	6.50	-54.61	H	79.1
5019.12	-58.60	7.00	-51.60	V	76.1

NOTES:

Radiated Spurious Emission Measurements by Substitution Method according to ANSI/TIA/EIA-603-A-2001, Aug. 15, 2001:

The EUT was placed on a wooden turn table 3-meters from the receive antenna. The receive antenna height and turntable rotation was adjusted for the highest reading on the receive spectrum analyzer. For CDMA signals, a peak detector is used, with RBW = VBW = 3 MHz. For AMPS, GSM, and NADC TDMA signals, a peak detector is used, with RBW = VBW = 1 MHz. A half-wave dipole was substituted in place of the EUT. This dipole antenna was driven by a signal generator and the level of the signal generator was adjusted to obtain the same receive spectrum analyzer reading. This spurious level is recorded. For readings above 1GHz, the above procedure is repeated using horn antennas and the difference between the gain of the horn and an isotropic or dipole antenna are taken into consideration.

This device was tested under all R.C.s and S.O.s and the worst case is reported with RC3/SO55, with "All Up" power control bits.

PCTEST™ PT. 22/24 TEST REPORT		FCC MEASUREMENT REPORT		Reviewed by: Quality Manager
Test Report S/N: 0604200307	Test Dates: May 8 - 9, 2006	EUT Type: Tri-Mode Dual-Band Analog/ PCS Phone (AMPS/ CDMA) with Bluetooth	FCC ID: BEJAX490	Page 20 of 34

8.2 Cellular CDMA Radiated Measurements (Cont'd)

Field Strength of SPURIOUS Radiation

OPERATING FREQUENCY: 848.31 MHz
 CHANNEL: 0777 (High)
 MEASURED OUTPUT POWER: 24.533 dBm = 0.284 W
 MODULATION SIGNAL: CDMA (Internal)
 DISTANCE: 3 meters
 LIMIT: $43 + 10 \log_{10} (W) =$ 37.53 dBc



FREQ. (MHz)	LEVEL @ ANTENNA TERMINALS (dBm)	SUBSTITUTE ANTENNA GAIN (dBd)	CORRECT GENERATOR LEVEL (dBm)	POL (H/V)	(dBc)
1696.62	-39.34	6.10	-33.24	V	57.8
2544.93	-55.66	6.70	-48.96	V	73.5
3393.24	-44.71	6.80	-37.91	H	62.4
4241.55	-61.85	6.50	-55.35	H	79.9
5089.86	-57.24	7.00	-50.24	H	74.8

NOTES:

Radiated Spurious Emission Measurements by Substitution Method according to ANSI/TIA/EIA-603-A-2001, Aug. 15, 2001:

The EUT was placed on a wooden turn table 3-meters from the receive antenna. The receive antenna height and turntable rotation was adjusted for the highest reading on the receive spectrum analyzer. For CDMA signals, a peak detector is used, with RBW = VBW = 3 MHz. For AMPS, GSM, and NADC TDMA signals, a peak detector is used, with RBW = VBW = 1 MHz. A half-wave dipole was substituted in place of the EUT. This dipole antenna was driven by a signal generator and the level of the signal generator was adjusted to obtain the same receive spectrum analyzer reading. This spurious level is recorded. For readings above 1GHz, the above procedure is repeated using horn antennas and the difference between the gain of the horn and an isotropic or dipole antenna are taken into consideration.

This device was tested under all R.C.s and S.O.s and the worst case is reported with RC3/SO55, with "All Up" power control bits.

PCTEST™ PT. 22/24 TEST REPORT		FCC MEASUREMENT REPORT		Reviewed by: Quality Manager
Test Report S/N: 0604200307	Test Dates: May 8 - 9, 2006	EUT Type: Tri-Mode Dual-Band Analog/ PCS Phone (AMPS/ CDMA) with Bluetooth	FCC ID: BEJAX490	Page 21 of 34

8.3 PCS CDMA Radiated Measurements

Field Strength of SPURIOUS Radiation

OPERATING FREQUENCY: 1851.25 MHz
 CHANNEL: 0025 (Low)
 MEASURED OUTPUT POWER: 24.401 dBm = 0.275 W
 MODULATION SIGNAL: CDMA (Internal)
 DISTANCE: 3 meters
 LIMIT: $43 + 10 \log_{10}(W) =$ 37.40 dBc



FREQ. (MHz)	LEVEL @ ANTENNA TERMINALS (dBm)	SUBSTITUTE ANTENNA GAIN (dBi)	CORRECT GENERATOR LEVEL (dBm)	POL (H/V)	(dBc)
3702.50	-43.75	8.70	-35.05	H	59.5
5553.75	-45.90	9.70	-36.20	V	60.6
7405.00	-41.02	9.90	-31.12	H	55.5
9256.25	-77.43	11.40	-66.03	V	90.4
11107.50	-77.33	12.10	-65.23	H	89.6

NOTES:

Radiated Spurious Emission Measurements by Substitution Method according to ANSI/TIA/EIA-603-A-2001, Aug. 15, 2001:

The EUT was placed on a wooden turn table 3-meters from the receive antenna. The receive antenna height and turntable rotation was adjusted for the highest reading on the receive spectrum analyzer. For CDMA signals, a peak detector is used, with RBW = VBW = 3 MHz. For AMPS, GSM, and NADC TDMA signals, a peak detector is used, with RBW = VBW = 1 MHz. A half-wave dipole was substituted in place of the EUT. This dipole antenna was driven by a signal generator and the level of the signal generator was adjusted to obtain the same receive spectrum analyzer reading. This spurious level is recorded. For readings above 1GHz, the above procedure is repeated using horn antennas and the difference between the gain of the horn and an isotropic or dipole antenna are taken into consideration.

This device was tested under all R.C.s and S.O.s and the worst case is reported with RC3/SO55, with "All Up" power control bits.

PCTEST™ PT. 22/24 TEST REPORT		FCC MEASUREMENT REPORT		Reviewed by: Quality Manager
Test Report S/N: 0604200307	Test Dates: May 8 - 9, 2006	EUT Type: Tri-Mode Dual-Band Analog/ PCS Phone (AMPS/ CDMA) with Bluetooth	FCC ID: BEJAX490	Page 22 of 34

8.3 PCS CDMA Radiated Measurements (Cont'd)

Field Strength of SPURIOUS Radiation

OPERATING FREQUENCY: 1880.00 MHz
 CHANNEL: 0600 (Mid)
 MEASURED OUTPUT POWER: 24.401 dBm = 0.275 W
 MODULATION SIGNAL: CDMA (Internal)
 DISTANCE: 3 meters
 LIMIT: $43 + 10 \log_{10}(W) =$ 37.40 dBc



FREQ. (MHz)	LEVEL @ ANTENNA TERMINALS (dBm)	SUBSTITUTE ANTENNA GAIN (dBi)	CORRECT GENERATOR LEVEL (dBm)	POL (H/V)	(dBc)
3760.00	-40.90	8.70	-32.20	H	56.6
5640.00	-52.43	9.70	-42.73	V	67.1
7520.00	-46.13	9.90	-36.23	V	60.6
9400.00	-77.23	11.40	-65.83	H	90.2
11280.00	-77.13	12.10	-65.03	H	89.4

NOTES:

Radiated Spurious Emission Measurements by Substitution Method according to ANSI/TIA/EIA-603-A-2001, Aug. 15, 2001:

The EUT was placed on a wooden turn table 3-meters from the receive antenna. The receive antenna height and turntable rotation was adjusted for the highest reading on the receive spectrum analyzer. For CDMA signals, a peak detector is used, with RBW = VBW = 3 MHz. For AMPS, GSM, and NADC TDMA signals, a peak detector is used, with RBW = VBW = 1 MHz. A half-wave dipole was substituted in place of the EUT. This dipole antenna was driven by a signal generator and the level of the signal generator was adjusted to obtain the same receive spectrum analyzer reading. This spurious level is recorded. For readings above 1GHz, the above procedure is repeated using horn antennas and the difference between the gain of the horn and an isotropic or dipole antenna are taken into consideration.

This device was tested under all R.C.s and S.O.s and the worst case is reported with RC3/SO55, with "All Up" power control bits.

PCTEST™ PT. 22/24 TEST REPORT		FCC MEASUREMENT REPORT		Reviewed by: Quality Manager
Test Report S/N: 0604200307	Test Dates: May 8 - 9, 2006	EUT Type: Tri-Mode Dual-Band Analog/ PCS Phone (AMPS/ CDMA) with Bluetooth	FCC ID: BEJAX490	Page 23 of 34

8.3 PCS CDMA Radiated Measurements (Cont'd)

Field Strength of SPURIOUS Radiation

OPERATING FREQUENCY: 1908.75 MHz
 CHANNEL: 1175 (High)
 MEASURED OUTPUT POWER: 24.401 dBm = 0.275 W
 MODULATION SIGNAL: CDMA (Internal)
 DISTANCE: 3 meters
 LIMIT: $43 + 10 \log_{10} (W) =$ 37.40 dBc



FREQ. (MHz)	LEVEL @ ANTENNA TERMINALS (dBm)	SUBSTITUTE ANTENNA GAIN (dBi)	CORRECT GENERATOR LEVEL (dBm)	POL (H/V)	(dBc)
3817.50	-38.84	8.70	-30.14	H	54.5
5726.25	-39.62	9.70	-29.92	H	54.3
7635.00	-50.70	9.90	-40.80	V	65.2
9543.75	-76.93	11.40	-65.53	V	89.9
11452.50	-76.93	12.10	-64.83	H	89.2

NOTES:

Radiated Spurious Emission Measurements by Substitution Method according to ANSI/TIA/EIA-603-A-2001, Aug. 15, 2001:

The EUT was placed on a wooden turn table 3-meters from the receive antenna. The receive antenna height and turntable rotation was adjusted for the highest reading on the receive spectrum analyzer. For CDMA signals, a peak detector is used, with RBW = VBW = 3 MHz. For AMPS, GSM, and NADC TDMA signals, a peak detector is used, with RBW = VBW = 1 MHz. A half-wave dipole was substituted in place of the EUT. This dipole antenna was driven by a signal generator and the level of the signal generator was adjusted to obtain the same receive spectrum analyzer reading. This spurious level is recorded. For readings above 1GHz, the above procedure is repeated using horn antennas and the difference between the gain of the horn and an isotropic or dipole antenna are taken into consideration.

This device was tested under all R.C.s and S.O.s and the worst case is reported with RC3/SO55, with "All Up" power control bits.

PCTEST™ PT. 22/24 TEST REPORT		FCC MEASUREMENT REPORT		Reviewed by: Quality Manager
Test Report S/N: 0604200307	Test Dates: May 8 - 9, 2006	EUT Type: Tri-Mode Dual-Band Analog/ PCS Phone (AMPS/ CDMA) with Bluetooth	FCC ID: BEJAX490	Page 24 of 34

9.0 FREQUENCY STABILITY

9.1 Frequency Stability (AMPS)



OPERATING FREQUENCY: 836,490,007 Hz

CHANNEL: 383

REFERENCE VOLTAGE: 3.7 VDC



DEVIATION LIMIT: ± 0.00025 % or 2.5 ppm

VOLTAGE (%)	POWER (VDC)	TEMP (°C)	FREQ. (Hz)	Freq. Dev. (Hz)	Deviation (%)
100 %	3.70	+ 20 (Ref)	836,490,007	0.00	0.000000
100 %		-30	836,489,940	66.92	0.000008
100 %		-20	836,489,932	75.28	0.000009
100 %		-10	836,489,990	16.73	0.000002
100 %		0	836,490,066	-58.55	-0.000007
100 %		10	836,490,040	-33.46	-0.000004
100 %		20	836,490,007	0.00	0.000000
100 %		25	836,489,974	33.46	0.000004
100 %		30	836,490,049	-41.82	-0.000005
100 %		40	836,490,040	-33.46	-0.000004
100 %		50	836,490,057	-50.19	-0.000006
100 %		60	836,490,040	-33.46	-0.000004
85 %		3.17	20	836,490,007	0.00
115 %	4.26	20	836,490,007	0.00	0.000000
BATT. ENDPOINT	3.06	20	836,490,007	0.00	0.000000

PCTEST™ PT. 22/24 TEST REPORT		FCC MEASUREMENT REPORT		Reviewed by: Quality Manager
Test Report S/N: 0604200307	Test Dates: May 8 - 9, 2006	EUT Type: Tri-Mode Dual-Band Analog/ PCS Phone (AMPS/ CDMA) with Bluetooth	FCC ID: BEJAX490	Page 25 of 34

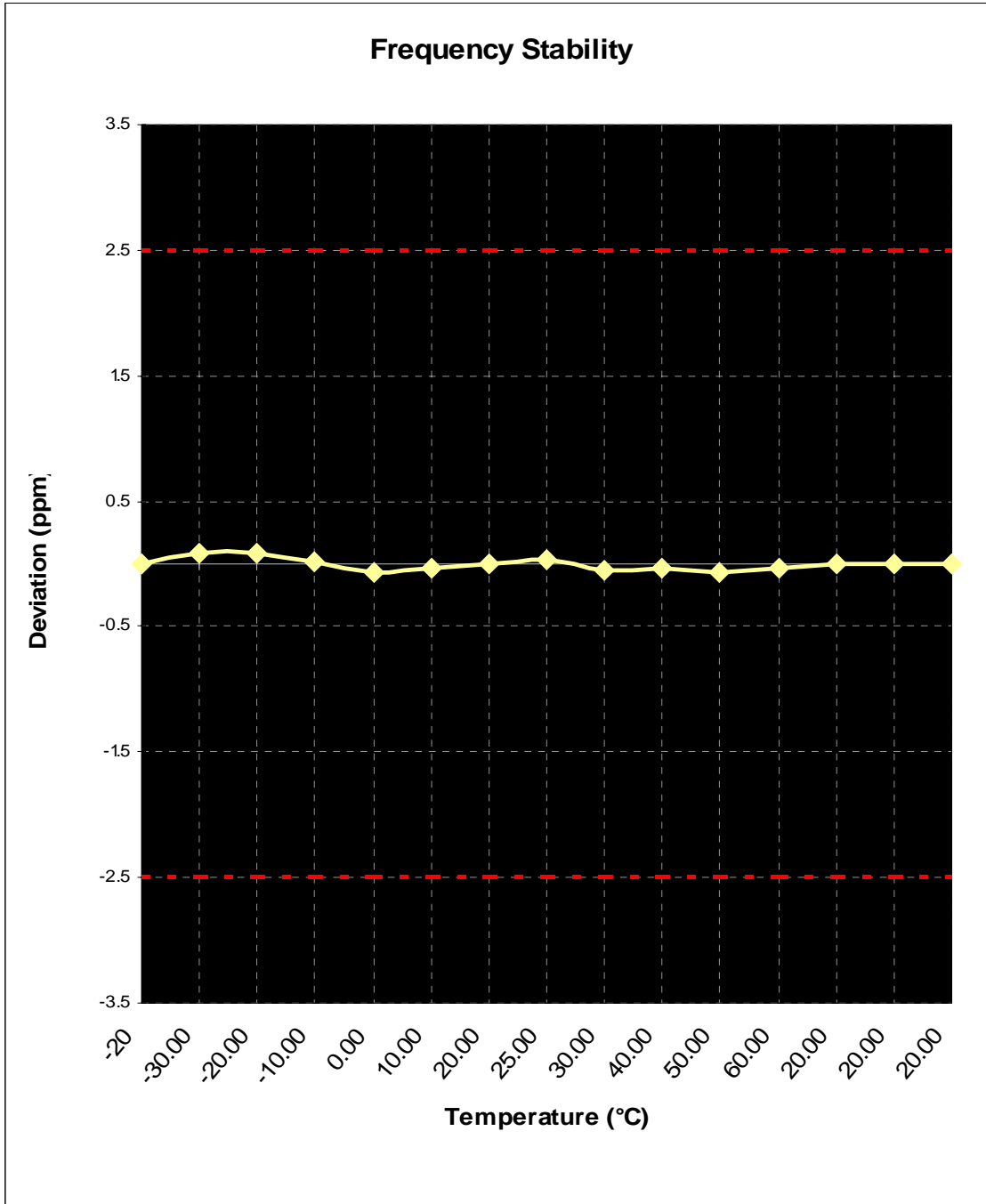
9.1 Frequency Stability (AMPS) (Cont'd)



PCTEST™ PT. 22/24 TEST REPORT		FCC MEASUREMENT REPORT		Reviewed by: Quality Manager
Test Report S/N: 0604200307	Test Dates: May 8 - 9, 2006	EUT Type: Tri-Mode Dual-Band Analog/ PCS Phone (AMPS/ CDMA) with Bluetooth	FCC ID: BEJAX490	Page 26 of 34

9.2 Frequency Stability (Cellular CDMA)



OPERATING FREQUENCY: 836,520,009 Hz

CHANNEL: 384

REFERENCE VOLTAGE: 3.7 VDC



DEVIATION LIMIT: ± 0.00025 % or 2.5 ppm

VOLTAGE (%)	POWER (VDC)	TEMP (°C)	FREQ. (Hz)	Freq. Dev. (Hz)	Deviation (%)
100 %	3.70	+ 20 (Ref)	836,520,009	0.00	0.000000
100 %		-30	836,519,976	33.46	0.000004
100 %		-20	836,519,942	66.92	0.000008
100 %		-10	836,520,017	-8.37	-0.000001
100 %		0	836,520,059	-50.19	-0.000006
100 %		10	836,520,026	-16.73	-0.000002
100 %		20	836,520,009	0.00	0.000000
100 %		25	836,519,884	125.48	0.000015
100 %		30	836,519,942	66.92	0.000008
100 %		40	836,520,001	8.37	0.000001
100 %		50	836,520,042	-33.46	-0.000004
100 %		60	836,519,984	25.10	0.000003
85 %		3.17	20	836,520,009	0.00
115 %	4.26	20	836,520,009	0.00	0.000000
BATT. ENDPOINT	3.08	20	836,520,009	0.00	0.000000

PCTEST™ PT. 22/24 TEST REPORT		FCC MEASUREMENT REPORT		Reviewed by: Quality Manager
Test Report S/N: 0604200307	Test Dates: May 8 - 9, 2006	EUT Type: Tri-Mode Dual-Band Analog/ PCS Phone (AMPS/ CDMA) with Bluetooth	FCC ID: BEJAX490	Page 27 of 34

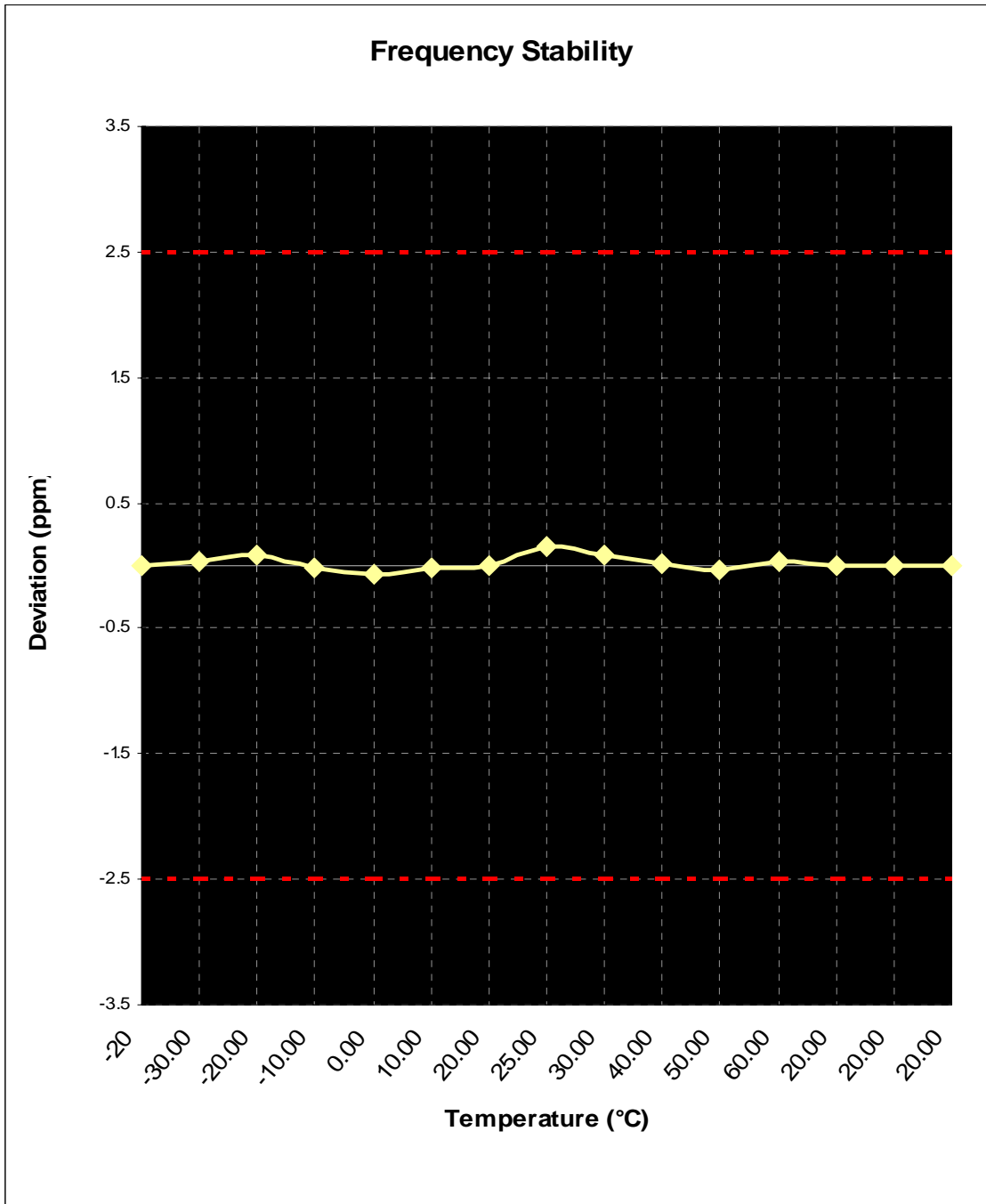
9.2 Frequency Stability (CDMA) (Cont'd)



PCTEST™ PT. 22/24 TEST REPORT		FCC MEASUREMENT REPORT		Reviewed by: Quality Manager
Test Report S/N: 0604200307	Test Dates: May 8 - 9, 2006	EUT Type: Tri-Mode Dual-Band Analog/ PCS Phone (AMPS/ CDMA) with Bluetooth	FCC ID: BEJAX490	Page 28 of 34



9.3 Frequency Stability (PCS CDMA)

OPERATING FREQUENCY: 1,880,000,004 Hz

CHANNEL: 600

REFERENCE VOLTAGE: 3.7 VDC



DEVIATION LIMIT: ± 0.00025 % or 2.5 ppm

VOLTAGE (%)	POWER (VDC)	TEMP (°C)	FREQ. (Hz)	Freq. Dev. (Hz)	Deviation (%)
100 %	3.70	+ 20 (Ref)	1,880,000,004	0.00	0.000000
100 %		-30	1,879,999,854	150.40	0.000008
100 %		-20	1,879,999,929	75.20	0.000004
100 %		-10	1,880,000,136	-131.60	-0.000007
100 %		0	1,880,000,286	-282.00	-0.000015
100 %		10	1,880,000,211	-206.80	-0.000011
100 %		20	1,880,000,004	0.00	0.000000
100 %		25	1,880,000,098	-94.00	-0.000005
100 %		30	1,879,999,948	56.40	0.000003
100 %		40	1,879,999,854	150.40	0.000008
100 %		50	1,879,999,891	112.80	0.000006
100 %		60	1,879,999,948	56.40	0.000003
85 %		3.15	20	1,880,000,004	0.00
115 %	4.26	20	1,880,000,004	0.00	0.000000
BATT. ENDPOINT	3.10	20	1,880,000,004	0.00	0.000000

PCTEST™ PT. 22/24 TEST REPORT		FCC MEASUREMENT REPORT		Reviewed by: Quality Manager
Test Report S/N: 0604200307	Test Dates: May 8 - 9, 2006	EUT Type: Tri-Mode Dual-Band Analog/ PCS Phone (AMPS/ CDMA) with Bluetooth	FCC ID: BEJAX490	Page 29 of 34

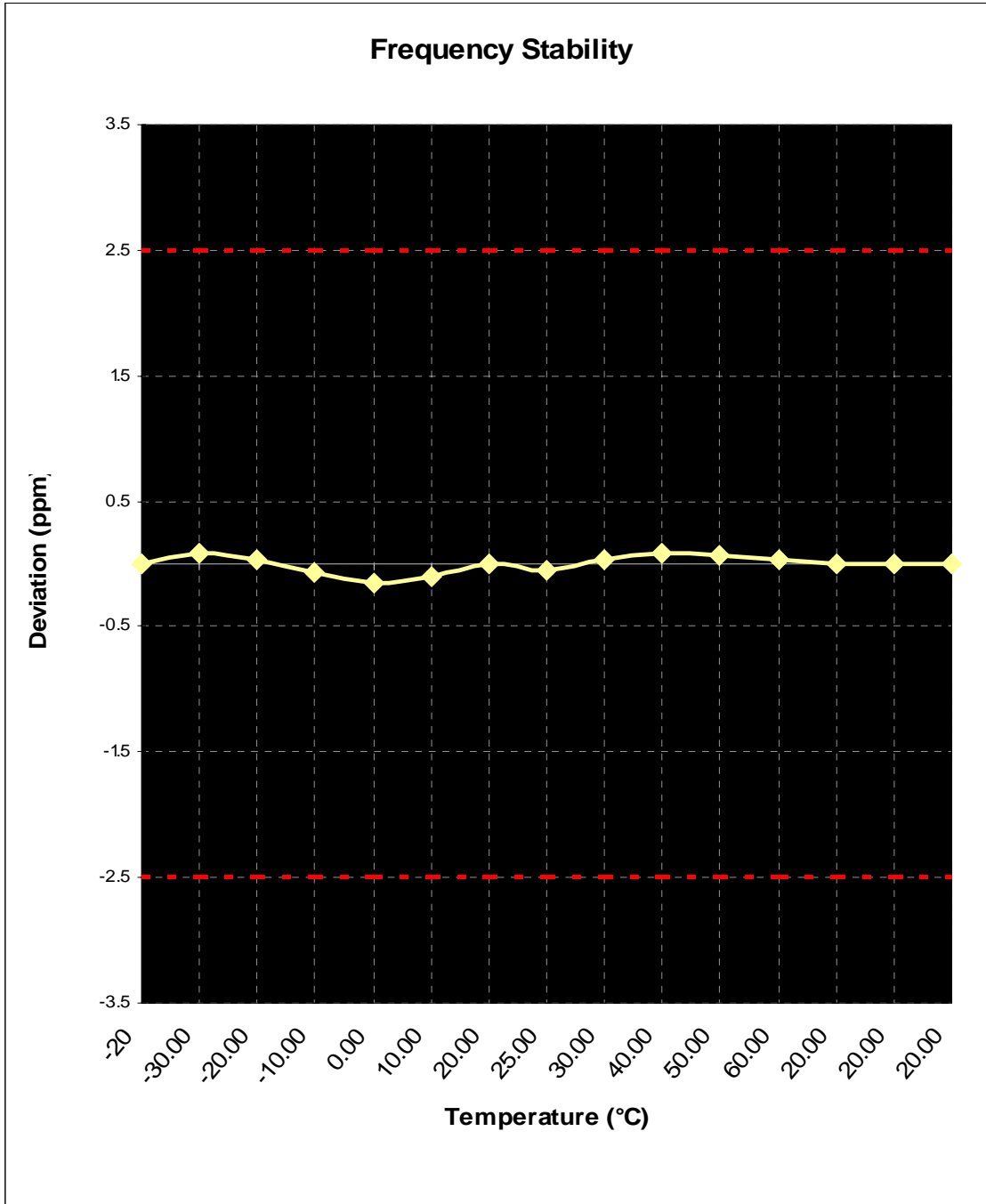

9.3 Frequency Stability (PCS CDMA) (Cont'd)



PCTEST™ PT. 22/24 TEST REPORT		FCC MEASUREMENT REPORT		Reviewed by: Quality Manager
Test Report S/N: 0604200307	Test Dates: May 8 - 9, 2006	EUT Type: Tri-Mode Dual-Band Analog/ PCS Phone (AMPS/ CDMA) with Bluetooth	FCC ID: BEJAX490	Page 30 of 34



10.0 PLOT(S) OF EMISSIONS

(SEE ATTACHMENT D)

PCTEST™ PT. 22/24 TEST REPORT		FCC MEASUREMENT REPORT		Reviewed by: Quality Manager
Test Report S/N: 0604200307	Test Dates: May 8 - 9, 2006	EUT Type: Tri-Mode Dual-Band Analog/ PCS Phone (AMPS/ CDMA) with Bluetooth	FCC ID: BEJAX490	Page 31 of 34

11.0 TEST EQUIPMENT

TYPE	MODEL	CAL DUE DATE	S/N
Signal Generator	Rohde & Schwarz (0.1-1000MHz)	9/11/2006	894215/012
Ailtech/Eaton Receiver	NM 37/57A-SL (30-1000MHz)	4/12/2007	0792-03271
Ailtech/Eaton Receiver	NM 37/57A (30-1000MHz)	3/11/2007	0805-03334
Ailtech/Eaton Receiver	NM 17/27A (0.1-32MHz)	9/17/2006	0608-03241
Ailtech/Eaton Adapter	CCA-7 CISPR/ANSI QP Adapter	3/11/2007	0194-04082
Harmonic/Flicker	Test System HP 6841A (IEC 555-2/3)	2/11/2007	3531A00115/ PCT468
Shielded Screen Room	RF Lindgren Model 26-2/2-0	6/19/2006	6710 (PCT270)
Shielded Semi-Anechoic Chamber	Ray Proof Model S81	4/17/2007	R2437 (PCT278)
Quasi-Peak Adapter	HP 85650A	8/9/2006	2043A00301
Microwave Spectrum Analyzer	HP 8566B (100Hz-22GHz)	8/15/2006	3638A08713
Microwave Spectrum Analyzer	HP 8566B (100Hz-22GHz)	4/17/2007	2542A11898
Spectrum Analyzer/Tracking Gen.	HP 8591A (100Hz-1.8GHz)	9/12/2006	3144A02458
Signal Generator	HP 8640B (500Hz-1GHz)	6/3/2006	2232A19558
Signal Generator	HP 8640B (500Hz-1GHz)	6/3/2006	1851A09816
Signal Generator	HP 8648D (9kHz-4GHz)	5/1/2007	3613A00315
Spectrum Analyzer	HP 8594A	11/2/2006	3051A00187
Spectrum Analyzer (2)	HP 8591A	10/15/2006	3034A01395, 3108A02053
Audio Analyzer	HP 8903B		3011A09025
Modulation Analyzer	HP 8901A		2432A03467
Power Meter	HP 437B		3125U24437
Power Sensor	HP 8482H (30mW-3W)		2237A02084
Broadband Amplifier (2)	HP 8447D		1145A00470, 1937A03348
Broadband Amplifier	HP 8447F		2443A03784
Network Analyzer	HP 8753E (30kHz-3GHz)		JP38020182
Attenuator	HP 8495A (0-70dB) DC-4GHz		
Horn Antenna	EMCO Model 3115 (1-18GHz)		9704-5182
Horn Antenna	EMCO Model 3115 (1-18GHz)		9205-3874
Horn Antenna	EMCO Model 3116 (18-40GHz)		9203-2178
Biconical Antenna (4)	Eaton 94455/Eaton 94455-1/Singer 94455-1/Compliance Design		1295, 1332, 0355
Log-Spiral Antenna (3)	Ailtech/Eaton 93490-1		0608, 1103, 1104
Roberts Dipoles	Compliance Design (1 set)		
Ailtech Dipoles	DM-105A (1 set)		33448-111
EMCO LISN (6)	3816/2		1079
Microwave Preamplifier 40dB	Gain HP 83017A (0.5-26.5GHz)		3123A00181
Microwave Cables	MicroCoax (1.0-26.5GHz)		
Gigatronics Universal Power Meter	8657A		1835256
Gigatronics Power Sensor	80701A (0.05-18GHz)		1833460
Amplifier Research	5S1G4 (5W, 800MHz-4.2GHz)		22322
Microwave Survey Meter	Holiday Model 1501 (2.450GHz)		80931
Digital Thermometer	Extech Instruments 421305		426966
Bi Directional Coax Coupler	Narda 3020A (50-1000MHz)		
Environmental Chamber	Associated Systems Model 1025 (Temperature/Humidity)		PCT285

PCTEST™ PT. 22/24 TEST REPORT		FCC MEASUREMENT REPORT		Reviewed by: Quality Manager
Test Report S/N: 0604200307	Test Dates: May 8 - 9, 2006	EUT Type: Tri-Mode Dual-Band Analog/ PCS Phone (AMPS/ CDMA) with Bluetooth	FCC ID: BEJAX490	Page 32 of 34

12.0 SAMPLE CALCULATIONS

12.1 Emission Designator

Emission Designator = 1M25F9W

CDMA BW = 1.25 MHz

F = Frequency Modulation

9 = Composite Digital Info

W = Combination (Audio/Data) (Measured at the 99.75% power bandwidth)

Emission Designator = 40K0F8W

Calculation: Voice + SAT

Modulation: Voice is 2.5 kHz and SAT is 6 kHz – Maximum modulation is M = 6 kHz

Deviation: Voice is 12 kHz and SAT is 2 kHz – Maximum deviation is D = 12 + 2 = 14 kHz

Bn = 2xM + 2xDK with K = 1

Bn = 40 kHz

Calculation: Signaling Tone (ST) + SAT

Modulation: ST is 10 kHz and SAT is 6 kHz – Maximum modulation is M = 10 kHz

Deviation: ST is 8 kHz and SAT is 2 kHz – Maximum deviation is D = 8 + 2 = 10 kHz

Bn = 2xM + 2xDK with K = 1

Bn = 40 kHz

Emission Designator = 40K0F1D

Calculation: Voice + SAT

Modulation: Wideband Data is 10 kHz and SAT is 6 kHz – Maximum modulation is M = 10 kHz

Deviation: Wideband Data is 8 kHz and SAT is 2 kHz – Maximum deviation is D = 8 + 2 = 10 kHz



Bn = 2xM + 2xDK with K = 1

Bn = 40 kHz

12.2 Spurious Radiated Emission - PCS Band



Example: Channel 25 PCS Mode 2nd Harmonic (3702.50 MHz)

The receive analyzer reading at 3 meters with the EUT on the turntable was –81.0 dBm. The gain of the substituted antenna is 8.1 dBi. The signal generator connected to the substituted antenna terminals is adjusted to produce a reading of –81.0 dBm on the receive analyzer. The loss of the cable between the signal generator and the terminals of the substituted antenna is 2.0 dB at 3702.50 MHz. So 6.1 dB is added to the signal generator reading of –30.9 dBm yielding –24.80 dBm. The fundamental EIRP was 25.501 dBm so this harmonic was 25.501 dBm – (-24.80) = 50.3 dBc.

PCTEST™ PT. 22/24 TEST REPORT		FCC MEASUREMENT REPORT		Reviewed by: Quality Manager
Test Report S/N: 0604200307	Test Dates: May 8 - 9, 2006	EUT Type: Tri-Mode Dual-Band Analog/ PCS Phone (AMPS/ CDMA) with Bluetooth	FCC ID: BEJAX490	Page 33 of 34

13.0 CONCLUSION

The data collected shows that the LGE Tri-Mode Dual-Band Analog/ PCS Phone (AMPS/ CDMA) with Bluetooth FCC ID: BEJAX490 complies with all the requirements of Parts 2, 22, and 24 of the FCC rules.

PCTEST™ PT. 22/24 TEST REPORT		FCC MEASUREMENT REPORT		Reviewed by: Quality Manager
Test Report S/N: 0604200307	Test Dates: May 8 - 9, 2006	EUT Type: Tri-Mode Dual-Band Analog/ PCS Phone (AMPS/ CDMA) with Bluetooth	FCC ID: BEJAX490	Page 34 of 34

