



東莞偉特
DONGGUAN WITTIS
ELECTRONICS CO.,LTD.

**PRODUCT
SPECIFICATION**

MODEL: RF-VL3412AVS
PAGE: 1
DESCRIPTION: RF MODULATOR

RF-VL3412AVS

RF MODULATOR WITH ANT ATT

| | |
|---|--------------|
| Manufacturer: DONG GUAN WITTIS ELECTRONICS CO.,LTD | |
| PART NO. | RF-VL3412AVS |
| SPEC NO. | |

| | |
|-----------|--|
| CUSTOMER: | |
| PART NO. | |
| SPEC NO. | |

Specifications For Approval:

2001.11.29
6704R-N003A
221815
NTSC 3/4UM
LV-RNS215

[Handwritten signature]
2001.11.22

| APPROVAL | CHECKED | PRESENTED |
|----------|---------|-----------|
| | | |

| REV. | DESCRIPTION | DATE | SIGN |
|------|-----------------------------------|------------|------|
| B | Video Modulation Facto sa LG 80 % | 2001.11.22 | |
| A | Original Release | | |

| DESCRIPTION | APPROVAL | CHECK | DESIGN |
|--------------|----------------|------------|------------|
| | DATE | DATE | DATE |
| RF MODULATOR | 05-18-2001 | 05-18-2001 | 05-08-2001 |
| DRAWING NO. | | | |
| REVISIONS | PAGES TOTAL: 4 | | |



東莞偉特
DONGGUAN WITTIS
ELECTRONICS CO.,LTD.

PRODUCT
SPECIFICATION

MODEL
RF-VL3412AVS

DESCRIPTION
RF MODULATOR

PAGE
4

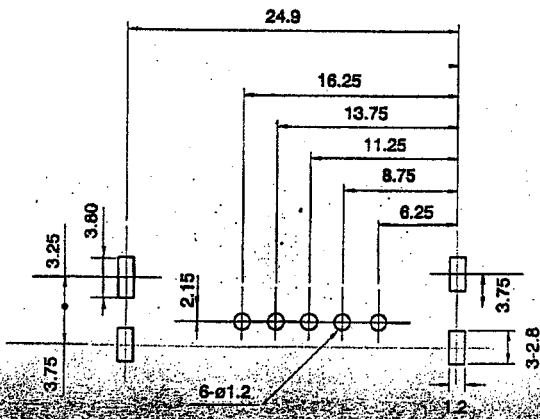
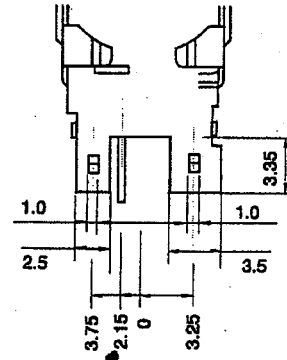
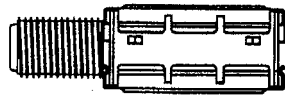
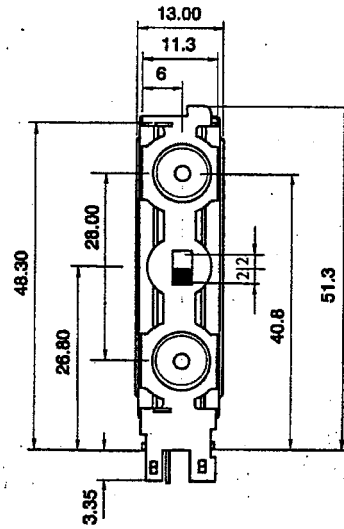
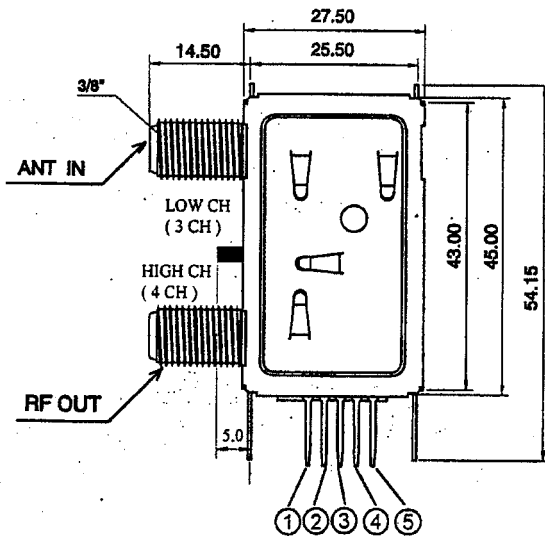
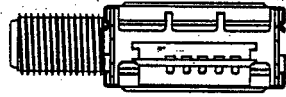

| NO. | FUNCTION |
|-----|-------------------------------------|
| 1 | AUDIO IN |
| 2 | NG |
| 3 | +E : 5V |
| 4 | CT +5V : MOD ON / OPEN : MOD OFF |
| 5 | VIDEO IN |

MODEL - Modulator (with 75) #1, #2, #3, #4, #5

Date: 2001. 11. 6

<RF OUT LEVEL>

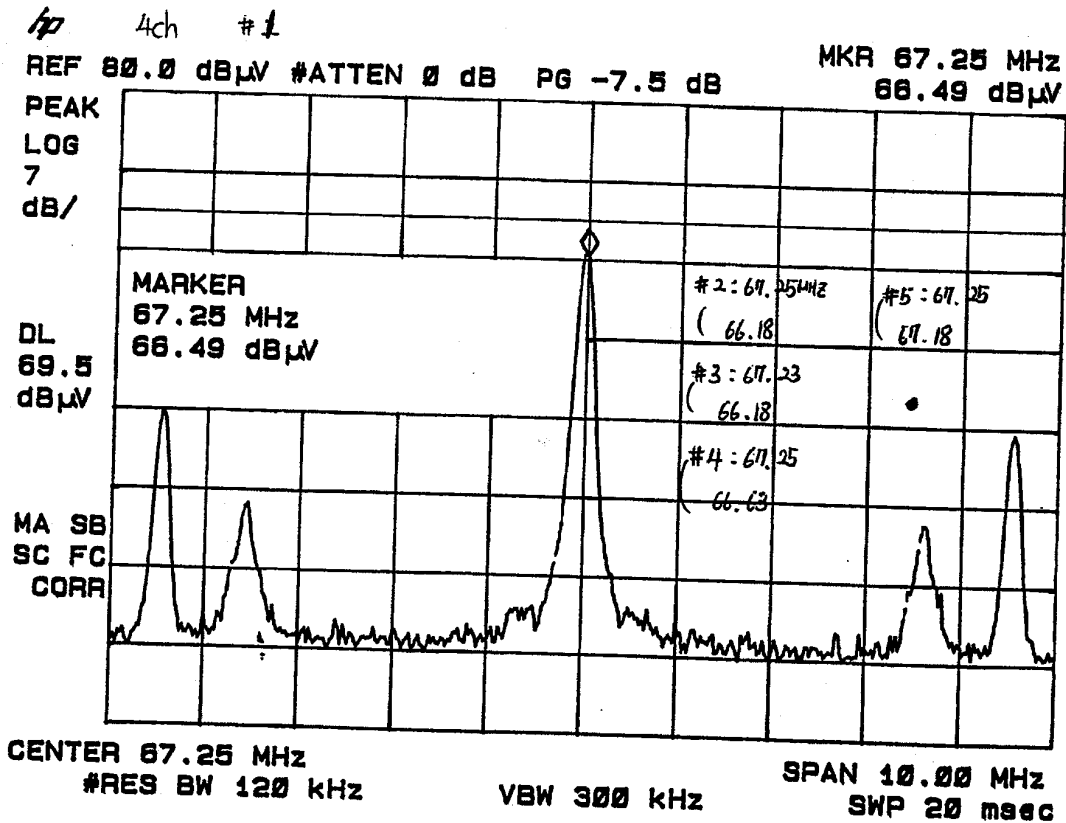
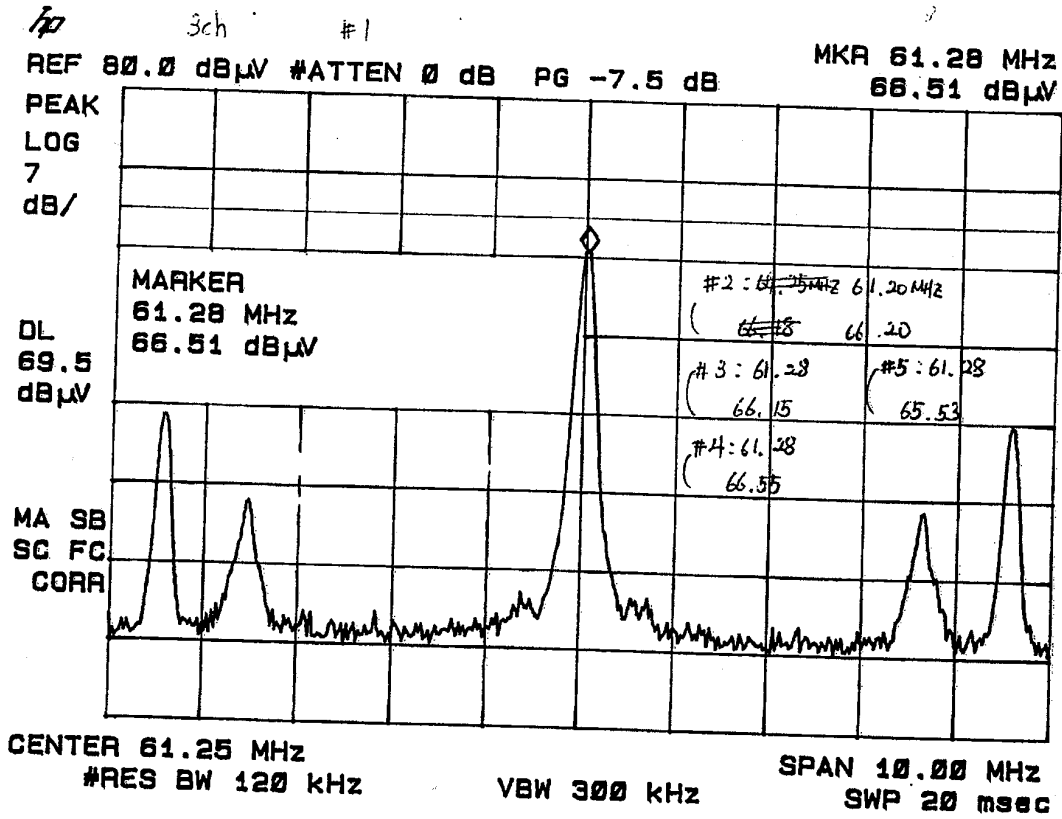

MODEL: Modulator (wittis) #1, #2, #3, #4, #5

Date: 2001. 11. 6

<Isolation>

