

TEST REPORT

of

FCC Part 15 Subpart C §15.247

FCC ID: BEJ9QK-LCF820

Equipment Under Test : CAR CD/MP3/WMA Receiver
Model Name : LCF820BO
Serial No. : N/A
Applicant : LG Electronics USA
Manufacturer : LG Electronics USA
Date of Test(s) : 2012. 01. 16 ~ 2012. 01. 26
Date of Issue : 2012. 02. 23

In the configuration tested, the EUT complied with the standards specified above.

Tested By:



Date

2012. 02. 23

Alvin Kim

Approved By:



Date

2012. 02. 23

Feel Jeong

The results shown in this test report refer only to the sample(s) tested unless otherwise stated. This test report cannot be reproduced, except in full, without prior written permission of the Company.

INDEX

<u>Table of Contents</u>	Page
1. General Information -----	3
2. Transmitter Radiated Spurious Emissions and Conducted Spurious Emission -----	7
3. 20 dB Bandwidth-----	23
4. Maximum Peak Output Power -----	28
5. Hopping Channel Separation -----	30
6. Number of Hopping Frequency -----	33
7. Time of Occupancy(Dwell Time) -----	37
8. Antenna Requirement -----	44
9. RF Exposure evaluation -----	45

The results shown in this test report refer only to the sample(s) tested unless otherwise stated. This test report cannot be reproduced, except in full, without prior written permission of the Company.

1. General Information

1.1. Testing Laboratory

SGS Korea Co., Ltd. (Gunpo Laboratory)

- 413-15, Gomae-Dong Giheung-Gu, Yongin-Si, Gyeonggi-Do, South Korea.
- Wireless Div. 2FL, 18-34, Sanbon-dong, Gunpo-si, Gyeonggi-do, Korea 435-040

www.ee.sgs.com/korea

Telephone : +82 31 428 5700

FAX : +82 31 427 2371

1.2. Details of Applicant

Applicant : LG Electronics USA

Address : 1000 Sylvan Avenue, Englewood Cliffs, New Jersey, USA, 07632

Contact Person : Lee, Kwang-Min

Phone No. : +82 31 610 6648

1.3. Description of EUT

Kind of Product	CAR CD/MP3/WMA Receiver
Model Name	LCF820BO
Serial Number	N/A
Power Supply	DC 12 V (Lead-acid battery power source used on vehicles)
Frequency Range	2 402 MHz ~ 2 480 MHz
Modulation Technique	GFSK, $\pi/4$ DQPSK, 8DPSK
Number of Channels	79
Antenna Type	Internal type (Chip antenna)
Antenna Gain	2.11 dBi

1.4. Declaration by the manufacturer

- N/A

The results shown in this test report refer only to the sample(s) tested unless otherwise stated. This test report cannot be reproduced, except in full, without prior written permission of the Company.

SGS Korea Co., Ltd. (Gunpo Laboratory) 18-34, Sanbon-dong, Gunpo-si, Gyeonggi-do, Korea, 435-040

Tel. +82 31 428 5700 / Fax. +82 31 427 2371

www.ee.sgs.com/korea

1.5. Information about the FHSS characteristics:

1.5.1. Pseudorandom Frequency Hopping Sequence

The channel is represented by a pseudo-random hopping sequence hopping through the 79 RF channels. The hopping sequence is unique for the piconet and is determined by the Bluetooth device address of the master; the phase in the hopping sequence is determined by the Bluetooth clock of the master. The channel is divided into time slots where each slot corresponds to an RF hop frequency. Consecutive hops correspond to different RF hop frequencies. The nominal hop rate is 1 600 hops/s.

1.5.2. Equal Hopping Frequency Use

All Bluetooth units participating in the piconet are time and hop-synchronized to the channel.

1.5.3. System Receiver Input Bandwidth

Each channel bandwidth is 1 MHz

1.5.4. Equipment Description

15.247(g): In accordance with the Bluetooth Industry Standard, the system is designed to comply with all of the regulations in Section 15.247 when the transmitter is presented with a continuous data (or information) system.

15.247(h): In accordance with the Bluetooth Industry Standard, the system does not coordinate its channels selection/ hopping sequence with other frequency hopping systems for the express purpose of avoiding the simultaneous occupancy of individual hopping frequencies by multiple transmitters.

The results shown in this test report refer only to the sample(s) tested unless otherwise stated. This test report cannot be reproduced, except in full, without prior written permission of the Company.

SGS Korea Co., Ltd. (Gunpo Laboratory) 18-34, Sanbon-dong, Gunpo-si, Gyeonggi-do, Korea, 435-040

Tel. +82 31 428 5700 / Fax. +82 31 427 2371

www.ee.sgs.com/korea

1.6. Test Equipment List

Equipment	Manufacturer	Model	S/N	Cal Due.
Signal Generator	R & S	SMR40	100272	Jul. 15, 2012
Spectrum Analyzer	R & S	FSV30	100955	Apr. 01, 2012
Power Sensor	R & S	NRP-Z81	101341	Sep. 29, 2012
Directional Coupler	KRYTAR	152613	127445	Aug. 31, 2012
Bluetooth Tester	TESCOM	TC-3000C	3000C000296	Aug. 22, 2012
Low Pass Filter	Mini-Circuits	NLP-1200+	V9500401023-3	Aug. 22, 2012
High Pass Filter	Wainwright	WHKX3.0/18G-6SS	4	Sep. 14, 2012
DC Power Supply	Agilent	U8002A	MY50020026	Apr. 01, 2012
Preamplifier	H.P.	8447F	2944A03909	Jul. 04, 2012
Preamplifier	R & S	SCU18	10117	Mar. 23, 2012
Preamplifier	MITEQ Inc.	JS44-18004000-35-8P	1546891	Jul. 04, 2012
Test Receiver	R & S	ESU26	100109	Feb. 21, 2012
Bilog Antenna	SCHWARZBECK MESSELEKTRONIK	VULB9163	396	Apr. 27, 2012
Horn Antenna	R & S	HF906	100326	Nov. 23, 2012
Horn Antenna	SCHWARZBECK MESSELEKTRONIK	BBHA9170	BBHA9170431	Mar. 17, 2012
Antenna Master	INNCO	MM4000	N.C.R.	N.C.R.
Turn Table	INNCO	DS 1200S	N.C.R.	N.C.R.
Anechoic Chamber	SY Corporation	L × W × H (9.6 m × 6.4 m × 6.4 m)	N.C.R.	N.C.R.

The results shown in this test report refer only to the sample(s) tested unless otherwise stated. This test report cannot be reproduced, except in full, without prior written permission of the Company.

1.7. Summary of Test Results

The EUT has been tested according to the following specifications:

APPLIED STANDARD:FCC Part15		
Section	Test Item	Result
15.205(a) 15.209 15.247(d)	Transmitter Radiated Spurious Emissions Conducted Spurious Emission	Complied
15.247(a)(1)	20 dB Bandwidth	Complied
15.247(b)(1)	Maximum Peak Output Power	Complied
15.247(a)(1)	Frequency Separation	Complied
15.247(b)(1)	Number of Hopping Frequency	Complied
15.247(a)(1)(iii)	Time of Occupancy (Dwell Time)	Complied
15.247(i) 1.1307(b)(1)	Maximum Permissible Exposure (Exposure of Humans to RF Fields)	Complied

1.8. Conclusion of worst-case and operation mode

The EUT has three type of modulation (GFSK, $\pi/4$ DQPSK and 8DPSK). Each output power as following:

Modulation Type	Output power(dB m)	Output power(mW)	Symbol rate
GFSK(2 441 MHz)	0.55	1.14	1 Mbps
$\pi/4$ DQPSK(2 441 MHz)	0.83	1.21	2 Mbps
8DPSK(2 441 MHz)	0.86	1.22	3 Mbps

Therefore all applicable requirements were tested to the two type of higher output power modulation (GFSK and 8DPSK) at Middle channel (2 441 MHz).

The field strength of spurious emission was measured in three orthogonal EUT positions (x-axis, y-axis and z-axis). Worst case is x -axis.

1.9. Test report revision

Revision	Report number	Description
0	F690501/RF-RTL005288	Initial
1	F690501/RF-RTL005288-1	Modify model name
2	F690501/RF-RTL005288-2	Add maximum permissible exposure
3	F690501/RF-RTL005288-3	Change applicant name and address

The results shown in this test report refer only to the sample(s) tested unless otherwise stated. This test report cannot be reproduced, except in full, without prior written permission of the Company.

2. Transmitter Radiated Spurious Emissions and Conducted Spurious Emission

2.1. Test Setup

2.1.1. Transmitter Radiated Spurious Emissions

The diagram below shows the test setup that is utilized to make the measurements for emission from 30 MHz to 1 GHz Emissions.

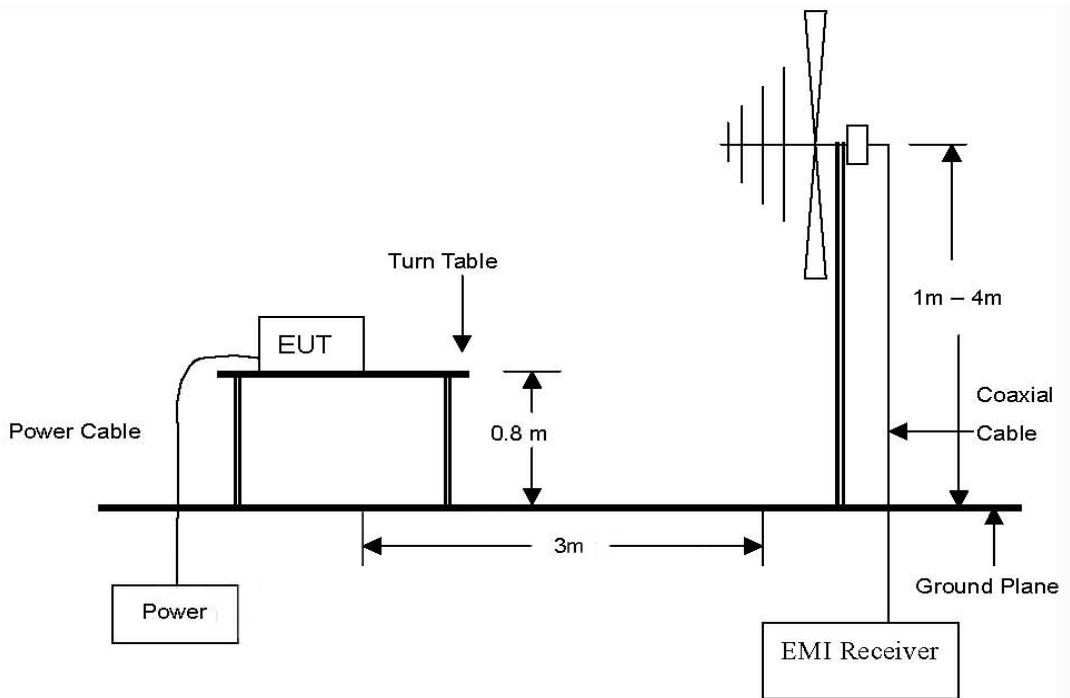

The diagram below shows the test setup that is utilized to make the measurements for emission from 1 GHz to 24.8 GHz Emissions.

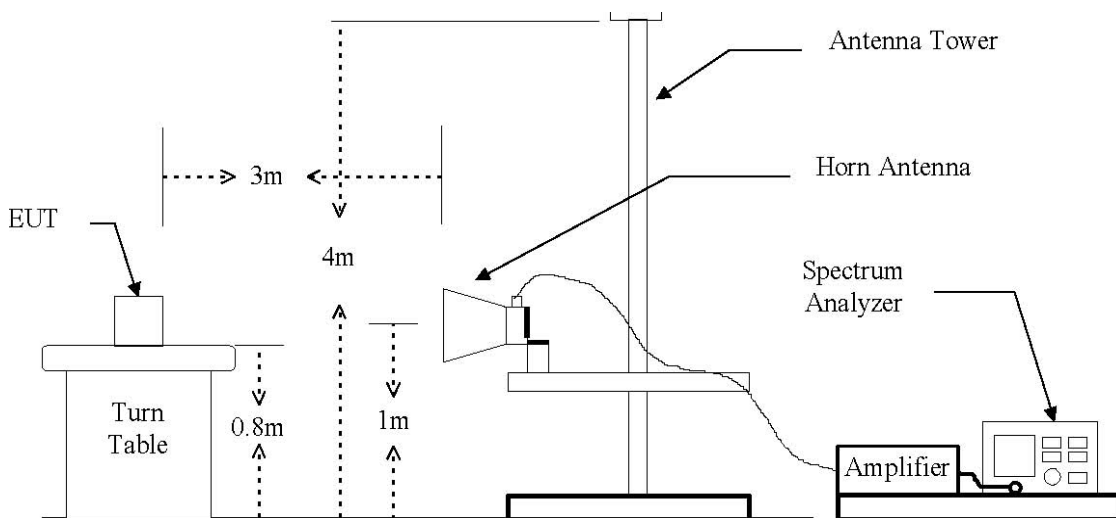

The results shown in this test report refer only to the sample(s) tested unless otherwise stated. This test report cannot be reproduced, except in full, without prior written permission of the Company.

2.1.2. Conducted Spurious Emissions

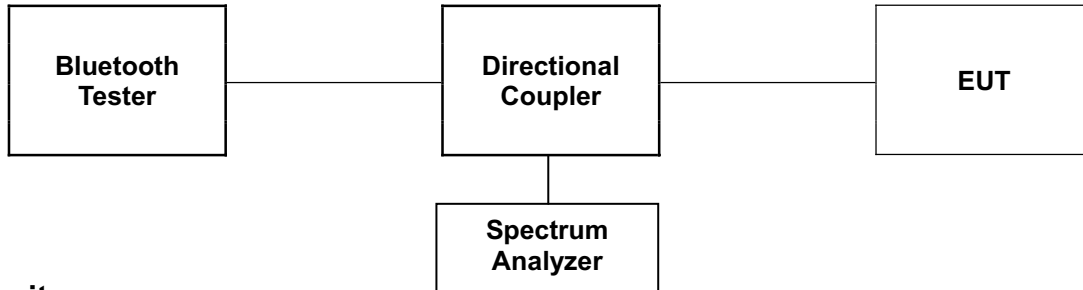

2.2. Limit

According to §15.247(d), in any 100 kHz bandwidth outside the frequency band in which the spread spectrum or digitally modulated intentional radiator is operating, the radio frequency power that is produced by the intentional radiator shall be at least 20 dB below that in the 100 kHz bandwidth within the band that contains the highest level of the desired power, based on either an RF conducted or a radiated measurement, provided the transmitter demonstrates compliance with the peak conducted power limits. If the transmitter complies with the conducted power limits based on the use of RMS averaging over a time interval, as permitted under paragraph(b)(3) of this section, the attenuation required under this paragraph shall be 30 dB instead of 20 dB. Attenuation below the general limits specified in section §15.209(a) is not required. In addition, radiated emission which in the restricted band, as define in section §15.205(a), must also comply the radiated emission limits specified in section §15.209(a) (see section §15.205(c))

According to § 15.209(a), Except as provided elsewhere in this Subpart, the emissions from an intentional radiator shall not exceed the field strength levels specified in the following table :

Frequency (MHz)	Distance (Meters)	Field Strength (dB µV/m)	Field Strength (µV/m)
30 - 88	3	40.0	100
88 – 216	3	43.5	150
216 – 960	3	46.0	200
Above 960	3	54.0	500

The results shown in this test report refer only to the sample(s) tested unless otherwise stated. This test report cannot be reproduced, except in full, without prior written permission of the Company.

2.3. Test Procedures

Radiated emissions from the EUT were measured according to the dictates of DA000705

2.3.1. Test Procedures for Radiated Spurious Emissions

1. The EUT was placed on the top of a rotating table 0.8 meters above the ground at a 3 meter anechoic chamber test site. The table was rotated 360 degrees to determine the position of the highest radiation.
2. During performing radiated emission below 1 GHz, the EUT was set 3 meters away from the interference receiving antenna, which was mounted on the top of a variable-height antenna tower. During performing radiated emission above 1 GHz, the EUT was set 3 meter away from the interference-receiving antenna.
3. The antenna is a broadband antenna, and its height is varied from one meter to four meters above the ground to determine the maximum value of the field strength. Both horizontal and vertical polarizations of the antenna are set to make the measurement.
4. For each suspected emission, the EUT was arranged to its worst case and then the antenna was tuned to heights from 1 meter to 4 meters and the table was turned from 0 degrees to 360 degrees to find the maximum reading.
5. The test-receiver system was set to Peak Detect Function and Specified Bandwidth with Maximum Hold Mode.
6. If the emission level of the EUT in peak mode was 10 dB lower than the limit specified, then testing could be stopped and the peak values of the EUT would be reported. Otherwise the emissions that did not have 10 dB margin would be re-tested one by one using peak, quasi-peak or average method as specified and then reported in a data sheet.

NOTE ;

1. The resolution bandwidth and video bandwidth of test receiver/spectrum analyzer is 120 kHz for Peak detection (PK) and Quasi-peak detection (QP) at frequency below 1 GHz.
2. The resolution bandwidth and video bandwidth of test receiver/spectrum analyzer is 1 MHz for Peak detection and frequency above 1 GHz.
3. The resolution bandwidth of test receiver/spectrum analyzer is 1 MHz and the video bandwidth is 10 Hz for Average detection (AV) at frequency above 1 GHz.
4. When Average result is different from Peak result over 20 dB (over-averaging), we find an appropriate video bandwidth as an inverse of duty cycle period and is used for Average detection (AV) at frequency above 1 GHz.

2.3.2. Test Procedures for Conducted Spurious Emissions

1. The transmitter output was connected to the spectrum analyzer.
2. The bandwidth of the fundamental frequency was measured with the spectrum analyzer using RBW=100 kHz, VBW=100 kHz.

The results shown in this test report refer only to the sample(s) tested unless otherwise stated. This test report cannot be reproduced, except in full, without prior written permission of the Company.

2.4. Test Results

Ambient temperature : (24 ± 2) °C
 Relative humidity : 47 % R.H.

2.4.1. Spurious Radiated Emission (Worst case configuration_ 8DPSK mode)

The frequency spectrum from 30 MHz to 1 000 MHz was investigated. Emission levels are not reported much lower than the limits by over 30 dB. All reading values are peak values.

Radiated Emissions			Ant	Correction Factors		Total	FCC Limit	
Frequency (MHz)	Reading (dB μ V)	Detect Mode	Pol.	AF (dB/m)	AMP + CL (dB)	Actual (dB μ V/m)	Limit (dB μ V/m)	Margin (dB)
107.72	34.4	Peak	H	10.9	-25.9	19.4	43.5	24.1
161.96	36.2	Peak	H	9.1	-25.2	20.1	43.5	23.4
216.00	42.2	Peak	H	11.5	-24.6	29.1	43.5	14.4
264.01	46.4	Peak	H	12.6	-24.3	34.7	46.0	11.3
269.99	45.7	Peak	H	12.6	-24.3	34.0	46.0	12.0
324.03	40.0	Peak	H	12.9	-24.6	28.3	46.0	17.7
396.01	43.1	Peak	H	13.7	-24.5	32.3	46.0	13.7
660.02	37.5	Peak	H	18.7	-24.2	32.0	46.0	14.0
792.02	35.6	Peak	H	20.8	-23.9	32.5	46.0	13.5
924.02	40.4	Peak	H	16.7	-22.9	34.2	46.0	11.8

Remark:

1. All spurious emission at channels are almost the same below 1 GHz, so that middle channel was chosen at representative in final test.
2. Actual = Reading + AF + AMP + CL

The results shown in this test report refer only to the sample(s) tested unless otherwise stated. This test report cannot be reproduced, except in full, without prior written permission of the Company.

2.4.2. Spurious Radiated Emission

The frequency spectrum above 1 000 MHz was investigated. Emission levels are not reported much lower than the limits by over 30 dB.

Operating Mode: GFSK

A. Low Channel (2 402 MHz)

Radiated Emissions			Ant	Correction Factors		Total	FCC Limit	
Frequency (MHz)	Reading (dB μ V)	Detect Mode	Pol.	AF (dB/m)	CL (dB)	Actual (dB μ V/m)	Limit (dB μ V/m)	Margin (dB)
*2 390.00	27.46	Peak	V	28.05	5.23	60.74	74.00	13.26
*2 390.00	15.72	Average	V	28.05	5.23	49.00	54.00	5.00

Radiated Emissions			Ant	Correction Factors		Total	FCC Limit	
Frequency (MHz)	Reading (dB μ V)	Detect Mode	Pol.	AF (dB/m)	AMP+CL (dB)	Actual (dB μ V/m)	Limit (dB μ V/m)	Margin (dB)
4 805.59	45.68	Peak	V	32.28	-26.13	51.83	74.00	22.17
4 805.59	32.23	Average	V	32.28	-26.13	38.38	54.00	15.62
Above 4 900.00	Not detected	-	-	-	-	-	-	-

B. Middle Channel (2 441 MHz)

Radiated Emissions			Ant	Correction Factors		Total	FCC Limit	
Frequency (MHz)	Reading (dB μ V)	Detect Mode	Pol.	AF (dB/m)	AMP+CL (dB)	Actual (dB μ V/m)	Limit (dB μ V/m)	Margin (dB)
4 881.85	45.97	Peak	V	32.85	-26.18	52.64	74.00	21.36
4 881.85	32.89	Average	V	32.85	-26.18	39.56	54.00	14.44
Above 4 900.00	Not detected	-	-	-	-	-	-	-

The results shown in this test report refer only to the sample(s) tested unless otherwise stated. This test report cannot be reproduced, except in full, without prior written permission of the Company.

C. High Channel (2 480 MHz)

Radiated Emissions			Ant	Correction Factors		Total	FCC Limit	
Frequency (MHz)	Reading (dB μ V)	Detect Mode	Pol.	AF (dB/m)	CL (dB)	Actual (dB μ V/m)	Limit (dB μ V/m)	Margin (dB)
*2 483.50	26.81	Peak	V	28.31	5.37	60.49	74.00	13.51
*2 483.50	15.61	Average	V	28.31	5.37	49.29	54.00	4.71

Radiated Emissions			Ant	Correction Factors		Total	FCC Limit	
Frequency (MHz)	Reading (dB μ V)	Detect Mode	Pol.	AF (dB/m)	AMP+CL (dB)	Actual (dB μ V/m)	Limit (dB μ V/m)	Margin (dB)
4 959.17	4959.17	Peak	V	33.31	-25.87	52.82	74.00	21.18
4 959.17	4959.17	Average	V	33.31	-25.87	39.46	54.00	14.54
Above 5 000.00	Not detected	-	-	-	-	-	-	-

The results shown in this test report refer only to the sample(s) tested unless otherwise stated. This test report cannot be reproduced, except in full, without prior written permission of the Company.

Operating Mode: 8DPSK

A. Low Channel (2 402 MHz)

Radiated Emissions			Ant	Correction Factors		Total	FCC Limit	
Frequency (MHz)	Reading (dB μ V)	Detect Mode	Pol.	AF (dB/m)	CL (dB)	Actual (dB μ V/m)	Limit (dB μ V/m)	Margin (dB)
*2 390.00	27.14	Peak	V	28.05	5.23	60.42	74.00	13.58
*2 390.00	15.68	Average	V	28.05	5.23	48.96	54.00	5.04

Radiated Emissions			Ant	Correction Factors		Total	FCC Limit	
Frequency (MHz)	Reading (dB μ V)	Detect Mode	Pol.	AF (dB/m)	AMP+CL (dB)	Actual (dB μ V/m)	Limit (dB μ V/m)	Margin (dB)
4 801.70	45.37	Peak	V	32.29	-26.10	51.56	74.00	22.44
4 801.70	31.67	Average	V	32.29	-26.10	37.86	54.00	16.14
Above 4 900.00	Not detected	-	-	-	-	-	-	-

B. Middle Channel (2 441 MHz)

Radiated Emissions			Ant	Correction Factors		Total	FCC Limit	
Frequency (MHz)	Reading (dB μ V)	Detect Mode	Pol.	AF (dB/m)	AMP+CL (dB)	Actual (dB μ V/m)	Limit (dB μ V/m)	Margin (dB)
4 882.12	44.67	Peak	V	32.85	-26.18	51.34	74.00	22.66
4 882.12	31.41	Average	V	32.85	-26.18	38.08	54.00	15.92
Above 4 900.00	Not detected	-	-	-	-	-	-	-

The results shown in this test report refer only to the sample(s) tested unless otherwise stated. This test report cannot be reproduced, except in full, without prior written permission of the Company.

C. High Channel (2 480 MHz)

Radiated Emissions			Ant	Correction Factors		Total	FCC Limit	
Frequency (MHz)	Reading (dB μ V)	Detect Mode	Pol.	AF (dB/m)	CL (dB)	Actual (dB μ V/m)	Limit (dB μ V/m)	Margin (dB)
*2 483.50	27.10	Peak	V	28.31	5.37	60.78	74.00	13.22
*2 483.50	15.67	Average	V	28.31	5.37	49.35	54.00	4.65

Radiated Emissions			Ant	Correction Factors		Total	FCC Limit	
Frequency (MHz)	Reading (dB μ V)	Detect Mode	Pol.	AF (dB/m)	AMP+CL (dB)	Actual (dB μ V/m)	Limit (dB μ V/m)	Margin (dB)
4 957.95	44.87	Peak	V	33.30	-25.86	52.31	74.00	21.69
4 957.95	31.10	Average	V	33.30	-25.86	38.54	54.00	15.46
Above 5 000.00	Not detected	-	-	-	-	-	-	-

Remarks ;

1. "*" means the restricted band.
2. Measuring frequencies from 1 GHz to the 10th harmonic of highest fundamental Frequency.
3. Radiated emissions measured in frequency above 1 000 MHz were made with an instrument using peak/average detector mode.
4. Average test would be performed if the peak result were greater than the average limit.
5. Actual = Reading + AF + AMP + CL

The results shown in this test report refer only to the sample(s) tested unless otherwise stated. This test report cannot be reproduced, except in full, without prior written permission of the Company.

2.4.3. Spurious RF Conducted Emissions: Plot of Spurious RF Conducted Emission Operating Mode: GFSK

Low Channel

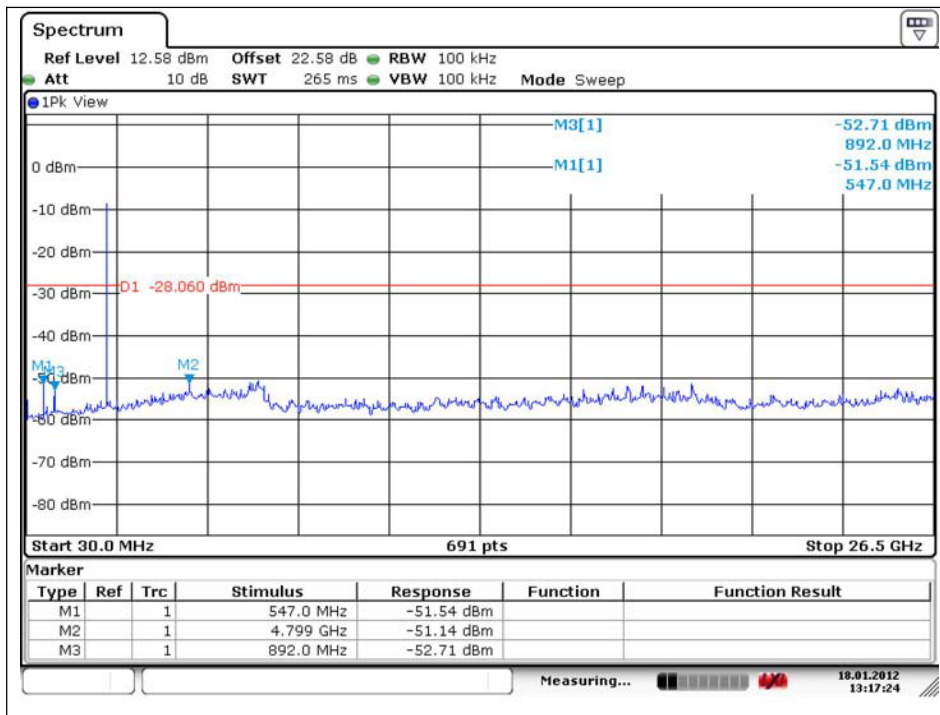
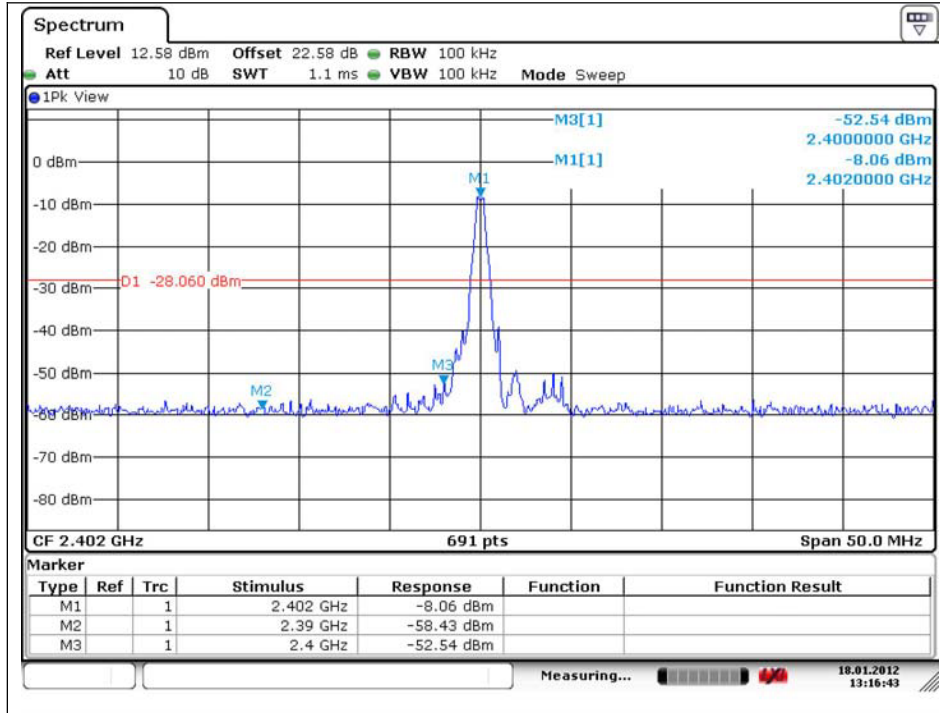

The results shown in this test report refer only to the sample(s) tested unless otherwise stated. This test report cannot be reproduced, except in full, without prior written permission of the Company.

Middle Channel

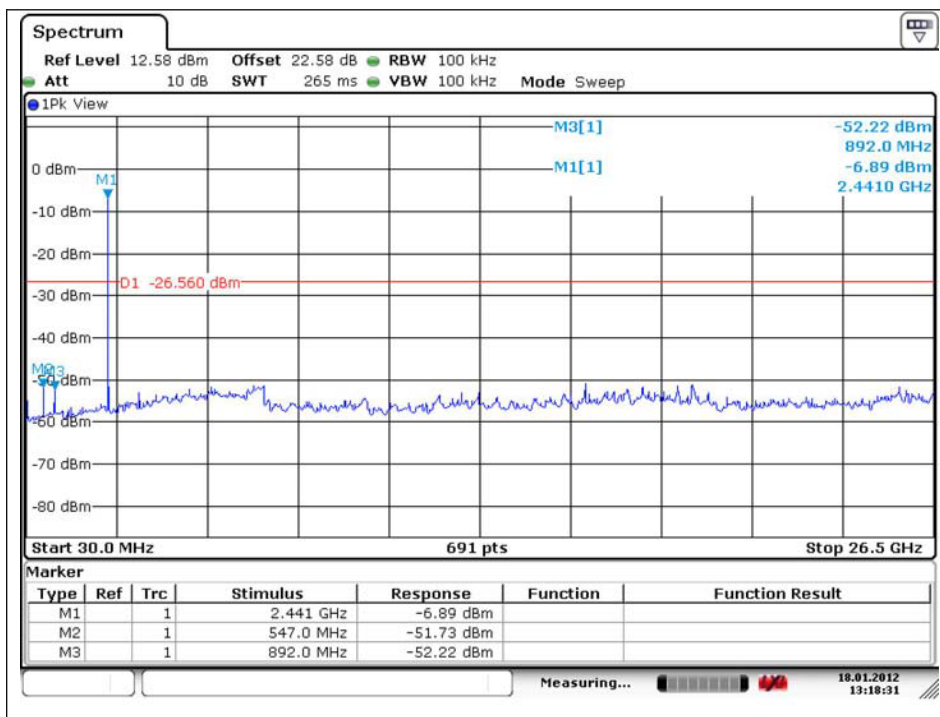
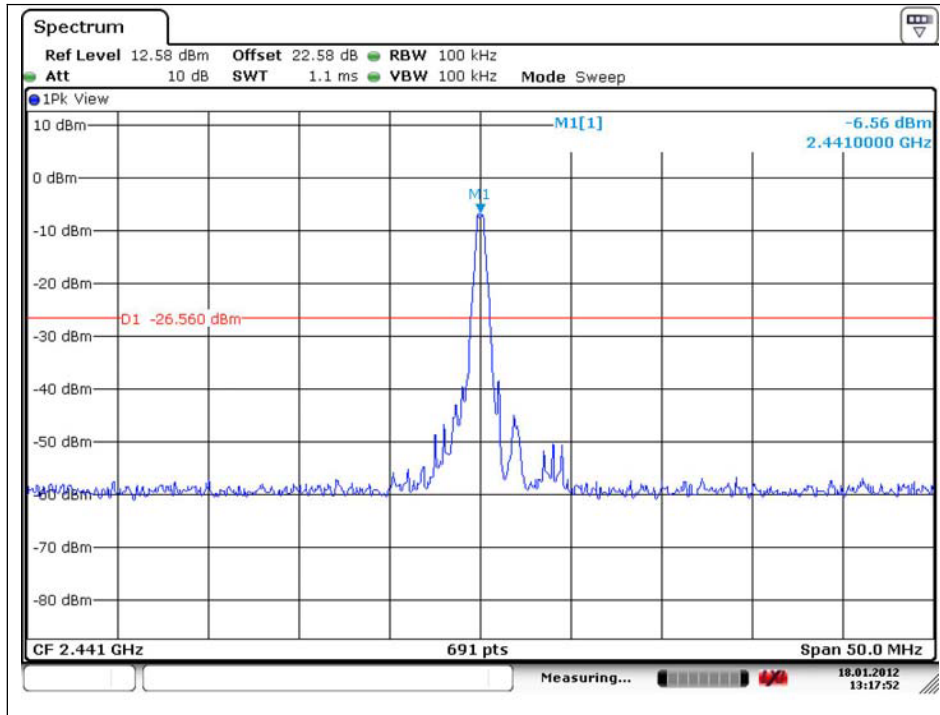

The results shown in this test report refer only to the sample(s) tested unless otherwise stated. This test report cannot be reproduced, except in full, without prior written permission of the Company.

High Channel

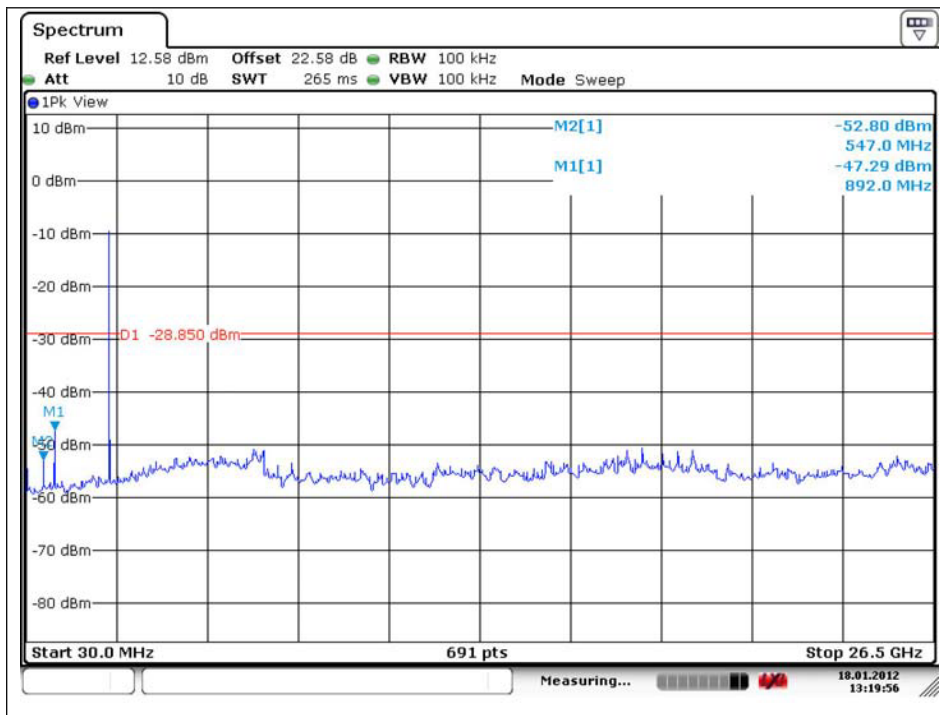
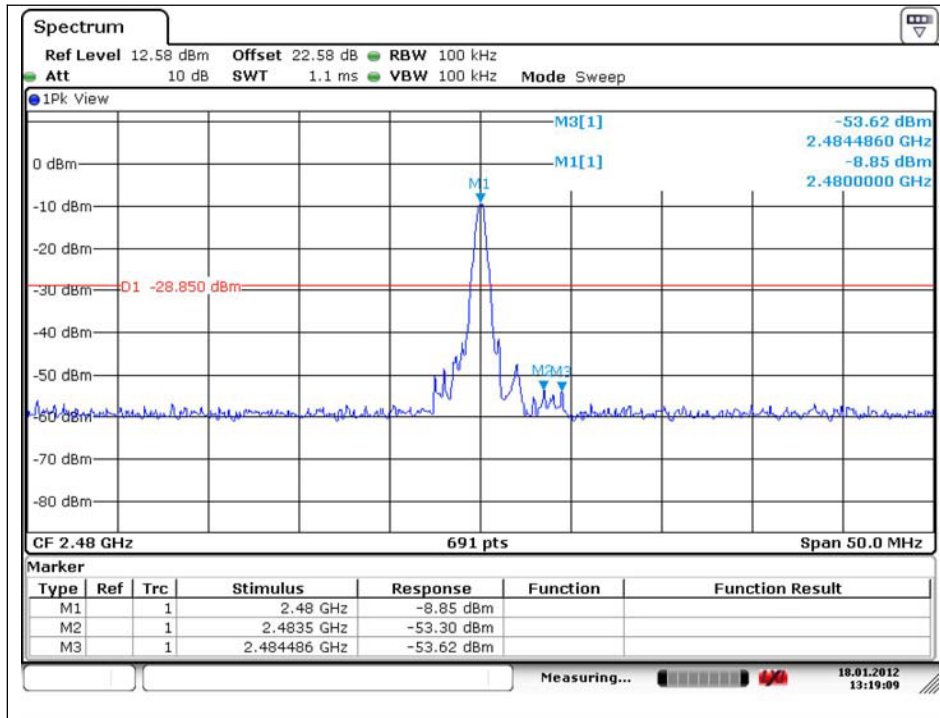

The results shown in this test report refer only to the sample(s) tested unless otherwise stated. This test report cannot be reproduced, except in full, without prior written permission of the Company.

Bandedge at Hopping

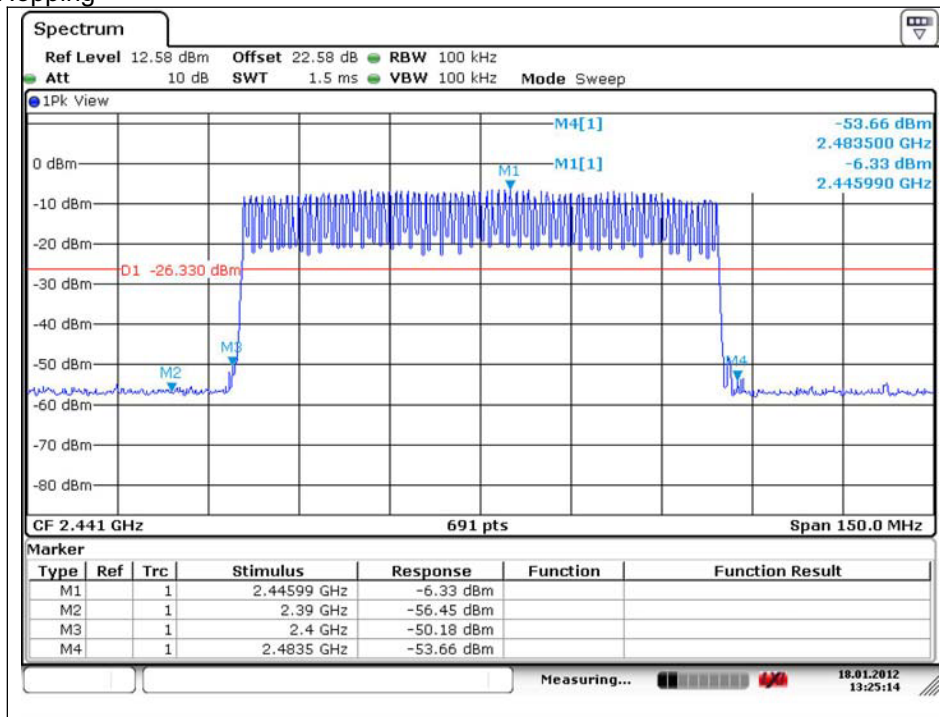

The results shown in this test report refer only to the sample(s) tested unless otherwise stated. This test report cannot be reproduced, except in full, without prior written permission of the Company.

Operating Mode : 8DPSK
Low Channel

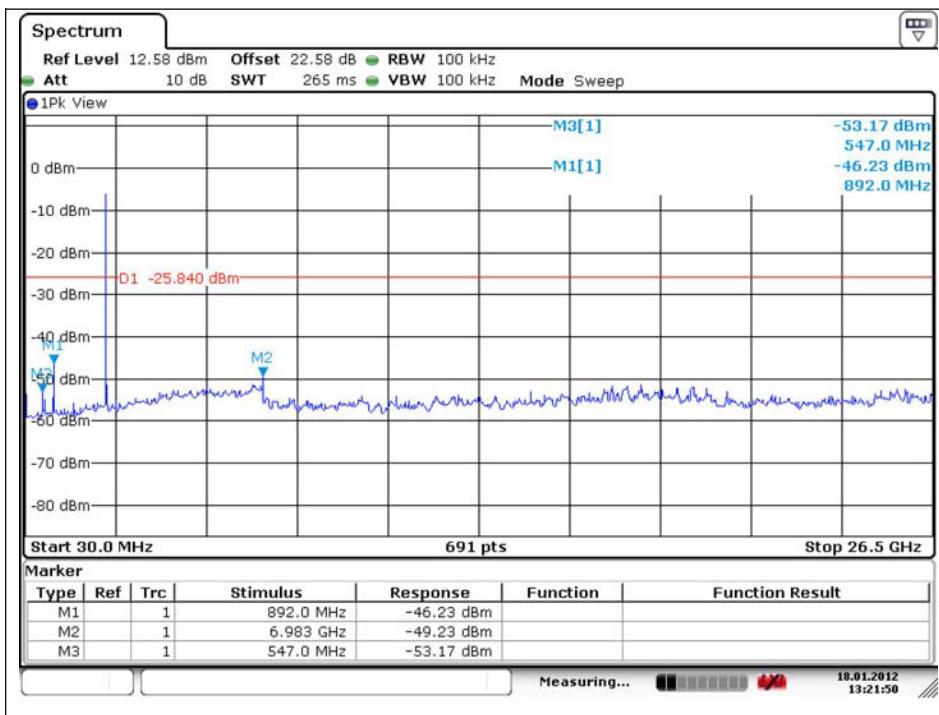
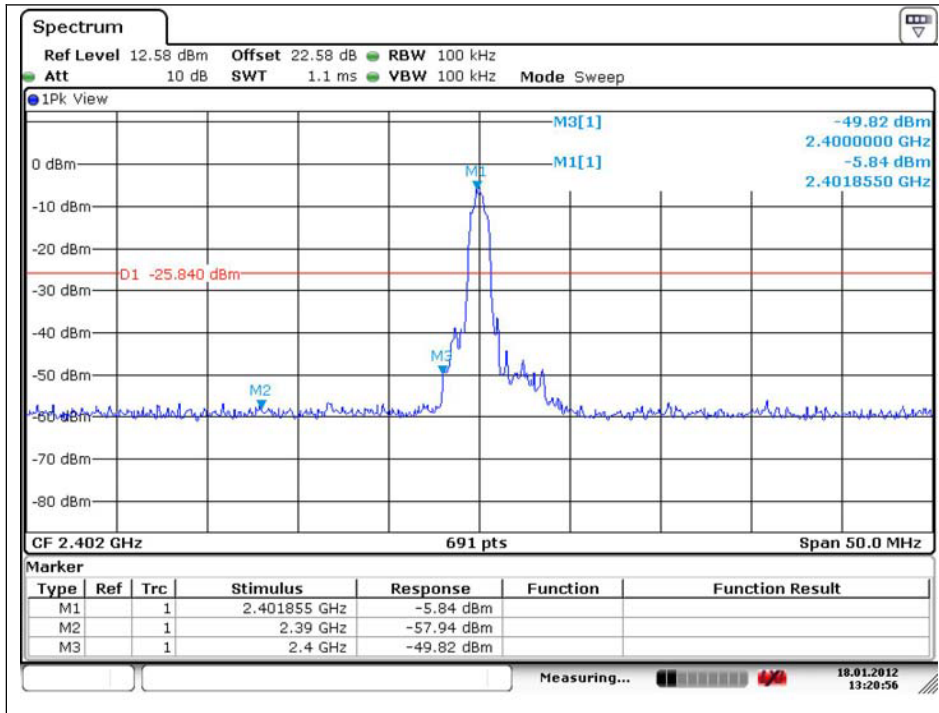

The results shown in this test report refer only to the sample(s) tested unless otherwise stated. This test report cannot be reproduced, except in full, without prior written permission of the Company.

Middle Channel

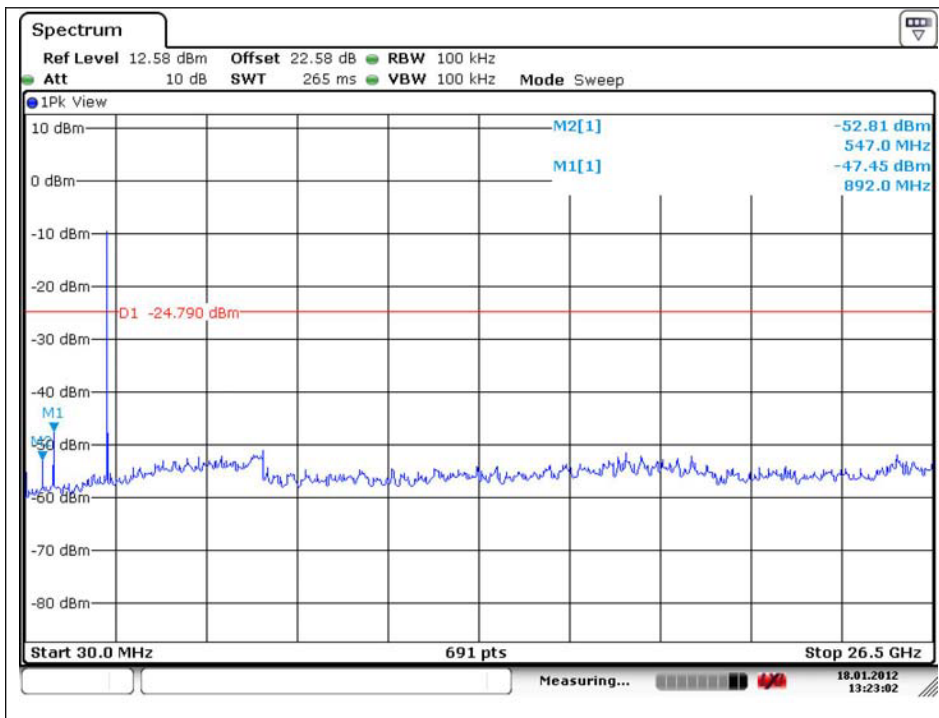
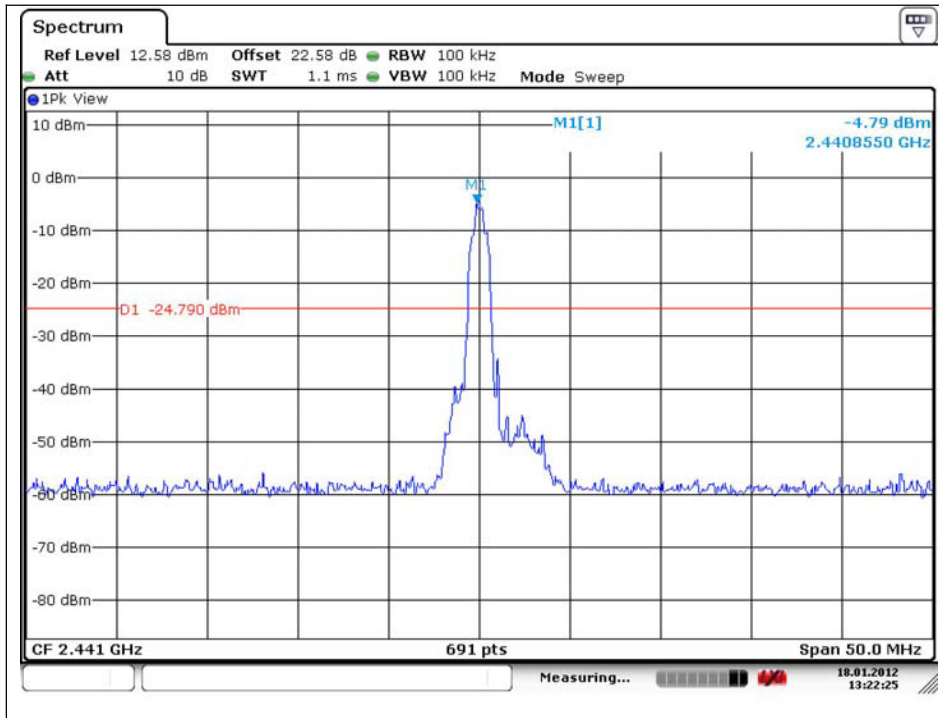

The results shown in this test report refer only to the sample(s) tested unless otherwise stated. This test report cannot be reproduced, except in full, without prior written permission of the Company.

High Channel

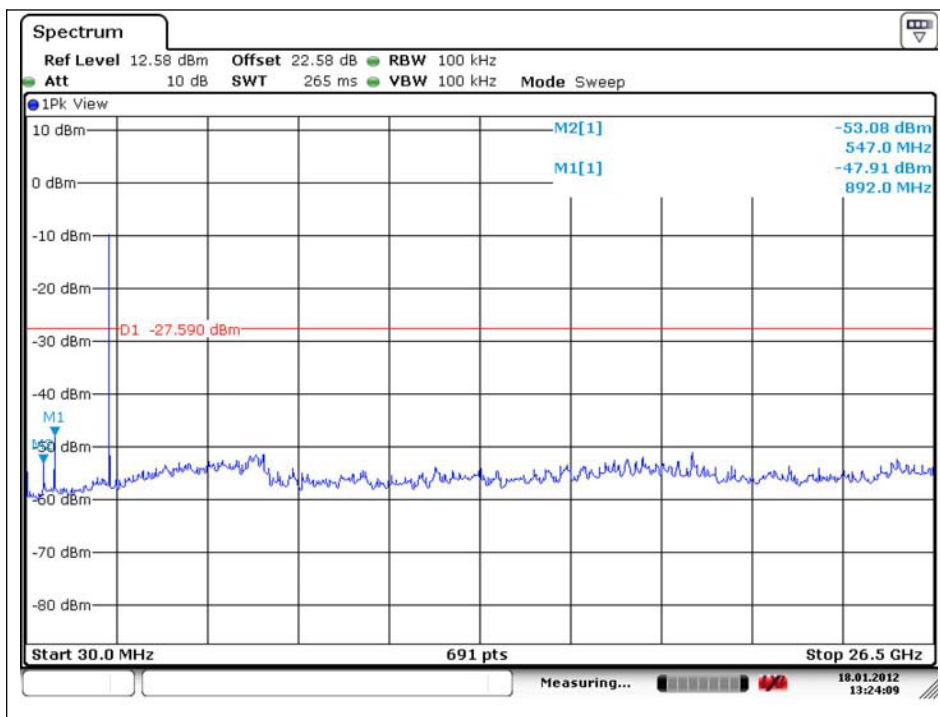
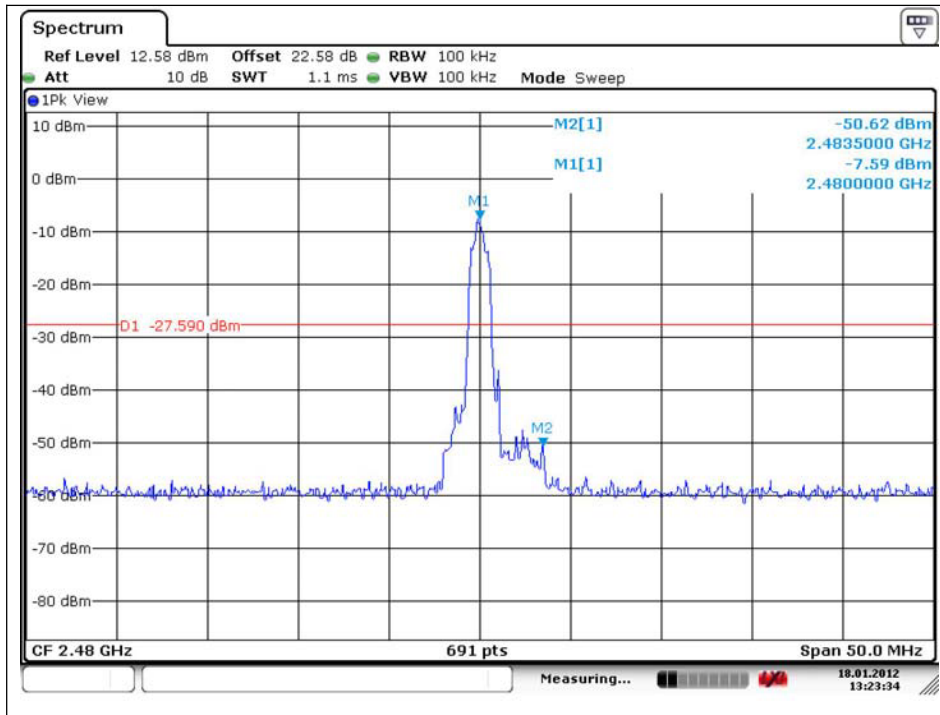

The results shown in this test report refer only to the sample(s) tested unless otherwise stated. This test report cannot be reproduced, except in full, without prior written permission of the Company.

Bandedge at Hopping

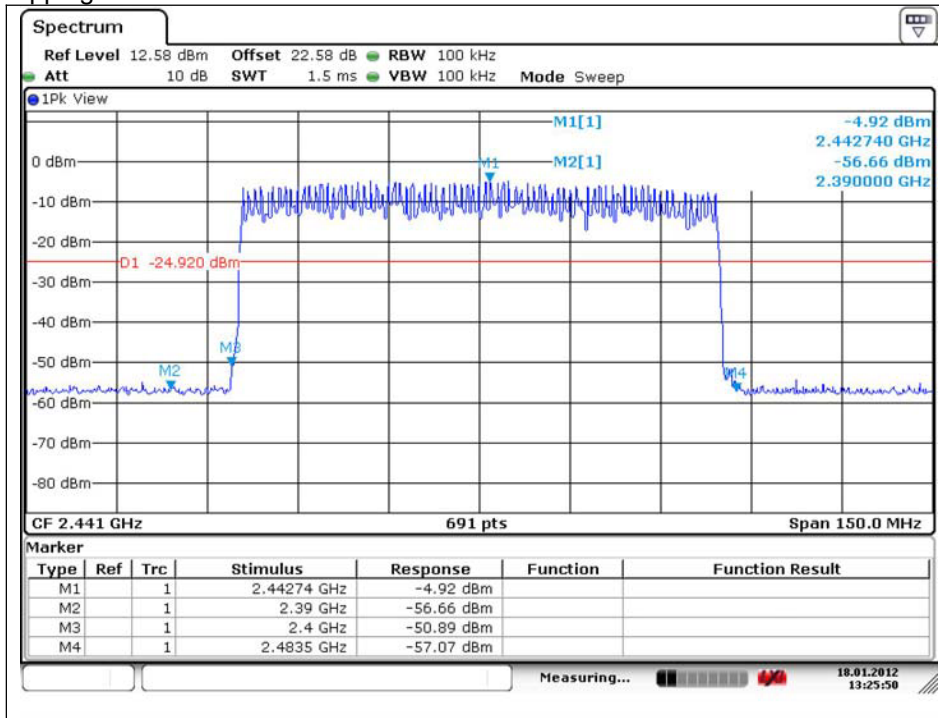

The results shown in this test report refer only to the sample(s) tested unless otherwise stated. This test report cannot be reproduced, except in full, without prior written permission of the Company.

3. 20 dB Bandwidth Measurement

3.1. Test Setup

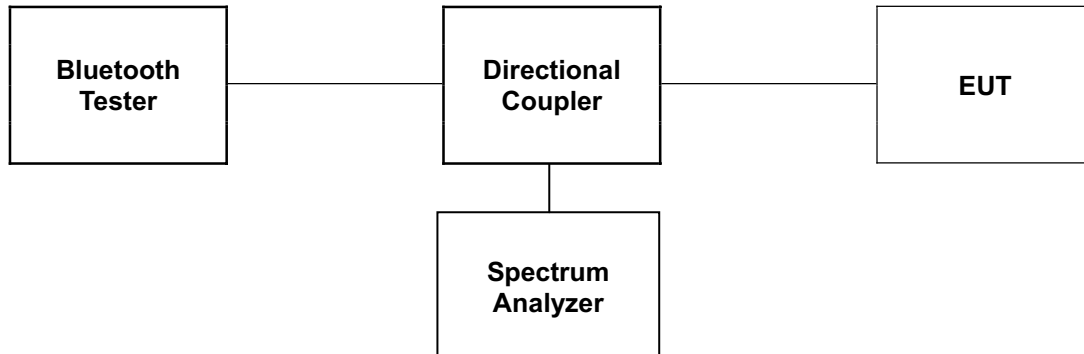

3.2. Limit

Limit: Not Applicable

3.3. Test Procedure

1. The 20 dB band width was measured with a spectrum analyzer connected to RF antenna connector(conducted measurement) while EUT was operating in transmit mode at the appropriate center frequency. The analyzer center frequency was set to the EUT carrier frequency, using the analyzer. Display Line and Marker Delta functions, the 20 dB band width of the emission was determined.
2. The bandwidth of the fundamental frequency was measured with the spectrum analyzer using RBW = 100 kHz, VBW = 100 kHz, Span = 5 MHz.

The results shown in this test report refer only to the sample(s) tested unless otherwise stated. This test report cannot be reproduced, except in full, without prior written permission of the Company.

3.4. Test Results

Ambient temperature : (24 ± 2) °C
 Relative humidity : 47 % R.H.

Operation Mode	Channel	Channel Frequency (MHz)	20 dB Bandwidth (MHz)
GFSK	Low	2 402	1.114
	Middle	2 441	1.122
	High	2 480	1.114
8DPSK	Low	2 402	1.346
	Middle	2 441	1.339
	High	2 480	1.346

The results shown in this test report refer only to the sample(s) tested unless otherwise stated. This test report cannot be reproduced, except in full, without prior written permission of the Company.

20 dB Bandwidth

Operating Mode: GFSK

Low Channel

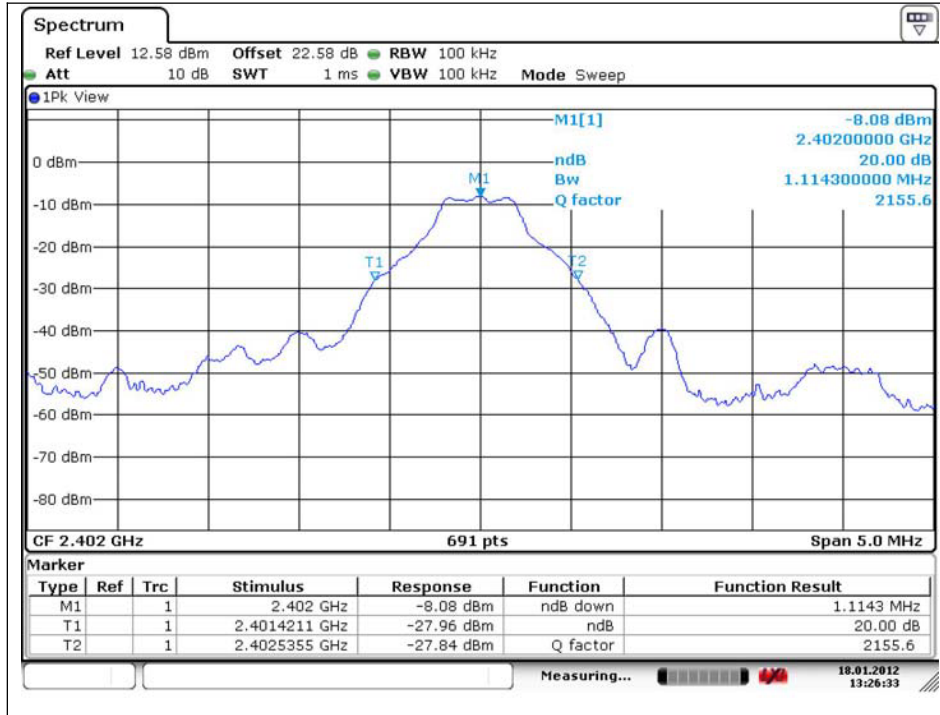

Middle Channel

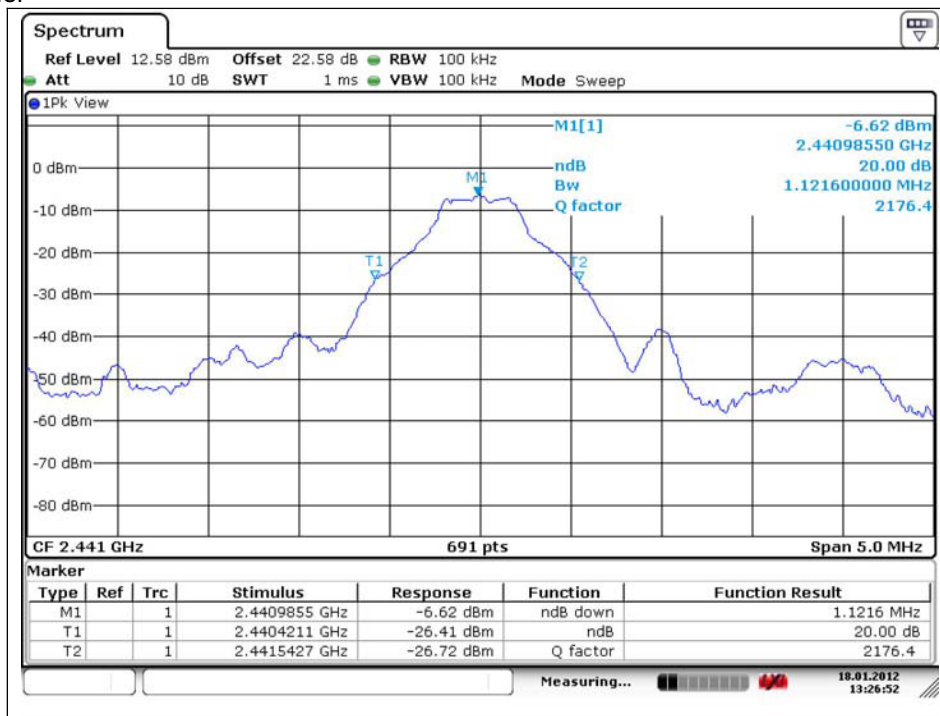

The results shown in this test report refer only to the sample(s) tested unless otherwise stated. This test report cannot be reproduced, except in full, without prior written permission of the Company.

High Channel

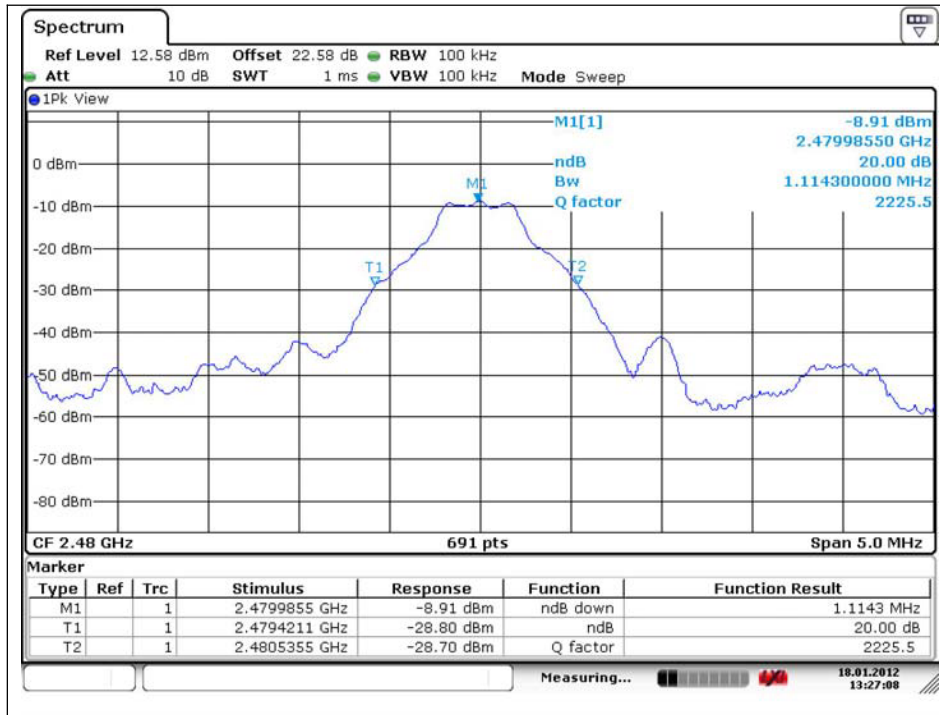

Operating Mode: 8DPSK

Low Channel

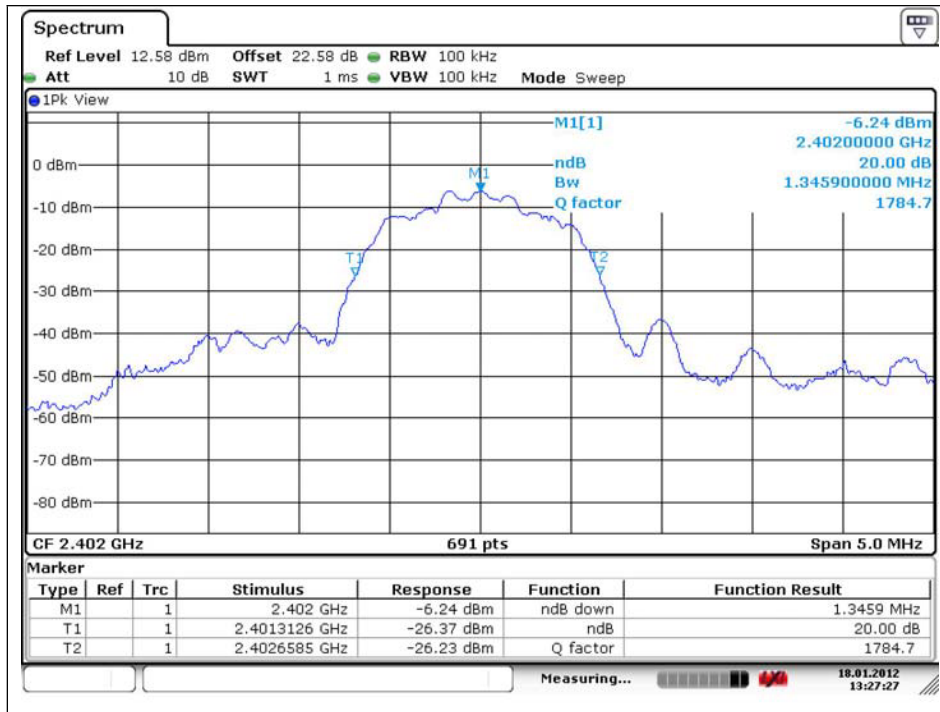

The results shown in this test report refer only to the sample(s) tested unless otherwise stated. This test report cannot be reproduced, except in full, without prior written permission of the Company.

Middle Channel

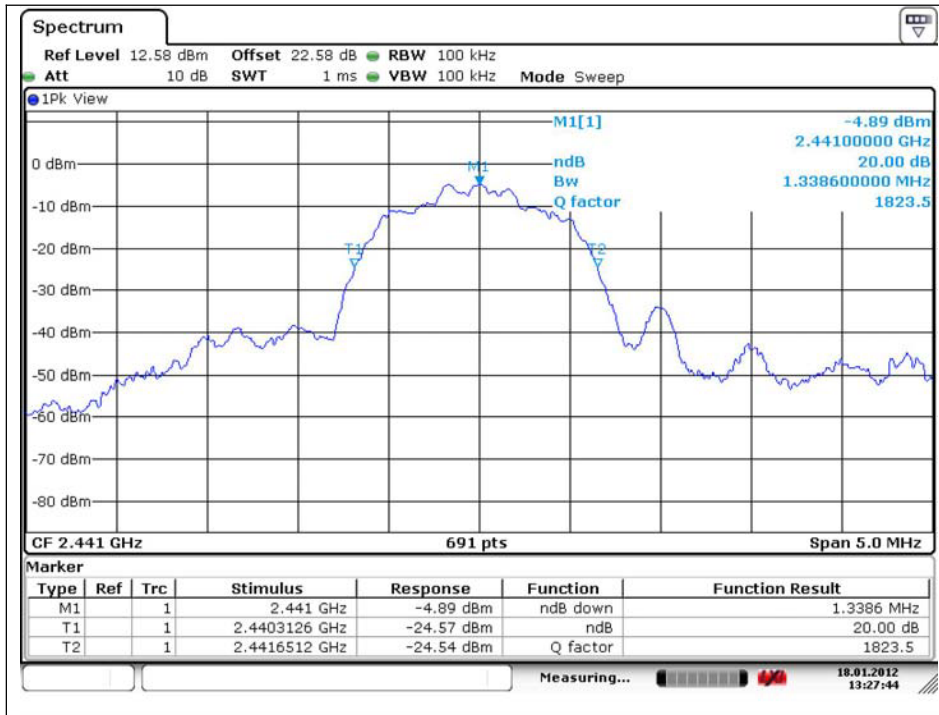

High Channel

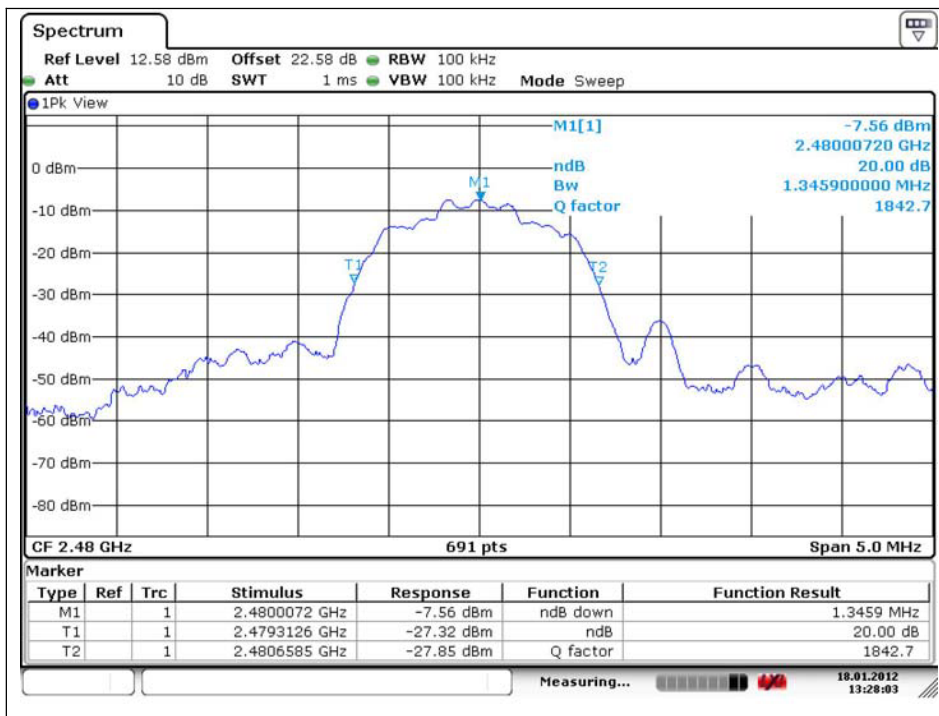

The results shown in this test report refer only to the sample(s) tested unless otherwise stated. This test report cannot be reproduced, except in full, without prior written permission of the Company.

4. Maximum Peak Output Power Measurement

4.1. Test Setup

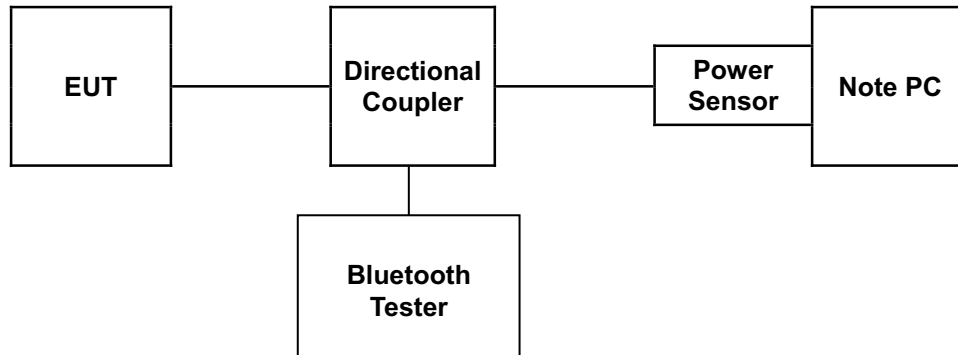

4.2. Limit

The maximum peak output power of the intentional radiator shall not exceed the following :

1. §15.247(a)(1), Frequency hopping systems shall have hopping channel carrier frequencies separated by a minimum of 25 kHz or the 20 dB bandwidth of the hopping channel, whichever is greater, provided the systems operate with an output power no greater than 125 mW.
2. §15.247(b)(1), For frequency hopping systems operating in the 2 400 – 2 483.5 MHz employing at least 75 non-overlapping hopping channels, and all frequency hopping systems in the 5 725 – 5 805 MHz band: 1 Watt.

4.3. Test Procedure

1. Place the EUT on the table and set it in the transmitting mode.
2. Remove the antenna from the EUT and then connect a low loss RF cable from the antenna port to the Power sensor.

The results shown in this test report refer only to the sample(s) tested unless otherwise stated. This test report cannot be reproduced, except in full, without prior written permission of the Company.

4.4. Test Results

Ambient temperature : (24 ± 2) °C
 Relative humidity : 47 % R.H.

Operation Mode	Channel	Channel Frequency (MHz)	Attenuator + Cable offset (dB)	Peak Power Result (dB m)	Peak Power Limit (dB m)
GFSK	Low	2 402	21.55	0.30	30.00
	Middle	2 441	21.76	0.55	30.00
	High	2 480	21.83	0.16	30.00
8DPSK	Low	2 402	21.55	0.56	20.97
	Middle	2 441	21.76	0.86	20.97
	High	2 480	21.83	0.30	20.97

The results shown in this test report refer only to the sample(s) tested unless otherwise stated. This test report cannot be reproduced, except in full, without prior written permission of the Company.

5. Hopping Channel Separation

5.1. Test Setup

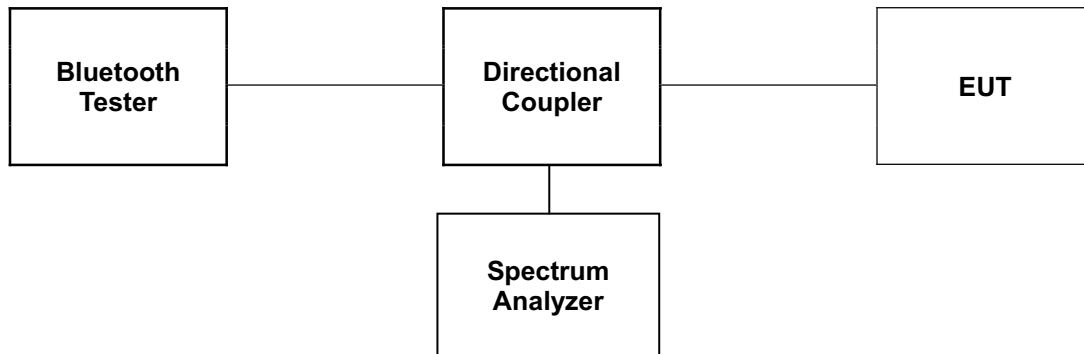

5.2. Limit

§15.247(a)(1) Frequency hopping system operating in 2 400 – 2 483.5 MHz. Band may have hopping channel carrier frequencies that are separated by 25 kHz or two-third of 20 dB bandwidth of the hopping channel, whichever is greater, provided the systems operate with an output power no greater than 125 mW.

5.3. Test Procedure

1. Check the calibration of the measuring instrument using either an internal calibrator or a known signal from an external generator.
2. Position the EUT as shown in test setup without connection to measurement instrument. Turn on the EUT and connect it to measurement instrument. Then set it to any one convenient frequency within its operating range.
3. By using the MaxHold function record the separation of adjacent channels.
4. Measure the frequency difference of these two adjacent channels by spectrum analyzer MARK function. And then plot the result on spectrum analyzer screen.
5. Repeat above procedures until all frequencies measured were complete.
6. Set center frequency of spectrum analyzer = middle of hopping channel.
7. Set the spectrum analyzer as RBW = 100 kHz, VBW = 100 kHz, Span = 5 MHz and Sweep = sweep.

The results shown in this test report refer only to the sample(s) tested unless otherwise stated. This test report cannot be reproduced, except in full, without prior written permission of the Company.

5.4. Test Results

Ambient temperature : (24 ± 2) °C
 Relative humidity : 47 % R.H.

Operation Mode	Channel (Middle)	Adjacent Hopping Channel Separation (kHz)	Two-third of 20 dB Bandwidth (kHz)	Minimum Bandwidth (kHz)
GFSK	2 441 MHz	1 000	748.000	25
8DPSK	2 441 MHz	1 000	892.667	25

Note ;

20 dB bandwidth measurement, the measured channel separation should be greater than two-third of 20 dB bandwidth or Minimum bandwidth.

The results shown in this test report refer only to the sample(s) tested unless otherwise stated. This test report cannot be reproduced, except in full, without prior written permission of the Company.

Operating Mode: GFSK

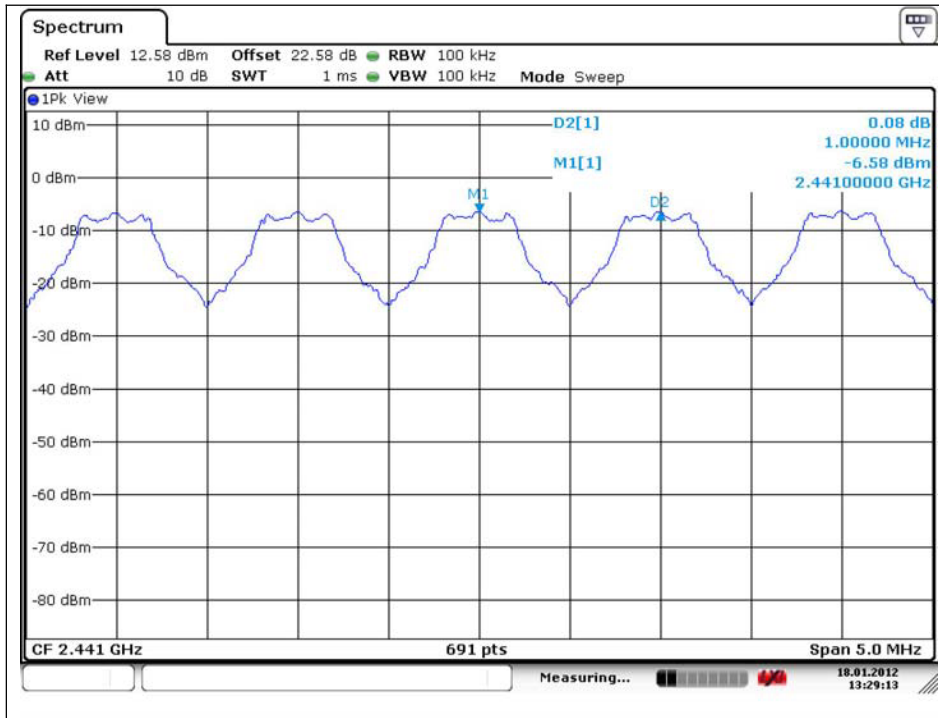

Operating Mode: 8DPSK

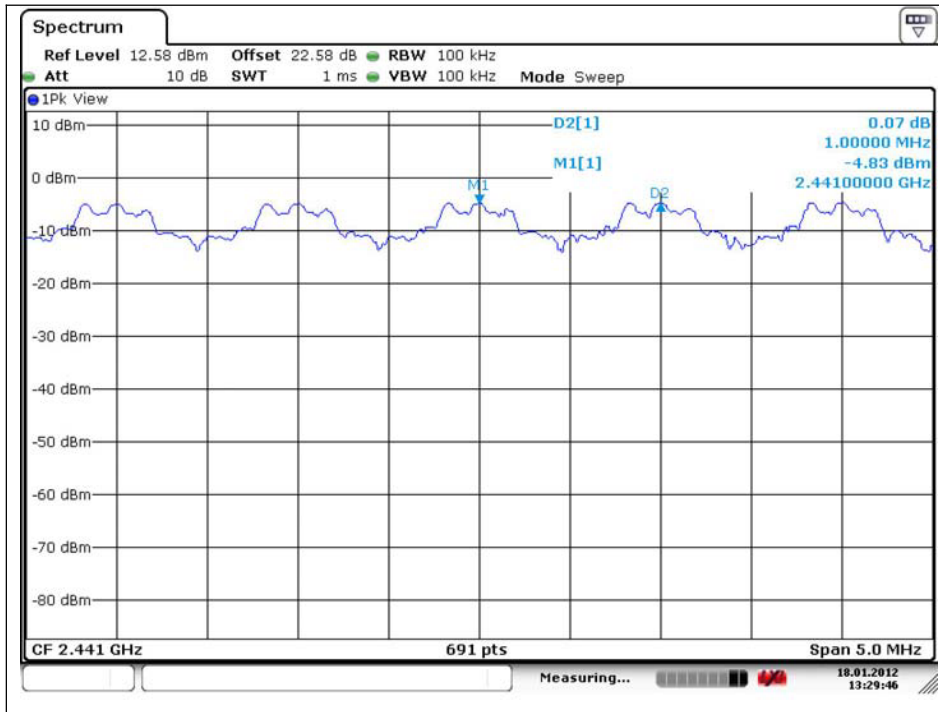

The results shown in this test report refer only to the sample(s) tested unless otherwise stated. This test report cannot be reproduced, except in full, without prior written permission of the Company.

6. Number of Hopping Frequency

6.1. Test Setup

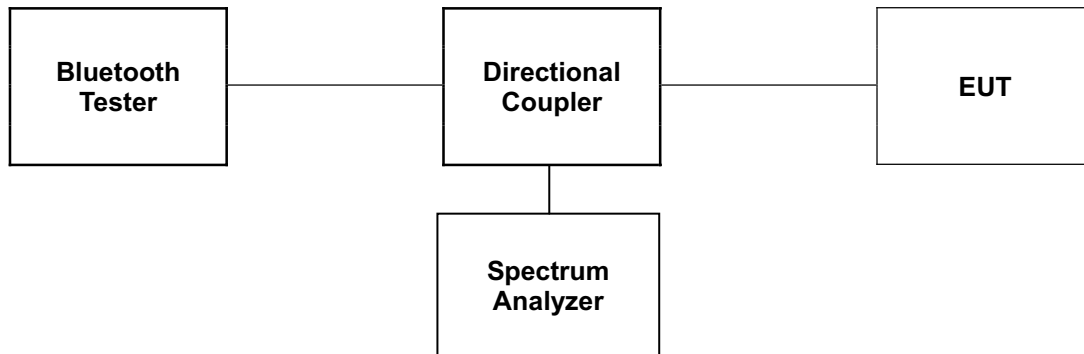

6.2. Limit

§15.247(b)(1), For frequency hopping systems operating in the 2 400 – 2 483.5 MHz employing at least 75 non-overlapping hopping channels, and all frequency hopping systems in the 5 725 – 5 805 MHz band: 1 Watt.

6.3. Test Procedure

1. Place the EUT on the table and set it in transmitting mode.
2. Remove the antenna from the EUT and then connect a low loss RF cable from the antenna the port to the Spectrum analyzer
3. Set spectrum analyzer Start = 2 400 MHz, Stop = 2 441.5 MHz, Sweep=auto and Start = 2 441.5 MHz, Stop = 2 483.5 MHz, Sweep = sweep.
4. Set the spectrum analyzer as RBW, VBW = 300 kHz.
5. Max hold, view and count how many channel in the band.

The results shown in this test report refer only to the sample(s) tested unless otherwise stated. This test report cannot be reproduced, except in full, without prior written permission of the Company.

6.4. Test Results

Ambient temperature : (24 ± 2) °C
 Relative humidity : 47 % R.H.

Operation Mode	Number of Hopping Frequency	Limit
GFSK	79	≥ 75
8DPSK	79	≥ 75

The results shown in this test report refer only to the sample(s) tested unless otherwise stated. This test report cannot be reproduced, except in full, without prior written permission of the Company.

Operating Mode: GFSK

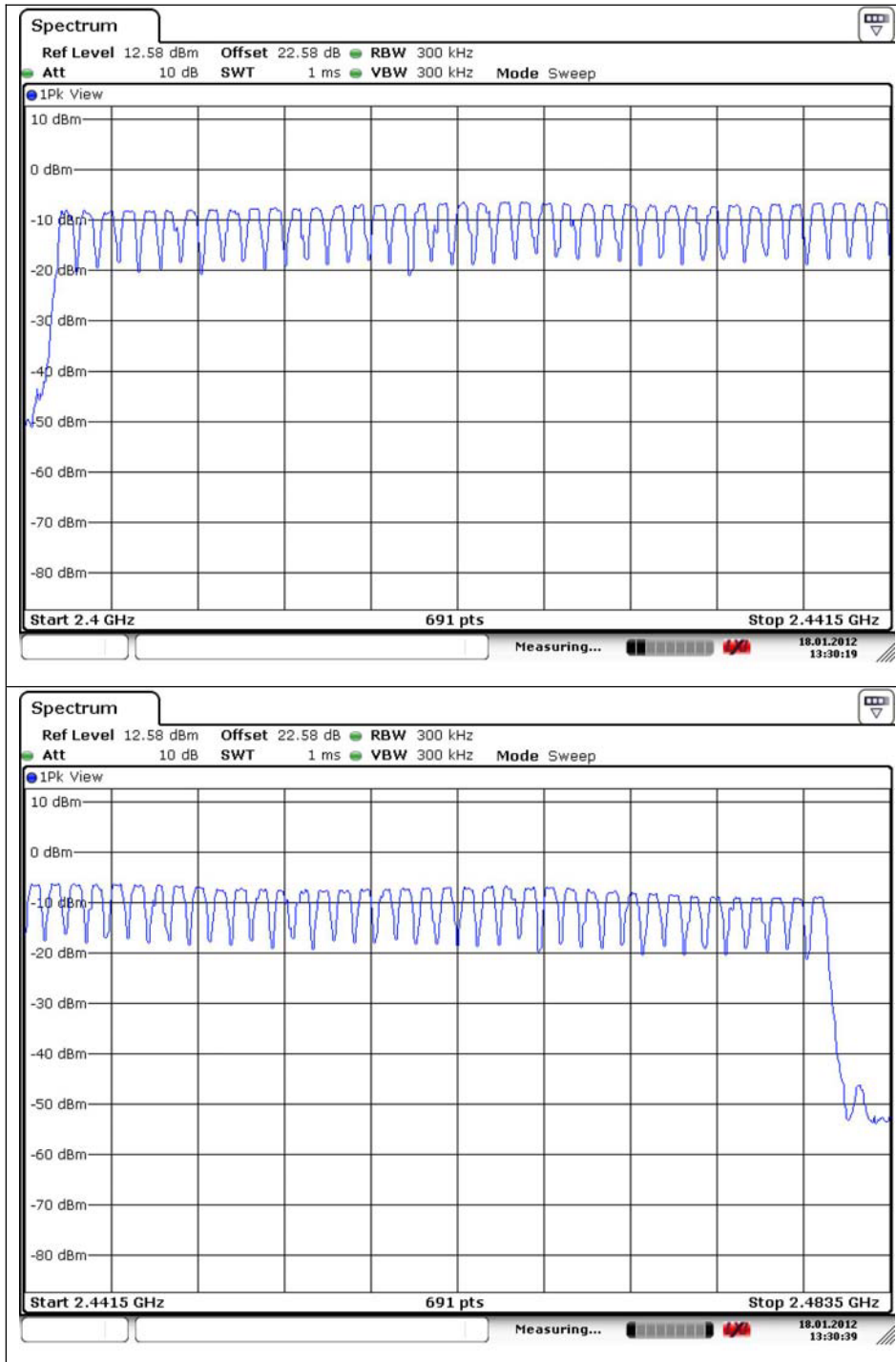

The results shown in this test report refer only to the sample(s) tested unless otherwise stated. This test report cannot be reproduced, except in full, without prior written permission of the Company.

Operating Mode : 8DPSK

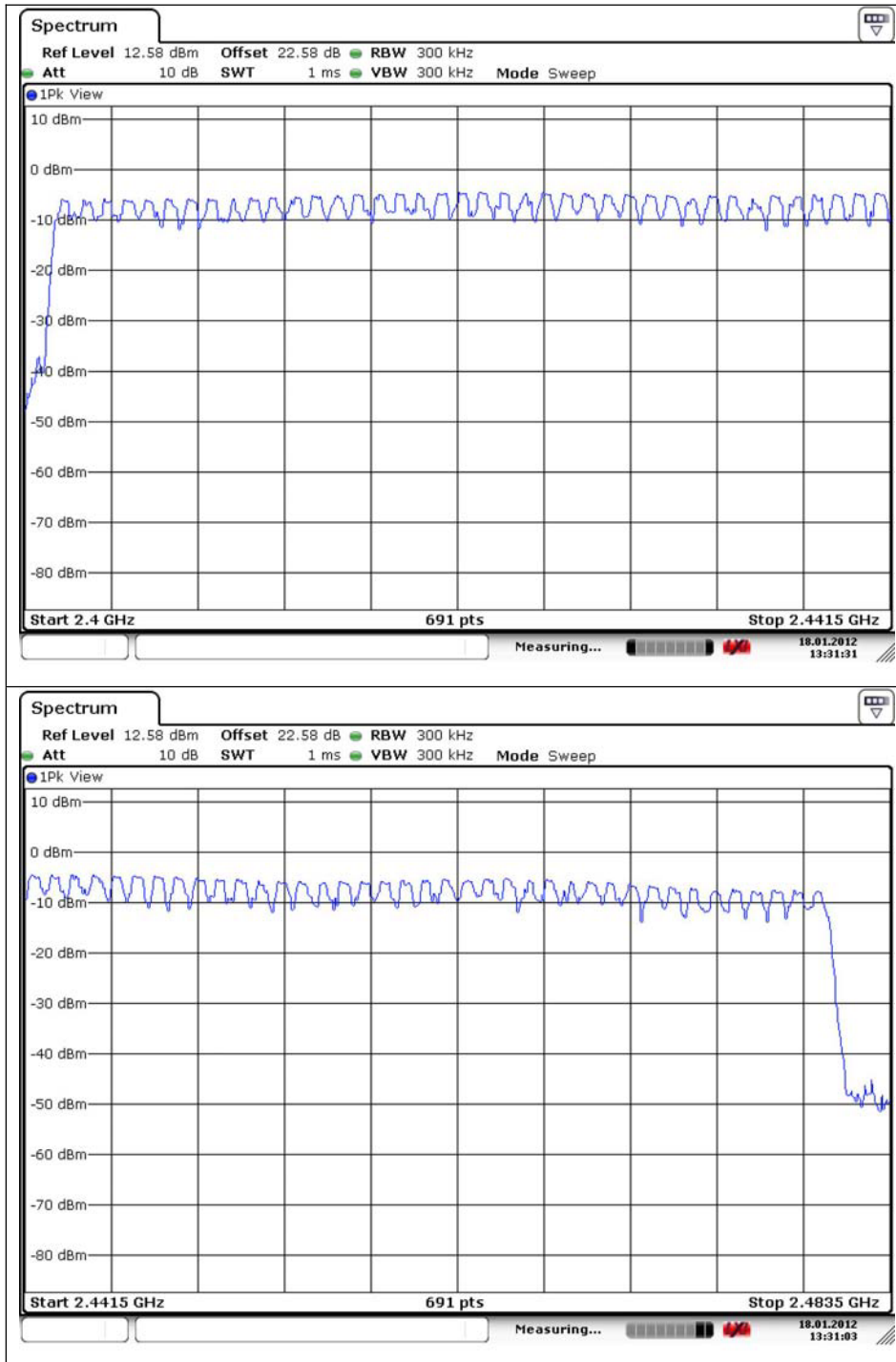

The results shown in this test report refer only to the sample(s) tested unless otherwise stated. This test report cannot be reproduced, except in full, without prior written permission of the Company.

7. Time Of Occupancy (Dwell Time)

7.1. Test Set up

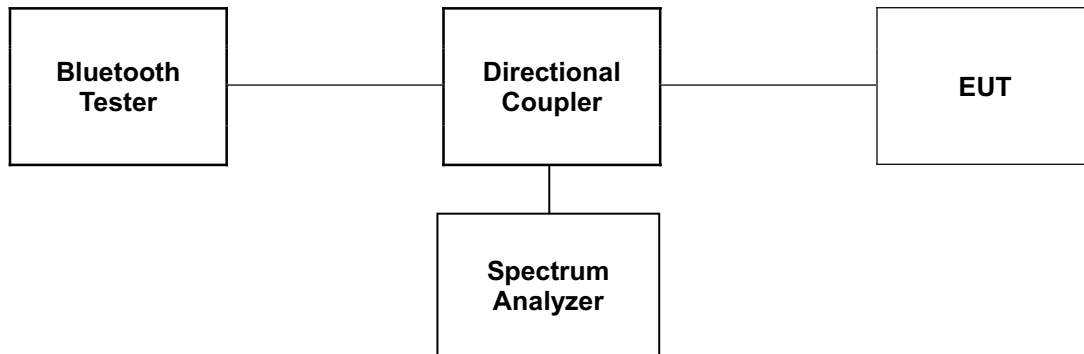

7.2. Limit

§15.247(a)(1)(iii) For frequency hopping system operating in the 2 400 – 2 483.5 MHz band, the average time of occupancy on any frequency shall not be greater than 0.4 second within a 31.6 second period.

A period time = 0.4(s) * 79 = 31.6(s)

7.3. Test Procedure

1. Check the calibration of the measuring instrument using either an internal calibrator or a known signal from an external generator.
2. Position the EUT as shown in test setup without connection to measurement instrument. Turn on the EUT and connect its antenna terminal to measurement instrument via a low loss cable.
3. Adjust the center frequency of spectrum analyzer on any frequency be measured and set spectrum analyzer to zero span mode. And then, set RBW and VBW of spectrum analyzer to proper value.
4. Measure the time duration of one transmission on the measured frequency. And then plot the result with time difference of this time duration.
5. Repeat above procedures until all frequencies measured were complete.
6. The Bluetooth has 3 type of payload, DH1, DH3, DH5 and 3-DH1, 3-DH3, 3-DH5. The hopping rate is 1 600 per second.

The results shown in this test report refer only to the sample(s) tested unless otherwise stated. This test report cannot be reproduced, except in full, without prior written permission of the Company.

7.4. Test Results

Ambient temperature : (24 ± 2) °C
 Relative humidity : 47 % R.H.

Time of occupancy on the TX channel in 31.6sec
 = time domain slot length × (hop rate ÷ number of hop per channel) × 31.6

7.4.1. Packet Type: DH1, 3-DH1

Operation Mode	Frequency	Dwell Time (ms)	Time of occupancy on the Tx Channel in 31.6 sec (ms)	Limit for time of occupancy on the Tx Channel in 31.6 sec (ms)
GFSK	2 441 MHz	0.406	129.92	400
8DPSK	2 441 MHz	0.406	129.92	400

$2\,441\text{ MHz} : 0.406\text{ (ms)} \times [(1\,600 \div 2) \div 79] \times 31.6\text{ (s)} = 129.92\text{ (ms)}$

The results shown in this test report refer only to the sample(s) tested unless otherwise stated. This test report cannot be reproduced, except in full, without prior written permission of the Company.

Operating Mode: GFSK

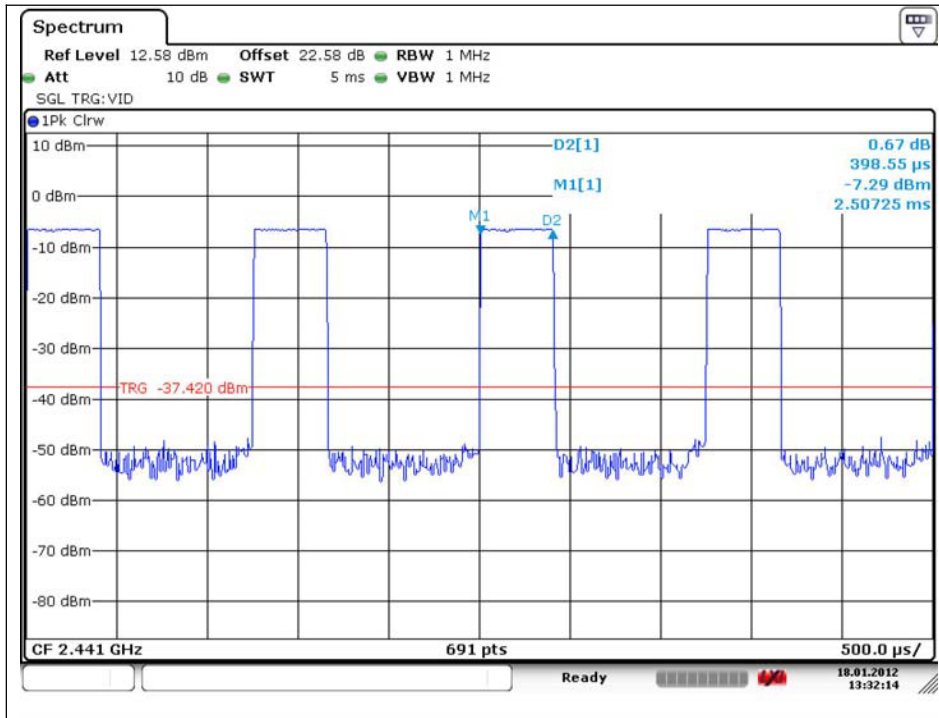

Operating Mode: 8DPSK

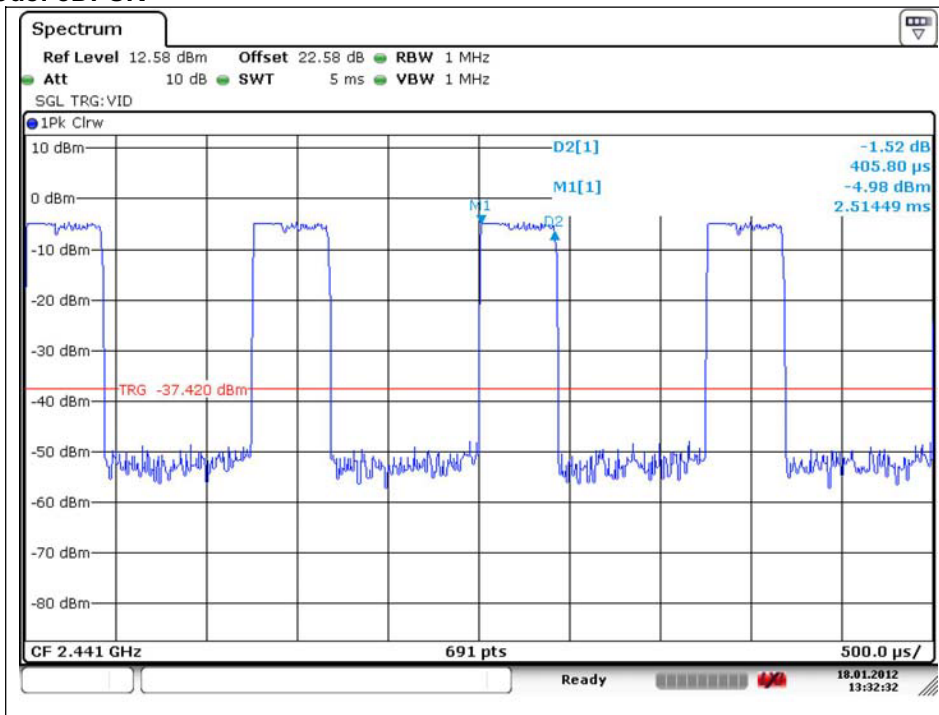

The results shown in this test report refer only to the sample(s) tested unless otherwise stated. This test report cannot be reproduced, except in full, without prior written permission of the Company.

7.4.2. Packet Type: DH3, 3-DH3

Operation Mode	Frequency	Dwell Time (ms)	Time of occupancy on the Tx Channel in 31.6 sec (ms)	Limit for time of occupancy on the Tx Channel in 31.6 sec (ms)
GFSK	2 441 MHz	1.638	262.08	400
8DPSK	2 441 MHz	1.638	262.08	400

$$2\,441\text{ MHz} : 1.638\text{ (ms)} \times [(1\,600 \div 4) \div 79] \times 31.6\text{(s)} = 262.08\text{ (ms)}$$

The results shown in this test report refer only to the sample(s) tested unless otherwise stated. This test report cannot be reproduced, except in full, without prior written permission of the Company.

Operating Mode: GFSK

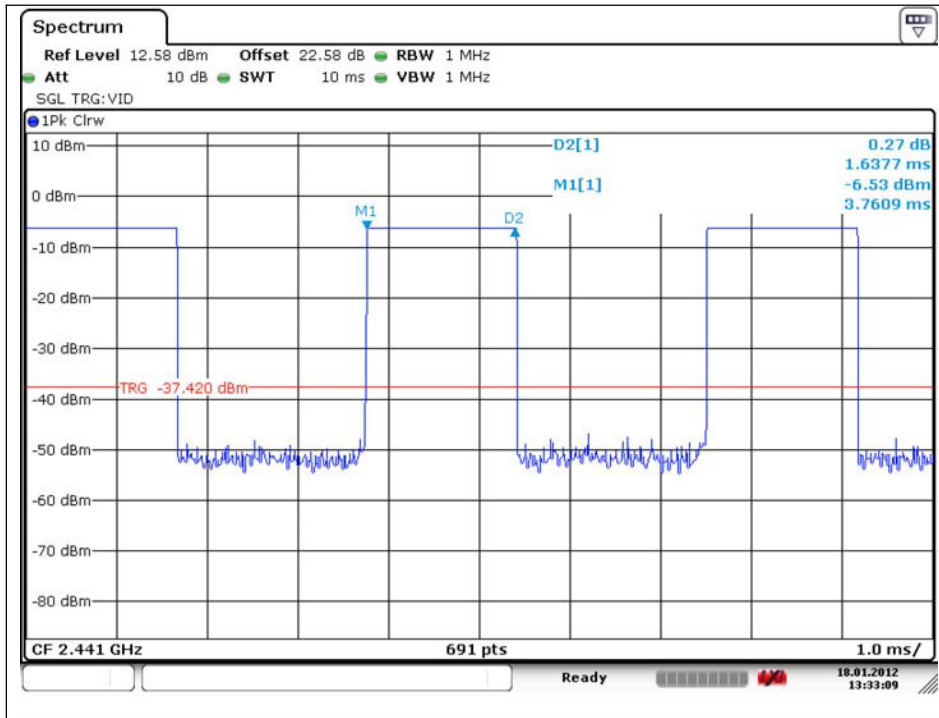

Operating Mode: 8DPSK

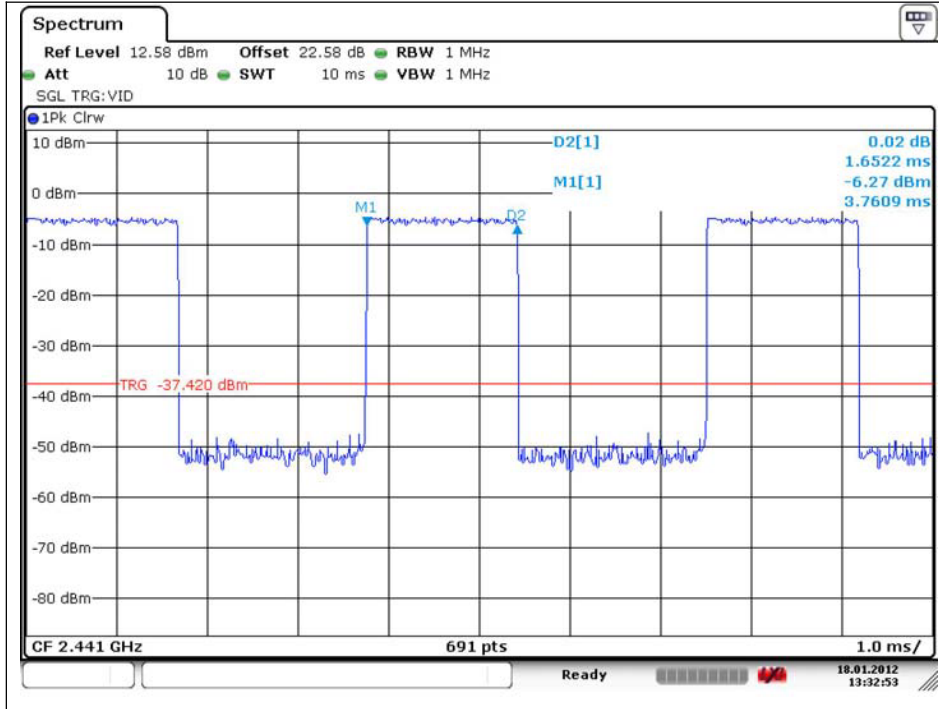

The results shown in this test report refer only to the sample(s) tested unless otherwise stated. This test report cannot be reproduced, except in full, without prior written permission of the Company.

7.4.3. Packet Type: DH5, 3-DH5

Operation Mode	Frequency	Dwell Time (ms)	Time of occupancy on the Tx Channel in 31.6 sec (ms)	Limit for time of occupancy on the Tx Channel in 31.6 sec (ms)
GFSK	2 441 MHz	2.920	311.47	400
8DPSK	2 441 MHz	2.920	311.47	400

$$2\,441\text{ MHz} : 2.920\text{ (ms)} \times [(1\,600 \div 6) \div 79] \times 31.6\text{(s)} = 311.47\text{ (ms)}$$

The results shown in this test report refer only to the sample(s) tested unless otherwise stated. This test report cannot be reproduced, except in full, without prior written permission of the Company.

Operating Mode: GFSK

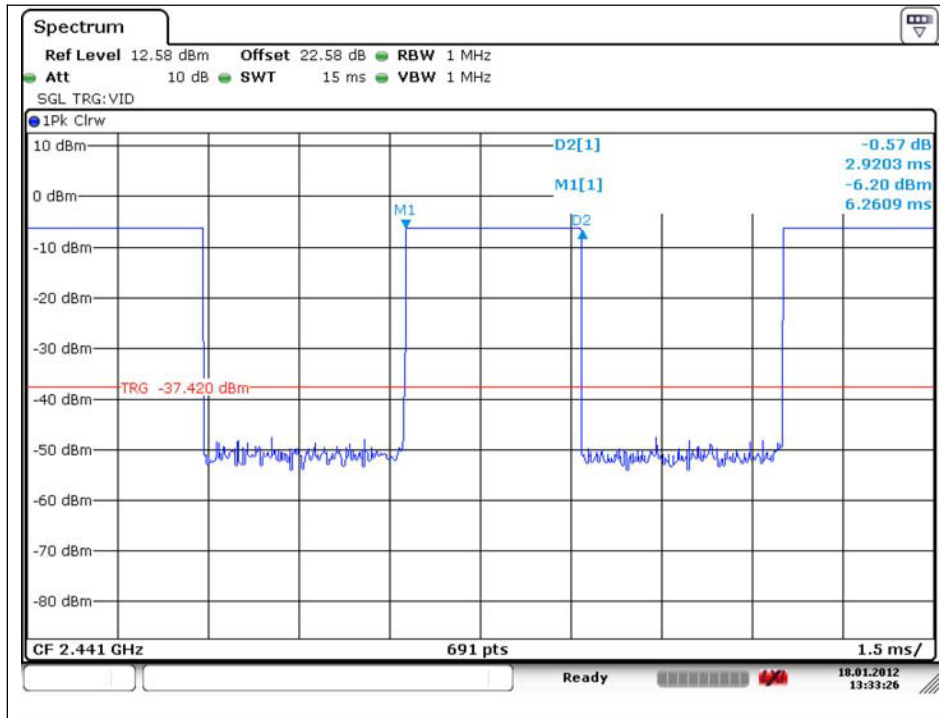

Operating Mode: 8DPSK

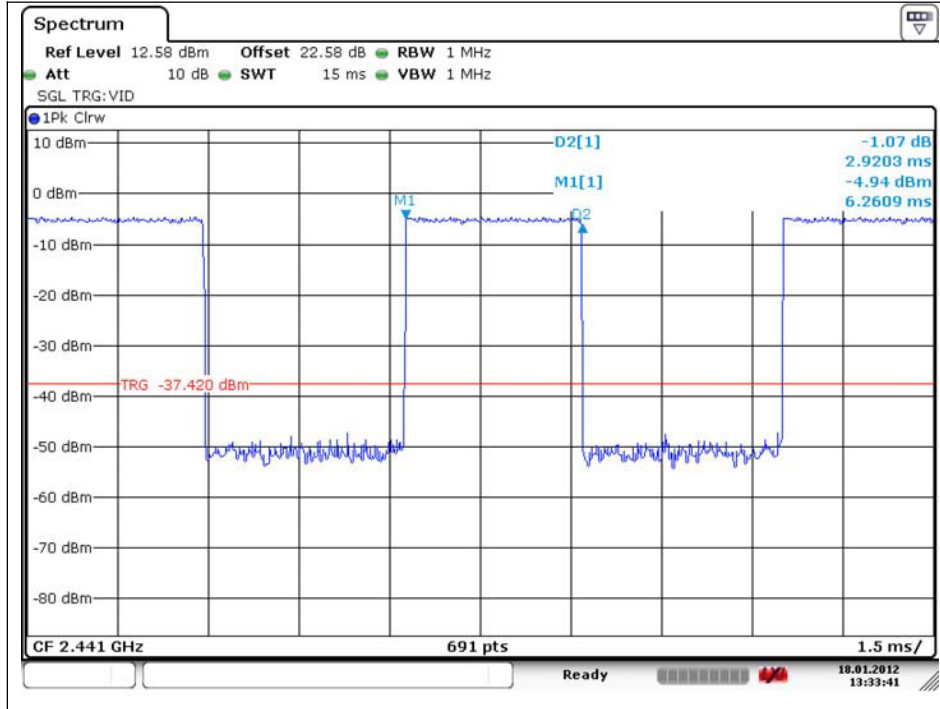

The results shown in this test report refer only to the sample(s) tested unless otherwise stated. This test report cannot be reproduced, except in full, without prior written permission of the Company.

8. Antenna Requirement

8.1. Standard Applicable

For intentional device, according to FCC 47 CFR Section §15.203, an intentional radiator shall be designed to ensure that no antenna other than that furnished by the responsible party shall be used with the device. And according to FCC 47 CFR Section §15.247 (b) if transmitting antennas of directional gain greater than 6 dB i are used, the power shall be reduced by the amount in dB that the gain of the antenna exceeds 6 dB i.

8.2. Antenna Connected Construction

Antenna used in this product is Internal type gain of 2.11 dB i.

The results shown in this test report refer only to the sample(s) tested unless otherwise stated. This test report cannot be reproduced, except in full, without prior written permission of the Company.

SGS Korea Co., Ltd. (Gunpo Laboratory) 18-34, Sanbon-dong, Gunpo-si, Gyeonggi-do, Korea, 435-040

Tel. +82 31 428 5700 / Fax. +82 31 427 2371

www.ee.sgs.com/korea

9. RF Exposure Evaluation

9.1 Environmental evaluation and exposure limit according to FCC CFR 47 part 1, 1.1307(b), 1.1310

According to FCC 1.1310 : The criteria listed in the following table shall be used to evaluate the environment impact of human exposure to radio frequency (RF) radiation as specified in §1.1307(b)

LIMITS FOR MAXIMUM PERMISSIBLE EXPOSURE (MPE)

Frequency Range (MHz)	Electric Field Strength(V/m)	Magnetic Field Strength (A/m)	Power Density (mW/cm ²)	Average Time
(A) Limits for Occupational /Control Exposures				
300 – 1 500	--	--	F/300	6
1 500 – 100 000	--	--	5	6
(B) Limits for General Population/Uncontrol Exposures				
300 – 1 500	--	--	F/1500	6
<u>1 500 – 100 000</u>	--	--	<u>1</u>	<u>30</u>

9.1.1. Friis transmission formula: $P_d = (P_{out} \cdot G) / (4 \cdot \pi \cdot R^2)$

Where P_d = power density in mW/cm²

P_{out} = output power to antenna in mW

G = gain of antenna in linear scale

π = 3.1416

R = distance between observation point and center of the radiator in cm

P_d the limit of MPE, 1 mW/cm². If we know the maximum gain of the antenna and the total power input to the antenna, through the calculation, we will know the distance where the MPE limit is reached.

The results shown in this test report refer only to the sample(s) tested unless otherwise stated. This test report cannot be reproduced, except in full, without prior written permission of the Company.

9.1.2. Test Result of RF Exposure Evaluation

Test Item : RF Exposure Evaluation Data

Test Mode : Normal Operation

9.1.3. Output Power into Antenna & RF Exposure Evaluation Distance

FHSS : GFSK

Channel	Channel Frequency (MHz)	Output Average Power to Antenna (dB m)	Antenna Gain (dB i)	Power Density at 20 cm (mW/cm ²)	LIMITS (mW/cm ²)
Low	2 402	-12.36	2.11	0.000 006	1
Middle	2 441	-11.55	2.11	0.000 007	1
High	2 480	-13.67	2.11	0.000 004	1

FHSS : 8DPSK

Channel	Channel Frequency (MHz)	Output Average Power to Antenna (dB m)	Antenna Gain (dB i)	Power Density at 20 cm (mW/cm ²)	LIMITS (mW/cm ²)
Low	2 402	-12.32	2.11	0.000 006	1
Middle	2 441	-10.80	2.11	0.000 009	1
High	2 480	-13.31	2.11	0.000 005	1

Note :

1. The power density Pd (5th column) at a distance of 20 cm calculated from the friis transmission formula is far below the limit of 1 mW/cm².

The results shown in this test report refer only to the sample(s) tested unless otherwise stated. This test report cannot be reproduced, except in full, without prior written permission of the Company.