

APPLICATION FOR CERTIFICATION

On Behalf of

LG Electronics Inc.

Wireless Speaker

Total Model No. : ACC97WK (ACC97WK-T, ACC97WK-R)

Test Model No. : ACC97WK-R

Brand: LG

FCC ID : BEJ9QK-ACC97WKR

Prepared for : LG Electronics Inc.
19-1, Cheongho-Ri, Jinwuy-Myun,
Pyungtaek-City, Kyungki-Do, 451-713
Korea.

Prepared by : Audix Technology Corporation
EMC Department
No. 53-11, Tin-Fu Tsun, Lin-Kou,
Taipei, Taiwan

Tel : (02) 2609-9301, 2609-2133

Fax: (02) 2609-9303

File Number : EM952510A
Report Number : EM-F950469
Date of Test : Nov. 08 ~ 09, 2006
Date of Report : Nov. 16, 2006

TABLE OF CONTENTS

Description	Page
TEST REPORT CERTIFICATION	4
1. GENERAL INFORMATION	5
1.1. Description of Device (EUT).....	5
1.2. Tested Supporting System Details	6
1.3. Description of Test Facility	7
1.4. Measurement Uncertainty	7
2. CONDUCTED EMISSION MEASUREMENT.....	8
2.1. Test Equipment.....	8
2.2. Block Diagram of Test Setup.....	8
2.3. Powerline Conducted Emission Limit	8
2.4. Operating Condition of EUT	9
2.5. Test Procedure	9
2.6. Conducted Emission Measurement Results.....	9
3. RADIATED EMISSION MEASUREMENT	12
3.1. Test Equipment.....	12
3.2. Test Setup	12
3.3. Radiated Emission Limits.....	14
3.4. Operating Condition of EUT	14
3.5. Test Procedure	15
3.6. Radiated Emission Measurement Results.....	15
4. 20dB BANDWIDTH MEASUREMENT	37
4.1. Test Equipment.....	37
4.2. Block Diagram of Test Setup.....	37
4.3. Specification Limits (§15.247(a)(1))	37
4.4. Operating Condition of EUT	37
4.5. Test Procedure	37
4.6. Test Results.....	38
5. CARRIER FREQUENCY SEPARATION MEASUREMENT	40
5.1. Test Equipment.....	40
5.2. Block Diagram of Test Setup.....	40
5.3. Specification Limits (§15.247(a)(1))	40
5.4. Operating Condition of EUT	40
5.5. Test Procedure	40
5.6. Test Results.....	41
6. TIME OF OCCUPANCY MEASUREMENT	43
6.1. Test Equipment.....	43
6.2. Block Diagram of Test Setup.....	43
6.3. Specification Limits (§15.247(a)(1)(iii))	43
6.4. Operating Condition of EUT	43
6.5. Test Procedure	43
6.6. Test Results.....	44
7. NUMBER OF HOPPING CHANNELS MEASUREMENT	48
7.1. Test Equipment.....	48
7.2. Block Diagram of Test Setup.....	48
7.3. Specification Limits (§15.247(a)(1)(iii))	48
7.4. Operating Condition of EUT	48
7.5. Test Procedure	48
7.6. Test Results.....	48

8. MAXIMUM PEAK OUTPUT POWER MEASUREMENT50
 8.1. Test Equipment.....50
 8.2. Block Diagram of Test Setup.....50
 8.3. Specification Limits (§15.247(b)-(1)).....50
 8.4. Operating Condition of EUT50
 8.5. Test Procedure50
 8.6. Test Results.....50

9. EMISSION LIMITATIONS MEASUREMENT51
 9.1. Test Equipment.....51
 9.2. Block Diagram of Test Setup.....51
 9.3. Specification Limits (§15.247(c)).....51
 9.4. Operating Condition of EUT51
 9.5. Test Procedure51
 9.6. Test Results.....52

10. BAND EDGES MEASUREMENT.....54
 10.1. Test Equipment.....54
 10.2. Block Diagram of Test Setup54
 10.3. Specification Limits (§15.247(c))54
 10.4. Operating Condition of EUT54
 10.5. Test Procedure54
 10.6. Test Results54

11. DEVIATION TO TEST SPECIFICATIONS56

12. PHOTOGRAPHS57
 12.1. Photos of Conducted Emission Measurement.....57
 12.2. Photos of Radiated Measurement at Semi-Anechoic Chamber.....58
 12.3. Photo of Section 4 ~ 6 & Section 9 ~ 10.....61
 12.4. Photo of Section 861

TEST REPORT CERTIFICATION

Applicant : LG Electronics Inc.
 Manufacturer #1 : LG Electronics Inc.
 Manufacturer #2 : LG Electronics (Huizhou) Inc.
 Manufacturer #3 : SHEN ZHEN KWANG SUNG Electronics H.K. Co., Ltd.
 EUT Description : Wireless Speaker
 FCC ID : BEJ9QK-ACC97WKR
 (A) TOTAL MODEL NO. : ACC97WK (ACC97WK-T,
 ACC97WK-R)
 (B) TEST MODEL NO. : ACC97WK-R
 (C) SERIAL NO. : N/A
 (D) BRAND : LG
 (E) POWER SUPPLY : AC 120V~, 60Hz
 (F) TEST VOLTAGE : AC 120V/60Hz

Measurement Procedure Used:

FCC RULES AND REGULATIONS PART 15 SUBPART B & C, FEBRUARY 2006
 AND ANSI C63.4/2003

(Receiver Unit with FCC CFR 47 Part 15B, §15.107 and §15.109)
 (Transmitter Unit with FCC CFR 47 Part 15C, §15.207 and §15.209 and §15.247)

The device described above was tested by Audix Technology Corporation to determine the maximum emission levels emanating from the device. The maximum emission levels were compared to the FCC Part 15 subpart B and C limits.

The measurement results are contained in this test report and Audix Technology Corporation is assumed full responsibility for the accuracy and completeness of these measurements. Also, this report shows that the EUT to be technically compliant with the FCC official limits.

This report applies to above tested sample only. This report shall not be reproduced in part without written approval of Audix Technology Corporation.

Date of Test: Nov. 08 ~ 09, 2006

Prepared by: Tina Huang Dec. 26, 2006
 (Tina Huang/Assistant)

Test Engineer: Ben Cheng Dec. 26, 2006
 (Ben Cheng/Section Manager)

Approved & Authorized Signer: Leon Liu Dec. 26, 2006
 (Leon Liu/Senior Manager)

1. GENERAL INFORMATION

1.1. Description of Device (EUT)

Description	:	Wireless Speaker
Total Model Number	:	ACC97WK (ACC97WK-T, ACC97WK-R) The device included a transmitter (ACC97WK-T) and receiver (ACC97WK-R) unit. The general model name is ACC97WK.
Test Model Number	:	ACC97WK-R (Receiver)
FCC ID	:	BEJ9QK-ACC97WKR
Brand Name	:	LG
Applicant	:	LG Electronics Inc. 19-1, Cheongho-Ri, Jinwuy-Myun, Pyungtaek-City, Kyungki-Do, 451-713 Korea.
Manufacturer #1	:	LG Electronics Inc. 19-1, Cheongho-Ri, Jinwuy-Myun, Pyungtaek-City, Kyungki-Do, 451-713 Korea
Manufacturer #2	:	LG Electronics (Huizhou) Inc. No. 1 Xingda Road, Huitai Industrial Park of Zhongkai Development Zone Huizhou City, Guangdong, China
Manufacturer #3	:	SHEN ZHEN KWANG SUNG Electronics H.K. Co., Ltd. Shitoushan Industrial Zone, Zhuan Chang Village, Shiyan Town, Baoan District, Shen Zhen City, Guang Dong Province, China
RX Module	:	LG, M/N WHAM2_LGRX IC:2703H-LGVISION
Fundamental Range	:	2400MHz ~ 2483.5MHz
Channel Number	:	20
Radio Technology	:	FHSS Modulation
Antenna Gain	:	2.0dBi

Power Cord : Non-Shielded, Undetachable, 2.0m (2 Pin)

Date of Receipt of Sample : Nov. 08, 2006

Date of Test : Nov. 08 ~ 09, 2006

1.2. Tested Supporting System Details

1.2.1. DVD PLAYER

Model Number : HT902

Serial Number : N/A

Brand : LG

Manufacturer : LG Electronics Ltd.

USB Cable : Shielded, Detachable, 2.2m

Power Cord : Non-Shielded, Detachable, 1.5m

1.2.2. SPEAKER*2

Model Number : LHS-761AS

Serial Number : N/A

Brand : LG

Manufacturer : LG Electronics Ltd.

Data Cable*2 : Non-Shielded, Undetachable, 5.2m
With a ferrite core

1.2.3. TRANSMITTER

Model Number : ACC97WK-T

Serial Number : N/A

Brand : LG

Manufacturer : LG Electronics Ltd.

RX Module : LG, M/N WHAM2_LGTX
IC:2703H-LGVISION

DC Power Cable : Shielded, Detachable, 2.0m

1.3. Description of Test Facility

Name of Firm : **Audix Technology Corporation**
EMC Department
 No. 53-11, Tin-Fu Tsun, Lin-Kou,
 Taipei, Taiwan

Test Location & Facility : **No. 2 Shielded Room**
 (C2/Semi-AC) No. 67-4, Tin-Fu Tsun, Lin-Kou,
 Taipei, Taiwan.

Semi-Anechoic Chamber
 No. 53-11, Tin-Fu Tsun, Lin-Kou,
 Taipei, Taiwan

May 15, 2006 File on
 Federal Communication Commission
 Registration Number: 90993

NVLAP Lab. Code : 200077-0
 (NVLAP is a NATA accredited body under Mutual Recognition Agreement)

1.4. Measurement Uncertainty

Test Item	Frequency Range	Uncertainty (dB)
Conduction Test	150kHz~30MHz	±1.73dB
Radiation Test (Distance: 10m)	30MHz~300MHz	±2.99dB
	300MHz~1000MHz	±2.73dB
Radiation Test (Distance: 3m)	30MHz~300MHz	±2.91dB
	300MHz~1000MHz	±2.94dB
	Above 1GHz	± 5.02dB

Remark : Uncertainty = $ku_c(y)$

Test Item	Uncertainty
20dB Bandwidth	± 0.2kHz
Carrier Frequency Separation	± 0.2kHz
Time Of Occupancy	± 0.03sec
Maximum peak Output power	± 0.52dBm
Emission Limitations	± 0.13dB
Band Edges	± 0.13dB

2. CONDUCTED EMISSION MEASUREMENT

2.1. Test Equipment

The following test equipment were used during the conducted measurement:
(No. 2 Shielded Room)

Item	Type	Manufacturer	Model No.	Serial No.	Last Cal.	Next Cal.
1.	Test Receiver	R&S	ESCS30	100265	Sep. 19, 06'	Sep. 18, 07'
2.	A.M.N.	R & S	ESH2-Z5	890485/023	Feb. 09, 06'	Feb. 08, 07'
3.	L.I.S.N.	Kyoritsu	KNW-407	8-855-9	Apr. 19, 06'	Apr. 18, 07'
4.	Pulse Limiter	R&S	ESH3Z2	001	Mar. 11, 06'	Mar. 10, 07'

2.2. Block Diagram of Test Setup

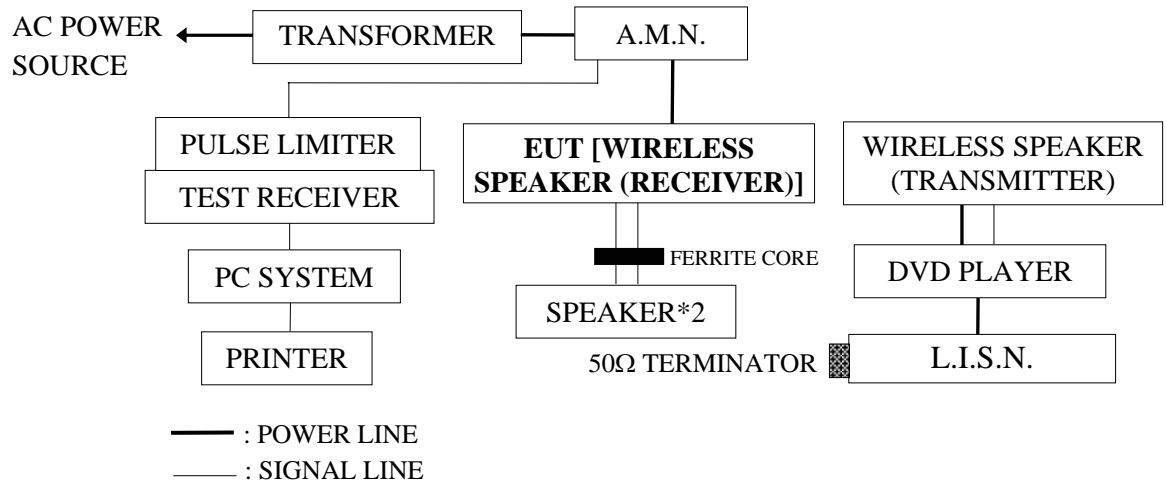

2.3. Powerline Conducted Emission Limit

Frequency	Maximum RF Line Voltage	
	Quasi-Peak Level	Average Level
150kHz ~ 500kHz	66 ~ 56 dB μ V	56 ~ 46 dB μ V
500kHz ~ 5MHz	56 dB μ V	46 dB μ V
5MHz ~ 30MHz	60 dB μ V	50 dB μ V

Remark1.: If the average limit is met when using a Quasi-Peak detector, the EUT shall be deemed to meet both limits and measurement with the average detector is unnecessary.

2.: The lower limit applies at the band edges.

2.4. Operating Condition of EUT

- 2.4.1. Setup the EUT and simulator as shown on 2.2.
- 2.4.2. Turn on the power of all equipments.
- 2.4.3. The DVD player sent 1kHz audio signal to Wireless Speaker (receiver) through Wireless Speaker (transmitter) and sent the sound to speaker.

2.5. Test Procedure

The EUT was put on table which was above the ground by 80cm and it's power cord connected to the power mains through a line impedance stabilization network (L.I.S.N. #1) and the other peripheral devices power cord were connected to the power mains through a line impedance stabilization network (L.I.S.N. #2) This provided a 50 ohm coupling impedance for the measuring equipment. (Please refer to the block diagram of the test setup and photographs.) Both sides of A.C. line were checked for maximum conducted interference. In order to find the maximum emission, the relative positions simulators of the interface cables should be manipulated according to FCC ANSI C63.4-2003 during conducted measurement.

The bandwidth of the R&S Test Receiver ESCS30 was set at 9kHz.

The frequency range from 150kHz to 30MHz was checked.

All the final readings from Test Receiver were measured with the Quasi-Peak detector and Average detector. (Remark: If the Average limit is met when using a Quasi-Peak detector, the Average detector is unnecessary)

2.6. Conducted Emission Measurement Results

PASSED.

(All the emissions not reported below are too low against the prescribed limits.)

EUT was performed during this section testing and all the test results are attached in next pages.

EUT : Wireless Speaker M/N : ACC97WK-R

Test Date : Nov. 09, 2006 Temperature : 27 Humidity : 46%

Reference Test Data No.: Neutral: # 1 ; Line: # 2



AUDIX TECHNOLOGY Corp. EMC Laboratory
 No.53-11, Tin-fu Tsun, Lin-kou Hsiang, Taipei
 County, Taiwan R.O.C. Post Code:24443
 Tel:02-26092133 Fax:02-26099303
 Email:ttmc@ttmc.com.tw

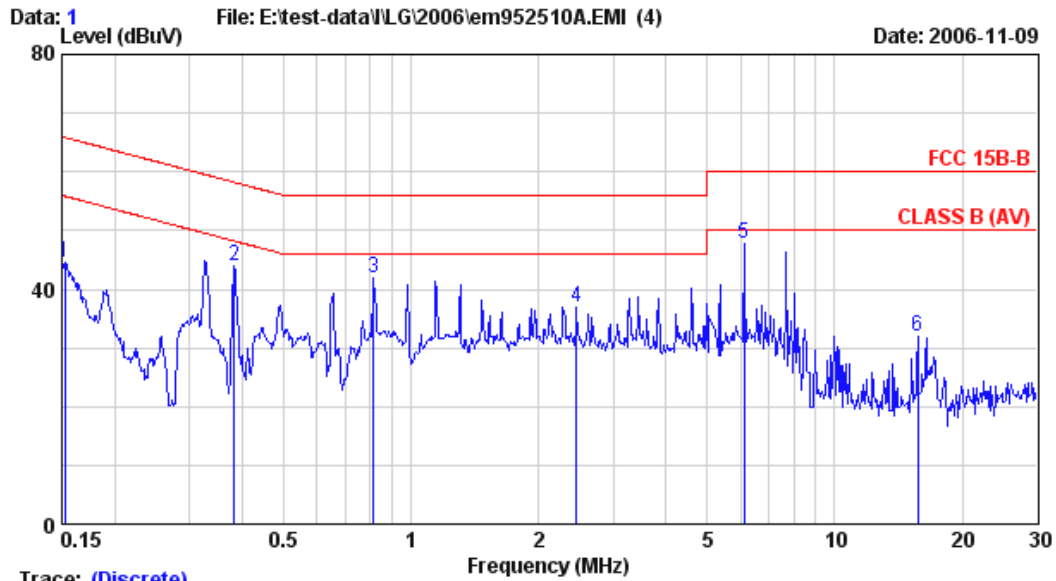

Trace: (Discrete)

Site	: No.2 Shielded room	Data	: 1
Condition	: ESH2-Z5	Phase	: NEUTRAL
Limit	: FCC 15B-B		
Env. / Ins.	: 27°C,46% / ESCS 30	Engineer:	: Ada Huang
EUT	: Wireless Speaker M/N:ACC97WK		
Power Rating	: 120Vac/60Hz		
Test Mode	: operating (ACC97WK-R)		

Freq. (MHz)	LISN Factor (dB)	Cable Loss (dB)	Reading (dBμV)	Emission Level (dBμV)	Limits (dBμV)	Margin (dB)	Remark
1	0.10	0.24	44.22	44.56	65.87	21.31	QP
2	0.10	0.32	43.48	43.90	58.21	14.31	QP
3	0.18	0.38	41.23	41.79	56.00	14.21	QP
4	0.20	0.40	36.37	36.97	56.00	19.03	QP
5	0.25	0.54	46.84	47.62	60.00	12.38	QP
6	0.41	0.70	30.88	32.00	60.00	28.00	QP

Remarks: 1.Emission Level= LISN Factor + Cable Loss + Reading.
 2.If the average limit is met when using a quasi-peak detector ,the EUT shall be deemed to meet both limits and measurement with average detector is unnecessary.



AUDIX TECHNOLOGY Corp. EMC Laboratory
 No.53-11, Tin-fu Tsun, Lin-kou Hsiang, Taipei
 County, Taiwan R.O.C. Post Code:24443
 Tel:02-26092133 Fax:02-26099303
 Email:ttemc@ttemc.com.tw

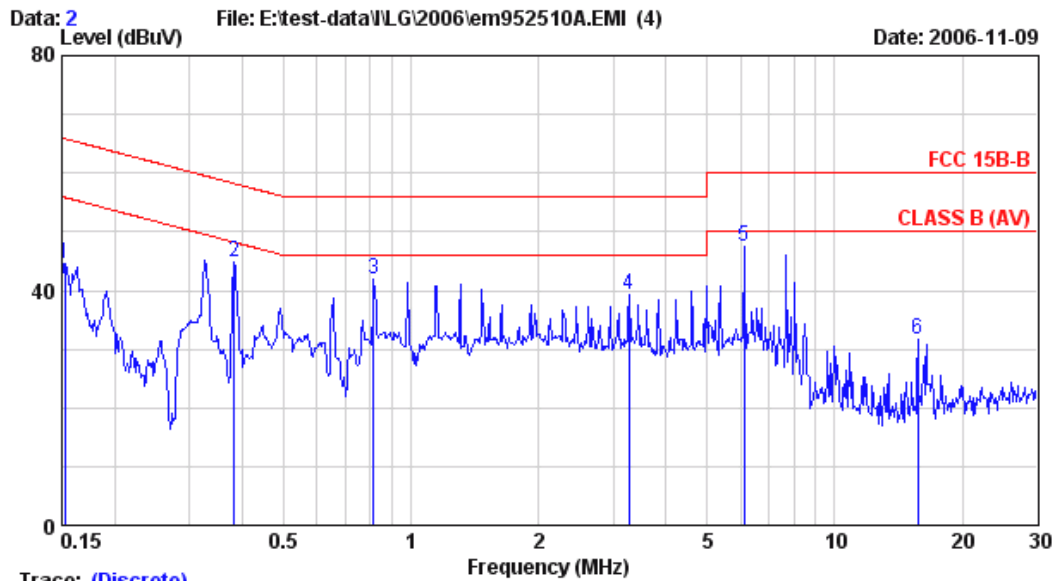

Trace: (Discrete)

Site	: No.2 Shielded room	Data	: 2
Condition	: ESH2-Z5	Phase	: LINE
Limit	: FCC 15B-B		
Env. / Ins.	: 27°C,46% / ESCS 30	Engineer:	Ada Huang
EUT	: Wireless Speaker M/N:ACC97WK		
Power Rating	: 120Vac/60Hz		
Test Mode	: operating (ACC97WK-R)		

	LISN		Cable		Emission			
Freq. (MHz)	Factor (dB)	Loss (dB)	Reading (dBµV)	Level (dBµV)	Limits (dBµV)	Margin (dB)	Remark	
1	0.152	0.10	0.24	44.18	44.52	65.87	21.35	QP
2	0.383	0.10	0.32	44.52	44.94	58.21	13.27	QP
3	0.817	0.18	0.38	41.36	41.92	56.00	14.08	QP
4	3.276	0.20	0.40	38.63	39.23	56.00	16.77	QP
5	6.121	0.25	0.54	46.58	47.36	60.00	12.64	QP
6	15.718	0.44	0.70	30.64	31.79	60.00	28.21	QP

Remarks: 1.Emission Level= LISN Factor + Cable Loss + Reading.
 2.If the average limit is met when using a quasi-peak detector ,the EUT shall be deemed to meet both limits and measurement with average detector is unnecessary.

3. RADIATED EMISSION MEASUREMENT

3.1. Test Equipment

The following test equipment was used during the radiated emission measurement:

3.1.1. For Frequency 30MHz~1000MHz (at Semi-Anechoic Chamber)

Item	Type	Manufacturer	Model No.	Serial No.	Last Cal.	Next Cal.
1.	Spectrum Analyzer	HP	8593EM	3826A00272	Aug. 23, 06'	Aug. 22, 07'
2.	Test Receiver	R & S	ESCS30	100339	Mar. 21, 06'	Mar. 20, 07'
3.	Pre-Amplifier	HP	8447D	2944A06305	Mar. 09, 06'	Mar. 08, 07'
4.	Biconical Antenna	CHASE	VBA6106A	1264	Apr. 19, 06'	Apr. 18, 07'
5.	Log Periodic Antenna	Schwarzbeck	UHALP91 08-A	0139	Apr. 19, 06'	Apr. 18, 07'

3.1.2. For Frequency Above 1GHz (at Semi-Anechoic Chamber)

Item	Type	Manufacturer	Model No.	Serial No.	Last Cal.	Next Cal.
1.	Spectrum Analyzer	HP	8593EM	3826A00272	Aug. 23, 06'	Aug. 22, 07'
2.	Pre-Amplifier	HP	8449B	3008A01284	Jun. 30, 06'	Jun. 29, 07'
3.	3.5G High Pass Filter	HP	84300- 80038	005	Jan. 11, 06'	Jan. 10, 07'
4.	Horn Antenna	EMCO	3115	9112-3775	Jun. 01, 06'	May 31, 07'
5.	Horn Antenna	EMCO	3116	2653	Oct. 04, 06'	Oct. 03, 07'

3.2. Test Setup

3.2.1. For System Operating mode

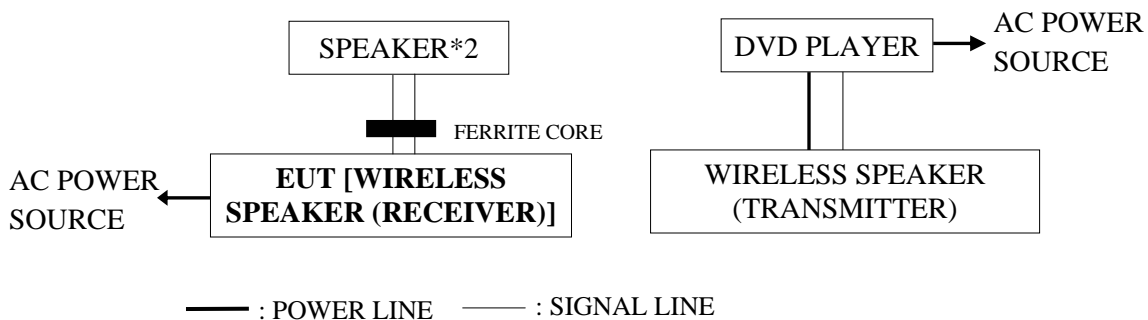

3.2.2. For Transmitting and Receiving modes



3.2.3. Semi-Anechoic Chamber (3m) Setup Diagram for 30-1000MHz

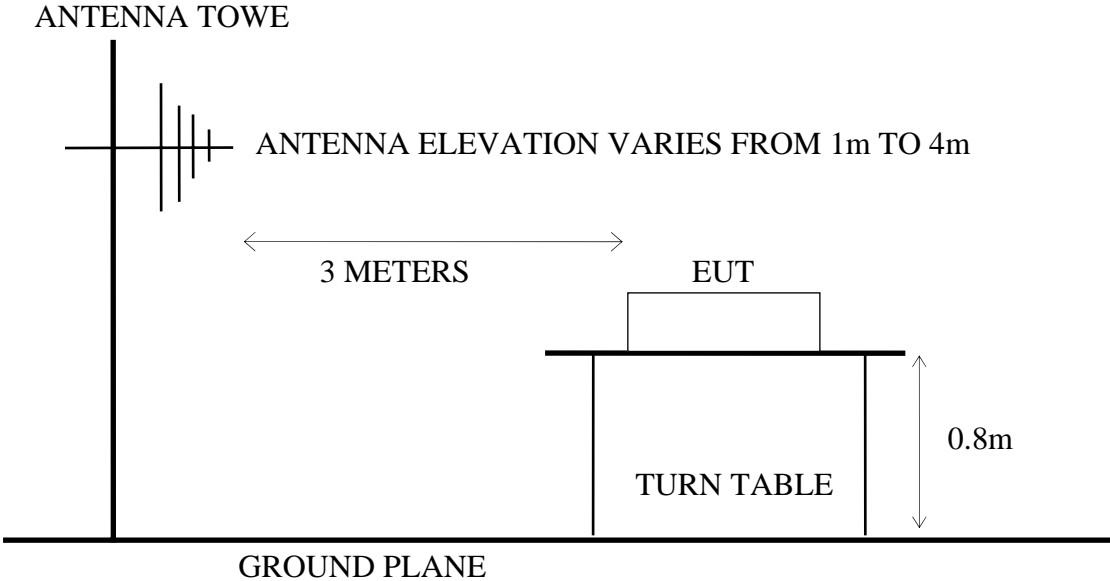

3.2.4. Semi-Anechoic Chamber (3m) Setup Diagram for above 1GHz

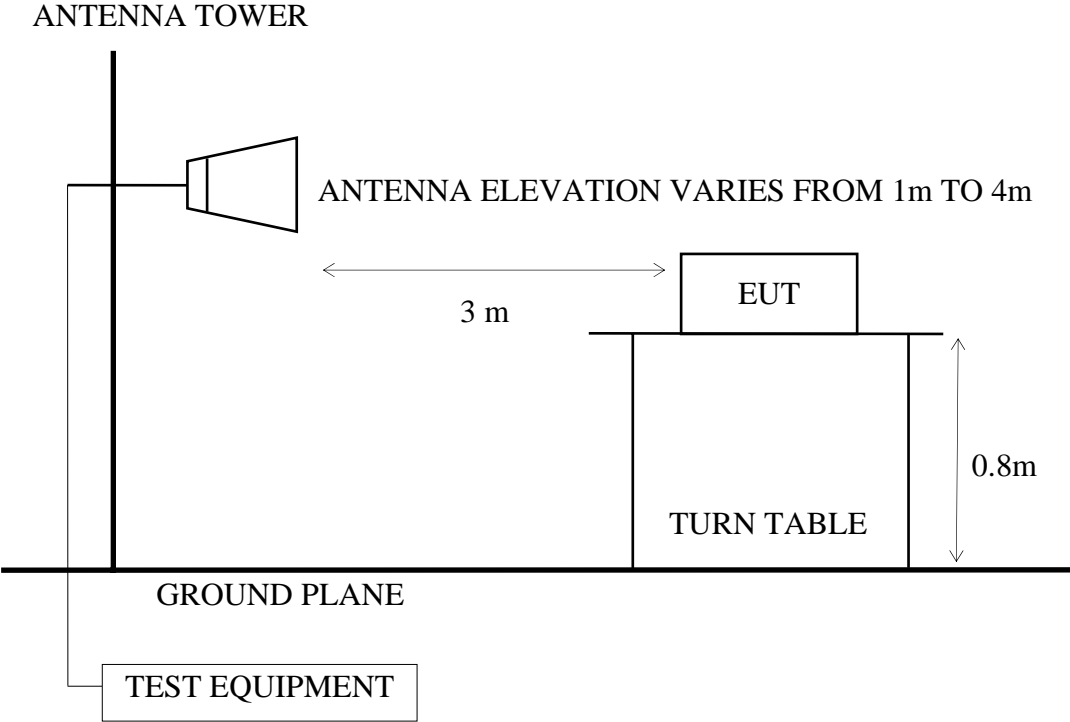

3.3. Radiated Emission Limits

3.3.1. §15.109/CISPR 22, Class B Radiated Emission Limits

FREQUENCY (MHz)	DISTANCE (Meters)	FIELD STRENGTHS LIMITS (dB μ V/m)
30 ~ 230	3	40
230 ~ 1000	3	47

- Note :
- (1) The tighter limit applies at the edge between two frequency bands.
 - (2) Distance refers to the distance in meters between the measuring instrument antenna and the closed point of any part of the E.U.T.

3.3.2. §15.209/§15.109 Class B Radiated Emission Limits

Frequency MHz	Distance Meters	Field Strengths Limits	
		μ V/m	dB μ V/m
30 ~ 88	3	100	40.0
88 ~ 216	3	150	43.5
216 ~ 960	3	200	46.0
Above 960	3	500	54.0
Above 1000	3	74.0 dB μ V/m (Peak) 54.0 dB μ V/m (Average)	

- Remark :
- (1) Emission level (dB μ V/m) = 20 log Emission level (μ V/m)
 - (2) The tighter limit applies at the edge between two frequency bands.
 - (3) Distance refers to the distance in meters between the measuring instrument antenna and the closed point of any part of the device or system.
 - (4) The limits in this table are based on CFR 47 Part 15.205(a)(b) and Part 15.209 (a).
 - (5) The over 1GHz limit, FCC limit is used based on CFR 47 Part 15.35 (b) and Part 15.205(b) & Part 15.209(e) and Part 15.207(c).

3.4. Operating Condition of EUT

Test Mode: Operation

- 3.4.1. Setup the EUT (Wireless Speaker) and simulator as shown on 3.2.1.
- 3.4.2. Turn on the power of all equipment.
- 3.4.3. The DVD player sent 1kHz audio signal to Wireless Speaker (receiver) through Wireless Speaker (transmitter) and sent the sound to speaker.

Test Mode: Transmitter & Receiver

- 3.4.4. Setup the EUT (Wireless Speaker) and simulator as shown on 3.2.2
- 3.4.5. Turn on the power of all equipment.
- 3.4.6. The EUT (Wireless Speaker) was on normal function status (transmitting and receiving) during all testing.

3.5. Test Procedure

The EUT and its simulators were placed on a turn table which was 0.8 meter above the ground. The turn table rotated 360 degrees to determine the position of the maximum emission level. EUT was set 3 meters away from the receiving antenna which was mounted on a antenna tower. The antenna moved up and down between 1 to 4 meters to find out the maximum emission level. Broadband antenna such as calibrated biconical and log-periodical antenna or horn antenna were used as a receiving antenna. Both horizontal and vertical polarization of the antenna were set on measurement. In order to find the maximum emission, all of the interface cables were manipulated according to FCC ANSI C63.4-2003 regulation.

The bandwidth of the R&S Test Receiver ESCS30 was set at 120kHz. (For 30MHz to 1000MHz)

The resolution bandwidth and video bandwidth of test spectrum analyzer is 1MHz for peak detection (PK) at frequency above 1GHz.

The resolution bandwidth of test spectrum analyzer is 1MHz and the video bandwidth is 10Hz for average detection (AV) at frequency above 1GHz.

The frequency range from 30MHz to 25GHz (Up to 10th harmonics from fundamental frequency) was checked.

3.6. Radiated Emission Measurement Results

PASSED. All the emissions not reported below are too low against the official limits.

EUT : Wireless Speaker M/N : ACC97WK-R

Test Date : Nov. 08, 2006 Temperature : 25 Humidity : 63%

For Frequency Range 30MHz~1000MHz:

The EUT with following test modes were performed during this section testing and all the test results are listed in section 3.6.1.

No.	Test Unit	Test Mode and Frequency		Reference Test Data No.	
				Horizontal	Vertical
1.	System	Operation		# 2, # 3	# 1, # 4
2.	Transmitter	Transmitting	2403.328MHz (CH0)	# 9	# 10
3.			2442.240MHz (CH19)	# 10	# 9
4.			2479.104MHz (CH37)	# 9	# 10
5.	Receiver	Receiving	2442.240MHz (CH19)	# 10	# 9

* Above all final readings were measured with Quasi-Peak detector.

For Frequency above 1GHz:

The EUT with following test modes were performed during this section testing and all the test results are listed in section 3.6.2.

No.	Test Mode and Frequency	
1.	Transmitting	2403.328MHz (CH0)
2.		2442.240MHz (CH19)
3.		2479.104MHz (CH37)
4.	Receiving	2442.240MHz (CH19)

* Above all final readings were measured with Peak detector and Average detector.

For Restricted Bands:

The EUT was tested in restricted bands and all the test results are listed in section 3.6.3. (The restricted bands defined in part 15.205(a))

No.	Test Mode and Frequency		Reference Test Data No.	
			Horizontal	Vertical
1.	Transmitting	2403.328MHz (CH0)	# 8, # 5	# 7 , # 6
2.		2479.104MHz (CH37)	# 1, # 4	# 2, # 3

3.6.1. 30MHz~ 1000MHz Frequency Range Measurement Result



AUDIX Corp. EMC Laboratory
 No.53-11, Tin-fu Tsun, Lin-kou Hsiang, Taipei
 County, Taiwan R.O.C. Post Code:24443
 Tel:+886-2-26092133 Fax:+886-2-26099303
 Email:ttemc@ttemc.com.tw

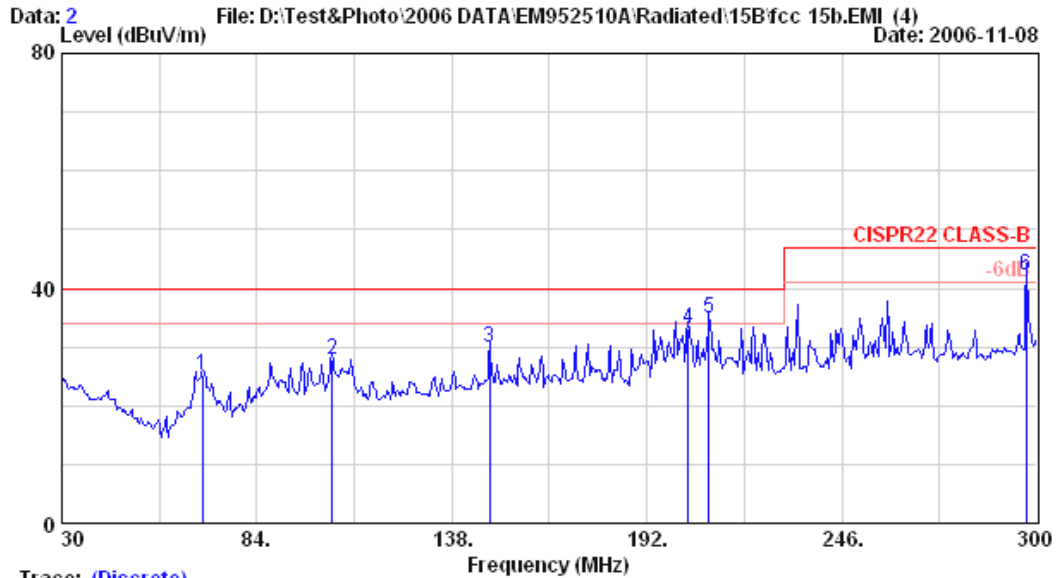

Trace: (Discrete)

Site no. : A/C Chamber Data no. : 2
 Dis. / Ant. : 3m VBA6106A(1264)2006 Ant. pol. : HORIZONTAL
 Limit : CISPR22 CLASS-B
 Env. / Ins. : 8593EM 25°C/63% Engineer : Alvin_Yang
 EUT : Wireless Speaker M/N:ACC97WK
 Power Rating : 120Vac/60Hz
 Test Mode : Operating

	Ant.	Cable	Emission		Limits	Margin	Remark
Freq. (MHz)	Factor (dB/m)	Loss (dB)	Reading (dBµV)	Level (dBµV/m)	(dBµV/m)	(dB)	
1	68.880	11.93	1.70	11.53	25.16	40.00	14.84 QP
2	104.790	17.58	2.15	8.26	27.98	40.00	12.02 QP
3	148.530	20.59	2.60	6.71	29.90	40.00	10.10 QP
4	203.340	21.99	3.10	8.06	33.15	40.00	6.85 QP
5	209.280	21.79	3.16	9.82	34.77	40.00	5.23 QP
6	297.030	26.62	4.00	11.52	42.14	47.00	4.86 QP

Remarks: 1. Emission Level= Antenna Factor + Cable Loss + Reading.
 2. The emission levels that are 20dB below the official limit are not reported.



AUDIX Corp. EMC Laboratory
 No.53-11, Tin-fu Tsun, Lin-kou Hsiang, Taipei
 County, Taiwan R.O.C. Post Code:24443
 Tel:+886-2-26092133 Fax:+886-2-26099303
 Email:ttemc@ttemc.com.tw

Data: 3 File: D:\Test&Photo\2006 DATA\EM952510A Radiated\15B\fcc 15b.EMI (4) Date: 2006-11-08

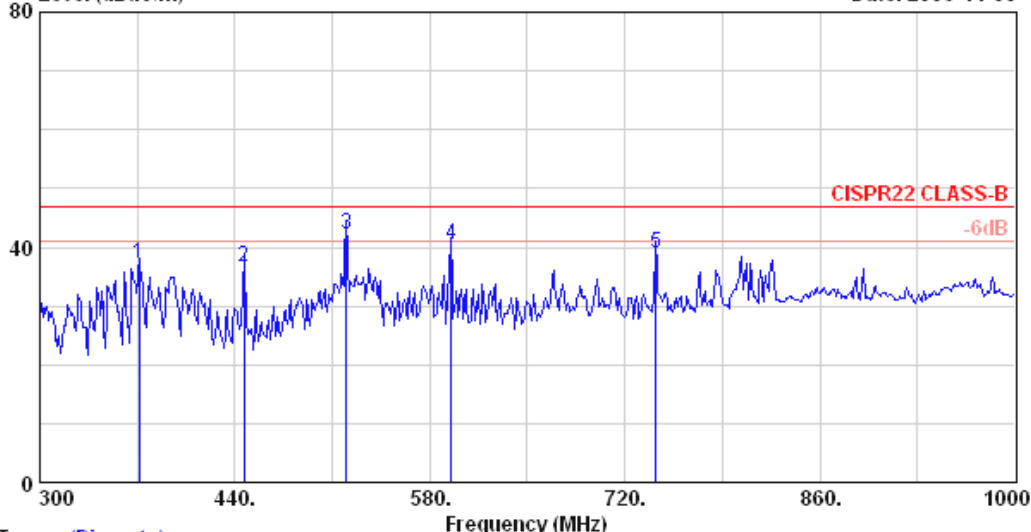

Trace: (Discrete)

Site no. : A/C Chamber Data no. : 3
 Dis. / Ant. : 3m UHALP9108A(0139)2006 Ant. pol. : HORIZONTAL
 Limit : CISPR22 CLASS-B
 Env. / Ins. : 8593EM 25°C/63% Engineer : Alvin_Yang
 EUT : Wireless Speaker M/N:ACC97WK
 Power Rating : 120Vac/60Hz
 Test Mode : Operating

	Freq. (MHz)	Ant. Factor (dB/m)	Cable Loss (dB)	Reading (dBµV)	Emission Level (dBµV/m)	Limits (dBµV/m)	Margin (dB)	Remark
1	371.400	17.08	4.60	15.45	37.13	47.00	9.87	QP
2	446.300	17.58	5.40	13.63	36.61	47.00	10.39	QP
3	519.800	19.99	6.90	15.22	42.11	47.00	4.89	QP
4	595.400	20.94	6.20	13.41	40.55	47.00	6.45	QP
5	742.400	22.47	6.70	9.78	38.95	47.00	8.05	QP

Remarks: 1. Emission Level= Antenna Factor + Cable Loss + Reading.
 2. The emission levels that are 20dB below the official limit are not reported.



AUDIX Corp. EMC Laboratory
 No.53-11, Tin-fu Tsun, Lin-kou Hsiang, Taipei
 County, Taiwan R.O.C. Post Code:24443
 Tel:+886-2-26092133 Fax:+886-2-26099303
 Email:ttemc@ttemc.com.tw

Data: 1 File: D:\Test&Photo\2006 DATA\EM952510A Radiated\15Bfcc 15b.EMI (4) Date: 2006-11-08

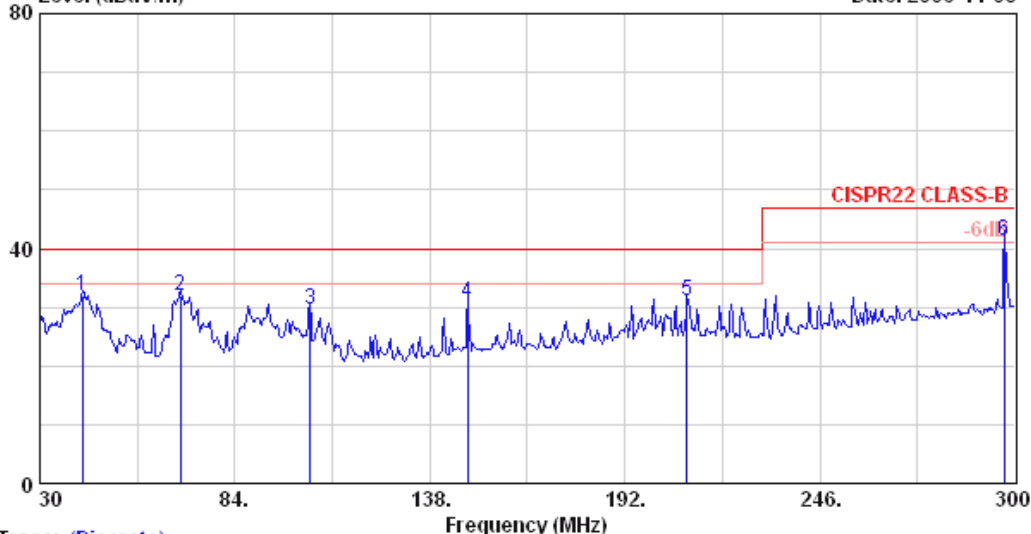

Trace: (Discrete)
 Site no. : A/C Chamber Data no. : 1
 Dis. / Ant. : 3m VBA6106A(1264)2006 Ant. pol. : VERTICAL
 Limit : CISPR22 CLASS-B
 Env. / Ins. : 8593EM 25°C/63% Engineer : Alvin_Yang
 EUT : Wireless Speaker M/N:ACC97WK
 Power Rating : 120Vac/60Hz
 Test Mode : Operating

	Ant.	Cable	Emission		Limits	Margin	Remark
Freq. (MHz)	Factor (dB/m)	Loss (dB)	Reading (dBuV)	Level (dBuV/m)	(dBuV/m)	(dB)	
1	41.880	19.86	1.30	10.80	31.96	40.00	8.04 QP
2	68.880	11.93	1.70	18.35	31.98	40.00	8.02 QP
3	104.790	17.58	2.15	9.99	29.71	40.00	10.29 QP
4	148.530	20.59	2.60	7.65	30.84	40.00	9.16 QP
5	209.280	21.79	3.16	6.21	31.16	40.00	8.84 QP
6	297.030	26.62	4.00	10.60	41.22	47.00	5.78 QP

Remarks: 1. Emission Level= Antenna Factor + Cable Loss + Reading.
 2. The emission levels that are 20dB below the official limit are not reported.



AUDIX Corp. EMC Laboratory
 No.53-11, Tin-fu Tsun, Lin-kou Hsiang, Taipei
 County, Taiwan R.O.C. Post Code:24443
 Tel:+886-2-26092133 Fax:+886-2-26099303
 Email:ttemc@ttemc.com.tw

Data: 4 File: D:\Test&Photo\2006 DATA\EM952510A\Radiated\15B\fcc 15b.EMI (4) Date: 2006-11-08

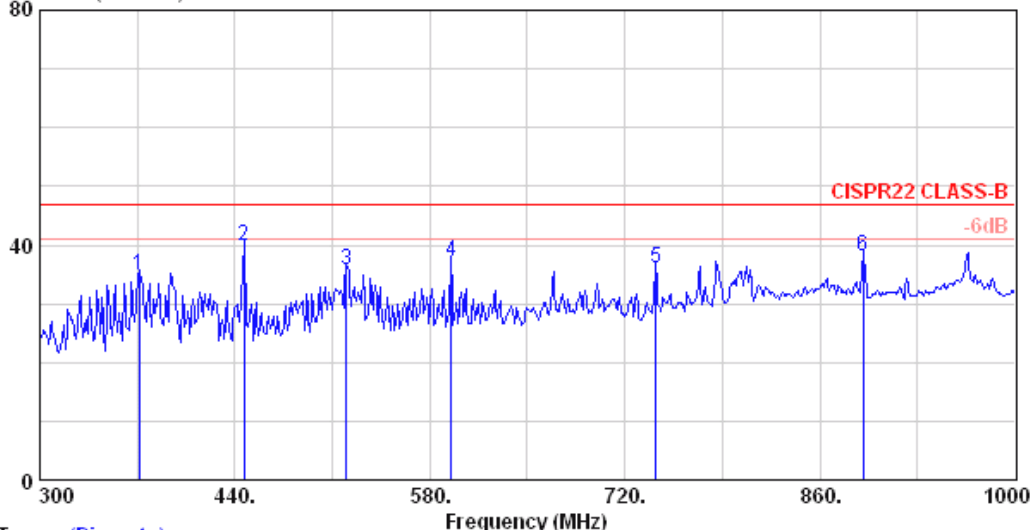

Trace: (Discrete)

Site no. : A/C Chamber Data no. : 4
 Dis. / Ant. : 3m UHALP9108A(0139)2006 Ant. pol. : VERTICAL
 Limit : CISPR22 CLASS-B
 Env. / Ins. : 8593EM 25*C/63% Engineer : Alvin_Yang
 EUT : Wireless Speaker M/N:ACC97WK
 Power Rating : 120Vac/60Hz
 Test Mode : Operating

	Freq.	Ant.	Cable	Emission		Limits	Margin	Remark
	(MHz)	Factor	Loss	Reading	Level	(dBuV/m)	(dB)	
		(dB/m)	(dB)	(dBuV)	(dBuV/m)			
1	371.400	17.08	4.60	13.19	34.87	47.00	12.13	QP
2	446.300	17.58	5.40	16.86	39.84	47.00	7.16	QP
3	519.800	19.99	6.90	8.97	35.86	47.00	11.14	QP
4	595.400	20.94	6.20	9.94	37.08	47.00	9.92	QP
5	742.400	22.47	6.70	7.01	36.18	47.00	10.82	QP
6	890.800	25.06	7.30	5.82	38.17	47.00	8.83	QP

Remarks: 1. Emission Level= Antenna Factor + Cable Loss + Reading.
 2. The emission levels that are 20dB below the official limit are not reported.



AUDIX Corp. EMC Laboratory
 No.53-11, Tin-fu Tsun, Lin-kou Hsiang, Taipei
 County, Taiwan R.O.C. Post Code:24443
 Tel:+886-2-26092133 Fax:+886-2-26099303
 Email:ttemc@ttemc.com.tw

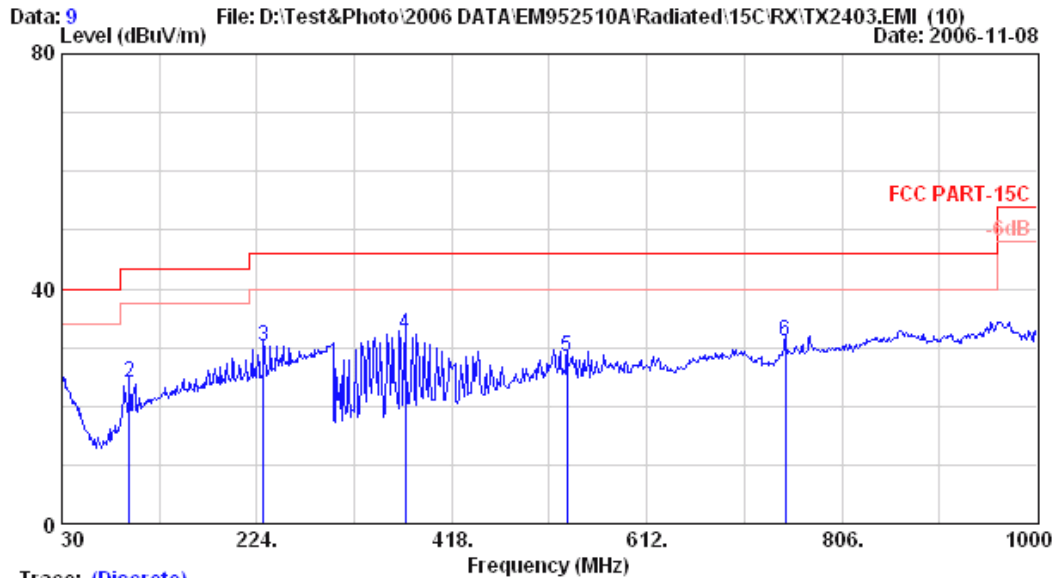

Trace: (Discrete)

Site no. : A/C Chamber Data no. : 9
 Dis. / Ant. : 3m VBA6106A/UHALP9108A Ant. pol. : HORIZONTAL
 Limit : FCC PART-15C
 Env. / Ins. : 8593EM 25°C/63% Engineer : Alvin_Yang
 EUT : Wireless Speaker M/N:ACC97WK-R
 Power Rating : 120Vac/60Hz
 Test Mode : TX2403.328MHz

	Freq. (MHz)	Ant. Factor (dB/m)	Cable Loss (dB)	Reading (dBµV)	Emission Level (dBµV/m)	Limits (dBµV/m)	Margin (dB)	Remark
1	30.000	24.86	1.10	-1.54	24.42	40.00	15.58	
2	96.930	16.75	2.05	5.26	24.06	43.50	19.44	
3	230.790	22.17	3.30	4.86	30.32	46.00	15.68	
4	371.440	17.08	4.60	10.42	32.10	46.00	13.90	
5	532.460	19.64	7.00	1.79	28.43	46.00	17.57	
6	749.740	23.25	6.70	1.08	31.03	46.00	14.97	

Remarks: 1. Emission Level= Antenna Factor + Cable Loss + Reading.
 2. The emission levels that are 20dB below the official limit are not reported.



AUDIX Corp. EMC Laboratory
 No.53-11, Tin-fu Tsun, Lin-kou Hsiang, Taipei
 County, Taiwan R.O.C. Post Code:24443
 Tel:+886-2-26092133 Fax:+886-2-26099303
 Email:ttemc@ttemc.com.tw

Data: 10 File: D:\Test&Photo\2006 DATA\EM952510A Radiated\15C RX\TX2403.EMI (10) Date: 2006-11-08

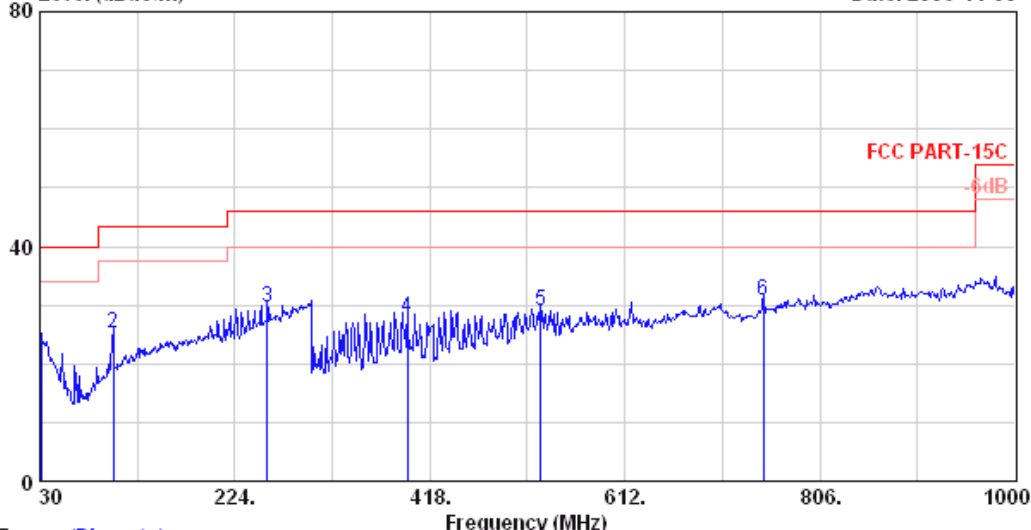

Trace: (Discrete)

Site no. : A/C Chamber Data no. : 10
 Dis. / Ant. : 3m VBA6106A/UHALP9108A Ant. pol. : VERTICAL
 Limit : FCC PART-15C
 Env. / Ins. : 8593EM 25°C/63% Engineer : Alvin_Yang
 EUT : Wireless Speaker M/N:ACC97WK-R
 Power Rating : 120Vac/60Hz
 Test Mode : TX2403.328MHz

	Freq. (MHz)	Ant. Factor (dB/m)	Cable Loss (dB)	Reading (dBuV)	Emission Level (dBuV/m)	Limits (dBuV/m)	Margin (dB)	Remark
1	30.970	24.81	1.10	-1.85	24.06	40.00	15.94	
2	102.750	17.40	2.10	5.77	25.27	43.50	18.23	
3	256.010	24.28	3.50	1.83	29.61	46.00	16.39	
4	395.690	17.60	4.71	5.46	27.77	46.00	18.23	
5	528.580	19.69	6.90	2.56	29.14	46.00	16.86	
6	749.740	23.25	6.70	0.75	30.70	46.00	15.30	

Remarks: 1. Emission Level= Antenna Factor + Cable Loss + Reading.
 2. The emission levels that are 20dB below the official limit are not reported.



AUDIX Corp. EMC Laboratory
 No.53-11, Tin-fu Tsun, Lin-kou Hsiang, Taipei
 County, Taiwan R.O.C. Post Code:24443
 Tel:+886-2-26092133 Fax:+886-2-26099303
 Email:ttemc@ttemc.com.tw

Data: 10 File: D:\Test&Photo\2006 DATA\EM952510A Radiated\15C RX\TX2442.EMI (10) Date: 2006-11-08
 Level (dBuV/m)

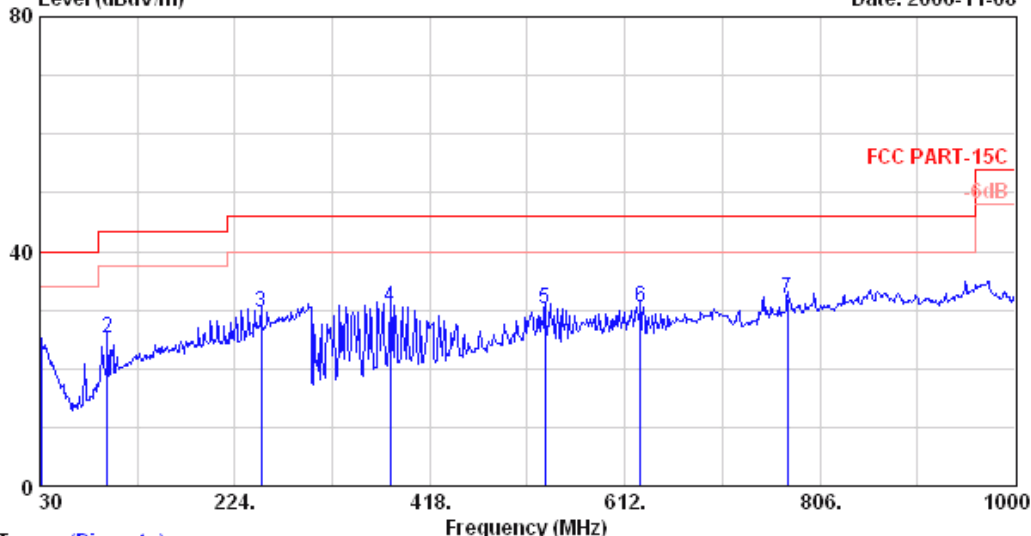

Trace: (Discrete)
 Site no. : A/C Chamber Data no. : 10
 Dis. / Ant. : 3m VBA6106A/UHALP9108A Ant. pol. : HORIZONTAL
 Limit : FCC PART-15C
 Env. / Ins. : 8593EM 25+C/63% Engineer : Alvin_Yang
 EUT : Wireless Speaker M/N:ACC97WK-R
 Power Rating : 120Vac/60Hz
 Test Mode : TX2442.240MHz

	Ant.	Cable	Emission				
Freq. (MHz)	Factor (dB/m)	Loss (dB)	Reading (dBµV)	Level (dBµV/m)	Limits (dBµV/m)	Margin (dB)	Remark
1	30.970	24.81	1.10	-1.57	24.34	40.00	15.66
2	96.930	16.75	2.05	6.45	25.25	43.50	18.25
3	250.190	23.83	3.50	2.18	29.51	46.00	16.49
4	378.230	17.19	4.60	8.76	30.55	46.00	15.45
5	532.460	19.64	7.00	3.60	30.24	46.00	15.76
6	627.520	21.15	6.31	2.92	30.39	46.00	15.61
7	773.990	24.21	6.80	1.04	32.04	46.00	13.96

Remarks: 1. Emission Level= Antenna Factor + Cable Loss + Reading.
 2. The emission levels that are 20dB below the official limit are not reported.



AUDIX Corp. EMC Laboratory
 No.53-11, Tin-fu Tsun, Lin-kou Hsiang, Taipei
 County, Taiwan R.O.C. Post Code:24443
 Tel:+886-2-26092133 Fax:+886-2-26099303
 Email:ttmc@ttmc.com.tw

Data: 9 File: D:\Test&Photo\2006 DATA\EM952510A Radiated\15C\RX\TX2442.EMI (10) Date: 2006-11-08

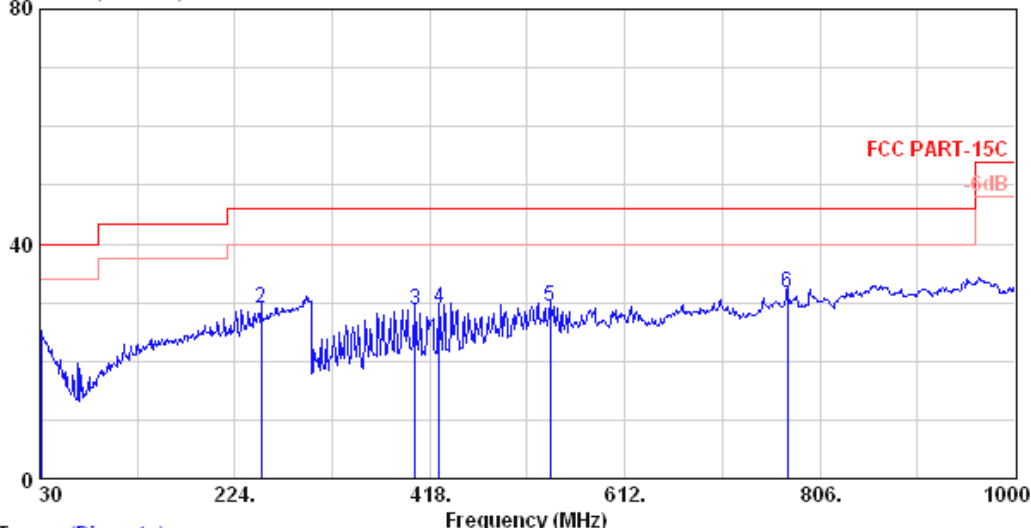

Trace: (Discrete)

Site no. : A/C Chamber Data no. : 9
 Dis. / Ant. : 3m VBA6106A/UHALP9108A Ant. pol. : VERTICAL
 Limit : FCC PART-15C
 Env. / Ins. : 8593EM 25°C/63% Engineer : Alvin_Yang
 EUT : Wireless Speaker M/N:ACC97WK-R
 Power Rating : 120Vac/60Hz
 Test Mode : TX2442.240MHz

	Ant.	Cable	Emission		Limits	Margin	Remark
Freq. (MHz)	Factor (dB/m)	Loss (dB)	Reading (dBμV)	Level (dBμV/m)	(dBμV/m)	(dB)	
1	30.970	24.81	1.10	-1.76	24.15	40.00	15.85
2	250.190	23.83	3.50	1.60	28.93	46.00	17.07
3	403.450	17.54	4.90	6.33	28.76	46.00	17.24
4	427.700	17.21	5.15	6.61	28.97	46.00	17.03
5	537.310	19.41	7.10	2.71	29.22	46.00	16.78
6	773.990	24.21	6.80	0.59	31.59	46.00	14.41

Remarks: 1. Emission Level= Antenna Factor + Cable Loss + Reading.
 2. The emission levels that are 20dB below the official limit are not reported.



AUDIX Corp. EMC Laboratory
 No.53-11, Tin-fu Tsun, Lin-kou Hsiang, Taipei
 County, Taiwan R.O.C. Post Code:24443
 Tel:+886-2-26092133 Fax:+886-2-26099303
 Email:ttemc@ttemc.com.tw

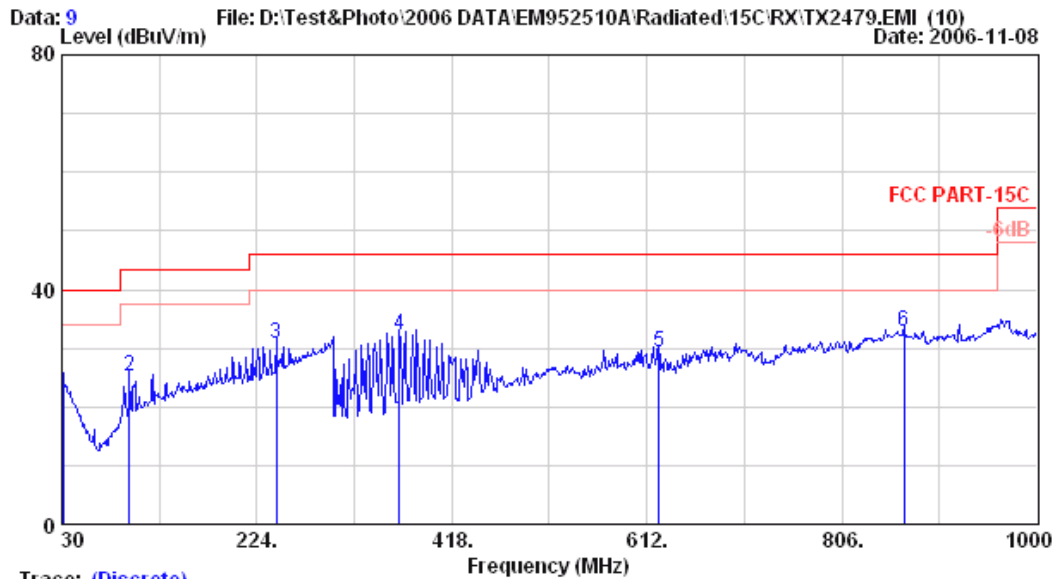

Trace: (Discrete)

Site no.	: A/C Chamber	Data no.	: 9
Dis. / Ant.	: 3m VBA6106A/UHALP9108A	Ant. pol.	: HORIZONTAL
Limit	: FCC PART-15C		
Env. / Ins.	: 8593EM 25+C/63%	Engineer	: Alvin_Yang
EUT	: Wireless Speaker M/N:ACC97WK-R		
Power Rating	: 120Vac/60Hz		
Test Mode	: TX2479.104MHz		

	Ant. Factor	Cable Loss	Reading	Emission Level	Limits	Margin	Remark
Freq. (MHz)	(dB/m)	(dB)	(dBµV)	(dBµV/m)	(dBµV/m)	(dB)	
1	30.970	24.81	1.10	-1.06	24.85	40.00	15.15
2	96.930	16.75	2.05	6.34	25.14	43.50	18.36
3	243.400	23.29	3.40	4.07	30.76	46.00	15.24
4	365.620	16.65	4.50	11.02	32.17	46.00	13.83
5	623.640	21.32	6.20	1.93	29.45	46.00	16.55
6	868.080	25.89	7.20	-0.22	32.87	46.00	13.13

Remarks: 1. Emission Level= Antenna Factor + Cable Loss + Reading.
 2. The emission levels that are 20dB below the official limit are not reported.



AUDIX Corp. EMC Laboratory
 No.53-11, Tin-fu Tsun, Lin-kou Hsiang, Taipei
 County, Taiwan R.O.C. Post Code:24443
 Tel:+886-2-26092133 Fax:+886-2-26099303
 Email:ttmc@ttmc.com.tw

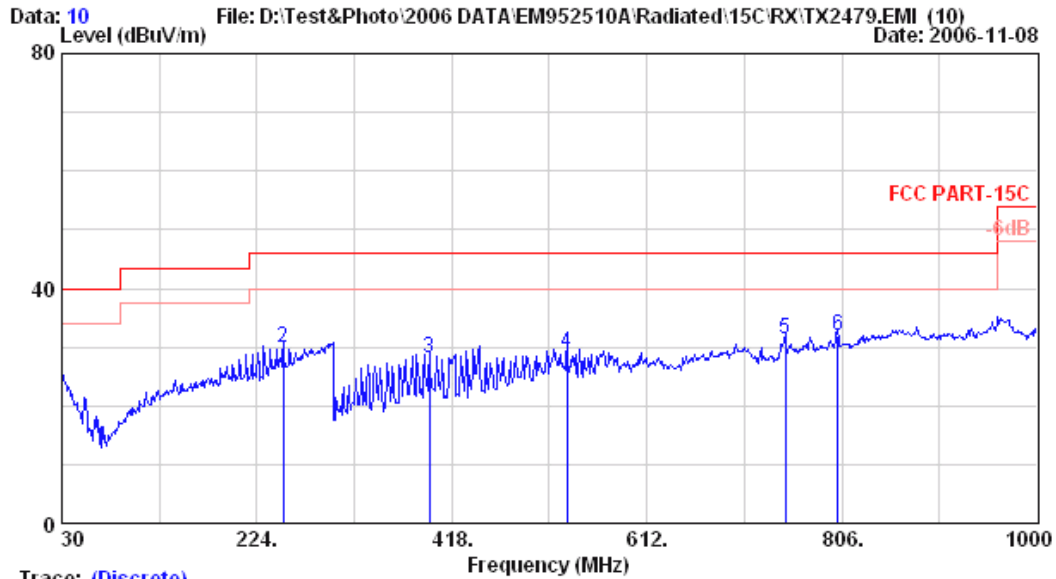

Trace: (Discrete)

Site no.	: A/C Chamber	Data no.	: 10
Dis. / Ant.	: 3m VBA6106A/UHALP9108A	Ant. pol.	: VERTICAL
Limit	: FCC PART-15C		
Env. / Ins.	: 8593EM 25°C/63%	Engineer	: Alvin_Yang
EUT	: Wireless Speaker M/N:ACC97WK-R		
Power Rating	: 120Vac/60Hz		
Test Mode	: TX2479.104MHz		

	Ant. Factor	Cable Loss	Reading	Emission Level	Limits	Margin	Remark
Freq. (MHz)	(dB/m)	(dB)	(dBuV)	(dBuV/m)	(dBuV/m)	(dB)	
1	30.000	24.86	1.10	-1.61	24.35	40.00	15.65
2	250.190	23.83	3.50	2.60	29.93	46.00	16.07
3	395.690	17.60	4.71	5.92	28.23	46.00	17.77
4	532.460	19.64	7.00	2.25	28.89	46.00	17.11
5	749.740	23.25	6.70	1.29	31.24	46.00	14.76
6	802.120	24.17	6.90	0.73	31.80	46.00	14.20

Remarks: 1. Emission Level= Antenna Factor + Cable Loss + Reading.
 2. The emission levels that are 20dB below the official limit are not reported.



AUDIX Corp. EMC Laboratory
 No.53-11, Tin-fu Tsun, Lin-kou Hsiang, Taipei
 County, Taiwan R.O.C. Post Code:24443
 Tel:+886-2-26092133 Fax:+886-2-26099303
 Email:ttemc@ttemc.com.tw

Data: 10 File: D:\Test&Photo\2006 DATA\EM952510A Radiated\15C\RX\RX2442.EMI (10) Date: 2006-11-08

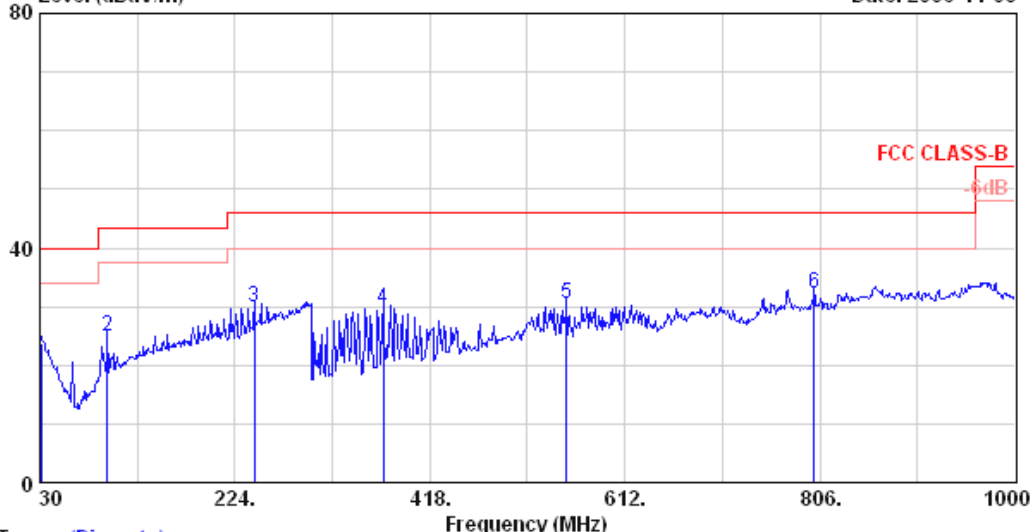

Trace: (Discrete)

Site no.	: A/C Chamber	Data no.	: 10
Dis. / Ant.	: 3m VBA6106A/UHALP9108A	Ant. pol.	: HORIZONTAL
Limit	: FCC CLASS-B		
Env. / Ins.	: 8593EM 25°C/63%	Engineer	: Alvin_Yang
EUT	: Wireless Speaker	M/N:	ACC97WK-R
Power Rating	: 120Vac/60Hz		
Test Mode	: RX2442.240MHz		

	Freq. (MHz)	Ant. Factor (dB/m)	Cable Loss (dB)	Reading (dBuV)	Emission Level (dBuV/m)	Limits (dBuV/m)	Margin (dB)	Remark
1	30.970	24.81	1.10	-2.04	23.87	40.00	16.13	
2	96.930	16.75	2.05	6.11	24.91	43.50	18.59	
3	243.400	23.29	3.40	3.29	29.98	46.00	16.02	
4	371.440	17.08	4.60	7.83	29.51	46.00	16.49	
5	553.800	19.40	6.80	4.19	30.39	46.00	15.61	
6	800.180	24.14	6.90	1.11	32.14	46.00	13.86	

Remarks: 1. Emission Level= Antenna Factor + Cable Loss + Reading.
 2. The emission levels that are 20dB below the official limit are not reported.



AUDIX Corp. EMC Laboratory
 No.53-11, Tin-fu Tsun, Lin-kou Hsiang, Taipei
 County, Taiwan R.O.C. Post Code:24443
 Tel:+886-2-26092133 Fax:+886-2-26099303
 Email:ttemc@ttemc.com.tw

Data: 9 File: D:\Test&Photo\2006 DATA\EM952510A Radiated\15C\RX\RX2442.EMI (10) Date: 2006-11-08

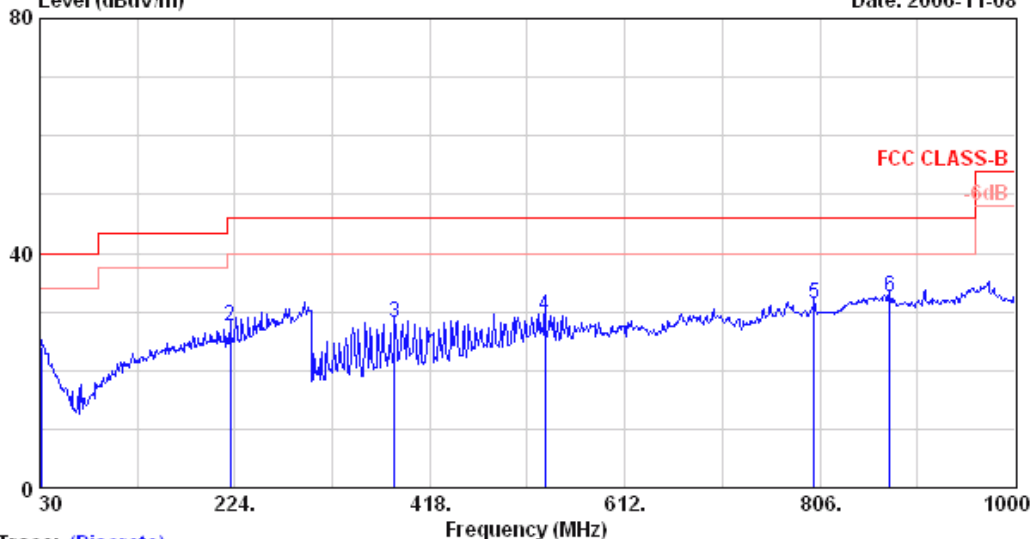

Trace: (Discrete)

Site no. : A/C Chamber Data no. : 9
 Dis. / Ant. : 3m VBA6106A/UHALP9108A Ant. pol. : VERTICAL
 Limit : FCC CLASS-B
 Env. / Ins. : 8593EM 25°C/63% Engineer : Alvin_Yang
 EUT : Wireless Speaker M/N:ACC97WK-R
 Power Rating : 120Vac/60Hz
 Test Mode : RX2442.240MHz

	Ant.	Cable	Emission				
Freq.	Factor	Loss	Reading	Level	Limits	Margin	Remark
(MHz)	(dB/m)	(dB)	(dBµV)	(dBµV/m)	(dBµV/m)	(dB)	
1	30.970	24.81	1.10	-1.76	24.15	40.00	15.85
2	219.150	21.91	3.21	2.34	27.46	46.00	18.54
3	383.080	17.33	4.62	6.21	28.17	46.00	17.83
4	532.460	19.64	7.00	2.68	29.32	46.00	16.68
5	800.180	24.14	6.90	0.24	31.27	46.00	14.73
6	875.840	25.35	7.30	-0.13	32.52	46.00	13.48

Remarks: 1. Emission Level= Antenna Factor + Cable Loss + Reading.
 2. The emission levels that are 20dB below the official limit are not reported.

3.6.2. Above 1GHz Frequency Range Measurement Results

Date of Test : Nov. 08, 2006 Temperature : 25
 EUT : Wireless Speaker (Receiver) Humidity : 63%
 Test Mode : Transmitting Mode, Frequency: 2403.328MHz (CH0) Test Voltage : AC 120V/60Hz

	Emission Frequency MHz	Antenna Factor dB/m	Cable Loss dB μ V	Meter Reading Horizontal dB μ V/m	Emission Level Horizontal dB μ V/m	Limits dB	Margin
Peak	1754.320	26.70	7.15	14.39	48.24	74.00	25.76
	1863.520	27.20	6.57	14.24	48.01	74.00	25.99
Average	1754.320	26.70	7.15	6.39	40.24	54.00	13.76
	1863.520	27.20	6.57	6.24	40.01	54.00	13.99
	Emission Frequency MHz	Antenna Factor dB/m	Cable Loss dB μ V	Meter Reading Vertical dB μ V/m	Emission Level Vertical dB μ V/m	Limits dB	Margin
Peak	1645.120	26.17	6.45	15.51	48.13	74.00	25.87
	1776.160	26.82	7.04	14.04	47.90	74.00	26.10
Average	1645.120	26.17	6.45	7.51	40.13	54.00	13.87
	1776.160	26.82	7.04	6.04	39.90	54.00	14.10

Remark : 1. Emission Level = Antenna Factor + Cable Loss + Meter Reading.
 2. Measurement was up to 25GHz, but the emissions level were too low against the official limit and not report.

Date of Test : Nov. 08, 2006 Temperature : 25
 EUT : Wireless Speaker (Receiver) Humidity : 63%
 Test Mode : Transmitting Mode, Frequency: 2442.240MHz (CH19) Test Voltage : AC 120V/60Hz

	Emission Frequency MHz	Antenna Factor dB/m	Cable Loss dB μ V	Meter Reading Horizontal dB μ V/m	Emission Level Horizontal dB μ V/m	Limits dB	Margin
Peak	1734.160	26.60	7.07	13.06	46.73	74.00	27.27
	1871.920	27.25	6.53	13.64	47.42	74.00	26.58
Average	1734.160	26.60	7.07	5.06	38.73	54.00	15.27
	1871.920	27.25	6.53	5.64	39.42	54.00	14.58

	Emission Frequency MHz	Antenna Factor dB/m	Cable Loss dB μ V	Meter Reading Vertical dB μ V/m	Emission Level Vertical dB μ V/m	Limits dB	Margin
Peak	1334.320	25.34	4.94	16.80	47.08	74.00	26.92
	1767.760	26.77	7.09	13.68	47.54	74.00	26.46
Average	1334.320	25.34	4.94	8.80	39.08	54.00	14.92
	1767.760	26.77	7.09	5.68	39.54	54.00	14.46

Remark : 1. Emission Level = Antenna Factor + Cable Loss + Meter Reading.
 2. Measurement was up to 25GHz, but the emissions level were too low against the official limit and not report.

Date of Test : Nov. 08, 2006 Temperature : 25
 EUT : Wireless Speaker (Receiver) Humidity : 63%
 Test Mode : Transmitting Mode, Frequency: 2479.104MHz (CH37) Test Voltage : AC 120V/60Hz

	Emission Frequency MHz	Antenna Factor dB/m	Cable Loss dB μ V	Meter Reading Horizontal dB μ V/m	Emission Level Horizontal dB μ V/m	Limits dB	Margin
Peak	1737.520	26.62	7.07	12.82	46.51	74.00	27.49
	1843.360	27.13	6.67	13.03	46.83	74.00	27.17
Average	1737.520	26.62	7.07	4.82	38.51	54.00	15.49
	1843.360	27.13	6.67	5.03	38.83	54.00	15.17
	Emission Frequency MHz	Antenna Factor dB/m	Cable Loss dB μ V	Meter Reading Vertical dB μ V/m	Emission Level Vertical dB μ V/m	Limits dB	Margin
Peak	1653.520	26.22	6.52	15.23	47.97	74.00	26.03
	1759.360	26.72	7.12	14.57	48.41	74.00	25.59
Average	1653.520	26.22	6.52	7.23	39.97	54.00	14.03
	1759.360	26.72	7.12	6.57	40.41	54.00	13.59

Remark : 1. Emission Level = Antenna Factor + Cable Loss + Meter Reading.
 2. Measurement was up to 25GHz, but the emissions level were too low against the official limit and not report.

Date of Test : Nov. 08, 2006 Temperature : 25
 EUT : Wireless Speaker (Receiver) Humidity : 63%
 Test Mode : Receiving Mode, Frequency: 2442.240MHz (CH19) Test Voltage : AC 120V/60Hz

	Emission Frequency MHz	Antenna Factor dB/m	Cable Loss dBμV	Meter Reading Horizontal dBμV/m	Emission Level Horizontal dBμV/m	Limits dB	Margin
Peak	1750.960	26.70	7.16	13.45	47.31	74.00	26.69
	1860.160	27.20	6.59	13.25	47.04	74.00	26.96
Average	1750.960	26.70	7.16	5.45	39.31	54.00	14.69
	1860.160	27.20	6.59	5.25	39.04	54.00	14.96

	Emission Frequency MHz	Antenna Factor dB/m	Cable Loss dBμV	Meter Reading Vertical dBμV/m	Emission Level Vertical dBμV/m	Limits dB	Margin
Peak	1737.520	26.62	7.07	12.82	46.51	74.00	27.49
	1885.360	27.30	6.45	12.69	46.44	74.00	27.56
Average	1737.520	26.62	7.07	4.82	38.51	54.00	15.49
	1885.360	27.30	6.45	4.69	38.44	54.00	15.56

Remark : 1. Emission Level = Antenna Factor + Cable Loss + Meter Reading.
 2. Measurement was up to 25GHz, but the emissions level were too low against the official limit and not report.

3.6.3. Restricted Bands Measurement Results

Date of Test : Nov. 08, 2006 Temperature : 25
 EUT : Wireless Speaker (Receiver) Humidity : 63%
 Test Mode : Transmitting Mode, Frequency: 2403.328MHz (CH0) Test Voltage : AC 120V/60Hz

	Emission Frequency MHz	Antenna Factor dB/m	Cable Loss dB μ V	Meter Reading Horizontal dB μ V/m	Emission Level Horizontal dB μ V/m	Limits dB	Margin
Peak *	2380.290	28.58	6.32	9.94	44.84	74.00	29.16
Average *	2390.000	28.59	6.34	-1.68	33.25	54.00	20.75

- Remark : 1. Emission Level = Antenna Factor + Cable Loss + Meter Reading.
 2. Low frequency section (spurious in the restricted band 2310-2390MHz).
 3. '*' The field strength of emission appearing within Part 15.205(a) shall not exceed the limits shown in section 15.209.



AUDIX Corp. EMC Laboratory
 No.53-11, Tin-fu Tsun, Lin-kou Hsiang, Taipei
 County, Taiwan R.O.C. Post Code 24443
 Tel:+886-2-26092133 Fax:+886-2-26099303
 Email:ttmc@ttmc.com.tw



AUDIX Corp. EMC Laboratory
 No.53-11, Tin-fu Tsun, Lin-kou Hsiang, Taipei
 County, Taiwan R.O.C. Post Code 24443
 Tel:+886-2-26092133 Fax:+886-2-26099303
 Email:ttmc@ttmc.com.tw

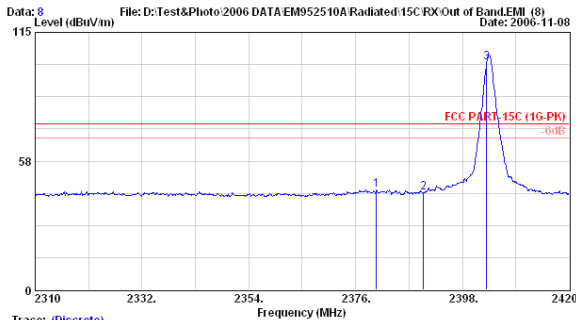

Trace: (Discrete)
 Site no. : A/C Chamber Data no. : 8
 Dis. / Ant. : 3m 3115 Ant. pol. : HORIZONTAL
 Limit : FCC PART-15C (16-PK)
 Env. / Ins. : 8593EM 25°C/63% Engineer : Alvin_Yang
 EUT : Wireless Speaker M/N:ACC97WK-R
 Power Rating : 120Vac/60Hz
 Test Mode : TX2479.104MHz

	Freq. (MHz)	Ant. Factor (dB/m)	Cable Loss (dB)	Reading (dB μ V)	Emission Level (dB μ V/m)	Limits (dB μ V/m)	Margin (dB)	Remark
1	2380.290	28.58	6.32	9.94	44.84	74.00	29.16	Peak
2	2390.000	28.59	6.34	8.31	43.25	74.00	30.75	Peak
3	2403.000	28.62	6.36	66.60	101.58	74.00	-27.58	Peak

Remarks: 1. Emission Level= Antenna Factor + Cable Loss + Reading.
 2. The emission levels that are 20dB below the official limit are not reported.

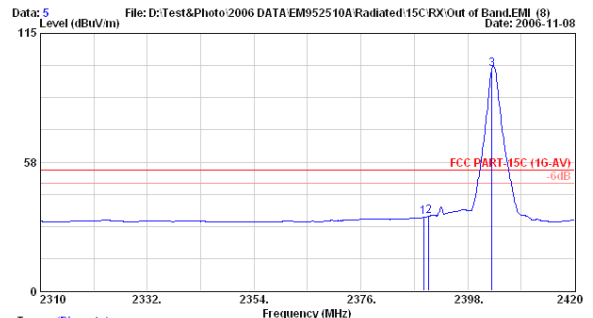

Trace: (Discrete)
 Site no. : A/C Chamber Data no. : 5
 Dis. / Ant. : 3m 3115 Ant. pol. : HORIZONTAL
 Limit : FCC PART-15C (16-AV)
 Env. / Ins. : 8593EM 25°C/63% Engineer : Alvin_Yang
 EUT : Wireless Speaker M/N:ACC97WK-R
 Power Rating : 120Vac/60Hz
 Test Mode : TX2403.328MHz

	Freq. (MHz)	Ant. Factor (dB/m)	Cable Loss (dB)	Reading (dB μ V)	Emission Level (dB μ V/m)	Limits (dB μ V/m)	Margin (dB)	Remark
1	2388.870	28.59	6.34	-2.23	32.70	54.00	21.30	Average
2	2390.000	28.59	6.34	-1.68	33.26	54.00	20.74	Average
3	2403.000	28.62	6.36	64.12	99.10	54.00	-45.10	Average

Remarks: 1. Emission Level= Antenna Factor + Cable Loss + Reading.
 2. The emission levels that are 20dB below the official limit are not reported.

Date of Test : Nov. 08, 2006 Temperature : 25

EUT : Wireless Speaker (Receiver) Humidity : 63%

Test Mode : Transmitting Mode, Frequency: 2403.328MHz (CH0) Test Voltage : AC 120V/60Hz

	Emission Frequency MHz	Antenna Factor dB/m	Cable Loss dBμV	Meter Reading Vertical dBμV/m	Emission Level Vertical dBμV/m	Limits dB	Margin
Peak *	2390.000	28.59	6.34	13.35	48.28	74.00	25.72
Average *	2378.420	28.58	6.32	1.22	36.12	54.00	17.88

- Remark : 1. Emission Level = Antenna Factor + Cable Loss + Meter Reading.
 2. Low frequency section (spurious in the restricted band 2310-2390MHz).
 3. '*' The field strength of emission appearing within Part 15.205(a) shall not exceed the limits shown in section 15.209.



AUDIX Corp. EMC Laboratory
 No.53-11, Tin-fu Tsun, Lin-kou Hsiang, Taipei
 County, Taiwan R.O.C. Post Code:24443
 Tel:+886-2-26092133 Fax:+886-2-26099303
 Email:ttmc@ttmc.com.tw



AUDIX Corp. EMC Laboratory
 No.53-11, Tin-fu Tsun, Lin-kou Hsiang, Taipei
 County, Taiwan R.O.C. Post Code:24443
 Tel:+886-2-26092133 Fax:+886-2-26099303
 Email:ttmc@ttmc.com.tw

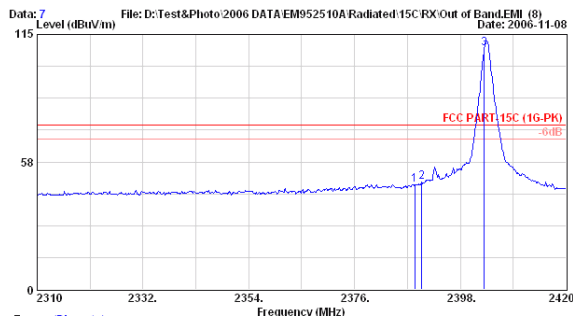

Trace: (Discrete)
 Site no. : A/C Chamber Data no. : 7
 Dis. / Ant. : 3m 3115 Ant. pol. : VERTICAL
 Limit : FCC PART-15C (1G-PK)
 Env. / Ins. : 8593EM 25°C/63% Engineer : Alvin_Yang
 EUT : Wireless Speaker M/N:ACC97WK-R
 Power Rating : 120Vac/60Hz
 Test Mode : TX2479.104MHz

Freq. (MHz)	Ant. Factor (dB/m)	Cable Loss (dB)	Reading (dBμV)	Emission Level (dBμV/m)	Limits (dBμV/m)	Margin (dB)	Remark
1 2388.540	28.59	6.34	12.45	47.38	74.00	26.62	Peak
2 2390.000	28.59	6.34	13.35	48.29	74.00	25.71	Peak
3 2403.000	28.62	6.36	73.72	108.70	74.00	-34.70	Peak

Remarks: 1. Emission Level= Antenna Factor + Cable Loss + Reading.
 2. The emission levels that are 20dB below the official limit are not reported.

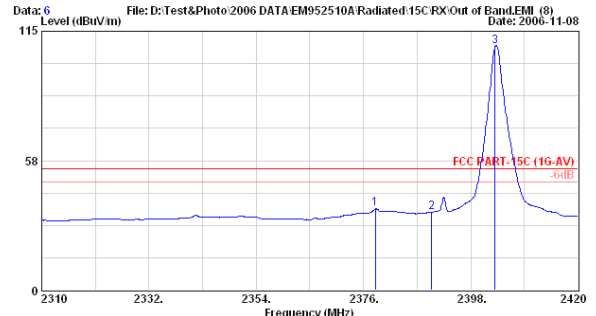

Trace: (Discrete)
 Site no. : A/C Chamber Data no. : 6
 Dis. / Ant. : 3m 3115 Ant. pol. : VERTICAL
 Limit : FCC PART-15C (1G-AV)
 Env. / Ins. : 8593EM 25°C/63% Engineer : Alvin_Yang
 EUT : Wireless Speaker M/N:ACC97WK-R
 Power Rating : 120Vac/60Hz
 Test Mode : TX2479.104MHz

Freq. (MHz)	Ant. Factor (dB/m)	Cable Loss (dB)	Reading (dBμV)	Emission Level (dBμV/m)	Limits (dBμV/m)	Margin (dB)	Remark
1 2378.420	28.58	6.32	1.22	36.12	54.00	17.88	Average
2 2390.000	28.59	6.34	-0.35	34.59	54.00	19.41	Average
3 2403.000	28.62	6.36	73.08	108.06	54.00	-54.06	Average

Remarks: 1. Emission Level= Antenna Factor + Cable Loss + Reading.
 2. The emission levels that are 20dB below the official limit are not reported.

Date of Test : Nov. 08, 2006 Temperature : 25
 EUT : Wireless Speaker (Receiver) Humidity : 63%
 Test Mode : Transmitting Mode, Frequency: 2479.104MHz (CH37) Test Voltage : AC 120V/60Hz

	Emission Frequency MHz	Antenna Factor dB/m	Cable Loss dBμV	Meter Reading Horizontal dBμV/m	Emission Level Horizontal dBμV/m	Limits dB	Margin
Peak *	2483.600	28.77	6.45	16.45	51.67	74.00	22.33
Average *	2483.600	28.77	6.45	8.35	43.57	54.00	10.43

- Remark : 1. Emission Level = Antenna Factor + Cable Loss + Meter Reading.
 2. Low frequency section (spurious in the restricted band 2483.5-2500MHz).
 3. '*' The field strength of emission appearing within Part 15.205(a) shall not exceed the limits shown in section 15.209.



AUDIX Corp. EMC Laboratory
 No.53-11, Tin-Fu Tsun, Lin-kou Hsiang, Taipei
 County, Taiwan R.O.C. Post Code:24443
 Tel:+886-2-26092133 Fax:+886-2-26099303
 Email:ttenc@ttenc.com.tw



AUDIX Corp. EMC Laboratory
 No.53-11, Tin-Fu Tsun, Lin-kou Hsiang, Taipei
 County, Taiwan R.O.C. Post Code:24443
 Tel:+886-2-26092133 Fax:+886-2-26099303
 Email:ttenc@ttenc.com.tw

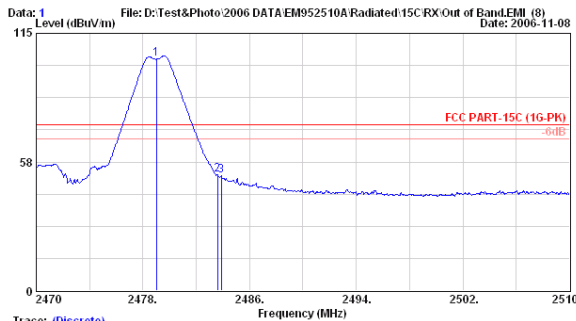

Trace: (Discrete)
 Site no. : A/C Chamber Data no. : 1
 Dis. / Ant. : 3m 3115 Ant. pol. : HORIZONTAL
 Limit : FCC PART-15C (1G-PK)
 Env. / Ins. : 8593EM 25°C/63% Engineer : Alvin_Yang
 EUT : Wireless Speaker M/N:ACC97WK-R
 Power Rating : 120Vac/60Hz
 Test Mode : TX2479.104MHz

Trace	Freq. (MHz)	Ant. Factor (dB/m)	Cable Loss (dB)	Reading (dBμV)	Emission Level (dBμV/m)	Limits (dBμV/m)	Margin (dB)	Remark
1	2479.000	28.76	6.44	68.27	103.47	74.00	-29.47	Peak
2	2483.600	28.77	6.45	16.45	51.67	74.00	22.33	Peak
3	2483.880	28.77	6.45	16.18	51.40	74.00	22.60	Peak

Remarks: 1. Emission Level= Antenna Factor + Cable Loss + Reading.
 2. The emission levels that are 20dB below the official limit are not reported.

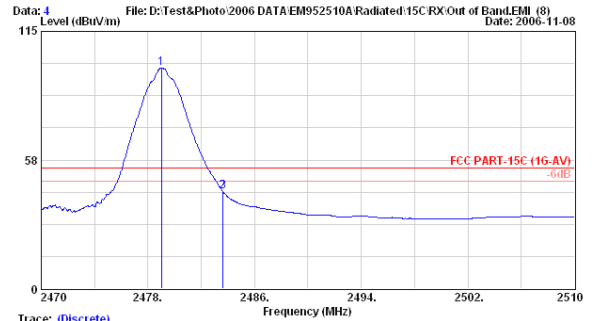

Trace: (Discrete)
 Site no. : A/C Chamber Data no. : 4
 Dis. / Ant. : 3m 3115 Ant. pol. : HORIZONTAL
 Limit : FCC PART-15C (1G-AV)
 Env. / Ins. : 8593EM 25°C/63% Engineer : Alvin_Yang
 EUT : Wireless Speaker M/N:ACC97WK-R
 Power Rating : 120Vac/60Hz
 Test Mode : TX2479.104MHz

Trace	Freq. (MHz)	Ant. Factor (dB/m)	Cable Loss (dB)	Reading (dBμV)	Emission Level (dBμV/m)	Limits (dBμV/m)	Margin (dB)	Remark
1	2479.000	28.76	6.44	63.36	98.56	54.00	-44.56	Average
2	2483.600	28.77	6.45	8.35	43.57	54.00	10.43	Average
3	2483.640	28.77	6.45	8.09	43.31	54.00	10.69	Average

Remarks: 1. Emission Level= Antenna Factor + Cable Loss + Reading.
 2. The emission levels that are 20dB below the official limit are not reported.

Date of Test : Nov. 08, 2006 Temperature : 25

EUT : Wireless Speaker (Receiver) Humidity : 63%

Test Mode : Transmitting Mode, Frequency: 2479.104MHz (CH37) Test Voltage : AC 120V/60Hz

	Emission Frequency MHz	Antenna Factor dB/m	Cable Loss dB μ V	Meter Reading Vertical dB μ V/m	Emission Level Vertical dB μ V/m	Limits dB	Margin
Peak *	2483.880	28.77	6.45	21.78	57.00	74.00	17.00
Average *	2483.600	28.77	6.45	13.92	49.14	54.00	4.86

- Remark : 1. Emission Level = Antenna Factor + Cable Loss + Meter Reading.
 2. Low frequency section (spurious in the restricted band 2483.5-2500MHz).
 3. '*' The field strength of emission appearing within Part 15.205(a) shall not exceed the limits shown in section 15.209.



AUDIX Corp. EMC Laboratory
 No.53-11, Tin-fu Tsun, Lin-kou Hsiang, Taipei County, Taiwan R.O.C. Post Code:24443
 Tel:+886-2-26092133 Fax:+886-2-26099303
 Email:ttenc@ttenc.com.tw



AUDIX Corp. EMC Laboratory
 No.53-11, Tin-fu Tsun, Lin-kou Hsiang, Taipei County, Taiwan R.O.C. Post Code:24443
 Tel:+886-2-26092133 Fax:+886-2-26099303
 Email:ttenc@ttenc.com.tw

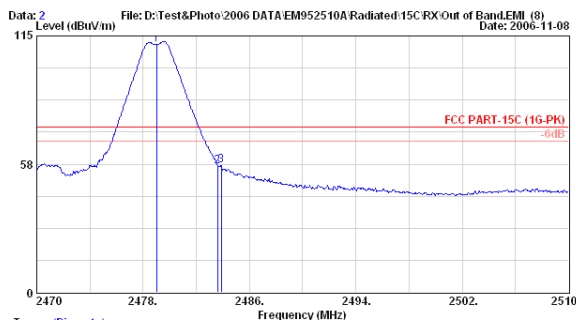

Trace: (Discrete)
 Site no. : A/C Chamber Data no. : 2
 Dis. / Ant. : 3m 3115 Ant. pol. : VERTICAL
 Limit : FCC PART-15C (1G-PK)
 Env. / Ins. : 8593EM 25°C/63% Engineer : Alvin_Yang
 EUT : Wireless Speaker M/N:ACC97WK-R
 Power Rating : 120Vac/60Hz
 Test Mode : TX2479.104MHz

	Freq. (MHz)	Ant. Factor (dB/m)	Cable Loss (dB)	Reading (dB μ V)	Emission Level (dB μ V/m)	Limits (dB μ V/m)	Margin (dB)	Remark
1	2479.000	28.76	6.44	75.88	111.08	74.00	-37.08	Peak
2	2483.600	28.77	6.45	21.32	56.54	74.00	17.46	Peak
3	2483.880	28.77	6.45	21.78	57.00	74.00	17.00	Peak

Remarks: 1. Emission Level= Antenna Factor + Cable Loss + Reading.
 2. The emission levels that are 20dB below the official limit are not reported.

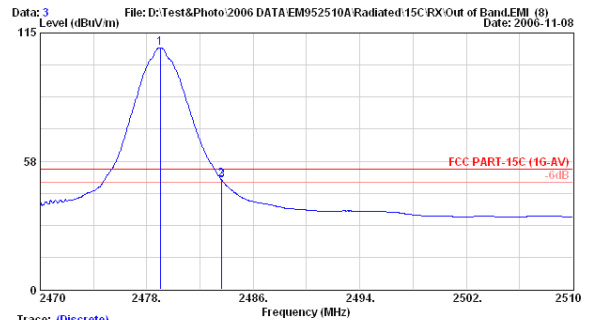

Trace: (Discrete)
 Site no. : A/C Chamber Data no. : 3
 Dis. / Ant. : 3m 3115 Ant. pol. : VERTICAL
 Limit : FCC PART-15C (1G-AV)
 Env. / Ins. : 8593EM 25°C/63% Engineer : Alvin_Yang
 EUT : Wireless Speaker M/N:ACC97WK-R
 Power Rating : 120Vac/60Hz
 Test Mode : TX2479.104MHz

	Freq. (MHz)	Ant. Factor (dB/m)	Cable Loss (dB)	Reading (dB μ V)	Emission Level (dB μ V/m)	Limits (dB μ V/m)	Margin (dB)	Remark
1	2479.000	28.76	6.44	73.20	108.40	54.00	-54.40	Average
2	2483.600	28.77	6.45	13.92	49.15	54.00	4.85	Average
3	2483.640	28.77	6.45	13.68	48.91	54.00	5.09	Average

Remarks: 1. Emission Level= Antenna Factor + Cable Loss + Reading.
 2. The emission levels that are 20dB below the official limit are not reported.

4. 20dB BANDWIDTH MEASUREMENT

4.1. Test Equipment

The following test equipment was used during the 20dB bandwidth measurement:

Item	Type	Manufacturer	Model No.	Serial No.	Last Cal.	Next Cal.
1.	Spectrum Monitor	Agilent	E4446A	US44300366	Aug. 11, 06'	Aug. 10. 07'

4.2. Block Diagram of Test Setup

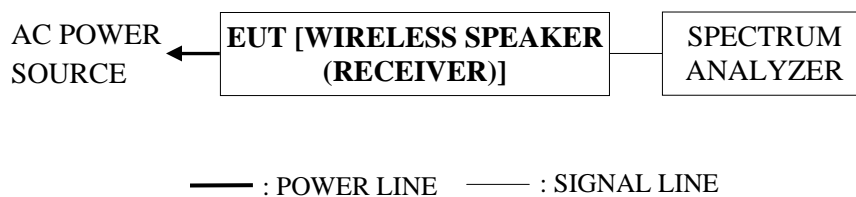

4.3. Specification Limits (§15.247(a)(1))

Alternatively, frequency hopping systems operating in the 2400-2483.5MHz band may have hopping channel carrier frequencies that are separated by 25kHz or two-thirds of the 20dB bandwidth of the hopping channel, whichever is greater.

4.4. Operating Condition of EUT

- 4.4.1. Setup the EUT and simulator as shown on 4.2.
- 4.4.2. Turn on the power of all equipment.
- 4.4.3. EUT [Wireless Speaker (Receiver)] was on transmitting frequency function during the testing.

4.5. Test Procedure

The transmitter output was connected to the spectrum analyzer. The bandwidth of the fundamental frequency was measure by spectrum analyzer with 100kHz RBW and 100kHz VBW. The 20dB bandwidth is defined as the total spectrum the power of which is higher than peak power minus 20dB.

4.6. Test Results

PASSED. All the test results are attached in next pages.

Test Date : Nov. 08, 2006 Temperature : 26 Humidity : 53 %

No.	Channel	Test Frequency	20dB Bandwidth	2/3 (20dB Bandwidth)
1.	0	2403.328MHz	1.97MHz	1.313MHz
2.	19	2442.240MHz	1.90MHz	1.267MHz
3.	37	2479.104MHz	1.88MHz	1.253MHz

The maximum two-thirds of the 20dB bandwidth shall be at maximum 1.287MHz.

4.6.1. Channel 0, Frequency: 2403.328MHz

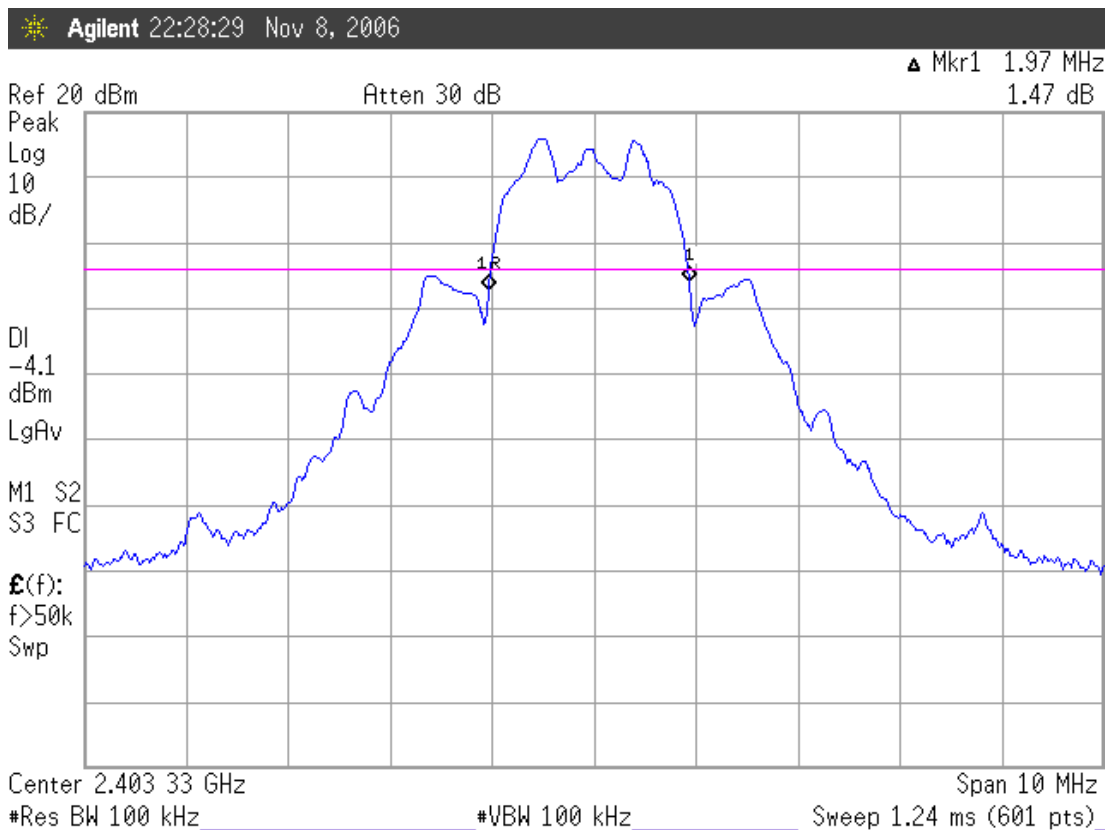

4.6.2. Channel 39, Frequency: 2442.240MHz

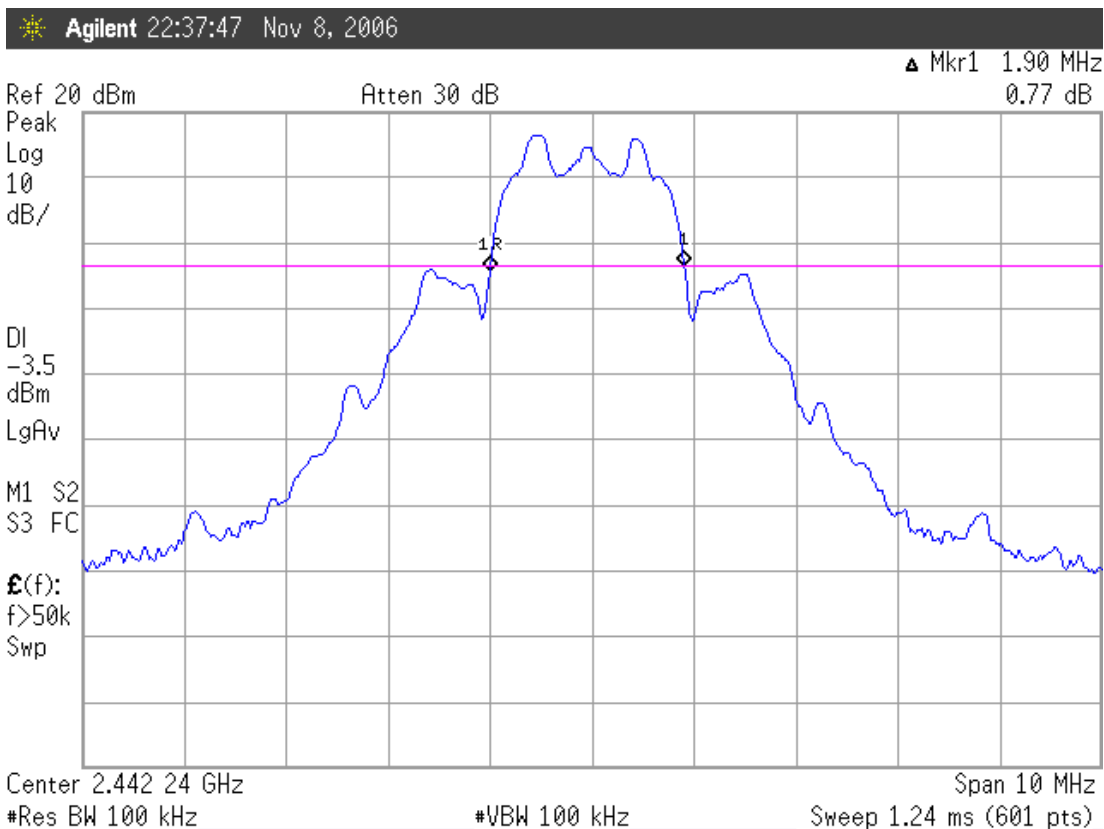

4.6.3. Channel 78, Frequency: 2479.104MHz

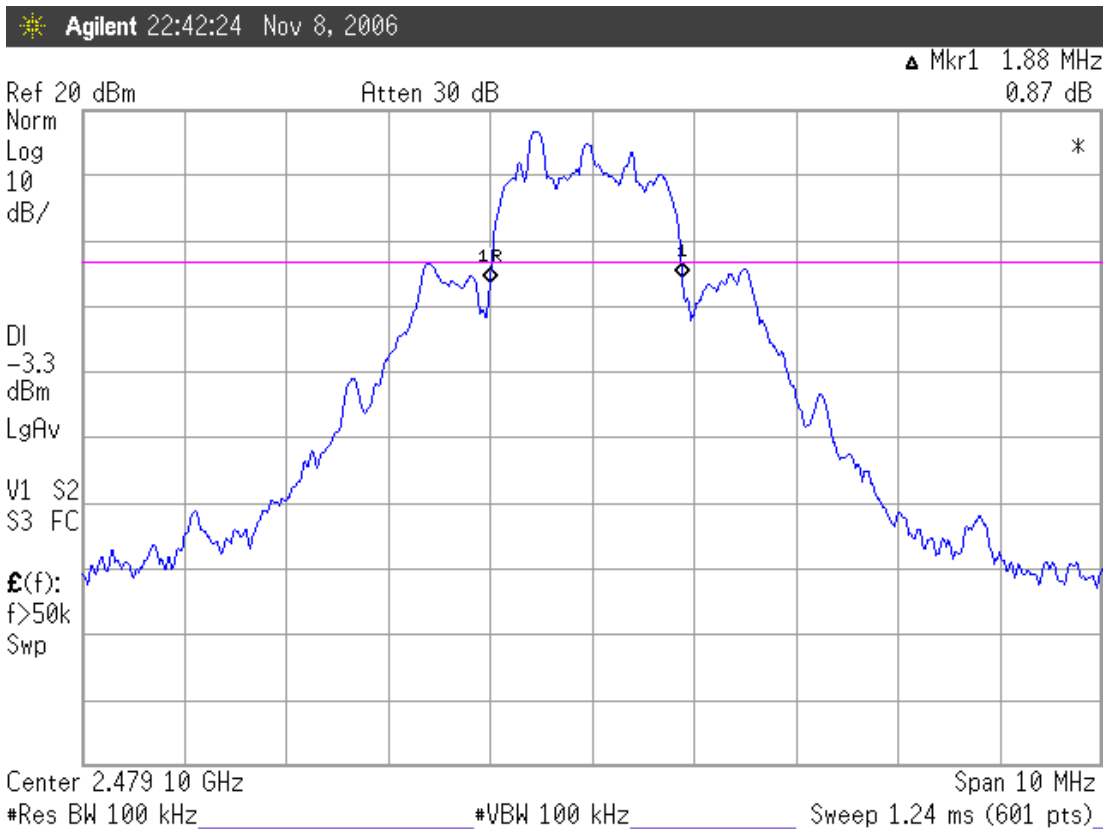

5. CARRIER FREQUENCY SEPARATION MEASUREMENT

5.1. Test Equipment

The following test equipment was used during the carrier frequency separation measurement:

Item	Type	Manufacturer	Model No.	Serial No.	Last Cal.	Next Cal.
1.	Spectrum Monitor	Agilent	E4446A	US44300366	Aug. 11, 06'	Aug. 10. 07'

5.2. Block Diagram of Test Setup

The same as section.4.2.

5.3. Specification Limits (§15.247(a)(1))

Alternatively, frequency hopping systems operating in the 2400-2483.5MHz band may have hopping channel carrier frequencies that are separated by 25kHz or two-thirds of the 20dB bandwidth of the hopping channel, whichever is greater.

5.4. Operating Condition of EUT

Same as carrier frequency separation measurement which was listed in section 4.4.

5.5. Test Procedure

The transmitter output was connected to the spectrum analyzer. The channel separation was measure by spectrum analyzer with 100kHz RBW and 100kHz VBW. The video bandwidth not to be smaller than resolution bandwidth, the peak was mark on adjacent bandwidth, the between of peak is carrier frequency separation.

5.6. Test Results

PASSED. All the test results are attached in next pages.

Test Date : Nov. 08, 2006 Temperature : 26 Humidity : 53 %

The minimum adjacent channel carrier frequency separation: 1.96MHz.

[Above values have met the requirement as specified in section 4.3: frequency hopping systems operating in the 2400-2483.5 MHz band may have hopping channel carrier frequencies that are separated by 25 kHz or two-thirds of the 20 dB bandwidth of the hopping channel, whichever is greater.]

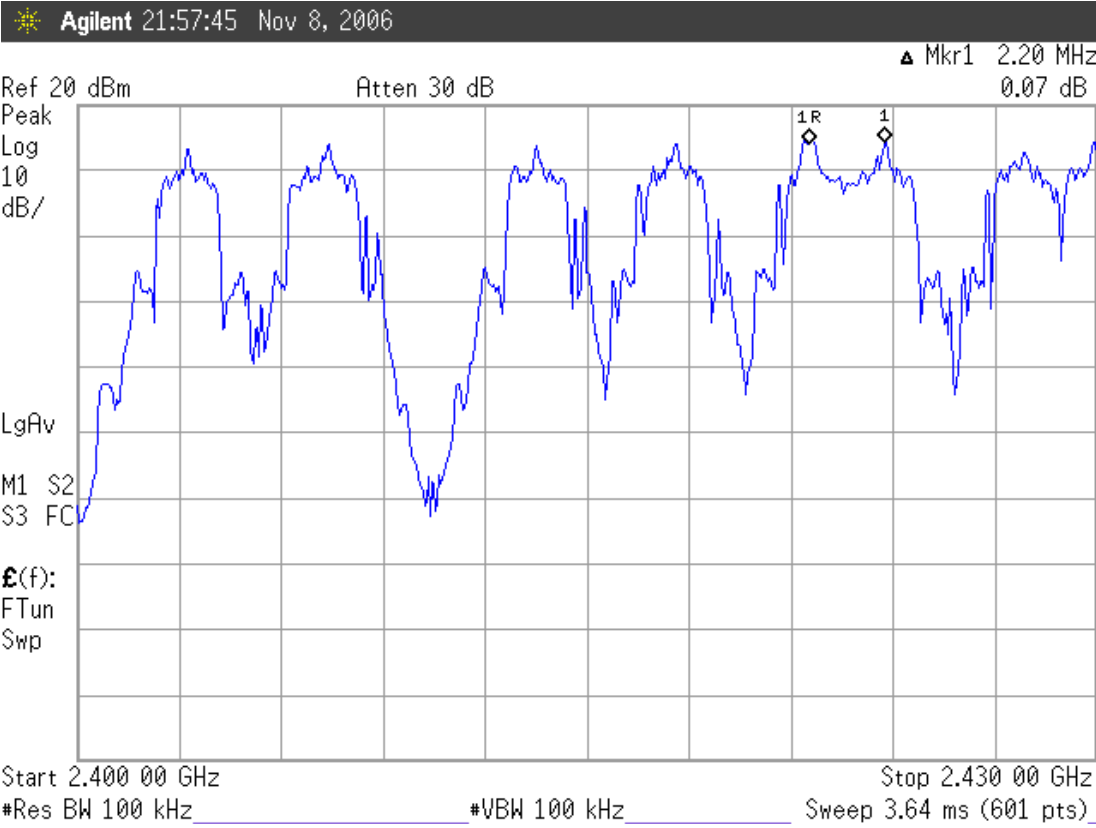
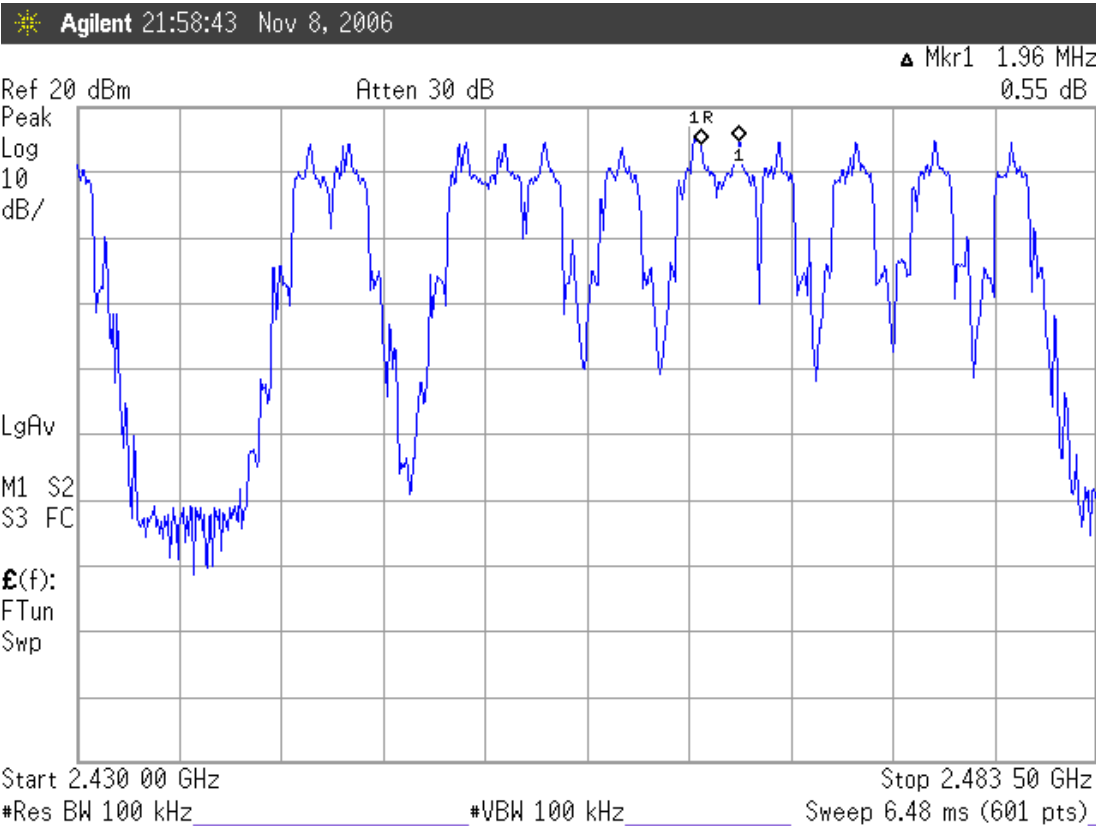

6. TIME OF OCCUPANCY MEASUREMENT

6.1. Test Equipment

The following test equipment was used during the time of occupancy measurement:

Item	Type	Manufacturer	Model No.	Serial No.	Last Cal.	Next Cal.
1.	Spectrum Monitor	Agilent	E4446A	US44300366	Aug. 11, 06'	Aug. 10. 07'

6.2. Block Diagram of Test Setup

The same as section.4.2.

6.3. Specification Limits (§15.247(a)(1)(iii))

Frequency hopping systems in the 2400-2483.5MHz shall use at least 15 non-overlapping channels. The average time of occupancy on any channel shall not be greater than 0.4 seconds within a period of 0.4 seconds multiplied by number of hopping channels employed.

6.4. Operating Condition of EUT

Same as carrier frequency separation measurement which was listed in section 4.4.

6.5. Test Procedure

The transmitter output was connected to the spectrum analyzer. The bandwidth of the fundamental frequency was measure by spectrum analyzer with 1MHz RBW and 1MHz VBW. $VBW \geq RBW$; Span=zero span.

Centered on a hopping channel sweep=as necessary to capture the entire dwell time per hopping channel ; Detector function=peak ; Trace=Max hold

6.6. Test Results

PASSED. All the test results are attached in next pages.

Test Date : Nov. 08, 2006 Temperature : 26 Humidity : 53 %

Duty cycle: 20 channels*0.4 seconds = 8 seconds

Test Frequency: 2403.328MHz

For per second of 9 channels appearance, the longest time of occupancy for each of 8 seconds is:

9 channels*8 seconds* 4.628ms = 333.216ms (<400ms)

Test Frequency: 2442.240MHz

For per second of 9 channels appearance, the longest time of occupancy for each of 8 seconds is:

9 channels*8 seconds* 4.606ms = 331.632ms (<400ms)

Test Frequency: 2479.104MHz

For per second of 9 channels appearance, the longest time of occupancy for each of 8 seconds is:

9 channels*8 seconds*4.606ms = 331.632ms (<400ms)

6.6.1. Channel 0, Test Frequency: 2403.328MHz

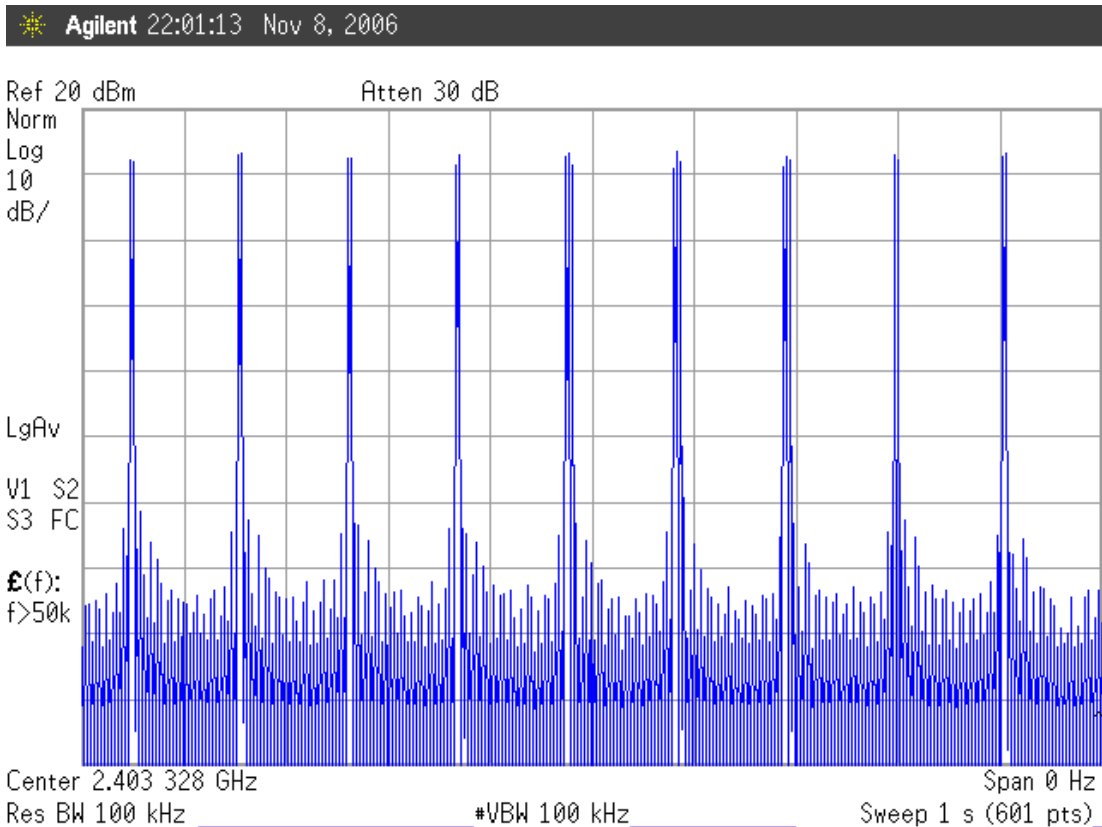
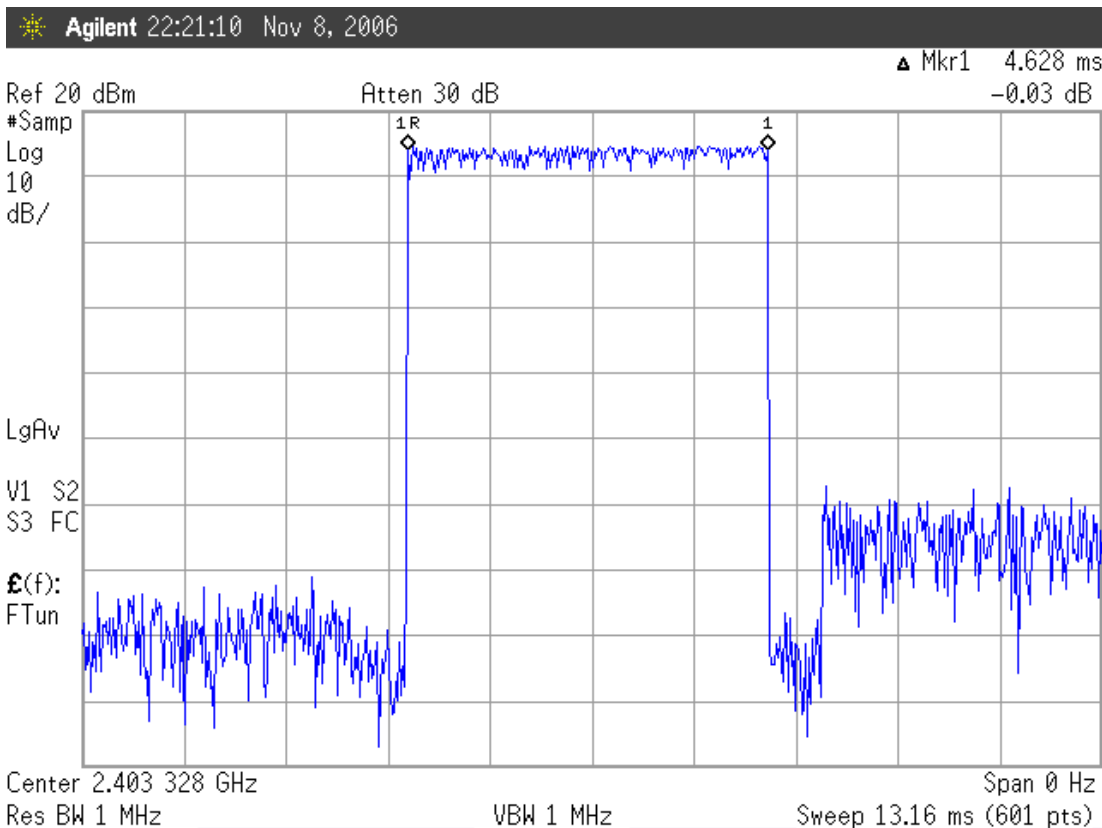

6.6.2. Channel 19, Test Frequency: 2442.240MHz

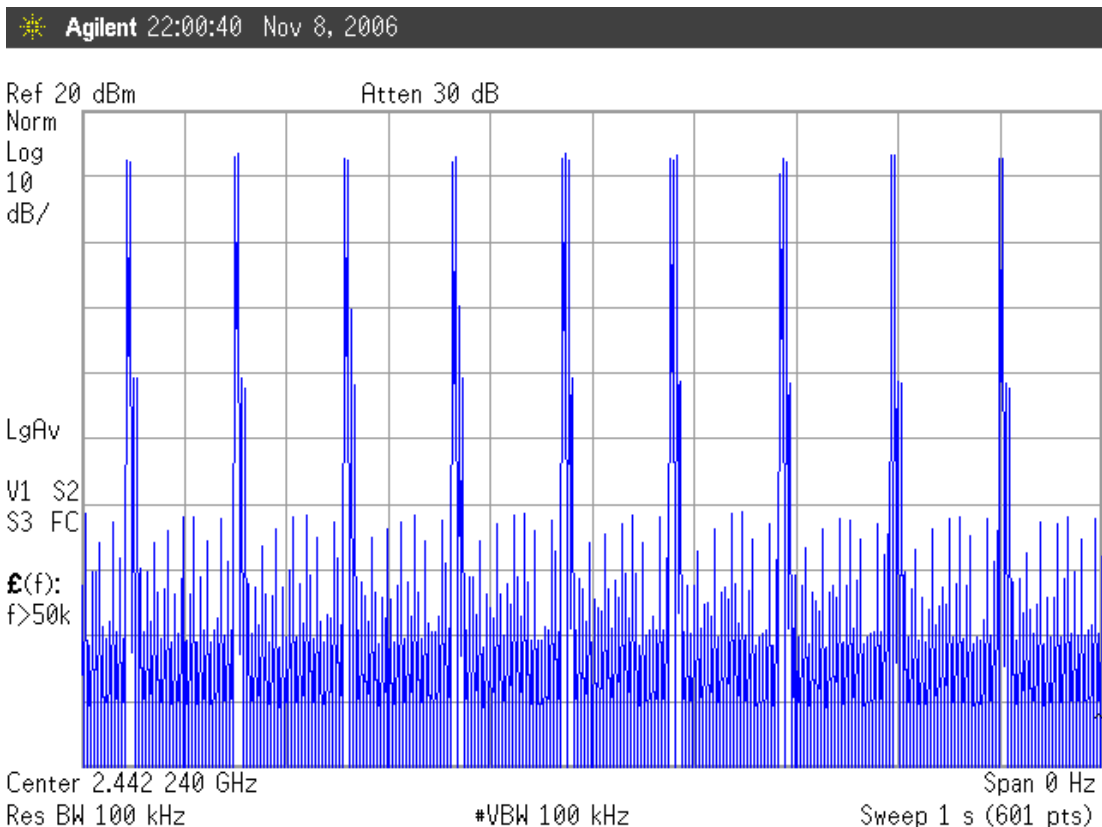
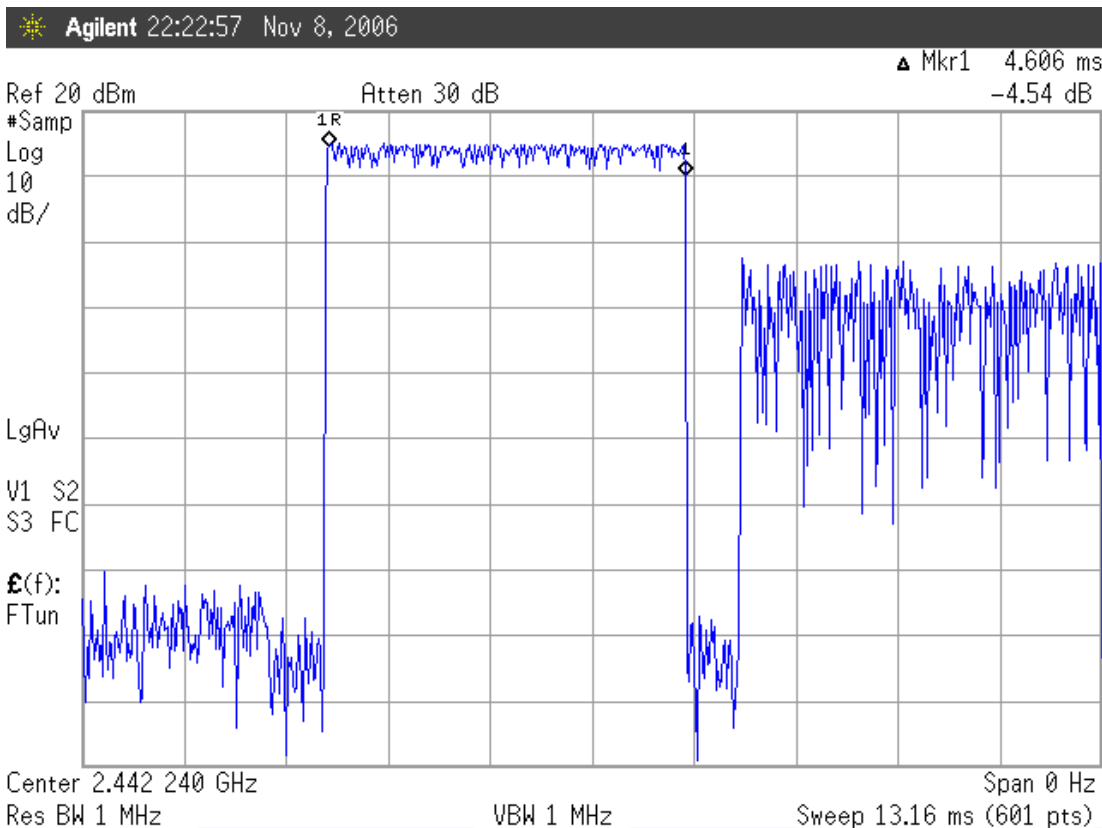

6.6.3. Channel 37, Test Frequency: 2479.104MHz

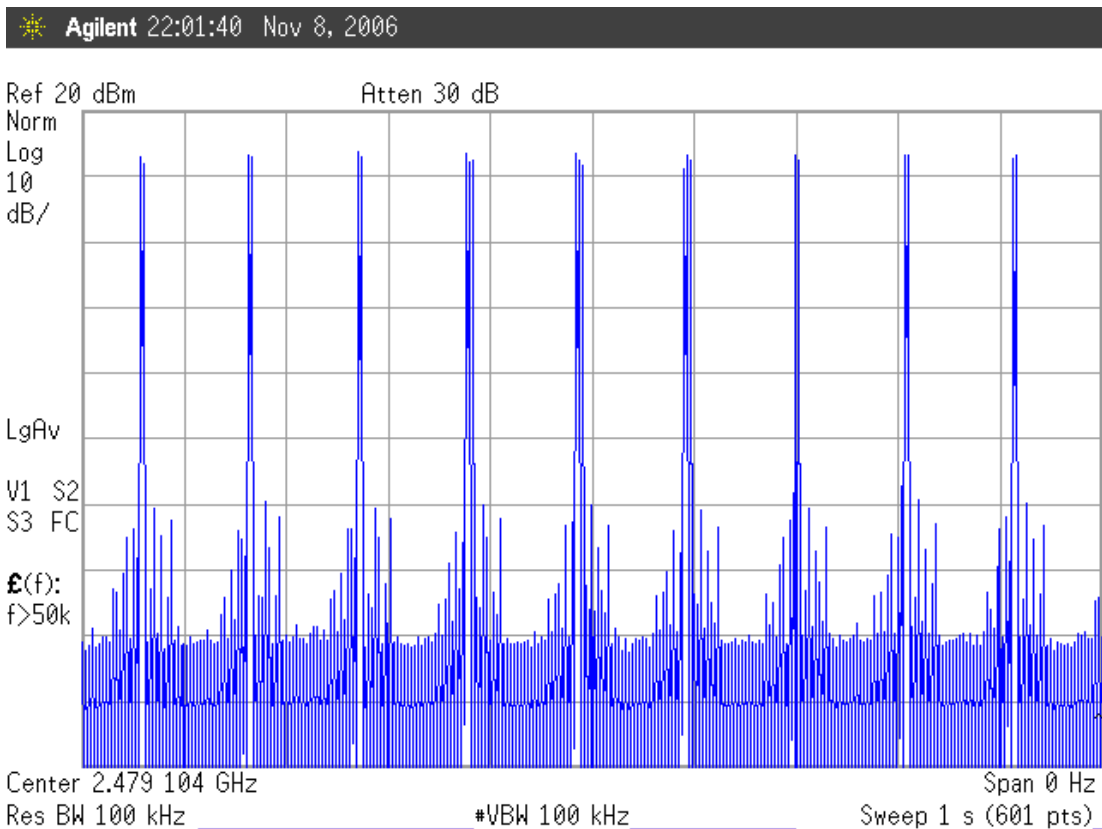
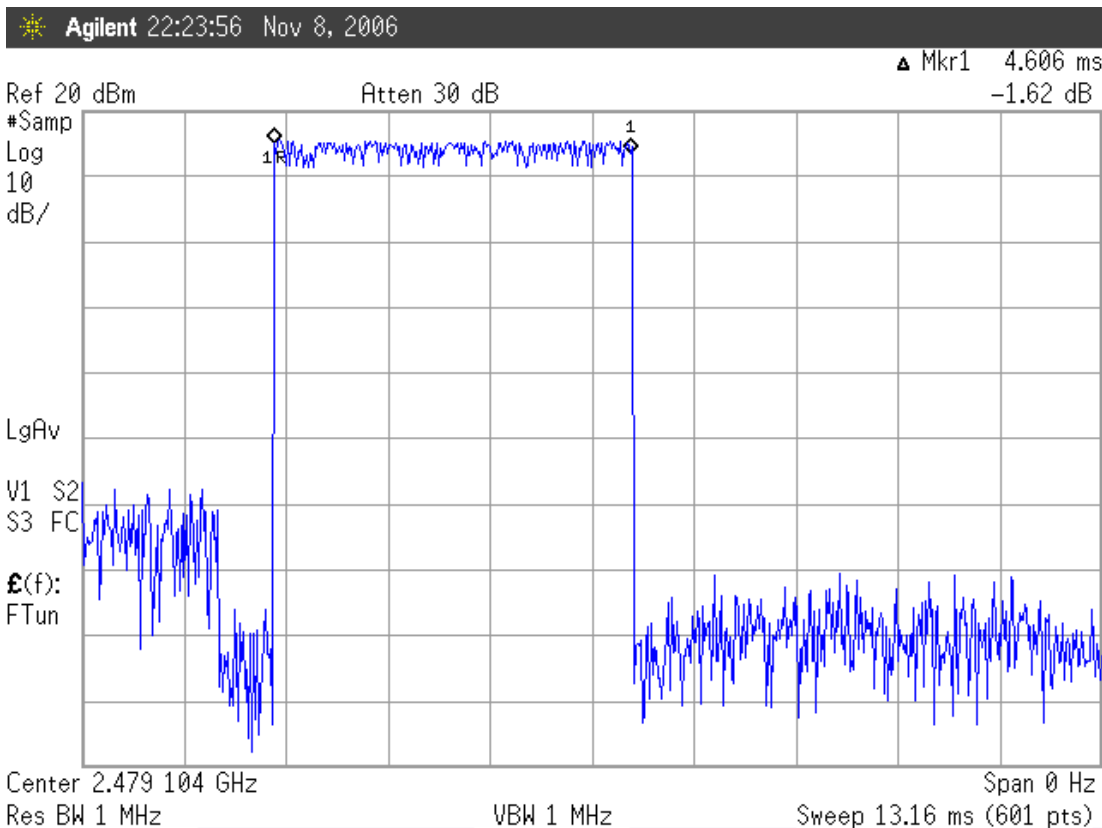

7. NUMBER OF HOPPING CHANNELS MEASUREMENT

7.1. Test Equipment

The following test equipment was used during the number of hopping channels measurement:

Item	Type	Manufacturer	Model No.	Serial No.	Last Cal.	Next Cal.
1.	Spectrum Monitor	Agilent	E4446A	US44300366	Aug. 11, 06'	Aug. 10. 07'

7.2. Block Diagram of Test Setup

The same as section.4.2.

7.3. Specification Limits (§15.247(a)(1)(iii))

Frequency hopping systems which use fewer than 20 hopping frequencies may employ intelligent hopping techniques to avoid interference to other transmissions. Frequency hopping systems may avoid or suppress transmissions on a particular hopping frequency provided that a minimum of 15 non-overlapping channels.

7.4. Operating Condition of EUT

Same as carrier frequency separation measurement which was listed in section 4.4.

7.5. Test Procedure

The transmitter output was connected to the spectrum analyzer. The bandwidth of the fundamental frequency was measure by spectrum analyzer with 100kHz RBW and 100kHz VBW. Sweep=Auto ; Detector function=peak ; Trace=Max hold

7.6. Test Results

PASSED. All the test results are attached in next page.

Test Date : Nov. 09, 2006 Temperature : 25 Humidity : 49 %

The number hopping channel is 20.

8. MAXIMUM PEAK OUTPUT POWER MEASUREMENT

8.1. Test Equipment

The following test equipment was used during the maximum peak output power measurement:

Item	Type	Manufacturer	Model No.	Serial No.	Last Cal.	Next Cal.
1.	Power Meter	Antrisu	ML2487A	6K000001563	Jan. 09, 06'	Jan. 08, 07'
2.	Power Sensor	Antrisu	MA2491A	030873	Jan. 09, 06'	Jan. 08, 07'

8.2. Block Diagram of Test Setup

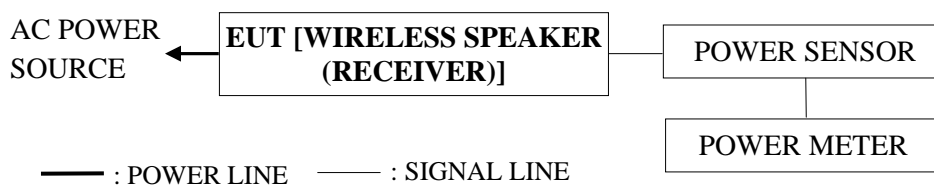

8.3. Specification Limits (§15.247(b)-(1))

The Limits of maximum Peak Output Power for frequency hopping systems in 2400-2483.5MHz is: 0.125Watt. (21dBm)

8.4. Operating Condition of EUT

Same as carrier frequency separation measurement which was listed in 4.4 except the test set up replaced by section 8.2.

8.5. Test Procedure

The transmitter output was connected to the power sensor and record the reading of power meter.

8.6. Test Results

PASSED. All the test results are listed below.

Test Date : Nov. 09, 2006 Temperature : 25 Humidity : 49 %

No.	Channel	Test Frequency	Peak Output Power	Limit
1.	0	2403.328MHz	16.62dBm	21dBm
2.	19	2442.240MHz	17.84dBm	21dBm
3.	37	2479.104MHz	17.66dBm	21dBm

9. EMISSION LIMITATIONS MEASUREMENT

9.1. Test Equipment

The following test equipment was used during the emission limitations measurement:

Item	Type	Manufacturer	Model No.	Serial No.	Last Cal.	Next Cal.
1.	Spectrum Monitor	Agilent	E4446A	US44300366	Aug. 11, 06'	Aug. 10. 07'

9.2. Block Diagram of Test Setup

The same as section.4.2.

9.3. Specification Limits (§15.247(c))

In any 100kHz bandwidth outside the frequency band in which the spread spectrum or digitally modulated intentional radiator is operating, the radio frequency power that is produced by the intentional radiator shall be at least 20dB below that in the 100kHz bandwidth within the band that contains the highest level of the desired power, based on either an RF conducted or a radiated measurement. Attenuation below the general limits specified in Section 15.209(a) is not required. In addition, radiated emissions which fall in restricted bands, as defined in Section 15.205(a), must also comply with the radiated emission limits specified in Section 15.209(a) (See Section 15.205(c)).(This test result attaching to §3.6.3)

9.4. Operating Condition of EUT

Same as carrier frequency separation measurement which was listed in section 4.4.

9.5. Test Procedure

The transmitter output was connected to the spectrum analyzer. Set both RBW and VBW of spectrum analyzer to 100kHz with frequency range from 30MHz to 25GHz.

9.6. Test Results

PASSED. All the test results are attached in next pages.

Test Date : Nov. 08, 2006 Temperature : 26 Humidity : 53 %

1. 2403.328MHz: During 30MHz~25GHz bandwidth. In the 2.4GHz, the -48.91dBm is max value that is lower than 20dB of primary channel.
2. 2442.240MHz: During 30MHz~25GHz bandwidth. In the 2.4GHz, the -49.71dBm is max value that is lower than 20dB of primary channel.
3. 2479.104MHz: During 30MHz~25GHz bandwidth. In the 2.4GHz, the -44.39dBm is max value that is lower than 20dB of primary channel.

Note: The peak above the limit line is the carrier frequency.

9.6.1. Channel 0, Frequency: 2403.328MHz

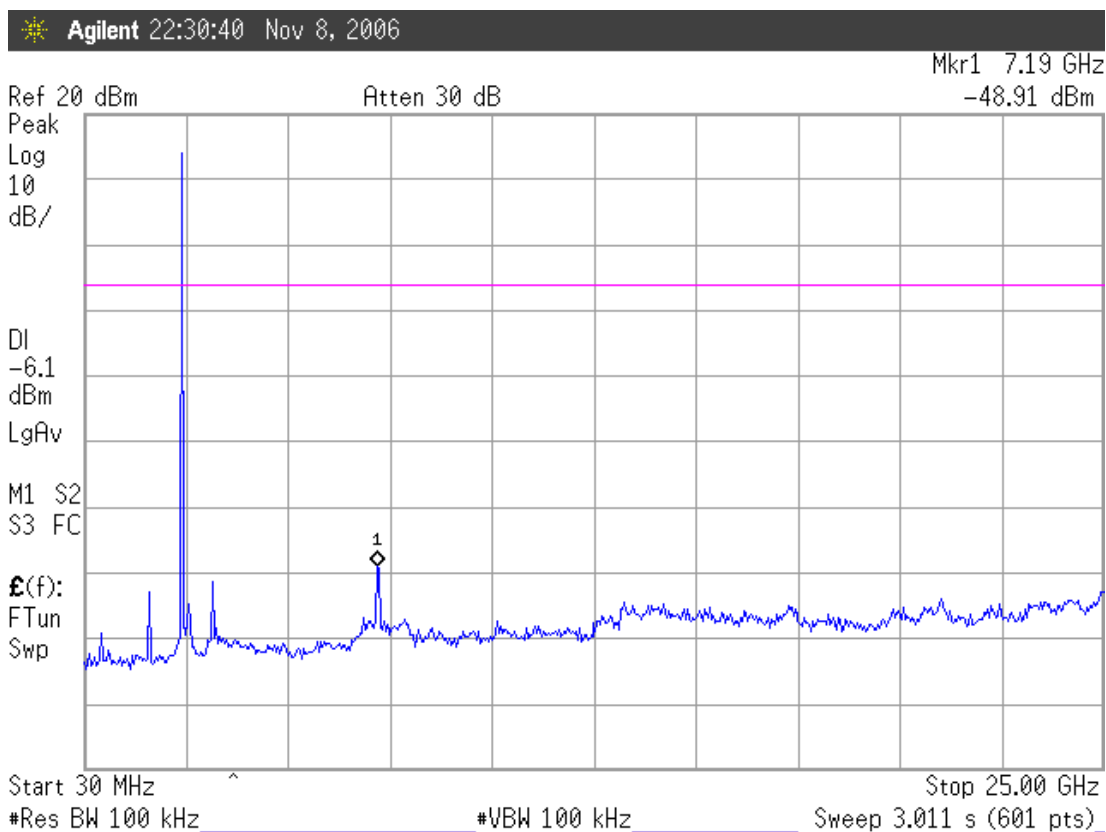

9.6.2. Channel 19, Frequency: 2442.240MHz

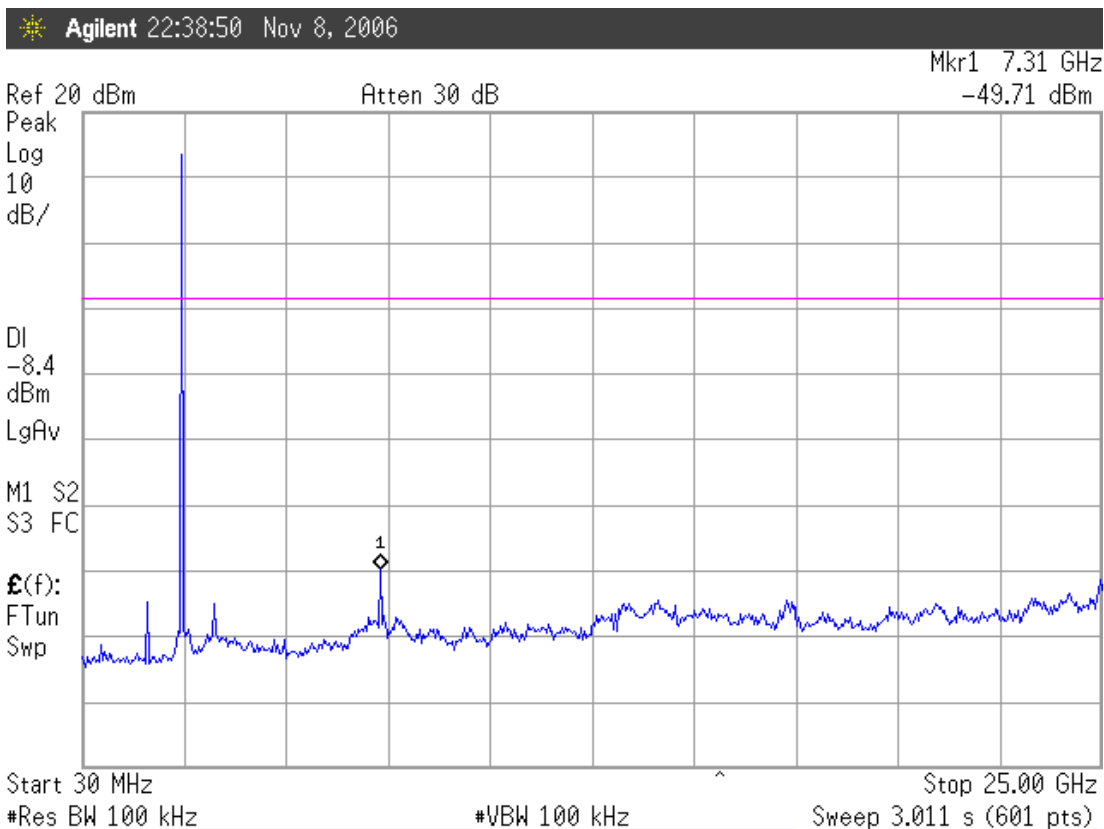

9.6.2.1. Channel 37, Frequency: 2479.104MHz

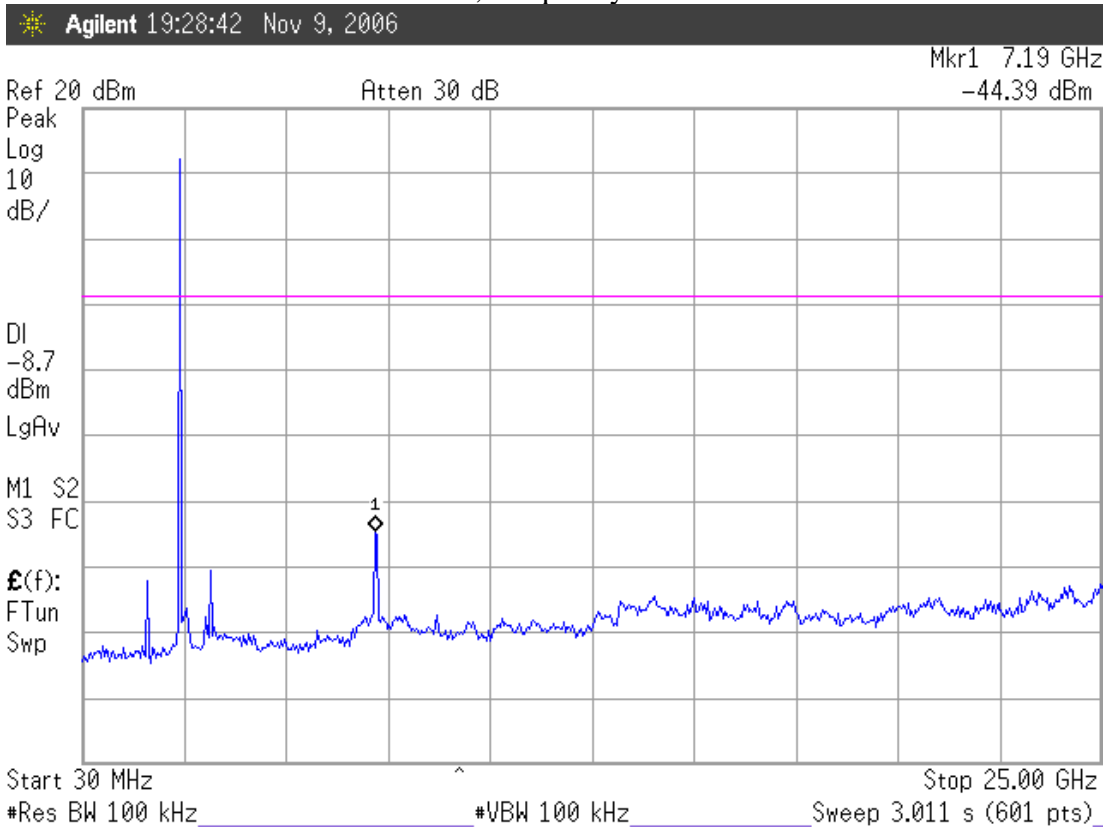

10. BAND EDGES MEASUREMENT

10.1. Test Equipment

The following test equipment was used during the band edges measurement:

Item	Type	Manufacturer	Model No.	Serial No.	Last Cal.	Next Cal.
1.	Spectrum Monitor	Agilent	E4446A	US44300366	Aug. 11, 06'	Aug. 10. 07'

10.2. Block Diagram of Test Setup

The same as section.4.2.

10.3. Specification Limits (§15.247(c))

In any 100kHz bandwidth outside the frequency band in which the spread spectrum or digitally modulated intentional radiator is operating, the radio frequency power that is produced by the intentional radiator shall be at least 20dB below that in the 100kHz bandwidth within the band that contains the highest level of the desired power, based on either an RF conducted or a radiated measurement. Attenuation below the general limits specified in Section 15.209(a) is not required. In addition, radiated emissions which fall in restricted bands, as defined in Section 15.205(a), must also comply with the radiated emission limits specified in Section 15.209(a) (See Section 15.205(c)). (This test result attaching to §3.6.3)

10.4. Operating Condition of EUT

Same as carrier frequency separation measurement which was listed in section 4.4.

10.5. Test Procedure

The transmitter output was connected to the spectrum analyzer. Set both RBW and VBW of spectrum analyzer to 100kHz with suitable frequency span including 100kHz bandwidth from band edge.

10.6. Test Results

PASSED. The testing data was attached in the next pages.

Test Date : Nov. 09, 2006 Temperature : 25 Humidity : 49 %

1. Upper Band edge : The highest emission level is – 43.15dBm on 2.39999GHz.
2. Below Band edge: The highest emission level is – 47.89dBm on 2.48358GHz.

10.6.1. Below Band edge

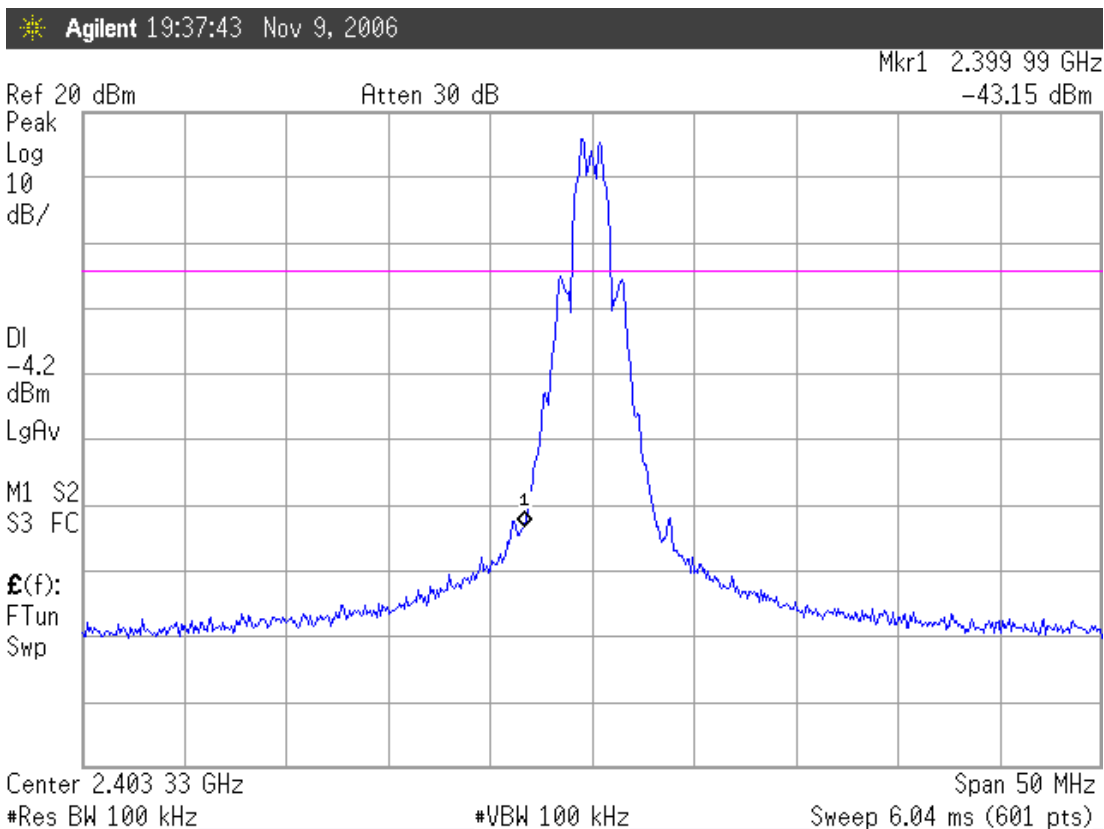

10.6.2. Upper Band edge

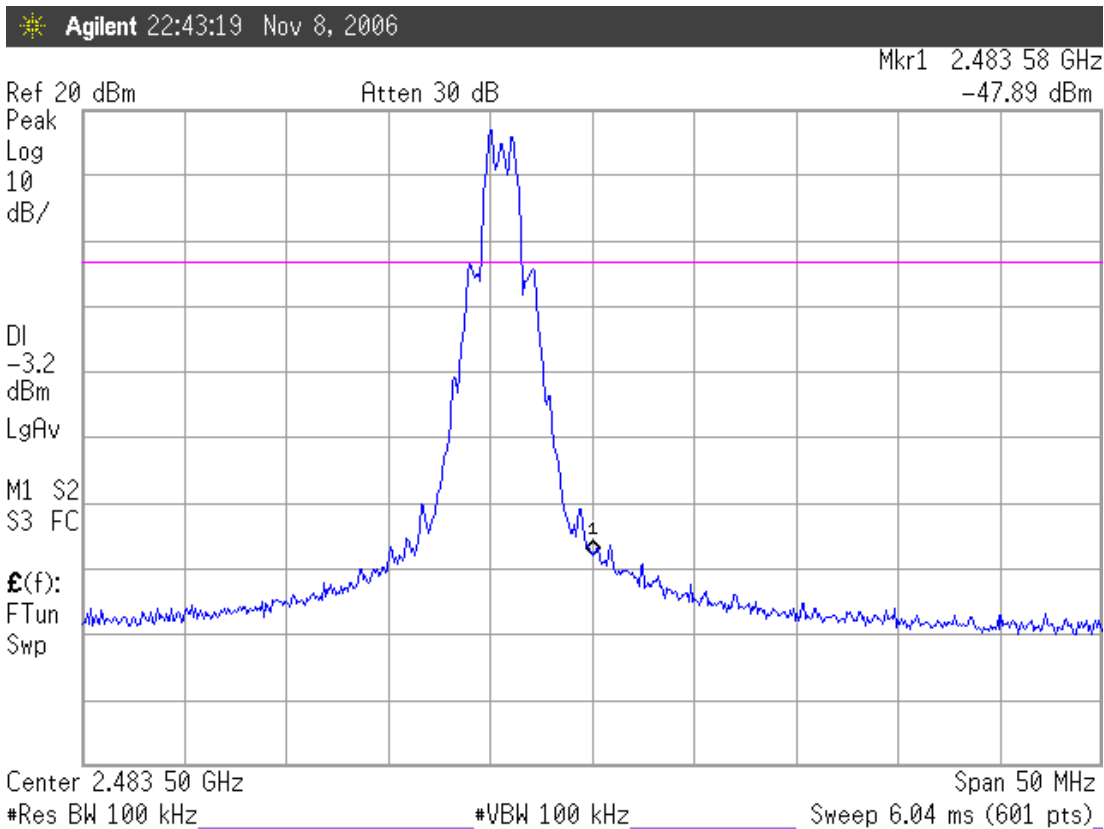

11.DEVIATION TO TEST SPECIFICATIONS

【NONE】