

# **STAREX-IS Indoor BTS System Description**



## 1. General

### 1.1 Overview

BTS(Base Station Transceiver Subsystem) is located between MS and BSC in STAREX-IS using CDMA digital mobile communication technology to control the calls for MS and carries out maintenance function, etc. That is, BTS induces to recognize MS for the first time, downloads necessary data, assigns traffic channel for call request, and opens call paths.

STAREX-IS, a LGE IS-2000 system can best correspond with the network architecture defined in IOS V4.0 standard and IS-2000 standard because BTS is perfect ATM Base system.

Because all BTSs are ATM Base, they can be easily evolved when migrated to 3X, and they have the network structure capable of providing high speed data service being rapidly advanced in technology. And also, they enable the existing T1/E1 interface method between BSC and BTS and the interface with OC-3 of STM-1 grade.

### 1.2 Standard and Spec

1) Max. Carriers(Without TD) : 8FA (3Sector) / 6FA (6Setor)

2) Max. Carriers(With TD) : 6FA (3Sector)

3) Max. Trunk : 48 E1/T1

4) Number of CC : 10EA/Shelf (Max. 640 CE)

5) Type of Amplifier : HPA(30Watts Module)

Note) Output can vary according to the request of a service provider.

6) Number of HPA : 1EA per sector per FA

7) RF Power : 20 Watts / FA

8) Cooling : FAN

9) Environmental Requirements

- Operating Temperature Limits : 0 ~ 46 °C
- Relative Humidity Limits : 10 ~ 85%

10) Dimension

- Depth/Width/Height of Configuration: 700 X 750 X 1886 (mm)

11) Frequency Band

- Uplink(MS → BTS) : 1,850 ~ 1,910 MHz
- Downlink(BTS → MS) : 1,930 ~ 1,990 MHz

12) RF Specification

- Receiver Specifications

Parameter	Description	Comments
Operation Band	1,850 ~ 1,910 MHz	

Diversity	Dual Diversity on Rx	
Frequency Transition	Straight Transition of license Block Operation	
RF Interface	50 $\Omega$ Nominal Impedance	
Noise Figure	5dB (Max)	
Sensitivity	FER is 1.0% or less with 95% Confidence	-119dBm per RF Input Port
Dynamic Range	FER is 1.0% or less with 95% Confidence	Not less than -65dBm /1.23MHz in AWGN and Eb/No of 10 dB $\pm$ 1dB
Conducted Spurious Emissions	Less than -80dBm in 30KHz RBW, RX Band. Less than -60dBm in 30KHz RBW, TX Band. Less than -47dBm in 30KHz RBW, All Other Frequencies	

- Transmitter Specifications

Parameter	Description	Comments
Operation Band	1,930 ~ 1,990 MHz Band	
Diversity	Option of Diversity on TX	
Frequency Transition	Straight Transition of License Block Operation	
Frequency Tolerance	Within $\pm 5 \times 10^{-8}$ of the FA ( $\pm 0.05$ ppm)	
Pilot Time Tolerance	10 $\mu$ s	
Pilot Channel to Code Channel Time Tolerance	The time error between the Pilot Channel and all code channels comprising the Forward CDMA is within $\pm 50$ ns	
Pilot Channel to Code Channel Phase Tolerance	The phase differences between the Pilot Channel and all code channels sharing the same Forward CDMA shall not exceed 0.05radian	
Waveform Quality	$\rho$ is greater than 0.912 (excess power < 0.4dB)	
Total Power	within +2dB and -4dB of nominal power	
Code Domain Power	27dB or more below the total power in each inactive channel	
Conducted Spurious Emission	-45dBc $\pm$ 885kHz @30kHz RBW -13dBm $\pm$ 1.25MHz@ 12.5kHz RBW -13dBm $\pm$ 2.25MHz@ 1MHz RBW	

## 2. Architecture

### 2.1 H/W Structure and function

Structure diagram and block of STAREX-IS BTS system can be explained as follows.

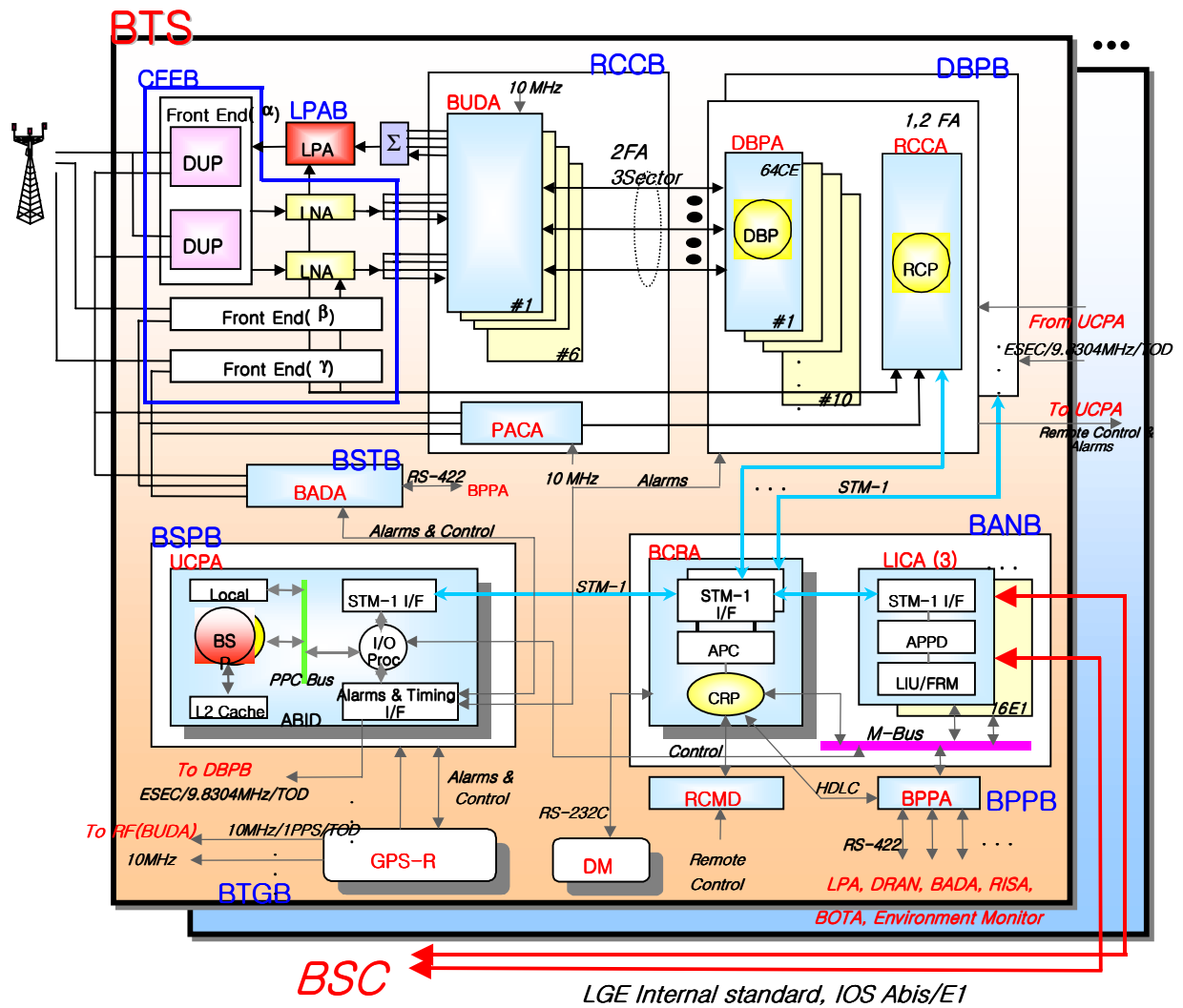

Standard BTS Structure Diagram

1) BANB(BTS ATM Network Block)

BANB makes T1/E1 link interface with the upper BSC, accommodates up to 48E1, and has STM-1 graded I/F with RCP block within BTS. BAN block is composed of UPCA which is the BSC master processor, BCRA to carry out Cell routing function within BTS, LICA with T1/E1 interface, and BPPA interfacing with BSC peripheral.

2) BSPB(Base Station Processor Block)

BSP, BTS control part is composed of Active/Stand and it has been duplicated to be Warm-Standby format. And also, it has initialization function, call(voice and data) processing function, allocation and release function of wire and wireless resources, wire and wireless link management function, and etc.

3) DBPB(Digital Bank Processor Block)

This block carries out digital processing function and it can be classified into DBPA and RCCA block.

4) RCCB (Radio and Channel Control Block)

RCCB is largely classified into BUDA and PACA like the following.

5) HPAB (Linear Power Amplifier Block)

HPAB is a block which receives a transmission signal to amplify it large power.

6) FESB (Front End Block)

FESB is a block processing RF Tx/Rx function and it can be classified as follows.

## 2.2 S/W Structure and Function

### 2.2.1 S/W component definition

#### 1) BCMS (BTS Call and Management Subsystem)

This is a subsystem responsible for processing call of BTS and this is inserted into BSP Processor(UCPA board)..

#### 2) BRMS (BTS cell Router Management Subsystem)

This is a subsystem control BTS ATM cell, inserted into BCRA, and composed of blocks of RCCB, RDLB, RDHB, RSAB, RMSB, and RTMB. This subsystem controls LICA board and through this, carries out trunk interface and AAL2/AAL5 conversion and controls ATM connection.

### 2.2.2 S/W function allocation

Subsystem	Block	Full Name	Function
BCMS		BTS Call & Management Subsystem	Loaded on BSP processor
	BCCB	BTS Call Control Block	BTS call processing
	BHCB	BTS Handoff Control Block	BTS handoff processing
	BTCB	BTS Transparent Message Control Block	BTS transparent message processing
	BRMB	BTS Resource Management Block	BTS resources management
	BPMB	BTS Power Management Block	BTS power management
	BDLB	BTS Down Loading Block	BTS S/W loading
	BDHB	BTS Data Handling Block	BTS configuration and operation data processing
	BSMB	BTS Status Management Block	BTS status control and management
	BAFB	BTS Alarm & Fault Management Block	BTS trouble processing
	BMSB	BTS Measurement & Statistics Block	BTS statistics function
	BTMB	BTS Test Management Block	BTS test function
	BDGB	BTS Diagnostic Block	BTS diagnosis function
BRMS		BTS cell Router Management Subsystem	Loaded on CRP processor
	RCCB	BTS cell Router Connection Control Block	ATM connection control
	RDLB	BTS cell Router Down Loading Block	CRP S/W Downloading
	RDHB	BTS cell Router Data Handling Block	BANU Data handling
	RSAB	BTS cell Router Status & Alarm Management Block	BANU status control and trouble handling
	RMSB	BTS cell Router Measurement & Statistics Block	BANU statistics function
	RTMB	BTS cell Router Test Management Block	BANU test function

### 3. Functions

#### 3.1 Major function

Major functions of BTS system are as follows.

##### 3.1.1 Control function

The control function carries out the following detailed functions.

- 1) Duplication function
- 2) Initialization function
- 3) Allocation and release function of wire/wireless resources
- 4) Management function of wire/wireless link
- 5) Operation and maintenance function
- 6) IPC Test function by each section
- 7) BTS controlling part test function

##### 3.1.2 RF Tx/Rx function

RF Tx/Rx function performs the following detailed functions.

- 1) Amplification of transmitting signal total power
- 2) Amplification of low noise of receiving signal
- 3) Frequency conversion of Tx/Rx signal
- 4) Tx/Rx Diversity function
- 5) LPA(HPA) remote control function (remote re-start and etc.)
- 6) Remote control, status report, and level report function of RF Tx/Rx devices
- 7) Signal and maintenance interface function with RF supervision device, optical repeater, wave transforming repeater, M/W repeater, Tower Top LNA/LPA(HPA), Flash Beacon(System Clock and Even Second), and etc.

##### 3.1.3 Digital processing function

Digital processing function carries out the following detailed functions.

- 1) Modulation/demodulation function
- 2) TD(Transmission Diversity)-OTD(Orthogonal TD), and STS(Space Time Spreading) function
- 3) QOF(Quasi Orthogonal Function)
- 4) Quick Paging Channel
- 5) Deployment and switch over of overhead channel

- 6) Test call function
- 7) DM function

### 3.1.4 GPS receiving function

This function receives visual information from GPS satellite and provides TOD(Time Of Day), 10MHz, and 1PPS to BTS.

### 3.1.5 Backward compatibility for the existing network service

The existing subscribers are provided with the existing service in cdma2000 1x network without restriction through the use of the corresponding CAI message according to protocol revision of MS.

### 3.1.6 Call processing function

Call processing means that mobile subscribers allocate many resources of the system to connect appropriate call paths. Call processing can be generally classified into Mobile To Mobile call and Mobile To Land call, and Land to Mobile call according to call processing target subscribers. Call processing procedure is composed of originating call setting, terminating call setting, and call setting release step.

BTS processes originating and terminating data for call, circuit, and high, middle, and low data and performs the following detailed functions.

- 1) Power control function
- 2) Voice call function
- 3) Data call function
- 4) SVD function
- 5) Hopping beacon function
- 6) Spot Beam function
- 7) PACA function
- 8) Test call function
- 9) Priority Call function

10) Video phone function

### 3.1.7 H/O processing function

This function maintains the call in service not to be cut off for enhancing the call quality in mobile exchange system when mobile subscribers get out of the current service area and move other adjacent area.

### 3.1.8 Operation maintenance function

This carries out processor status management, device status management, configuration information, operation information management functions, and etc.

- 1) Diagnosis by itself and automatic/manual test
- 2) OCNS function
- 3) OUNS function
- 4) CAI performance test for clockwise and reverse direction link
- 5) TPTL(Transmit Power Tracking Loop) function
- 6) Overload control function (can set threshold value in BSM/BTS.)
- 7) Statistics information collection and report function
- 8) Management of BTS resources
- 9) H/W and S/W Alarm collection and report function
- 10) DM function
- 11) Specific Call Trace function (Call Flow and message content display)
- 12) Major Processor Debugging function
- 13) Call Simulation function
- 14) Transmission path test function
- 15) Function to diagnoses all processors and Devices in BTS in detail
- 16) Function to reserve channel element for handoff by FA and Sector

### 3.1.9 Supplementary device interface function

This function carries out the following detailed functions.

- 1) Coupler can be attached for repeater interface and attachment section is as follows.
- 2) IPC Node distribution function for supplementary device interface (for NMS)
- 3) Provides port to provide GPS 10MHz for supplementary device.
- 4) Provides 1PPS input/output port for supplementary device
- 5) Provides Even second/System clock Port

## 4. Abbreviations

● ABID	Alarm Buffer Interface Daughter board
● ALMA	ATM Low Speed Subs. Mux/Dmx b'd Assembly
● ALPA	ATM Low Speed Subs. Physical b'd Assembly
● ALSB	ATM Low Speed Subs. Interface Block
● AMPB	Alarm Management Processor b'd Block
● ANSI	American National Standard Institute
● AOTA	ATM Optical Transceiver b'd Assembly
● APPD	Aal type 2/5 Protocol Processing Daughter board
● ASAP	Alarm Severity Assignment Profile
● ASIA	ATM STM-1 Interface b'd Assembly
● ASCA	ATM Switch Controller b'd Assembly
● ASMB	ATM Switch Module Block
● ATM	Asynchronous Transfer Mode
● ATSA	Aal type Two Service b'd Assembly
● ATSB	Aal type Two Service Block
● BADA	BTS Analyze & Diagnostic Assembly
● BANB	BTS ATM Network Block
● BCMS	BTS Call & Management Subsystem
● BSSB	BTS Call Control Block
● BCRA	BTS Cell Routing Assembly
● BDGB	BTS Diagnostic Block
● BDHB	BTS Data Handling Block
● BDLB	BTS Down Loading Block
● BHCA	Busy Hour Call Attempt
● BHCB	BTS Handoff Control Block
● BPF	Band Pass Filter
● BPMB	BTS Power Management Block
● BPPA	BTS Peripheral Control Processor Board Assembly
● BRMB	BTS Resource Management Block
● BRMS	BTS Cell Router Management Subsystem
● BSC	Base Station Controller
● BSM	Base Station Manager
● BSMB	BTS Measurement Block
● BTCB	BTS Transparent Message Control Block
● BTS	Base Transceiver System
● BUDA	BTS sector conversion Up/Down converter Assembly
● CAMA	Centralized Automatic Message Account
● CAMB	Central ATM Switch Module Block
● CCP	Call Control Processor
● CCS No.7	Common Channel Signaling Number 7
● CDMA	Code Division Multiple Access
● CE	Channel Element
● CEFU	Compact End Front Unit
● DBPA	Digital Bank Processor b'd Assembly
● DM	Diagnostic Monitor
● DRAN	Digital Radio Access Network
● DS	Direct Sequence
● DTMF	Dual Tone Multi-Frequency
● Erl	Erlang



● ESN	Electronic Serial Number
● EVRC	Enhanced Variable Rate Coder & Decoder
● FA	Frequency Assignment
● FERA	Fast Ethernet Routing b'd Assembly
● GPS	Global Positioning System
● GPS-R	GPS-Receiver
● GPS-D	GPS-Distribution
● GUI	Graphical User Interface
● H/O	Handoff
● H/W	Hardware
● IF	Intermediate Frequency
● IMT-2000	International Mobile Telecommunication 2000
● IOS	Inter-Operability Specification
● IS	Interim Standard
● L	Land
● LICA	Line Interface Controller b'd Assembly
● LNA	Low Noise Amplifier
● LPA	Linear Power Amplifier
● M	Mobile
● MS	Mobile Station
● MSC	Mobile Switching Center
● NCP	Network Controller Processor
● NMS	Network Management System
● OCNS	Other Cell Noise Simulator
● OTA	Over The air Activation
● OTD	Orthogonal Transmission Diversity
● OUNS	Other User Noise Simulator
● PACA	Power Adjustment & Control b'd Assembly
● PCFB	Protocol Control Function Block
● PCP	Protocol Controller Processor
● PDSN	Packet Data Serving Node
● PIP	Protocol Interface Processor
● PLD	Programmable Loading Data
● QOF	Quasi-Orthogonal Functions
● QoS	Quality of Service
● QPCH	Quick Paging Channel
● RCCA	Radio & Channel Control board Assembly
● RCCB	Radio & Channel Control Block (H/W Block)
● RCCB	BTS Cell Router Connection Control Block
● RCP	RF Controller Processor
● RDHB	BTS Cell Router Data Handling Block
● RDLB	BTS Cell Router Down Loading Block
● RF	Radio Frequency
● RMSB	BTS Cell Router Measurement & Statistics Block
● R-P	Radio-Packet
● RSAB	BTS Cell Router Status & Alarm Management Block
● RTMB	BTS Cell Router Test Management Block
● SMP	Selector Master Processor
● STIA	Signaling Terminal Interface b'd Assembly
● STP	Signaling Transfer Point
● SVD	Simultaneous Voice and Data service
● TOD	Time Of Day
● TPTL	Transmit Power Tracking Loop

