



A D T

FCC TEST REPORT (15.407)

REPORT NO.: RF981009L05-1

MODEL NO.: WMDA-119AN

RECEIVED: Oct. 09, 2009

TESTED: Dec. 09, 2009 ~ Jan. 04, 2010

ISSUED: Jan. 06, 2010

APPLICANT: LG Electronics USA

ADDRESS: 1000 Sylvan Avenue, Englewood Cliffs, NJ 07632,
United States

ISSUED BY: Bureau Veritas Consumer Products Services (H.K.)
Ltd., Taoyuan Branch

LAB ADDRESS: No. 47, 14th Ling, Chia Pau Tsuen, Lin Kou Hsiang,
Taipei Hsien 244, Taiwan, R.O.C.

TEST LOCATION: No. 19, Hwa Ya 2nd Rd, Wen Hwa Tsuen, Kwei
Shan Hsiang, Taoyuan Hsien 333, Taiwan, R.O.C.

This test report consists of 59 pages in total. It may be duplicated completely for legal use with the approval of the applicant. It should not be reproduced except in full, without the written approval of our laboratory. The client should not use it to claim product endorsement by TAF or any government agencies. The test results in the report only apply to the tested sample.





A D T

TABLE OF CONTENTS

1.	CERTIFICATION.....	4
2.	SUMMARY OF TEST RESULTS	5
2.1	MEASUREMENT UNCERTAINTY.....	5
3.	GENERAL INFORMATION.....	6
3.1	GENERAL DESCRIPTION OF EUT	6
3.2	DESCRIPTION OF TEST MODES	7
3.2.1	CONFIGURATION OF SYSTEM UNDER TEST	7
3.2.2	TEST MODE APPLICABILITY AND TESTED CHANNEL DETAIL	8
3.3	GENERAL DESCRIPTION OF APPLIED STANDARDS	10
3.4	DESCRIPTION OF SUPPORT UNITS	10
4.	TEST TYPES AND RESULTS	11
4.1	RADIATED EMISSION MEASUREMENT	11
4.1.1	LIMITS OF RADIATED EMISSION MEASUREMENT.....	11
4.1.2	LIMITS OF UNWANTED EMISSION OUT OF THE RESTRICTED BANDS	11
4.1.3	TEST INSTRUMENTS.....	12
4.1.4	TEST PROCEDURES	13
4.1.5	DEVIATION FROM TEST STANDARD.....	13
4.1.6	TEST SETUP.....	14
4.1.7	EUT OPERATING CONDITION.....	14
4.1.8	TEST RESULTS	15
4.2	CONDUCTED EMISSION MEASUREMENT	24
4.2.1	LIMITS OF CONDUCTED EMISSION MEASUREMENT.....	24
4.2.2	TEST INSTRUMENTS.....	24
4.2.3	TEST PROCEDURES	25
4.2.4	DEVIATION FROM TEST STANDARD.....	25
4.2.5	TEST SETUP.....	26
4.2.6	EUT OPERATING CONDITIONS	26
4.2.7	TEST RESULTS	27
4.3	MAXIMUM CONDUCTED OUTPUT POWER MEASUREMENT	33
4.3.1	LIMITS OF MAXIMUM CONDUCTED OUTPUT POWER MEASUREMENT.....	33
4.3.2	TEST INSTRUMENTS.....	33
4.3.3	TEST PROCEDURES	34
4.3.4	DEVIATION FROM TEST STANDARD.....	34
4.3.5	TEST SETUP.....	34
4.3.6	EUT OPERATING CONDITIONS	34
4.3.7	TEST RESULTS	35



A D T

4.4	PEAK POWER EXCURSION MEASUREMENT	37
4.4.1	LIMITS OF PEAK POWER EXCURSION MEASUREMENT	37
4.4.2	TEST INSTRUMENTS.....	37
4.4.3	TEST PROCEDURE.....	37
4.4.4	DEVIATION FROM TEST STANDARD.....	38
4.4.5	TEST SETUP	38
4.4.6	EUT OPERATING CONDITIONS	38
4.4.7	TEST RESULTS	39
4.5	PEAK POWER SPECTRAL DENSITY MEASUREMENT	41
4.5.1	LIMITS OF PEAK POWER SPECTRAL DENSITY MEASUREMENT	41
4.5.2	TEST INSTRUMENTS.....	41
4.5.3	TEST PROCEDURES	41
4.5.4	DEVIATION FROM TEST STANDARD.....	42
4.5.5	TEST SETUP	42
4.5.6	EUT OPERATING CONDITIONS	42
4.5.7	TEST RESULTS	43
4.6	FREQUENCY STABILITY.....	44
4.6.1	LIMITS OF FREQUENCY STABILITY MEASUREMENT	44
4.6.2	TEST INSTRUMENTS.....	44
4.6.3	TEST PROCEDURE.....	44
4.6.4	DEVIATION FROM TEST STANDARD.....	45
4.6.5	TEST SETUP	45
4.6.6	EUT OPERATING CONDITION.....	45
4.6.7	TEST RESULTS	46
4.7	BAND EDGES MEASUREMENT	47
4.7.1	TEST INSTRUMENTS.....	47
4.7.2	TEST PROCEDURE.....	48
4.7.3	EUT OPERATING CONDITION.....	48
4.7.4	TEST RESULTS	49
5.	PHOTOGRAPHS OF THE TEST CONFIGURATION.....	57
6.	INFORMATION ON THE TESTING LABORATORIES	58
7.	APPENDIX A - MODIFICATIONS RECORDERS FOR ENGINEERING CHANGES TO THE EUT BY THE LAB	59



A D T

1. CERTIFICATION

PRODUCT: RF Transmitter
MODEL NO.: WMDA-119AN
BRAND: LG
APPLICANT: LG Electronics USA
TESTED: Dec. 09, 2009 ~ Jan. 04, 2010
TEST SAMPLE: ENGINEERING SAMPLE
STANDARDS: **FCC Part 15, Subpart E (Section 15.407)**
ANSI C63.4-2003

The above equipment (Model: WMDA-119AN) has been tested by **Bureau Veritas Consumer Products Services (H.K.) Ltd., Taoyuan Branch**, and found compliance with the requirement of the above standards. The test record, data evaluation & Equipment Under Test (EUT) configurations represented herein are true and accurate accounts of the measurements of the sample's EMC characteristics under the conditions specified in this report.

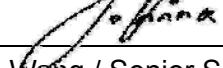
PREPARED BY :  , **DATE** : Jan. 06, 2010
Joanna Wang / Senior Specialist

TECHNICAL ACCEPTANCE :  , **DATE** : Jan. 06, 2010
Responsible for RF Long Chen / Senior Engineer

APPROVED BY :  , **DATE** : Jan. 06, 2010
Gary Chang / Assistant Manager



A D T

2. SUMMARY OF TEST RESULTS

The EUT has been tested according to the following specifications:

APPLIED STANDARD: FCC PART 15, SUBPART E (SECTION 15.407)			
STANDARD SECTION	TEST TYPE AND LIMIT	RESULT	REMARK
15.407(b)(5)	AC Power Conducted Emission	PASS	Meet the requirement of limit. Minimum passing margin is -22.48dB at 21.212MHz.
15.407(b/1/2/3)(b)(5)	Electric Field Strength Spurious Emissions, 30MHz ~ 40000MHz	PASS	Meet the requirement of limit. Minimum passing margin is -1.1dB at 10620.00MHz.
15.407(a/1/2/3)	Peak Transmit Power	PASS	Meet the requirement of limit.
15.407(a)(6)	Peak Power Excursion	PASS	Meet the requirement of limit.
15.407(a/1/2/3)	Peak Power Spectral Density	PASS	Meet the requirement of limit.
15.407(g)	Frequency Stability	PASS	Meet the requirement of limit.
15.203	Antenna Requirement	PASS	No antenna connector is used.

2.1 MEASUREMENT UNCERTAINTY

Where relevant, the following measurement uncertainty levels have been estimated for tests performed on the EUT as specified in CISPR 16-4-2:

MEASUREMENT	FREQUENCY	UNCERTAINTY
Conducted emissions	150kHz ~ 30MHz	2.44dB
Radiated emissions	30MHz ~ 200MHz	3.19dB
	200MHz ~ 1000MHz	3.21dB
	1GHz ~ 18GHz	2.26dB
	18GHz ~ 40GHz	1.94dB

This uncertainty represents an expanded uncertainty expressed at approximately the 95% confidence level using a coverage factor of $k = 2$.

3. GENERAL INFORMATION

3.1 GENERAL DESCRIPTION OF EUT

EUT	RF Transmitter
MODEL NO.	WMDA-119AN
FCC ID	BEJ-119AN
POWER SUPPLY	5Vdc
MODULATION TYPE	16QAM
MODULATION TECHNOLOGY	OFDM
OPERATING FREQUENCY	5190 ~ 5310MHz & 5510 ~ 5550MHz
NUMBER OF CHANNEL	5190 ~ 5310MHz: 4 5510 ~ 5550MHz: 2
OUTPUT POWER	45.1mW for 5190 ~ 5310MHz 43.6mW for 5510 ~ 5550MHz
ANTENNA TYPE	Dipole & Monopole antenna with 3.5dBi gain
ANTENNA CONNECTOR	NA
DATA CABLE	NA
I/O PORTS	USB
ACCESSORY DEVICES	NA

NOTE:

1. The EUT is a RF Transmitter. The reports are listed as below:

OPERATING FREQUENCY BAND	TEST STANDARD	REFERENCE REPORT
5755~5795 MHz	FCC Part 15, Subpart C (Section 15.247)	RF981009L05
5190~5310MHz, 5510~5550MHz	FCC Part 15, Subpart E (Section 15.407)	RF981009L05-1
5270~5310MHz, 5510~5550MHz (For DFS report)	FCC Part 15, Subpart E (Section 15.407)	RF981009L05-2

2. The frequency bands used in this EUT are listed as follows.

FREQUENCY BAND (MHz)	5190~5310	5510~5550	5755~5795
TX (40MHz)	√	√	√

3. The EUT incorporates a MIMO function. Physically, the EUT provides four completed transmitters and one receiver.

MODULATION MODE	TX FUNCTION
TX (40MHz)	4TX

4. The above EUT information was declared by manufacturer and for more detailed features description, please refer to the manufacturer's specifications or user's manual.

3.2 DESCRIPTION OF TEST MODES

For 5190 ~ 5310MHz

4 channels are provided for TX (40MHz)

CHANNEL	FREQUENCY	CHANNEL	FREQUENCY
1	5190 MHz	3	5270 MHz
2	5230 MHz	4	5310 MHz

For 5510 ~ 5550MHz

2 channels are provided for TX (40MHz)

CHANNEL	FREQUENCY	CHANNEL	FREQUENCY
5	5510 MHz	6	5550 MHz

3.2.1 CONFIGURATION OF SYSTEM UNDER TEST

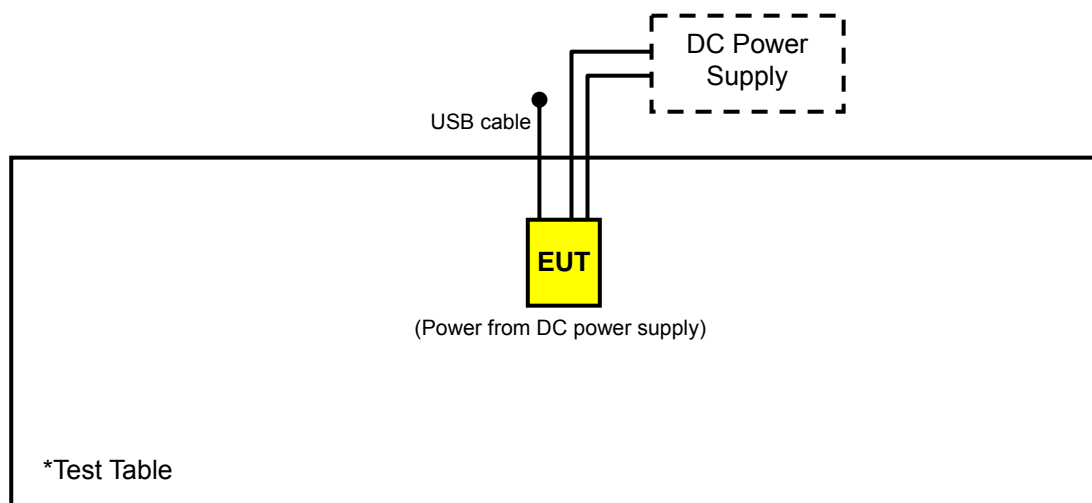

3.2.2 TEST MODE APPLICABILITY AND TESTED CHANNEL DETAIL

EUT CONFIGURE MODE	APPLICABLE TO				DESCRIPTION
	RE \geq 1G	RE<1G	PLC	APCM	
-	√	√	√	√	-

Where **RE \geq 1G**: Radiated Emission above 1GHz **RE<1G**: Radiated Emission below 1GHz
PLC: Power Line Conducted Emission **APCM**: Antenna Port Conducted Measurement

RADIATED EMISSION TEST (ABOVE 1GHz):

- Pre-Scan has been conducted to determine the worst-case mode from all possible combinations between available modulations, data rates and antenna ports (if EUT with antenna diversity architecture).
- Following channel(s) was (were) selected for the final test as listed below.

MODE	FREQ. BAND (MHz)	AVAILABLE CHANNEL	TESTED CHANNEL	MODULATION TECHNOLOGY
TX (40MHz)	5190-5310	1 to 4	1, 2, 3, 4	OFDM
TX (40MHz)	5510-5550	5 to 6	5, 6	OFDM

RADIATED EMISSION TEST (BELOW 1GHz):

- Pre-Scan has been conducted to determine the worst-case mode from all possible combinations between available modulations, data rates and antenna ports (if EUT with antenna diversity architecture).
- Following channel(s) was (were) selected for the final test as listed below.

MODE	FREQ. BAND (MHz)	AVAILABLE CHANNEL	TESTED CHANNEL	MODULATION TECHNOLOGY
TX (40MHz)	5190-5310	1 to 4	1, 4	OFDM
TX (40MHz)	5510-5550	5 to 6	5	OFDM

POWER LINE CONDUCTED EMISSION TEST:

- Pre-Scan has been conducted to determine the worst-case mode from all possible combinations between available modulations, data rates and antenna ports (if EUT with antenna diversity architecture).
- Following channel(s) was (were) selected for the final test as listed below.

MODE	FREQ. BAND (MHz)	AVAILABLE CHANNEL	TESTED CHANNEL	MODULATION TECHNOLOGY
TX (40MHz)	5190-5310	1 to 4	1, 4	OFDM
TX (40MHz)	5510-5550	5 to 6	5	OFDM



BANDEDGE MEASUREMENT:

- Pre-Scan has been conducted to determine the worst-case mode from all possible combinations between available modulations, data rates and antenna ports (if EUT with antenna diversity architecture).
- Following channel(s) was (were) selected for the final test as listed below.

MODE	FREQ. BAND (MHz)	AVAILABLE CHANNEL	TESTED CHANNEL	MODULATION TECHNOLOGY
TX (40MHz)	5190-5310	1 to 4	1, 4	OFDM
TX (40MHz)	5510-5550	5 to 6	5, 6	OFDM

ANTENNA PORT CONDUCTED MEASUREMENT:

- This item includes all test value of each mode, but only includes spectrum plot of worst value of each mode.
- Pre-Scan has been conducted to determine the worst-case mode from all possible combinations between available modulations, data rates and antenna ports (if EUT with antenna diversity architecture).
- Following channel(s) was (were) selected for the final test as listed below.

MODE	FREQ. BAND (MHz)	AVAILABLE CHANNEL	TESTED CHANNEL	MODULATION TECHNOLOGY
TX (40MHz)	5190-5310	1 to 4	1, 2, 3, 4	OFDM
TX (40MHz)	5510-5550	5 to 6	5, 6	OFDM

TEST CONDITION:

APPLICABLE TO	ENVIRONMENTAL CONDITIONS	INPUT POWER (SYSTEM)	TESTED BY
RE \geq 1G	25deg. C, 65%RH, 1016 hPa	120Vac, 60 Hz	Mark Liao
RE $<$ 1G	25deg. C, 65%RH, 1017 hPa	120Vac, 60 Hz	Mark Liao
PLC	23deg. C, 68%RH, 1016 hPa	120Vac, 60 Hz	Sun Lin
APCM	22deg. C, 63%RH, 1015 hPa	120Vac, 60 Hz	Dean Wang



3.3 GENERAL DESCRIPTION OF APPLIED STANDARDS

The EUT is a RF Product. According to the specifications of the manufacturer, it must comply with the requirements of the following standards:

FCC Part 15, Subpart E (15.407)
ANSI C63.4-2003

All test items have been performed and recorded as per the above standards.

NOTE: The EUT is also considered as a kind of computer peripheral, because the connection to computer is necessary for typical use. It has been verified to comply with the requirements of FCC Part 15, Subpart B, Class B (DoC). The test report has been issued separately.

3.4 DESCRIPTION OF SUPPORT UNITS

The EUT has been tested as an independent unit together with other necessary accessories or support units. The following support units or accessories were used to form a representative test configuration during the tests.

NO.	PRODUCT	BRAND	MODEL NO.	SERIAL NO.	FCC ID
1	DC POWER SUPPLY	TOP WARD	6603A	725906	NA

NO.	SIGNAL CABLE DESCRIPTION OF THE ABOVE SUPPORT UNITS
1	NA

NOTE:

1. All power cords of the above support units are non-shielded (1.8m).
2. Item 1 was under test table during test.

4. TEST TYPES AND RESULTS

4.1 RADIATED EMISSION MEASUREMENT

4.1.1 LIMITS OF RADIATED EMISSION MEASUREMENT

Emissions radiated outside of the specified bands, shall be according to the general radiated limits in 15.209 as following:

FREQUENCIES (MHz)	FIELD STRENGTH (microvolts/meter)	MEASUREMENT DISTANCE (meters)
0.009 ~ 0.490	2400/F(kHz)	300
0.490 ~ 1.705	24000/F(kHz)	30
1.705 ~ 30.0	30	30
30 ~ 88	100	3
88 ~ 216	150	3
216 ~ 960	200	3
Above 960	500	3

NOTE:

1. The lower limit shall apply at the transition frequencies.
2. Emission level (dBuV/m) = 20 log Emission level (uV/m).
3. As shown in 15.35(b), for frequencies above 1000MHz, the field strength limits are based on average detector, however, the peak field strength of any emission shall not exceed the maximum permitted average limits, specified above by more than 20dB under any condition of modulation.

4.1.2 LIMITS OF UNWANTED EMISSION OUT OF THE RESTRICTED BANDS

FREQUENCIES (MHz)	EIRP LIMIT (dBm)	EQUIVALENT FIELD STRENGTH AT 3m (dBµV/m) *NOTE
	PK	PK
5150 ~ 5350	-27	68.3
5470 ~ 5725	-27	68.3

NOTE:

The following formula is used to convert the equipment isotropic radiated power (eirp) to field strength:

$$E = \frac{1000000\sqrt{30P}}{3} \mu\text{V/m, where P is the eirp (Watts).}$$



4.1.3 TEST INSTRUMENTS

DESCRIPTION & MANUFACTURER	MODEL NO.	SERIAL NO.	DATE OF CALIBRATION	DUE DATE OF CALIBRATION
Test Receiver ROHDE & SCHWARZ	ESI7	838496/016	Dec. 29, 2009	Dec. 28, 2010
Spectrum Analyzer ROHDE & SCHWARZ	FSP40	100076	May 26, 2009	May 25, 2010
BILOG Antenna SCHWARZBECK	VULB9168	9168-155	Apr. 29, 2009	Apr. 28, 2010
HORN Antenna SCHWARZBECK	BBHA 9120 D	9120D-405	Jan. 12, 2009	Jan. 11, 2010
HORN Antenna SCHWARZBECK	BBHA 9170	BBHA9170242	Jan. 06, 2009	Jan. 05, 2010
Preamplifier Agilent	8449B	3008A01961	Nov. 04, 2009	Nov. 03, 2010
Preamplifier Agilent	8447D	2944A10738	Nov. 04, 2009	Nov. 03, 2010
RF signal cable HUBER+SUHNNER	SUCOFLEX 104	274041/4	Aug. 28, 2009	Aug. 27, 2010
RF signal cable HUBER+SUHNNER	SUCOFLEX 104	283397/4	Aug. 28, 2009	Aug. 27, 2010
Software ADT.	ADT_Radiated_ V7.6.15.9.2	NA	NA	NA
Antenna Tower inn-co GmbH	MA 4000	010303	NA	NA
Antenna Tower Controller inn-co GmbH	CO2000	019303	NA	NA
Turn Table ADT.	TT100.	TT93021704	NA	NA
Turn Table Controller ADT.	SC100.	SC93021704	NA	NA
26GHz ~ 40GHz Amplifier	EM26400	07026401	Aug. 27, 2009	Aug. 26, 2010

- NOTE:**
1. The calibration interval of the above test instruments is 12 months and the calibrations are traceable to NML/ROC and NIST/USA.
 2. The test was performed in HwaYa Chamber 4.
 3. The horn antenna and HP preamplifier (model: 8449B) are used only for the measurement of emission frequency above 1GHz if tested.
 4. The FCC Site Registration No. is 988962.
 5. The IC Site Registration No. is IC7450F-4.

4.1.4 TEST PROCEDURES

- a. The EUT was placed on the top of a rotating table 0.8 meters above the ground at a 3 meter semi-anechoic chamber. The table was rotated 360 degrees to determine the position of the highest radiation.
- b. The EUT was set 3 meters away from the interference-receiving antenna, which was mounted on the top of a variable-height antenna tower.
- c. The antenna is a broadband antenna, and its height is varied from one meter to four meters above the ground to determine the maximum value of the field strength. Both horizontal and vertical polarizations of the antenna are set to make the measurement.
- d. For each suspected emission, the EUT was arranged to its worst case and then the antenna was tuned to heights from 1 meter to 4 meters and the rotatable table was turned from 0 degrees to 360 degrees to find the maximum reading.
- e. The test-receiver system was set to Peak Detect Function and Specified Bandwidth with Maximum Hold Mode.
- f. If the emission level of the EUT in peak mode was 10dB lower than the limit specified, then testing could be stopped and the peak values of the EUT would be reported. Otherwise the emissions that did not have 10dB margin would be re-tested one by one using peak, quasi-peak or average method as specified and then reported in a data sheet.

NOTE:

1. The resolution bandwidth and video bandwidth of test receiver/spectrum analyzer is 120kHz for Peak detection (PK) and Quasi-peak detection (QP) at frequency below 1GHz.
2. The resolution bandwidth of test receiver/spectrum analyzer is 1MHz and video bandwidth is 3MHz for Peak detection at frequency above 1GHz.
3. The resolution bandwidth of test receiver/spectrum analyzer is 1MHz and the video bandwidth is 10Hz for Average detection (AV) at frequency above 1GHz.
4. All modes of operation were investigated and the worst-case emissions are reported.

4.1.5 DEVIATION FROM TEST STANDARD

No deviation.

4.1.6 TEST SETUP

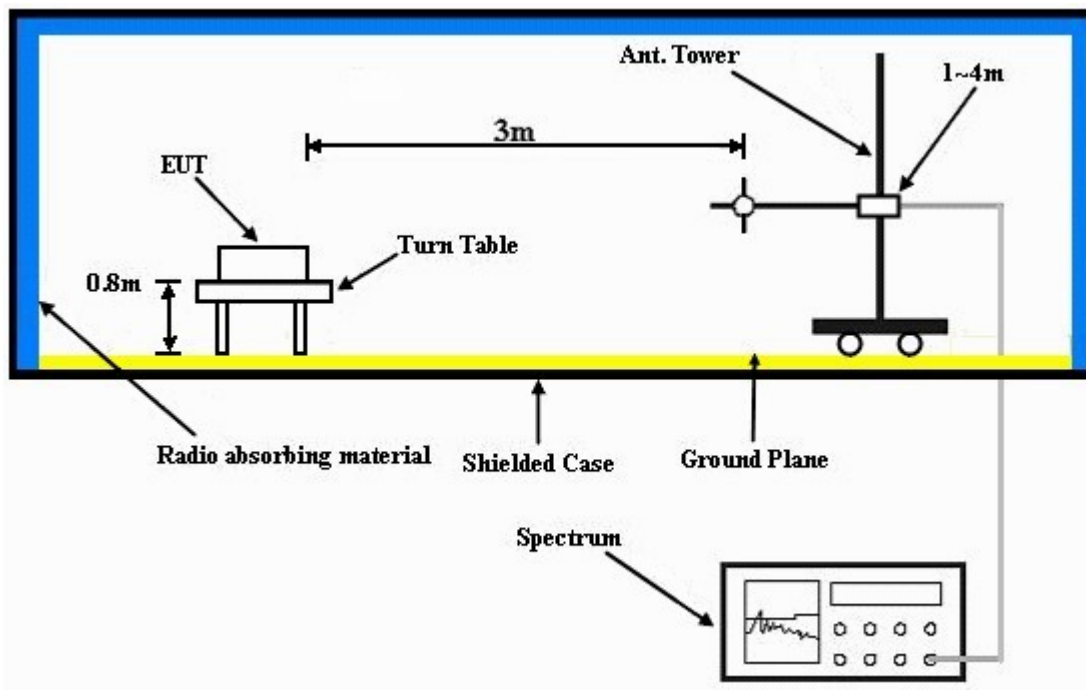

For the actual test configuration, please refer to the attached file (Test Setup Photo).

4.1.7 EUT OPERATING CONDITION

- a. Placed the EUT on the testing table.
- b. The EUT ran a test program (provided by manufacturer) to enable all functions under transmission condition continuously at specific channel frequency.



A D T

4.1.8 TEST RESULTS

ABOVE 1GHZ WORST-CASE DATA : TX (40MHz)

EUT TEST CONDITION		MEASUREMENT DETAIL	
CHANNEL / FREQUENCY	Channel 1 / 5190MHz	FREQUENCY RANGE	1 ~ 40GHz
INPUT POWER (SYSTEM)	120Vac, 60 Hz	DETECTOR FUNCTION	Peak (PK) Average (AV)
ENVIRONMENTAL CONDITIONS	25deg. C, 65%RH 1016 hPa	TESTED BY	Mark Liao

ANTENNA POLARITY & TEST DISTANCE: HORIZONTAL AT 3 M								
NO.	FREQ. (MHz)	EMISSION LEVEL (dBuV/m)	LIMIT (dBuV/m)	MARGIN (dB)	ANTENNA HEIGHT (m)	TABLE ANGLE (Degree)	RAW VALUE (dBuV)	CORRECTION FACTOR (dB/m)
1	5150.00	58.5 PK	74.0	-15.5	1.12 H	78	17.80	40.70
2	5150.00	45.9 AV	54.0	-8.1	1.12 H	78	5.20	40.70
3	*5190.00	109.4 PK			1.49 H	79	68.60	40.80
4	*5190.00	94.0 AV			1.49 H	79	53.20	40.80
5	#10380.00	61.8 PK	68.3	-6.5	1.40 H	325	9.90	51.90
ANTENNA POLARITY & TEST DISTANCE: VERTICAL AT 3 M								
NO.	FREQ. (MHz)	EMISSION LEVEL (dBuV/m)	LIMIT (dBuV/m)	MARGIN (dB)	ANTENNA HEIGHT (m)	TABLE ANGLE (Degree)	RAW VALUE (dBuV)	CORRECTION FACTOR (dB/m)
1	5150.00	55.9 PK	74.0	-18.1	1.14 V	258	15.20	40.70
2	5150.00	44.0 AV	54.0	-10.0	1.14 V	258	3.30	40.70
3	*5190.00	103.9 PK			1.13 V	259	63.10	40.80
4	*5190.00	90.5 AV			1.13 V	259	49.70	40.80
5	#10380.00	62.9 PK	68.3	-5.4	1.44 V	10	11.00	51.90

- REMARKS:**
1. Emission level (dBuV/m) = Raw Value (dBuV) + Correction Factor (dB/m).
 2. Correction Factor (dB/m) = Antenna Factor (dB/m) + Cable Factor (dB).
 3. The other emission levels were very low against the limit.
 4. Margin value = Emission level – Limit value.
 5. “ * “: Fundamental frequency.
 6. “#” :The radiated frequency is out the restricted band.



A D T

EUT TEST CONDITION		MEASUREMENT DETAIL	
CHANNEL / FREQUENCY	Channel 2 / 5230MHz	FREQUENCY RANGE	1 ~ 40GHz
INPUT POWER (SYSTEM)	120Vac, 60 Hz	DETECTOR FUNCTION	Peak (PK) Average (AV)
ENVIRONMENTAL CONDITIONS	25deg. C, 65%RH 1016 hPa	TESTED BY	Mark Liao

ANTENNA POLARITY & TEST DISTANCE: HORIZONTAL AT 3 M								
NO.	FREQ. (MHz)	EMISSION LEVEL (dBuV/m)	LIMIT (dBuV/m)	MARGIN (dB)	ANTENNA HEIGHT (m)	TABLE ANGLE (Degree)	RAW VALUE (dBuV)	CORRECTION FACTOR (dB/m)
1	*5230.00	107.3 PK			1.08 H	118	66.50	40.80
2	*5230.00	93.9 AV			1.08 H	118	53.10	40.80
3	5350.00	49.6 PK	74.0	-24.4	1.15 H	72	8.70	40.90
4	5350.00	38.7 AV	54.0	-15.3	1.15 H	72	-2.20	40.90
5	#10460.00	61.8 PK	68.3	-6.5	1.10 H	312	9.80	52.00
ANTENNA POLARITY & TEST DISTANCE: VERTICAL AT 3 M								
NO.	FREQ. (MHz)	EMISSION LEVEL (dBuV/m)	LIMIT (dBuV/m)	MARGIN (dB)	ANTENNA HEIGHT (m)	TABLE ANGLE (Degree)	RAW VALUE (dBuV)	CORRECTION FACTOR (dB/m)
1	*5230.00	103.9 PK			1.13 V	258	63.10	40.80
2	*5230.00	90.3 AV			1.13 V	258	49.50	40.80
3	5350.00	48.6 PK	74.0	-25.4	1.04 V	12	7.70	40.90
4	5350.00	37.9 AV	54.0	-16.1	1.04 V	12	-3.00	40.90
5	#10460.00	63.2 PK	68.3	-5.1	1.05 V	5	11.20	52.00

- REMARKS:**
1. Emission level (dBuV/m) = Raw Value (dBuV) + Correction Factor (dB/m).
 2. Correction Factor (dB/m) = Antenna Factor (dB/m) + Cable Factor (dB).
 3. The other emission levels were very low against the limit.
 4. Margin value = Emission level – Limit value.
 5. “ * “: Fundamental frequency.
 6. “#”:The radiated frequency is out the restricted band.



A D T

EUT TEST CONDITION		MEASUREMENT DETAIL	
CHANNEL / FREQUENCY	Channel 3 / 5270MHz	FREQUENCY RANGE	1 ~ 40GHz
INPUT POWER (SYSTEM)	120Vac, 60 Hz	DETECTOR FUNCTION	Peak (PK) Average (AV)
ENVIRONMENTAL CONDITIONS	25deg. C, 65%RH 1016 hPa	TESTED BY	Mark Liao

ANTENNA POLARITY & TEST DISTANCE: HORIZONTAL AT 3 M								
NO.	FREQ. (MHz)	EMISSION LEVEL (dBuV/m)	LIMIT (dBuV/m)	MARGIN (dB)	ANTENNA HEIGHT (m)	TABLE ANGLE (Degree)	RAW VALUE (dBuV)	CORRECTION FACTOR (dB/m)
1	5150.00	52.9 PK	74.0	-21.1	1.49 H	290	12.20	40.70
2	5150.00	39.7 AV	54.0	-14.3	1.49 H	290	-1.00	40.70
3	*5270.00	105.9 PK			1.49 H	290	65.10	40.80
4	*5270.00	92.2 AV			1.49 H	290	51.40	40.80
5	#10540.00	61.6 PK	68.3	-6.7	1.61 H	46	9.50	52.10
ANTENNA POLARITY & TEST DISTANCE: VERTICAL AT 3 M								
NO.	FREQ. (MHz)	EMISSION LEVEL (dBuV/m)	LIMIT (dBuV/m)	MARGIN (dB)	ANTENNA HEIGHT (m)	TABLE ANGLE (Degree)	RAW VALUE (dBuV)	CORRECTION FACTOR (dB/m)
1	5150.00	50.5 PK	74.0	-23.5	1.37 V	272	9.80	40.70
2	5150.00	37.6 AV	54.0	-16.4	1.37 V	272	-3.10	40.70
3	*5270.00	102.1 PK			1.37 V	272	61.30	40.80
4	*5270.00	89.9 AV			1.37 V	272	49.10	40.80
5	#10540.00	63.0 PK	68.3	-5.3	1.43 V	204	10.90	52.10

- REMARKS:**
1. Emission level (dBuV/m) = Raw Value (dBuV) + Correction Factor (dB/m).
 2. Correction Factor (dB/m) = Antenna Factor (dB/m) + Cable Factor (dB).
 3. The other emission levels were very low against the limit.
 4. Margin value = Emission level – Limit value.
 5. “ * “: Fundamental frequency.
 6. “#”:The radiated frequency is out the restricted band.



A D T

EUT TEST CONDITION		MEASUREMENT DETAIL	
CHANNEL / FREQUENCY	Channel 4 / 5310MHz	FREQUENCY RANGE	1 ~ 40GHz
INPUT POWER (SYSTEM)	120Vac, 60 Hz	DETECTOR FUNCTION	Peak (PK) Average (AV)
ENVIRONMENTAL CONDITIONS	25deg. C, 65%RH 1016 hPa	TESTED BY	Mark Liao

ANTENNA POLARITY & TEST DISTANCE: HORIZONTAL AT 3 M								
NO.	FREQ. (MHz)	EMISSION LEVEL (dBuV/m)	LIMIT (dBuV/m)	MARGIN (dB)	ANTENNA HEIGHT (m)	TABLE ANGLE (Degree)	RAW VALUE (dBuV)	CORRECTION FACTOR (dB/m)
1	*5310.00	107.0 PK			1.48 H	281	66.10	40.90
2	*5310.00	93.4 AV			1.48 H	281	52.50	40.90
3	5350.00	57.2 PK	74.0	-16.8	1.42 H	159	16.30	40.90
4	5350.00	45.1 AV	54.0	-8.9	1.42 H	159	4.20	40.90
5	10620.00	61.7 PK	74.0	-12.3	1.52 H	133	9.40	52.30
6	10620.00	49.3 AV	54.0	-4.7	1.52 H	133	-3.00	52.30
ANTENNA POLARITY & TEST DISTANCE: VERTICAL AT 3 M								
NO.	FREQ. (MHz)	EMISSION LEVEL (dBuV/m)	LIMIT (dBuV/m)	MARGIN (dB)	ANTENNA HEIGHT (m)	TABLE ANGLE (Degree)	RAW VALUE (dBuV)	CORRECTION FACTOR (dB/m)
1	*5310.00	104.9 PK			1.35 V	199	64.00	40.90
2	*5310.00	90.9 AV			1.35 V	199	50.00	40.90
3	5350.00	55.8 PK	74.0	-18.2	1.33 V	219	14.90	40.90
4	5350.00	44.0 AV	54.0	-10.0	1.33 V	219	3.10	40.90
5	10620.00	63.2 PK	74.0	-10.8	1.41 V	167	10.90	52.30
6	10620.00	52.9 AV	54.0	-1.1	1.41 V	167	0.60	52.30

- REMARKS:**
1. Emission level (dBuV/m) = Raw Value (dBuV) + Correction Factor (dB/m).
 2. Correction Factor (dB/m) = Antenna Factor (dB/m) + Cable Factor (dB).
 3. The other emission levels were very low against the limit.
 4. Margin value = Emission level – Limit value.
 5. “ * “: Fundamental frequency.



A D T

EUT TEST CONDITION		MEASUREMENT DETAIL	
CHANNEL / FREQUENCY	Channel 5 / 5510MHz	FREQUENCY RANGE	1 ~ 40GHz
INPUT POWER (SYSTEM)	120Vac, 60 Hz	DETECTOR FUNCTION	Peak (PK) Average (AV)
ENVIRONMENTAL CONDITIONS	25deg. C, 65%RH 1016 hPa	TESTED BY	Mark Liao

ANTENNA POLARITY & TEST DISTANCE: HORIZONTAL AT 3 M								
NO.	FREQ. (MHz)	EMISSION LEVEL (dBuV/m)	LIMIT (dBuV/m)	MARGIN (dB)	ANTENNA HEIGHT (m)	TABLE ANGLE (Degree)	RAW VALUE (dBuV)	CORRECTION FACTOR (dB/m)
1	5460.00	57.2 PK	74.0	-16.8	1.10 H	129	16.10	41.10
2	5460.00	41.1 AV	54.0	-12.9	1.10 H	129	0.00	41.10
3	#5470.00	61.9 PK	68.3	-6.4	1.10 H	129	20.80	41.10
4	*5510.00	106.2 PK			1.05 H	311	65.00	41.20
5	*5510.00	93.0 AV			1.05 H	311	51.80	41.20
6	11020.00	60.9 PK	74.0	-13.1	1.16 H	93	7.90	53.00
7	11020.00	50.0 AV	54.0	-4.0	1.16 H	93	-3.00	53.00

ANTENNA POLARITY & TEST DISTANCE: VERTICAL AT 3 M								
NO.	FREQ. (MHz)	EMISSION LEVEL (dBuV/m)	LIMIT (dBuV/m)	MARGIN (dB)	ANTENNA HEIGHT (m)	TABLE ANGLE (Degree)	RAW VALUE (dBuV)	CORRECTION FACTOR (dB/m)
1	5460.00	55.7 PK	74.0	-18.3	1.42 V	154	14.60	41.10
2	5460.00	39.4 AV	54.0	-14.6	1.42 V	154	-1.70	41.10
3	#5470.00	58.5 PK	68.3	-9.8	1.42 V	154	17.40	41.10
4	*5510.00	104.5 PK			1.42 V	151	63.30	41.20
5	*5510.00	91.0 AV			1.42 V	151	49.80	41.20
6	11020.00	62.5 PK	74.0	-11.5	1.72 V	204	9.50	53.00
7	11020.00	51.2 AV	54.0	-2.8	1.72 V	204	-1.80	53.00

- REMARKS:**
1. Emission level (dBuV/m) = Raw Value (dBuV) + Correction Factor (dB/m).
 2. Correction Factor (dB/m) = Antenna Factor (dB/m) + Cable Factor (dB).
 3. The other emission levels were very low against the limit.
 4. Margin value = Emission level – Limit value.
 5. “ * “: Fundamental frequency.
 6. “#”:The radiated frequency is out the restricted band.



A D T

EUT TEST CONDITION		MEASUREMENT DETAIL	
CHANNEL / FREQUENCY	Channel 6 / 5550MHz	FREQUENCY RANGE	1 ~ 40GHz
INPUT POWER (SYSTEM)	120Vac, 60 Hz	DETECTOR FUNCTION	Peak (PK) Average (AV)
ENVIRONMENTAL CONDITIONS	25deg. C, 65%RH 1016 hPa	TESTED BY	Mark Liao

ANTENNA POLARITY & TEST DISTANCE: HORIZONTAL AT 3 M								
NO.	FREQ. (MHz)	EMISSION LEVEL (dBuV/m)	LIMIT (dBuV/m)	MARGIN (dB)	ANTENNA HEIGHT (m)	TABLE ANGLE (Degree)	RAW VALUE (dBuV)	CORRECTION FACTOR (dB/m)
1	*5550.00	105.3 PK			1.03 H	328	64.10	41.20
2	*5550.00	91.5 AV			1.03 H	328	50.30	41.20
3	#5600.00	60.1 PK	68.30	-8.2	1.06 H	251	18.90	41.30
4	11100.00	64.2 PK	74.00	-9.8	1.10 H	84	11.10	53.10
5	11100.00	50.8 AV	54.00	-3.2	1.10 H	84	-2.30	53.10
ANTENNA POLARITY & TEST DISTANCE: VERTICAL AT 3 M								
NO.	FREQ. (MHz)	EMISSION LEVEL (dBuV/m)	LIMIT (dBuV/m)	MARGIN (dB)	ANTENNA HEIGHT (m)	TABLE ANGLE (Degree)	RAW VALUE (dBuV)	CORRECTION FACTOR (dB/m)
1	*5550.00	103.3 PK			1.26 V	154	62.10	41.20
2	*5550.00	90.1 AV			1.26 V	154	48.90	41.20
3	#5600.00	58.0 PK	68.30	-10.3	1.22 V	193	16.70	41.30
4	11100.00	64.2 PK	74.00	-9.8	1.26 V	216	11.10	53.10
5	11100.00	52.1 AV	54.00	-1.9	1.26 V	216	-1.00	53.10

- REMARKS:**
1. Emission level (dBuV/m) = Raw Value (dBuV) + Correction Factor (dB/m).
 2. Correction Factor (dB/m) = Antenna Factor (dB/m) + Cable Factor (dB).
 3. The other emission levels were very low against the limit.
 4. Margin value = Emission level – Limit value.
 5. “ * “: Fundamental frequency.
 6. “#”:The radiated frequency is out the restricted band.



A D T

BELOW 1GHz WORST-CASE DATA : TX (40MHz)

EUT TEST CONDITION		MEASUREMENT DETAIL	
CHANNEL / FREQUENCY	Channel 1 / 5190MHz	FREQUENCY RANGE	Below 1000MHz
INPUT POWER (SYSTEM)	120Vac, 60 Hz	DETECTOR FUNCTION	Quasi-Peak
ENVIRONMENTAL CONDITIONS	25deg. C, 65%RH 1017 hPa	TESTED BY	Mark Liao

ANTENNA POLARITY & TEST DISTANCE: HORIZONTAL AT 3 M

NO.	FREQ. (MHz)	EMISSION LEVEL (dBuV/m)	LIMIT (dBuV/m)	MARGIN (dB)	ANTENNA HEIGHT (m)	TABLE ANGLE (Degree)	RAW VALUE (dBuV)	CORRECTION FACTOR (dB/m)
1	33.79	17.1 QP	40.0	-22.9	1.00 H	292	4.30	12.80
2	226.27	17.9 QP	46.0	-28.1	1.50 H	259	5.50	12.40
3	479.03	20.5 QP	46.0	-25.5	1.50 H	328	0.30	20.20
4	605.41	23.8 QP	46.0	-22.2	1.50 H	88	0.60	23.20
5	753.18	25.7 QP	46.0	-20.3	1.25 H	241	0.10	25.60
6	893.16	27.0 QP	46.0	-19.0	1.00 H	10	-1.20	28.20

ANTENNA POLARITY & TEST DISTANCE: VERTICAL AT 3 M

NO.	FREQ. (MHz)	EMISSION LEVEL (dBuV/m)	LIMIT (dBuV/m)	MARGIN (dB)	ANTENNA HEIGHT (m)	TABLE ANGLE (Degree)	RAW VALUE (dBuV)	CORRECTION FACTOR (dB/m)
1	31.84	21.6 QP	40.0	-18.4	1.25 V	316	8.80	12.80
2	224.33	17.3 QP	46.0	-28.7	1.00 V	124	4.90	12.40
3	319.60	20.6 QP	46.0	-25.4	1.50 V	235	4.50	16.10
4	479.03	24.8 QP	46.0	-21.2	1.00 V	238	4.60	20.20
5	794.01	25.9 QP	46.0	-20.1	1.50 V	106	-0.40	26.30
6	945.66	30.7 QP	46.0	-15.3	1.25 V	37	2.00	28.70

- REMARKS:**
1. Emission level (dBuV/m) = Raw Value (dBuV) + Correction Factor (dB/m).
 2. Correction Factor (dB/m) = Antenna Factor (dB/m) + Cable Factor (dB).
 3. The other emission levels were very low against the limit.
 4. Margin value = Emission level – Limit value.



A D T

EUT TEST CONDITION		MEASUREMENT DETAIL	
CHANNEL / FREQUENCY	Channel 4 / 5310MHz	FREQUENCY RANGE	Below 1000MHz
INPUT POWER (SYSTEM)	120Vac, 60 Hz	DETECTOR FUNCTION	Quasi-Peak
ENVIRONMENTAL CONDITIONS	25deg. C, 65%RH 1017 hPa	TESTED BY	Mark Liao

ANTENNA POLARITY & TEST DISTANCE: HORIZONTAL AT 3 M								
NO.	FREQ. (MHz)	EMISSION LEVEL (dBuV/m)	LIMIT (dBuV/m)	MARGIN (dB)	ANTENNA HEIGHT (m)	TABLE ANGLE (Degree)	RAW VALUE (dBuV)	CORRECTION FACTOR (dB/m)
1	226.27	16.9 QP	46.0	-29.1	1.25 H	244	4.50	12.40
2	302.10	20.1 QP	46.0	-25.9	1.00 H	277	4.50	15.60
3	492.64	21.6 QP	46.0	-24.4	1.25 H	136	1.00	20.60
4	611.24	22.6 QP	46.0	-23.4	1.25 H	271	-0.70	23.30
5	741.51	24.9 QP	46.0	-21.1	1.00 H	10	-0.40	25.30
6	858.17	27.2 QP	46.0	-18.8	1.00 H	187	-0.40	27.60

ANTENNA POLARITY & TEST DISTANCE: VERTICAL AT 3 M								
NO.	FREQ. (MHz)	EMISSION LEVEL (dBuV/m)	LIMIT (dBuV/m)	MARGIN (dB)	ANTENNA HEIGHT (m)	TABLE ANGLE (Degree)	RAW VALUE (dBuV)	CORRECTION FACTOR (dB/m)
1	31.84	23.8 QP	40.0	-16.2	1.25 V	43	11.00	12.80
2	226.27	17.4 QP	46.0	-28.6	1.00 V	115	5.00	12.40
3	331.26	18.6 QP	46.0	-27.4	1.25 V	100	2.30	16.30
4	480.97	23.7 QP	46.0	-22.3	1.25 V	238	3.40	20.30
5	731.79	24.3 QP	46.0	-21.7	1.25 V	193	-0.80	25.10
6	883.44	27.1 QP	46.0	-18.9	1.00 V	274	-0.90	28.00

- REMARKS:**
1. Emission level (dBuV/m) = Raw Value (dBuV) + Correction Factor (dB/m).
 2. Correction Factor (dB/m) = Antenna Factor (dB/m) + Cable Factor (dB).
 3. The other emission levels were very low against the limit.
 4. Margin value = Emission level – Limit value.



A D T

EUT TEST CONDITION		MEASUREMENT DETAIL	
CHANNEL / FREQUENCY	Channel 5 / 5510MHz	FREQUENCY RANGE	Below 1000MHz
INPUT POWER (SYSTEM)	120Vac, 60 Hz	DETECTOR FUNCTION	Quasi-Peak
ENVIRONMENTAL CONDITIONS	25deg. C, 65%RH 1017 hPa	TESTED BY	Mark Liao

ANTENNA POLARITY & TEST DISTANCE: HORIZONTAL AT 3 M								
NO.	FREQ. (MHz)	EMISSION LEVEL (dBuV/m)	LIMIT (dBuV/m)	MARGIN (dB)	ANTENNA HEIGHT (m)	TABLE ANGLE (Degree)	RAW VALUE (dBuV)	CORRECTION FACTOR (dB/m)
1	226.27	16.9 QP	46.0	-29.1	1.00 H	271	4.50	12.40
2	276.82	19.4 QP	46.0	-26.6	1.00 H	259	4.90	14.50
3	601.52	21.9 QP	46.0	-24.1	1.25 H	205	-1.30	23.20
4	638.46	24.2 QP	46.0	-21.8	1.00 H	325	0.50	23.70
5	799.84	26.0 QP	46.0	-20.0	1.00 H	274	-0.40	26.40
6	879.55	27.1 QP	46.0	-18.9	1.00 H	88	-0.80	27.90
ANTENNA POLARITY & TEST DISTANCE: VERTICAL AT 3 M								
NO.	FREQ. (MHz)	EMISSION LEVEL (dBuV/m)	LIMIT (dBuV/m)	MARGIN (dB)	ANTENNA HEIGHT (m)	TABLE ANGLE (Degree)	RAW VALUE (dBuV)	CORRECTION FACTOR (dB/m)
1	31.84	21.8 QP	40.0	-18.2	1.25 V	19	9.00	12.80
2	224.33	16.6 QP	46.0	-29.4	1.00 V	94	4.20	12.40
3	319.60	19.5 QP	46.0	-26.5	1.25 V	217	3.40	16.10
4	580.13	22.2 QP	46.0	-23.8	1.25 V	10	-0.50	22.70
5	716.23	24.8 QP	46.0	-21.2	1.00 V	10	0.00	24.80
6	865.94	26.6 QP	46.0	-19.4	1.25 V	10	-1.10	27.70

- REMARKS:**
1. Emission level (dBuV/m) = Raw Value (dBuV) + Correction Factor (dB/m).
 2. Correction Factor (dB/m) = Antenna Factor (dB/m) + Cable Factor (dB).
 3. The other emission levels were very low against the limit.
 4. Margin value = Emission level – Limit value.

4.2 CONDUCTED EMISSION MEASUREMENT

4.2.1 LIMITS OF CONDUCTED EMISSION MEASUREMENT

FREQUENCY OF EMISSION (MHz)	CONDUCTED LIMIT (dB μ V)	
	Quasi-peak	Average
0.15 ~ 0.5	66 to 56	56 to 46
0.5 ~ 5	56	46
5 ~ 30	60	50

- NOTE:**
1. The lower limit shall apply at the transition frequencies.
 2. The limit decreases in line with the logarithm of the frequency in the range of 0.15 to 0.50MHz.
 3. All emanations from a class A/B digital device or system, including any network of conductors and apparatus connected thereto, shall not exceed the level of field strengths specified above.

4.2.2 TEST INSTRUMENTS

DESCRIPTION & MANUFACTURER	MODEL NO.	SERIAL NO.	DATE OF CALIBRATION	DUE DATE OF CALIBRATION
Test Receiver ROHDE & SCHWARZ	ESCS30	100291	Dec. 16, 2009	Dec. 15, 2010
RF signal cable Woken	5D-FB	Cable-HYC01-01	Nov. 12, 2009	Nov. 11, 2010
LISN ROHDE & SCHWARZ	ESH3-Z5	100312	Jun. 18, 2009	Jun. 17, 2010
LISN ROHDE & SCHWARZ	ESH3-Z5	835239/001	Feb. 24, 2009	Feb. 23, 2010
Software ADT	ADT_Cond_ V7.3.7	NA	NA	NA

- NOTE:**
1. The calibration interval of the above test instruments is 12 months and the calibrations are traceable to NML/ROC and NIST/USA.
 2. The test was performed in HwaYa Shielded Room 1.
 3. The VCCI Site Registration No. is C-2040.

4.2.3 TEST PROCEDURES

- a. The EUT was placed 0.4 meters from the conducting wall of the shielded room with EUT being connected to the power mains through a line impedance stabilization network (LISN). Other support units were connected to the power mains through another LISN. The two LISNs provide 50 ohm/ 50uH of coupling impedance for the measuring instrument.
- b. Both lines of the power mains connected to the EUT were checked for maximum conducted interference.
- c. The frequency range from 150kHz to 30MHz was searched. Emission levels under (Limit - 20dB) was not recorded.

NOTE: All modes of operation were investigated and the worst-case emissions are reported.

4.2.4 DEVIATION FROM TEST STANDARD

No deviation.

4.2.5 TEST SETUP

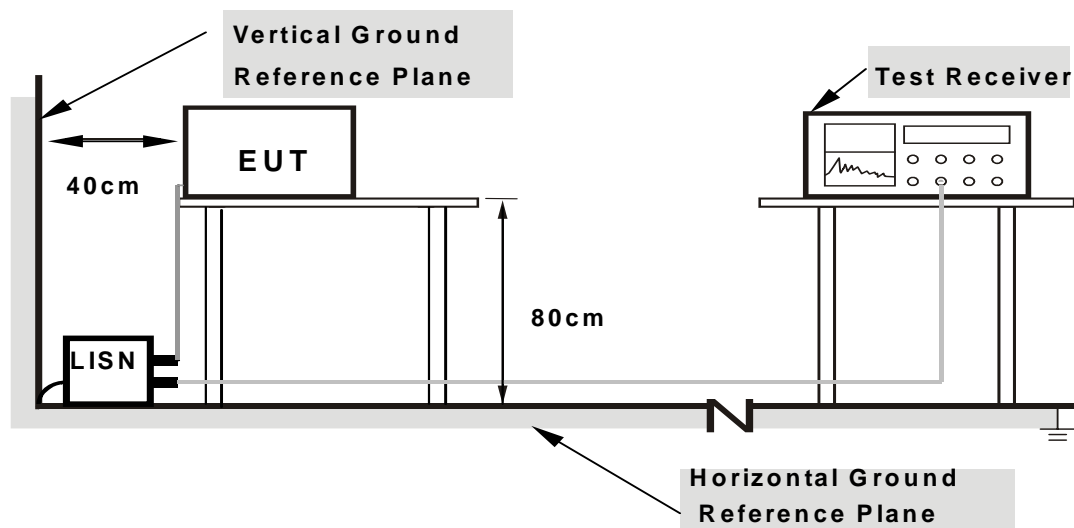

Note: 1. Support units were connected to second LISN.

2. Both of LISNs (AMN) are 80 cm from EUT and at least 80 from other units and other metal planes

For the actual test configuration, please refer to the attached file (Test Setup Photo).

4.2.6 EUT OPERATING CONDITIONS

Same as 4.1.6.



A D T

4.2.7 TEST RESULTS

CONDUCTED WORST-CASE DATA : TX (40MHz)

PHASE	Line 1	6dB BANDWIDTH	9kHz
CHANNEL / FREQUENCY	Channel 1 / 5190MHz		

No	Freq. [MHz]	Corr. Factor (dB)	Reading Value		Emission Level		Limit		Margin	
			[dB (uV)]		[dB (uV)]		[dB (uV)]		(dB)	
			Q.P.	AV.	Q.P.	AV.	Q.P.	AV.	Q.P.	AV.
1	0.177	0.13	36.74	-	36.87	-	64.61	54.61	-27.74	-
2	0.205	0.13	37.16	-	37.29	-	63.42	53.42	-26.13	-
3	0.236	0.13	26.42	-	26.55	-	62.24	52.24	-35.69	-
4	0.310	0.14	16.05	-	16.19	-	59.97	49.97	-43.78	-
5	0.420	0.14	12.96	-	13.10	-	57.46	47.46	-44.36	-
6	21.231	1.41	31.33	-	32.74	-	60.00	50.00	-27.26	-

- REMARKS:**
1. Q.P. and AV. are abbreviations of quasi-peak and average individually.
 2. "-": The Quasi-peak reading value also meets average limit and measurement with the average detector is unnecessary.
 3. The emission levels of other frequencies were very low against the limit.
 4. Margin value = Emission level - Limit value
 5. Correction factor = Insertion loss + Cable loss
 6. Emission Level = Correction Factor + Reading Value.

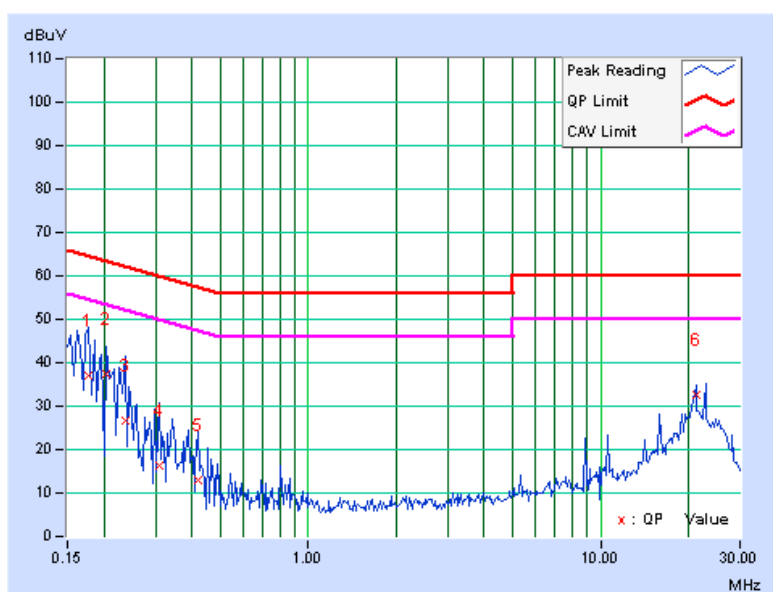



A D T

PHASE	Line 2	6dB BANDWIDTH	9kHz
CHANNEL / FREQUENCY	Channel 1 / 5190MHz		

No	Freq. [MHz]	Corr. Factor (dB)	Reading Value		Emission Level		Limit		Margin	
			[dB (uV)]		[dB (uV)]		[dB (uV)]		(dB)	
			Q.P.	AV.	Q.P.	AV.	Q.P.	AV.	Q.P.	AV.
1	0.170	0.09	37.00	-	37.09	-	64.98	54.98	-27.89	-
2	0.205	0.09	34.70	-	34.79	-	63.42	53.42	-28.63	-
3	0.252	0.09	22.28	-	22.37	-	61.71	51.71	-39.33	-
4	0.306	0.10	17.39	-	17.49	-	60.07	50.07	-42.59	-
5	0.377	0.10	13.09	-	13.19	-	58.35	48.35	-45.17	-
6	21.212	0.96	36.56	-	37.52	-	60.00	50.00	-22.48	-

- REMARKS:**
1. Q.P. and AV. are abbreviations of quasi-peak and average individually.
 2. "-": The Quasi-peak reading value also meets average limit and measurement with the average detector is unnecessary.
 3. The emission levels of other frequencies were very low against the limit.
 4. Margin value = Emission level - Limit value
 5. Correction factor = Insertion loss + Cable loss
 6. Emission Level = Correction Factor + Reading Value.

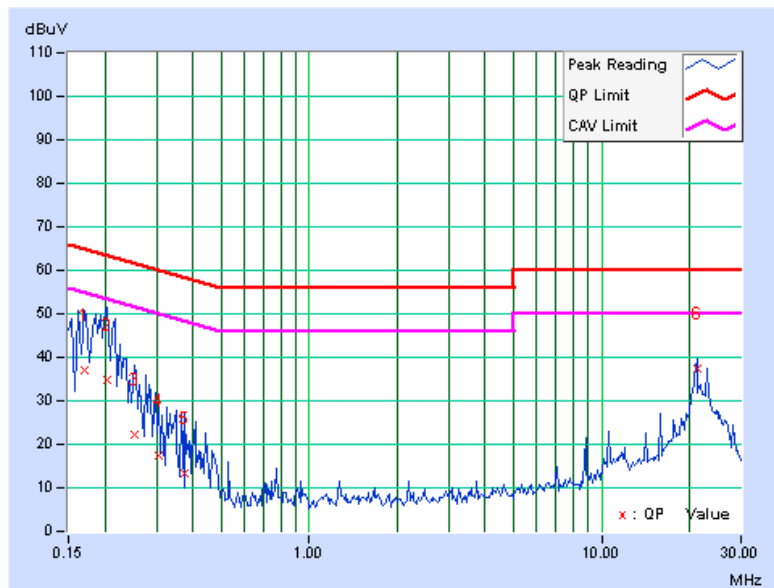



A D T

PHASE	Line 1	6dB BANDWIDTH	9kHz
CHANNEL / FREQUENCY	Channel 4 / 5310MHz		

No	Freq. [MHz]	Corr. Factor (dB)	Reading Value		Emission Level		Limit		Margin	
			[dB (uV)]		[dB (uV)]		[dB (uV)]		(dB)	
			Q.P.	AV.	Q.P.	AV.	Q.P.	AV.	Q.P.	AV.
1	0.150	0.13	36.03	-	36.16	-	66.00	56.00	-29.84	-
2	0.177	0.13	38.98	-	39.11	-	64.61	54.61	-25.50	-
3	0.209	0.13	34.81	-	34.94	-	63.26	53.26	-28.32	-
4	0.236	0.13	28.46	-	28.59	-	62.24	52.24	-33.65	-
5	0.287	0.13	18.45	-	18.58	-	60.62	50.62	-42.03	-
6	21.210	1.41	31.13	-	32.54	-	60.00	50.00	-27.46	-

- REMARKS:**
1. Q.P. and AV. are abbreviations of quasi-peak and average individually.
 2. "-": The Quasi-peak reading value also meets average limit and measurement with the average detector is unnecessary.
 3. The emission levels of other frequencies were very low against the limit.
 4. Margin value = Emission level - Limit value
 5. Correction factor = Insertion loss + Cable loss
 6. Emission Level = Correction Factor + Reading Value.

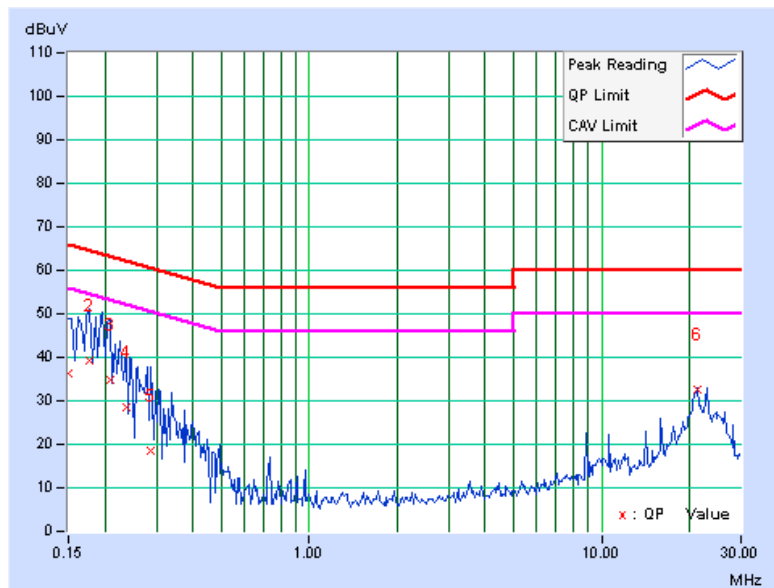



A D T

PHASE	Line 2	6dB BANDWIDTH	9kHz
CHANNEL / FREQUENCY	Channel 4 / 5310MHz		

No	Freq. [MHz]	Corr. Factor (dB)	Reading Value [dB (uV)]		Emission Level [dB (uV)]		Limit [dB (uV)]		Margin (dB)	
			Q.P.	AV.	Q.P.	AV.	Q.P.	AV.	Q.P.	AV.
1	0.162	0.09	36.79	-	36.88	-	65.38	55.38	-28.50	-
2	0.181	0.09	39.20	-	39.29	-	64.43	54.43	-25.14	-
3	0.244	0.09	26.13	-	26.22	-	61.97	51.97	-35.75	-
4	0.295	0.09	17.52	-	17.61	-	60.40	50.40	-42.78	-
5	0.353	0.10	14.16	-	14.26	-	58.89	48.89	-44.63	-
6	21.211	0.96	35.95	-	36.91	-	60.00	50.00	-23.09	-

- REMARKS:**
1. Q.P. and AV. are abbreviations of quasi-peak and average individually.
 2. "-": The Quasi-peak reading value also meets average limit and measurement with the average detector is unnecessary.
 3. The emission levels of other frequencies were very low against the limit.
 4. Margin value = Emission level - Limit value
 5. Correction factor = Insertion loss + Cable loss
 6. Emission Level = Correction Factor + Reading Value.

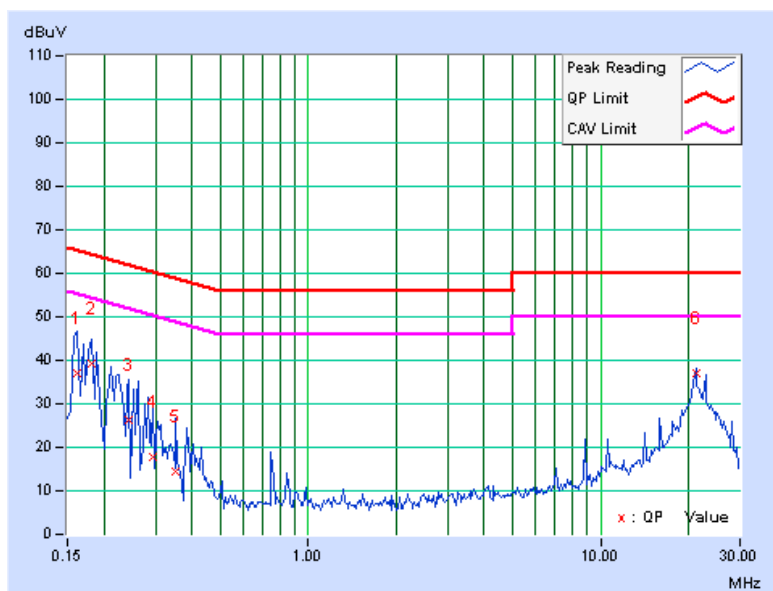



A D T

PHASE	Line 1	6dB BANDWIDTH	9kHz
CHANNEL / FREQUENCY	Channel 5 / 5510MHz		

No	Freq. [MHz]	Corr. Factor (dB)	Reading Value		Emission Level		Limit		Margin	
			[dB (uV)]		[dB (uV)]		[dB (uV)]		(dB)	
			Q.P.	AV.	Q.P.	AV.	Q.P.	AV.	Q.P.	AV.
1	0.158	0.13	35.87	-	36.00	-	65.58	55.58	-29.58	-
2	0.181	0.13	38.50	-	38.63	-	64.43	54.43	-25.80	-
3	0.228	0.13	29.70	-	29.83	-	62.52	52.52	-32.69	-
4	0.275	0.13	20.07	-	20.20	-	60.97	50.97	-40.76	-
5	0.341	0.14	14.61	-	14.75	-	59.17	49.17	-44.42	-
6	21.207	1.41	30.38	-	31.79	-	60.00	50.00	-28.21	-

- REMARKS:**
1. Q.P. and AV. are abbreviations of quasi-peak and average individually.
 2. "-": The Quasi-peak reading value also meets average limit and measurement with the average detector is unnecessary.
 3. The emission levels of other frequencies were very low against the limit.
 4. Margin value = Emission level - Limit value
 5. Correction factor = Insertion loss + Cable loss
 6. Emission Level = Correction Factor + Reading Value.

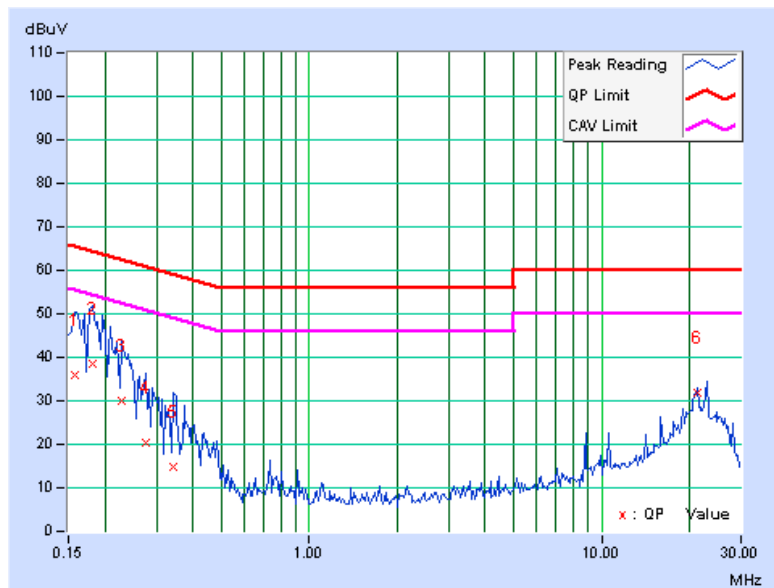



A D T

PHASE	Line 2	6dB BANDWIDTH	9kHz
CHANNEL / FREQUENCY	Channel 5 / 5510MHz		

No	Freq. [MHz]	Corr. Factor (dB)	Reading Value [dB (uV)]		Emission Level [dB (uV)]		Limit [dB (uV)]		Margin (dB)	
			Q.P.	AV.	Q.P.	AV.	Q.P.	AV.	Q.P.	AV.
1	0.166	0.09	37.48	-	37.57	-	65.18	55.18	-27.61	-
2	0.209	0.09	35.90	-	35.99	-	63.26	53.26	-27.27	-
3	0.263	0.09	23.54	-	23.63	-	61.33	51.33	-37.69	-
4	0.291	0.09	19.03	-	19.12	-	60.51	50.51	-41.38	-
5	0.365	0.10	13.21	-	13.31	-	58.62	48.62	-45.31	-
6	21.207	0.96	36.22	-	37.18	-	60.00	50.00	-22.82	-

- REMARKS:**
1. Q.P. and AV. are abbreviations of quasi-peak and average individually.
 2. "-": The Quasi-peak reading value also meets average limit and measurement with the average detector is unnecessary.
 3. The emission levels of other frequencies were very low against the limit.
 4. Margin value = Emission level - Limit value
 5. Correction factor = Insertion loss + Cable loss
 6. Emission Level = Correction Factor + Reading Value.

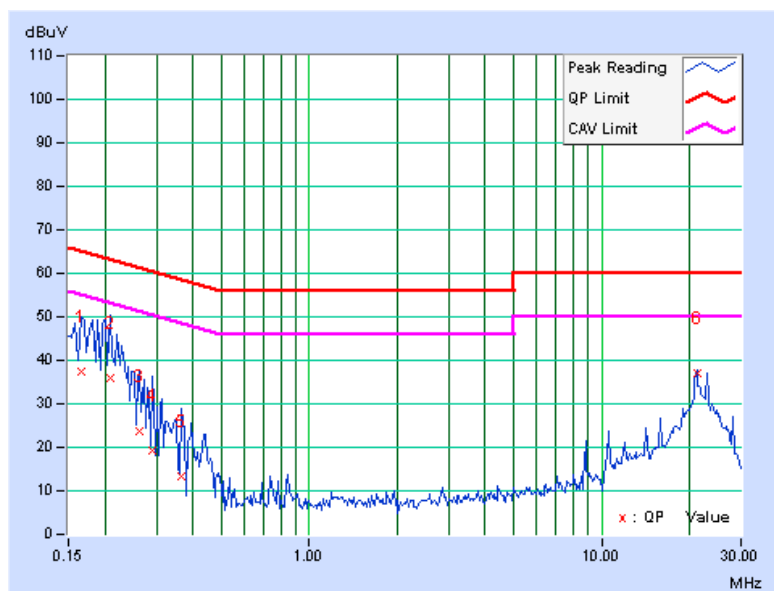



A D T

4.3 MAXIMUM CONDUCTED OUTPUT POWER MEASUREMENT

4.3.1 LIMITS OF MAXIMUM CONDUCTED OUTPUT POWER MEASUREMENT

FREQUENCY BAND	LIMIT
5.150 ~ 5.250GHz	The lesser of 50mW (17dBm) or 4dBm + 10logB
5.250 ~ 5.350GHz	The lesser of 250mW (24dBm) or 11dBm + 10logB
5.470 ~ 5.725GHz	The lesser of 250mW (24dBm) or 11dBm + 10logB

NOTE: Where B is the 26dB emission bandwidth in MHz.

4.3.2 TEST INSTRUMENTS

FOR POWER OUTPUT MEASUREMENT

DESCRIPTION & MANUFACTURER	MODEL NO.	SERIAL NO.	DATE OF CALIBRATION	CALIBRATED UNTIL
High Speed Peak Power Meter	ML2495A	0824012	Aug. 10, 2009	Aug. 09, 2010
Power Sensor	MA2411B	0738138	Aug. 10, 2009	Aug. 09, 2010

NOTE:

1. The calibration interval of the above test instruments is 12 months and the calibrations are traceable to NML/ROC and NIST/USA.
2. Measurement Bandwidth of ML2495A is 65MHz greater than 26dB bandwidth of emission.

FOR 26dB OCCUPIED BANDWIDTH

DESCRIPTION & MANUFACTURER	MODEL NO.	SERIAL NO.	DATE OF CALIBRATION	DUE DATE OF CALIBRATION
SPECTRUM ANALYZER R&S	FSP40	100040	Jul. 07, 2009	Jul. 06, 2010

NOTE: The calibration interval of the above test instruments is 12 months and the calibrations are traceable to NML/ROC and NIST/USA.

4.3.3 TEST PROCEDURES

FOR POWER OUTPUT MEASUREMENT

A power sensor was used on the output port of the EUT. A power meter was used to read the response of the power sensor. Record the power level.

FOR 26dB OCCUPIED BANDWIDTH

The transmitter output was connected to the spectrum analyzer through an attenuator. The bandwidth of the fundamental frequency was measured by spectrum analyzer with 300kHz RBW and 1MHz VBW. The 26dB bandwidth is defined as the total spectrum the power of which is higher than peak power minus 26dB.

4.3.4 DEVIATION FROM TEST STANDARD

No deviation.

4.3.5 TEST SETUP

FOR POWER OUTPUT MEASUREMENT

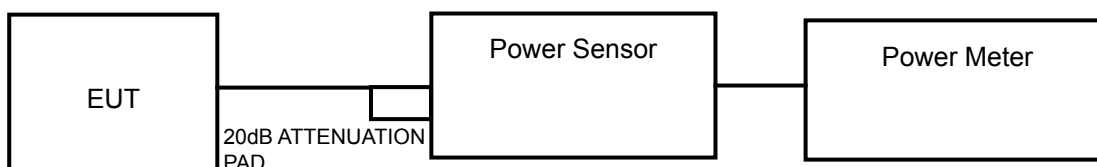

FOR 26dB OCCUPIED BANDWIDTH

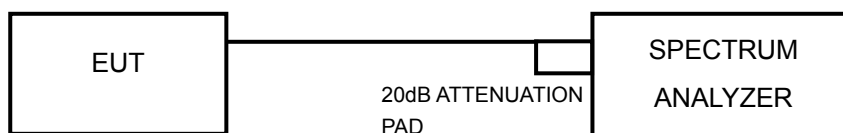

4.3.6 EUT OPERATING CONDITIONS

The software provided by client to enable the EUT under transmission condition continuously at specific channel frequencies individually.



A D T

4.3.7 TEST RESULTS

POWER OUTPUT: TX (40MHz)

CHAN.	CHAN. FREQ. (MHz)	POWER OUTPUT (dBm)				TOTAL POWER (mW)	TOTAL POWER (dBm)	POWER LIMIT (dBm)	PASS / FAIL
		CHAIN 0	CHAIN 1	CHAIN 2	CHAIN 3				
1	5190	10.6	10.5	10.6	10.4	45.1	16.5	17	PASS
2	5230	10.5	10.4	10.4	10.1	43.4	16.4	17	PASS
3	5270	10.6	10.4	10.3	10.4	44.1	16.4	24	PASS
4	5310	10.2	10.5	10.6	10.5	44.4	16.5	24	PASS
5	5510	10.2	10.3	10.5	10.5	43.6	16.4	24	PASS
6	5550	10.3	10.2	10.4	10.4	43.1	16.3	24	PASS



A D T

26dB OCCUPIED BANDWIDTH: TX (40MHz)

CHANNEL	CHANNEL FREQUENCY (MHz)	26dBc OCCUPIED BANDWIDTH (MHz)				PASS / FAIL
		CHAIN 0	CHAIN 1	CHAIN 2	CHAIN 3	
1	5190	41.57	39.70	39.50	39.52	PASS
2	5230	39.76	39.85	39.35	39.46	PASS
3	5270	39.63	39.61	39.52	39.29	PASS
4	5310	39.54	39.48	39.34	39.27	PASS
5	5510	39.55	39.50	39.49	39.47	PASS
6	5550	39.65	39.51	39.52	39.32	PASS

CH 1

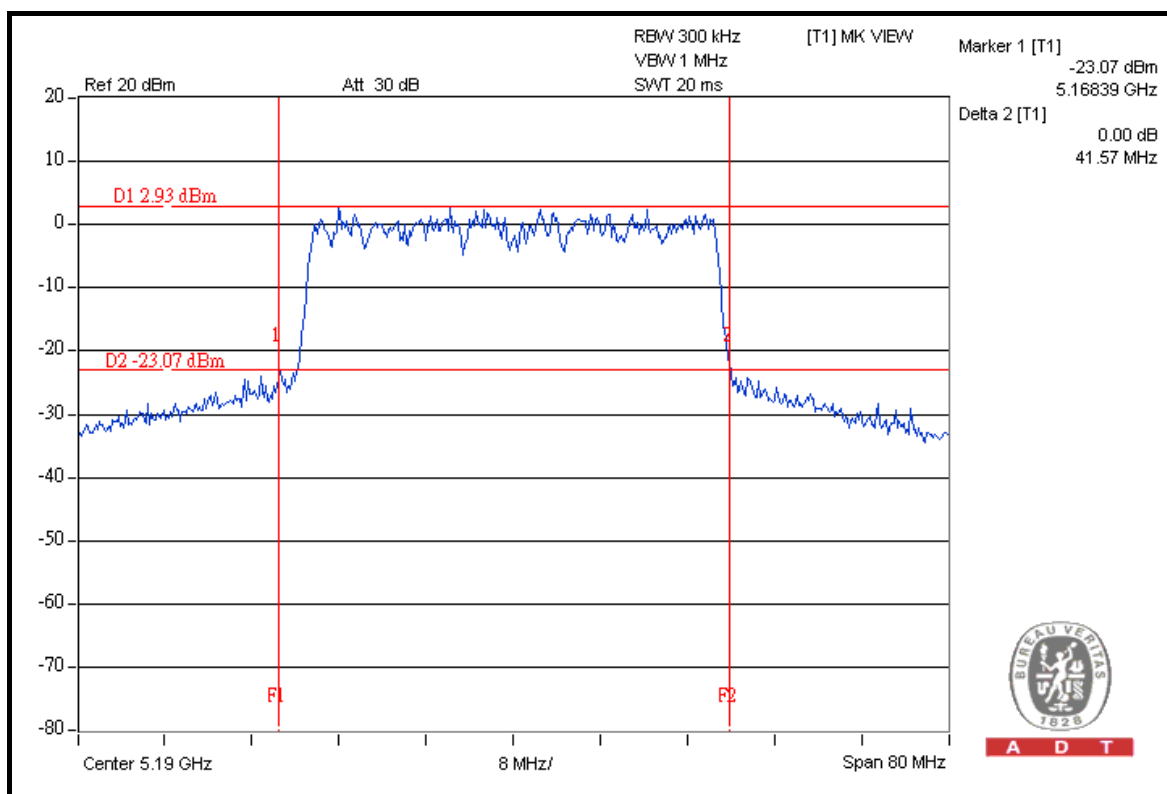

A D T

4.4 PEAK POWER EXCURSION MEASUREMENT

4.4.1 LIMITS OF PEAK POWER EXCURSION MEASUREMENT

FREQUENCY BAND	LIMIT
5.150 ~ 5.250GHz	13dB
5.250 ~ 5.350GHz	13dB
5.470 ~ 5.725GHz	13dB

4.4.2 TEST INSTRUMENTS

DESCRIPTION & MANUFACTURER	MODEL NO.	SERIAL NO.	DATE OF CALIBRATION	DUE DATE OF CALIBRATION
SPECTRUM ANALYZER R&S	FSP40	100040	Jul. 07, 2009	Jul. 06, 2010

NOTE: The calibration interval of the above test instruments is 12 months and the calibrations are traceable to NML/ROC and NIST/USA.

4.4.3 TEST PROCEDURE

- a. The transmitter output was connected to the spectrum analyzer.
- b. Set the spectrum bandwidth span to view the entire spectrum.
- c. Using peak detector and Max-hold function for Trace 1 (RB = 1MHz, VB = 3MHz) and 2 (RB = 1MHz, VB = 300 kHz).
- d. The differences between Trace1 and Trace 2 in any 1MHz band at f1 to f2 range were recorded and showed to another trace.

4.4.4 DEVIATION FROM TEST STANDARD

No deviation.

4.4.5 TEST SETUP



4.4.6 EUT OPERATING CONDITIONS

The software provided by client to enable the EUT under transmission condition continuously at specific channel frequencies individually.



4.4.7 TEST RESULTS

TX (40MHz)

CHANNEL	CHANNEL FREQUENCY (MHz)	PEAK POWER EXCURSION (dB)				PEAK TO AVERAGE EXCURSION LIMIT (dB)	PASS/ FAIL
		CHAIN 0	CHAIN 1	CHAIN 2	CHAIN 3		
1	5190	9.44	8.70	9.84	9.40	13	PASS
2	5230	9.07	9.60	9.28	8.68	13	PASS
3	5270	9.03	8.99	9.95	9.01	13	PASS
4	5310	9.04	9.04	9.96	8.95	13	PASS
5	5510	8.68	9.27	8.70	8.59	13	PASS
6	5550	8.78	8.61	9.10	8.96	13	PASS



A D T

CH 4

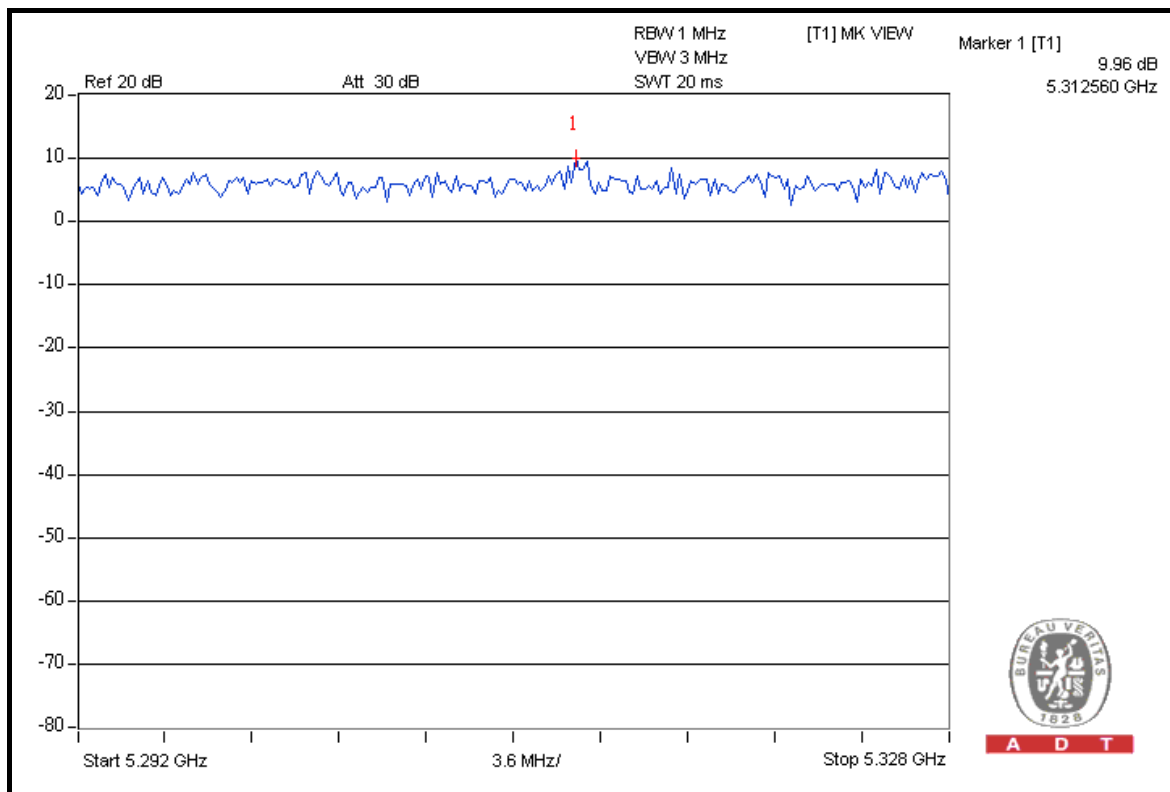
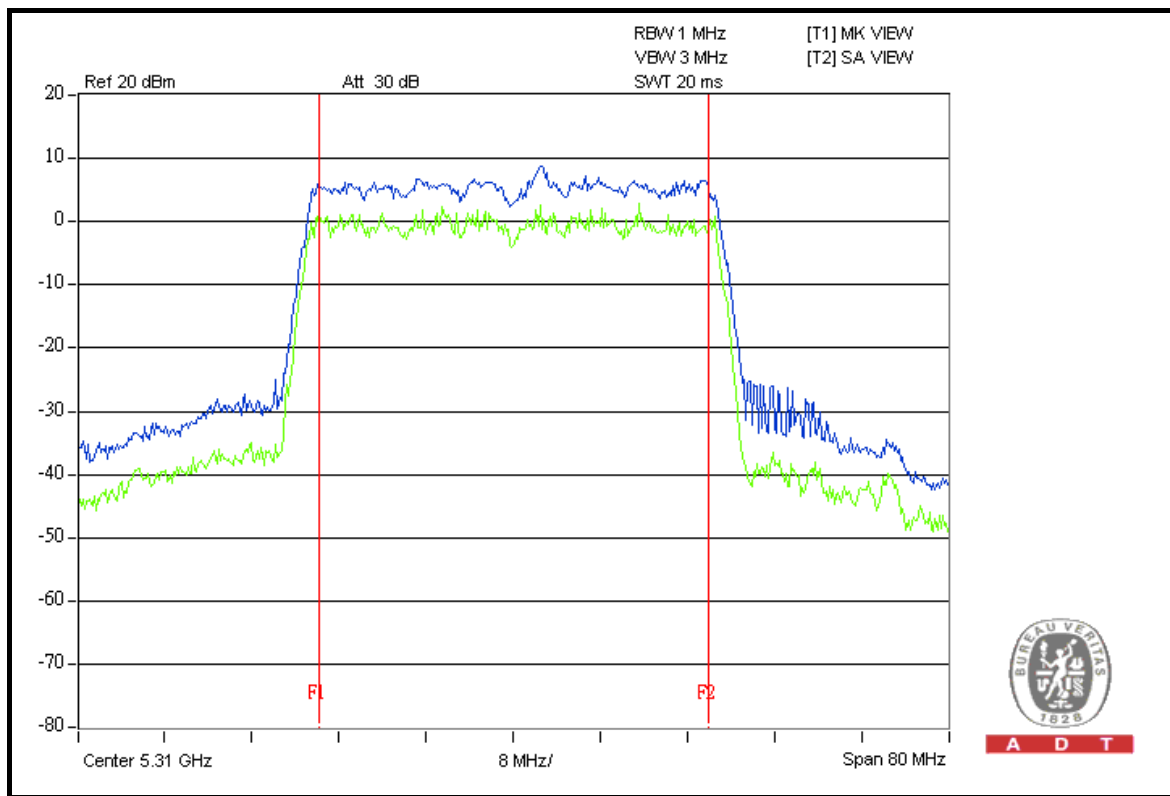

4.5 PEAK POWER SPECTRAL DENSITY MEASUREMENT

4.5.1 LIMITS OF PEAK POWER SPECTRAL DENSITY MEASUREMENT

FREQUENCY BAND	LIMIT
5.150 ~ 5.250GHz	4dBm
5.250 ~ 5.350GHz	11dBm
5.470 ~ 5.725GHz	11dBm

4.5.2 TEST INSTRUMENTS

DESCRIPTION & MANUFACTURER	MODEL NO.	SERIAL NO.	DATE OF CALIBRATION	DUE DATE OF CALIBRATION
SPECTRUM ANALYZER R&S	FSP40	100040	Jul. 07, 2009	Jul. 06, 2010

NOTE: The calibration interval of the above test instruments is 12 months and the calibrations are traceable to NML/ROC and NIST/USA.

4.5.3 TEST PROCEDURES

- a. The transmitter output was connected to the spectrum analyzer.
- b. Set RBW = 1MHz, VBW = 3MHz, detector type = Sample. The PPSD is the highest level found across the emission in any 1MHz band.

4.5.4 DEVIATION FROM TEST STANDARD

No deviation.

4.5.5 TEST SETUP



4.5.6 EUT OPERATING CONDITIONS

Same as 5.3.6.



A D T

4.5.7 TEST RESULTS

TX (40MHz)

CHAN.	CHAN. FREQ. (MHz)	RF POWER LEVEL IN 3kHz BW (dBm)				TOTAL POWER DENSITY (dBm)	MAX. LIMIT (dBm)	PASS / FAIL
		CHAIN 0	CHAIN 1	CHAIN 2	CHAIN 3			
1	5190	-6.3	-6.2	-6.3	-6.0	-0.2	4	PASS
2	5230	-6.0	-6.0	-6.2	-6.3	-0.1	4	PASS
3	5270	-6.9	-7.2	-7.1	-6.8	-1.0	11	PASS
4	5310	-6.5	-6.7	-7.0	-6.3	-0.6	11	PASS
5	5510	-6.9	-6.9	-6.9	-6.9	-0.9	11	PASS
6	5550	-6.4	-6.9	-6.8	-7.0	-0.7	11	PASS

CH 2

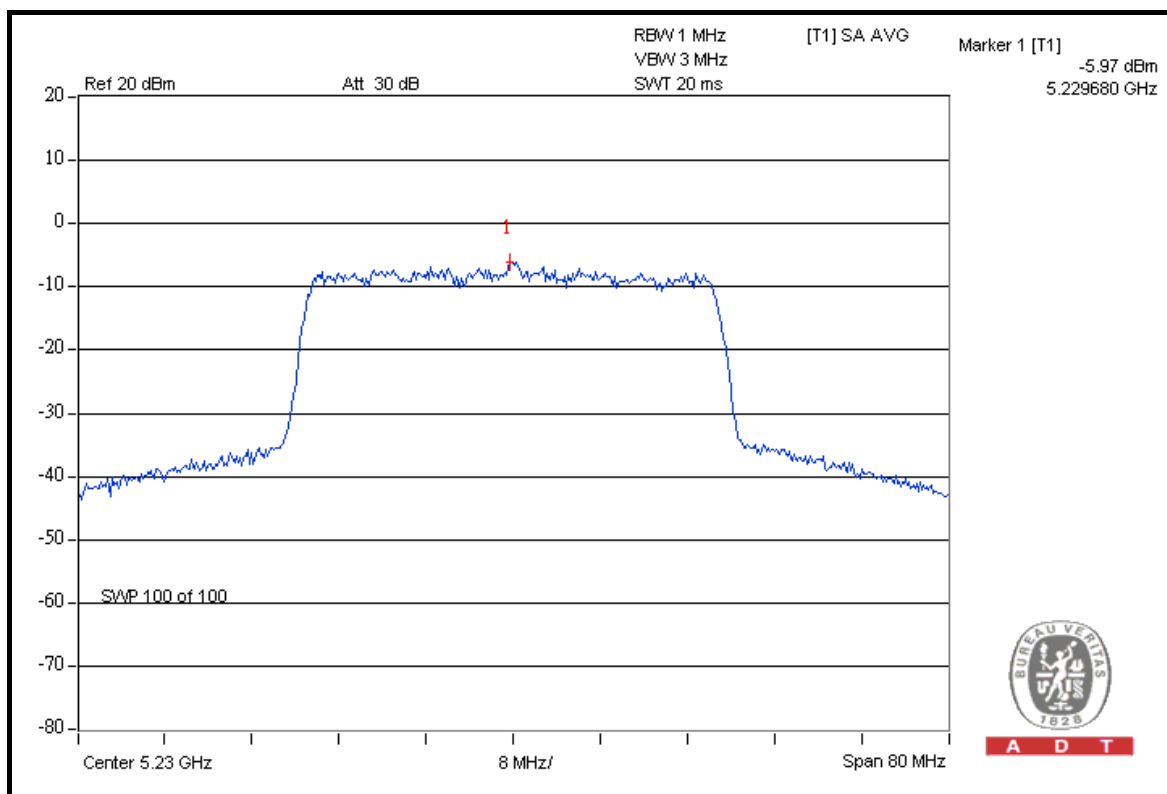

A D T

4.6 FREQUENCY STABILITY

4.6.1 LIMITS OF FREQUENCY STABILITY MEASUREMENT

The frequency tolerance of the carrier signal shall be maintained within the band of operation frequency over a temperature variation of –30 degrees to 50 degrees C at normal supply voltage, and for a variation in the primary supply voltage from 85% to 115% of the rated supply voltage at a temperature of 20 degrees C.

4.6.2 TEST INSTRUMENTS

DESCRIPTION & MANUFACTURER	MODEL NO.	SERIAL NO.	DATE OF CALIBRATION	CALIBRATED UNTIL
SPECTRUM ANALYZER R&S	FSP40	100040	Jul. 07, 2009	Jul. 06, 2010
WIT STANDARD TEMPERATURE AND HUMIDITY CHAMBER	TH-4S-C	W981030	Jun. 24, 2009	Jun. 23, 2010

NOTE: The calibration interval of the above test instruments is 12 months and the calibrations are traceable to NML/ROC and NIST/USA.

4.6.3 TEST PROCEDURE

- a. The EUT was placed inside the environmental test chamber and powered by nominal DC voltage.
- b. Turn the EUT on and couple its output to a spectrum analyzer.
- c. Turn the EUT off and set the chamber to the highest temperature specified.
- d. Allow sufficient time (approximately 30 min) for the temperature of the chamber to stabilize, turn the EUT on and measure the operating frequency after 2, 5, and 10 minutes.
- e. Repeat step 2 and 3 with the temperature chamber set to the lowest temperature.
- f. The test chamber was allowed to stabilize at +20 degree C for a minimum of 30 minutes. The supply voltage was then adjusted on the EUT from 85% to 115% and the frequency record.

4.6.4 DEVIATION FROM TEST STANDARD

No deviation.

4.6.5 TEST SETUP

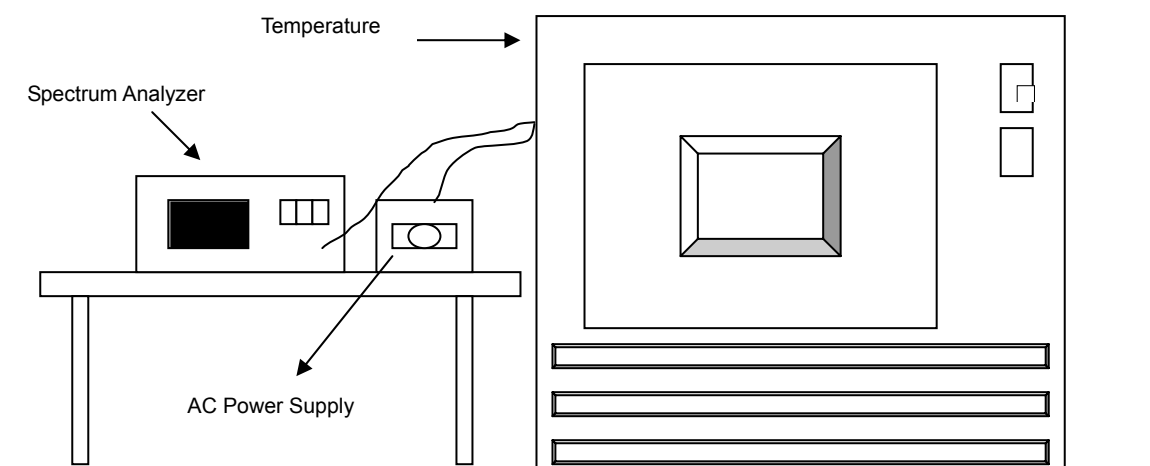

4.6.6 EUT OPERATING CONDITION

Same as Item 4.1.7.



A D T

4.6.7 TEST RESULTS

FREQUENCY STABILITY VERSUS TEMP.									
OPERATING FREQUENCY: 5310MHz									
TEMP. (°C)	POWER SUPPLY (Vdc)	0 MINUTE		2 MINUTE		5 MINUTE		10 MINUTE	
		Measured Frequency	Frequency Drift	Measured Frequency	Frequency Drift	Measured Frequency	Frequency Drift	Measured Frequency	Frequency Drift
		(MHz)	ppm	(MHz)	ppm	(MHz)	ppm	(MHz)	ppm
55	5.00	5309.930880	-13.017	5309.931083	-12.979	5309.931005	-12.993	5309.931073	-12.981
50	5.00	5309.930850	-13.023	5309.930717	-13.048	5309.931277	-12.942	5309.931226	-12.952
40	5.00	5309.930799	-13.032	5309.930861	-13.021	5309.931052	-12.985	5309.930780	-13.036
30	5.00	5309.957400	-8.023	5309.957421	-8.019	5309.957663	-7.973	5309.957576	-7.989
20	5.00	5309.955900	-8.305	5309.956212	-8.246	5309.955803	-8.323	5309.956320	-8.226
10	5.00	5309.954522	-8.565	5309.954544	-8.560	5309.954674	-8.536	5309.954757	-8.520
0	5.00	5309.948520	-9.695	5309.948288	-9.739	5309.948862	-9.631	5309.948469	-9.705
-10	5.00	5309.947890	-9.814	5309.948171	-9.761	5309.948181	-9.759	5309.947866	-9.818
-20	5.00	5309.941840	-10.953	5309.941937	-10.935	5309.942009	-10.921	5309.941593	-10.999

FREQUENCY STABILITY VERSUS VOLTAGE									
OPERATING FREQUENCY: 5310MHz									
TEMP. (°C)	POWER SUPPLY (Vac)	0 MINUTE		2 MINUTE		5 MINUTE		10 MINUTE	
		Measured Frequency	Frequency Drift	Measured Frequency	Frequency Drift	Measured Frequency	Frequency Drift	Measured Frequency	Frequency Drift
		(MHz)	ppm	(MHz)	ppm	(MHz)	ppm	(MHz)	ppm
20	4.25	5309.930880	-13.017	5309.931282	-12.941	5309.930844	-13.024	5309.930740	-13.043
	5.00	5309.957400	-8.023	5309.957421	-8.019	5309.957663	-7.973	5309.957576	-7.989
	5.75	5309.931720	-12.859	5309.932059	-12.795	5309.932132	-12.781	5309.931957	-12.814

4.7 BAND EDGES MEASUREMENT

4.7.1 TEST INSTRUMENTS

DESCRIPTION & MANUFACTURER	MODEL NO.	SERIAL NO.	DATE OF CALIBRATION	DUE DATE OF CALIBRATION
Test Receiver ROHDE & SCHWARZ	ESI7	838496/016	Dec. 29, 2009	Dec. 28, 2010
Spectrum Analyzer ROHDE & SCHWARZ	FSP40	100076	May 26, 2009	May 25, 2010
BILOG Antenna SCHWARZBECK	VULB9168	9168-155	Apr. 29, 2009	Apr. 28, 2010
HORN Antenna SCHWARZBECK	BBHA 9120 D	9120D-405	Jan. 12, 2009	Jan. 11, 2010
HORN Antenna SCHWARZBECK	BBHA 9170	BBHA9170242	Jan. 06, 2009	Jan. 05, 2010
Preamplifier Agilent	8449B	3008A01961	Nov. 04, 2009	Nov. 03, 2010
Preamplifier Agilent	8447D	2944A10738	Nov. 04, 2009	Nov. 03, 2010
RF signal cable HUBER+SUHNNER	SUCOFLEX 104	274041/4	Aug. 28, 2009	Aug. 27, 2010
RF signal cable HUBER+SUHNNER	SUCOFLEX 104	283397/4	Aug. 28, 2009	Aug. 27, 2010
Software ADT.	ADT_Radiated_ V7.6.15.9.2	NA	NA	NA
Antenna Tower inn-co GmbH	MA 4000	010303	NA	NA
Antenna Tower Controller inn-co GmbH	CO2000	019303	NA	NA
Turn Table ADT.	TT100.	TT93021704	NA	NA
Turn Table Controller ADT.	SC100.	SC93021704	NA	NA
26GHz ~ 40GHz Amplifier	EM26400	07026401	Aug. 27, 2009	Aug. 26, 2010

NOTE: The calibration interval of the above test instruments is 12 months and the calibrations are traceable to NML/ROC and NIST/USA.

4.7.2 TEST PROCEDURE

- a. The EUT was placed on the top of a rotating table 0.8 meters above the ground at a 3 meter semi-anechoic chamber. The table was rotated 360 degrees to determine the position of the highest radiation.
- b. The EUT was set 3 meters away from the interference-receiving antenna, which was mounted on the top of a variable-height antenna tower.
- c. The antenna is a broadband antenna, and its height is varied from one meter to four meters above the ground to determine the maximum value of the field strength. Both horizontal and vertical polarizations of the antenna are set to make the measurement.
- d. For each suspected emission, the EUT was arranged to its worst case and then the antenna was tuned to heights from 1 meter to 4 meters and the rotatable table was turned from 0 degrees to 360 degrees to find the maximum reading.
- e. Set both RBW and VBW of spectrum analyzer to 1MHz and 3MHz with suitable frequency span including 100MHz bandwidth from band edge. The band edges was measured and recorded.

NOTE: The resolution bandwidth of test receiver/spectrum analyzer is 1MHz and the video bandwidth is 10Hz for Average detection (AV) at frequency above 1GHz

4.7.3 EUT OPERATING CONDITION

The software provided by client to enable the EUT under transmission condition continuously at specific channel frequencies individually.

4.7.4 TEST RESULTS

For signals in the restricted bands above and below the 5.19 to 5.31GHz and 5.51 to 5.55GHz allocated band a measurement was made of the amplitude of the spurious emissions with respect to the intentional signals. The relative amplitude, in dBc, was applied to the average and peak field strength of the intentional signal made on the OATS to calculate the field strength of the unintentional signals.

The spectrum plots (Peak RBW = 1MHz, VBW = 3MHz) are attached on the following pages.

FOR 5190-5310MHz BAND: TX (40MHz)

RESTRICT BAND (4500 ~ 5150 MHz)

FREQUENCY (MHz)	FUNDAMENTAL EMISSION (dBuV/m)	DELTA (dB)	MAXIMUM FIELD STRENGTH IN RESTRICT BAND (dBuV/m)	LIMIT (dBuV/m)
5190.00 (PK)	109.4	39.37	70.03	74.00
5190.00 (AV)	94.0	41.42	52.58	54.00

RESTRICT BAND (5350 ~ 5460 MHz)

FREQUENCY (MHz)	FUNDAMENTAL EMISSION (dBuV/m)	DELTA (dB)	MAXIMUM FIELD STRENGTH IN RESTRICT BAND (dBuV/m)	LIMIT (dBuV/m)
5310.00 (PK)	107.0	39.95	67.05	74.00
5310.00 (AV)	93.4	43.28	50.12	54.00

NOTE:

- Delta = Amplitude between the peak of the fundamental and the peak of the band edge emission. Please check following 3 pages.
- Maximum field strength in restrict band = Fundamental emission – Delta.



A D T

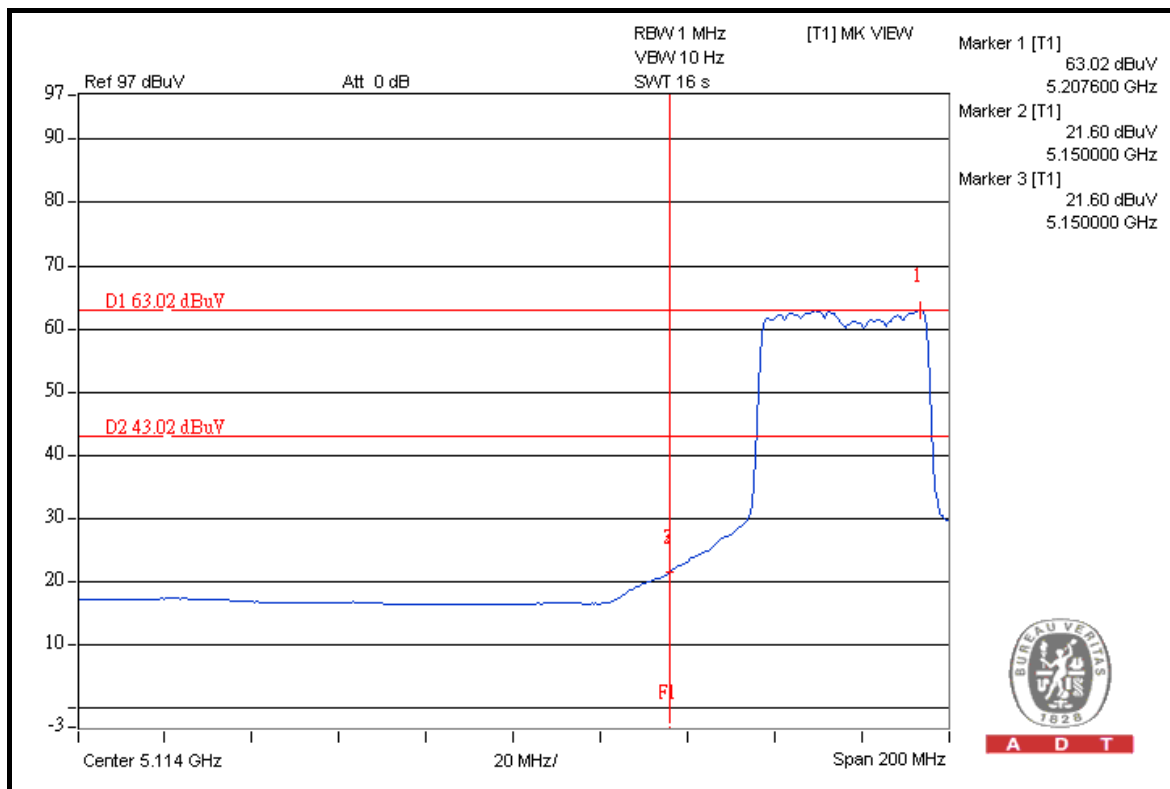
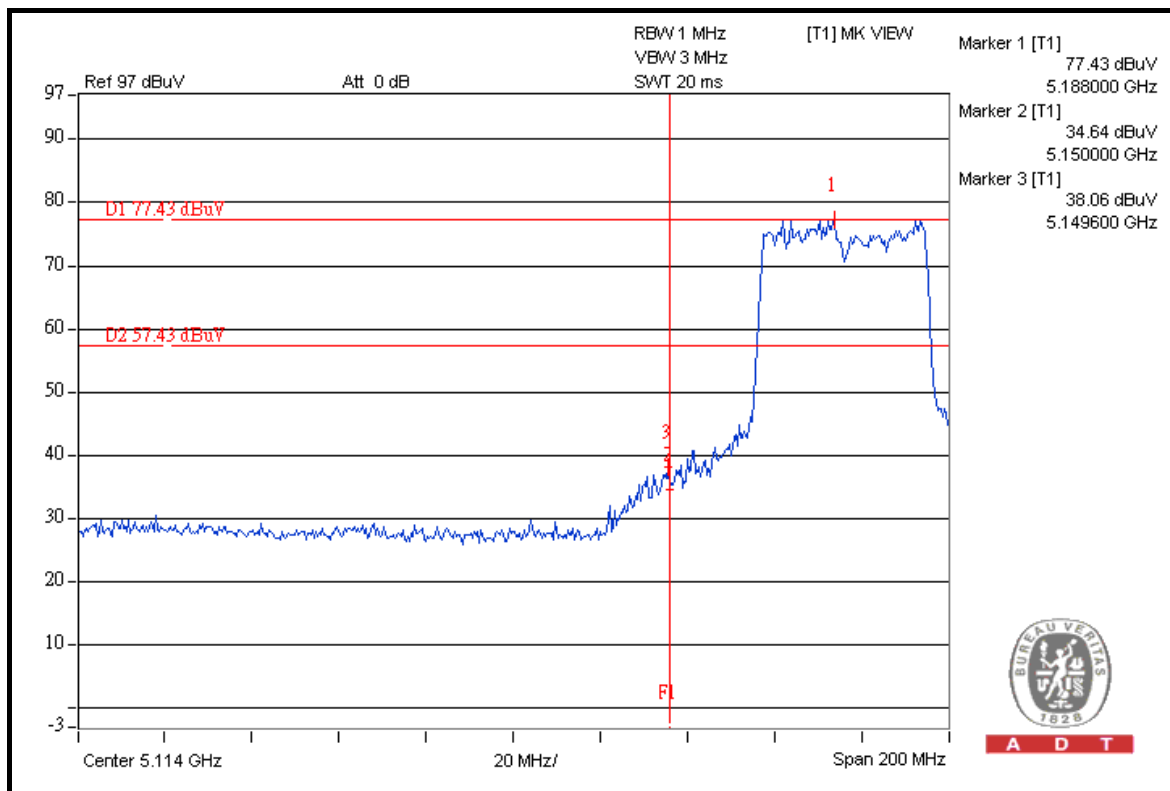



A D T

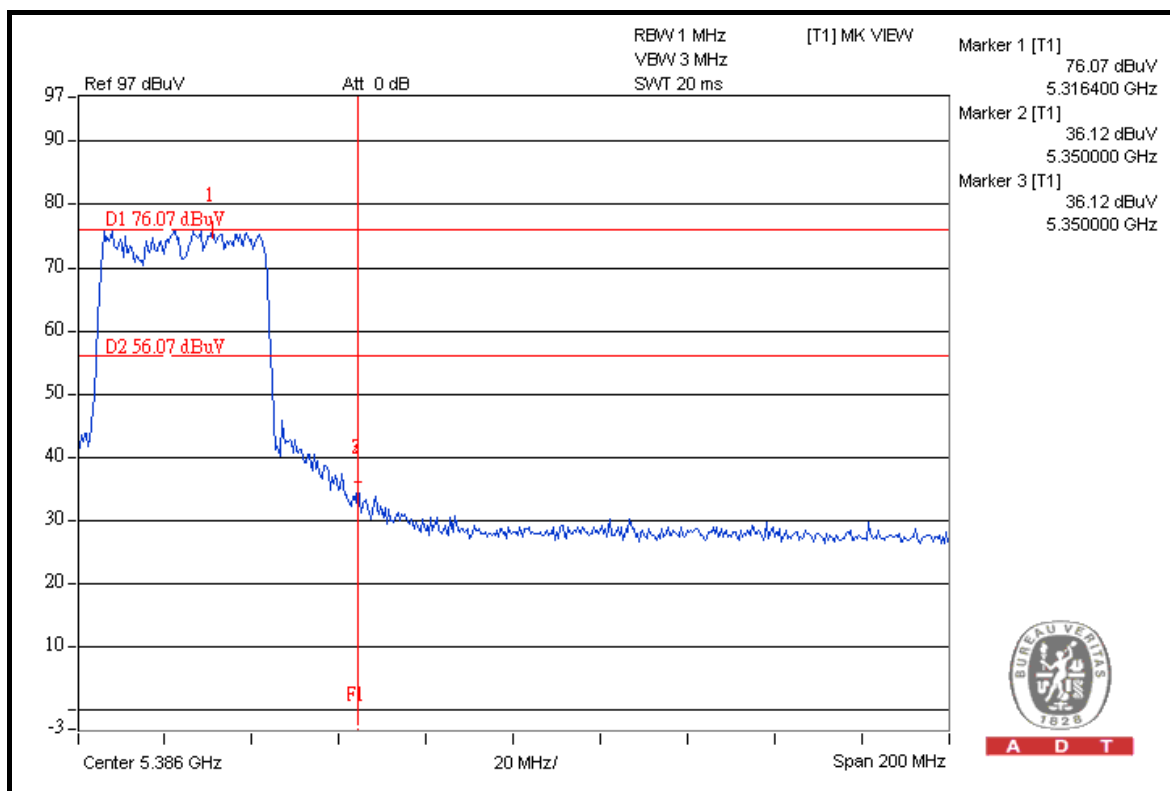
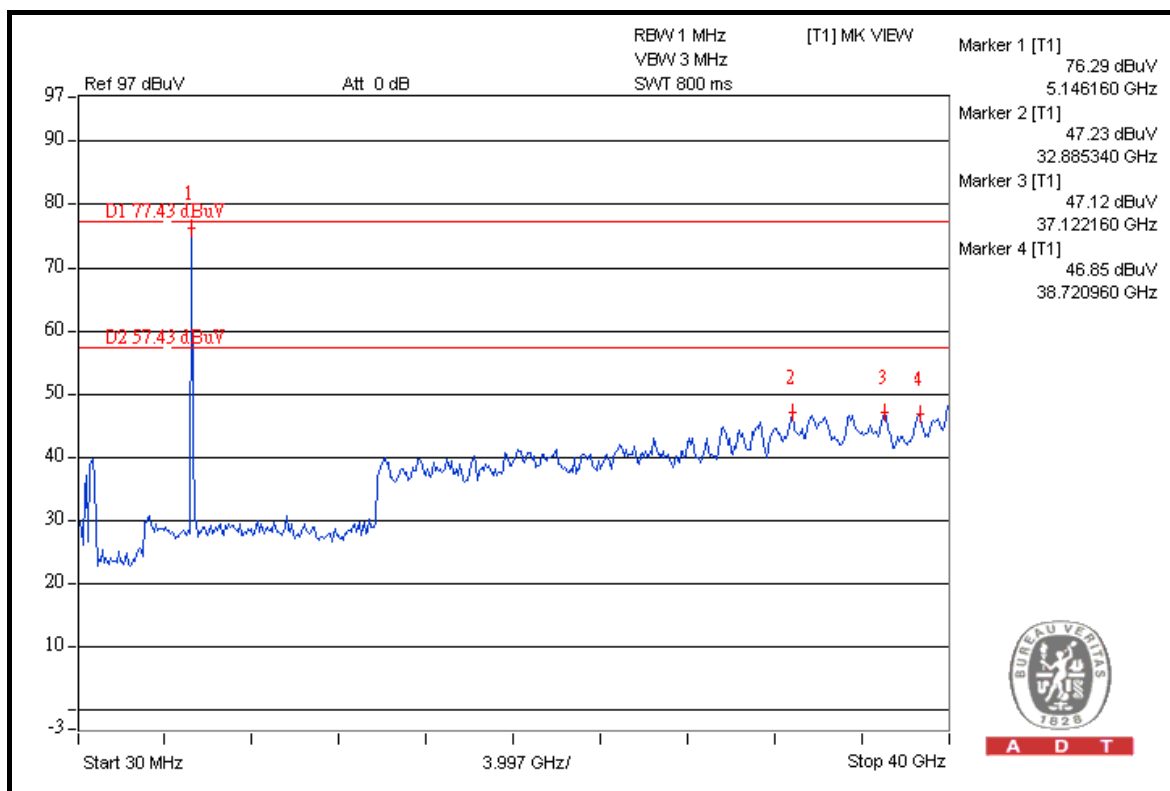



A D T

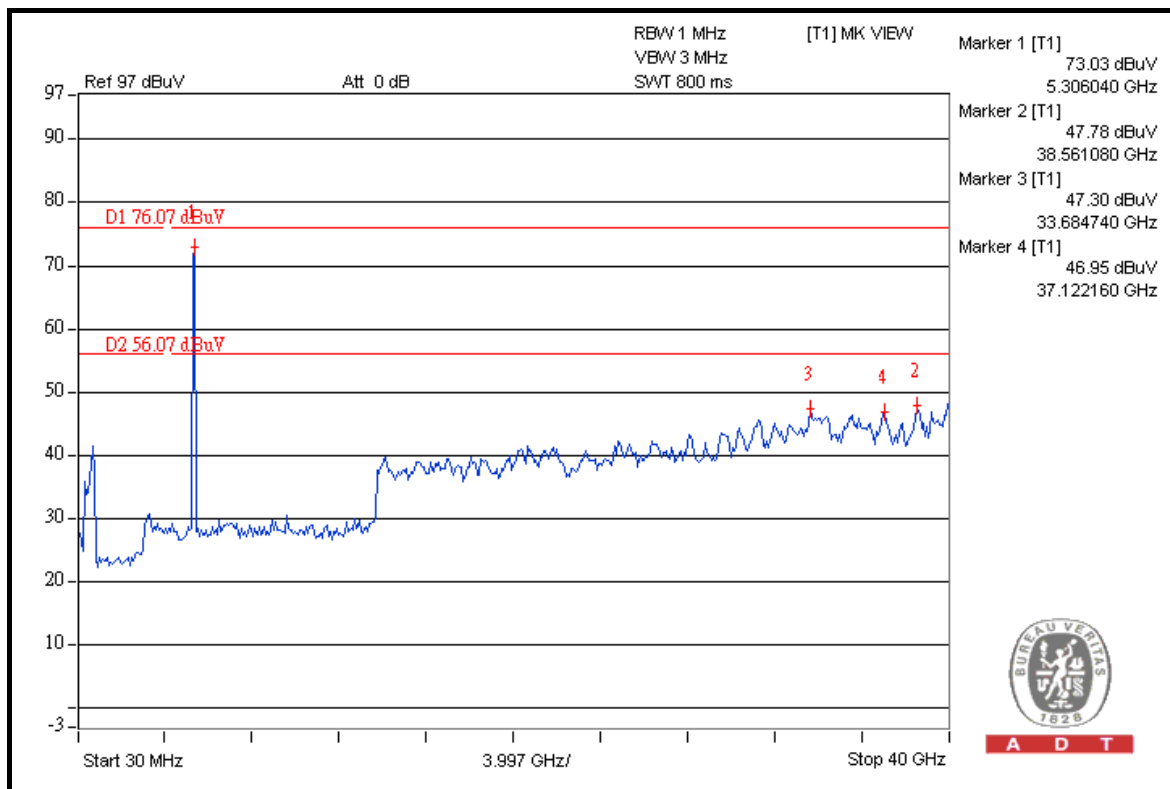
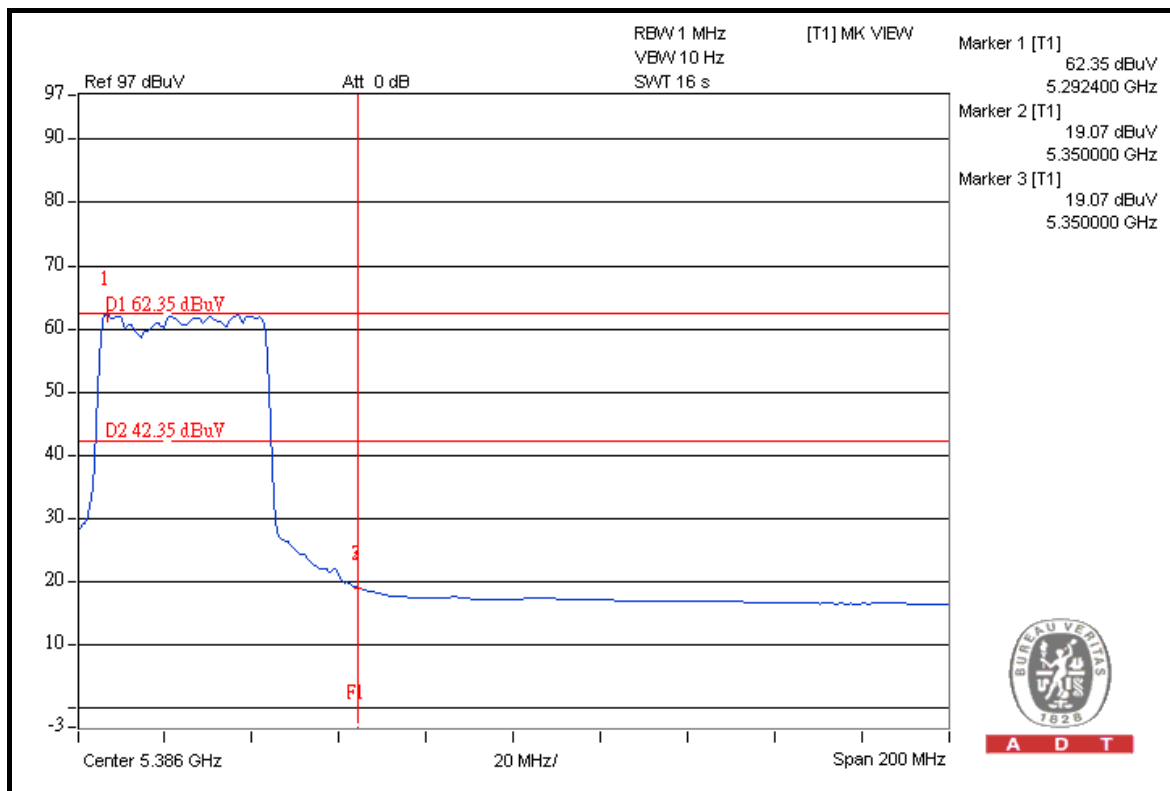

FOR 5510-5550MHz BAND: TX (40MHz)

5510MHz

RESTRICT BAND (5350 ~ 5460 MHz)

FREQUENCY (MHz)	FUNDAMENTAL EMISSION (dBuV/m)	DELTA (dB)	MAXIMUM FIELD STRENGTH IN RESTRICT BAND (dBuV/m)	LIMIT (dBuV/m)
5510.00 (PK)	106.2	44.70	61.50	74.00
5510.00 (AV)	93.0	42.95	50.05	54.00

FREQUENCY BAND (5460 ~ 5470 MHz)

FREQUENCY (MHz)	FUNDAMENTAL EMISSION (dBuV/m)	DELTA (dB)	MAXIMUM FIELD STRENGTH (dBuV/m)	LIMIT (dBuV/m)
5510.00 (PK)	106.2	45.33	60.87	68.30

5550MHz

ABOVE 5725 MHz

FREQUENCY (MHz)	FUNDAMENTAL EMISSION (dBuV/m)	DELTA (dB)	MAXIMUM FIELD STRENGTH (dBuV/m)	LIMIT (dBuV/m)
5550.00 (PK)	105.3	43.81	61.49	68.30

NOTE:

- Delta = Amplitude between the peak of the fundamental and the peak of the band edge emission. Please check following 3 pages.
- Maximum field strength in restrict band = Fundamental emission – Delta.



A D T

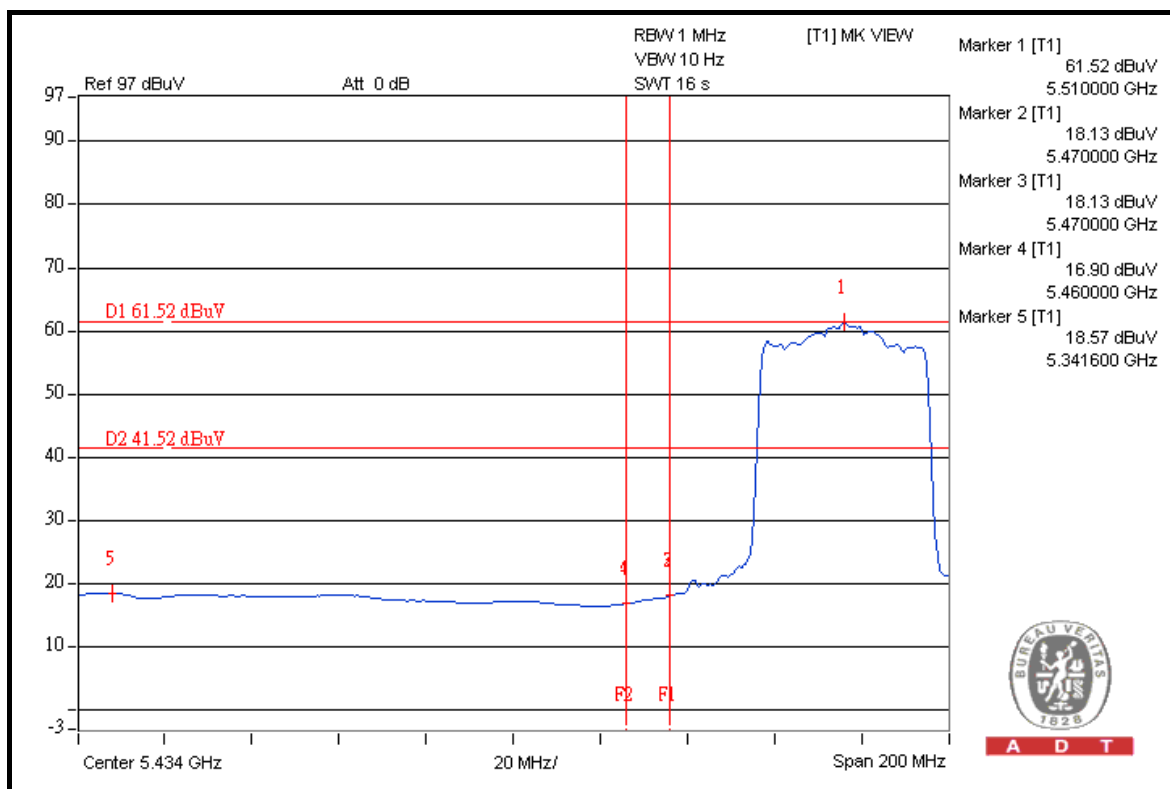
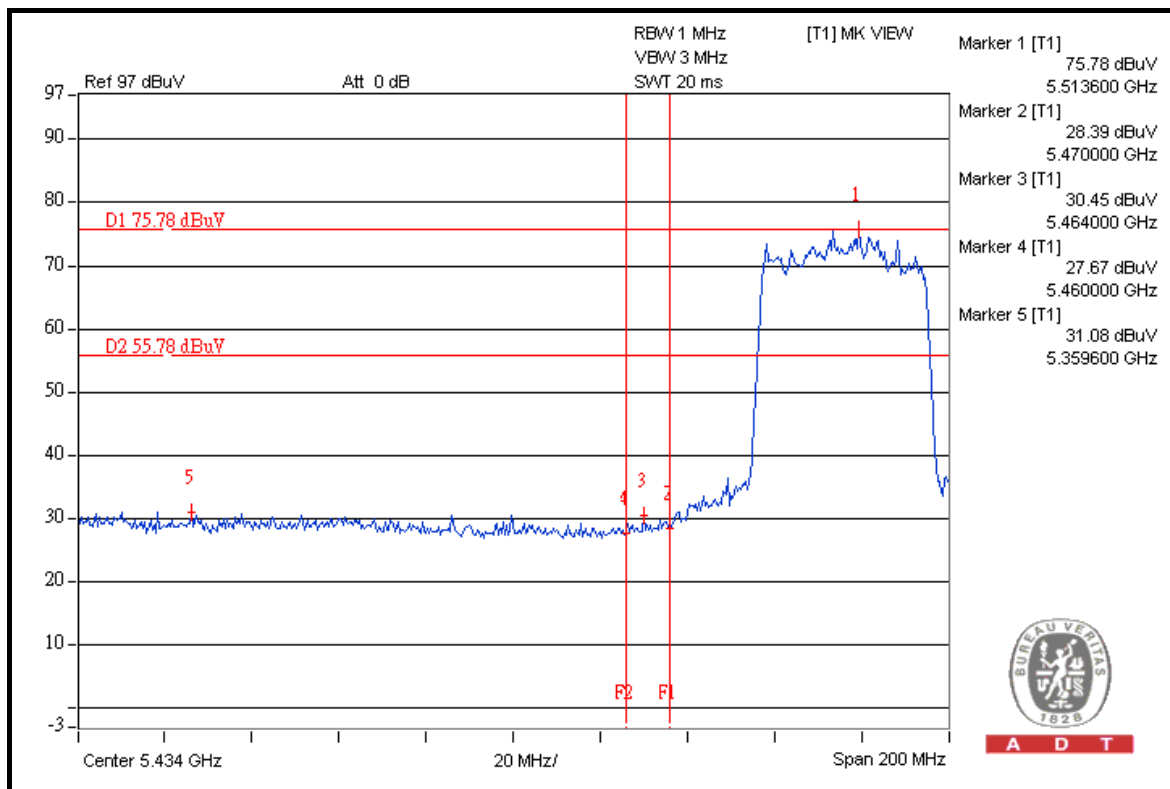



A D T

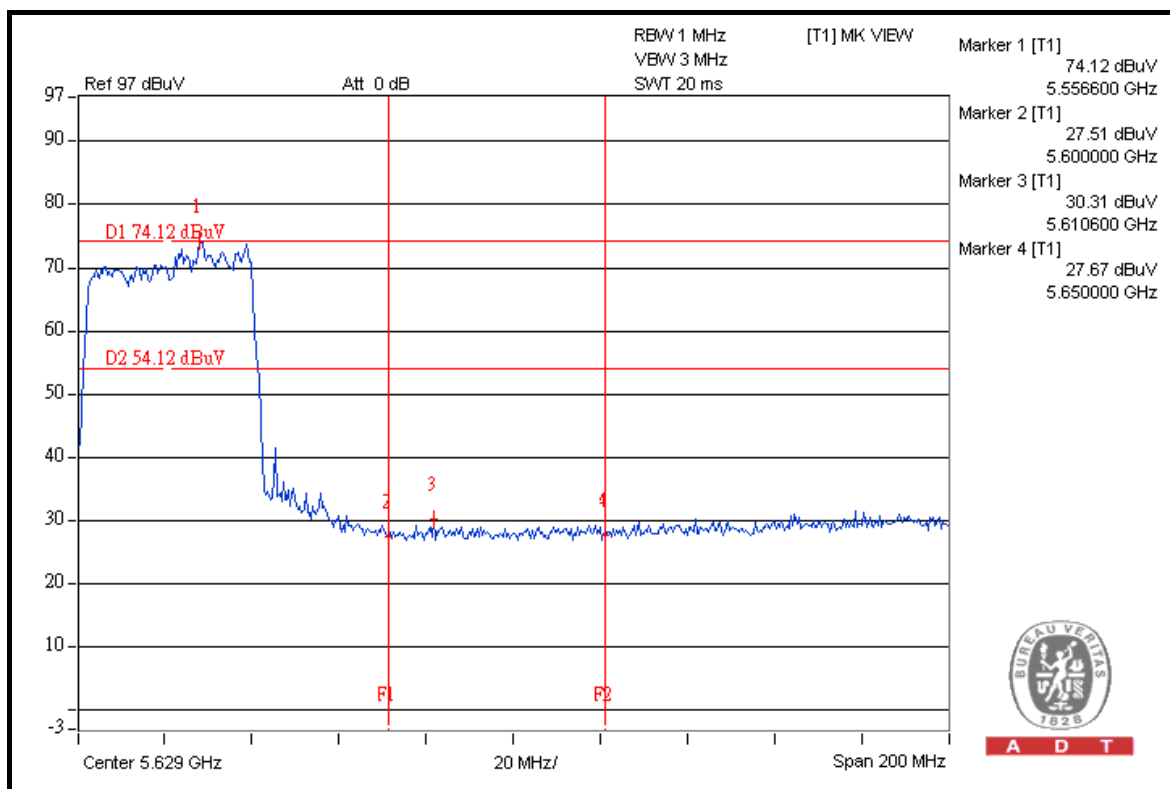
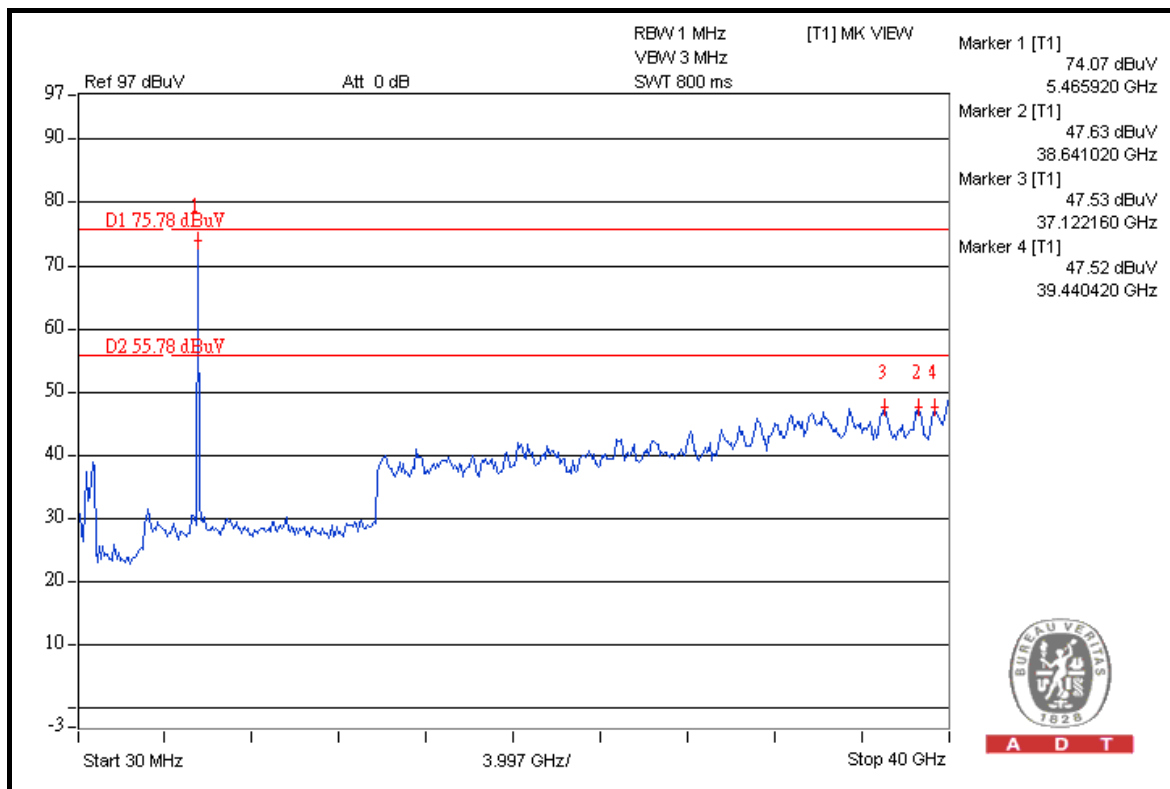



A D T

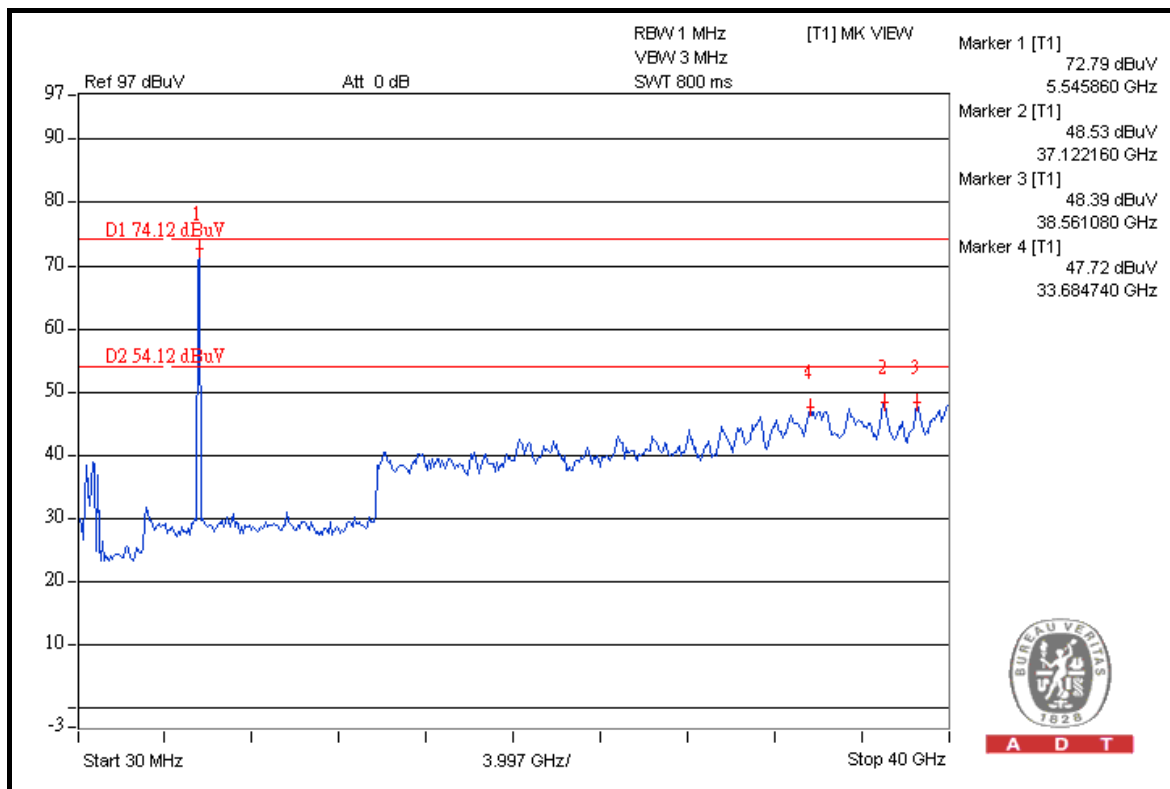
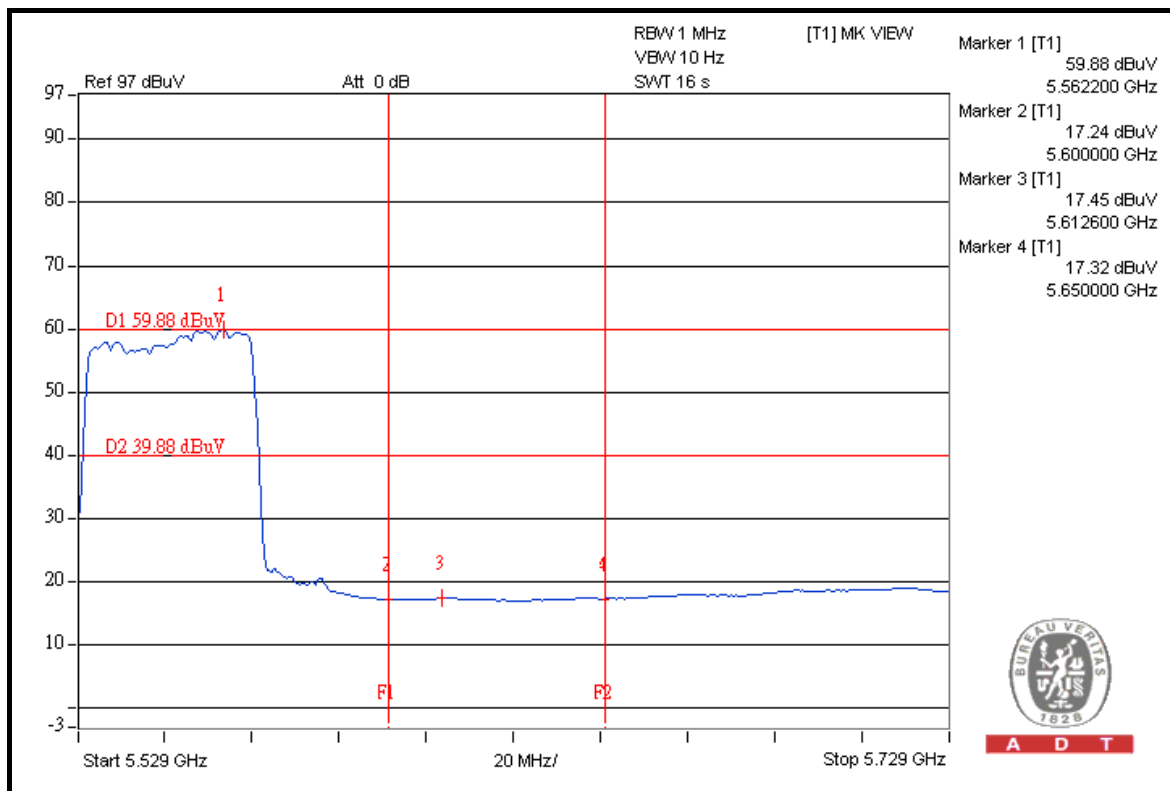

5. PHOTOGRAPHS OF THE TEST CONFIGURATION

Please refer to the attached file (Test Setup Photo).



6. INFORMATION ON THE TESTING LABORATORIES

We, Bureau Veritas Consumer Products Services (H.K.) Ltd., Taoyuan Branch, were founded in 1988 to provide our best service in EMC, Radio, Telecom and Safety consultation. Our laboratories are accredited and approved according to ISO/IEC 17025.

Copies of accreditation certificates of our laboratories obtained from approval agencies can be downloaded from our web site:

www.adt.com.tw/index.5/phtml. If you have any comments, please feel free to contact us at the following:

Linko EMC/RF Lab:

Tel: 886-2-26052180

Fax: 886-2-26051924

Hsin Chu EMC/RF Lab:

Tel: 886-3-5935343

Fax: 886-3-5935342

Hwa Ya EMC/RF/Safety Telecom Lab:

Tel: 886-3-3183232

Fax: 886-3-3185050

Web Site: www.adt.com.tw

The address and road map of all our labs can be found in our web site also.

7. APPENDIX A - MODIFICATIONS RECORDERS FOR ENGINEERING CHANGES TO THE EUT BY THE LAB

No any modifications are made to the EUT by the lab during the test.

---END---