

# User Manual

Product name: Wireless Audio Module Product

Model: WL1BKR23 / WL1BKT23

Document No:

Version: V

Availability date: [2023-06-05](#)

Edit	Review	Approve
ChaoMa		Xiao_Chen

# 1. General specifications

WL1BKR23 and WL1BKT23 is a small size and low power wireless audio transmitter module, which is designed based on Beken CC258 MCU and Beken BK5813 RF Chip.

- Forced the [5.2 / 5.8 GHz](#) GFSK modulation [[CE/UKCA only used 5.8GHz](#)]
- Size: 35MMx35MMx5. 03mm
- PCB onboard antenna
- I2S digital audio interface
- Built-in MCU memory 256K, BUILT-IN MCU flash memory 192K
- I2C controls external devices
- I/O configuration
- Primary and secondary audio delay time <20ms
- Applications: Wireless speakers, wireless subwoofers, home theater Module style
- operating temperature -10° C ~ +60° C
- working voltage  $3.3V \pm 0.15V$

## 2. Module style

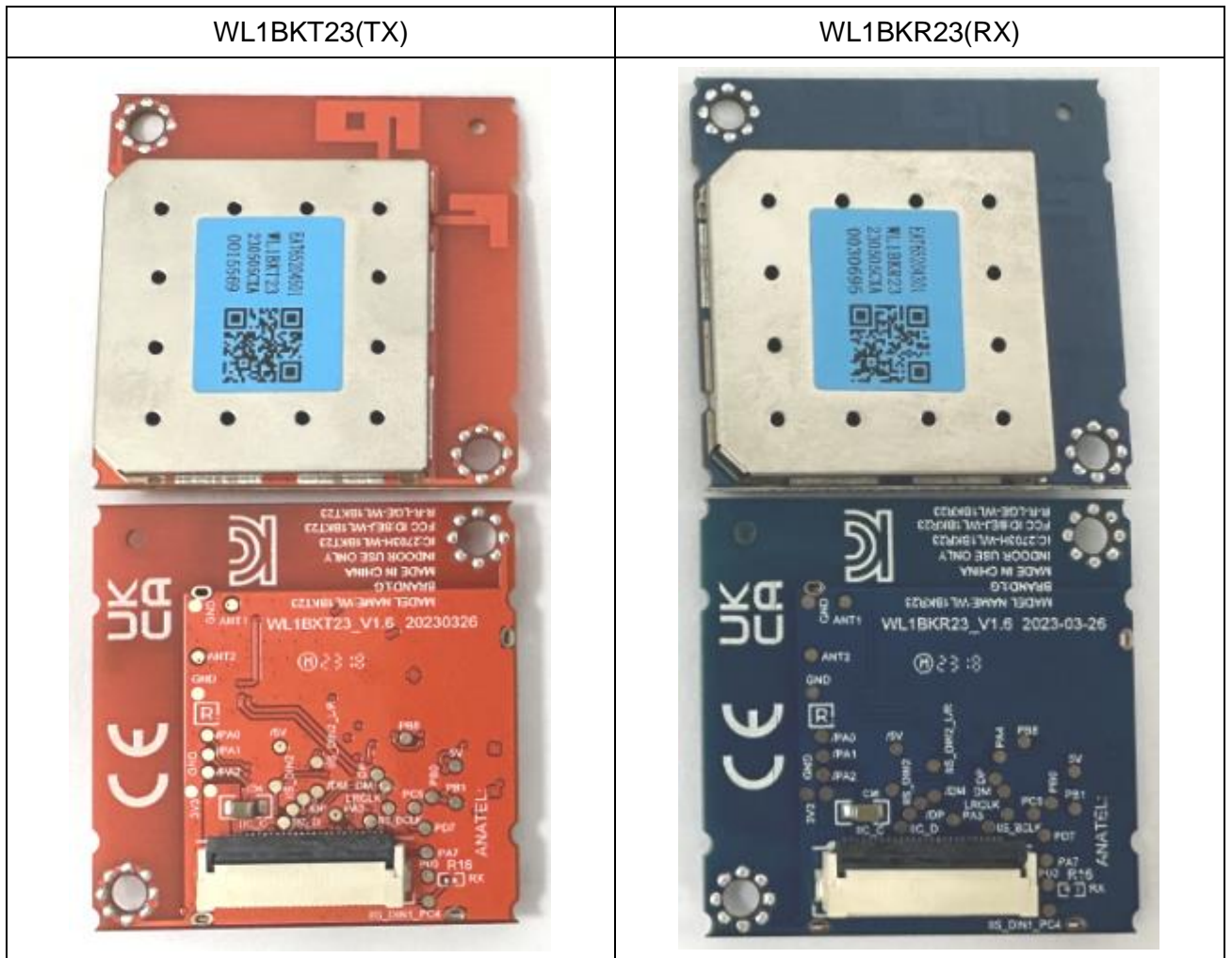

# 3. The application UI

## WL1BKT23 Operation description

- First: the module is powered on and started by 3.3V;
- Second: the host transmits the audio signal to the module through I2S;
- Third: THE MCU CC2538 on the module decodes the I2S audio signal, and then transmits the decoded audio signal to the BK5813 RF chip on the module through SPI;
- Fourth: the BK5813 RF chip on the module transmits the audio through wireless transmission;
- Fifth: there is I2C communication between the module and the host, both sides obtain the status and control through I2C;
- The product automatically stops the transmission if the information fails to be transferred or the operation fails.
- WL1BKT23 as the main device

## WL1BKR23 Operation description

- First: The module is powered on and started by 3.3V;
- Second: The BK5813 RF chip on the module receives the audio signal transmitted by the transmitting module through wireless transmission;
- Third: MCU CC2538 on the module obtains the audio received by BK5813 through SPI;
- Fourth: MCU CC2538 decodes the acquired audio signal and transmits the audio to the power amplifier on the subwoofer power amplifier board through I2S;
- Fifth: There is I2C communication between the module and the subwoofer power amplifier board, initializing the power amplifier on the subwoofer power amplifier board, and I0 port communication between the module and the subwoofer power amplifier board, controlling the power amplifier switch and LED state display.
- WL1BKR23 is a client device controlled by the WL1BKT23.

WL1BKT23 device is classified as a master device.

WL1BKR23 is classified as a Client device under the control of the WL1BKT23.

The product automatically stops the transmission if the information fails to be transferred or the operation fails.

ISED RSS-247 (6.4) required by the technology

When there is no information to transmit or an operation fails, the device automatically discontinues transmission. After the transmission is discontinued, the TX module enters the reconnection state until it is reconnected or the power supply is switched off passively. After the transmission is discontinued, the RX module enters the RE-connection state for one minute, if no connection, enters the standby mode after one minute.

FCC 15.407 (c) required by the technology

The device would automatically discontinue transmission if there is no information to transmit or if the operation fails. After the transmission is discontinued, the TX module enters the reconnection state until it is reconnected or the power supply is switched off passively. After the transmission is discontinued, the RX module enters the RE-connection state for one minute, if no connection, enters the standby mode after one minute.

WL1BKT23 (TX module):

The reconnection state is TX will transmit control signal to RX for pair each other.

The TX re-try to transmit control signal to RX on complete frame or burst intervals until they connect successfully or power supply be off passively.

WL1BKR23 (RX module):

The connection state is no transmit data by RX module. It's only permit to transmit the information that is repetitive codes to TX on complete frame or burst intervals.

The standby mode is enter sleep mode to save consumption power.

On this mode, the RX doesn't transmit any information or data to TX.

The module-[WL1BKT23] is installed in the speaker, and the signal of the sound is provided through the HDMI or Optical ports of the TV audio products; When the speaker receive the sound signal, it will transmit the sound signal to another speaker (which is installed with the module-[WL1BKR23]).

5150-5250MHz is limited to use indoor only

5150-5250MHz est limitée à une utilisation en intérieur uniquement.

## Block diagram

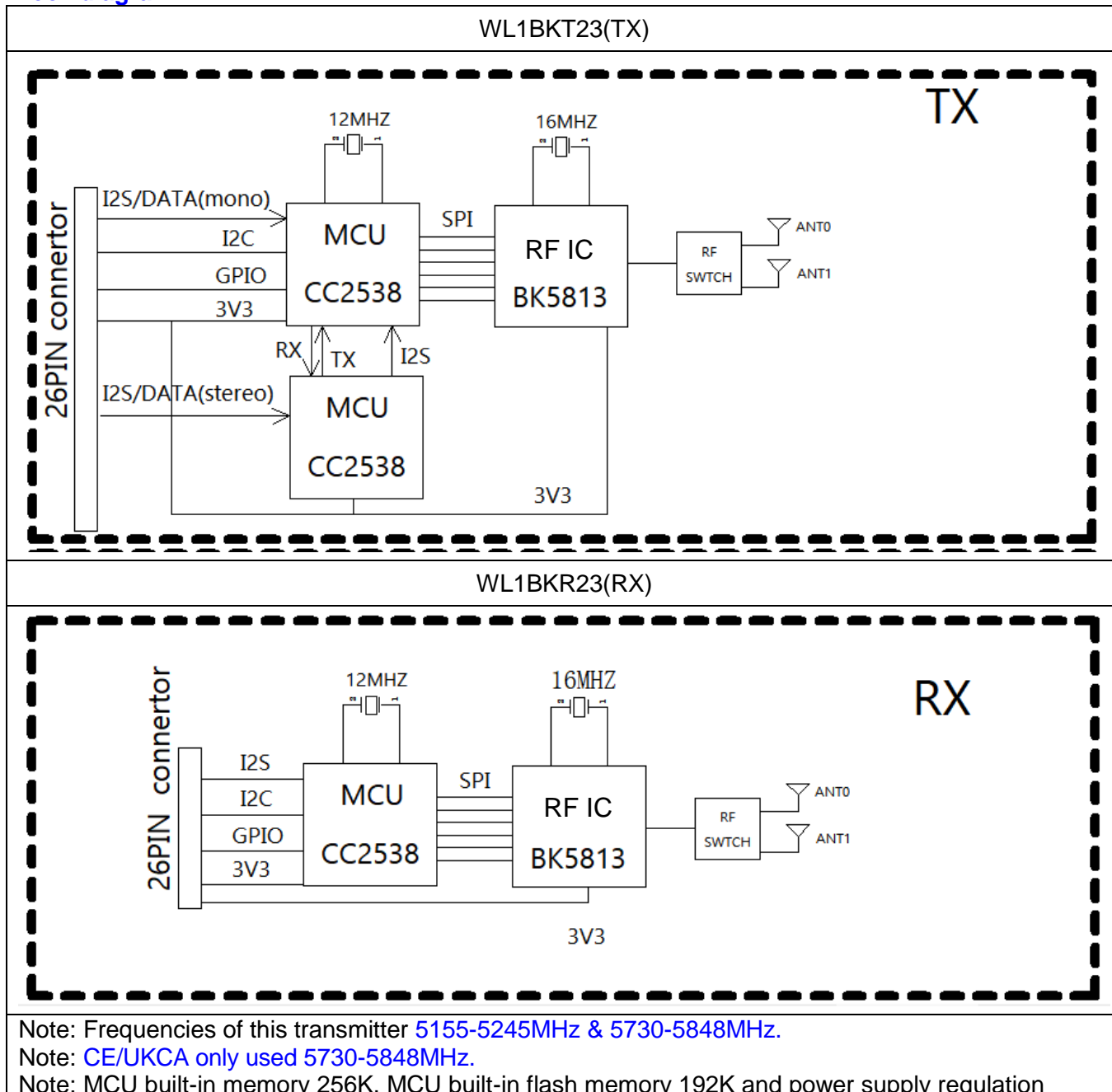

Note: Frequencies of this transmitter [5155-5245MHz](#) & [5730-5848MHz](#).

Note: [CE/UKCA](#) only used [5730-5848MHz](#).

Note: MCU built-in memory 256K, MCU built-in flash memory 192K and power supply regulation

# RF Technical Specification

<b>Product</b>	Wireless Audio Module		
<b>Brand</b>	LG		
<b>Modulation</b>	GFSK		
<b>Data Rate</b>	2 Mbps		
<b>Frequency Bands</b>	5155-5245MHz 5730-5848MHz [CE/UKCA only used 5730-5848MHz.]		
<b>RF Output Power WL1BKT23(TX)</b>	5155-5245MHz	6.0	dBm (AV) (FCC / IC Used)
	5730-5848MHz	8.5	dBm (AV) (FCC / IC Used)
		9.5	dBm (E.I.R.P) (EU UKCA Used)
<b>RF Output Power WL1BKR23(RX)</b>	5155-5245MHz	6.0	dBm (AV) (FCC / IC Used)
	5730-5848MHz	7.0	dBm (AV) (FCC / IC Used)
		9.5	dBm (E.I.R.P) (EU UKCA Used)

U-NII Band 1									
Channel Number	Frequency (MHz)	Channel Number	Frequency (MHz)	Channel Number	Frequency (MHz)	Channel Number	Frequency (MHz)	Channel Number	Frequency (MHz)
0	5155	20	5175	40	5195	60	5215	80	5235
1	5156	21	5176	41	5196	61	5216	81	5236
2	5157	22	5177	42	5197	62	5217	82	5237
3	5158	23	5178	43	5198	63	5218	83	5238
4	5159	24	5179	44	5199	64	5219	84	5239
5	5160	25	5180	45	5200	65	5220	85	5240
6	5161	26	5181	46	5201	66	5221	86	5241
7	5162	27	5182	47	5202	67	5222	87	5242
8	5163	28	5183	48	5203	68	5223	88	5243
9	5164	29	5184	49	5204	69	5224	89	5244
10	5165	30	5185	50	5205	70	5225	90	5245
11	5166	31	5186	51	5206	71	5226		
12	5167	32	5187	52	5207	72	5227		
13	5168	33	5188	53	5208	73	5228		
14	5169	34	5189	54	5209	74	5229		
15	5170	35	5190	55	5210	75	5230		
16	5171	36	5191	56	5211	76	5231		
17	5172	37	5192	57	5212	77	5232		
18	5173	38	5193	58	5213	78	5233		
19	5174	39	5194	59	5214	79	5234		
U-NII Band 3									
Channel Number	Frequency (MHz)	Channel Number	Frequency (MHz)	Channel Number	Frequency (MHz)	Channel Number	Frequency (MHz)	Channel Number	Frequency (MHz)
0	5730	24	5754	48	5778	72	5802	96	5826
1	5731	25	5755	49	5779	73	5803	97	5827
2	5732	26	5756	50	5780	74	5804	98	5828
3	5733	27	5757	51	5781	75	5805	99	5829
4	5734	28	5758	52	5782	76	5806	100	5830
5	5735	29	5759	53	5783	77	5807	101	5831
6	5736	30	5760	54	5784	78	5808	102	5832
7	5737	31	5761	55	5785	79	5809	103	5833
8	5738	32	5762	56	5786	80	5810	104	5834
9	5739	33	5763	57	5787	81	5811	105	5835
10	5740	34	5764	58	5788	82	5812	106	5836
11	5741	35	5765	59	5789	83	5813	107	5837
12	5742	36	5766	60	5790	84	5814	108	5838
13	5743	37	5767	61	5791	85	5815	109	5839
14	5744	38	5768	62	5792	86	5816	110	5840
15	5745	39	5769	63	5793	87	5817	111	5841
16	5746	40	5770	64	5794	88	5818	112	5842
17	5747	41	5771	65	5795	89	5819	113	5843
18	5748	42	5772	66	5796	90	5820	114	5844
19	5749	43	5773	67	5797	91	5821	115	5845
20	5750	44	5774	68	5798	92	5822	116	5846
21	5751	45	5775	69	5799	93	5823	117	5847
22	5752	46	5776	70	5800	94	5824	118	5848
23	5753	47	5777	71	5801	95	5825		

**Channels List**

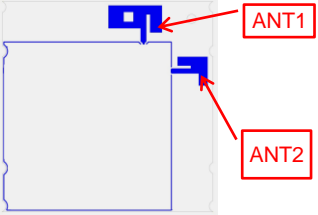
No.	Antenna Part Number	Manufacturer	Antenna Type	Frequency (MHz)	Max Gain (dBi)	
1.	Antenna_L (ANT 1)	SHENZHENSHI XINZHONGXIN TECHNOLOGY CO., LTD.	PCB Printing Antenna	5155-5245	1.23	
				5730-5850	1.93	
2.	Antenna_R (ANT 2)	SHENZHENSHI XINZHONGXIN TECHNOLOGY CO., LTD.	PCB Printing Antenna	5155-5245	1.96	
				5730-5850	1.92	

**This device contains 2 Antennas and the device does not support MIMO and only for antenna diversity**

## **FCC Statement**

### **Federal Communication Commission Interference Statement**

This equipment has been tested and found to comply with the limits for a Class B digital device, pursuant to Part 15 of the FCC Rules. These limits are designed to provide reasonable protection against harmful interference in a residential installation. This equipment generates, uses and can radiate radio frequency energy and, if not installed and used in accordance with the instructions, may cause harmful interference to radio communications. However, there is no guarantee that interference will not occur in a particular installation. If this equipment does cause harmful interference to radio or television reception, which can be determined by turning the equipment off and on, the user is encouraged to try to correct the interference by one of the following measures:

- Reorient or relocate the receiving antenna.
- Increase the separation between the equipment and receiver.
- Connect the equipment into an outlet on a circuit different from that to which the receiver is connected.
- Consult the dealer or an experienced radio/TV technician for help.

FCC Caution: Any changes or modifications not expressly approved by the party responsible for compliance could void the user's authority to operate this equipment.

This device complies with Part 15 of the FCC Rules. Operation is subject to the following two conditions:

- (1) This device may not cause harmful interference, and
- (2) This device must accept any interference received, including interference that may cause undesired operation.

Manufacturers integrating the Radio Module into other devices should note the following:

The device is compliant with part 15.247 and 15.407 of Title 47 of the FCC rules. If the Link Module is integrated into a new host product, the final host product still requires Part 15 Subpart B compliance testing with the modular transmitter installed.

## **IC Statement**

This Class B digital apparatus complies with Canadian ICES-003.

This device complies with Industry Canada license-exempt RSS standard(s). Operation is subject to the following two conditions:

- (1) this device may not cause interference, and
- (2) this device must accept any interference, including interference that may cause undesired operation of the device.

Cet appareil est conforme aux normes CNR exemptes de licence d'Industrie Canada. Le fonctionnement est soumis aux deux conditions suivantes :

- (1) cet appareil ne doit pas provoquer d'interférences et
- (2) cet appareil doit accepter toute interférence, y compris celles susceptibles de provoquer un fonctionnement non souhaité de l'appareil.

This Class B digital apparatus complies with Canadian ICES-003.

Cet appareil numérique de la classe B est conforme à la norme NMB-003 du Canada.

## **-Label and Compliance Information**

The final end product must be labeled in a visible area with the following:

"Contains FCC ID: BEJ-WL1BKT23",

"Contains IC: 2703H-WL1BKT23" .

"Contains FCC ID: BEJ-WL1BKR23",

"Contains IC: 2703H-WL1BKR23" .

The grantee's FCC ID can be used only when all FCC/ IC compliance requirements are met.

## **-RF exposure**

The module will install into mobile device such as Sound Bar

This equipment complies with FCC radiation exposure limits set forth for an uncontrolled environment. This equipment should be installed and operated with minimum distance 20cm between the radiator & your body.

## **Information on test modes and additional testing requirements**

-OEM integrator is still responsible for testing their end-product for any additional compliance requirements required with this module installed (for example, digital device emissions, PC peripheral requirements, additional transmitter in the host, etc.).

