

User Manual

Product name: Wireless Audio Module Product

Model: WL1BKR22 /WL1BKT22

Document No:

Version: V

Availability date: 2022-05-14

Edit	Review	Approve
Chao_Ma		Xiao_Chen

1. General specifications

WL1BKT22 and WL1BKR22 is a small size and low power wireless audio transmitter module, which is designed based on Beken CC258 MCU and Beken BK5813 RF Chip.

- Forced the 5.2/5.8 GHz GFSK modulation
- Size: 35MMx35MMx5.03mm
- PCB onboard antenna
- I2S digital audio interface
- Built-in MCU memory 256K, BUILT-IN MCU flash memory 192K
- I2C controls external devices
- I/O configuration
- Primary and secondary audio delay time <20ms
- Applications: Wireless speakers, wireless subwoofers, home theater

2. Module style

TX



RX



3. IO Definition

TX module PIN definition

Number	Definition	Description
1	VCC	POWER-UP 3.3V
2	GND	GND
3	GND	GND
4	NC	NC
5	NC	NC
6	GND	GND
7	IO	I2S_DATA_IN1
8	IO	I2S_DATA_IN2
9	GND	GND
10	IO	IIC_CLK
11	IO	IIC_DATA
12	NC	NC
13	IO	USB_DP
14	IO	USB_DN
15	MCU_USB	MCU_USB5V
16	NC	NC
17	NC	NC
18	IO	IO_PA1
19	IO	IO_PA2
20	NC	NC
21	IO	IO_PA4
22	NC	NC
23	NC	NC
24	IO	I2S_BCLK
25	GND	GND
26	IO	I2S_LRCLK

RX module PIN definition

Number	Definition	Description
1	VCC	POWER-UP 3.3V
2	GND	GND
3	GND	GND
4	IO	IO_PB0
5	IO	IO_P00
6	GND	GND
7	IO	I2S_DATA_OUT1
8	IO	I2S_DATA_OUT2
9	GND	GND
10	IIC	IIC_CLK
11	IO	IIC_DATA
12	NC	NC
13	IO	USB_DP
14	IO	USB_DN
15	MCU_USB	MCU_USB5V
16	NC	NC
17	NC	NC
18	IO	IO_PA1
19	IO	IO_PA2
20	IO	PA3
21	IO	IO_PA4
22	IO	IO_PA5
23	IO	IO_PA6
24	IO	I2S_BCLK
25	GND	GND
26	IO	I2S_LRCLK

4. The application UI

WL1BKT22 Operation description

- First: the module is powered on and started by 3.3V;
- Second: the host transmits the audio signal to the module through I2S;
- Third: THE MCU CC2538 on the module decodes the I2S audio signal, and then transmits the decoded audio signal to the BK5813 RF chip on the module through SPI;
- Fourth: the BK5813 RF chip on the module transmits the audio through wireless transmission;
- Fifth: there is I2C communication between the module and the host, both sides obtain the status and control through I2C;
- The product automatically stops the transmission if the information fails to be transferred or the operation fails.
- WL1BKT22 as the main device

WL1BKR22 Operation description

- First: The module is powered on and started by 3.3V;
- Second: The BK5813 RF chip on the module receives the audio signal transmitted by the transmitting module through wireless transmission;
- Third: MCU CC2538 on the module obtains the audio received by BK5813 through SPI;
- Fourth: MCU CC2538 decodes the acquired audio signal and transmits the audio to the power amplifier on the subwoofer power amplifier board through I2S;
- Fifth: There is I2C communication between the module and the subwoofer power amplifier board, initializing the power amplifier on the subwoofer power amplifier board, and I0 port communication between the module and the subwoofer power amplifier board, controlling the power amplifier switch and LED state display.
- WL1BKR22 is a client device controlled by the WL1BKT2.

WL1BKT22 device is classified as a master device.

WL1BKR22 is classified as a Client device under the control of the WL1BKT22.

The product automatically stops the transmission if the information fails to be transferred or the operation fails.

ISED RSS-247 (6.4) required by the technology

When there is no information to transmit or an operation fails, the device automatically discontinues transmission. After the transmission is discontinued, the TX module enters the reconnection state until it is reconnected or the power supply is switched off passively. After the transmission is discontinued, the RX module enters the RE-connection state for one minute, IF no connection, enters the standby mode after one minute.

FCC 15.407 (c) required by the technology

The device would automatically discontinue transmission if there is no information to transmit or if the operation fails. After the transmission is discontinued, the TX module enters the reconnection state until it is reconnected or the power supply is switched off passively. After the transmission is discontinued, the RX module enters the RE-connection state for one minute, IF no connection, enters the standby mode after one minute.

WL1BKT22 (TX module):

The reconnection state is TX will transmit control signal to RX for pair each other.

The TX re-try to transmit control signal to RX on complete frame or burst intervals until they connect successfully or power supply be off passively.

WL1BKR22 (RX module):

The connection state is no transmit data by RX module. It's only permit to transmit the information that is repetitive codes to TX on complete frame or burst intervals.

The standby mode is enter sleep mode to save consumption power.

On this mode, the RX doesn't transmit any information or data to TX.

The module-[WL1BKT22] is installed in the speaker, and the signal of the sound is provided through the HDMI or Optical ports of the TV audio products; When the speaker receive the sound signal, it will transmit the sound signal to another speaker (which is installed with the module-[WL1BKR22]).

Block diagram

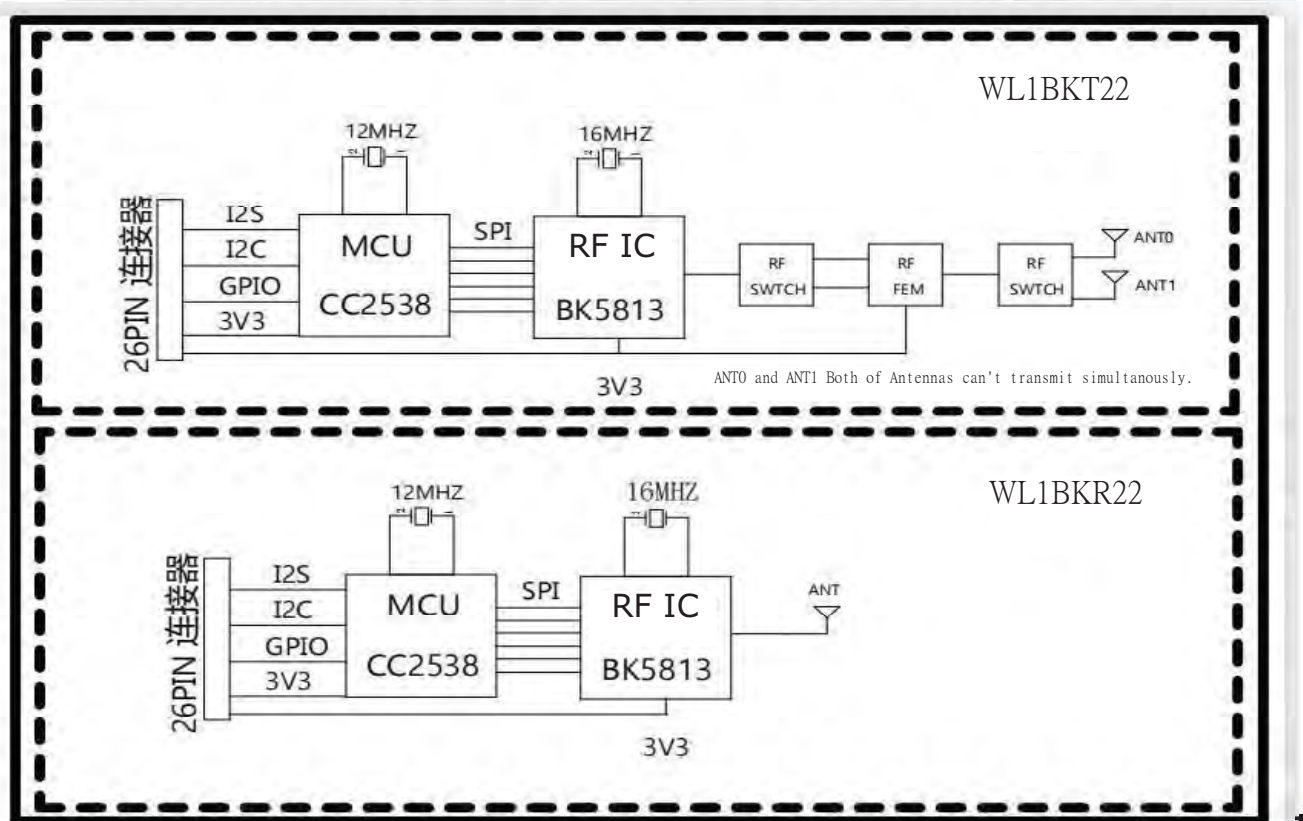

Note: Frequencies of this transmitter 5155-5228MHz and 5731-5828MHz.

Note: MCU built-in memory 256K, MCU built-in flash memory 192K and power supply regulation.

FCC Statement

Federal Communication Commission Interference Statement

This equipment has been tested and found to comply with the limits for a Class B digital device, pursuant to Part 15 of the FCC Rules. These limits are designed to provide reasonable protection against harmful interference in a residential installation. This equipment generates, uses and can radiate radio frequency energy and, if not installed and used in accordance with the instructions, may cause harmful interference to radio communications. However, there is no guarantee that interference will not occur in a particular installation. If this equipment does cause harmful interference to radio or television reception, which can be determined by turning the equipment off and on, the user is encouraged to try to correct the interference by one of the following measures:

- Reorient or relocate the receiving antenna.
- Increase the separation between the equipment and receiver.
- Connect the equipment into an outlet on a circuit different from that to which the receiver is connected.
- Consult the dealer or an experienced radio/TV technician for help.

FCC Caution: Any changes or modifications not expressly approved by the party responsible for compliance could void the user's authority to operate this equipment.

This device complies with Part 15 of the FCC Rules. Operation is subject to the following two conditions:

- (1) This device may not cause harmful interference, and
- (2) this device must accept any interference received, including interference that may cause undesired operation.

Manufacturers integrating the Radio Module into other devices should note the following:

The device is compliant with part 15.407 of Title 47 of the FCC rules. If the Link Module is integrated into a new host product, the final host product still requires Part 15 Subpart B compliance testing with the modular transmitter installed.

IC Statement

This Class B digital apparatus complies with Canadian ICES-003.

5150-5250MHz is limited to use indoor only

This device complies with Industry Canada license-exempt RSS standard(s). Operation is subject to the following two conditions:

- (1) this device may not cause interference, and
- (2) this device must accept any interference, including interference that may cause undesired operation of the device.

Cet appareil est conforme aux normes CNR exemptes de licence d'Industrie Canada. Le fonctionnement est soumis aux deux conditions suivantes :

- (1) cet appareil ne doit pas provoquer d'interférences et
- (2) cet appareil doit accepter toute interférence, y compris celles susceptibles de provoquer un fonctionnement non souhaité de l'appareil.

This Class B digital apparatus complies with Canadian ICES-003.

Cet appareil numérique de la classe B est conforme à la norme NMB-003 du Canada.

-Label and Compliance Information

The final end product must be labeled in a visible area with the following:

"Contains FCC ID: BEJ-WL1BKT22", "Contains FCC ID: BEJ-WL1BKR22",

"Contains IC: 2703H-WL1BKT22" "Contains IC: 2703H-WL1BKR22".

The grantee's FCC ID can be used only when all FCC/ IC compliance requirements are met.

-RF exposure

The module will install into mobile device such as Sound Bar

This equipment complies with FCC radiation exposure limits set forth for an uncontrolled environment. This equipment should be installed and operated with minimum distance 20cm between the radiator & your body.

Information on test modes and additional testing requirements-OEM integrator is still responsible for testing their end-product for any additional compliance requirements required with this module installed (for example, digital device emissions, PC peripheral requirements, additional transmitter in the host, etc.).

Antenna Specification**LG, WL1BKR22**

No.	Antenna Part Number	Manufacturer	Antenna Type	Frequency (MHz)	Max Gain(dBi)
1	RX Antenna	N/A	PCB Printing Antenna	5150	3.20
				5170	3.05
				5190	3.16
				5210	3.45
				5230	3.68
				5250	3.74
				5450	2.64
				5470	2.44
				5490	2.34
				5500	2.14
				5750	3.09
				5770	3.00
				5790	2.94
				5810	3.00
				5830	3.14
5850	3.05				

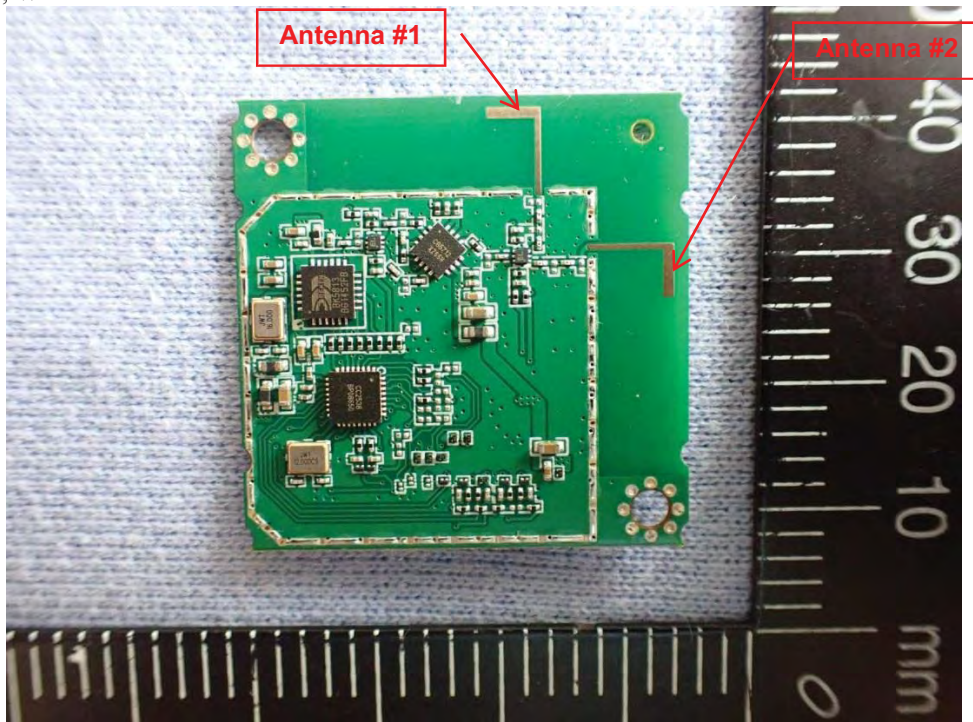

No.	Antenna Part Number	Manufacturer	Antenna Type	Frequency (MHz)	Max Gain(dBi)
1.	Antenna #1	N/A	PCB Printing Antenna	5150	2.66
				5170	2.87
				5190	2.94
				5210	3.25
				5230	3.23
				5250	3.11
				5450	2.98
				5470	2.98
				5490	2.77
				5500	2.59
				5750	2.38
				5770	2.38
				5790	2.48
				5810	2.33
5830	2.37				
5850	2.22				
No.	Antenna Part Number	Manufacturer	Antenna Type	Frequency (MHz)	Max Gain(dBi)
2.	Antenna #2	N/A	PCB Printing Antenna	5150	3.57
				5170	3.35
				5190	3.42
				5210	3.69
				5230	4.00
				5250	3.94
				5450	3.32
				5470	3.48
				5490	3.37
				5500	3.42
				5750	3.98
				5770	4.05
				5790	3.79
				5810	3.94
5830	4.20				
5850	4.09				