

TEST REPORT

of

FCC Part 15 Subpart C §15.247

FCC ID: BEJ-LCW006

Equipment Under Test : WLAN Module
Model Name : LCW-006
Applicant : LG Electronics USA
Manufacturer : LG Electronics Inc.
Date of Receipt : 2017.06.13
Date of Test(s) : 2017.06.20 ~ 2017.07.20
Date of Issue : 2017.07.24

In the configuration tested, the EUT complied with the standards specified above.

Tested By:



Date:

2017.07.24

Jaeha Chung

Technical
Manager:



Date:

2017.07.24

Hyunchae You

The results shown in this test report refer only to the sample(s) tested unless otherwise stated. This test report cannot be reproduced, except in full, without prior written permission of the Company. This test report does not assure KOLAS accreditation.

SGS Korea Co., Ltd. (Gunpo Laboratory) 4, LS-ro 182beon-gil, Gunpo-si, Gyeonggi-do, Korea, 15807 <http://www.sgsgroup.kr>

RTT5041-19(2017.07.10)(0)

Tel. +82 31 428 5700 / Fax. +82 31 427 2370

A4(210 mm x 297 mm)

INDEX

Table of contents

| | |
|--|----|
| 1. General Information ----- | 3 |
| 2. Transmitter Radiated Spurious Emissions and Conducted Spurious Emission ----- | 7 |
| 3. 6 dB Bandwidth ----- | 67 |
| 4. Maximum Peak Conducted Output Power ----- | 75 |
| 5. Power Spectral Density ----- | 78 |
| 6. AC Power Line Conducted Emission ----- | 86 |
| 7. Antenna Requirement ----- | 90 |

The results shown in this test report refer only to the sample(s) tested unless otherwise stated. This test report cannot be reproduced, except in full, without prior written permission of the Company. This test report does not assure KOLAS accreditation.

SGS Korea Co., Ltd. (Gunpo Laboratory) 4, LS-ro 182beon-gil, Gunpo-si, Gyeonggi-do, Korea, 15807 <http://www.sgsgroup.kr>

RTT5041-19(2017.07.10)(0)

Tel. +82 31 428 5700 / Fax. +82 31 427 2370

A4(210 mm x 297 mm)

1. General Information

1.1. Testing Laboratory

SGS Korea Co., Ltd. (Gunpo Laboratory)

- Wireless Div. 2FL, 10-2, LS-ro 182beon-gil, Gunpo-si, Gyeonggi-do, Korea, 15807

All SGS services are rendered in accordance with the applicable SGS conditions of service available on request and accessible at <http://www.sgs.com/en/Terms-and-Conditions.aspx>.

Phone No. : +82 31 688 0901

Fax No. : +82 31 688 0921

1.2. Details of Applicant

Applicant : LG Electronics USA

Address : 1000 Sylvan Avenue Englewood Cliffs New Jersey United States 07632

Contact Person : Jung, Hyeon-Soo

Phone No. : +82 55 260 3966

1.3. Description of EUT

| | |
|-----------------------------|---|
| Kind of Product | WLAN Module |
| Model Name | LCW-006 |
| Power Supply | DC 5.0 V |
| Frequency Range | 2 412 MHz ~ 2 462 MHz (11b/g/n_HT20), 2 422 MHz ~ 2 452 MHz (11n_HT40) |
| Modulation Technique | DSSS, OFDM |
| Number of Channels | 11 channels (11b/g/n_HT20), 7 channels (11n_HT40) |
| Antenna Type | PCB Pattern Antenna |
| Antenna Gain | 1.15 dBi |
| H/W Version | V1.0 |
| S/W Version | V1.0 |

1.4 Declaration of manufacturer

- 5 GHz WLAN is disabled by manufacturer.

The results shown in this test report refer only to the sample(s) tested unless otherwise stated. This test report cannot be reproduced, except in full, without prior written permission of the Company. This test report does not assure KOLAS accreditation.

SGS Korea Co., Ltd. (Gunpo Laboratory) 4, LS-ro 182beon-gil, Gunpo-si, Gyeonggi-do, Korea, 15807 <http://www.sgsgroup.kr>

RTT5041-19(2017.07.10)(0)

Tel. +82 31 428 5700 / Fax. +82 31 427 2370

A4(210 mm x 297 mm)

1.5. Test Equipment List

| Equipment | Manufacturer | Model | S/N | Cal. Date | Cal. Interval | Cal. Due |
|-------------------|-----------------------------|--------------------------------------|---------------------------|---------------|---------------|---------------|
| Signal Generator | R&S | SMR40 | 100272 | Jun. 16, 2017 | Annual | Jun. 16, 2018 |
| Signal Generator | R&S | SMBV100A | 255834 | Jun. 15, 2017 | Annual | Jun. 15, 2018 |
| Spectrum Analyzer | R&S | FSV30 | 103102 | Jun. 10, 2017 | Annual | Jun. 10, 2018 |
| Spectrum Analyzer | R&S | FSW67 | 103242 | Jan. 03, 2017 | Annual | Jan. 03, 2018 |
| Spectrum Analyzer | Agilent | N9030A | US51350132 | Sep. 23, 2016 | Annual | Sep. 23, 2017 |
| Attenuator | AEROFLEX / INMET | 18N-20 dB | 2 | Feb. 24, 2017 | Annual | Feb. 24, 2018 |
| High Pass Filter | Wainwright Instrument GmbH | WHK3.0/18G-6SS | 344 | May 28, 2017 | Annual | May 28, 2018 |
| High Pass Filter | Wainwright Instrument GmbH | WHNX7.5/26.5G-6SS | 11 | May 28, 2017 | Annual | May 28, 2018 |
| Low Pass Filter | Mini-Circuits | NLP-1200+ | V 8979400903-2 | Feb. 21, 2017 | Annual | Feb. 21, 2018 |
| Power Sensor | R&S | NRP-Z81 | 100669 | Feb. 23, 2017 | Annual | Feb. 23, 2018 |
| DC Power Supply | Agilent | U8002A | MY50060028 | Mar. 16, 2017 | Annual | Mar. 16, 2018 |
| Preamplifier | H.P. | 8447F | 2944A03909 | Aug. 11, 2016 | Annual | Aug. 11, 2017 |
| Preamplifier | R&S | SCU-18 | 10117 | Apr. 08, 2017 | Annual | Apr. 08, 2018 |
| Preamplifier | MITEQ Inc. | JS44-18004000-35-8P | 1546891 | May 15, 2017 | Annual | May 15, 2018 |
| Loop Antenna | Schwarzbeck Mess-Elektronik | FMZB 1519 | 1519-039 | Aug. 19, 2015 | Biennial | Aug. 19, 2017 |
| Bilog Antenna | Schwarzbeck Mess-Elektronik | VULB9163 | 437 | Oct. 21, 2016 | Biennial | Oct. 21, 2018 |
| Horn Antenna | R&S | HF906 | 100326 | Feb. 01, 2016 | Biennial | Feb. 01, 2018 |
| Horn Antenna | Schwarzbeck Mess-Elektronik | BBHA 9170 | BBHA9170431 | Aug. 25, 2016 | Biennial | Aug. 25, 2018 |
| Antenna Master | INNCO systems GmbH | MA4640-XP-ET | MA4640/536/383 30516/L | N.C.R. | N/A | N.C.R. |
| Controller | INNCO systems GmbH | CONTROLLER CO3000-4P | CO3000/963/383 30516/L | N.C.R. | N/A | N.C.R. |
| Turn Table | INNCO systems GmbH | DS 1200 S | N/A | N.C.R. | N/A | N.C.R. |
| Test Receiver | R&S | ESU26 | 100109 | Feb. 17, 2017 | Annual | Feb. 17, 2018 |
| Anechoic Chamber | SY Corporation | L x W x H (9.6 m x 6.4 m x 6.6 m) | N/A | N.C.R. | N/A | N.C.R. |

Note;

- The equipment calibrated during the test period was used after finished the calibration.

The results shown in this test report refer only to the sample(s) tested unless otherwise stated. This test report cannot be reproduced, except in full, without prior written permission of the Company. This test report does not assure KOLAS accreditation.

1.6. Summary of Test Results

The EUT has been tested according to the following specifications:

| APPLIED STANDARD: FCC Part15 Subpart C | | |
|--|--|----------|
| Standard section | Test Item(s) | Result |
| 15.205(a) 15.209 15.247(d) | Transmitter Radiated Spurious Emissions Conducted Spurious Emission | Complied |
| 15.247(a)(2) | 6 dB Bandwidth | Complied |
| 15.247(b)(3) | Maximum Peak Conducted Output Power | Complied |
| 15.247(e) | Power Spectral Density | Complied |
| 15.207 | AC Power Line Conducted Emission | Complied |

1.7. Test Procedure(s)

The measurement procedures described in the American National Standard of Procedure for Compliance Testing of unlicensed Wireless Devices (ANSI C63.10-2013) and the guidance provided in KDB 558074 D01 DTS Meas Guidance v04 were used in the measurement of the DUT.

1.8. Sample calculation

Where relevant, the following sample calculation is provided:

1.8.1. Conducted test

Offset value (dB) = Attenuator (dB) + Cable loss (dB)

1.8.2. Radiation test

Field strength level (dB μ V/m) = Measured level (dB μ V) + Antenna factor (dB) + Cable loss (dB) - Amplifier gain (dB)

1.9. Test report revision

| Revision | Report number | Date of Issue | Description |
|----------|----------------------|---------------|-------------|
| 0 | F690501/RF-RTL011578 | 2017.07.24 | Initial |

The results shown in this test report refer only to the sample(s) tested unless otherwise stated. This test report cannot be reproduced, except in full, without prior written permission of the Company. This test report does not assure KOLAS accreditation.

1.10. Duty Cycle of EUT

Regarding to KDB 558074 D01 DTS Meas Guidance v04, 6.0, the maximum duty cycles of all modes were investigated and set the spectrum analyzer as below;

Set RBW \geq OBW if possible; otherwise, set RBW to the largest available value, Set VBW \geq RBW. Set detector = peak or average. The zero-span measurement method shall not be used unless both RBW and VBW are $> 50/T$ and the number of sweep points across duration T exceeds 100.

| Mode | Data Rate | Duty Cycle (%) | Correction factor (dB) |
|----------|-----------|----------------|------------------------|
| 11b | 1 Mbps | 100 | 0 |
| 11g | 6 Mbps | 100 | 0 |
| 11n_HT20 | MCS0 | 100 | 0 |
| 11n_HT40 | MCS0 | 100 | 0 |

Remark:

1. As measured duty cycles of EUT, all of mode and data rate keep constant period and are converted to log scale (power averaging) to compensate correction factor to result of average test items.
2. Duty Cycle (%) = (Tx on time / Tx on + off time) x 100
3. Correction factor (dB) = 10 log (1 / Duty Cycle)

The results shown in this test report refer only to the sample(s) tested unless otherwise stated. This test report cannot be reproduced, except in full, without prior written permission of the Company. This test report does not assure KOLAS accreditation.

2. Transmitter Radiated Spurious Emissions and Conducted Spurious Emission

2.1. Test Setup

2.1.1. Transmitter Radiated Spurious Emissions

The diagram below shows the test setup that is utilized to make the measurements for emission from 9 kHz to 30 MHz.

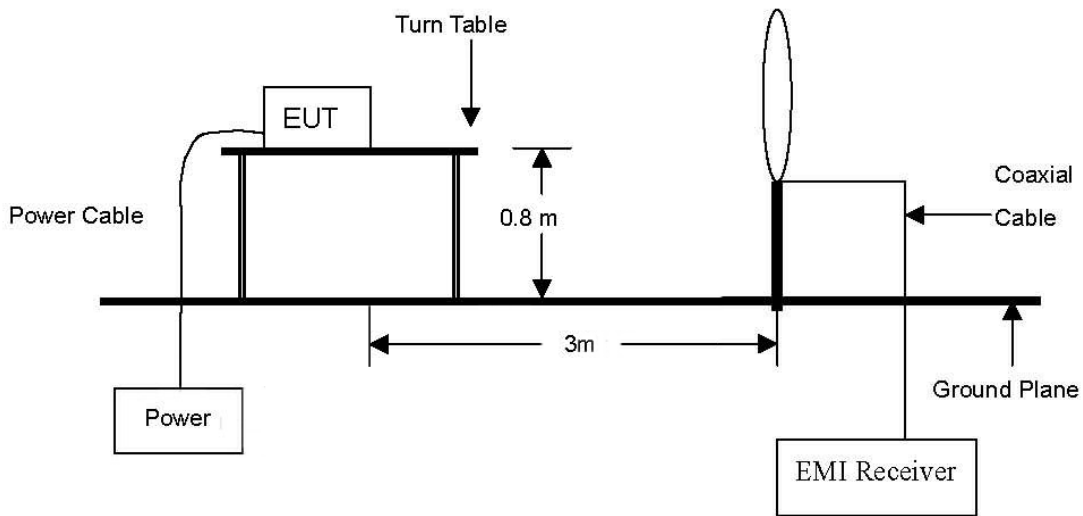

The results shown in this test report refer only to the sample(s) tested unless otherwise stated. This test report cannot be reproduced, except in full, without prior written permission of the Company. This test report does not assure KOLAS accreditation.

The diagram below shows the test setup that is utilized to make the measurements for emission from 30 MHz to 1 GHz.

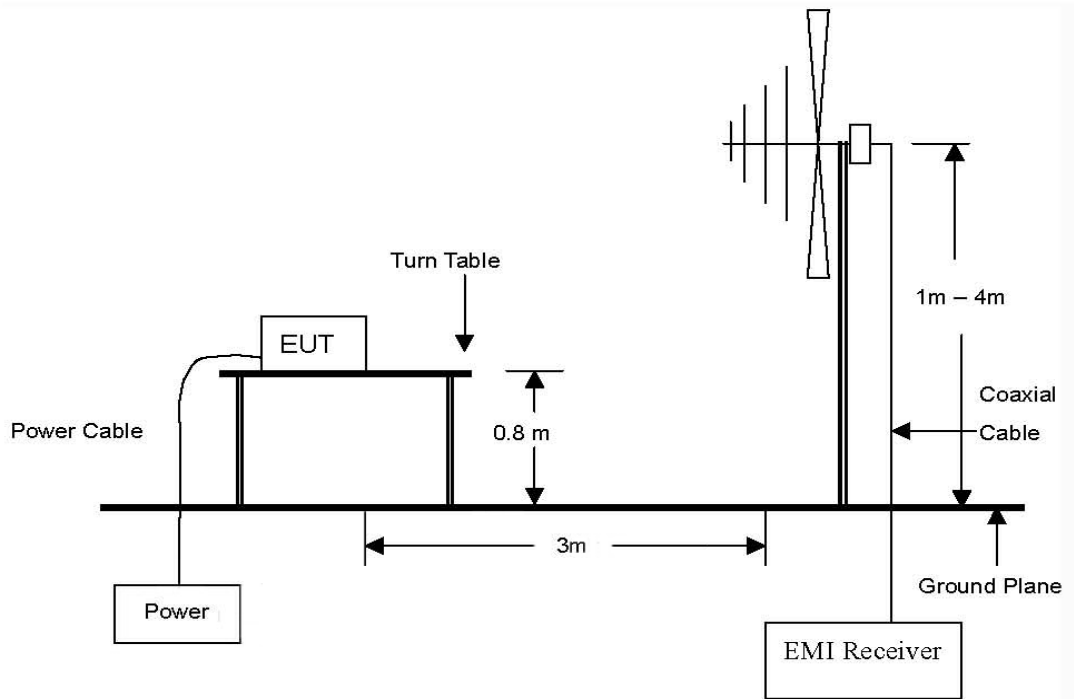

The diagram below shows the test setup that is utilized to make the measurements for emission. The spurious emissions were investigated from 1 GHz to the 10th harmonic of the highest fundamental frequency or 40 GHz, whichever is lower.

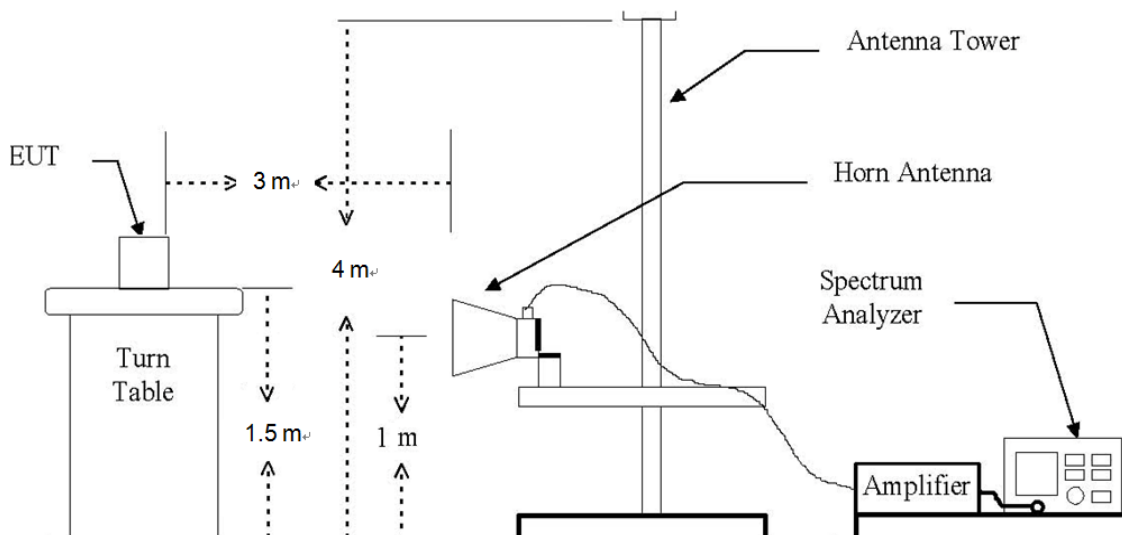

The results shown in this test report refer only to the sample(s) tested unless otherwise stated. This test report cannot be reproduced, except in full, without prior written permission of the Company. This test report does not assure KOLAS accreditation.

2.1.2. Conducted Spurious Emission



2.2. Limit

§15.247(d), in any 100 kHz bandwidth outside the frequency band in which the spread spectrum or digitally modulated intentional radiator is operating, the radio frequency power that is produced by the intentional radiator shall be at least 20 dB below that in the 100 kHz bandwidth within the band that contains the highest level of the desired power, based on either an RF conducted or a radiated measurement, provided the transmitter demonstrates compliance with the peak conducted power limits. If the transmitter complies with the conducted power limits based on the use of RMS averaging over a time interval, as permitted under paragraph (b)(3) of this section, the attenuation required under this paragraph shall be 30 dB instead of 20 dB. Attenuation below the general limits specified in section §15.209(a) is not required. In addition, radiated emission which in the restricted band, as define in section §15.205(a), must also comply the radiated emission limits specified in section §15.209(a) (see §15.205(c)).

§15.209(a), except as provided elsewhere in this subpart, the emissions from an intentional radiator shall not exceed the field strength levels specified in the following table :

| Frequency (MHz) | Measurement Distance (meters) | Field Strength (dBμV/m) | Field Strength (μV/m) |
|-----------------|-------------------------------|-------------------------|-----------------------|
| 0.009 - 0.490 | 300 | 20 log (2 400/F(kHz)) | 2 400/F(kHz) |
| 0.490 - 1.705 | 30 | 20 log (24 000/F(kHz)) | 24 000/F(kHz) |
| 1.705 - 30.0 | 30 | 29.54 | 30 |
| 30 - 88 | 3 | 40.0 | 100** |
| 88 - 216 | 3 | 43.5 | 150** |
| 216 - 960 | 3 | 46.0 | 200** |
| Above 960 | 3 | 54.0 | 500 |

** Except as provided in paragraph (g), fundamental emissions from intentional radiators operating under this Section shall not be located in the frequency bands 54-72 MHz, 76-88 MHz, 174-216 MHz or 470-806 MHz. However, operation within these frequency bands is permitted under other sections of this Part, e.g., Sections §15.231 and §15.241.

The results shown in this test report refer only to the sample(s) tested unless otherwise stated. This test report cannot be reproduced, except in full, without prior written permission of the Company. This test report does not assure KOLAS accreditation.

2.3. Test Procedures

Radiated emissions from the EUT were measured according to the dictates in section 11.0 & 12.0 of KDB 558074 D01 DTS Meas Guidance v04 and ANSI C63.10-2013.

2.3.1. Test Procedures for emission below 30 MHz

1. The EUT was placed on the top of a rotating table 0.8 meters above the ground at a 3 meter anechoic chamber test site. The table was rotated 360 degrees to determine the position of the highest radiation.
2. Then antenna is a loop antenna is fixed at one meter above the ground to determine the maximum value of the field strength. Both parallel and perpendicular of the antenna are set to make the measurement.
3. For each suspected emission, the EUT was arranged to its worst case and then the table was turned from 0 degrees to 360 degrees to find the maximum reading.
4. The test-receiver system was set to average or quasi peak detect function and Specified Bandwidth with Maximum Hold Mode.

Note;

Although these tests were performed other than open field test site, adequate comparison measurements were confirmed against 30 meter open field test site. Therefore sufficient tests were made to demonstrate that the alternative site produces results that correlate with the ones of tests made in an open field based on KDB 414788 D01 Radiated Test Site v01.

2.3.2. Test Procedures for emission from above 30 MHz

1. The EUT was placed on the top of a rotating table 0.8 meters above the ground at a 3 meter anechoic chamber test site below 1 GHz and 1.5 meters above the ground at a 3 meter anechoic chamber test site above 1 GHz. The table was rotated 360 degrees to determine the position of the highest radiation.
2. During performing radiated emission below 1 GHz, the EUT was set 3 meters away from the interference receiving antenna, which was mounted on the top of a variable-height antenna tower. During performing radiated emission above 1 GHz, the EUT was set 3 meter away from the interference-receiving antenna.
3. The antenna is a bi-log antenna, a horn antenna and its height is varied from one meter to four meters above the ground to determine the maximum value of the field strength. Both horizontal and vertical polarizations of the antenna are set to make the measurement.
4. For each suspected emission, the EUT was arranged to its worst case and then the antenna was tuned to heights from 1 meter to 4 meters and the table was turned from 0 degrees to 360 degrees to find the maximum reading.
5. The test-receiver system was set to Peak Detect Function and Specified Bandwidth with Maximum Hold Mode.
6. If the emission level of the EUT in peak mode was 10 dB lower than the limit specified, then testing could be stopped and the peak values of the EUT would be reported. Otherwise the emissions that did not have 10 dB margin would be re-tested one by one using peak, quasi-peak or average method as specified and then reported in a data sheet.

The results shown in this test report refer only to the sample(s) tested unless otherwise stated. This test report cannot be reproduced, except in full, without prior written permission of the Company. This test report does not assure KOLAS accreditation.

NOTE;

All data rates and modes were investigated for radiated spurious emissions. Only the radiated emissions of the configuration that produced the worst case emissions are reported in this section.

1. Unwanted Emissions into Non-Restricted Frequency Bands

- The Reference Level Measurement refer to section 11.2
Set analyzer center frequency to DTS channel center frequency, SPAN ≥ 1.5 times the DTS bandwidth, the RBW = 100 kHz and VBW $\geq 3 \times$ RBW, Detector = Peak, Sweep time = Auto couple, Trace mode = Max hold.
- Unwanted Emissions Level Measurement refer to section 11.3
Set the center frequency and span to encompass frequency range to be measured, the RBW = 100 kHz and VBW $\geq 3 \times$ RBW, Detector = Peak, Sweep time = Auto couple, Trace mode = Max hold.

2. Unwanted Emissions into Restricted Frequency Bands

- Peak Power measurement procedure refer to section 12.2.4
Set RBW = as specified in Table 1, VBW $\geq 3 \times$ RBW, Detector = Peak, Sweep time = auto, Trace mode = Max hold.

Table 1- RBW as a function of frequency

| Frequency | RBW |
|----------------|---------------|
| 9 – 150 kHz | 200 – 300 Hz |
| 0.15 – 30 MHz | 9 – 10 kHz |
| 30 – 1 000 MHz | 100 – 120 kHz |
| > 1 000 MHz | 1 MHz |

- Average Power measurements procedure refer to section 12.2.5.2
The EUT shall be configured to operate at the maximum achievable duty cycle.
Measure the duty cycle, x, of the transmitter output signal as described in section 6.0.
Set RBW = 1 MHz, VBW $\geq 3 \times$ RBW, Detector = RMS, if span / (# of points in sweep) \leq (RBW/2).
Satisfying this condition may require increasing the number of points in the sweep or reducing the span. If this condition cannot be satisfied then the detector mode shall be set to peak.

Averaging type = power (i.e., RMS).

As an alternative the detector and averaging type may be set for linear voltage averaging.
Some instruments require linear display mode in order to use linear voltage averaging. Log or dB averaging shall not be used. Sweep time = auto, Perform a trace average of at least 100 traces.

A correction factor shall be added to the measurement results prior to comparing to the emission limit in order to compute the emission level that would have been measured had the test been performed at 100 percent duty cycle. The correction factor is computed as follows:

- 1) If power averaging (RMS) mode was used in step f), then the applicable correction factor is $10 \log(1/x)$, where x is the duty cycle.
- 3) If a specific emission is demonstrated to be continuous (≥ 98 % duty cycle) rather than turning on and off with the transmit cycle, then no duty cycle correction is required for that emission.

3. To get a maximum emission level from the EUT, the EUT is manipulated through three orthogonal planes (X, Y, Z). Worst orthogonal plan of EUT is **Y – axis** during radiation test.

The results shown in this test report refer only to the sample(s) tested unless otherwise stated. This test report cannot be reproduced, except in full, without prior written permission of the Company. This test report does not assure KOLAS accreditation.

2.3.3. Test Procedures for Conducted Spurious Emissions

All data rates and modes were investigated for radiated spurious emissions. Only the radiated emissions of the configuration that produced the worst case emissions are reported in this section.

Per the guidance of KDB 558074 D01 DTS Meas Guidance v04, section 11.1 & 11.2 & 11.3, the reference level for out of band emissions is established from the plots of this section since the band edge emissions are measured with a RBW of 100 kHz. This reference level is then used as the limit in subsequent plots for out of band spurious emissions shown in section 2.4.3. The limit for out of band spurious emission at the band edge is 20 dB below the fundamental emission level measured in a 100 kHz bandwidth.

1. Conducted Emissions at Band Edge

- The Measurement refer to section 11.2

Set the center frequency and span to encompass frequency range to be measured, the RBW = 100 kHz and VBW $\geq 3 \times$ RBW, Detector = Peak, Sweep time = Auto couple, Trace mode = Max hold, Ensure that the number of measurement points \geq span/RBW, The trace was allowed to stabilize.

2. Conducted Spurious Emissions

- The Measurement refer to section 11.3

Start frequency was set to 9 kHz and stop frequency was set to 25 GHz (separated into two plots per channel), RBW = 100 kHz, VBW $\geq 3 \times$ RBW, Detector = Peak, Sweep time = Auto couple, Trace = Max hold, The trace was allowed to stabilize.

3. TDF function

- For plots showing conducted spurious emissions from 9 kHz to 25 GHz, all path loss of wide frequency range was investigated and compensated to spectrum analyzer as TDF function. So, the reading values shown in plots were final result.

The results shown in this test report refer only to the sample(s) tested unless otherwise stated. This test report cannot be reproduced, except in full, without prior written permission of the Company. This test report does not assure KOLAS accreditation.

2.4. Test Results

Ambient temperature : (23 ± 1) °C
 Relative humidity : 47 % R.H.

2.4.1. Radiated Spurious Emission below 1 000 MHz

The frequency spectrum from 9 kHz to 1 000 MHz was investigated.

| Radiated Emissions | | | Ant | Correction Factors | | Total | Limit | |
|--------------------|----------------------|-------------|------|--------------------|---------------|-----------------------|----------------------|-------------|
| Frequency (MHz) | Reading (dB μ V) | Detect Mode | Pol. | AF (dB/m) | AMP + CL (dB) | Actual (dB μ V/m) | Limit (dB μ V/m) | Margin (dB) |
| 240.05 | 53.50 | Peak | H | 11.90 | -24.95 | 40.45 | 46.00 | 5.55 |
| 243.04 | 52.70 | Peak | V | 11.96 | -24.91 | 39.75 | 46.00 | 6.25 |
| 431.99 | 49.00 | Quasi Peak | V | 16.08 | -24.75 | 40.33 | 46.00 | 5.67 |
| 499.84 | 51.20 | Peak | H | 16.90 | -24.74 | 43.36 | 46.00 | 2.64 |
| 766.47 | 41.90 | Peak | H | 20.50 | -23.59 | 38.81 | 46.00 | 7.19 |
| 799.49 | 39.70 | Peak | V | 20.39 | -23.42 | 36.67 | 46.00 | 9.33 |
| Above 800.00 | Not detected | - | - | - | - | - | - | - |

Remark;

- Spurious emissions for all channels were investigated and almost the same below 1 GHz.
- Reported spurious emissions are in **11b / 1Mbps / High channel** as worst case among other modes.
- Radiated spurious emission measurement as below.
 (Actual = Reading + AF + AMP + CL)
- According to §15.31(o), emission levels are not report much lower than the limits by over 20 dB.

Test plot

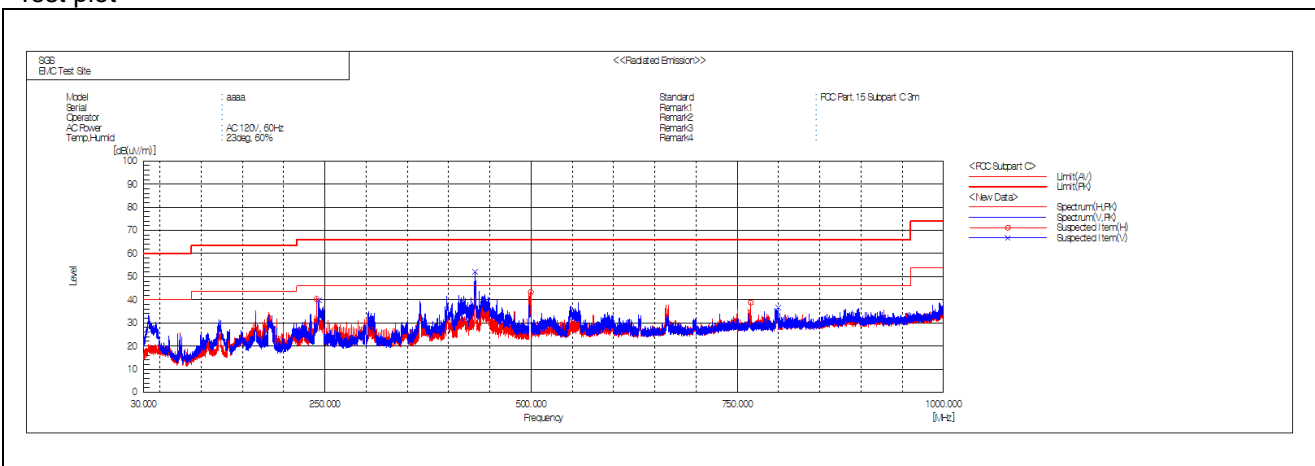

The results shown in this test report refer only to the sample(s) tested unless otherwise stated. This test report cannot be reproduced, except in full, without prior written permission of the Company. This test report does not assure KOLAS accreditation.

2.4.2. Radiated Spurious Emission above 1 000 MHz

The frequency spectrum above 1 000 MHz was investigated. All reading values are peak and average values.

DSSS : 802.11b (1 Mbps)

Low Channel (2 412 MHz)

| Radiated Emissions | | | Ant. | Correction Factors | | | Total | Limit | |
|--------------------|----------------------|-------------|------|--------------------|---------|-----------|-----------------------|----------------------|-------------|
| Frequency (MHz) | Reading (dB μ V) | Detect Mode | Pol. | AF (dB/m) | CL (dB) | Duty (dB) | Actual (dB μ V/m) | Limit (dB μ V/m) | Margin (dB) |
| *2 310.00 | 18.79 | Peak | H | 28.07 | 6.92 | - | 53.78 | 74.00 | 20.22 |
| *2 310.00 | 8.13 | Average | H | 28.07 | 6.92 | - | 43.12 | 54.00 | 10.88 |
| *2 389.43 | 22.13 | Peak | H | 28.15 | 6.97 | - | 57.25 | 74.00 | 16.75 |
| *2 389.43 | 11.66 | Average | H | 28.15 | 6.97 | - | 46.78 | 54.00 | 7.22 |
| *2 390.00 | 21.82 | Peak | H | 28.15 | 6.97 | - | 56.94 | 74.00 | 17.06 |
| *2 390.00 | 11.21 | Average | H | 28.15 | 6.97 | - | 46.33 | 54.00 | 7.67 |

| Radiated Emissions | | | Ant. | Correction Factors | | | Total | Limit | |
|--------------------|----------------------|-------------|------|--------------------|-------------|-----------|-----------------------|----------------------|-------------|
| Frequency (MHz) | Reading (dB μ V) | Detect Mode | Pol. | AF (dB/m) | AMP+CL (dB) | Duty (dB) | Actual (dB μ V/m) | Limit (dB μ V/m) | Margin (dB) |
| *4 824.00 | 50.20 | Peak | H | 32.71 | -28.14 | - | 54.77 | 74.00 | 19.23 |
| *4 824.02 | 47.27 | Average | H | 32.71 | -28.14 | - | 51.84 | 54.00 | 2.16 |
| Above 4 900.00 | Not detected | - | - | - | - | - | - | - | - |

The results shown in this test report refer only to the sample(s) tested unless otherwise stated. This test report cannot be reproduced, except in full, without prior written permission of the Company. This test report does not assure KOLAS accreditation.

Middle Channel (2 437 MHz)

| Radiated Emissions | | | Ant. | Correction Factors | | | Total | Limit | |
|--------------------|----------------------|-------------|------|--------------------|-------------|-----------|-----------------------|----------------------|-------------|
| Frequency (MHz) | Reading (dB μ V) | Detect Mode | Pol. | AF (dB/m) | AMP+CL (dB) | Duty (dB) | Actual (dB μ V/m) | Limit (dB μ V/m) | Margin (dB) |
| *4 874.17 | 50.03 | Peak | H | 32.84 | -28.02 | - | 54.85 | 74.00 | 19.15 |
| *4 873.98 | 47.69 | Average | H | 32.84 | -28.02 | - | 52.51 | 54.00 | 1.49 |
| Above 4 900.00 | Not detected | - | - | - | - | - | - | - | - |

High Channel (2 462 MHz)

| Radiated Emissions | | | Ant. | Correction Factors | | | Total | Limit | |
|--------------------|----------------------|-------------|------|--------------------|---------|-----------|-----------------------|----------------------|-------------|
| Frequency (MHz) | Reading (dB μ V) | Detect Mode | Pol. | AF (dB/m) | CL (dB) | Duty (dB) | Actual (dB μ V/m) | Limit (dB μ V/m) | Margin (dB) |
| *2 483.50 | 21.24 | Peak | H | 28.24 | 7.27 | - | 56.75 | 74.00 | 17.25 |
| *2 483.50 | 10.18 | Average | H | 28.24 | 7.27 | - | 45.69 | 54.00 | 8.31 |
| *2 488.64 | 21.81 | Peak | H | 28.25 | 7.24 | - | 57.30 | 74.00 | 16.70 |
| *2 483.68 | 11.65 | Average | H | 28.24 | 7.27 | - | 47.16 | 54.00 | 6.84 |
| *2 500.00 | 20.60 | Peak | H | 28.26 | 7.19 | - | 56.05 | 74.00 | 17.95 |
| *2 500.00 | 10.20 | Average | H | 28.26 | 7.19 | - | 45.65 | 54.00 | 8.35 |

| Radiated Emissions | | | Ant. | Correction Factors | | | Total | Limit | |
|--------------------|----------------------|-------------|------|--------------------|-------------|-----------|-----------------------|----------------------|-------------|
| Frequency (MHz) | Reading (dB μ V) | Detect Mode | Pol. | AF (dB/m) | AMP+CL (dB) | Duty (dB) | Actual (dB μ V/m) | Limit (dB μ V/m) | Margin (dB) |
| *4 924.18 | 44.56 | Peak | H | 32.98 | -27.58 | - | 49.96 | 74.00 | 24.04 |
| *4 924.02 | 40.02 | Average | H | 32.98 | -27.58 | - | 45.42 | 54.00 | 8.58 |
| Above 5 000.00 | Not detected | - | - | - | - | - | - | - | - |

The results shown in this test report refer only to the sample(s) tested unless otherwise stated. This test report cannot be reproduced, except in full, without prior written permission of the Company. This test report does not assure KOLAS accreditation.

OFDM: 802.11g (6 Mbps)

Low Channel (2 412 MHz)

| Radiated Emissions | | | Ant. | Correction Factors | | | Total | Limit | |
|--------------------|----------------------|-------------|------|--------------------|---------|-----------|-----------------------|----------------------|-------------|
| Frequency (MHz) | Reading (dB μ V) | Detect Mode | Pol. | AF (dB/m) | CL (dB) | Duty (dB) | Actual (dB μ V/m) | Limit (dB μ V/m) | Margin (dB) |
| *2 310.00 | 17.89 | Peak | H | 28.07 | 6.92 | - | 52.88 | 74.00 | 21.12 |
| *2 310.00 | 8.39 | Average | H | 28.07 | 6.92 | - | 43.38 | 54.00 | 10.62 |
| *2 389.54 | 28.52 | Peak | H | 28.15 | 6.97 | - | 63.64 | 74.00 | 10.36 |
| *2 389.87 | 14.74 | Average | H | 28.15 | 6.97 | - | 49.86 | 54.00 | 4.14 |
| *2 390.00 | 30.26 | Peak | H | 28.15 | 6.97 | - | 65.38 | 74.00 | 8.62 |
| *2 390.00 | 14.14 | Average | H | 28.15 | 6.97 | - | 49.26 | 54.00 | 4.74 |

| Radiated Emissions | | | Ant. | Correction Factors | | | Total | Limit | |
|--------------------|----------------------|-------------|------|--------------------|-------------|-----------|-----------------------|----------------------|-------------|
| Frequency (MHz) | Reading (dB μ V) | Detect Mode | Pol. | AF (dB/m) | AMP+CL (dB) | Duty (dB) | Actual (dB μ V/m) | Limit (dB μ V/m) | Margin (dB) |
| *4 826.20 | 46.61 | Peak | H | 32.71 | -28.16 | - | 51.16 | 74.00 | 22.84 |
| *4 825.60 | 35.31 | Average | H | 32.71 | -28.16 | - | 39.86 | 54.00 | 14.14 |
| Above 4 900.00 | Not detected | - | - | - | - | - | - | - | - |

Middle Channel (2 437 MHz)

| Radiated Emissions | | | Ant. | Correction Factors | | | Total | Limit | |
|--------------------|----------------------|-------------|------|--------------------|-------------|-----------|-----------------------|----------------------|-------------|
| Frequency (MHz) | Reading (dB μ V) | Detect Mode | Pol. | AF (dB/m) | AMP+CL (dB) | Duty (dB) | Actual (dB μ V/m) | Limit (dB μ V/m) | Margin (dB) |
| *4 875.50 | 44.97 | Peak | H | 32.85 | -28.02 | - | 49.80 | 74.00 | 24.20 |
| *4 874.30 | 34.09 | Average | H | 32.84 | -28.02 | - | 38.91 | 54.00 | 15.09 |
| Above 4 900.00 | Not detected | - | - | - | - | - | - | - | - |

The results shown in this test report refer only to the sample(s) tested unless otherwise stated. This test report cannot be reproduced, except in full, without prior written permission of the Company. This test report does not assure KOLAS accreditation.

High Channel (2 462 MHz)

| Radiated Emissions | | | Ant. | Correction Factors | | | Total | Limit | |
|--------------------|----------------------|-------------|------|--------------------|---------|-----------|-----------------------|----------------------|-------------|
| Frequency (MHz) | Reading (dB μ V) | Detect Mode | Pol. | AF (dB/m) | CL (dB) | Duty (dB) | Actual (dB μ V/m) | Limit (dB μ V/m) | Margin (dB) |
| *2 483.50 | 32.79 | Peak | H | 28.24 | 7.27 | - | 68.30 | 74.00 | 5.70 |
| *2 483.50 | 14.61 | Average | H | 28.24 | 7.27 | - | 50.12 | 54.00 | 3.88 |
| *2 483.64 | 32.41 | Peak | H | 28.24 | 7.27 | - | 67.92 | 74.00 | 6.08 |
| *2 483.80 | 15.31 | Average | H | 28.24 | 7.27 | - | 50.82 | 54.00 | 3.18 |
| *2 500.00 | 22.05 | Peak | H | 28.26 | 7.19 | - | 57.50 | 74.00 | 16.50 |
| *2 500.00 | 11.49 | Average | H | 28.26 | 7.19 | - | 46.94 | 54.00 | 7.06 |

| Radiated Emissions | | | Ant. | Correction Factors | | | Total | Limit | |
|--------------------|----------------------|-------------|------|--------------------|-------------|-----------|-----------------------|----------------------|-------------|
| Frequency (MHz) | Reading (dB μ V) | Detect Mode | Pol. | AF (dB/m) | AMP+CL (dB) | Duty (dB) | Actual (dB μ V/m) | Limit (dB μ V/m) | Margin (dB) |
| *4 920.10 | 41.30 | Peak | H | 32.97 | -27.62 | - | 46.65 | 74.00 | 27.35 |
| *4 926.00 | 30.89 | Average | H | 32.98 | -27.59 | - | 36.28 | 54.00 | 17.72 |
| Above 5 000.00 | Not detected | - | - | - | - | - | - | - | - |

The results shown in this test report refer only to the sample(s) tested unless otherwise stated. This test report cannot be reproduced, except in full, without prior written permission of the Company. This test report does not assure KOLAS accreditation.

OFDM: 802.11n_HT20 (MCS0)

Low Channel (2 412 MHz)

| Radiated Emissions | | | Ant. | Correction Factors | | | Total | Limit | |
|--------------------|----------------------|-------------|------|--------------------|---------|-----------|-----------------------|----------------------|-------------|
| Frequency (MHz) | Reading (dB μ V) | Detect Mode | Pol. | AF (dB/m) | CL (dB) | Duty (dB) | Actual (dB μ V/m) | Limit (dB μ V/m) | Margin (dB) |
| *2 310.00 | 18.54 | Peak | H | 28.07 | 6.92 | - | 53.53 | 74.00 | 20.47 |
| *2 310.00 | 7.62 | Average | H | 28.07 | 6.92 | - | 42.61 | 54.00 | 11.39 |
| *2 389.65 | 29.02 | Peak | H | 28.15 | 6.97 | - | 64.14 | 74.00 | 9.86 |
| *2 389.87 | 14.05 | Average | H | 28.15 | 6.97 | - | 49.17 | 54.00 | 4.83 |
| *2 390.00 | 29.43 | Peak | H | 28.15 | 6.97 | - | 64.55 | 74.00 | 9.45 |
| *2 390.00 | 13.37 | Average | H | 28.15 | 6.97 | - | 48.49 | 54.00 | 5.51 |

| Radiated Emissions | | | Ant. | Correction Factors | | | Total | Limit | |
|--------------------|----------------------|-------------|------|--------------------|-------------|-----------|-----------------------|----------------------|-------------|
| Frequency (MHz) | Reading (dB μ V) | Detect Mode | Pol. | AF (dB/m) | AMP+CL (dB) | Duty (dB) | Actual (dB μ V/m) | Limit (dB μ V/m) | Margin (dB) |
| *4 826.20 | 43.79 | Peak | H | 32.71 | -28.16 | - | 48.34 | 74.00 | 25.66 |
| *4 824.20 | 33.45 | Average | H | 32.71 | -28.14 | - | 38.02 | 54.00 | 15.98 |
| Above 4 900.00 | Not detected | - | - | - | - | - | - | - | - |

Middle Channel (2 437 MHz)

| Radiated Emissions | | | Ant. | Correction Factors | | | Total | Limit | |
|--------------------|----------------------|-------------|------|--------------------|-------------|-----------|-----------------------|----------------------|-------------|
| Frequency (MHz) | Reading (dB μ V) | Detect Mode | Pol. | AF (dB/m) | AMP+CL (dB) | Duty (dB) | Actual (dB μ V/m) | Limit (dB μ V/m) | Margin (dB) |
| *4 879.20 | 42.80 | Peak | H | 32.86 | -27.99 | - | 47.67 | 74.00 | 26.33 |
| *4 873.70 | 31.88 | Average | H | 32.84 | -28.02 | - | 36.70 | 54.00 | 17.30 |
| Above 4 900.00 | Not detected | - | - | - | - | - | - | - | - |

The results shown in this test report refer only to the sample(s) tested unless otherwise stated. This test report cannot be reproduced, except in full, without prior written permission of the Company. This test report does not assure KOLAS accreditation.

High Channel (2 462 MHz)

| Radiated Emissions | | | Ant. | Correction Factors | | | Total | Limit | |
|--------------------|----------------------|-------------|------|--------------------|---------|-----------|-----------------------|----------------------|-------------|
| Frequency (MHz) | Reading (dB μ V) | Detect Mode | Pol. | AF (dB/m) | CL (dB) | Duty (dB) | Actual (dB μ V/m) | Limit (dB μ V/m) | Margin (dB) |
| *2 483.50 | 28.97 | Peak | H | 28.24 | 7.27 | - | 64.48 | 74.00 | 9.52 |
| *2 483.50 | 15.27 | Average | H | 28.24 | 7.27 | - | 50.78 | 54.00 | 3.22 |
| *2 483.60 | 33.12 | Peak | H | 28.24 | 7.27 | - | 68.63 | 74.00 | 5.37 |
| *2 483.76 | 15.37 | Average | H | 28.24 | 7.27 | - | 50.88 | 54.00 | 3.12 |
| *2 500.00 | 22.14 | Peak | H | 28.26 | 7.19 | - | 57.59 | 74.00 | 16.41 |
| *2 500.00 | 10.92 | Average | H | 28.26 | 7.19 | - | 46.37 | 54.00 | 7.63 |

| Radiated Emissions | | | Ant. | Correction Factors | | | Total | Limit | |
|--------------------|----------------------|-------------|------|--------------------|-------------|-----------|-----------------------|----------------------|-------------|
| Frequency (MHz) | Reading (dB μ V) | Detect Mode | Pol. | AF (dB/m) | AMP+CL (dB) | Duty (dB) | Actual (dB μ V/m) | Limit (dB μ V/m) | Margin (dB) |
| *4 926.60 | 40.26 | Peak | H | 32.98 | -27.60 | - | 45.64 | 74.00 | 28.36 |
| *4 925.20 | 29.73 | Average | H | 32.98 | -27.57 | - | 35.14 | 54.00 | 18.86 |
| Above 5 000.00 | Not detected | - | - | - | - | - | - | - | - |

The results shown in this test report refer only to the sample(s) tested unless otherwise stated. This test report cannot be reproduced, except in full, without prior written permission of the Company. This test report does not assure KOLAS accreditation.

OFDM: 802.11n_HT40 (MCS0)

Low Channel (2 422 MHz)

| Radiated Emissions | | | Ant. | Correction Factors | | | Total | Limit | |
|--------------------|----------------------|-------------|------|--------------------|---------|-----------|-----------------------|----------------------|-------------|
| Frequency (MHz) | Reading (dB μ V) | Detect Mode | Pol. | AF (dB/m) | CL (dB) | Duty (dB) | Actual (dB μ V/m) | Limit (dB μ V/m) | Margin (dB) |
| *2 310.00 | 18.07 | Peak | H | 28.07 | 6.92 | - | 53.06 | 74.00 | 20.94 |
| *2 310.00 | 7.61 | Average | H | 28.07 | 6.92 | - | 42.60 | 54.00 | 11.40 |
| *2 389.54 | 32.50 | Peak | H | 28.15 | 6.97 | - | 67.62 | 74.00 | 6.38 |
| *2 389.76 | 15.35 | Average | H | 28.15 | 6.97 | - | 50.47 | 54.00 | 3.53 |
| *2 390.00 | 30.62 | Peak | H | 28.15 | 6.97 | - | 65.74 | 74.00 | 8.26 |
| *2 390.00 | 15.38 | Average | H | 28.15 | 6.97 | - | 50.50 | 54.00 | 3.50 |

| Radiated Emissions | | | Ant. | Correction Factors | | | Total | Limit | |
|--------------------|----------------------|-------------|------|--------------------|-------------|-----------|-----------------------|----------------------|-------------|
| Frequency (MHz) | Reading (dB μ V) | Detect Mode | Pol. | AF (dB/m) | AMP+CL (dB) | Duty (dB) | Actual (dB μ V/m) | Limit (dB μ V/m) | Margin (dB) |
| *4 847.60 | 41.04 | Peak | H | 32.77 | -28.07 | - | 45.74 | 74.00 | 28.26 |
| *4 846.90 | 31.06 | Average | H | 32.77 | -28.07 | - | 35.76 | 54.00 | 18.24 |
| Above 4 900.00 | Not detected | - | - | - | - | - | - | - | - |

Middle Channel (2 437 MHz)

| Radiated Emissions | | | Ant. | Correction Factors | | | Total | Limit | |
|--------------------|----------------------|-------------|------|--------------------|-------------|-----------|-----------------------|----------------------|-------------|
| Frequency (MHz) | Reading (dB μ V) | Detect Mode | Pol. | AF (dB/m) | AMP+CL (dB) | Duty (dB) | Actual (dB μ V/m) | Limit (dB μ V/m) | Margin (dB) |
| *4 871.20 | 40.19 | Peak | H | 32.83 | -28.02 | - | 45.00 | 74.00 | 29.00 |
| *4 870.70 | 30.18 | Average | H | 32.83 | -28.02 | - | 34.99 | 54.00 | 19.01 |
| Above 4 900.00 | Not detected | - | - | - | - | - | - | - | - |

The results shown in this test report refer only to the sample(s) tested unless otherwise stated. This test report cannot be reproduced, except in full, without prior written permission of the Company. This test report does not assure KOLAS accreditation.

High Channel (2 452 MHz)

| Radiated Emissions | | | Ant. | Correction Factors | | | Total | Limit | |
|--------------------|----------------------|-------------|------|--------------------|---------|-----------|-----------------------|----------------------|-------------|
| Frequency (MHz) | Reading (dB μ V) | Detect Mode | Pol. | AF (dB/m) | CL (dB) | Duty (dB) | Actual (dB μ V/m) | Limit (dB μ V/m) | Margin (dB) |
| *2 483.50 | 26.97 | Peak | H | 28.24 | 7.27 | - | 62.48 | 74.00 | 11.52 |
| *2 483.50 | 14.28 | Average | H | 28.24 | 7.27 | - | 49.79 | 54.00 | 4.21 |
| *2 485.32 | 30.72 | Peak | H | 28.25 | 7.26 | - | 66.23 | 74.00 | 7.77 |
| *2 484.04 | 14.38 | Average | H | 28.24 | 7.27 | - | 49.89 | 54.00 | 4.11 |
| *2 500.00 | 21.25 | Peak | H | 28.26 | 7.19 | - | 56.70 | 74.00 | 17.30 |
| *2 500.00 | 10.47 | Average | H | 28.26 | 7.19 | - | 45.92 | 54.00 | 8.08 |

| Radiated Emissions | | | Ant. | Correction Factors | | | Total | Limit | |
|--------------------|----------------------|-------------|------|--------------------|-------------|-----------|-----------------------|----------------------|-------------|
| Frequency (MHz) | Reading (dB μ V) | Detect Mode | Pol. | AF (dB/m) | AMP+CL (dB) | Duty (dB) | Actual (dB μ V/m) | Limit (dB μ V/m) | Margin (dB) |
| *4 882.40 | 39.75 | Peak | H | 32.86 | -27.97 | - | 44.64 | 74.00 | 29.36 |
| *4 900.50 | 29.40 | Average | H | 32.91 | -27.84 | - | 34.47 | 54.00 | 19.53 |
| Above 5 000.00 | Not detected | - | - | - | - | - | - | - | - |

Remarks;

1. "*" means the restricted band.
2. Measuring frequencies from 1 GHz to the 10th harmonic of highest fundamental frequency.
3. Radiated emissions measured in frequency above 1 000 MHz were made with an instrument using peak/average detector mode.
4. Actual = Reading + AF + AMP + CL or Reading + AF + CL.
5. According to § 15.31(o), emission levels are not reported much lower than the limits by over 20 dB.

The results shown in this test report refer only to the sample(s) tested unless otherwise stated. This test report cannot be reproduced, except in full, without prior written permission of the Company. This test report does not assure KOLAS accreditation.

2.4.3. Plot of Transmitter Radiated Spurious Emissions

DSSS: 802.11b (1 Mbps)

Low channel Band edge (Peak)

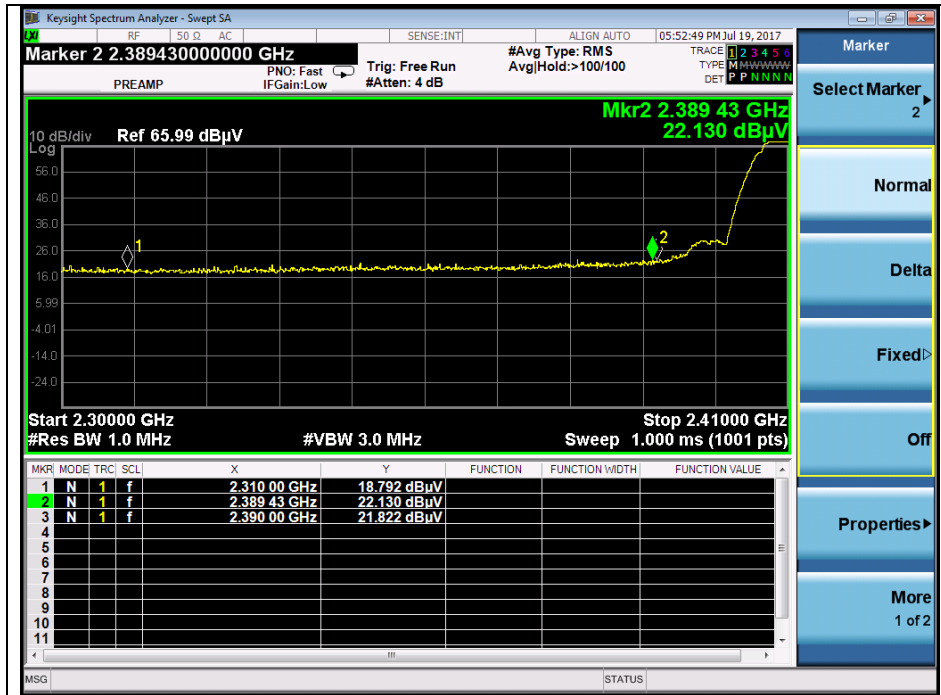

Low channel Band edge (Average)



The results shown in this test report refer only to the sample(s) tested unless otherwise stated. This test report cannot be reproduced, except in full, without prior written permission of the Company. This test report does not assure KOLAS accreditation.

High channel Band edge (Peak)

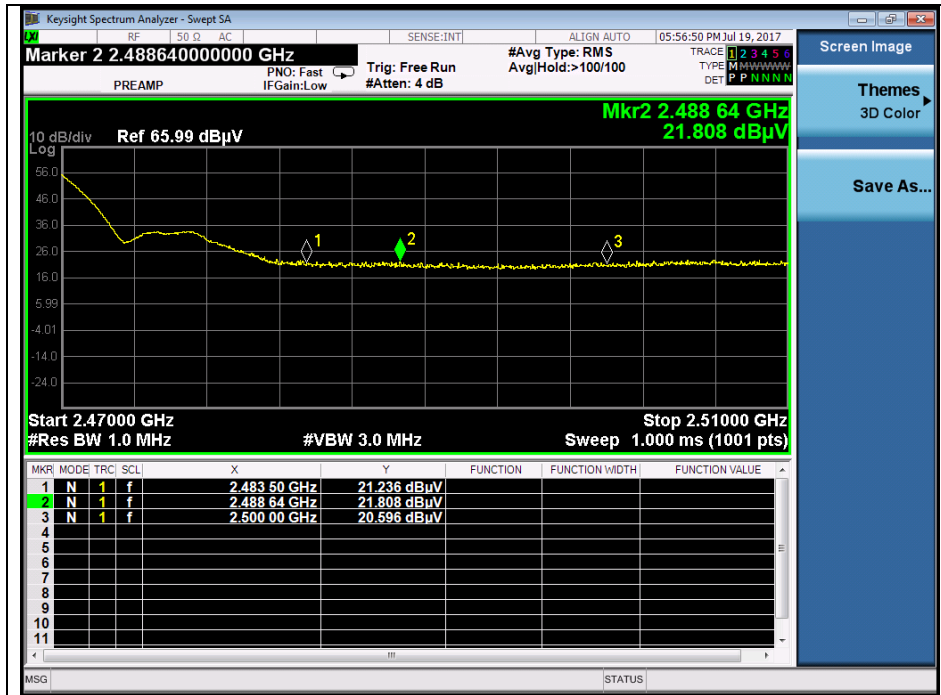

High channel Band edge (Average)



The results shown in this test report refer only to the sample(s) tested unless otherwise stated. This test report cannot be reproduced, except in full, without prior written permission of the Company. This test report does not assure KOLAS accreditation.

OFDM : 802.11g (6 Mbps)

Low channel Band edge (Peak)

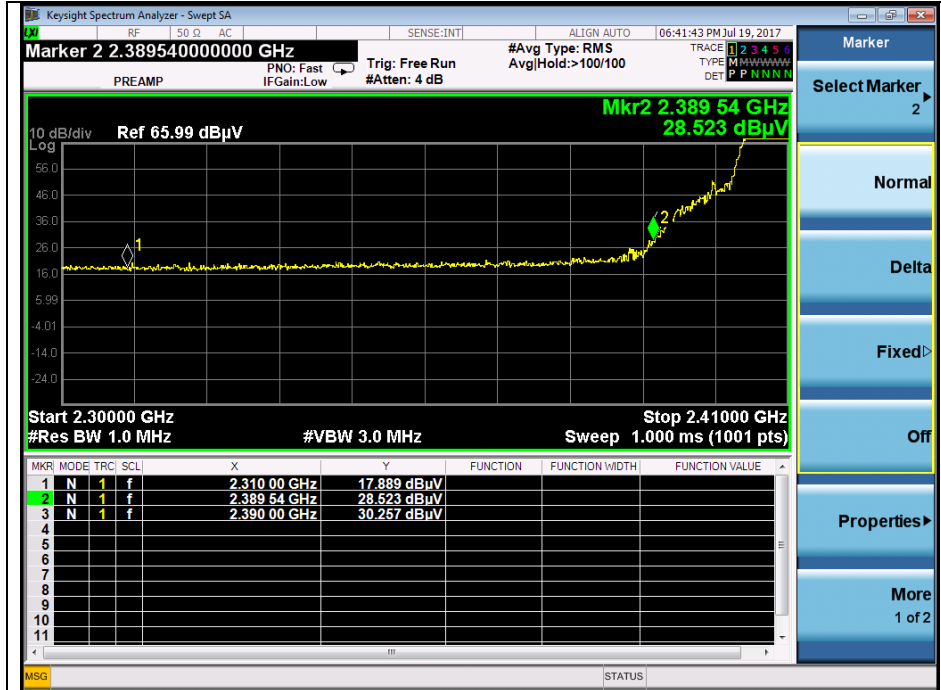

Low channel Band edge (Average)



The results shown in this test report refer only to the sample(s) tested unless otherwise stated. This test report cannot be reproduced, except in full, without prior written permission of the Company. This test report does not assure KOLAS accreditation.

High channel Band edge (Peak)

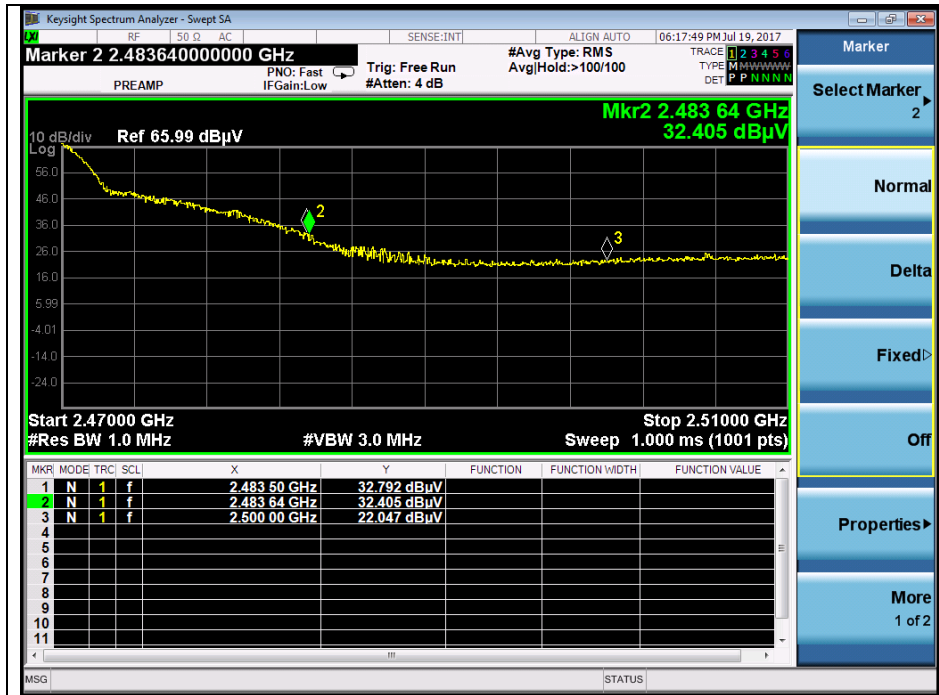

High channel Band edge (Average)



The results shown in this test report refer only to the sample(s) tested unless otherwise stated. This test report cannot be reproduced, except in full, without prior written permission of the Company. This test report does not assure KOLAS accreditation.

OFDM: 802.11n_HT20 (MCS0)

Low channel Band edge (Peak)



Low channel Band edge (Average)



The results shown in this test report refer only to the sample(s) tested unless otherwise stated. This test report cannot be reproduced, except in full, without prior written permission of the Company. This test report does not assure KOLAS accreditation.

High channel Band edge (Peak)



High channel Band edge (Average)



The results shown in this test report refer only to the sample(s) tested unless otherwise stated. This test report cannot be reproduced, except in full, without prior written permission of the Company. This test report does not assure KOLAS accreditation.

OFDM: 802.11n_HT40 (MCS0)

Low channel Band edge (Peak)



Low channel Band edge (Average)



The results shown in this test report refer only to the sample(s) tested unless otherwise stated. This test report cannot be reproduced, except in full, without prior written permission of the Company. This test report does not assure KOLAS accreditation.

High channel Band edge (Peak)

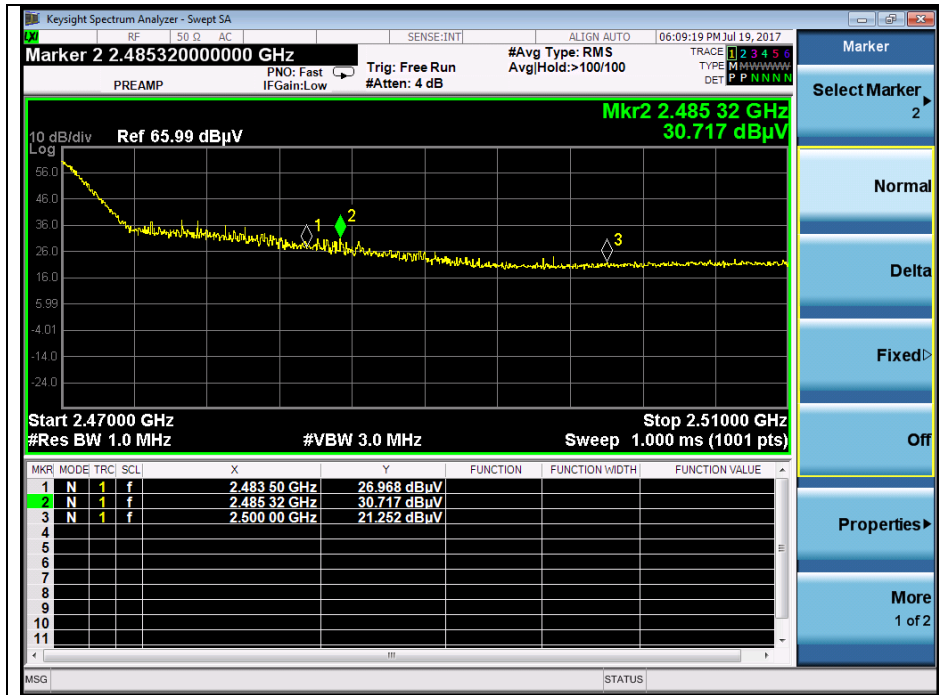

High channel Band edge (Average)



The results shown in this test report refer only to the sample(s) tested unless otherwise stated. This test report cannot be reproduced, except in full, without prior written permission of the Company. This test report does not assure KOLAS accreditation.

DSSS : 802.11b (1 Mbps)

Low channel 2nd harmonic (Peak)



Low channel 2nd harmonic (Average)

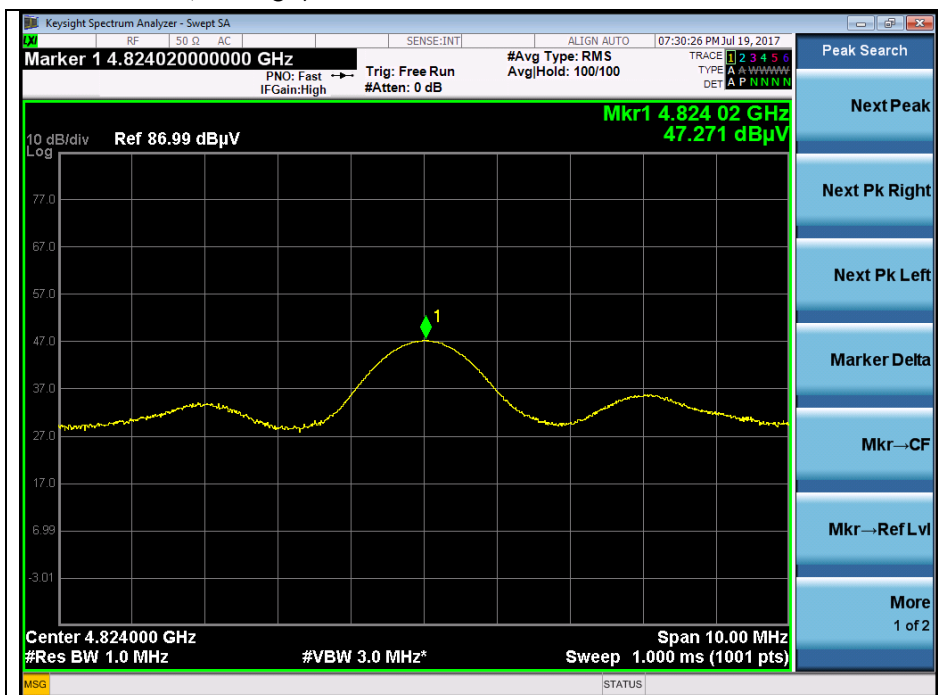

The results shown in this test report refer only to the sample(s) tested unless otherwise stated. This test report cannot be reproduced, except in full, without prior written permission of the Company. This test report does not assure KOLAS accreditation.

Middle channel 2nd harmonic (Peak)



Middle channel 2nd harmonic (Average)

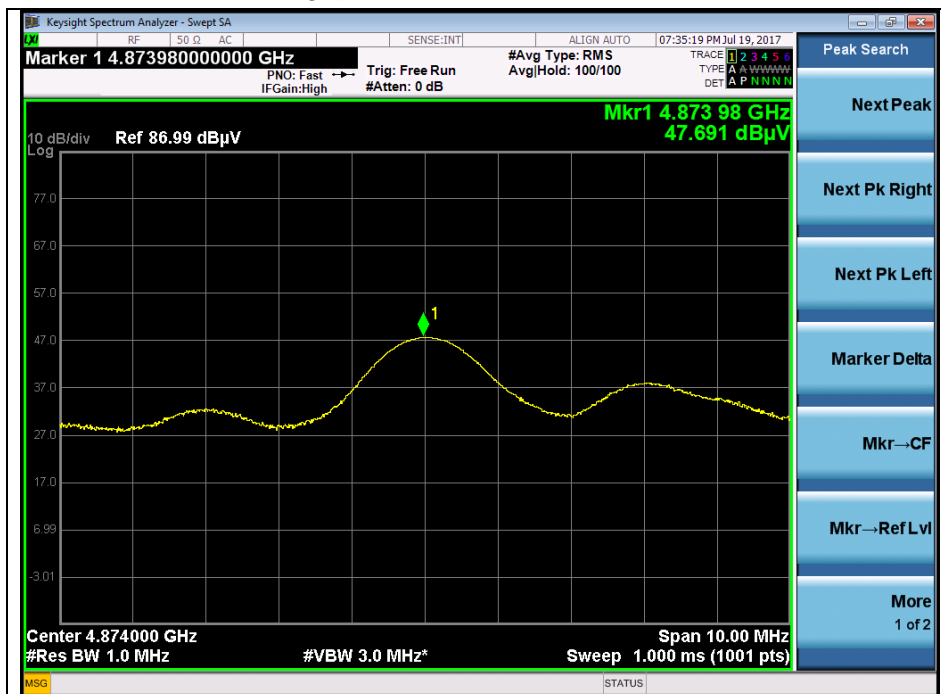

The results shown in this test report refer only to the sample(s) tested unless otherwise stated. This test report cannot be reproduced, except in full, without prior written permission of the Company. This test report does not assure KOLAS accreditation.

High channel 2nd harmonic (Peak)

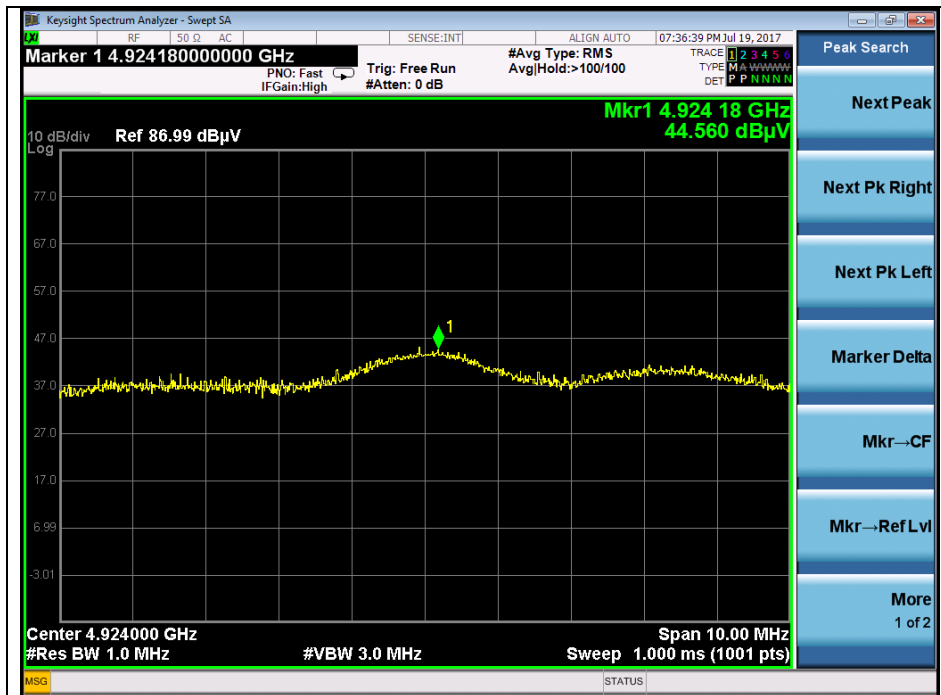

High channel 2nd harmonic (Average)

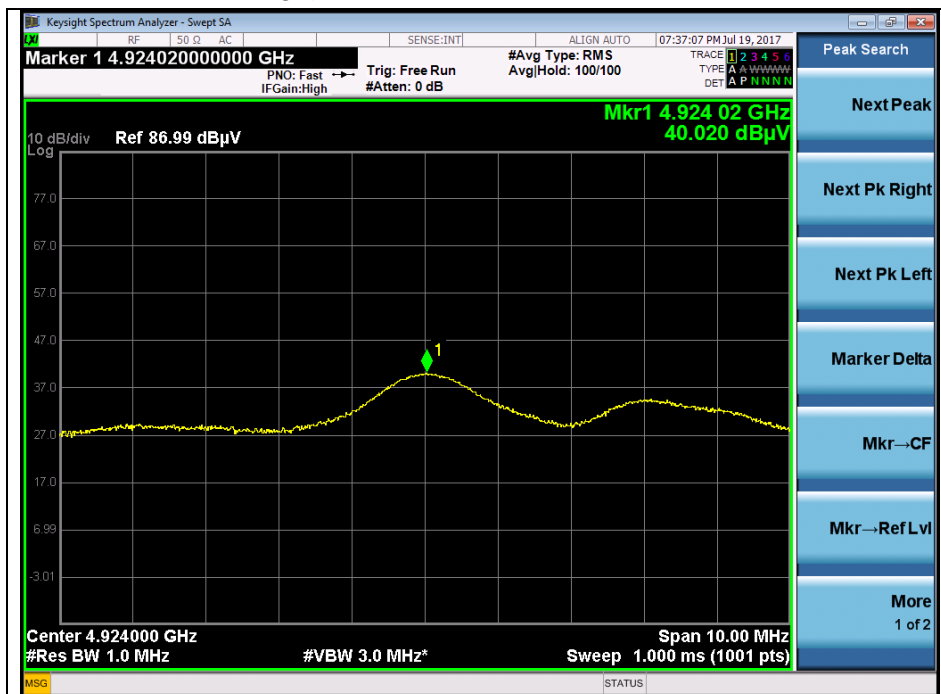

The results shown in this test report refer only to the sample(s) tested unless otherwise stated. This test report cannot be reproduced, except in full, without prior written permission of the Company. This test report does not assure KOLAS accreditation.

OFDM : 802.11g (6 Mbps)

Low channel 2nd harmonic (Peak)

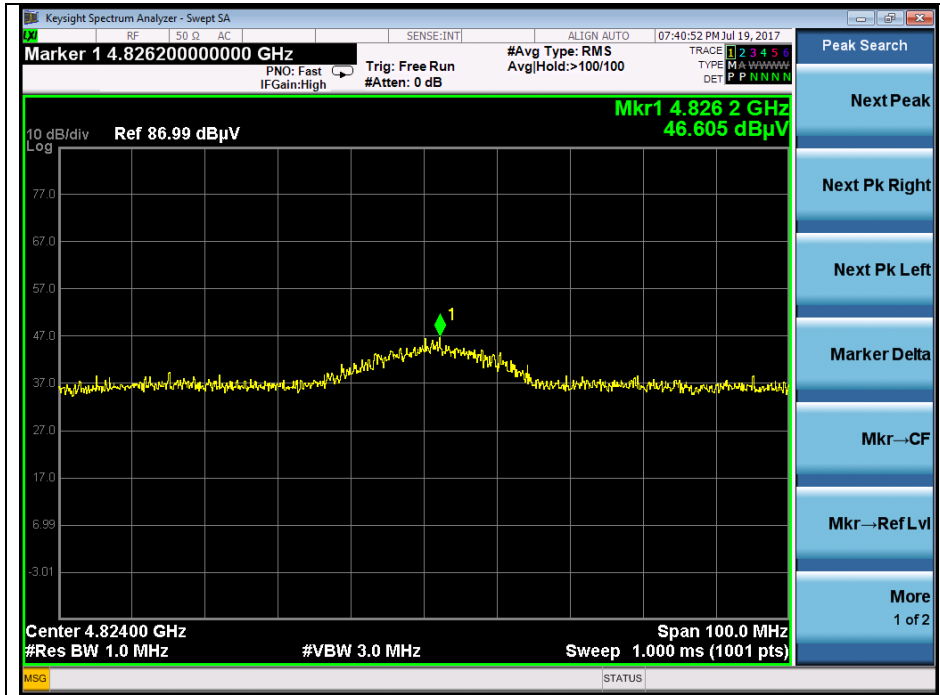

Low channel 2nd harmonic (Average)

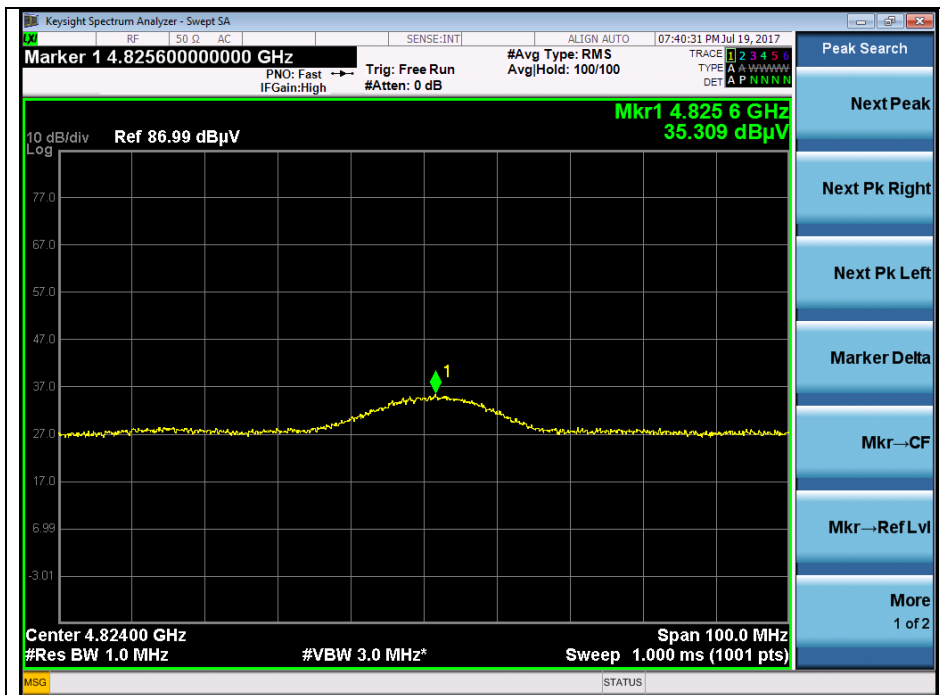

The results shown in this test report refer only to the sample(s) tested unless otherwise stated. This test report cannot be reproduced, except in full, without prior written permission of the Company. This test report does not assure KOLAS accreditation.

Middle channel 2nd harmonic (Peak)

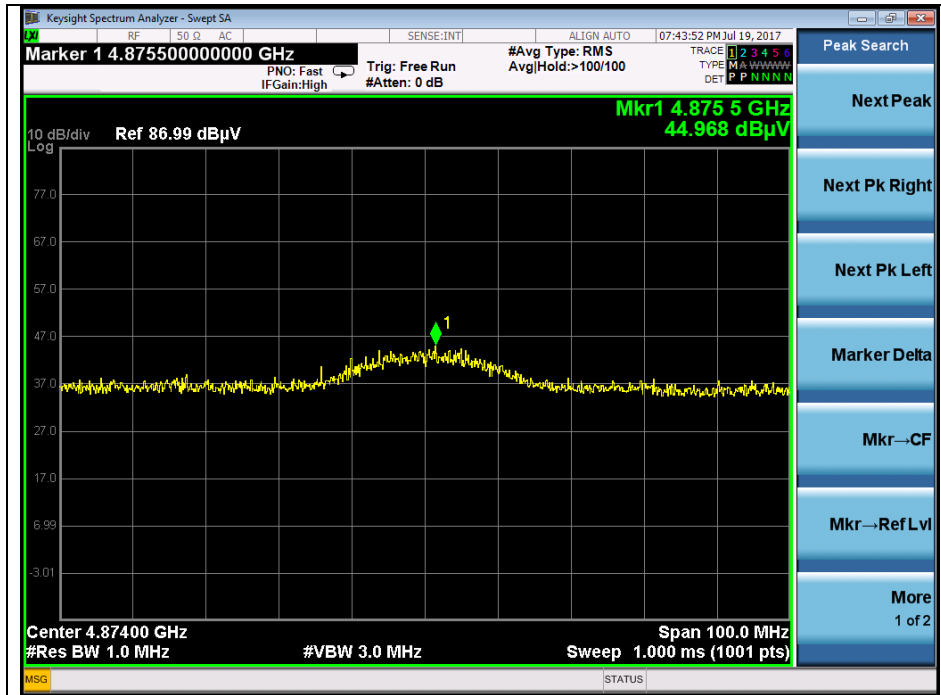

Middle channel 2nd harmonic (Average)

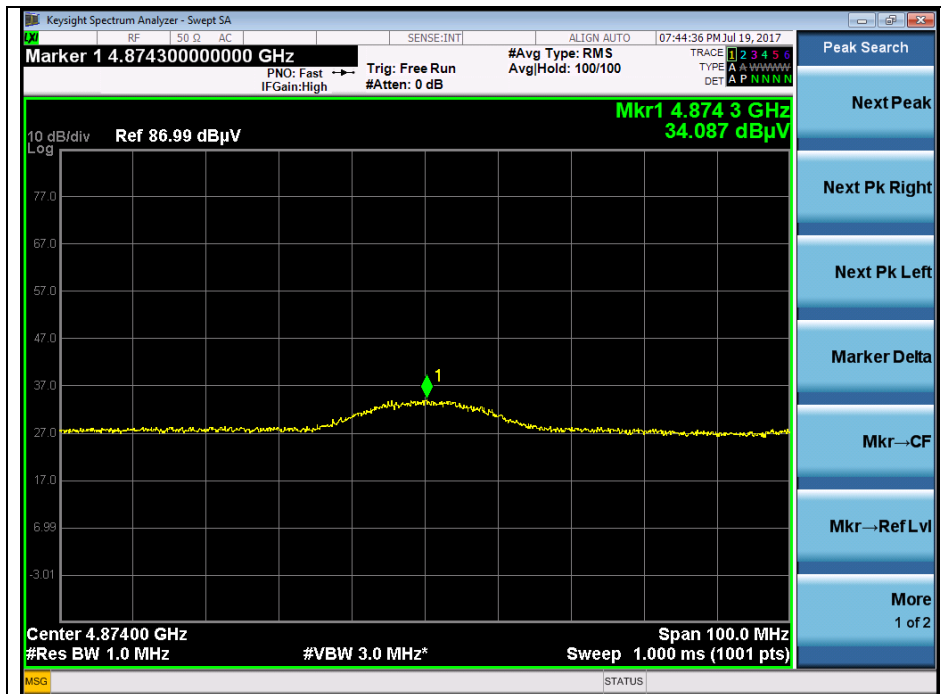

The results shown in this test report refer only to the sample(s) tested unless otherwise stated. This test report cannot be reproduced, except in full, without prior written permission of the Company. This test report does not assure KOLAS accreditation.

High channel 2nd harmonic (Peak)

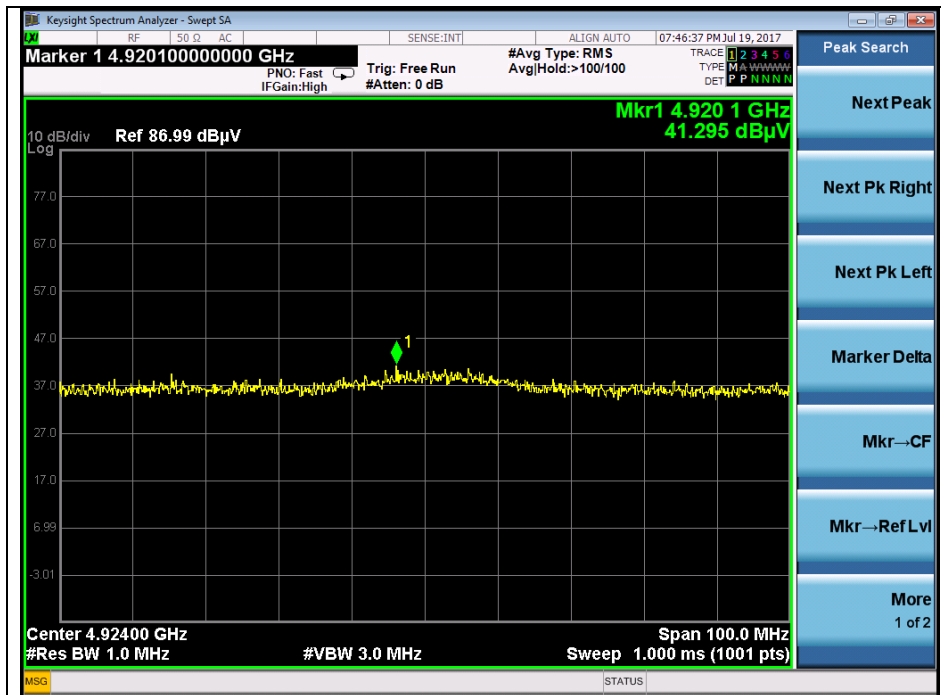

High channel 2nd harmonic (Average)

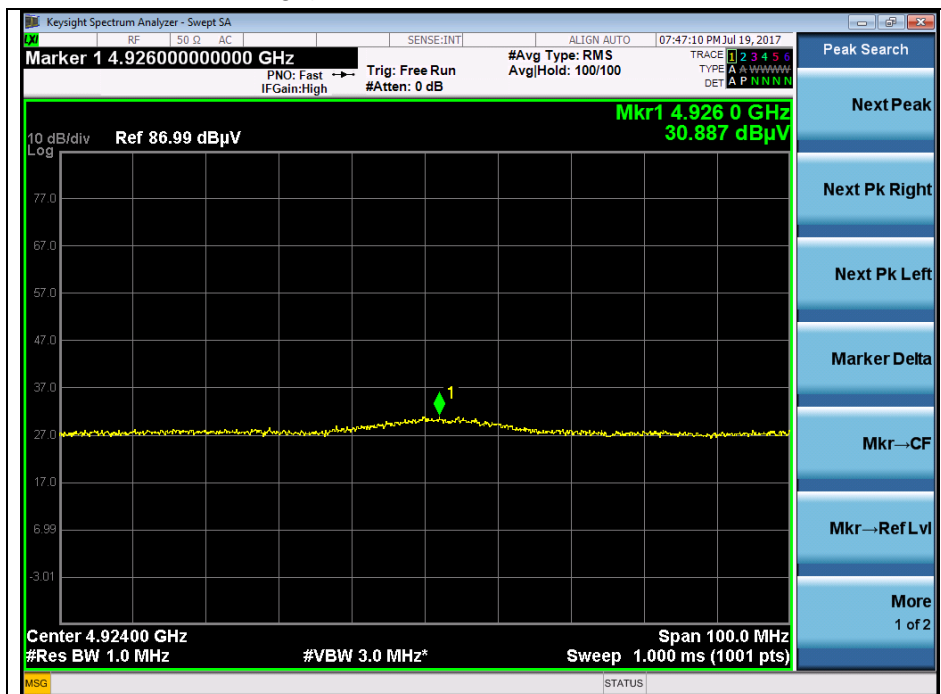

The results shown in this test report refer only to the sample(s) tested unless otherwise stated. This test report cannot be reproduced, except in full, without prior written permission of the Company. This test report does not assure KOLAS accreditation.

OFDM : 802.11n_HT20 (MCS0)

Low channel 2nd harmonic (Peak)

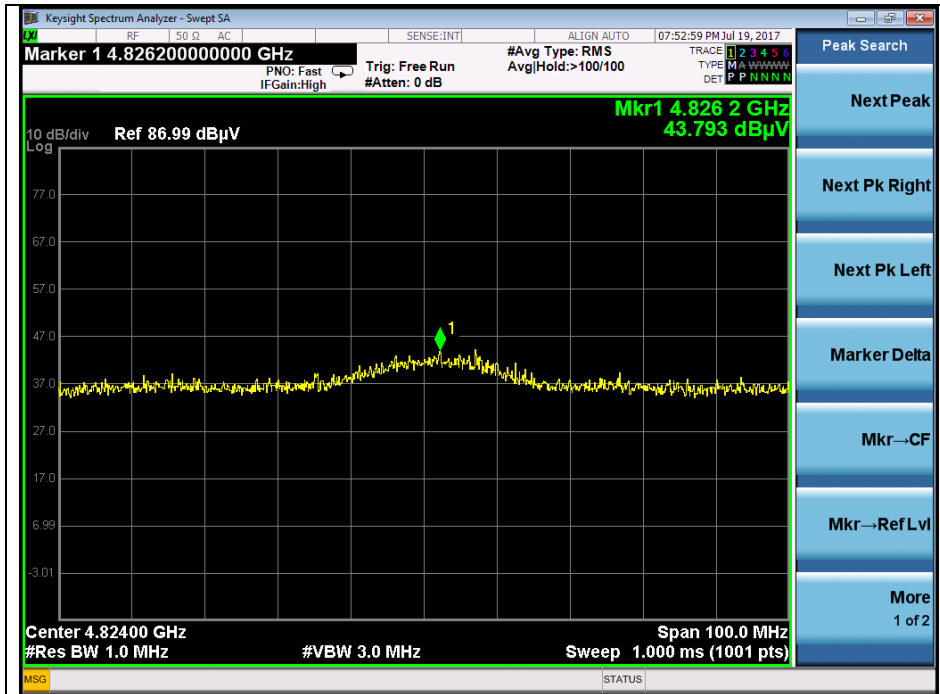

Low channel 2nd harmonic (Average)



The results shown in this test report refer only to the sample(s) tested unless otherwise stated. This test report cannot be reproduced, except in full, without prior written permission of the Company. This test report does not assure KOLAS accreditation.

Middle channel 2nd harmonic (Peak)

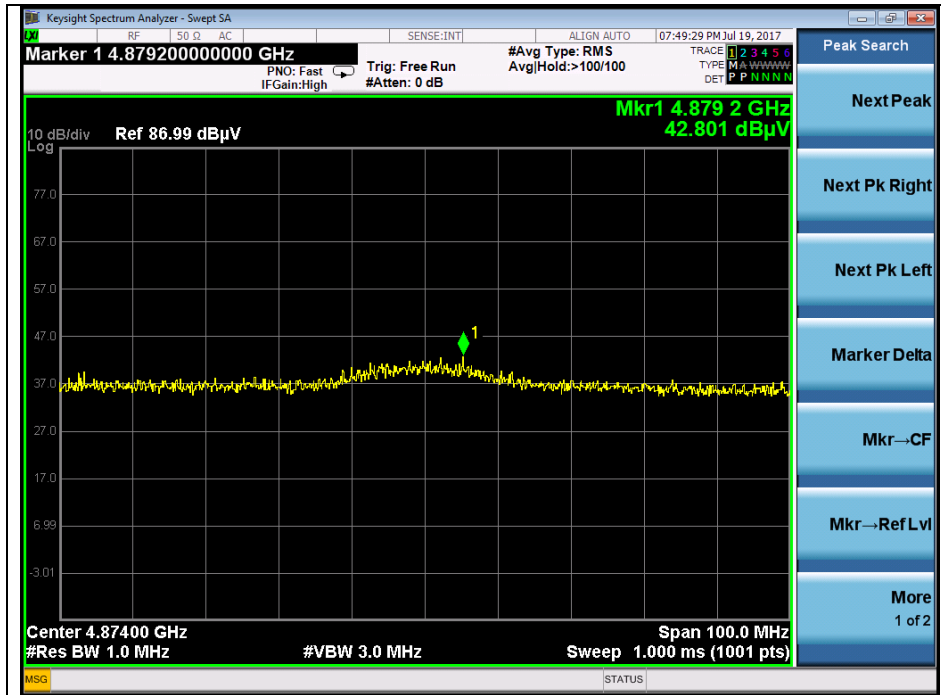

Middle channel 2nd harmonic (Average)

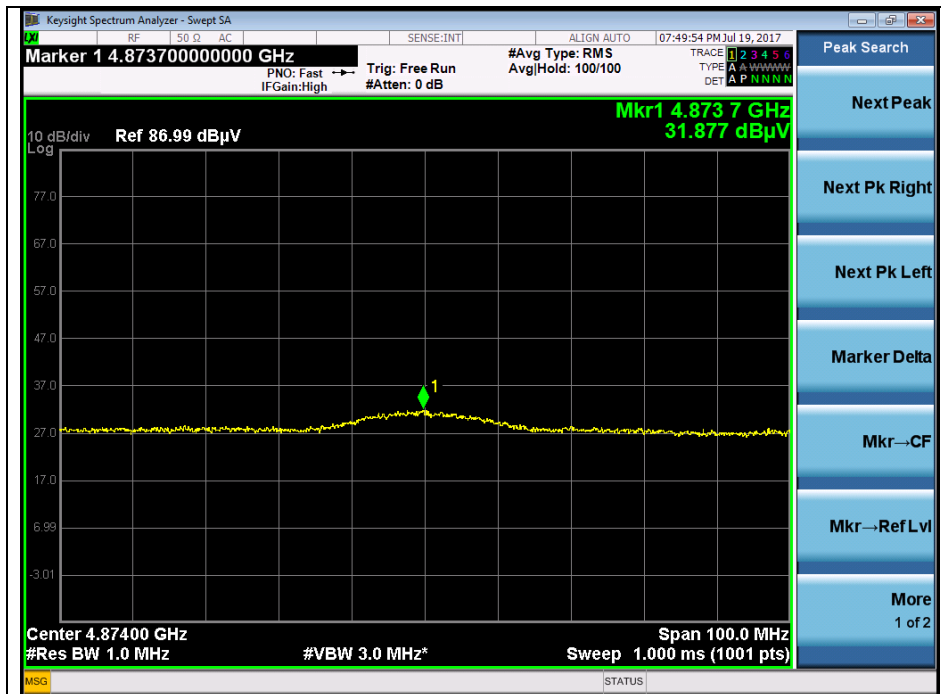

The results shown in this test report refer only to the sample(s) tested unless otherwise stated. This test report cannot be reproduced, except in full, without prior written permission of the Company. This test report does not assure KOLAS accreditation.

High channel 2nd harmonic (Peak)

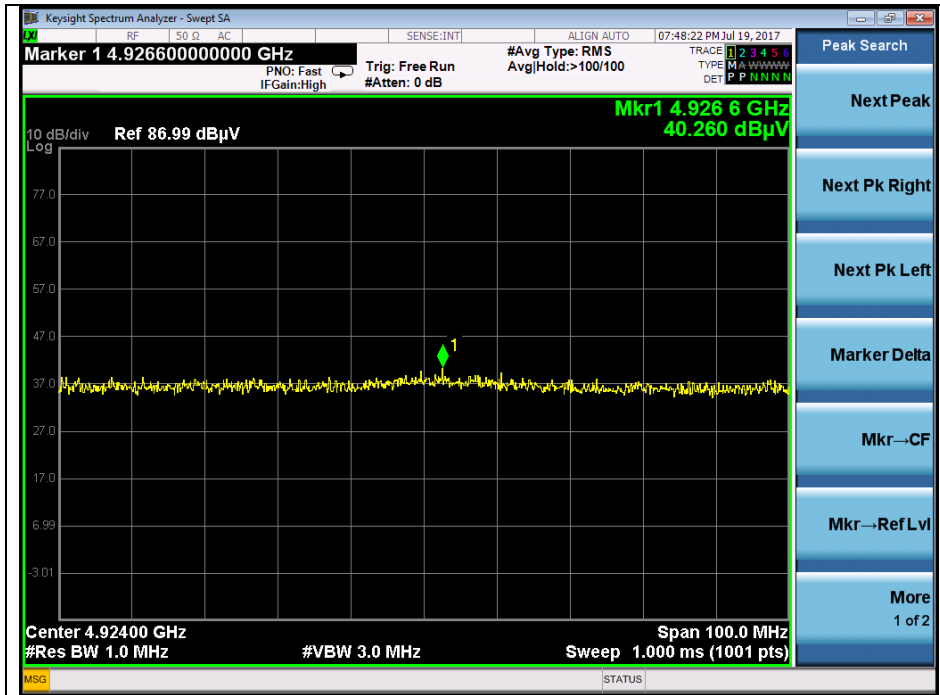

High channel 2nd harmonic (Average)

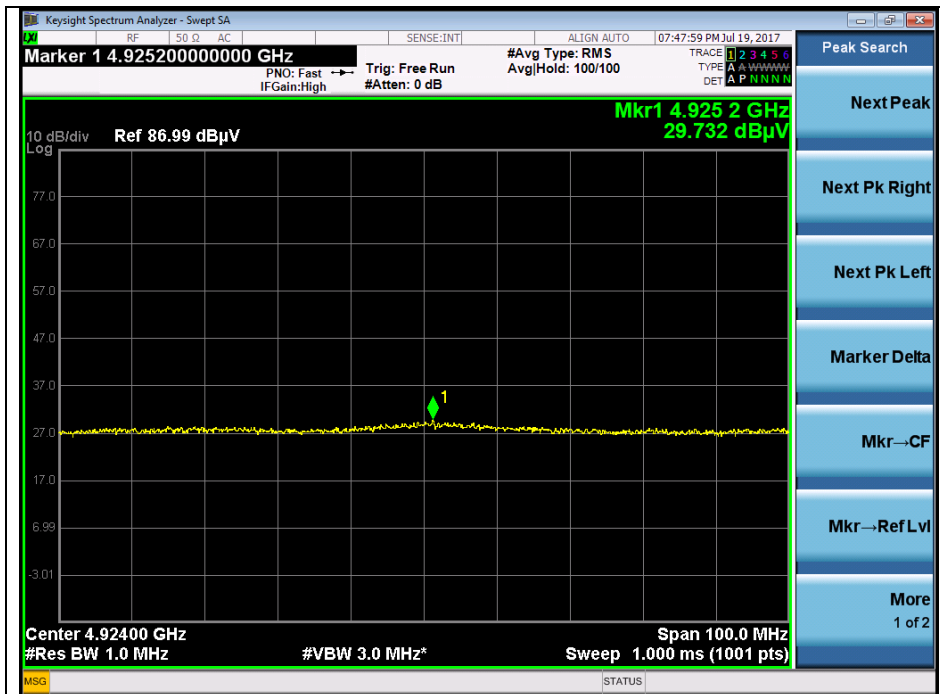

The results shown in this test report refer only to the sample(s) tested unless otherwise stated. This test report cannot be reproduced, except in full, without prior written permission of the Company. This test report does not assure KOLAS accreditation.

OFDM : 802.11n_HT40 (MCS0)

Low channel 2nd harmonic (Peak)

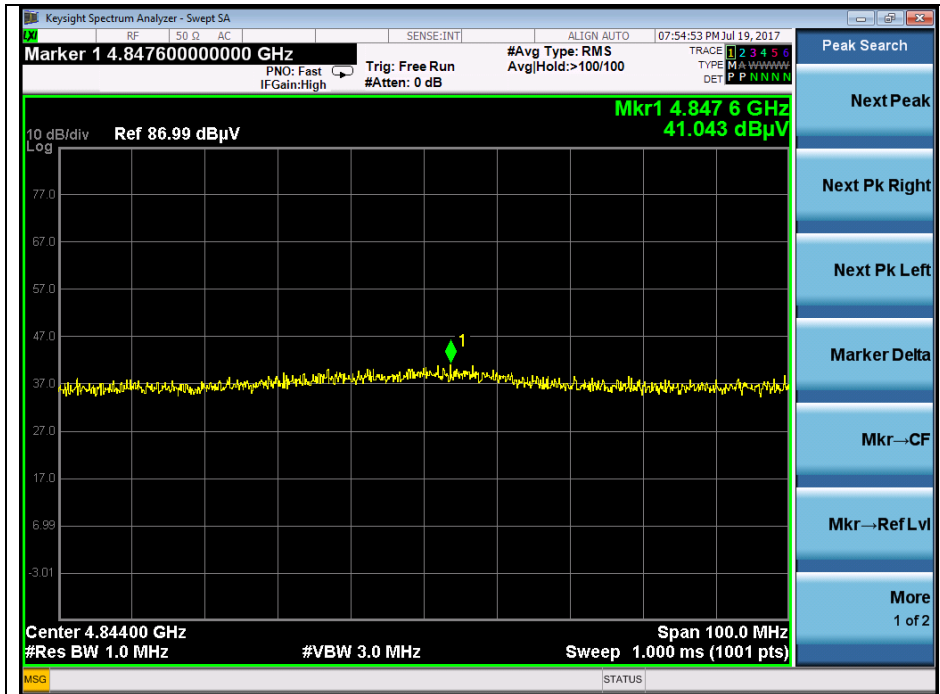

Low channel 2nd harmonic (Average)

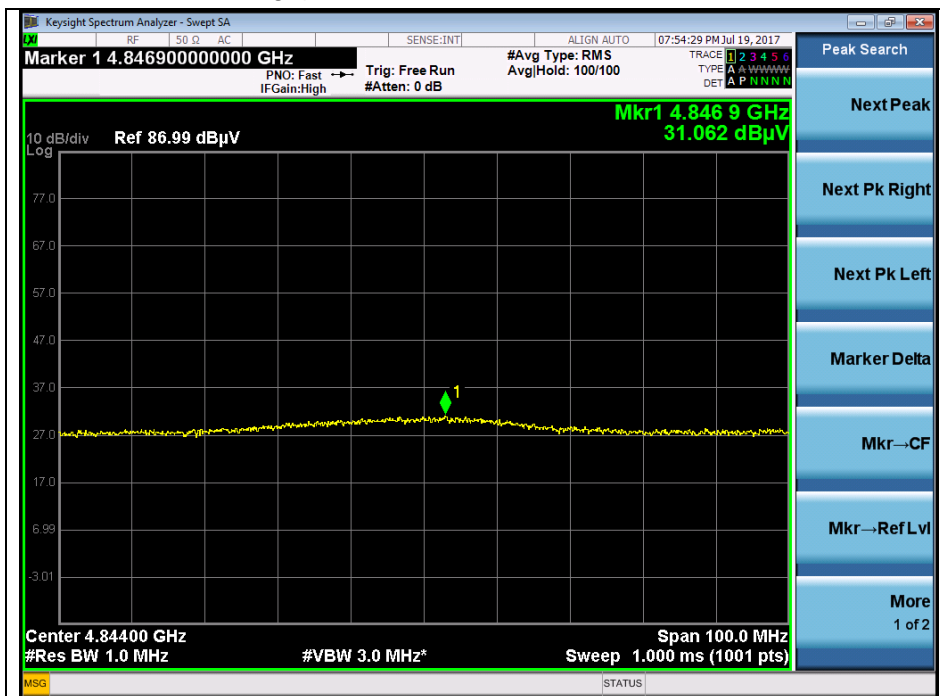

The results shown in this test report refer only to the sample(s) tested unless otherwise stated. This test report cannot be reproduced, except in full, without prior written permission of the Company. This test report does not assure KOLAS accreditation.

Middle channel 2nd harmonic (Peak)

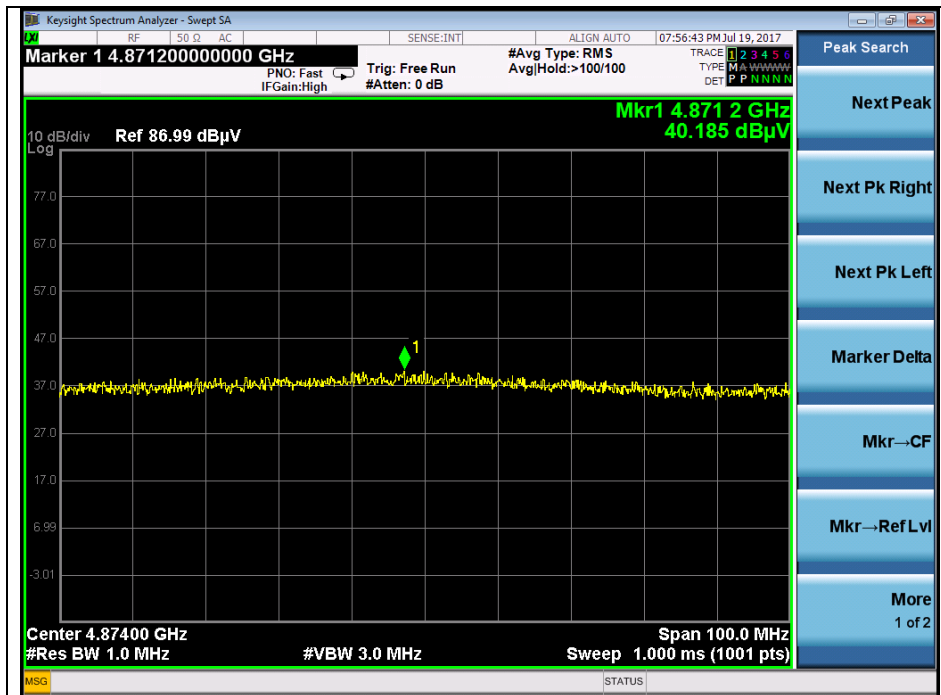

Middle channel 2nd harmonic (Average)

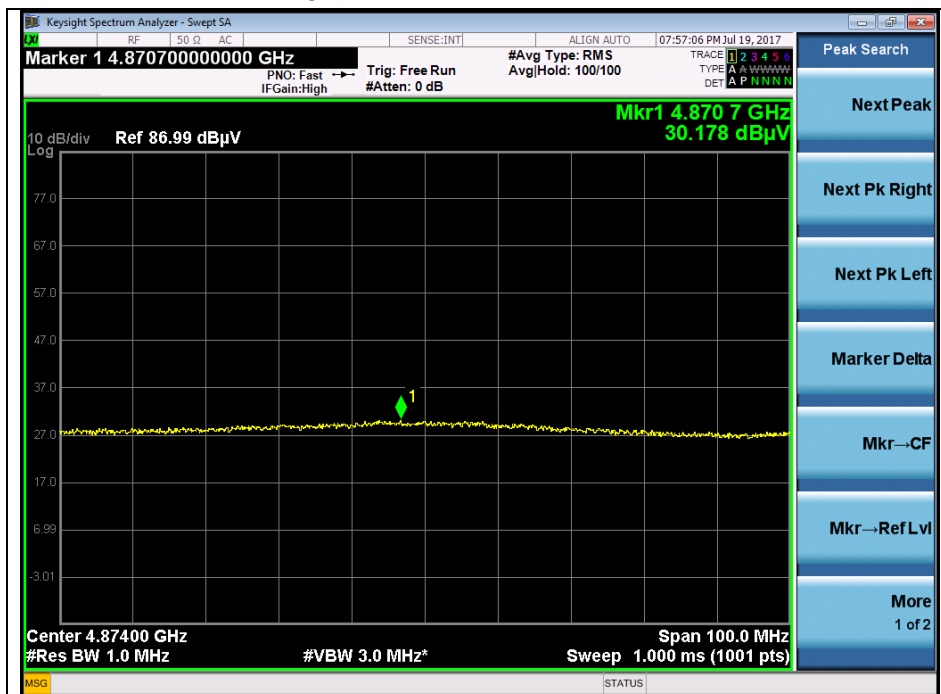

The results shown in this test report refer only to the sample(s) tested unless otherwise stated. This test report cannot be reproduced, except in full, without prior written permission of the Company. This test report does not assure KOLAS accreditation.

High channel 2nd harmonic (Peak)

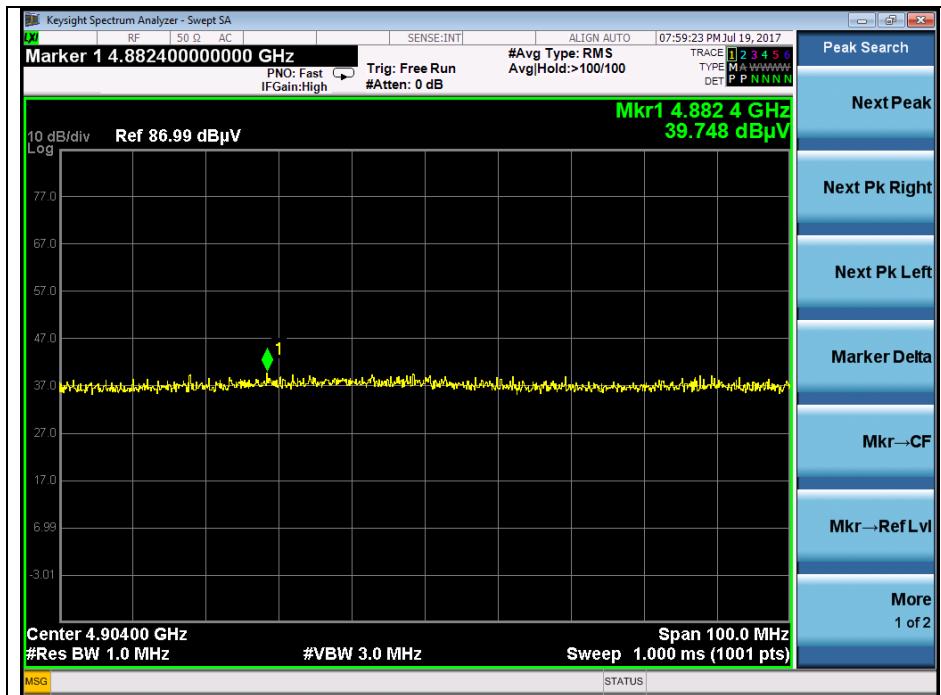

High channel 2nd harmonic (Average)

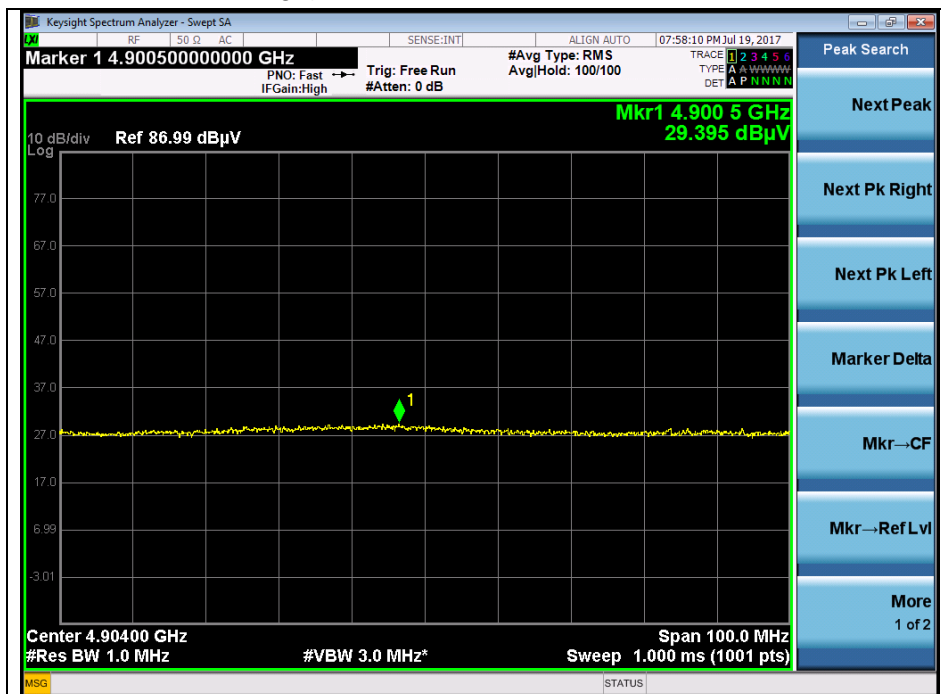

The results shown in this test report refer only to the sample(s) tested unless otherwise stated. This test report cannot be reproduced, except in full, without prior written permission of the Company. This test report does not assure KOLAS accreditation.

2.4.4. Plot of Conducted Spurious Emissions

DSSS: 802.11b (1 Mbps)

Low Channel

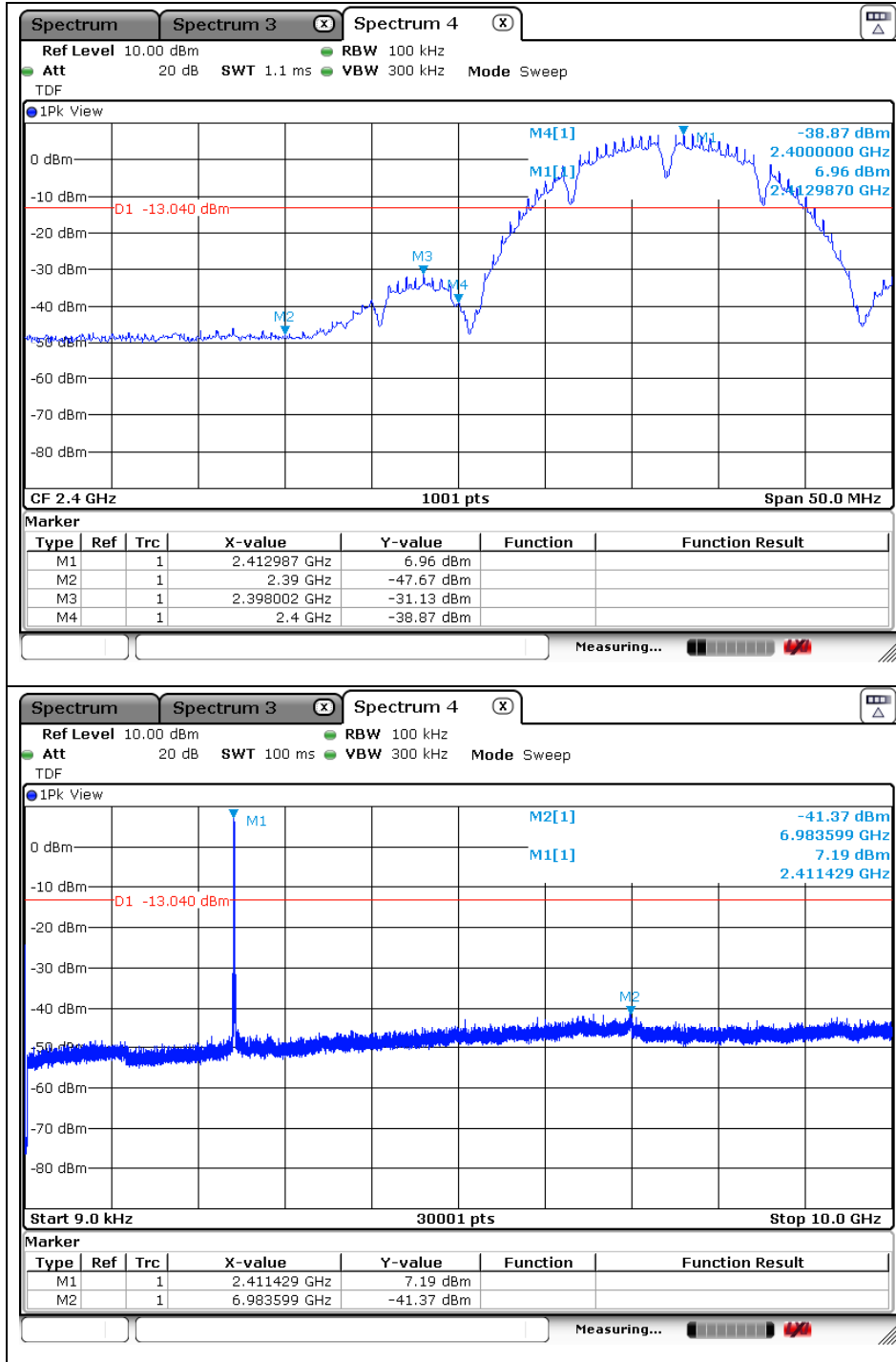

The results shown in this test report refer only to the sample(s) tested unless otherwise stated. This test report cannot be reproduced, except in full, without prior written permission of the Company. This test report does not assure KOLAS accreditation.

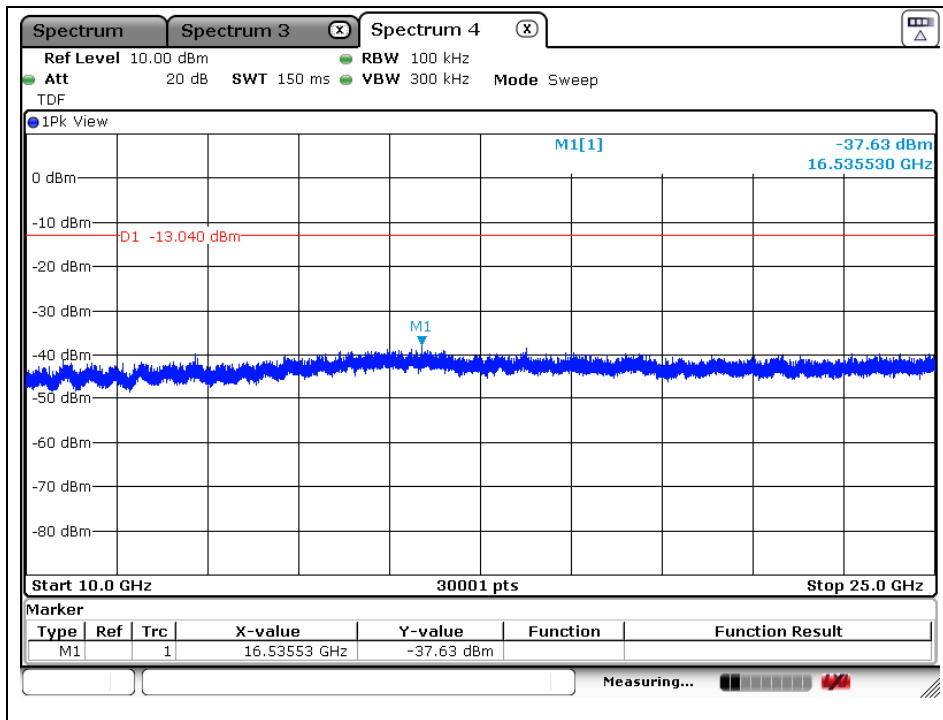

The results shown in this test report refer only to the sample(s) tested unless otherwise stated. This test report cannot be reproduced, except in full, without prior written permission of the Company. This test report does not assure KOLAS accreditation.

Middle Channel

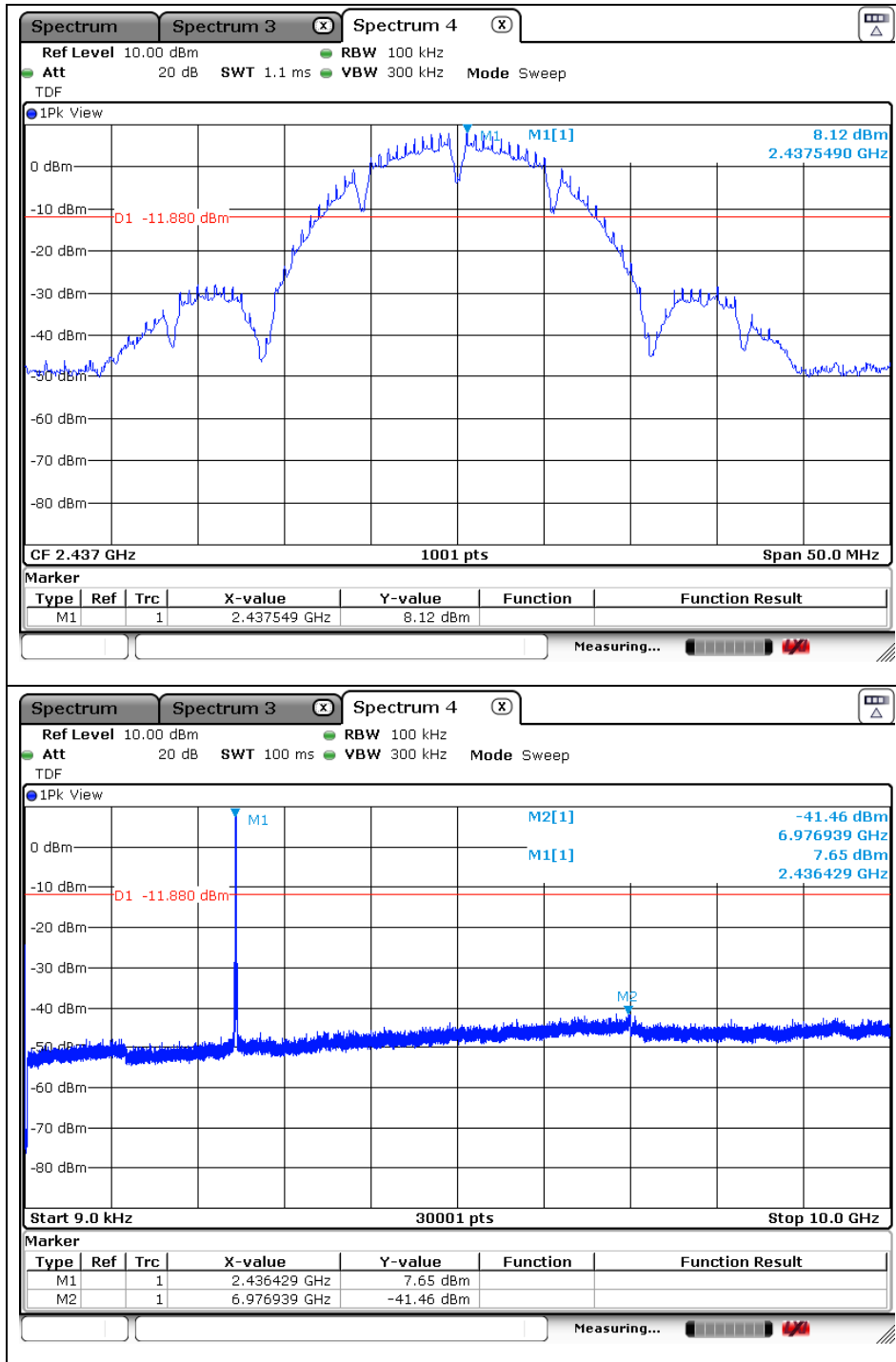

The results shown in this test report refer only to the sample(s) tested unless otherwise stated. This test report cannot be reproduced, except in full, without prior written permission of the Company. This test report does not assure KOLAS accreditation.

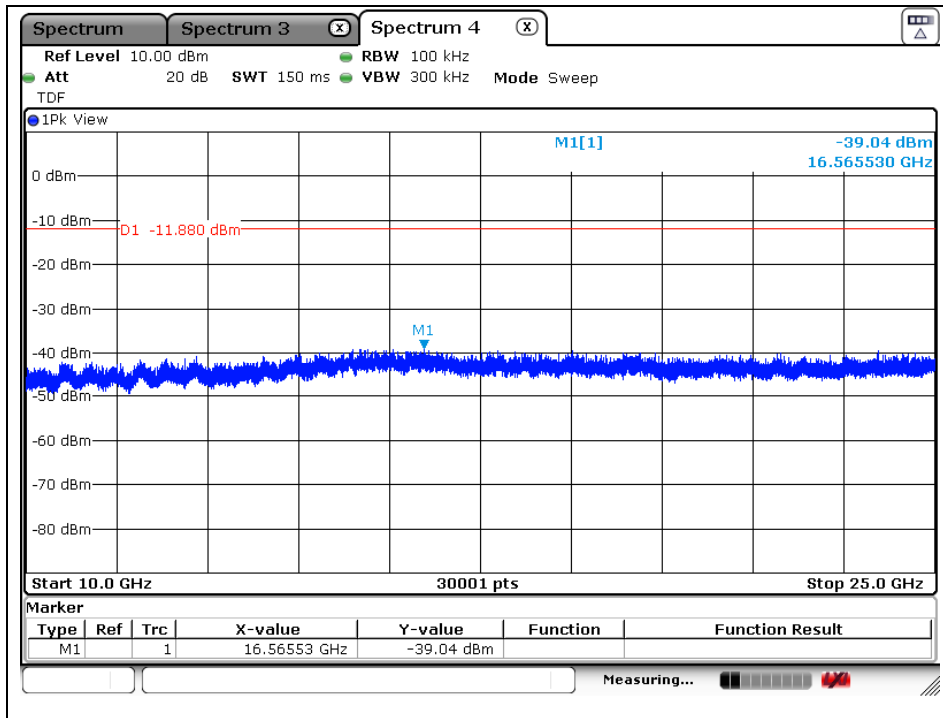

The results shown in this test report refer only to the sample(s) tested unless otherwise stated. This test report cannot be reproduced, except in full, without prior written permission of the Company. This test report does not assure KOLAS accreditation.

High Channel

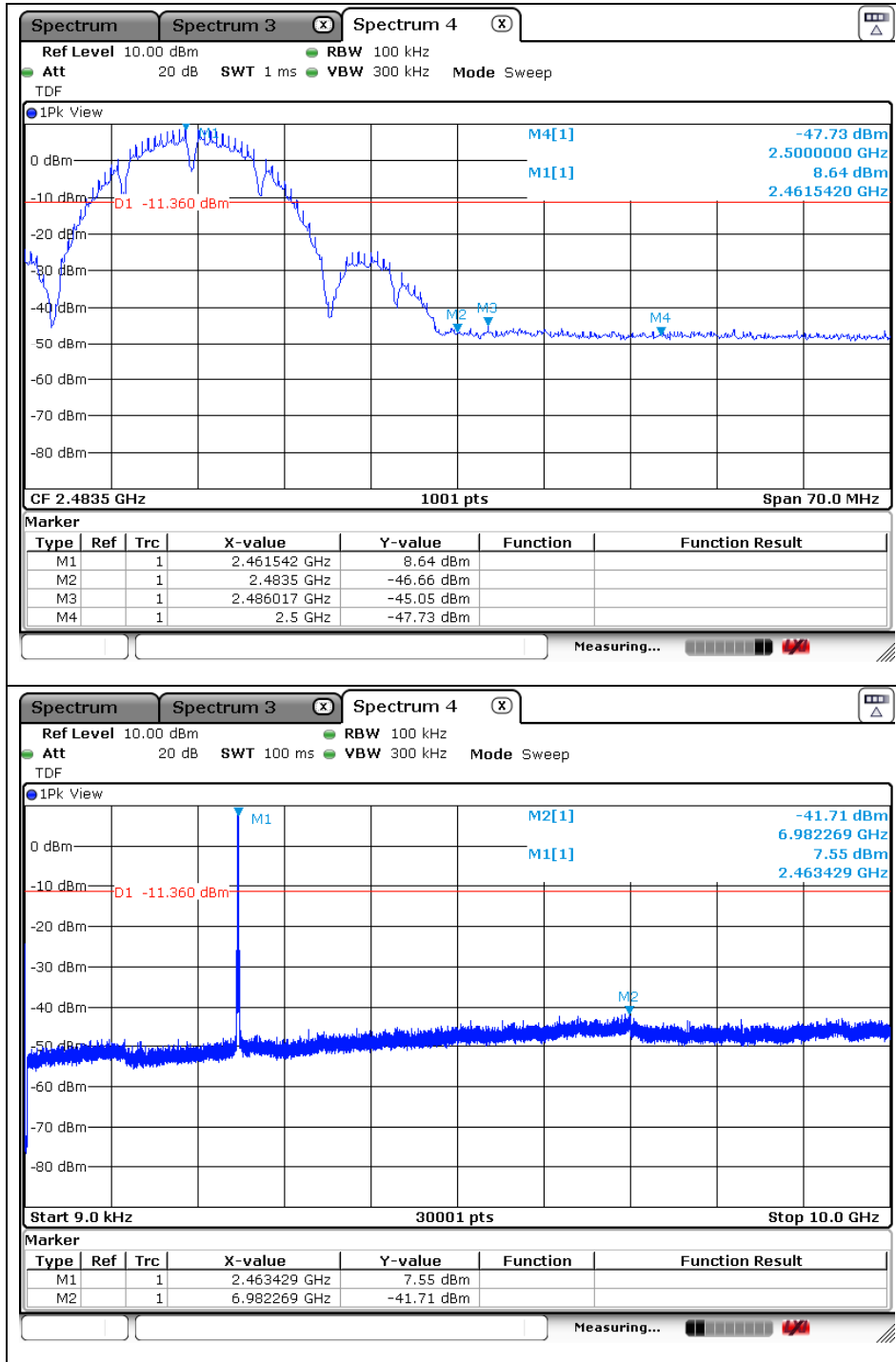

The results shown in this test report refer only to the sample(s) tested unless otherwise stated. This test report cannot be reproduced, except in full, without prior written permission of the Company. This test report does not assure KOLAS accreditation.

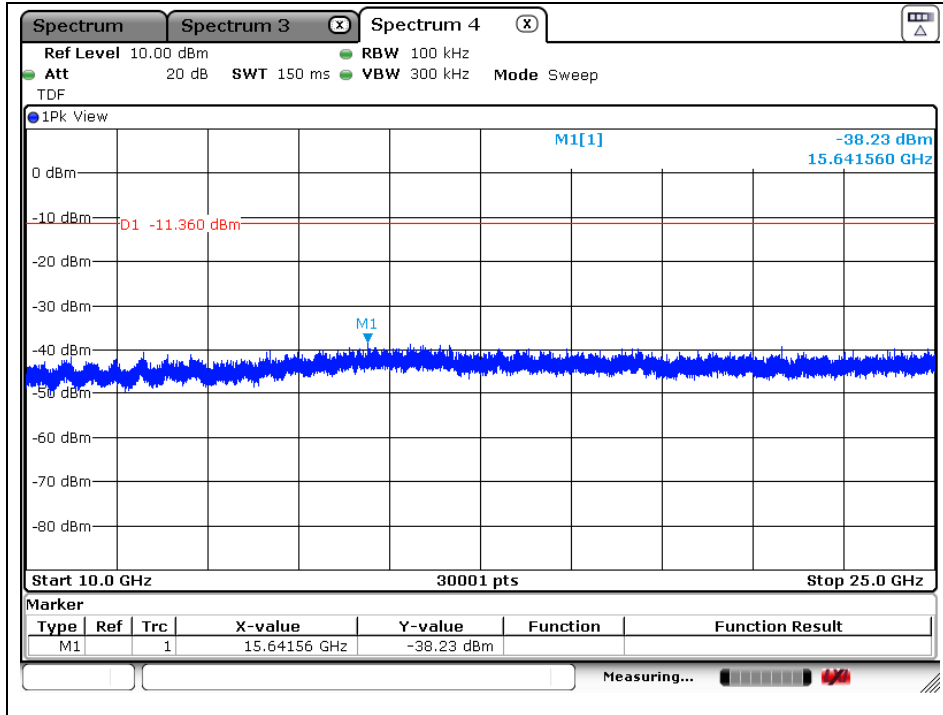

The results shown in this test report refer only to the sample(s) tested unless otherwise stated. This test report cannot be reproduced, except in full, without prior written permission of the Company. This test report does not assure KOLAS accreditation.

OFDM: 802.11g (6 Mbps)

Low Channel

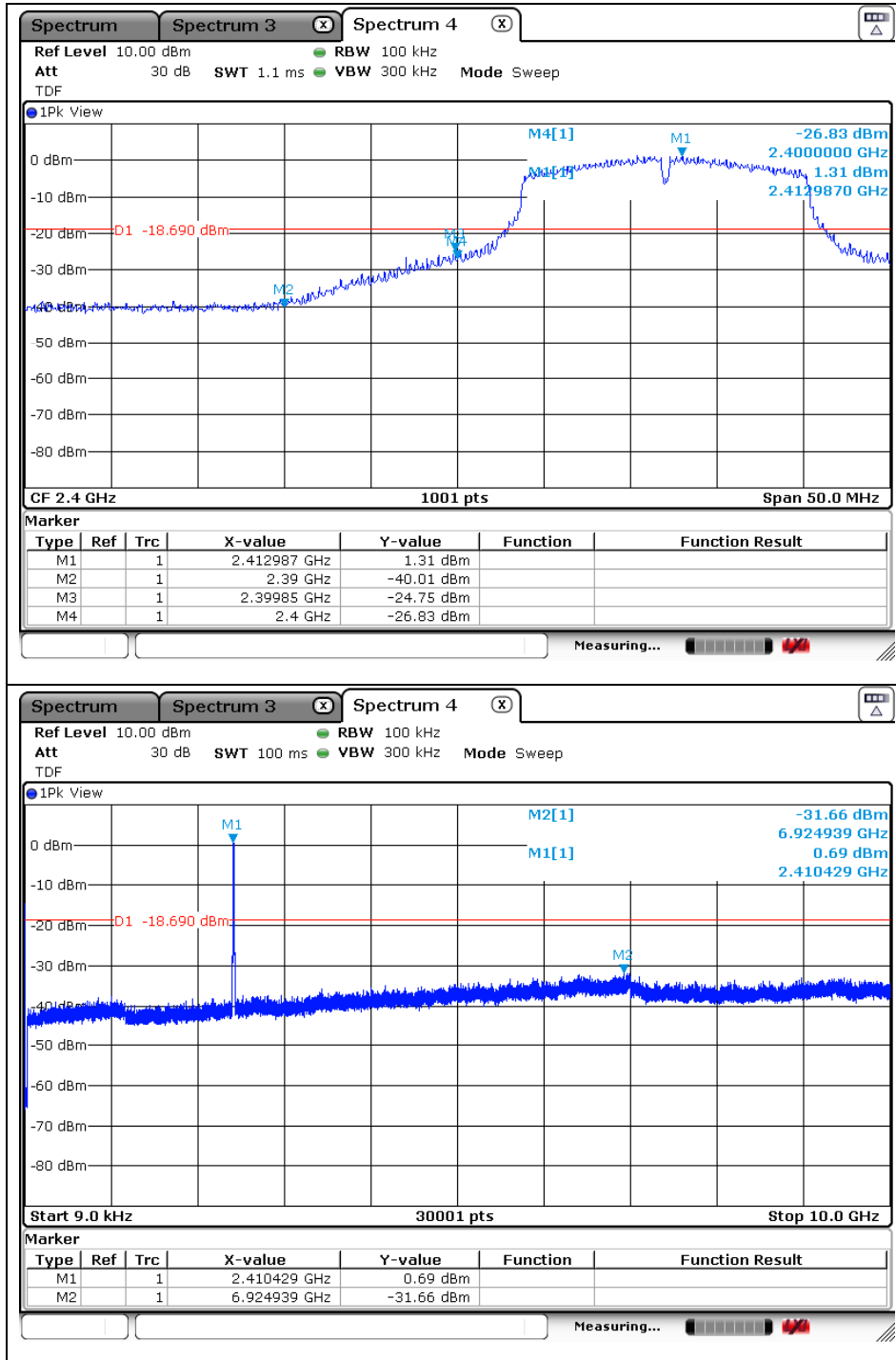

The results shown in this test report refer only to the sample(s) tested unless otherwise stated. This test report cannot be reproduced, except in full, without prior written permission of the Company. This test report does not assure KOLAS accreditation.

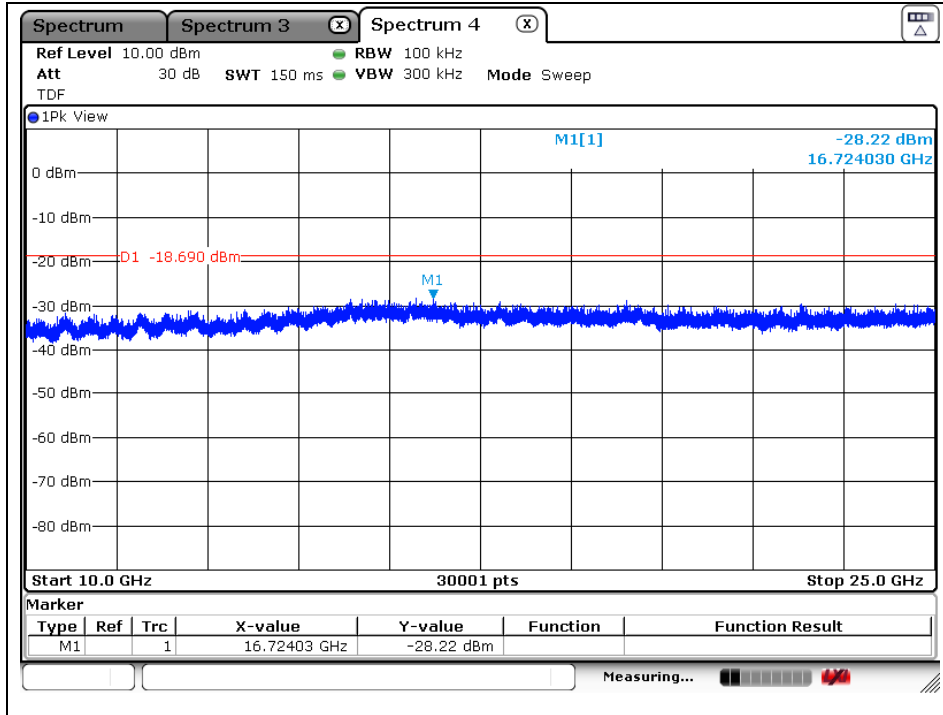

The results shown in this test report refer only to the sample(s) tested unless otherwise stated. This test report cannot be reproduced, except in full, without prior written permission of the Company. This test report does not assure KOLAS accreditation.

Middle Channel

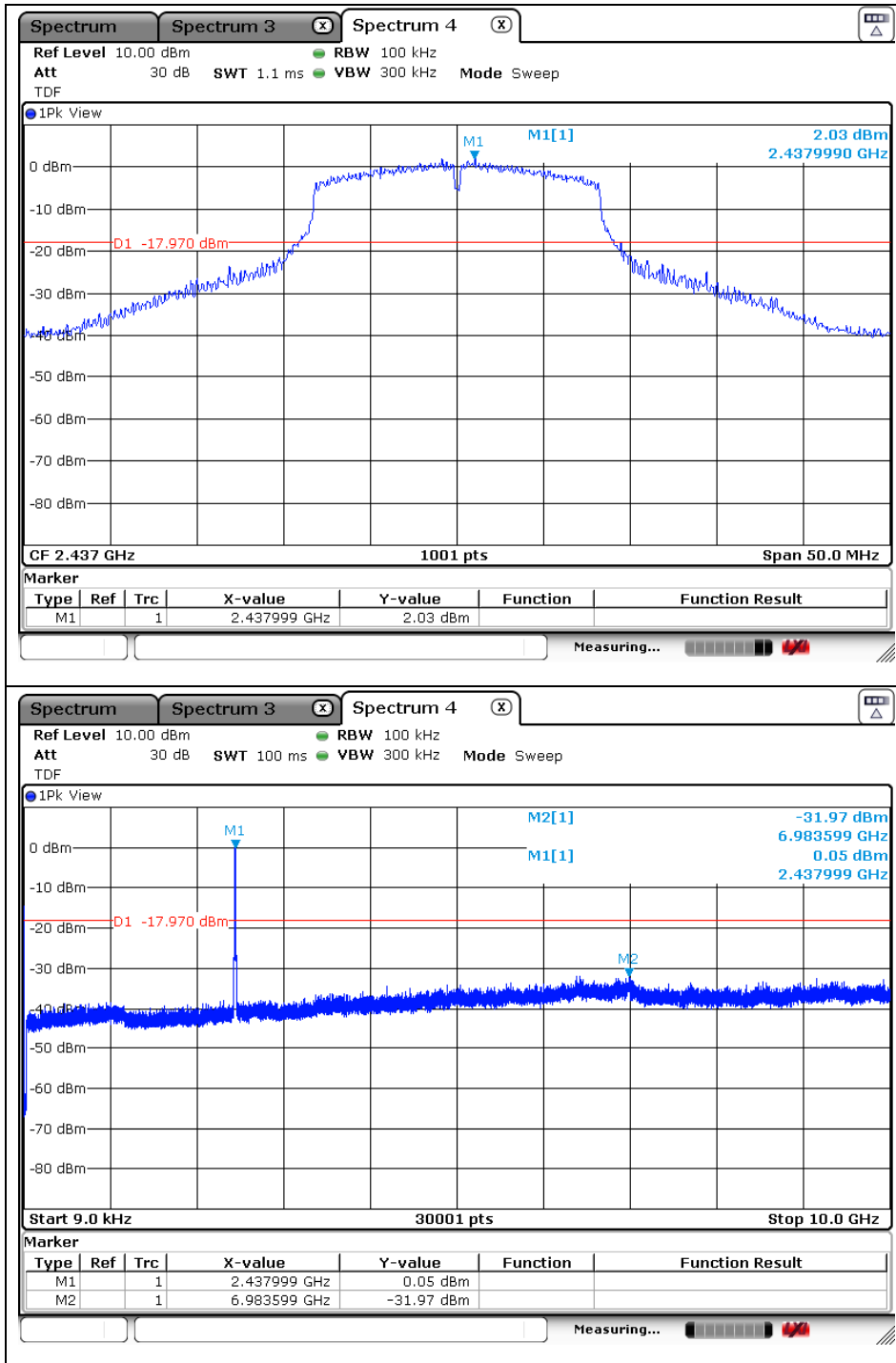

The results shown in this test report refer only to the sample(s) tested unless otherwise stated. This test report cannot be reproduced, except in full, without prior written permission of the Company. This test report does not assure KOLAS accreditation.

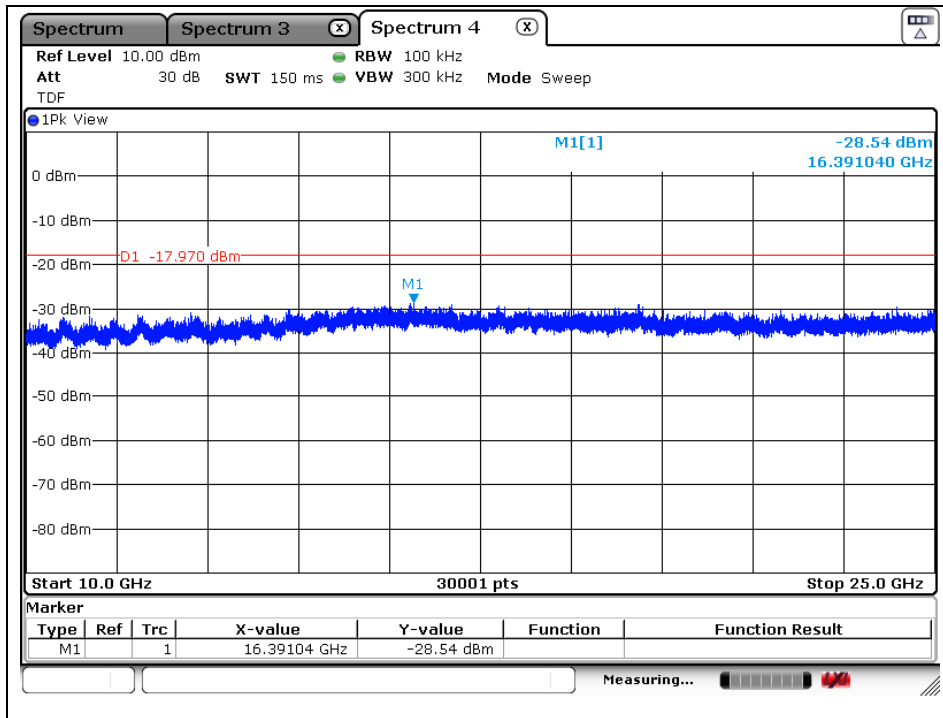

The results shown in this test report refer only to the sample(s) tested unless otherwise stated. This test report cannot be reproduced, except in full, without prior written permission of the Company. This test report does not assure KOLAS accreditation.

High Channel

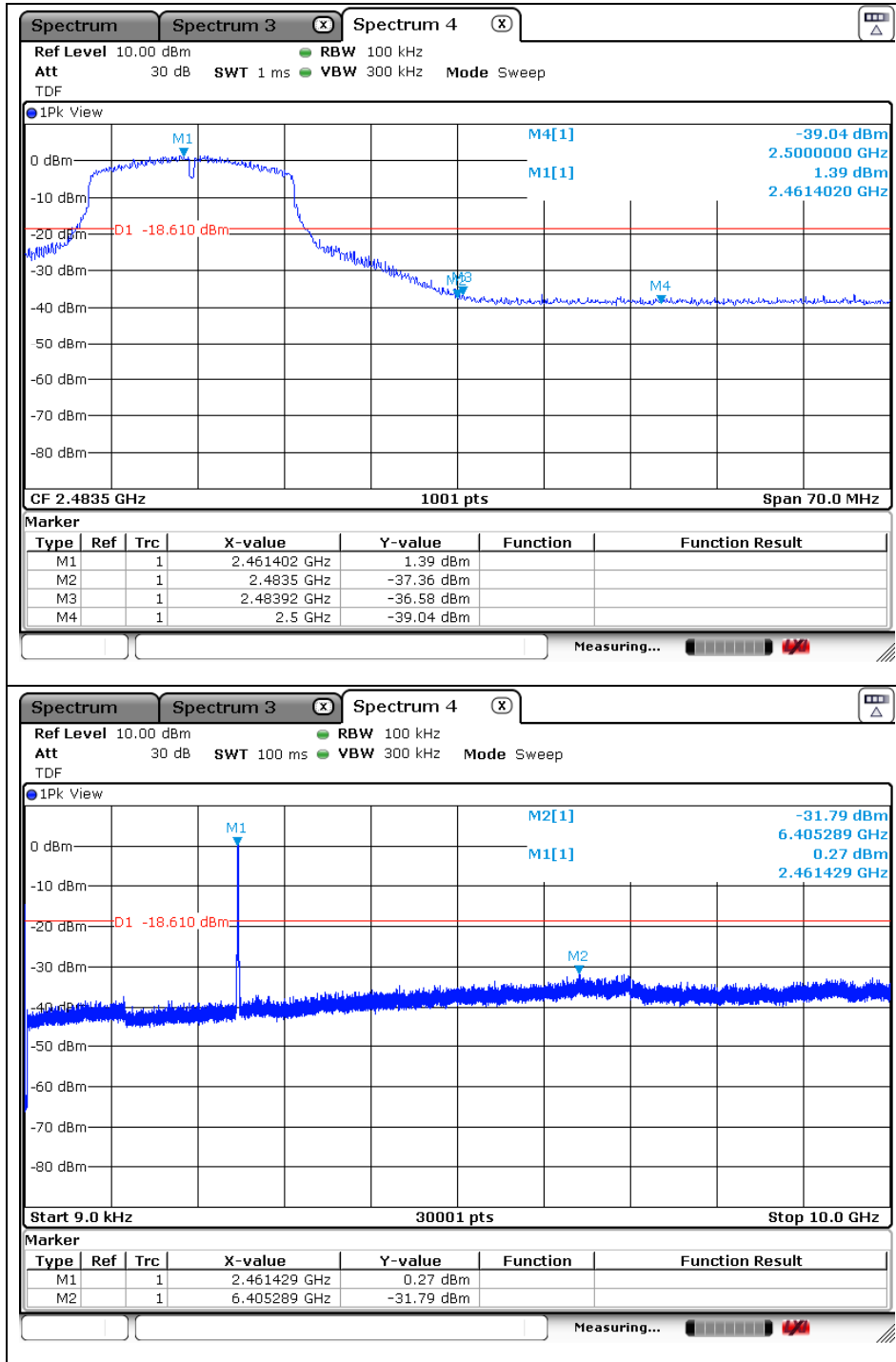

The results shown in this test report refer only to the sample(s) tested unless otherwise stated. This test report cannot be reproduced, except in full, without prior written permission of the Company. This test report does not assure KOLAS accreditation.

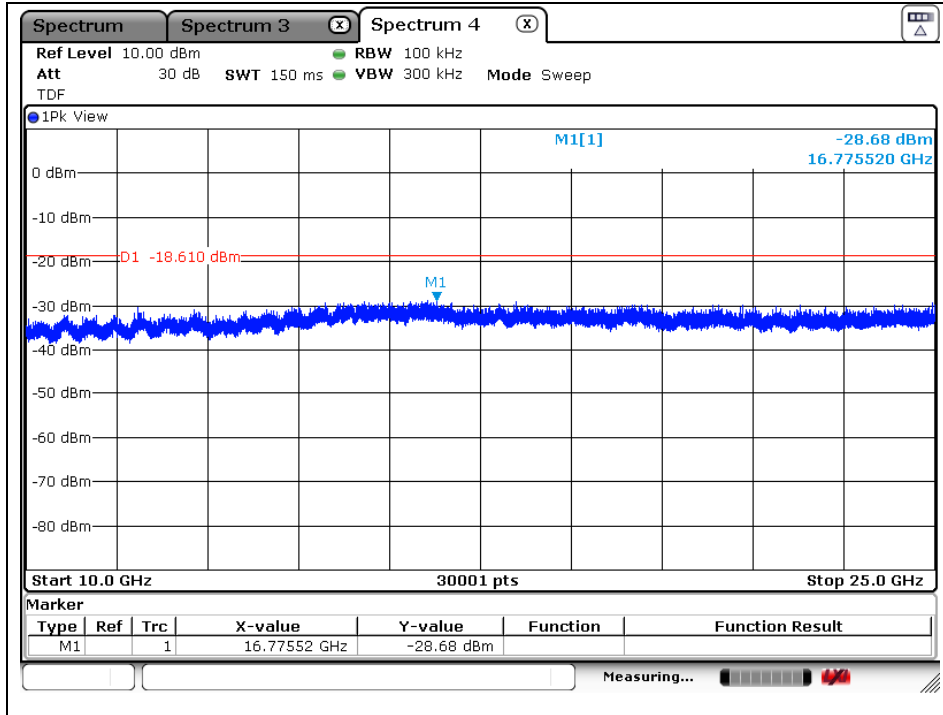

The results shown in this test report refer only to the sample(s) tested unless otherwise stated. This test report cannot be reproduced, except in full, without prior written permission of the Company. This test report does not assure KOLAS accreditation.

OFDM: 802.11n_HT20 (MCS0)

Low Channel

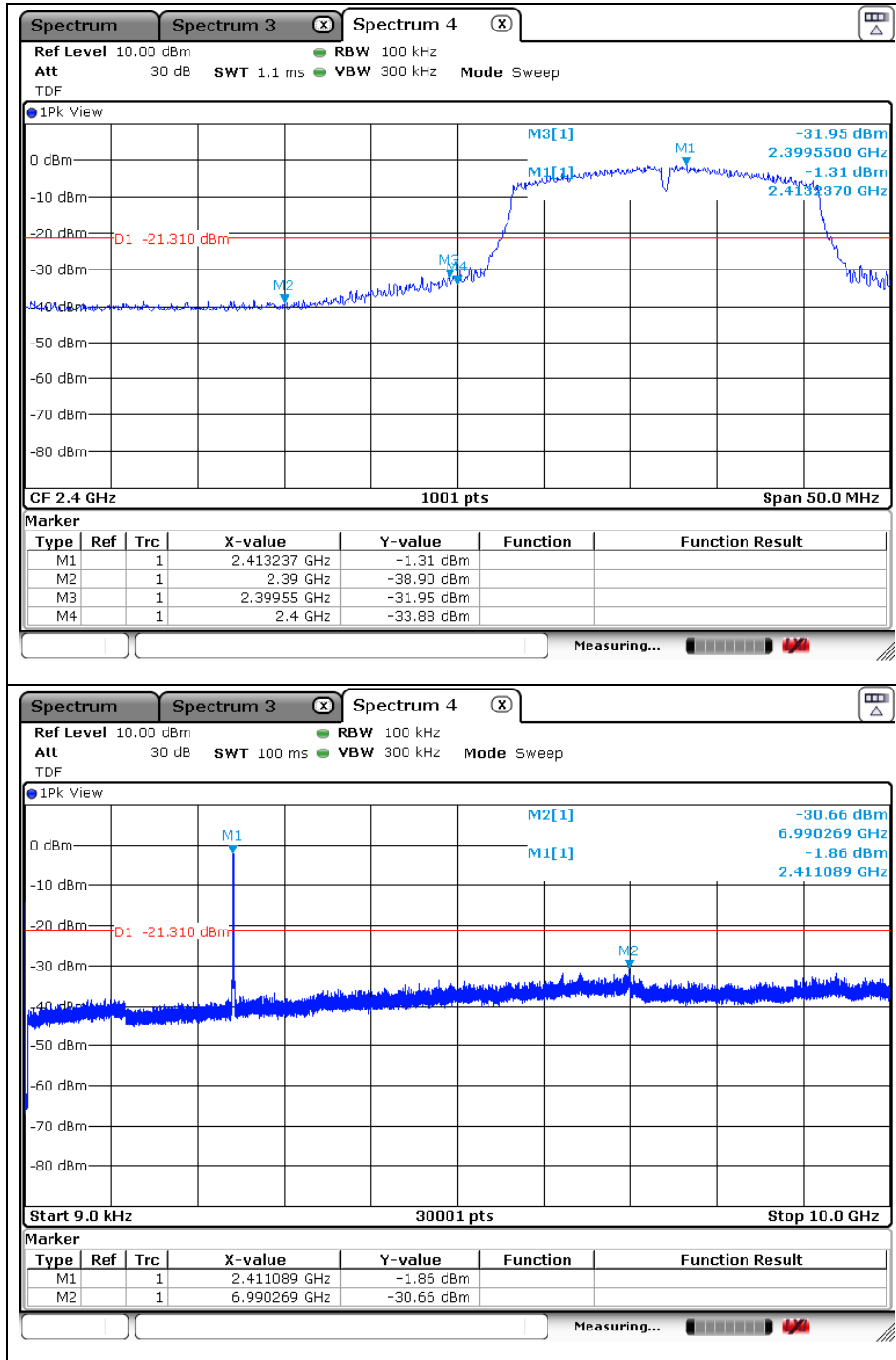

The results shown in this test report refer only to the sample(s) tested unless otherwise stated. This test report cannot be reproduced, except in full, without prior written permission of the Company. This test report does not assure KOLAS accreditation.

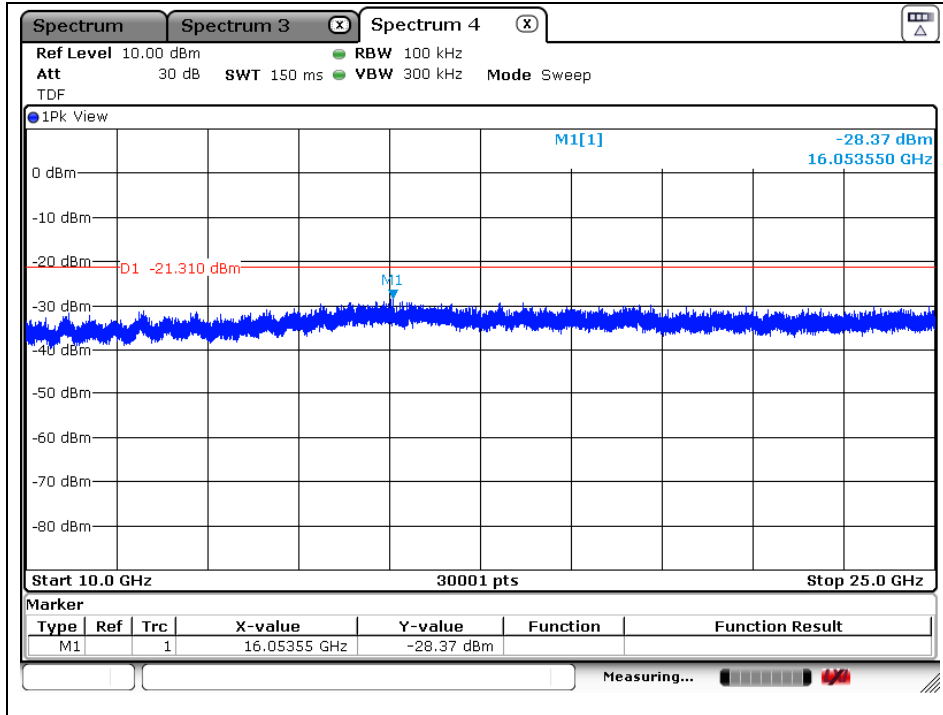

The results shown in this test report refer only to the sample(s) tested unless otherwise stated. This test report cannot be reproduced, except in full, without prior written permission of the Company. This test report does not assure KOLAS accreditation.

Middle Channel

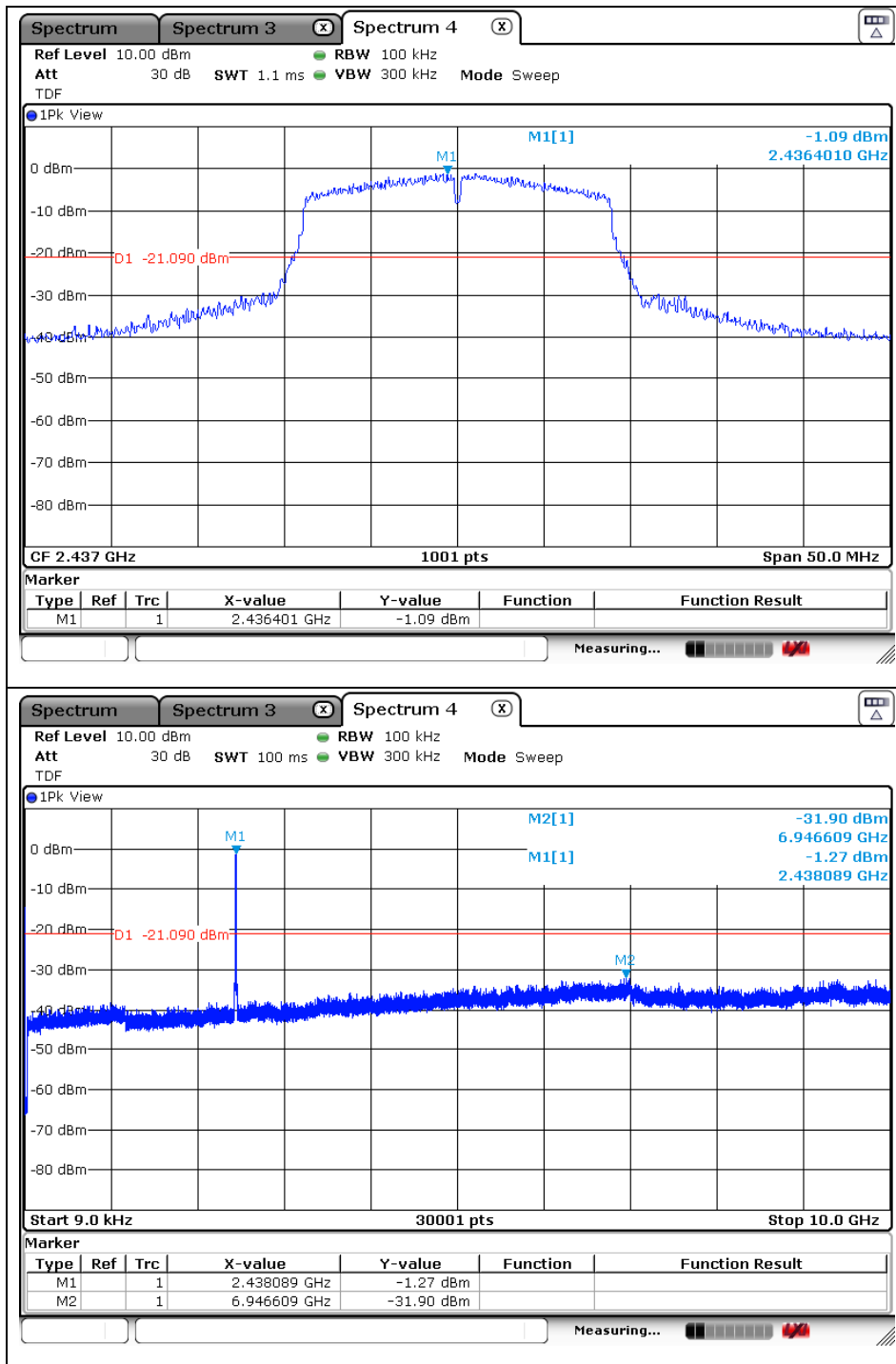

The results shown in this test report refer only to the sample(s) tested unless otherwise stated. This test report cannot be reproduced, except in full, without prior written permission of the Company. This test report does not assure KOLAS accreditation.

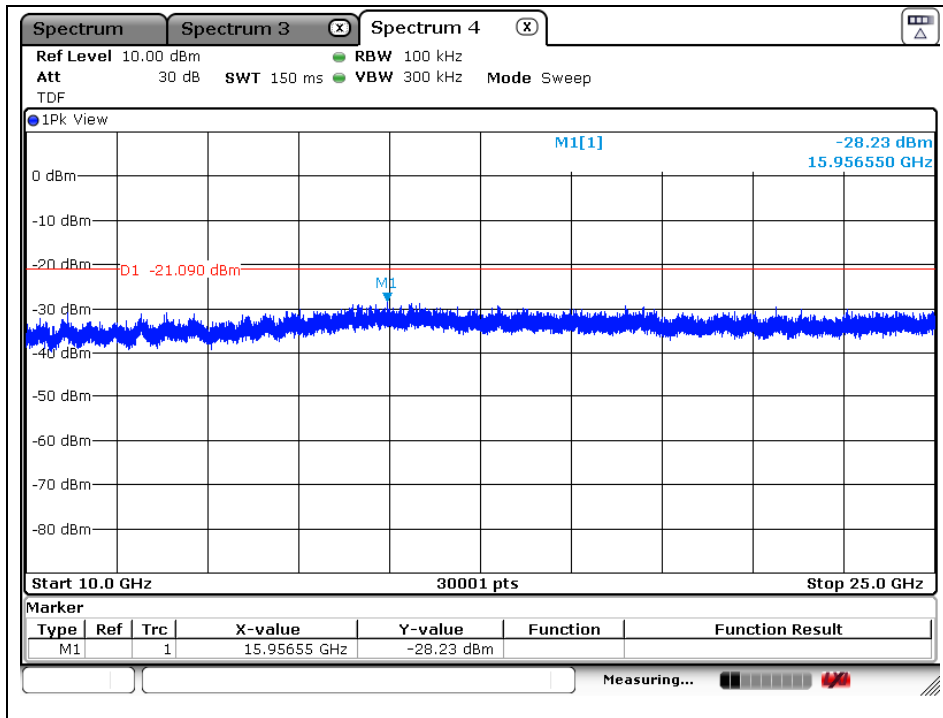

The results shown in this test report refer only to the sample(s) tested unless otherwise stated. This test report cannot be reproduced, except in full, without prior written permission of the Company. This test report does not assure KOLAS accreditation.

High Channel

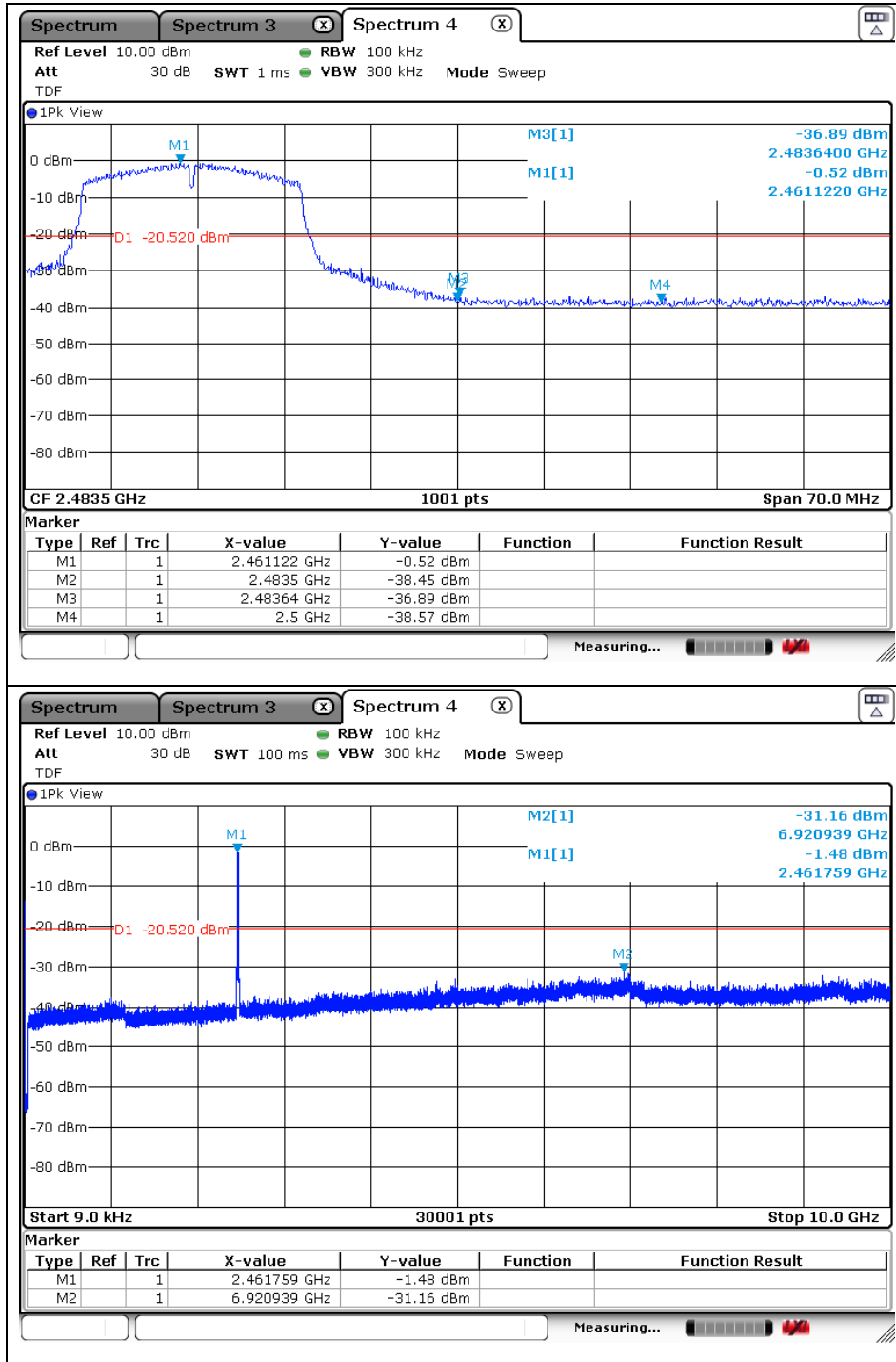

The results shown in this test report refer only to the sample(s) tested unless otherwise stated. This test report cannot be reproduced, except in full, without prior written permission of the Company. This test report does not assure KOLAS accreditation.

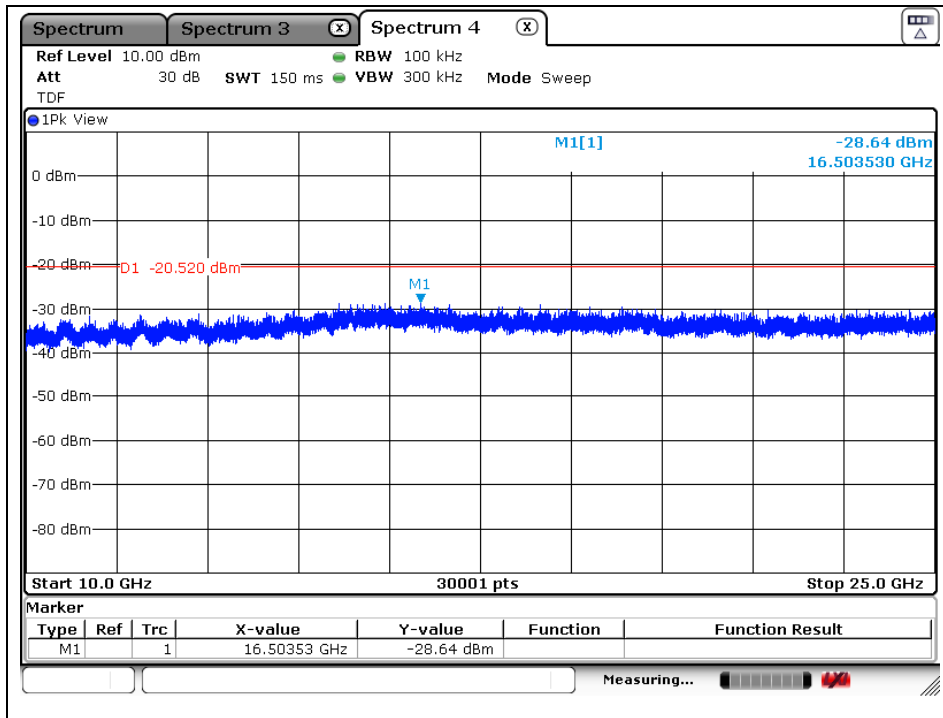

The results shown in this test report refer only to the sample(s) tested unless otherwise stated. This test report cannot be reproduced, except in full, without prior written permission of the Company. This test report does not assure KOLAS accreditation.

OFDM: 802.11n_HT40 (MCS0)

Low Channel

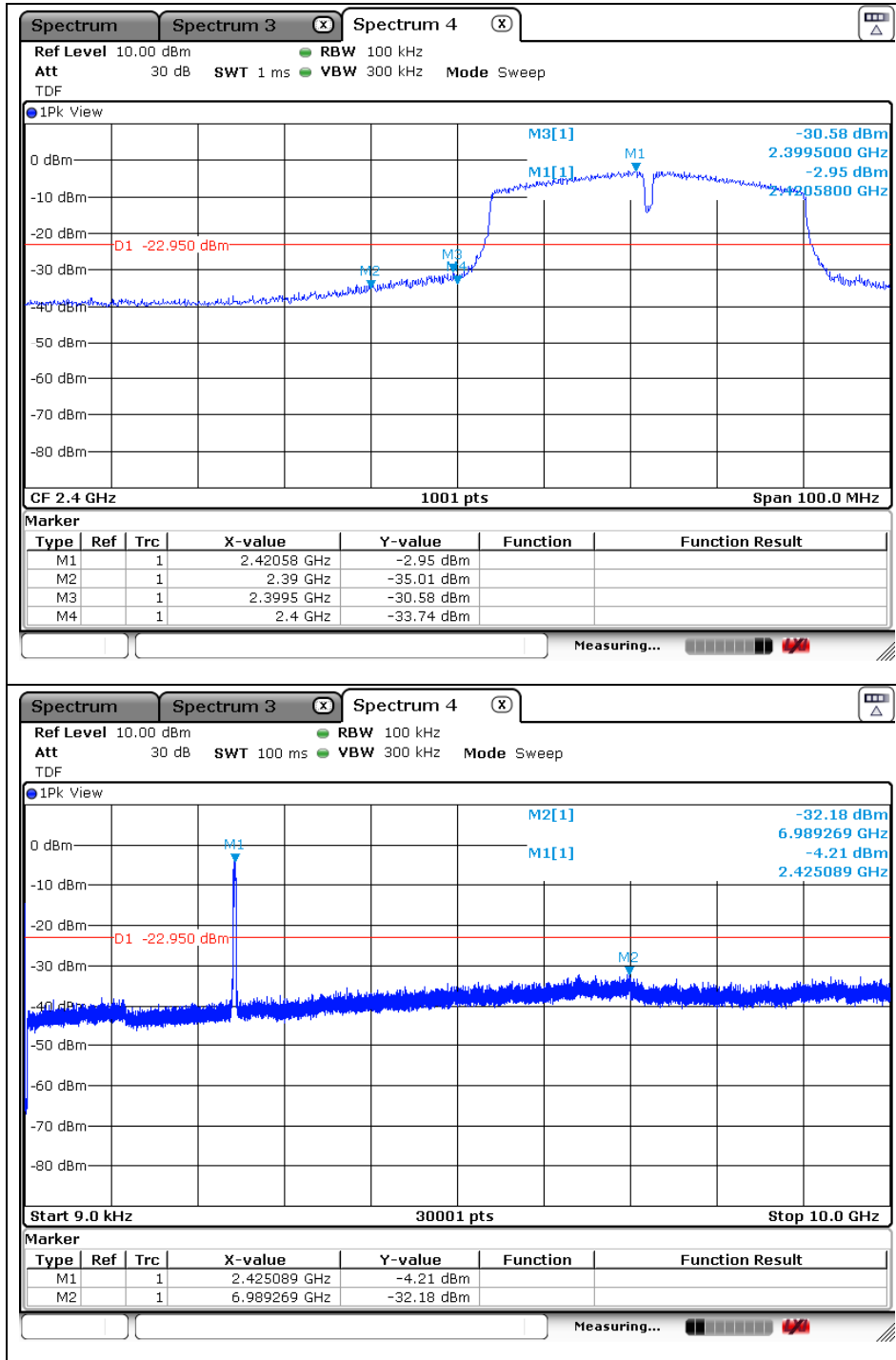

The results shown in this test report refer only to the sample(s) tested unless otherwise stated. This test report cannot be reproduced, except in full, without prior written permission of the Company. This test report does not assure KOLAS accreditation.

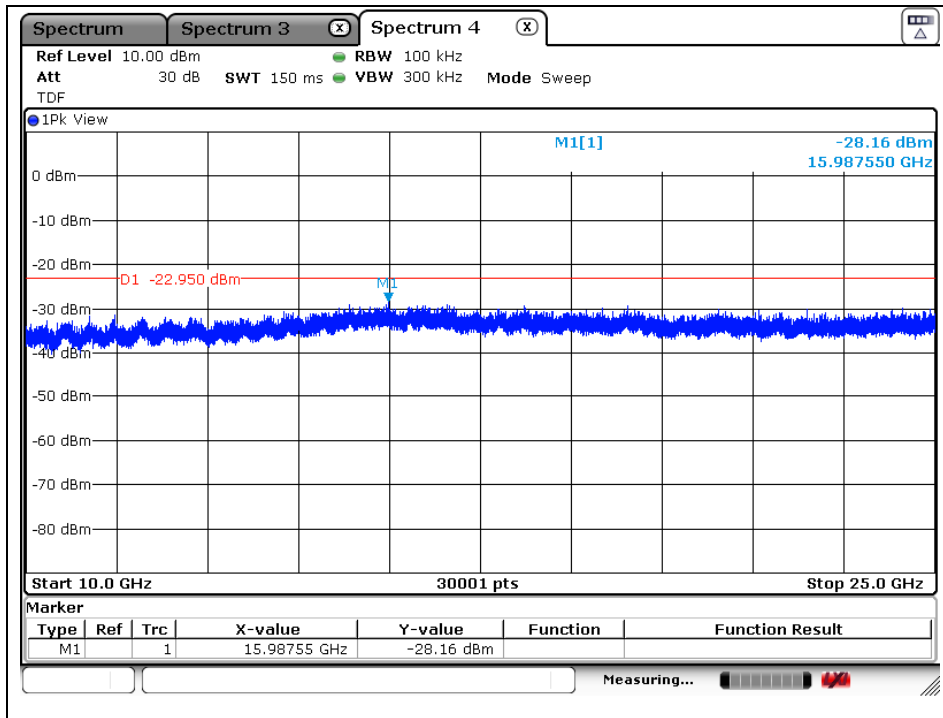

The results shown in this test report refer only to the sample(s) tested unless otherwise stated. This test report cannot be reproduced, except in full, without prior written permission of the Company. This test report does not assure KOLAS accreditation.

Middle Channel

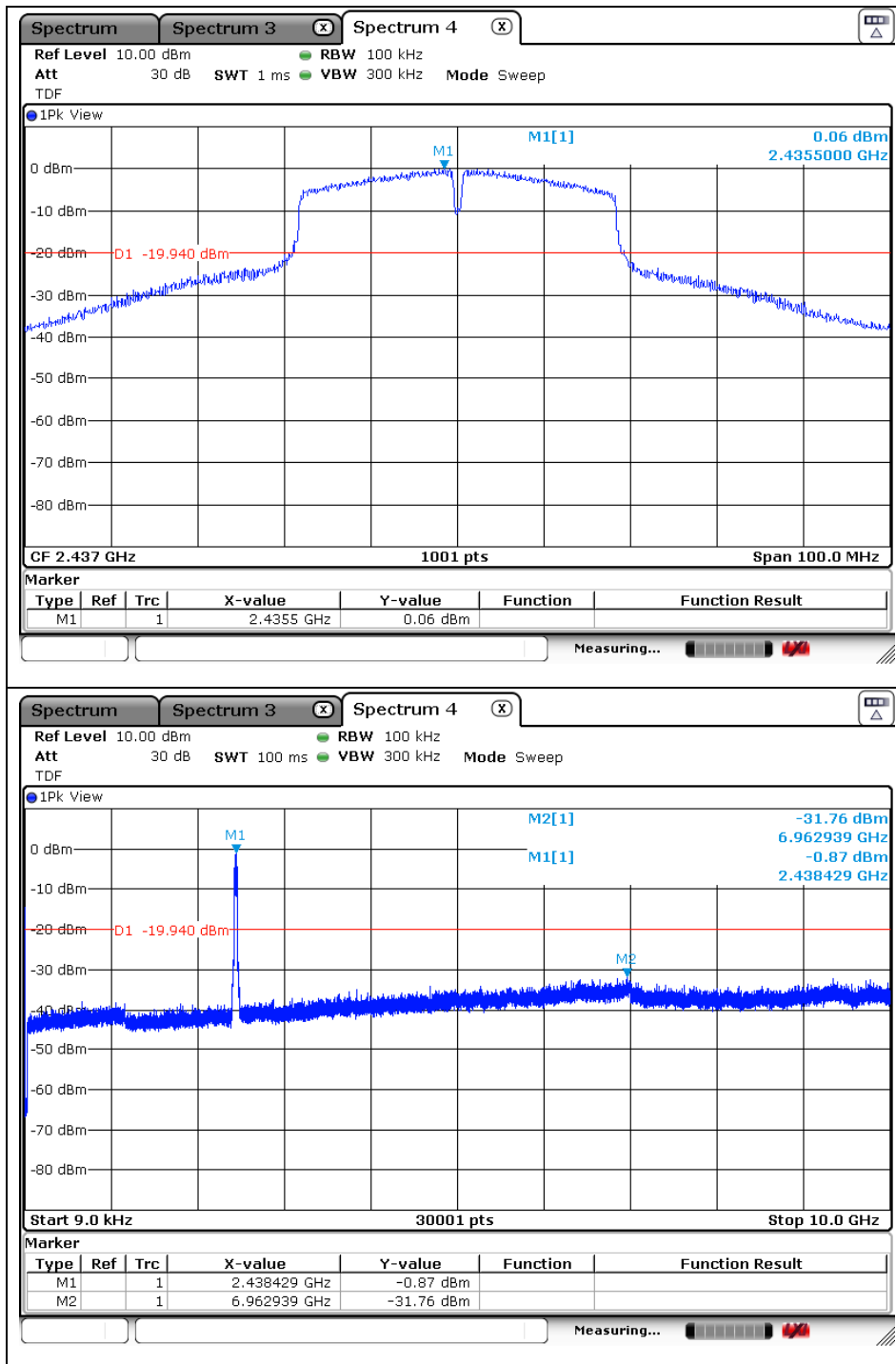

The results shown in this test report refer only to the sample(s) tested unless otherwise stated. This test report cannot be reproduced, except in full, without prior written permission of the Company. This test report does not assure KOLAS accreditation.

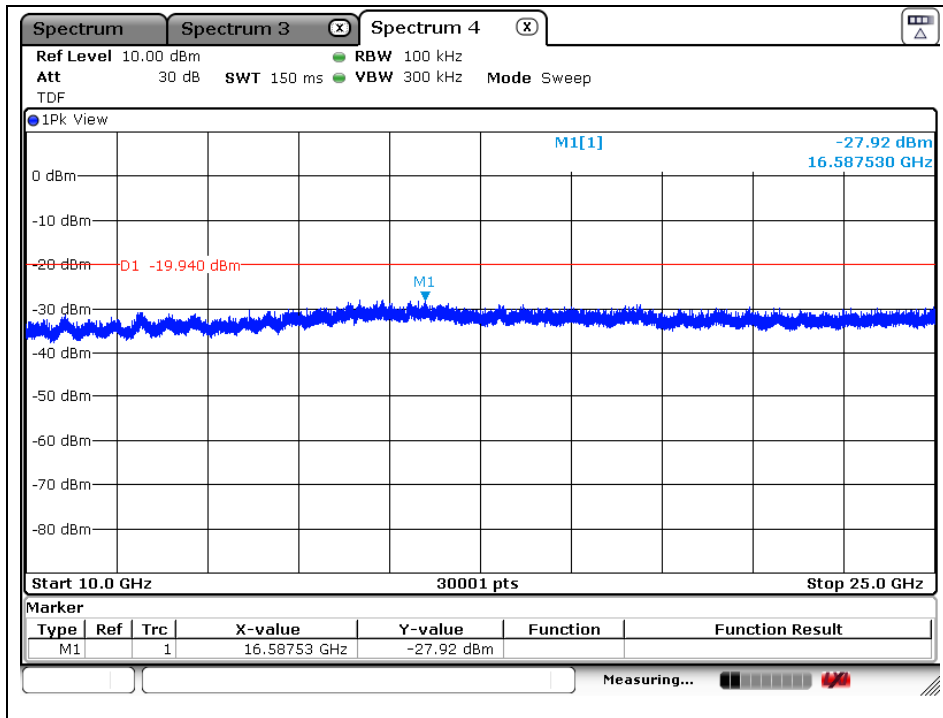

The results shown in this test report refer only to the sample(s) tested unless otherwise stated. This test report cannot be reproduced, except in full, without prior written permission of the Company. This test report does not assure KOLAS accreditation.

High Channel

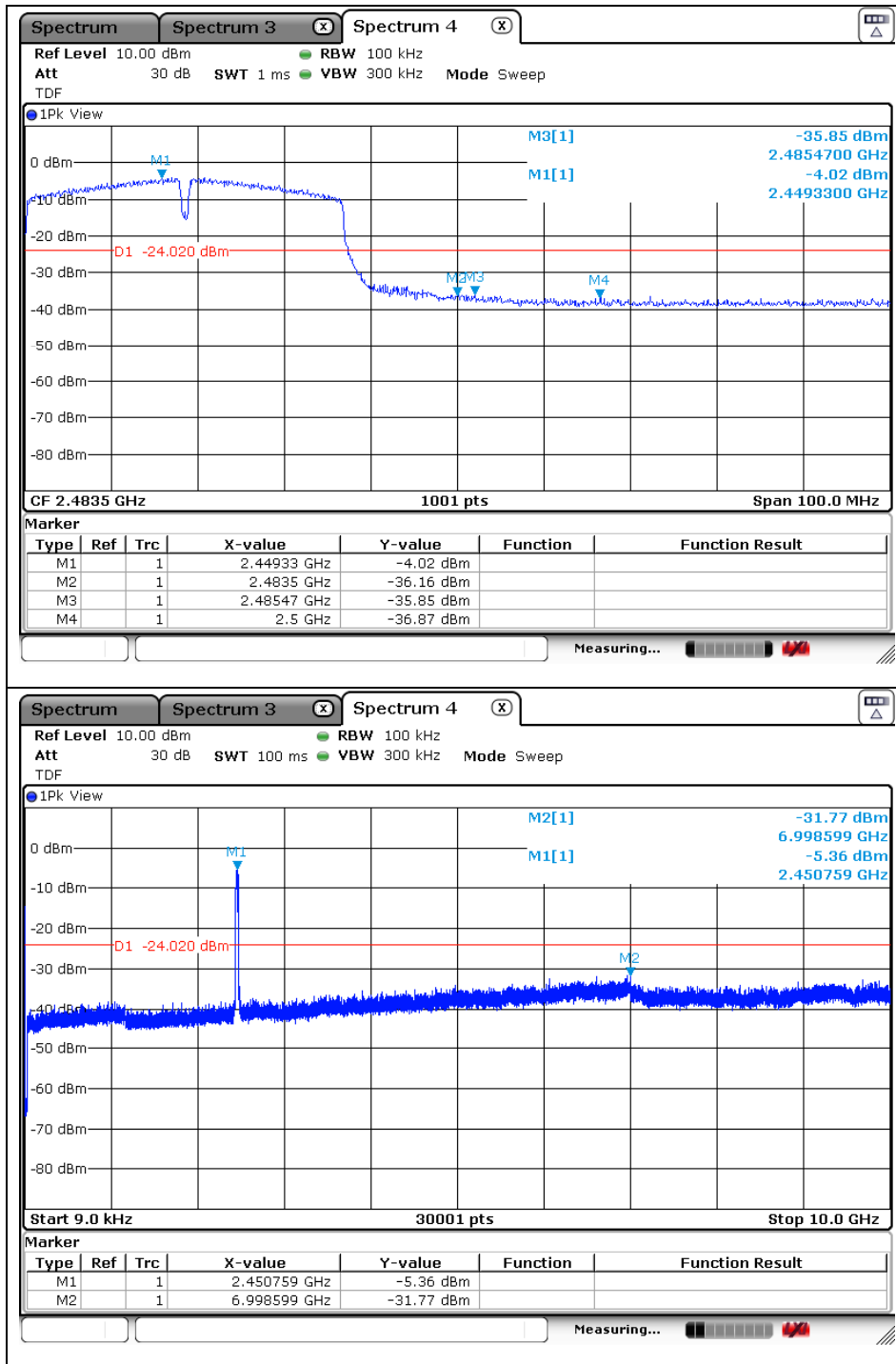

The results shown in this test report refer only to the sample(s) tested unless otherwise stated. This test report cannot be reproduced, except in full, without prior written permission of the Company. This test report does not assure KOLAS accreditation.

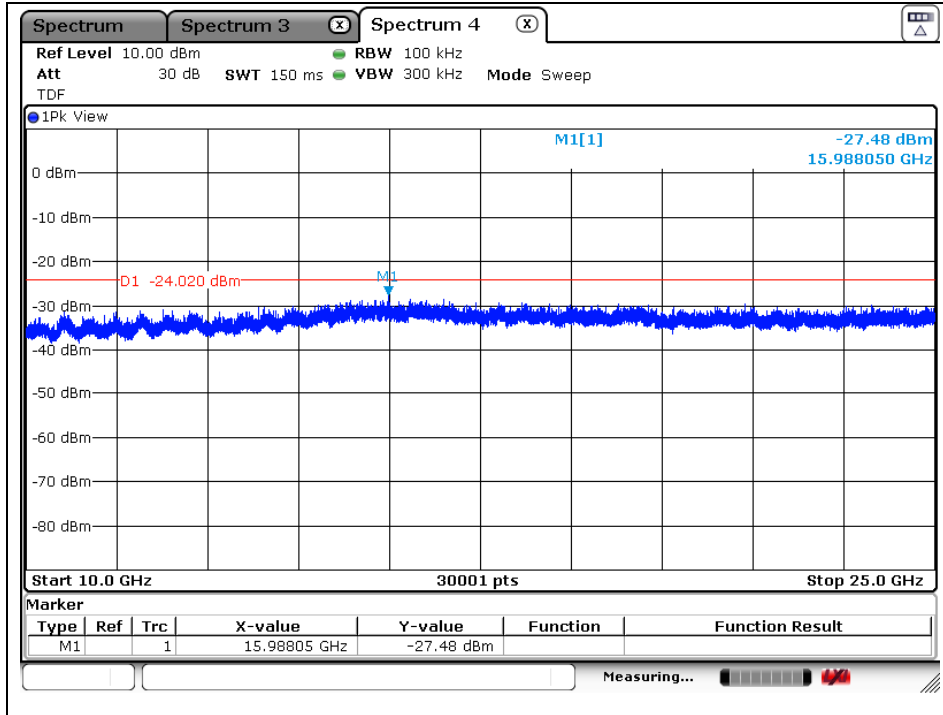

The results shown in this test report refer only to the sample(s) tested unless otherwise stated. This test report cannot be reproduced, except in full, without prior written permission of the Company. This test report does not assure KOLAS accreditation.

3. 6 dB Bandwidth

3.1. Test Setup

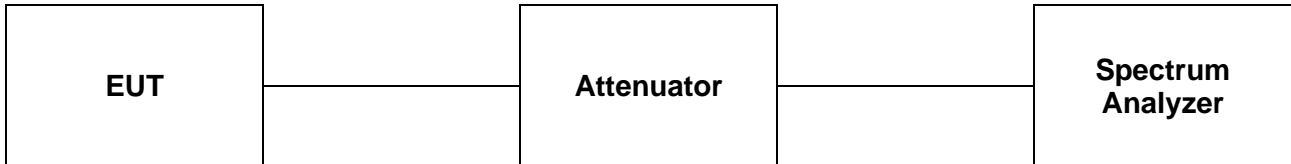

3.2. Limit

§15.247(a)(2), systems using digital modulation techniques may operate in the 902-928 MHz, 2 400-2 483.5 MHz, and 5 725-5 850 MHz bands. The minimum of 6 dB Bandwidth shall be at least 500 kHz.

3.3. Test Procedure

3.3.1. 6 dB Bandwidth

All data rates and modes were investigated for this test. The full data for the worst case data rate are reported in this section

The test follows section 8.0 DTS bandwidth of KDB 558074 D01 DTS Meas Guidance v04.
Tests performed using section 8.1 Option 1.

- Option 1:

1. Set RBW = 100 kHz.
2. Set the video bandwidth (VBW) $\geq 3 \times$ RBW.
3. Detector = Peak.
4. Trace mode = max hold.
5. Sweep = auto couple.
6. Allow the trace to stabilize.
7. Measure the maximum width of the emission that is constrained by the frequencies associated with the two outermost amplitude point (upper and lower frequencies) that are attenuated by 6 dB relative to the maximum level measured in the fundamental emission.

The results shown in this test report refer only to the sample(s) tested unless otherwise stated. This test report cannot be reproduced, except in full, without prior written permission of the Company. This test report does not assure KOLAS accreditation.

3.4. Test Results

Ambient temperature : (23 ± 1) °C
 Relative humidity : 47 % R.H.

| Operation Mode | Data Rate | Channel | Frequency (MHz) | 6 dB Bandwidth (MHz) |
|------------------------|-----------|---------|-----------------|----------------------|
| DSSS (802.11b) | 1 Mbps | Low | 2 412 | 10.170 |
| | | Middle | 2 437 | 10.030 |
| | | High | 2 462 | 9.910 |
| OFDM (802.11g) | 6 Mbps | Low | 2 412 | 16.294 |
| | | Middle | 2 437 | 16.319 |
| | | High | 2 462 | 16.304 |
| OFDM (802.11n_HT20) | MCS0 | Low | 2 412 | 17.532 |
| | | Middle | 2 437 | 17.557 |
| | | High | 2 462 | 17.502 |
| OFDM (802.11n_HT40) | MCS0 | Low | 2 422 | 35.804 |
| | | Middle | 2 437 | 35.085 |
| | | High | 2 452 | 35.884 |

The results shown in this test report refer only to the sample(s) tested unless otherwise stated. This test report cannot be reproduced, except in full, without prior written permission of the Company. This test report does not assure KOLAS accreditation.

6 dB Bandwidth

DSSS: 802.11b

Low Channel

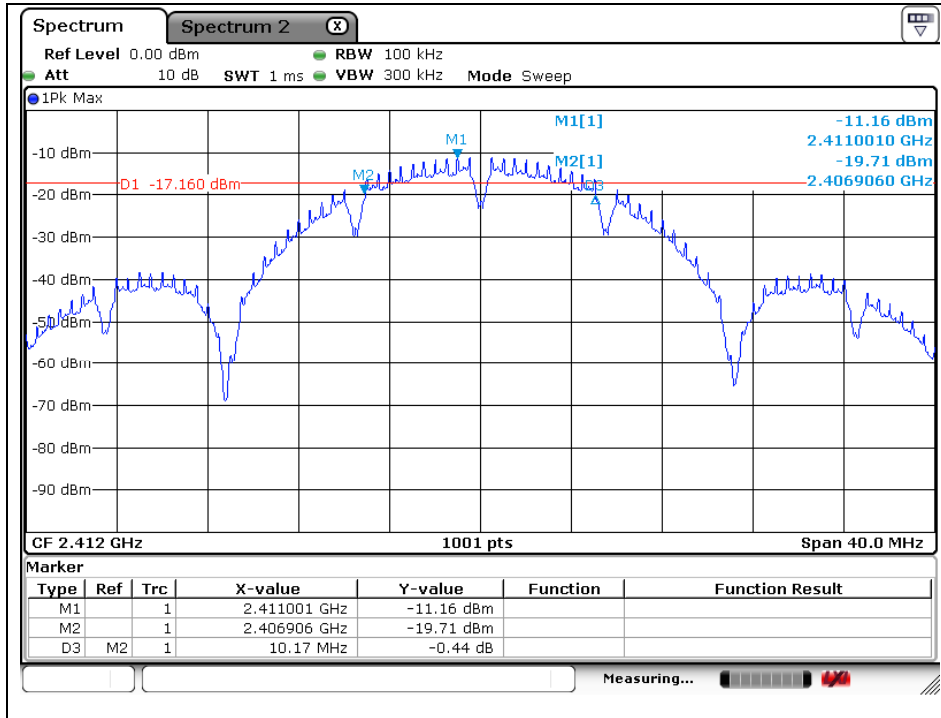

Middle Channel

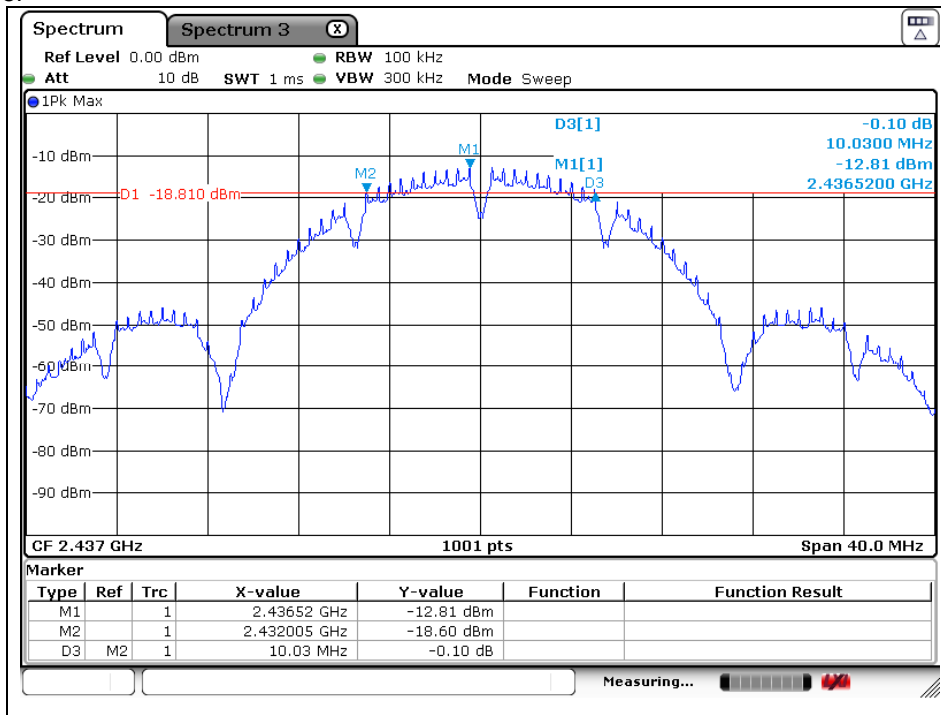

The results shown in this test report refer only to the sample(s) tested unless otherwise stated. This test report cannot be reproduced, except in full, without prior written permission of the Company. This test report does not assure KOLAS accreditation.

High Channel

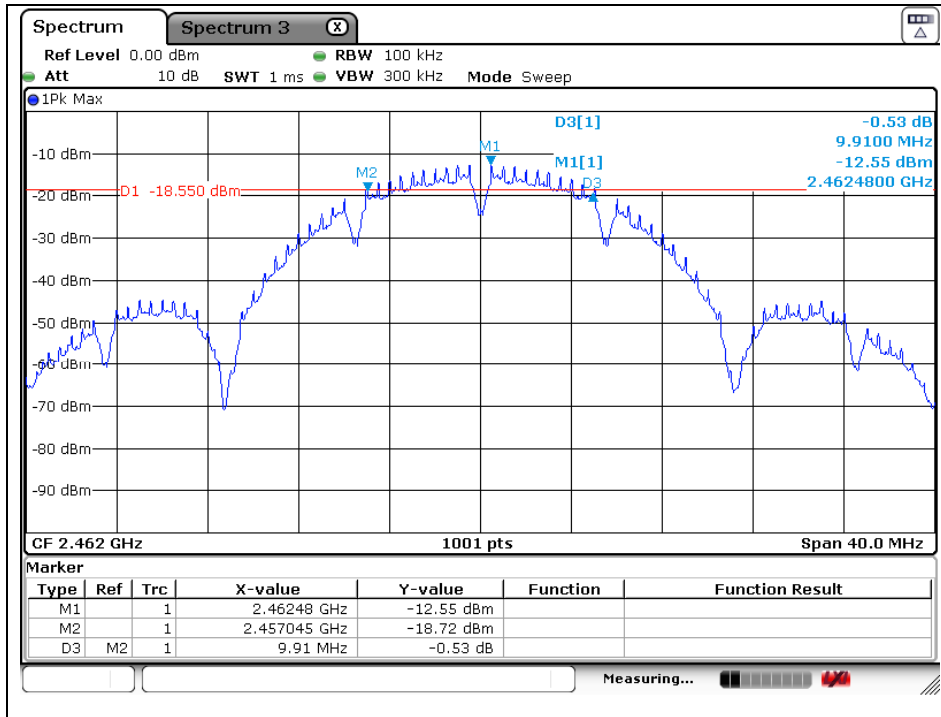

OFDM: 802.11g

Low Channel

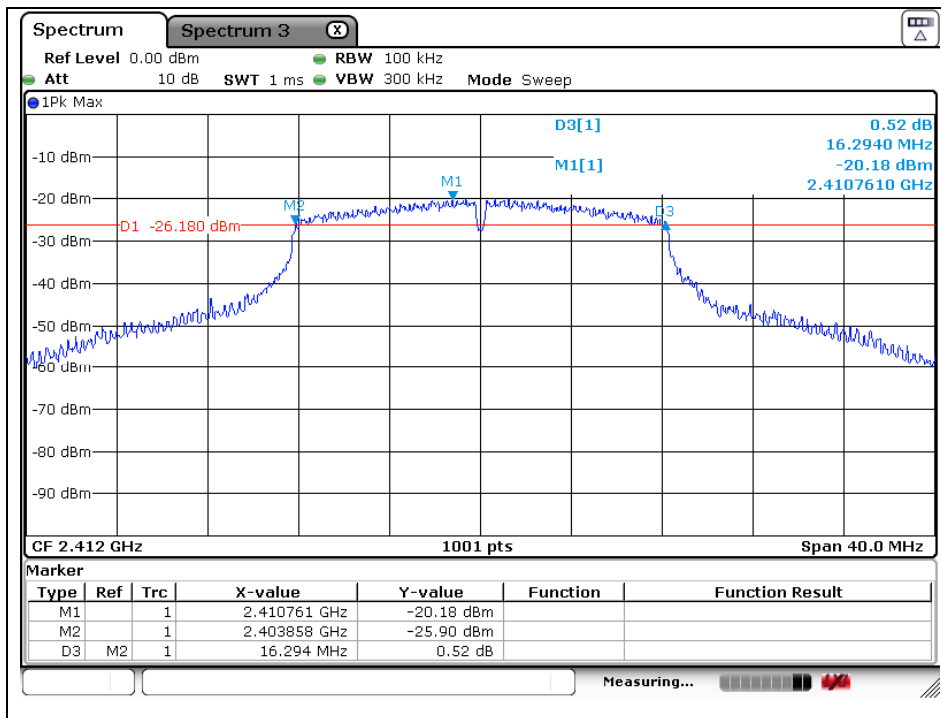

The results shown in this test report refer only to the sample(s) tested unless otherwise stated. This test report cannot be reproduced, except in full, without prior written permission of the Company. This test report does not assure KOLAS accreditation.

Middle Channel

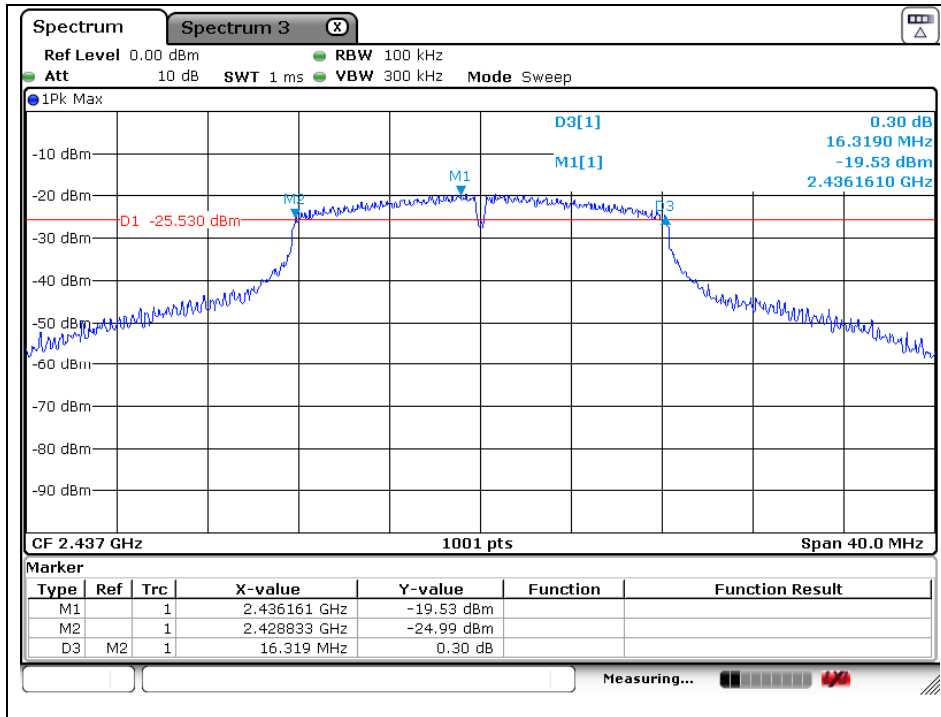

High Channel

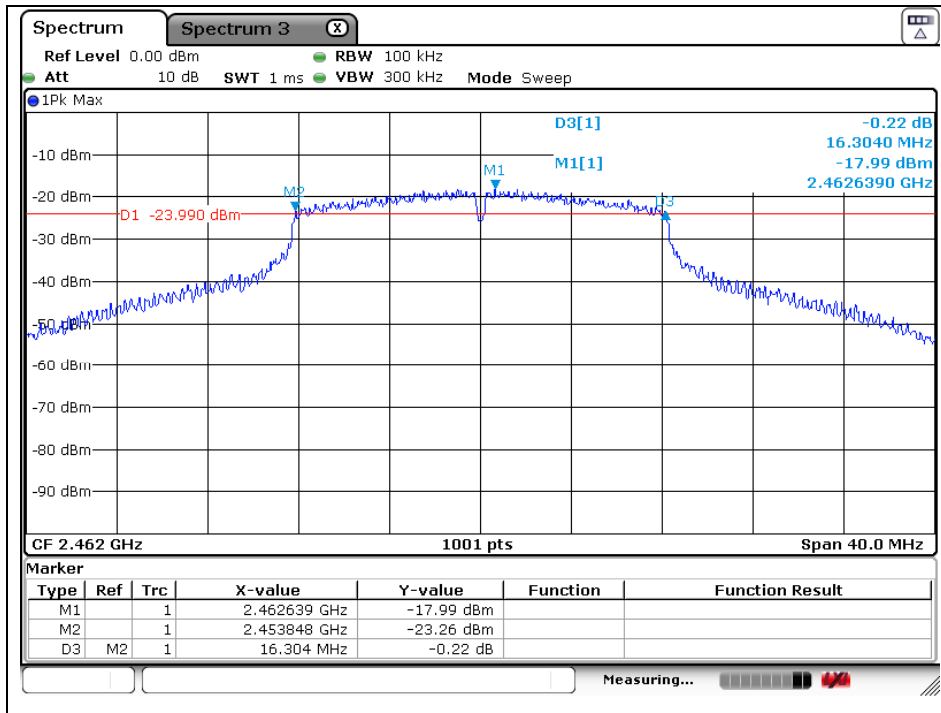

The results shown in this test report refer only to the sample(s) tested unless otherwise stated. This test report cannot be reproduced, except in full, without prior written permission of the Company. This test report does not assure KOLAS accreditation.

OFDM: 802.11n_HT20

Low Channel

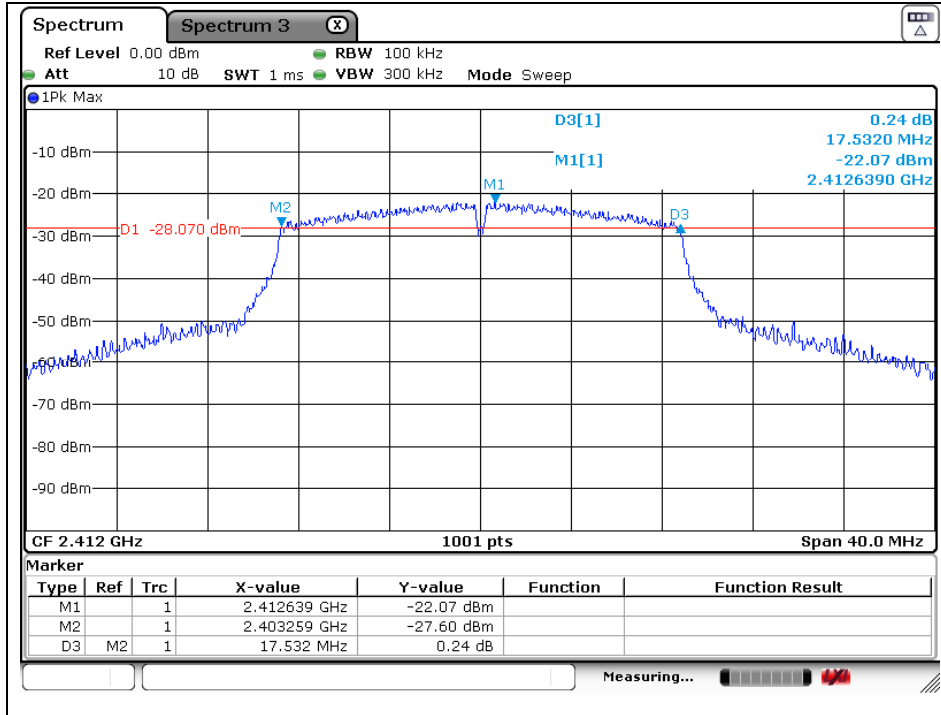

Middle Channel

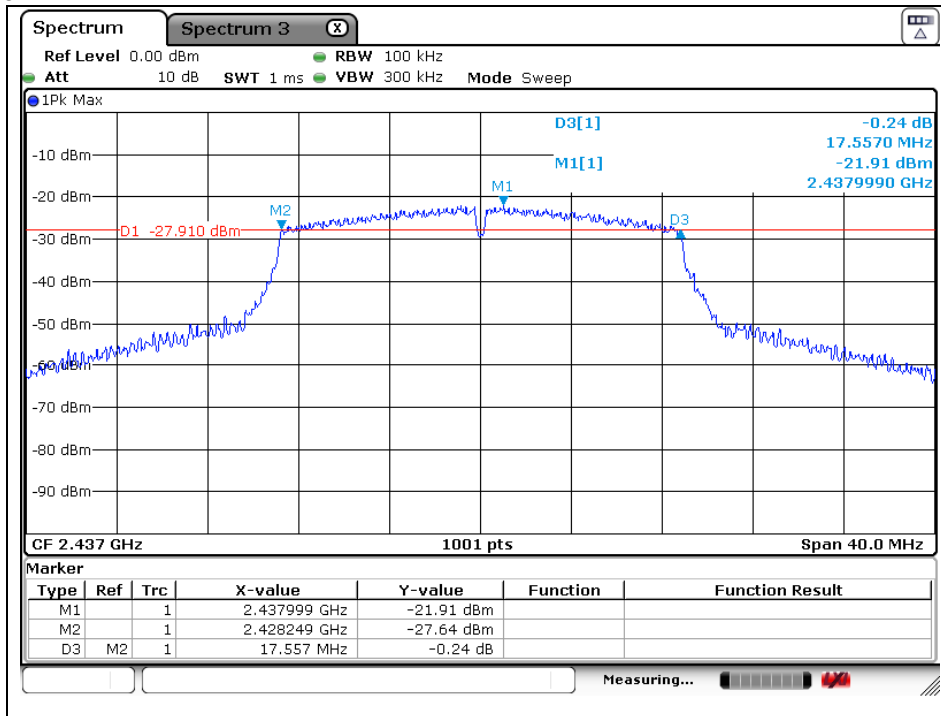

The results shown in this test report refer only to the sample(s) tested unless otherwise stated. This test report cannot be reproduced, except in full, without prior written permission of the Company. This test report does not assure KOLAS accreditation.

High Channel

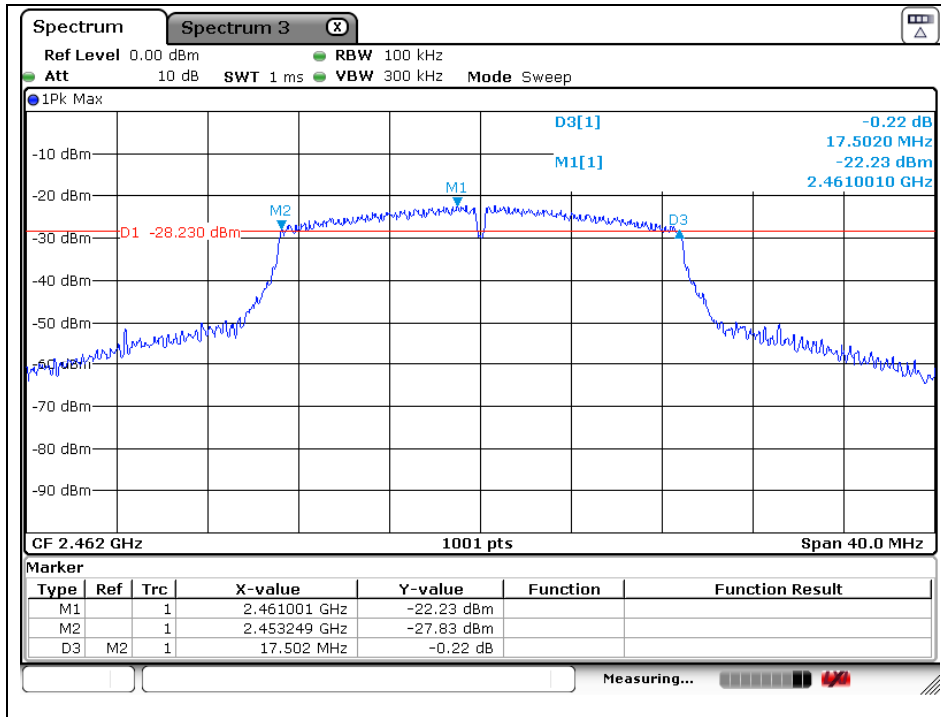

OFDM: 802.11n_HT40

Low Channel

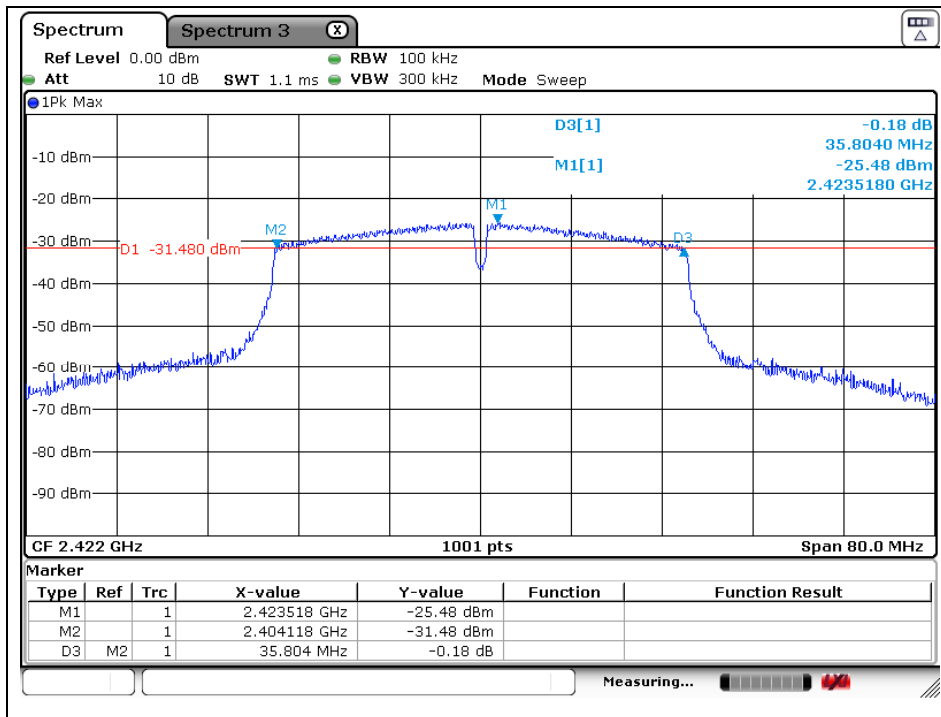

The results shown in this test report refer only to the sample(s) tested unless otherwise stated. This test report cannot be reproduced, except in full, without prior written permission of the Company. This test report does not assure KOLAS accreditation.

Middle Channel

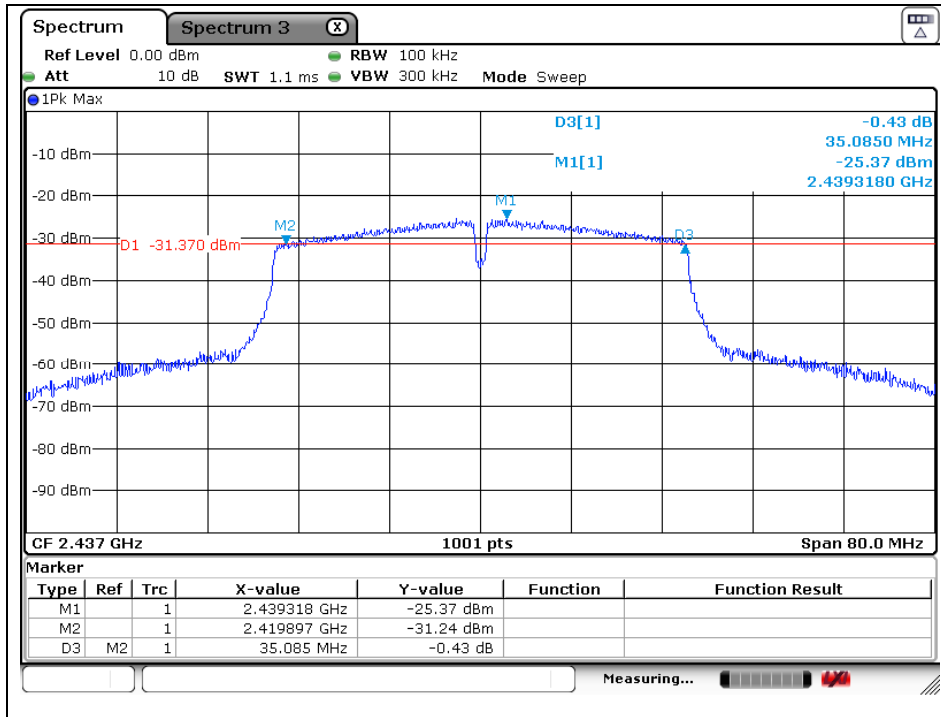

High Channel

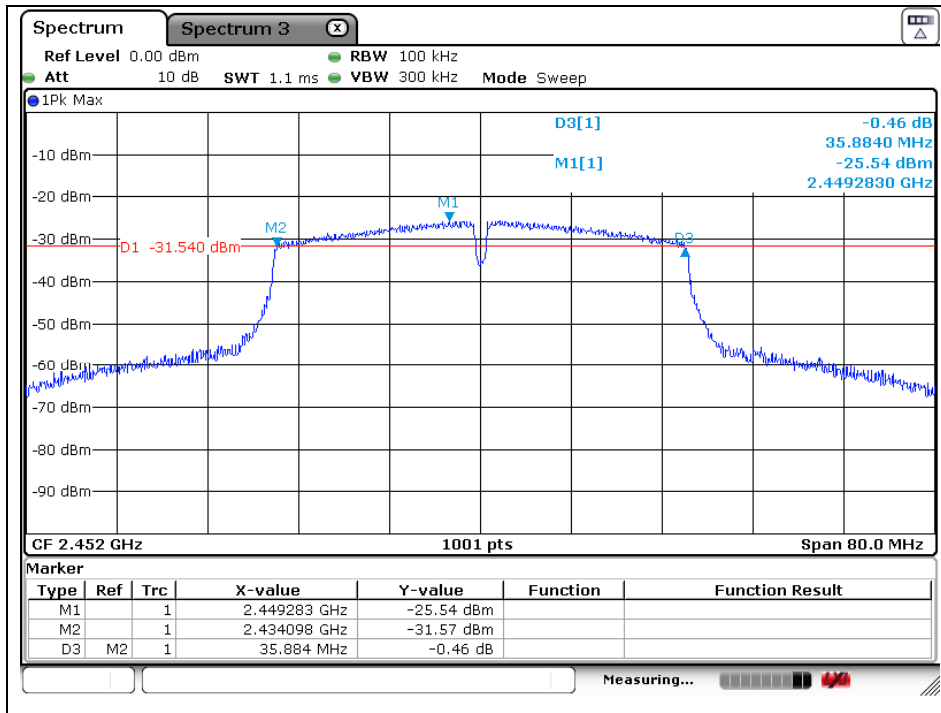

The results shown in this test report refer only to the sample(s) tested unless otherwise stated. This test report cannot be reproduced, except in full, without prior written permission of the Company. This test report does not assure KOLAS accreditation.

4. Maximum Peak Conducted Output Power

4.1. Test Setup

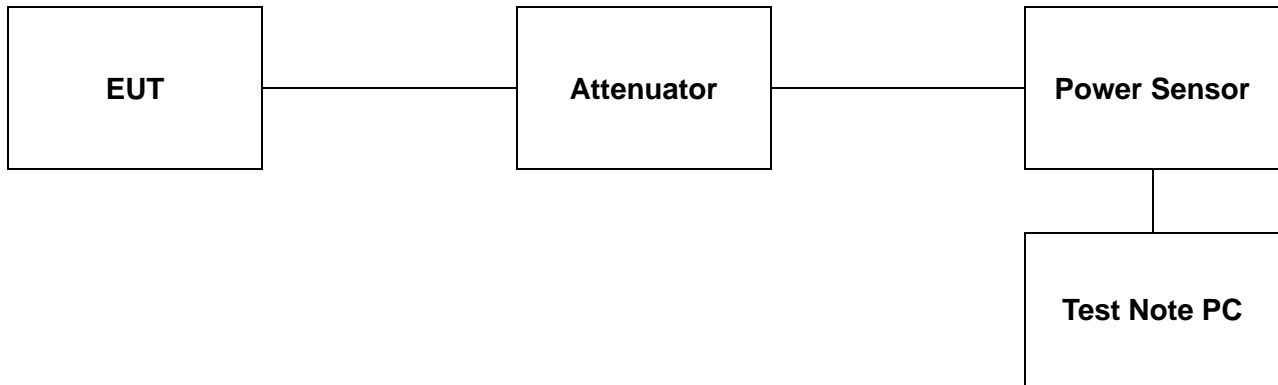

4.2. Limit

§15.247(b)(3), for systems using digital modulation in the 902-928 MHz, 2 400-2 483.5 MHz, and 5 725-5 850 MHz bands : 1 Watt. As an alternative to a peak power measurement, compliance with the one Watt limit can be based on a measurement of the maximum conducted output power. Maximum Conducted Output Power is defined as the total transmit power delivered to all antennas and antenna elements averaged across all symbols in the signaling alphabet when the transmitter is operating at its maximum power control level. Power must be summed across all antennas and antenna elements. The average must not include any time intervals during which the transmitter is off or is transmitting at a reduced power level. If multiple modes of operation are possible (e.g., alternative modulation methods), the maximum conducted output power is the highest total transmit power occurring in any mode.

According to §15.247(b)(4), the conducted output power limit specified in paragraph (b) of this section is based on the use of antennas with directional gains that do not exceed 6 dBi. Except as shown in paragraph (c) of this section, if transmitting antenna of directional gain greater than 6 dBi are used, the conducted output power from the intentional radiator shall be reduced below the stated values in paragraph (b)(1), (b)(2), and (b)(3) of this section, as appropriate, by the amount in dB that the directional gain of the antenna exceeds 6 dBi.

The results shown in this test report refer only to the sample(s) tested unless otherwise stated. This test report cannot be reproduced, except in full, without prior written permission of the Company. This test report does not assure KOLAS accreditation.

4.3. Test Procedure

The test follows section 9.1.3 of KDB 558074 D01 DTS Meas Guidance v04.

- Peak power meter method

-The maximum peak conducted output power can be measured using a broad band peak RF power meter. The power meter shall have a video bandwidth that is greater than or equal to the DTS bandwidth and shall utilize a fast-responding diode detector.

Test program: (S/W name : R&S Power Viewer, Version : 3.2.0)

1. Initially overall offset for attenuator and cable loss is measured per frequency.
2. Measured offset is inserted in test program in advance of measurement for output power.
3. Power for each frequency (channel) of device is investigated as final result.
4. Final result reported on this section from R&S power viewer program includes with several factors and test program shows only final result.

The results shown in this test report refer only to the sample(s) tested unless otherwise stated. This test report cannot be reproduced, except in full, without prior written permission of the Company. This test report does not assure KOLAS accreditation.

SGS Korea Co., Ltd. (Gunpo Laboratory) 4, LS-ro 182beon-gil, Gunpo-si, Gyeonggi-do, Korea, 15807 <http://www.sgsgroup.kr>

RTT5041-19(2017.07.10)(0)

Tel. +82 31 428 5700 / Fax. +82 31 427 2370

A4(210 mm x 297 mm)

4.4. Test Results

Ambient temperature : (23 ± 1) °C
 Relative humidity : 47 % R.H.

| Mode | Channel | Frequency (MHz) | Data Rate | Attenuator + Cable offset (dB) | Peak Power Result (dB m) | Peak Power Limit (dB m) |
|---------------------|---------|-----------------|-----------|--------------------------------|--------------------------|-------------------------|
| DSSS (802.11b) | Low | 2 412 | 1 Mbps | 20.36 | 20.08 | 30 |
| | Middle | 2 437 | | 20.44 | <u>20.16</u> | |
| | High | 2 462 | | 20.57 | 20.11 | |
| OFDM (802.11g) | Low | 2 412 | 6 Mbps | 20.36 | 23.14 | |
| | Middle | 2 437 | | 20.44 | <u>23.17</u> | |
| | High | 2 462 | | 20.57 | 23.06 | |
| OFDM (802.11n_HT20) | Low | 2 412 | MCS0 | 20.36 | 22.28 | |
| | Middle | 2 437 | | 20.44 | <u>22.31</u> | |
| | High | 2 462 | | 20.57 | 22.02 | |
| OFDM (802.11n_HT40) | Low | 2 422 | MCS0 | 20.40 | <u>21.87</u> | |
| | Middle | 2 437 | | 20.44 | 21.57 | |
| | High | 2 452 | | 20.52 | 21.71 | |

Remark;

Attenuator and cable offset was compensated in test program (R&S Power Viewer) before measuring.

The results shown in this test report refer only to the sample(s) tested unless otherwise stated. This test report cannot be reproduced, except in full, without prior written permission of the Company. This test report does not assure KOLAS accreditation.

5. Power Spectral Density

5.1. Test Setup

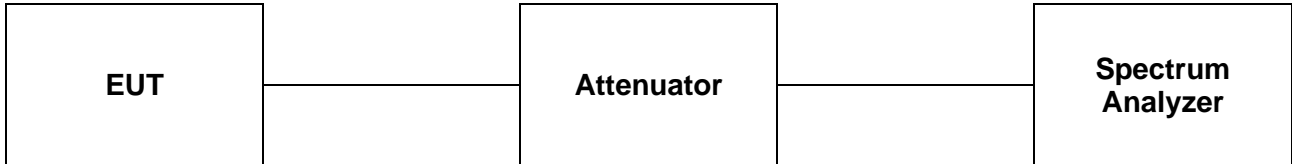

5.2. Limit

§15.247(e) for digitally modulated system, the power spectral density conducted from the intentional radiator to the antenna shall not be greater than 8 dBm in any 3 kHz band during any time interval of continuous transmission. This power spectral density shall be determined in accordance with the provisions of paragraph (b) of this section. The same method of determining the conducted output power shall be used to determine the power spectral density.

5.3. Test Procedure

All data rates and modes were investigated for this test. The full data for the worst case data rate are reported in this section.

The measurements are recorded using the PKPSD measurement procedure in section 10.2 of KDB 558074 D01 DTS Meas Guidance v04.

- This procedure shall be used if maximum peak conducted output power was used to demonstrate compliance, and is optional if the maximum conducted (average) output power was used to demonstrate compliance.

1. Set analyzer center frequency to DTS channel center frequency.
2. Set the span to $1.5 \times$ DTS bandwidth.
3. Set the RBW to : $3 \text{ kHz} \leq \text{RBW} \leq 100 \text{ kHz}$.
4. Set the VBW $\geq 3 \times$ RBW.
5. Detector = Peak.
6. Sweep time = auto couple.
7. Trace mode = max hold.
8. Allow trace to fully stabilize.
9. Use the peak marker function to determine the maximum amplitude level within the RBW.
10. If measured value exceeds limit, reduce RBW (no less than 3 kHz) and repeat.

The results shown in this test report refer only to the sample(s) tested unless otherwise stated. This test report cannot be reproduced, except in full, without prior written permission of the Company. This test report does not assure KOLAS accreditation.

5.4. Test Results

Ambient temperature : (23 ± 1) °C
 Relative humidity : 47 % R.H.

| Operation Mode | Data Rate | Channel | Frequency (MHz) | Measured PSD (dB m) | Maximum Limit (dB m) |
|---------------------|-----------|---------|-----------------|---------------------|----------------------|
| DSSS (802.11b) | 1 Mbps | Low | 2 412 | -5.16 | 8 |
| | | Middle | 2 437 | -4.70 | |
| | | High | 2 462 | -4.52 | |
| OFDM (802.11g) | 6 Mbps | Low | 2 412 | -9.23 | |
| | | Middle | 2 437 | -9.34 | |
| | | High | 2 462 | -8.18 | |
| OFDM (802.11n_HT20) | MCS0 | Low | 2 412 | -10.63 | |
| | | Middle | 2 437 | -11.47 | |
| | | High | 2 462 | -11.97 | |
| OFDM (802.11n_HT40) | MCS0 | Low | 2 422 | -15.75 | |
| | | Middle | 2 437 | -15.12 | |
| | | High | 2 452 | -15.56 | |

The results shown in this test report refer only to the sample(s) tested unless otherwise stated. This test report cannot be reproduced, except in full, without prior written permission of the Company. This test report does not assure KOLAS accreditation.

DSSS: 802.11b

Low Channel

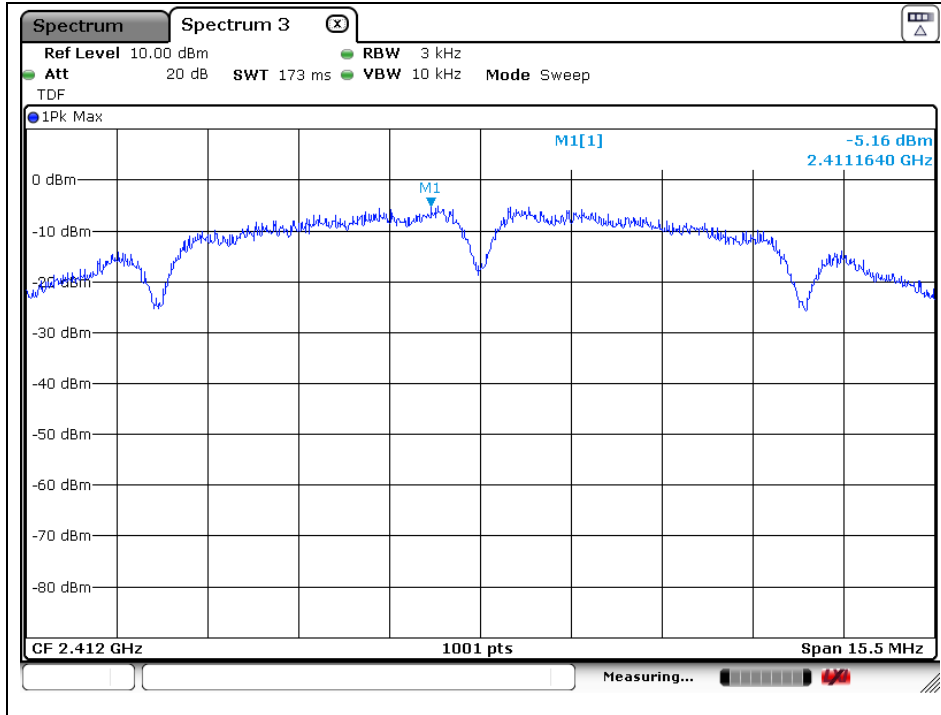

Middle Channel

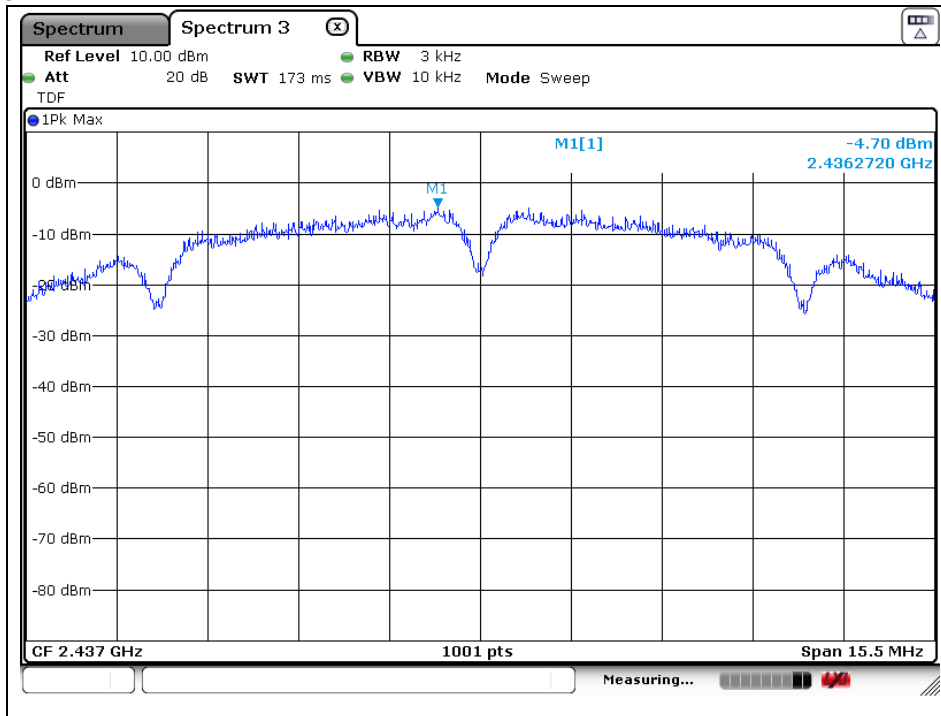

The results shown in this test report refer only to the sample(s) tested unless otherwise stated. This test report cannot be reproduced, except in full, without prior written permission of the Company. This test report does not assure KOLAS accreditation.

High Channel

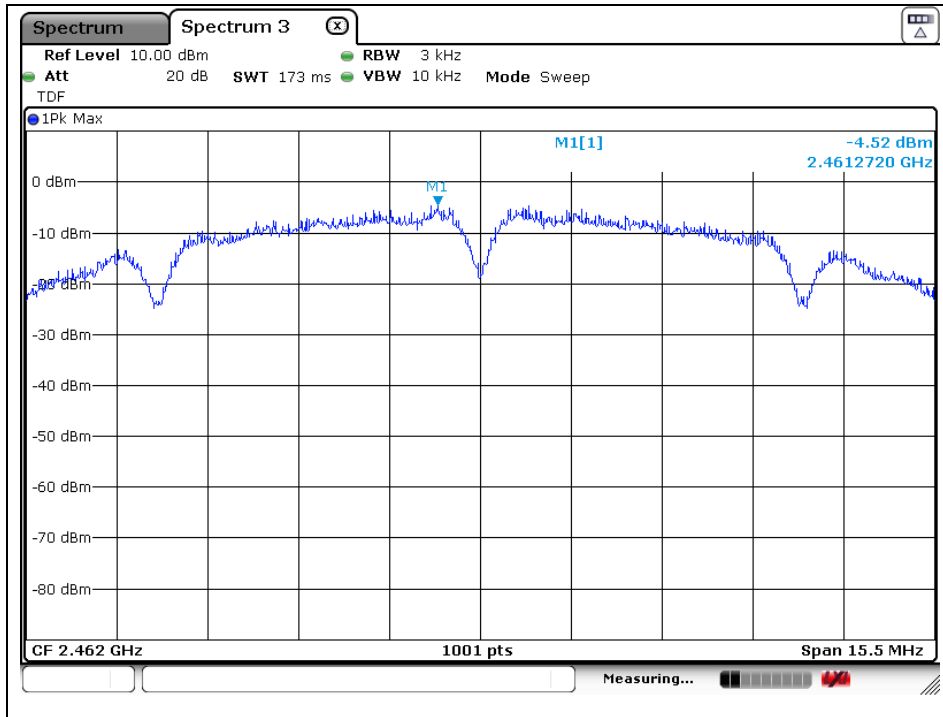

OFDM: 802.11g

Low Channel

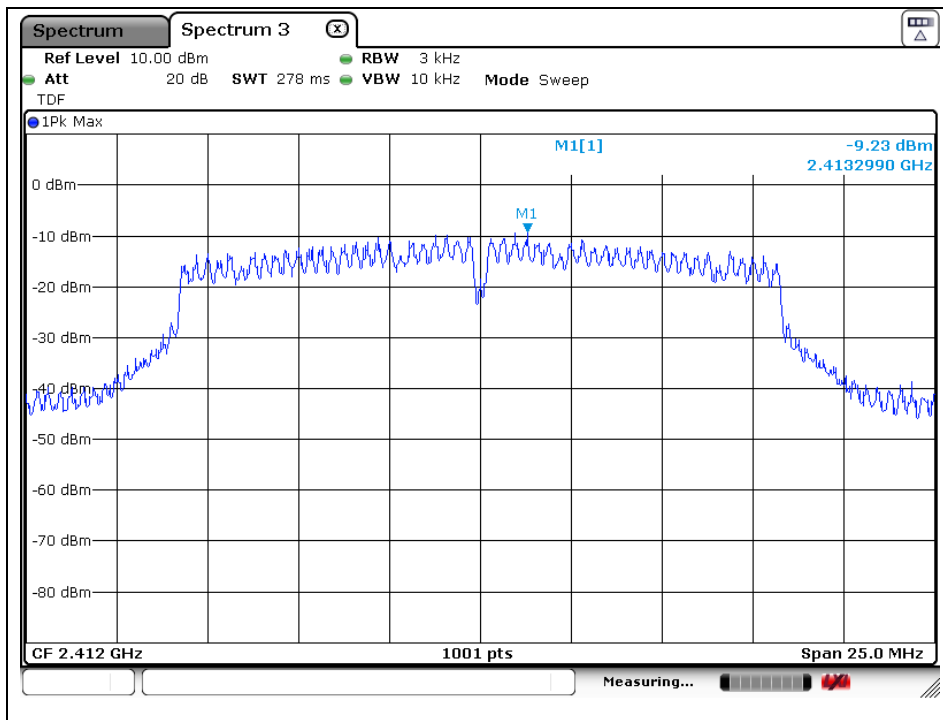

The results shown in this test report refer only to the sample(s) tested unless otherwise stated. This test report cannot be reproduced, except in full, without prior written permission of the Company. This test report does not assure KOLAS accreditation.

Middle Channel

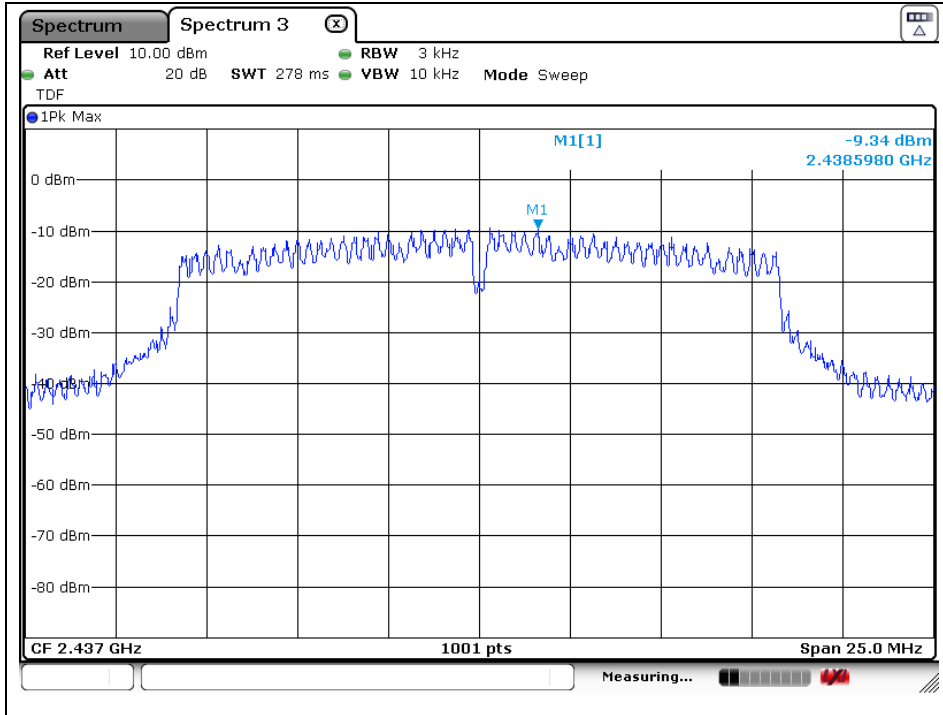

High Channel

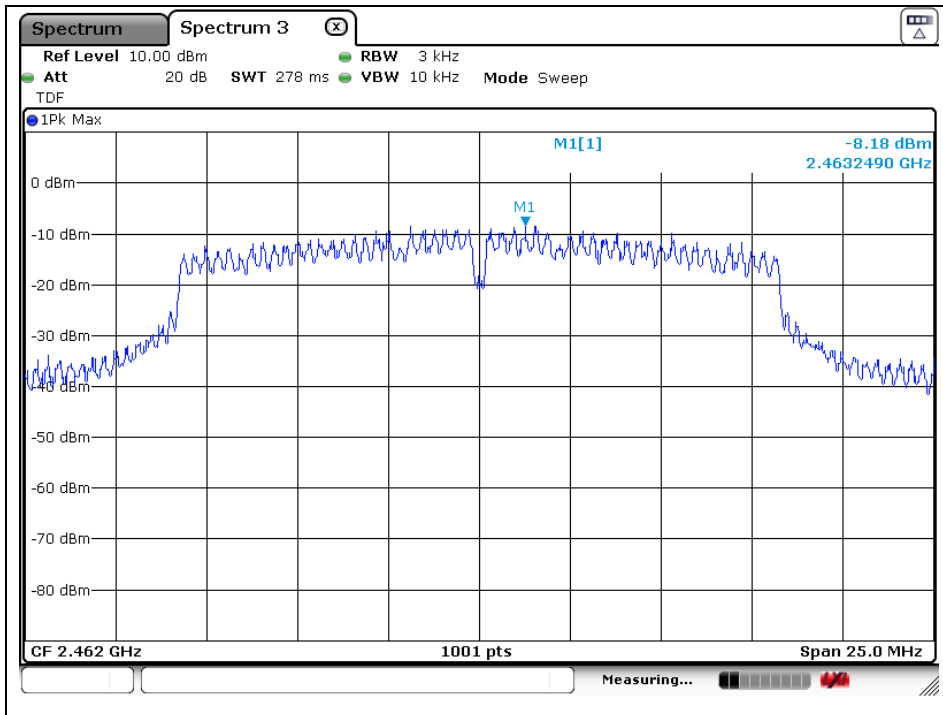

The results shown in this test report refer only to the sample(s) tested unless otherwise stated. This test report cannot be reproduced, except in full, without prior written permission of the Company. This test report does not assure KOLAS accreditation.

OFDM: 802.11n_HT20

Low Channel

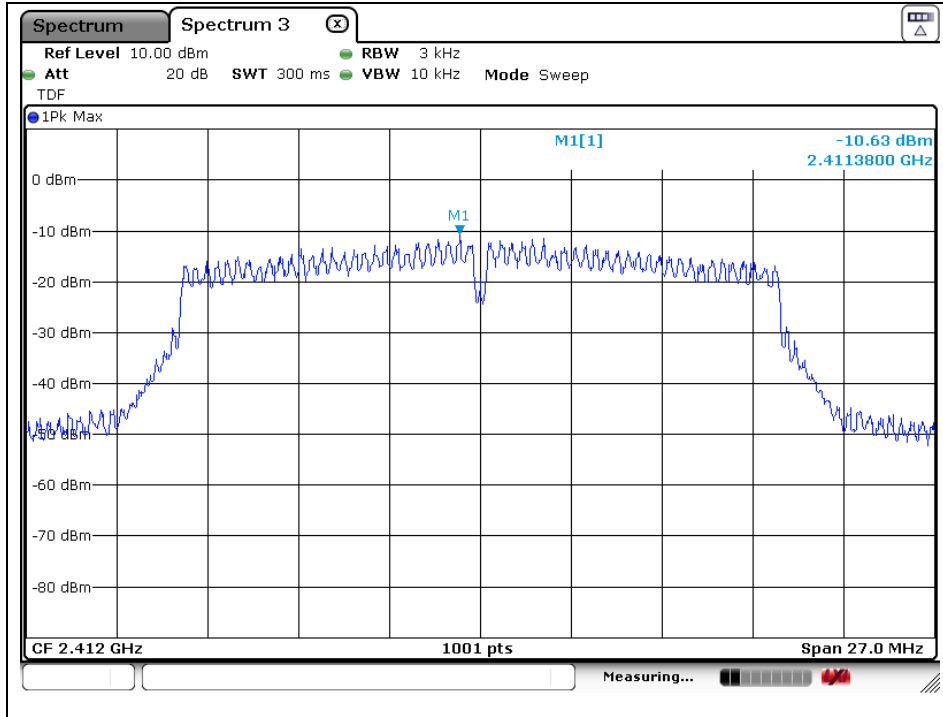

Middle Channel

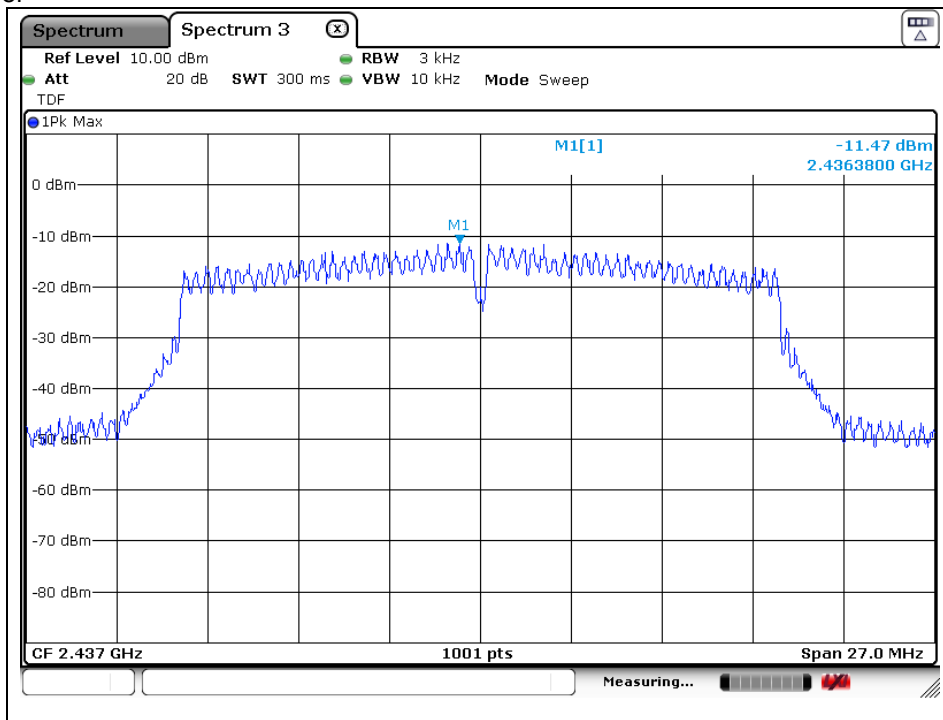

The results shown in this test report refer only to the sample(s) tested unless otherwise stated. This test report cannot be reproduced, except in full, without prior written permission of the Company. This test report does not assure KOLAS accreditation.

High Channel

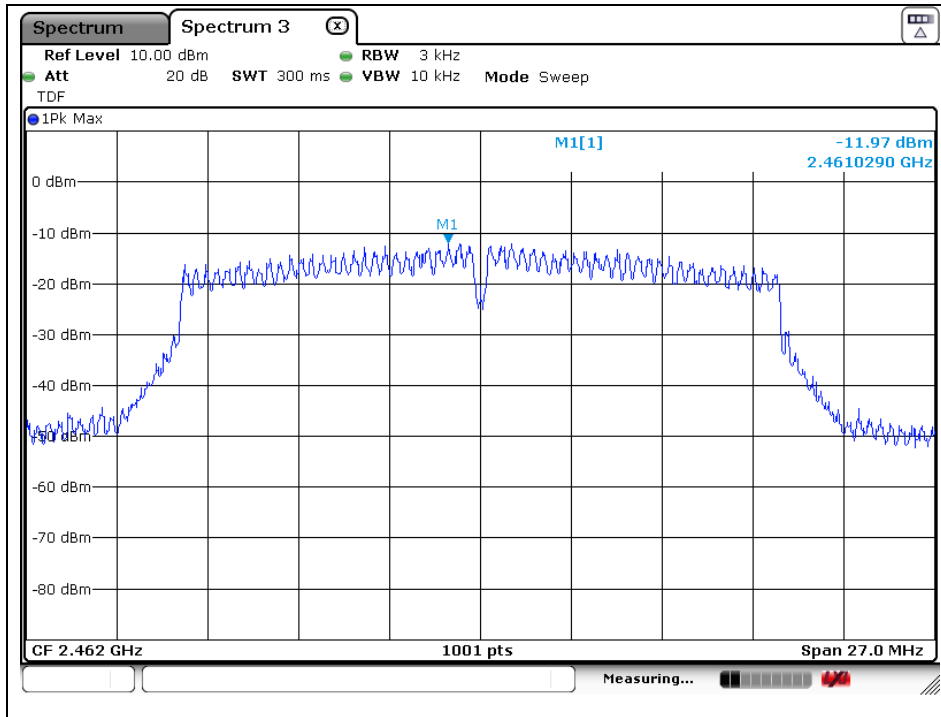

OFDM: 802.11n_HT40

Low Channel

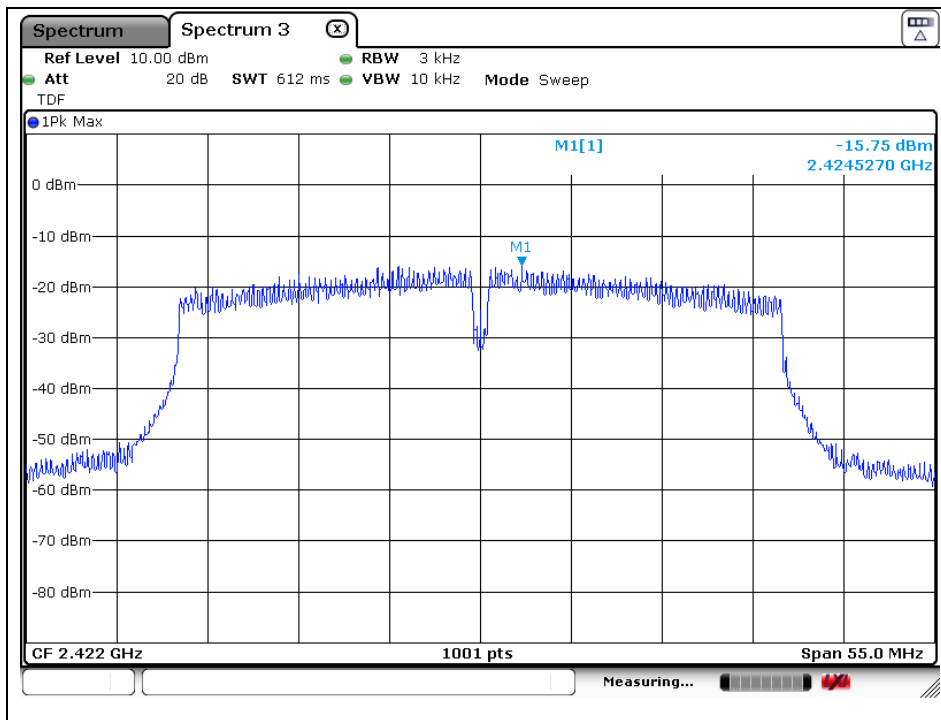

The results shown in this test report refer only to the sample(s) tested unless otherwise stated. This test report cannot be reproduced, except in full, without prior written permission of the Company. This test report does not assure KOLAS accreditation.

Middle Channel

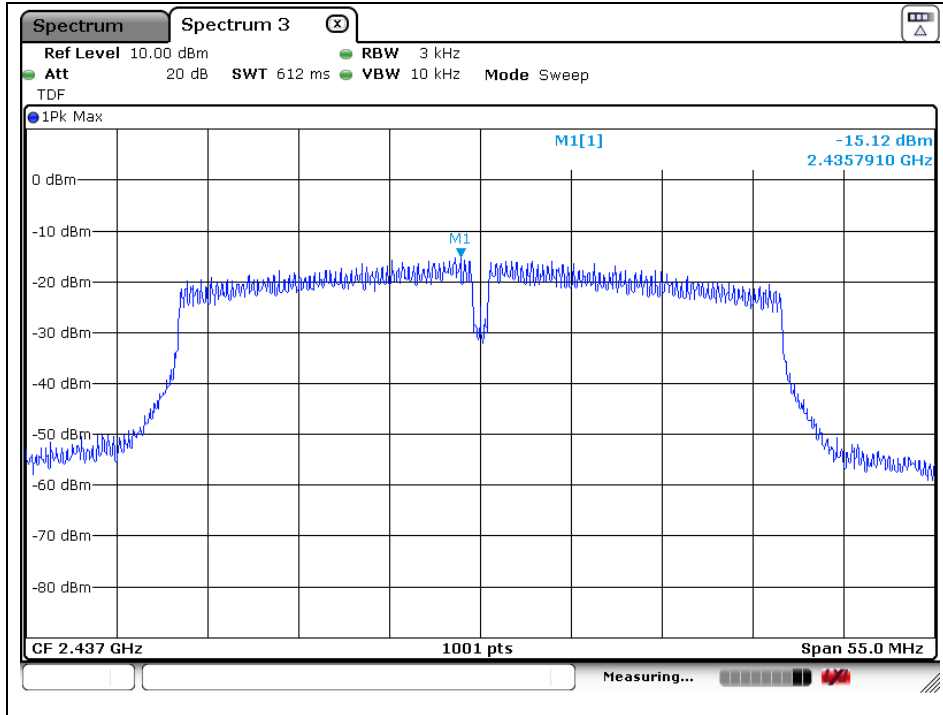

High Channel

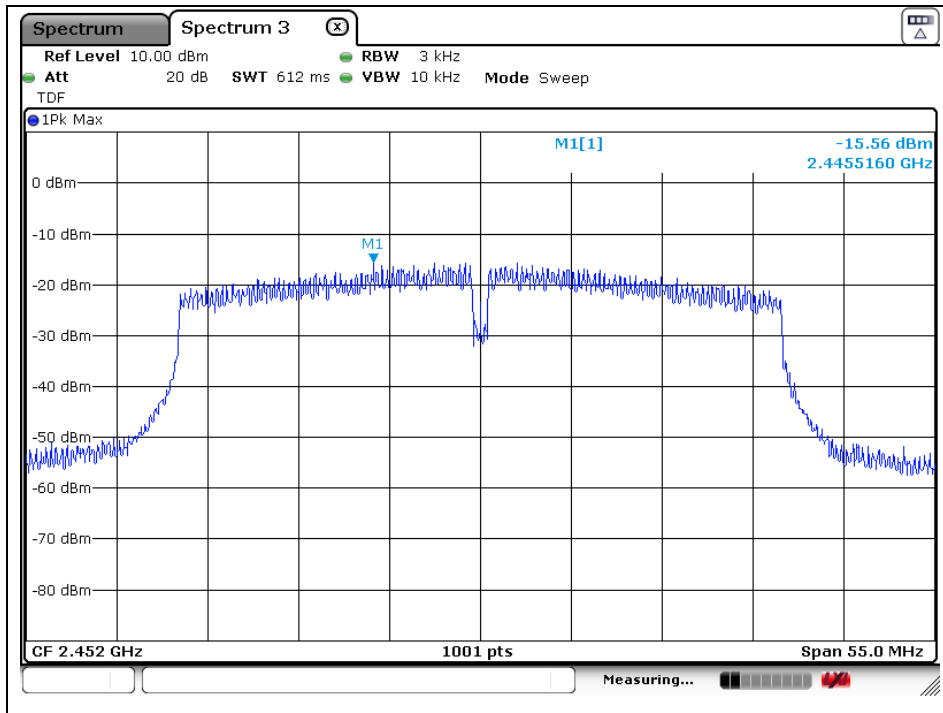

The results shown in this test report refer only to the sample(s) tested unless otherwise stated. This test report cannot be reproduced, except in full, without prior written permission of the Company. This test report does not assure KOLAS accreditation.

6. AC Power Line Conducted Emission

6.1. Test Setup

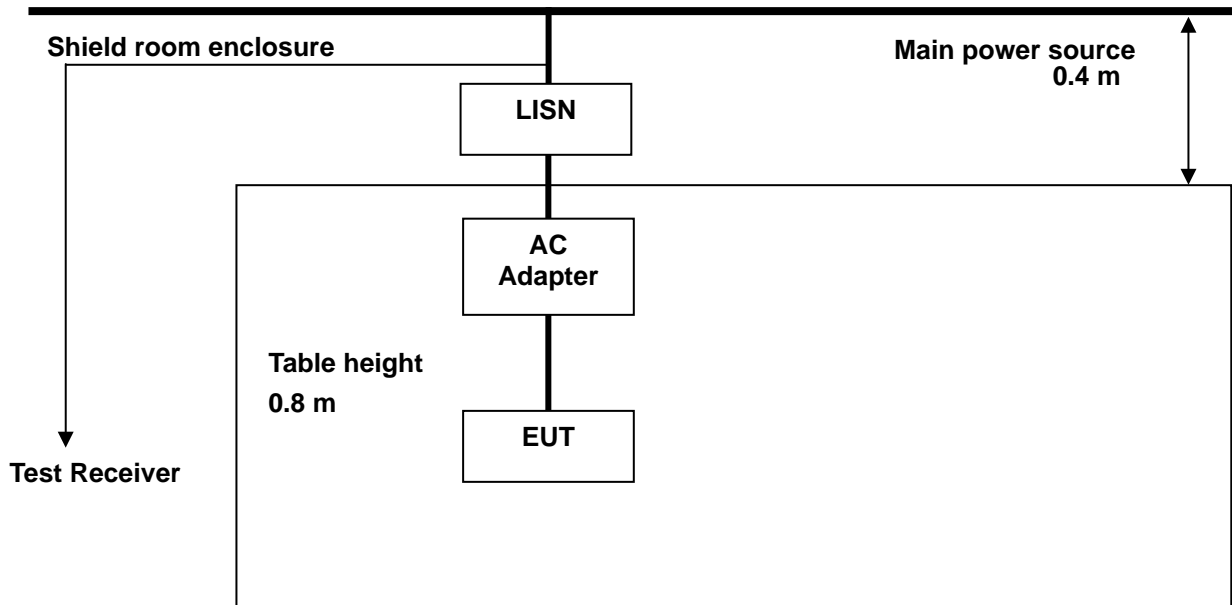

6.2. Limit

According to §15.207(a) for an intentional radiator that is designed to be connected to the public utility (AC) power line, the radio frequency voltage that is conducted back onto the AC power line on any frequency or frequencies, within the band 150 kHz to 30 MHz, shall not exceed the limits in the following table, as measured using a 50 μ H / 50 ohm line impedance stabilization network (LISN).

Compliance with the provision of this paragraph shall be on the measurement of the radio frequency voltage between each power line and ground at the power terminal. The lower value applies at the boundary between the frequency ranges.

| Frequency of Emission (MHz) | Conducted limit (dB μ V) | |
|-----------------------------|------------------------------|----------|
| | Quasi-peak | Average |
| 0.15 – 0.50 | 66 - 56* | 56 - 46* |
| 0.50 – 5.00 | 56 | 46 |
| 5.00 – 30.0 | 60 | 50 |

* Decreases with the logarithm of the frequency.

The results shown in this test report refer only to the sample(s) tested unless otherwise stated. This test report cannot be reproduced, except in full, without prior written permission of the Company. This test report does not assure KOLAS accreditation.

SGS Korea Co., Ltd. (Gunpo Laboratory) 4, LS-ro 182beon-gil, Gunpo-si, Gyeonggi-do, Korea, 15807 <http://www.sgsgroup.kr>

RTT5041-19(2017.07.10)(0)

Tel. +82 31 428 5700 / Fax. +82 31 427 2370

A4(210 mm x 297 mm)

6.3. Test Procedures

AC conducted emissions from the EUT were measured according to the dictates of ANSI C63.10-2013

1. The test procedure is performed in a 6.5 m × 3.5 m × 3.5 m (L × W × H) shielded room. The EUT along with its peripherals were placed on a 1.0 m (W) × 1.5 m (L) and 0.8 m in height wooden table and the EUT was adjusted to maintain a 0.4 meter space from a vertical reference plane.
2. The EUT was connected to power mains through a line impedance stabilization network (LISN) which provides 50 ohm coupling impedance for measuring instrument and the chassis ground was bounded to the horizontal ground plane of shielded room.
3. All peripherals were connected to the second LISN and the chassis ground also bounded to the horizontal ground plane of shielded room.
4. The excess power cable between the EUT and the LISN was bundled. The power cables of peripherals were unbundled. All connecting cables of EUT and peripherals were moved to find the maximum emission.

The results shown in this test report refer only to the sample(s) tested unless otherwise stated. This test report cannot be reproduced, except in full, without prior written permission of the Company. This test report does not assure KOLAS accreditation.

SGS Korea Co., Ltd. (Gunpo Laboratory) 4, LS-ro 182beon-gil, Gunpo-si, Gyeonggi-do, Korea, 15807 <http://www.sgsgroup.kr>

RTT5041-19(2017.07.10)(0)

Tel. +82 31 428 5700 / Fax. +82 31 427 2370

A4(210 mm × 297 mm)

6.4. Test Results

The following table shows the highest levels of conducted emissions on both phase of Hot and Neutral line.

Ambient temperature : (24 ± 1) °C
 Relative humidity : 47 % R.H.
 Frequency range : 0.15 MHz – 30 MHz
 Measured Bandwidth : 9 kHz

| FREQ. (MHz) | LEVEL (dB μ V) | | LINE | LIMIT (dB μ V) | | MARGIN (dB) | |
|----------------|--------------------|---------|------|--------------------|---------|-------------|---------|
| | Q-Peak | Average | | Q-Peak | Average | Q-Peak | Average |
| 0.61 | 34.40 | 20.70 | N | 56.00 | 46.00 | 21.60 | 25.30 |
| 0.79 | 27.40 | 20.20 | N | 56.00 | 46.00 | 28.60 | 25.80 |
| 1.00 | 29.80 | 14.50 | N | 56.00 | 46.00 | 26.20 | 31.50 |
| 1.41 | 25.50 | 16.40 | N | 56.00 | 46.00 | 30.50 | 29.60 |
| 9.96 | 31.90 | 17.10 | N | 60.00 | 50.00 | 28.10 | 32.90 |
| 21.49 | 27.60 | 21.10 | N | 60.00 | 50.00 | 32.40 | 28.90 |
| 0.28 | 30.70 | 21.40 | H | 60.82 | 50.82 | 30.12 | 29.42 |
| 0.41 | 28.00 | 13.90 | H | 57.65 | 47.65 | 29.65 | 33.75 |
| 0.44 | 27.80 | 16.90 | H | 57.06 | 47.06 | 29.26 | 30.16 |
| 0.67 | 26.80 | 15.80 | H | 56.00 | 46.00 | 29.20 | 30.20 |
| 1.40 | 15.80 | 8.90 | H | 56.00 | 46.00 | 40.20 | 37.10 |
| 26.81 | 24.50 | 17.50 | H | 60.00 | 50.00 | 35.50 | 32.50 |

Note ;

- Line (H): Hot, Line (N): Neutral.
- All modes of operation were investigated and the worst-case emissions were reported using 11b / 1Mbps / Low channel.
- The limit for Class B device(s) from 150 kHz to 30 MHz are specified in Section of the Title 47 CFR.
- Traces shown in plot were made by using a peak detector and average detector.
- Deviations to the Specifications: None.

The results shown in this test report refer only to the sample(s) tested unless otherwise stated. This test report cannot be reproduced, except in full, without prior written permission of the Company. This test report does not assure KOLAS accreditation.

Test mode: (Neutral)

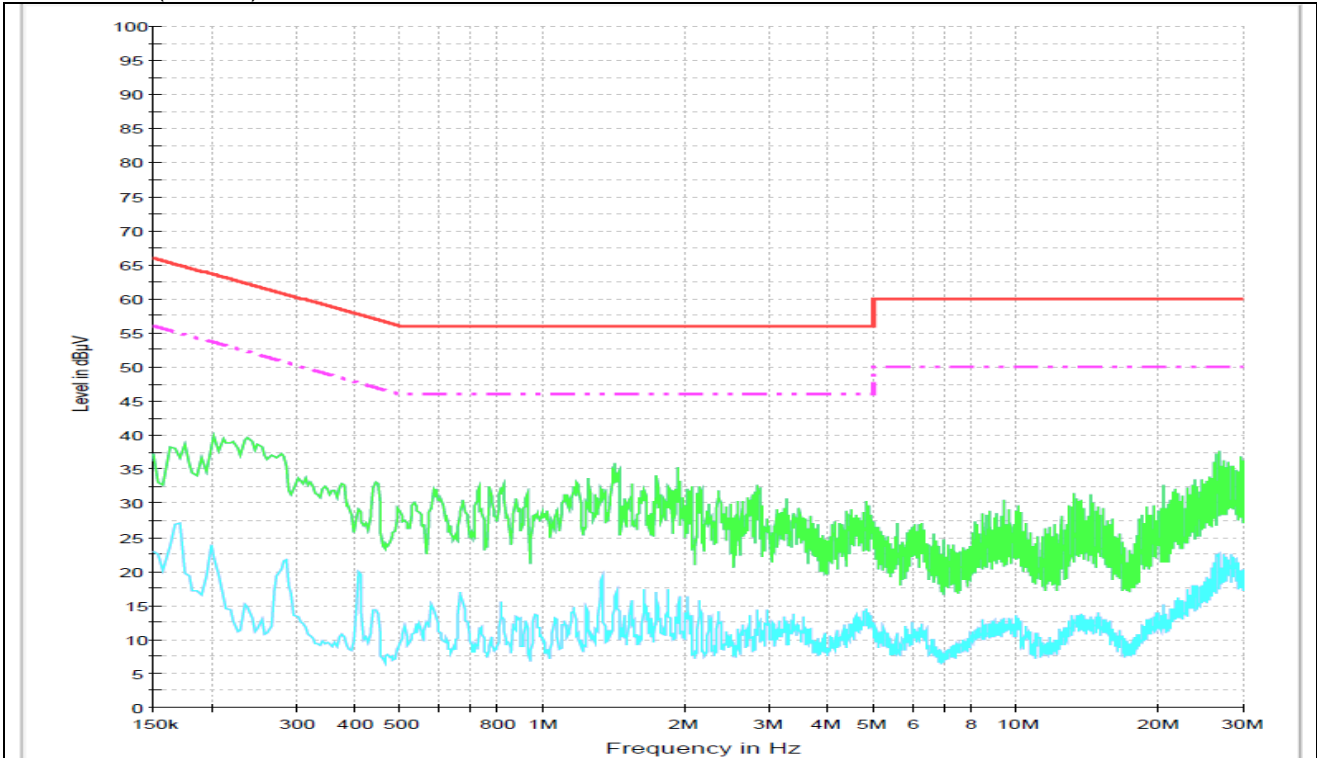

Test mode: (Hot)

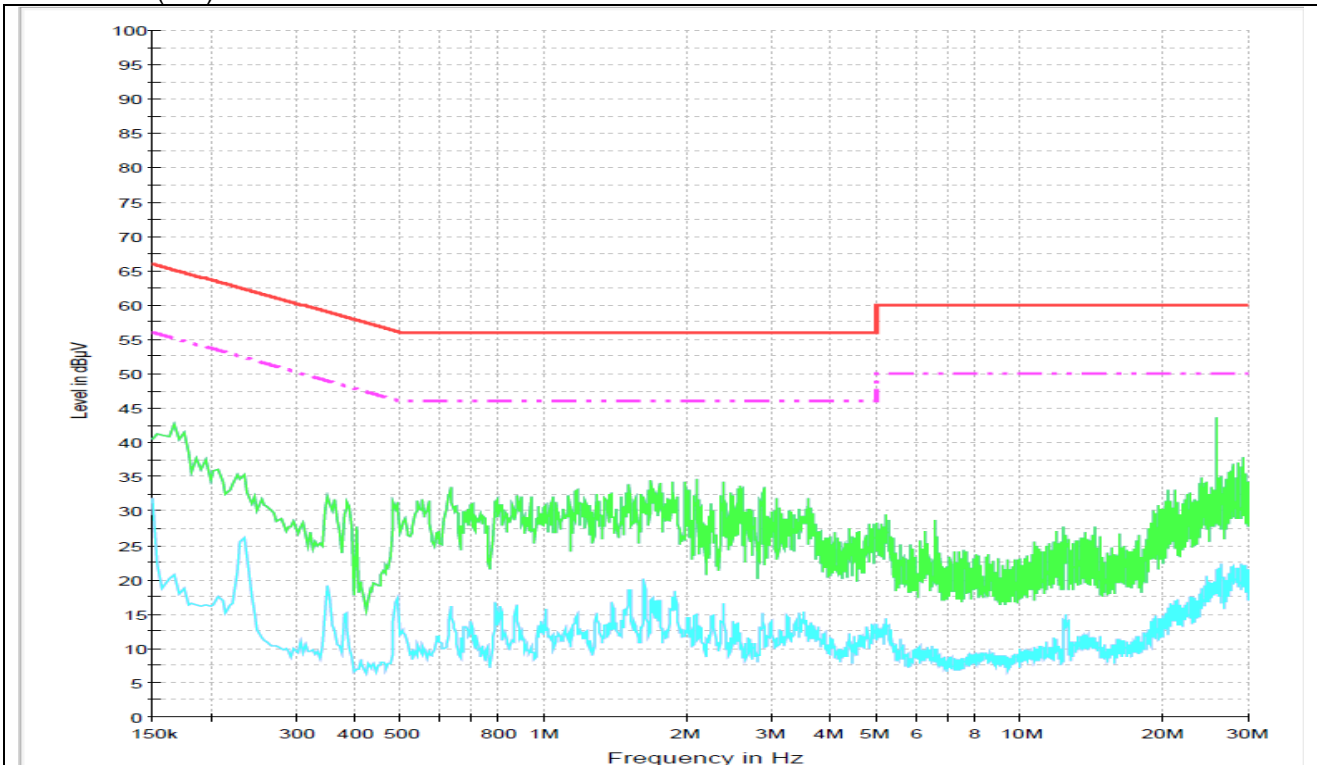

The results shown in this test report refer only to the sample(s) tested unless otherwise stated. This test report cannot be reproduced, except in full, without prior written permission of the Company. This test report does not assure KOLAS accreditation.

7. Antenna Requirement

7.1. Standard Applicable

For intentional device, according to FCC 47 CFR Section §15.203, an intentional radiator shall be designed to ensure that no antenna other than that furnished by the responsible party shall be used with the device. And according to FCC 47 CFR Section §15.247 (b) if transmitting antennas of directional gain greater than 6 dB i are used, the power shall be reduced by the amount in dB that the gain of the antenna exceeds 6 dB i.

7.2. Antenna Connected Construction

Antenna used in this product is PCB pattern type with gain of 1.15 dB i.

- End of the Test Report -

The results shown in this test report refer only to the sample(s) tested unless otherwise stated. This test report cannot be reproduced, except in full, without prior written permission of the Company. This test report does not assure KOLAS accreditation.

SGS Korea Co., Ltd. (Gunpo Laboratory) 4, LS-ro 182beon-gil, Gunpo-si, Gyeonggi-do, Korea, 15807 <http://www.sgsgroup.kr>

RTT5041-19(2017.07.10)(0)

Tel. +82 31 428 5700 / Fax. +82 31 427 2370

A4(210 mm x 297 mm)