

User Manual

PRODUCT NAME : Single Band Wi-Fi + MCU Module

MODEL NAME : LCW-003

LGIT NAME : TWFB-E351D

Table of Contents

No	Description	Page
1	Features	2
2	Block Diagram	2
3	Storage conditions	3
4	Operating Test Conditions	3
5	Electrical Characteristics	4
6	Pin Description	7
7	Outline Drawing	8
8	Packing Information	9
9	Warning Statement	10

1. Features

TWFB-E301D is the module for IEEE 802.11b/g/n wireless LAN + MCU.

TWFB-E301D is based on Qualcomm QCA4010 solution.

- IEEE 802.11 b/g/n HT20 single band WLAN Infrastructure
- Size : 32mm x 48mm x 9.35 mm
- Auto-calibration(RF, Crystal)
- Data rates up to 65Mbps PHY rate
- UART interface
- Integrated IPv4/IPv6 TCP/IP stack
- Integrated Network services such as HTTP, DNS, FTP
- Security : WFA, WPA, WPA2, WEP, WAPI, TKIP
- Application : Home Appliance

2. Block Diagram

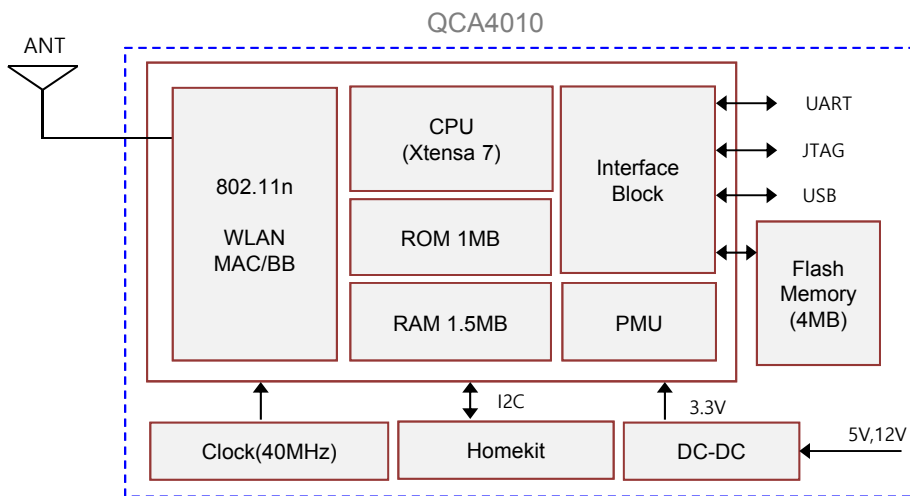

3. Storage conditions

Parameter	Min	Max	Unit
Storage Temperature	-20	+80	°C
Storage Humidity (@ 40°C)	-	90	%

Caution : The specifications above the Table define levels at which permanent damage to the device can occur. Function operation is not guaranteed under these conditions. Operating at absolute maximum conditions for extend periods can adversely affect the long-term reliability of the device.

- Other conditions
 - 1) Do not use or store modules in the corrosive atmosphere, especially where chloride gas, sulfide gas, acid, alkali, salt or the like are contained.
Also, avoid exposure to moisture.
 - 2) Store the modules where the temperature and relative humidity do not exceed 5 to 40°C and 20 to 60%.
 - 3) Assemble the modules within 6 months.
Check the soldering ability in case of 6 months over.

4. Operating Test Conditions

Parameter	Min	Typ	Max	Unit
Operating Temperature	0	-	+60	°C
Operating Humidity (40°C)	-	-	85	%
Supply Voltage	4.5	5.0	5.5	Vdc
	10.8	12	13.2	

5. Electrical Characteristics

5-1. RF Characteristics for IEEE802.11b (11Mbps mode unless otherwise specified)

Items	Contents			
Specification	IEEE802.11b			
Mode	DSSS/CCK			
Channel frequency	2400 ~ 2483 MHz			
Data rate	1,2,5.5,11Mbps			
TX Characteristics	Min.	Typ.	Max.	Unit
Power Level	13	17	21	dBm
Spectrum Mask				
1 st side lobes (to fc \pm 11MHz)	-	-43	-30	dBr
2 nd side lobes (to fc \pm 22MHz)	-	-58	-50	dBr
Modulation Accuracy (EVM)	-	30	35	%
Power On/Off ramp	-	0.5	2.0	Usec
Freq. Tolerance	-25	-	25	ppm
Chip Clock Freq. Tolerance	-25	-	25	ppm
RX Characteristics	Min.	Typ.	Max.	Unit
Minimum Input Level Sens. (FER \leq 8%)		-88	-76	dBm
Maximum Input Level (FER \leq 8%)	-10	-	-	dBm

* Normal Condition : 25°C, VDD=5V.

* RF characteristics is board limit. It can differ according to standards

5-2. RF Characteristics for IEEE802.11g (54Mbps mode unless otherwise specified)

Items	Contents			
Specification	IEEE802.11g			
Mode	OFDM			
Channel frequency	2400 ~ 2483 MHz			
Data rate	6,9,12,18,24,36,48,54Mbps			
TX Characteristics	Min.	Typ.	Max.	Unit
Power Level	10	14	18	dBm
Spectrum Mask				
at $f_c \pm 11\text{MHz}$	-	-32	-20	dBr
at $f_c \pm 20\text{MHz}$	-	-43	-28	dBr
at $f_c \geq \pm 30\text{MHz}$	-	-48	-40	dBr
Constellation Error (EVM)	-	-32	-25	dB
Freq. Tolerance	-20	-	20	ppm
Chip Clock Freq. Tolerance	-20	-	20	ppm
RX Characteristics	Min.	Typ.	Max.	Unit
Minimum Input Level Sens. (PER \leq 10%)	-	-73	-65	dBm
Maximum Input Level (PER \leq 10%)	-20	-	-	dBm

* Normal Condition : 25°C, VDD=5V.

* RF characteristics is board limit. It can differ according to standards

5-3. RF Characteristics for IEEE802.11gn (MCS7 mode unless otherwise specified)

Items	Contents			
Specification	IEEE802.11n – 2.4GHz			
Mode	OFDM			
Channel frequency	2400 ~ 2483 MHz			
Data rate	6.5,13,19.5,26,39,52,58.5,65Mbps			
TX Characteristics	Min.	Typ.	Max.	Unit
Power Level (HT20 : MCS7)	9	13	17	dBm
Spectrum Mask (HT20)				
at $f_c \pm 11\text{MHz}$	-	-32	-20	dBr
at $f_c \pm 20\text{MHz}$	-	-35	-28	dBr
at $f_c \pm 30\text{MHz}$	-	-45	-40	dBr
Constellation Error (EVM)	-	-32	-28	dB
Freq. Tolerance	-20	-	20	ppm
Chip Clock Freq. Tolerance	-20	-	20	ppm
RX Characteristics	Min.	Typ.	Max.	Unit
Minimum Input Level Sens. (HT20, PER $\leq 10\%$)	-	-68	-64	dBm
Maximum Input Level (PER $\leq 10\%$)	-20	-	-	dBm

* Normal Condition : 25°C, VDD=5V.

* RF characteristics is board limit. It can differ according to standards

6. Pin Description

Pin No.	Pin Name	I/O	Pin Description
1	VDD	I	VDD 5.0V, 12V \pm 5%
2	UART Rx	I	UART Communication signal line
3	UART Tx	O	UART Communication signal line
4	GND	-	GND

< TOP View >

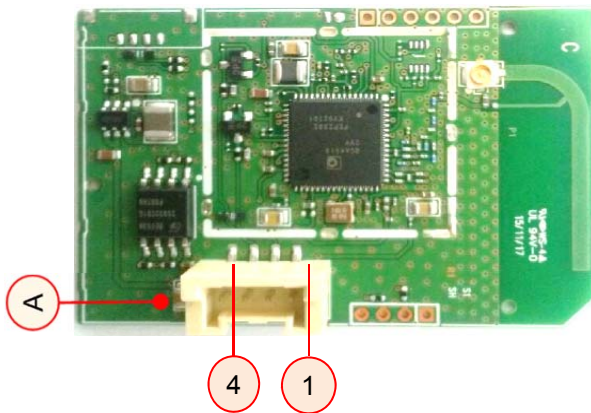

< Bottom View >

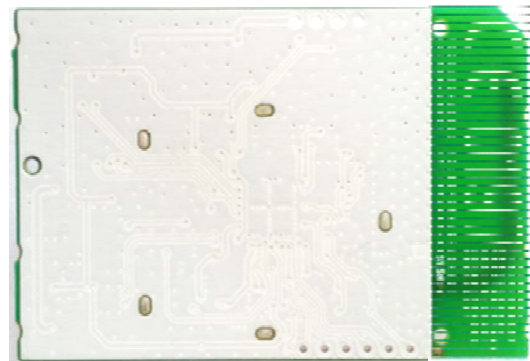

Note.

- 1) Recommend a Module install sequence for prevent UART device failure
 - Supply 5.0V, 12V power
 - Connect to data signal (UART Tx, UART Rx)
- 2) Connector: 4Pin SMD Connector (A)

7. Outline Drawing

Copyright © 2015 by LG Innotek, Co., Ltd. All rights reserved.
 No part of this document may be reproduced, stored in a storage device or retrieval system,
 or transmitted in any form or by any means, whether electronic, mechanical, photocopying,
 recording, or otherwise, without the prior written permission of LG Innotek, Co., Ltd.

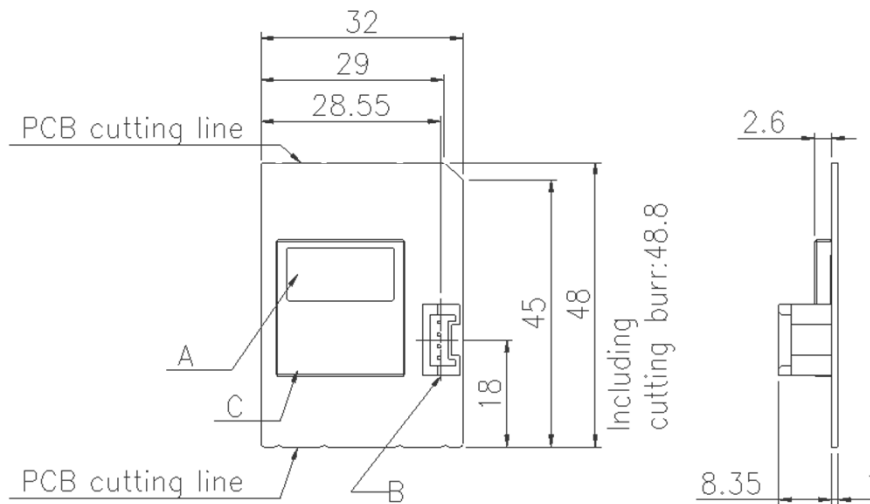

Out line dimensions do not contains coating thickness.

Notes

1. General tolerance : ± 0.2
2. As long as it does not affect performance of the product,
 a appearance can be changed without a prior notice.

C	Shield can	S-tin, 0.3t	
B	Connector	Yeonho SMW200-4H	
A	Label		

CHANGES	NO	PART NAME	DESCRIPTION	REMARK
△				
△				
△				
△				
△				

 THIRD ANGLE PROJECT	SCALE	UNIT	DRAWN	TITLE
	1/1	mm	Sep. 08. 2015 Hyunsung Guk	OUTLINE DRAWING
			CHECKED	MODEL
		APPROVED		DWG ID
		Sep. 08. 2015 Chongsung Kim		

8. Packing Information

-Weight of unit product : 6.9±0.5g
 -Packing capacity : 120ea/tray

-Stack 5 trays with zigzag direction.
 -Stack a empty tray on the top

-Packing capacity : 600ea/inner box
 -Packing weigh : 5.6±0.5kg

-Put the inner box to VCI film.

-Packing capacity : 1200ea/carton box
 -Packing weight : : 11.8±1kg

-Packing capacity : 30 carton boxes/Pallet
 -Packing weight : 364±10kg/Pallet

Dimensions for inner box: 121.5, 512, 37.5
 Dimensions for carton box: 248, 517, 380
 Dimensions for shipping box: 120, 1100, 1200

Labels: ROHS Marking, Barcode Label, VCI Film, Carton Box, Shipping Box, Cap box, Pallet

DIMENSIONAL TOLERANCE	GRADE	UNIT
- 6 Under	△	mm
6 ~ 18 Under	△	mm
18 ~ 30 Under	△	mm
30 ~ 50 Under	△	mm
50 or more	△	mm

DATE	ISSUE	NO	ZONE	UNLESS OTHERWISE SPECIFIED

NO	PART NUMBER	PART NAME	REMARK

SCALE	UNIT	DRAWN	CHECKED	MODEL
1:1	mm	Hyung Guk		TMRB-E301D-F

APPROVED: 2015.09.07
 DWG ID: DRW0000067106

9. Warning Statement

<FCC Warning Statements>

FCC Part 15.19 Statements:

This device complies with Part 15 of the FCC Rules. Operation is subject to the following two conditions: (1) this device may not cause harmful interference, and (2) this device must accept any interference received, including interference that may cause undesired operation.

FCC Part 15.105 statement

This equipment has been tested and found to comply with the limits for a Class B digital device, pursuant to part 15 of the FCC Rules.

These limits are designed to provide reasonable protection against harmful interference in a residential installation. This equipment generates, uses and can radiate radio frequency energy and, if not installed and used in accordance with the instructions, may cause harmful interference to radio communications.

However, there is no guarantee that interference will not occur in a particular installation. If this equipment does cause harmful interference to radio or television reception, which can be determined by turning the equipment off and on, the user is encouraged to try to correct the interference by one or more of the following measures:

- Reorient or relocate the receiving antenna.
- Increase the separation between the equipment and receiver.
- Connect the equipment into an outlet on a circuit different from that to which the receiver is connected.
- Consult the dealer or an experienced radio/TV technician for help.

FCC Part 15.21 statement

Any changes or modifications not expressly approved by the party responsible for compliance could void the user's authority to operate this equipment.

9. Warning Statement

RF Exposure Statement

The antenna(s) must be installed such that a minimum separation distance of at least 20 cm is maintained between the radiator (antenna) and all persons at all times. This device must not be co-located or operating in conjunction with any other antenna or transmitter.

End Product Labeling

The module is labeled with its own FCC ID and IC Certification Number. If the FCC ID and IC Certification Number are not visible when the module is installed inside another device, then the outside of the device into which the module is installed must also display a label referring to the enclosed module. In that case, the final end product must be labeled in a visible area with the following:

“Contains FCC ID: BEJ-LCW003”

“Contains IC: 2703N-LCW003”

<IC Warning Statements>

RSS-GEN, Sec. 7.1.3 – (licence-exempt radio apparatus)

This device complies with Industry Canada license-exempt RSS standard(s). Operation is subject to the following two conditions: (1) this device may not cause interference, and (2) this device must accept any interference, including interference that may cause undesired operation of the device.

Le présent appareil est conforme aux CNR d'Industrie Canada applicables aux appareils radio exempts de licence. L'exploitation est autorisée aux deux conditions suivantes : (1) l'appareil ne doit pas produire de brouillage, et (2) l'utilisateur de l'appareil doit accepter tout brouillage radioélectrique subi, même si le brouillage est susceptible d'en compromettre le fonctionnement.

9. Warning Statement

RF Exposure

The antenna (or antennas) must be installed so as to maintain at all times a distance minimum of at least 20 cm between the radiation source (antenna) and any individual. This device may not be installed or used in conjunction with any other antenna or transmitter.

l'exposition aux RF

L'antenne (ou les antennes) doit être installée de façon à maintenir à tout instant une distance minimum de au moins 20 cm entre la source de radiation (l'antenne) et toute personne physique.

Caution: Any changes or modifications to this device not explicitly approved by manufacturer could void your authority to operate this equipment.

Attention: Les changements ou modifications de cet appareil non expressément approuvé par le fabricant peuvent annuler votre droit à utiliser cet équipement.

Étiquetage du produit final (IC)

Le module BT111 est étiqueté avec sa propre identification FCC et son propre numéro de

certification IC. Si l'identification FCC et le numéro de certification IC ne sont pas visibles lorsque

le module est installé à l'intérieur d'un autre dispositif, la partie externe du dispositif dans lequel

le module est installé devra également présenter une étiquette faisant référence au module inclus.

Dans ce cas, le produit final devra être étiqueté sur une zone visible avec les informations

9. Warning Statement

suivantes :

« Contient module émetteur identification FCC ID : BEJ-LCW003

« Contient module émetteur IC : 2703N-LCW003”

The OEM integrator has to be aware not to provide information to the end user regarding how to install or remove this RF module or change RF related parameters in the user manual of the end product.

OEM Responsibilities to comply with FCC and Industry Canada Regulations

The module has been certified for integration into products only by OEM integrators under the following condition:

- The transmitter module must not be co-located or operating in conjunction with any other antenna or transmitter except in accordance with FCC multi-transmitter product procedures.

As long as the two condition above is met, further transmitter testing will not be required.

However, the OEM integrator is still responsible for testing their end-product for any additional compliance requirements required with this module installed (for example, digital device emissions, PC peripheral requirements, etc.).

IMPORTANT NOTE: In the event that these conditions can't be met (for certain configurations or co-location with another transmitter), then the FCC and Industry Canada authorizations are no longer considered valid and the FCC ID and IC Certification Number can't be used on the final product. In these circumstances, the OEM integrator will be responsible for re-evaluating the end product (including the transmitter) and obtaining a separate FCC and Industry Canada authorization.

9. Warning Statement

Responsabilités des OEM quant à la conformité avec les réglementations de FCC et d' Industrie Canada

Les modules ont été certifiés pour entrer dans la fabrication de produits exclusivement réalisés par des intégrateurs dans les conditions suivantes :

- Le module transmetteur ne doit pas être installé ou utilisé en concomitance avec une autre antenne ou un autre transmetteur.

Tant que ces deux conditions sont réunies, il n'est pas nécessaire de procéder à des tests

supplémentaires sur le transmetteur. Cependant, l'intégrateur est responsable des tests effectués sur le produit final afin de se mettre en conformité avec d'éventuelles exigences complémentaires lorsque le module est installé (exemple : émissions provenant d'appareils

numériques, exigences vis-à-vis de périphériques informatiques, etc.)

REMARQUE IMPORTANTE : En cas d'inobservance de ces conditions (en ce qui concerne

certaines configurations ou l'emplacement du dispositif à proximité d'un autre émetteur), les

autorisations de FCC et d'Industrie Canada ne seront plus considérées valables et l'identification de FCC et le numéro de certification d'IC ne pourront pas être utilisés sur le produit final. Dans ces cas, l'intégrateur OEM sera chargé d'évaluer à nouveau le produit final (y compris l'émetteur) et d'obtenir une autorisation indépendante de FCC et d'Industrie Canada.

- Dans le guide d'utilisation du produit final, l'intégrateur OEM doit s'abstenir de fournir des informations à l'utilisateur final portant sur les procédures à suivre pour installer ou retirer ce module RF ou pour changer les paramètres RF.