



ePA - Core 1 (SISO)

Mode	Packet Type	TX Frequency (MHz)	Band Edge Frequency (MHz)	Level (dBc)
Static	DH5	2402	2400	-67.19
Static	2-DH5	2402	2400	-63.87
Static	3-DH5	2402	2400	-63.23
Hopping	DH5	Hopping	2400	-72.11
Hopping	2-DH5	Hopping	2400	-69.31
Hopping	3-DH5	Hopping	2400	-68.80

Table 132 - SISO Authorised Band Edge Results

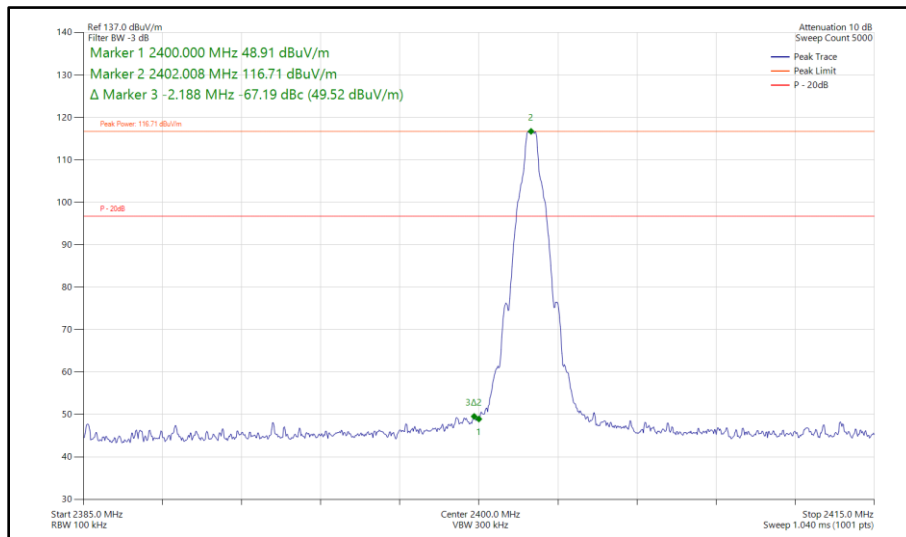
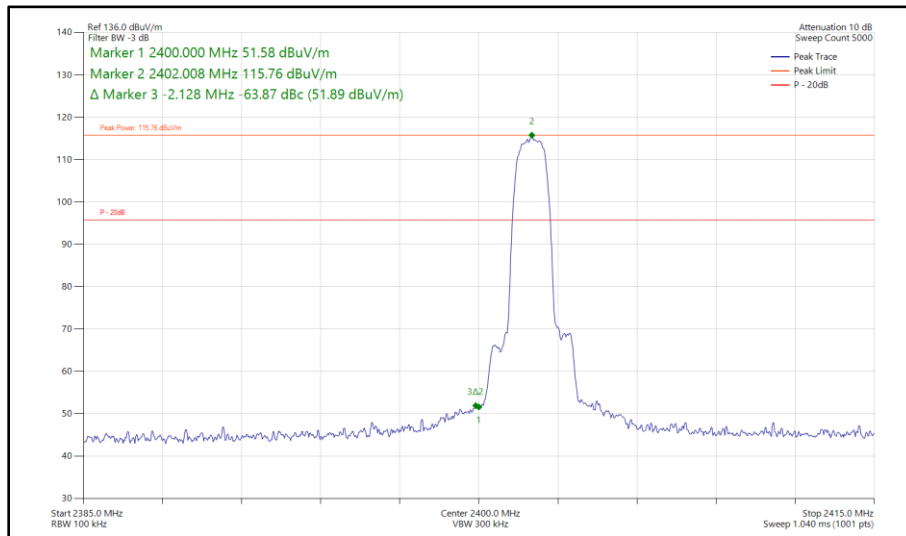
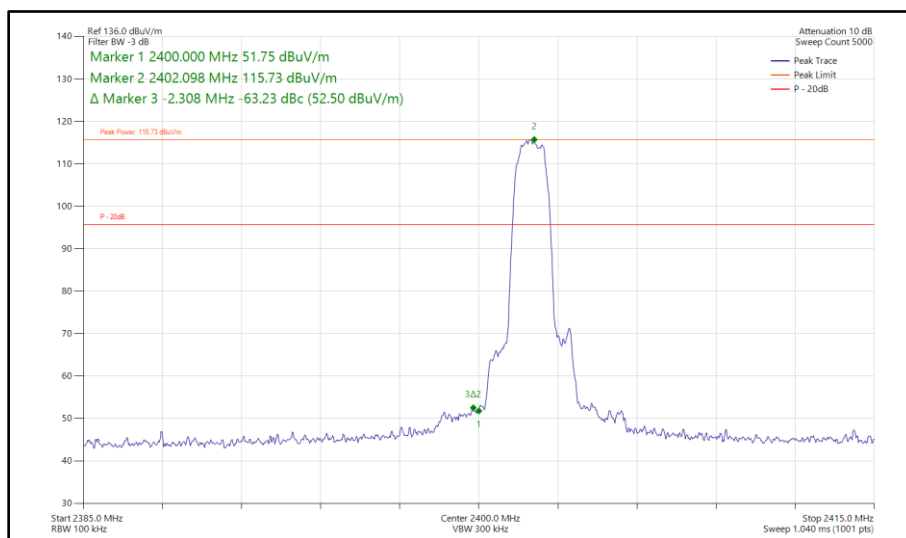

Figure 244 - Bluetooth DH5, SISO, Core 1 - 2402 MHz
 Band Edge Frequency 2400 MHz



**Figure 245 - Bluetooth 2-DH5, SISO, Core 1 - 2402 MHz
Band Edge Frequency 2400 MHz**



**Figure 246 - Bluetooth 3-DH5, SISO, Core 1 - 2402 MHz
Band Edge Frequency 2400 MHz**

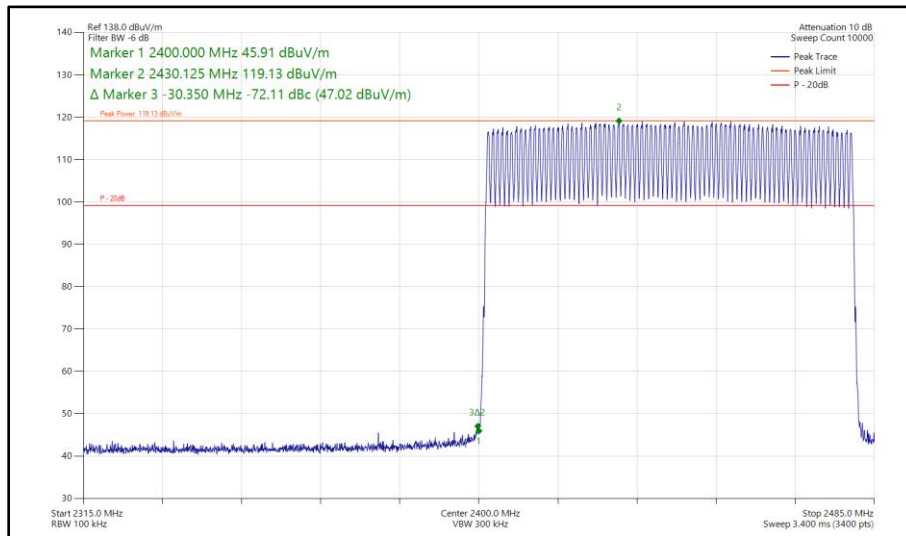

Figure 247 - Bluetooth DH5, SISO, Core 1 - Hopping Band Edge Frequency 2400 MHz

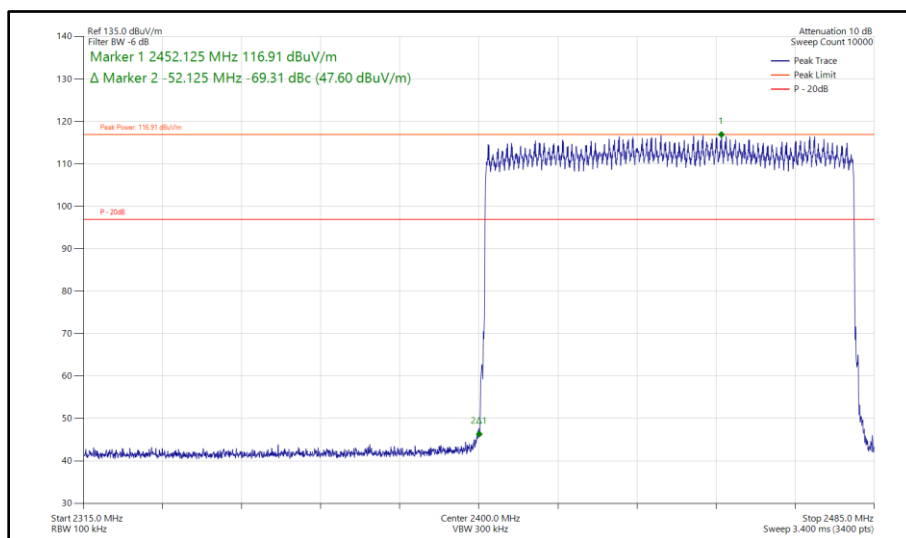

Figure 248 - Bluetooth 2-DH5, SISO, Core 1 - Hopping Band Edge Frequency 2400 MHz

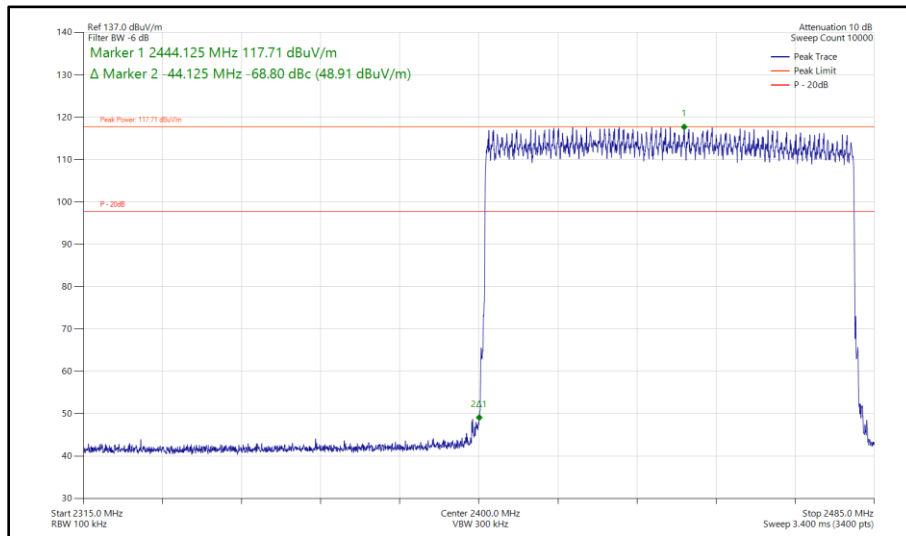

Figure 249 - Bluetooth 3-DH5, SISO, Core 1 - Hopping Band Edge Frequency 2400 MHz



ePA - Core 0 - Core 1 (MIMO)

Mode	Packet Type	TX Frequency (MHz)	Band Edge Frequency (MHz)	Level (dBc)
Static	DH5	2402	2400	-67.13
Static	2-DH5	2402	2400	-62.31
Static	3-DH5	2402	2400	-61.64
Hopping	DH5	Hopping	2400	-72.69
Hopping	2-DH5	Hopping	2400	-69.69
Hopping	3-DH5	Hopping	2400	-69.47

Table 133 - MIMO Authorised Band Edge Results

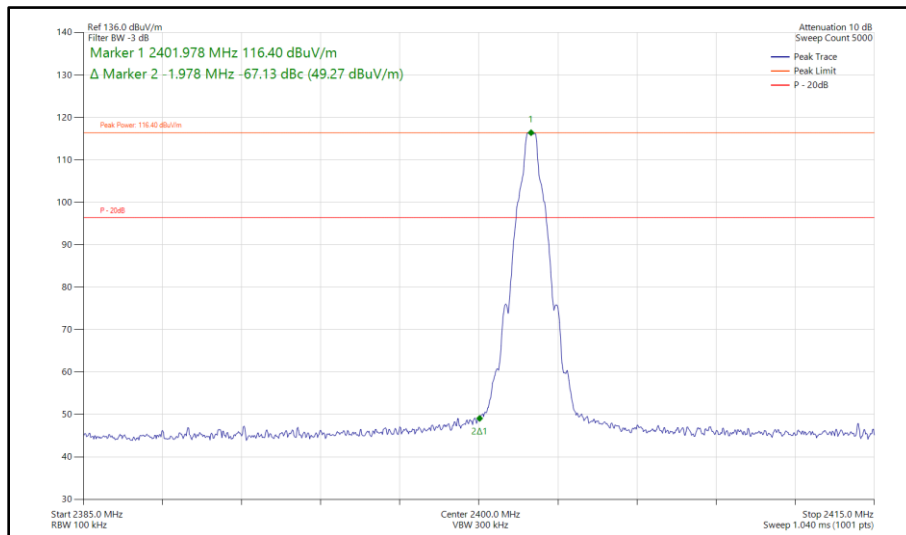

**Figure 250 - Bluetooth DH5, MIMO, Core 0 - Core 1 - 2402 MHz
 Band Edge Frequency 2400 MHz**

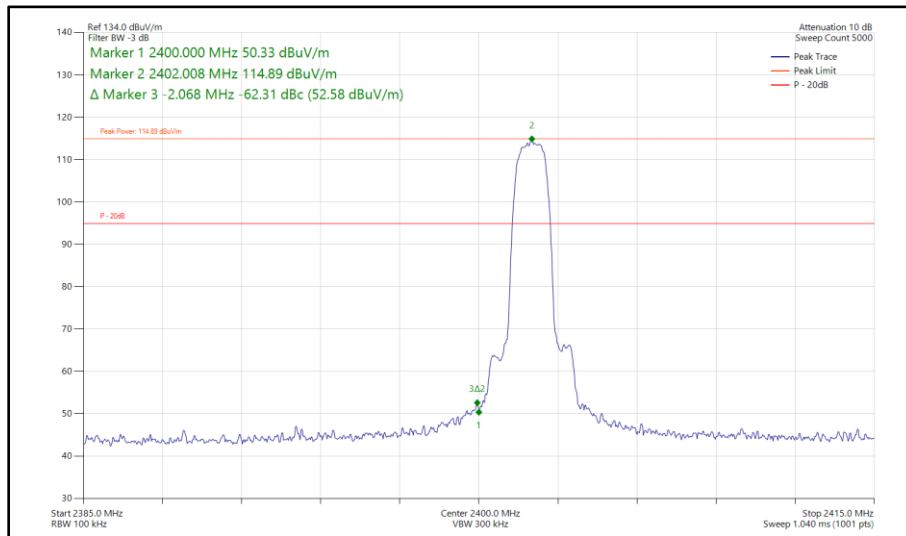

**Figure 251 - Bluetooth 2-DH5, MIMO, Core 0 - Core 1 - 2402 MHz
Band Edge Frequency 2400 MHz**

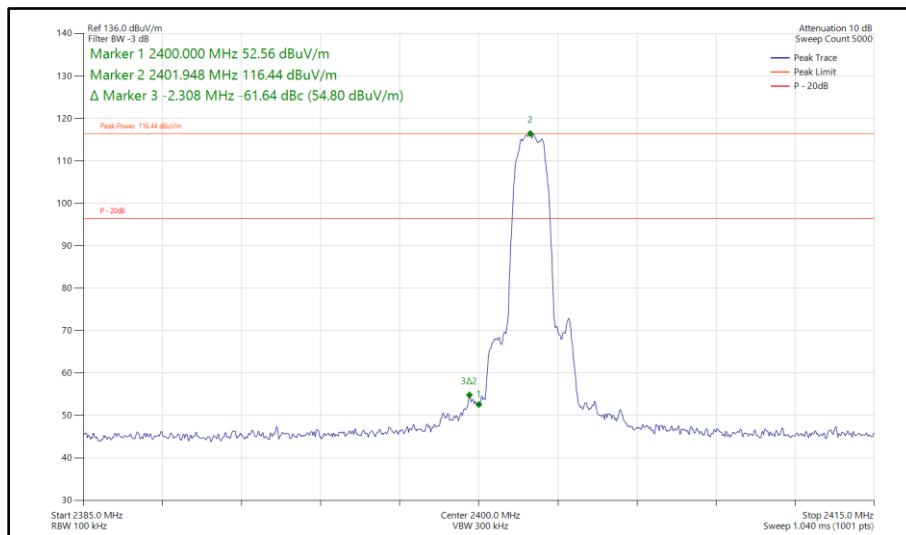

**Figure 252 - Bluetooth 3-DH5, MIMO, Core 0 - Core 1 - 2402 MHz
Band Edge Frequency 2400 MHz**

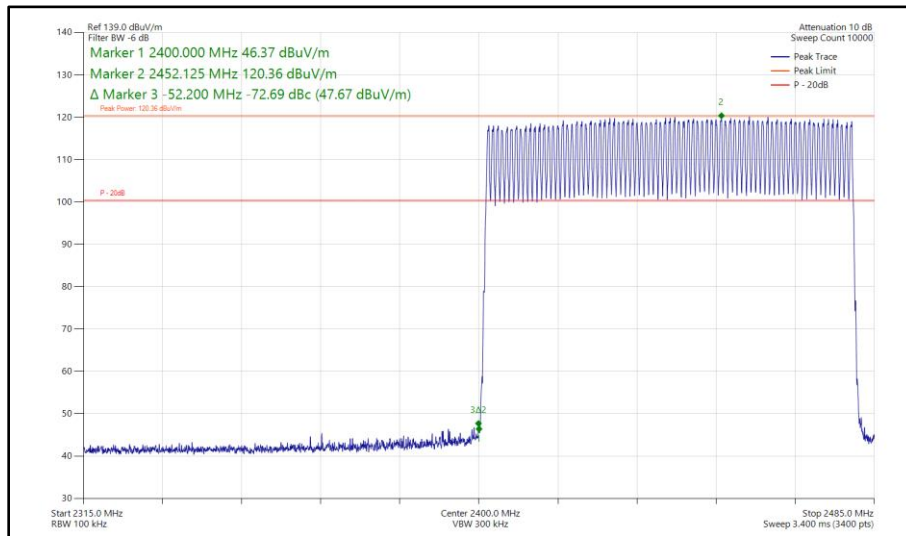

Figure 253 - Bluetooth DH5, MIMO, Core 0 - Core 1 - Hopping Band Edge Frequency 2400 MHz

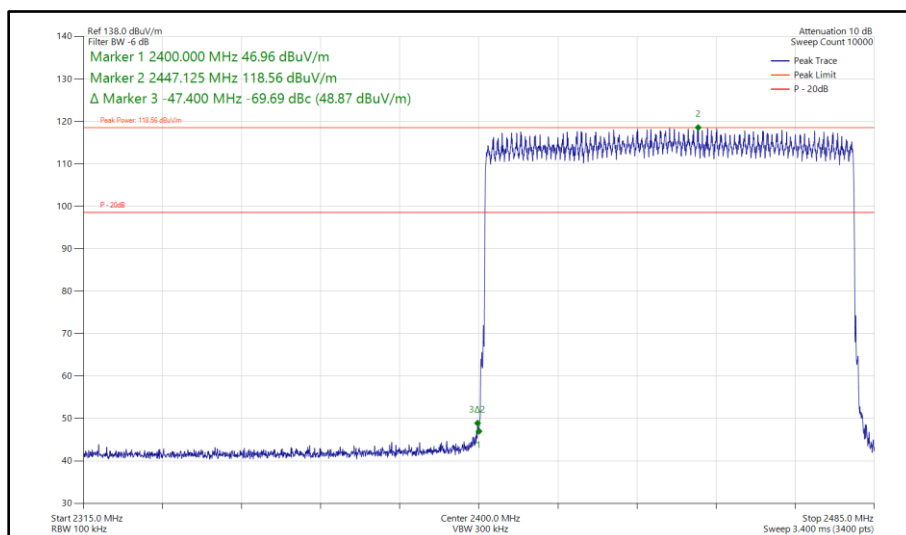

Figure 254 - Bluetooth 2-DH5, MIMO, Core 0 - Core 1 - Hopping Band Edge Frequency 2400 MHz

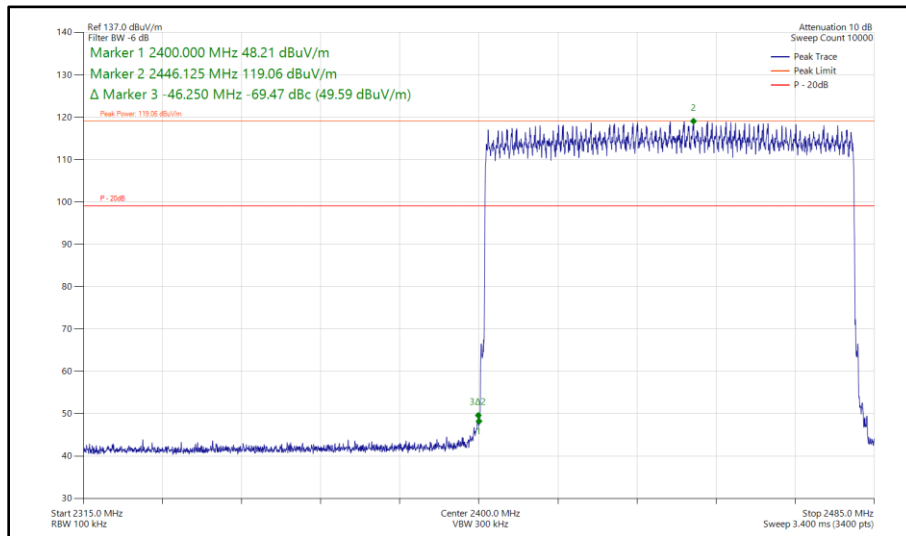

Figure 255 - Bluetooth 3-DH5, MIMO, Core 0 - Core 1 - Hopping Band Edge Frequency 2400 MHz

FCC 47 CFR Part 15, Limit Clause 15.247 (d)

20 dB below the fundamental measured in a 100 kHz bandwidth using a peak detector. If the transmitter complies with the conducted power limits, based on the use of RMS averaging over a time interval, the attenuation required shall be 30 dB below the fundamental instead of 20 dB.

ISED RSS-247, Limit Clause 5.5

In any 100 kHz bandwidth outside the frequency band in which the spread spectrum or digitally modulated device is operating, the RF power that is produced shall be at least 20 dB below that in the 100 kHz bandwidth within the band that contains the highest level of the desired power, based on either an RF conducted or a radiated measurement, provided that the transmitter demonstrates compliance with the peak conducted power limits. If the transmitter complies with the conducted power limits based on the use of root-mean-square averaging over a time interval, as permitted under Section 5.4(4), the attenuation required shall be 30 dB instead of 20 dB. Attenuation below the general field strength limits specified in RSS-Gen is not required.



2.7.7 Test Location and Test Equipment Used

This test was carried out in RF Chamber 14 and RF Chamber 15.

Instrument	Manufacturer	Type No.	TE No.	Calibration Period (months)	Calibration Expiry Date
Emissions Software	TUV SUD	EmX V3.2.0	5125	-	Software
EMI Test Receiver	Rohde & Schwarz	ESW44	5911	12	11-Sep-2024
EMI Test Receiver	Rohde & Schwarz	ESW44	5912	12	05-Jul-2024
1500W (300V 12A) AC Power Supply	iTech	IT7324	5955	-	O/P Mon
1500W (300V 12A) AC Power Supply	iTech	IT7324	5956	-	O/P Mon
5m Semi-Anechoic Chamber (Dual-Axis)	Albatross Projects	RF Chamber 14	5958	36	26-Apr-2025
Compact Antenna Mast	Maturo Gmbh	CAM4.0-P	5959	-	TU
Mast & Turntable Controller	Maturo Gmbh	FCU3.0	5960	-	TU
Tilt Antenna Mast	Maturo Gmbh	BAM4.5-P	5961	-	TU
Turntable	Maturo Gmbh	TT1.5SI	5962	-	TU
5m Semi-Anechoic Chamber (Dual-Axis), Chamber 15	Albatross Projects	RF Chamber 15	5963	36	28-Apr-2025
Compact Antenna Mast	Maturo Gmbh	CAM4.0-P	5964	-	TU
Mast & Turntable Controller	Maturo Gmbh	FCU3.0	5966	-	TU
Tilt Antenna Mast	Maturo Gmbh	BAM4.5-P	5967	-	TU
Turntable	Maturo Gmbh	TT1.5SI	5968	-	TU
Cable (SMA to SMA 1m)	Junkosha	MWX221-01000AMSAMS/A	5996	12	05-Jun-2024
Cable (SMA to SMA 6.5m)	Junkosha	MWX221-06500AMSAMS/B	6003	12	05-Jun-2024
Cable (SMA to SMA 1m)	Junkosha	MWX221-01000AMSAMS/A	6007	12	05-Jun-2024
Horn Antenna (1-10 GHz)	Schwarzbeck	BBHA9120B	6141	12	26-Aug-2024
Horn Antenna (1-10 GHz)	Schwarzbeck	BBHA9120B	6142	12	26-Aug-2024
Digital Multimeter	Fluke	115	6145	12	15-Jun-2024
Digital Multimeter	Fluke	115	6147	12	16-Jun-2024
Humidity and Temperature Meter	R.S Components	1364	6148	12	21-Jul-2024
Humidity & Temperature meter	R.S Components	1364	6149	12	07-Jul-2024
SAC Switch Unit	TUV SUD	TUV_SSU_004 PLC	6349	12	01-May-2024
1m Cable	Junkosha	MWX241-01000AMSAMS/B	6741	12	01-Feb-2025

Table 134

TU - Traceability Unscheduled

O/P Mon - Output Monitored using calibrated equipment



2.8 Spurious Radiated Emissions

2.8.1 Specification Reference

FCC 47 CFR Part 15C, Clause 15.209 and 15.247 (d)
ISED RSS-247, Clause 3.3 and 5.5
ISED RSS-GEN, Clause 6.13 and 8.9

2.8.2 Equipment Under Test and Modification State

A3247, S/N: KN47NTDQRY - Modification State 0

2.8.3 Date of Test

20-June-2024 to 25-June-2024

2.8.4 Test Method

This test was performed in accordance with ANSI C63.10, clause 6.3, 6.5 and 6.6.

The EUT was placed on the non-conducting platform in a manner typical of a normal installation.

In the 30 MHz to 1 GHz range pre-scans were only performed on the mid channel (2441 MHz) only.

The plots shown are the characterisation of the EUT. The limits on the plots represent the most stringent case for restricted bands, (74/54 dBuV/m) when compared to 20 dBc outside restricted bands. The limits shown have been used as a threshold to determine where further measurements are necessary. Where results are within 20 dB of the limits shown on the plots, further investigation was carried out and reported in results tables.

Ports on the EUT were terminated with loads as described in ANSI C63.4 clause 6.2.4. For EUT's with multiple connectors of the same type, additional interconnecting cables were connected, and pre-scans performed to determine whether the level of the emissions were increased by >2 dB.

The following conversion can be applied to convert from dB μ V/m to μ V/m:
 $10^{(\text{Field Strength in dB}\mu\text{V/m}/20)}$.

Above 18 GHz, the measurement distance was reduced to 1 m. The limit line was increased by $20 \cdot \text{LOG}(3/1) = 9.54$ dB.

Where formal measurements have been necessary, the results have been presented in the emissions table.

2.8.5 Example Test Setup Diagram

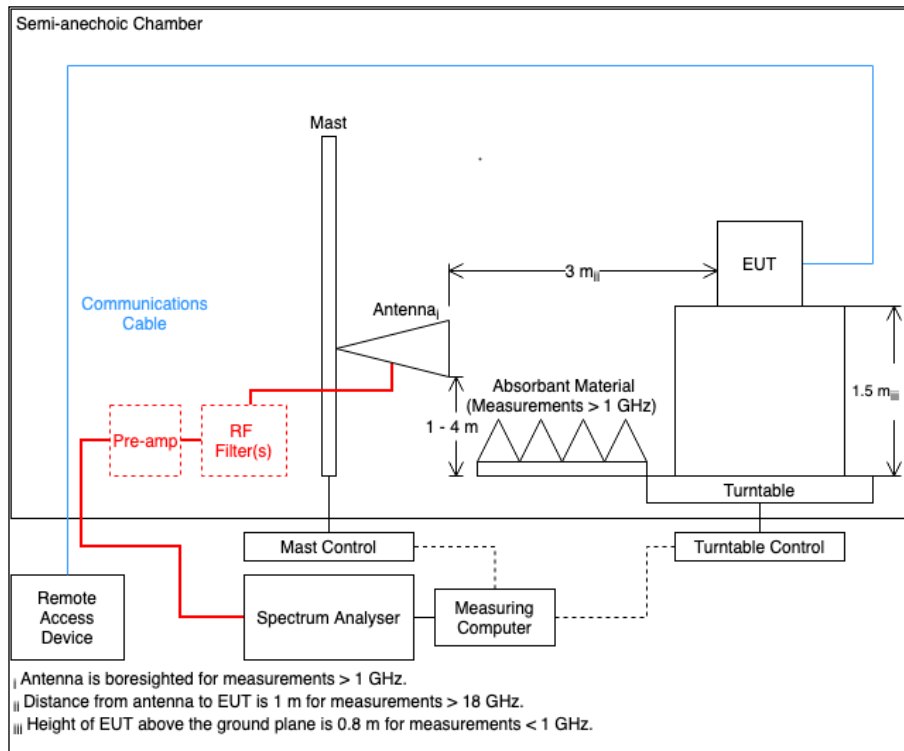

Figure 256

2.8.6 Environmental Conditions

Ambient Temperature	20.4 - 24.5 °C
Relative Humidity	39.5 - 46.1 %



2.8.7 Test Results

2.4 GHz Bluetooth BDR/EDR

Frequency (MHz)	Level (dB μ V/m)	Limit (dB μ V/m)	Margin (dB)	Detector	Angle (°)	Height (cm)	Polarisation
2373.630	60.75	74.00	-13.25	Peak	180	166	Vertical
2373.778	60.16	74.00	-13.84	Peak	123	100	Horizontal

Table 135 - 2402 MHz (CH0), DH5, ePA, Core 0 + Core 1, 1 GHz to 26 GHz

No other emissions found within 10 dB of the limit.

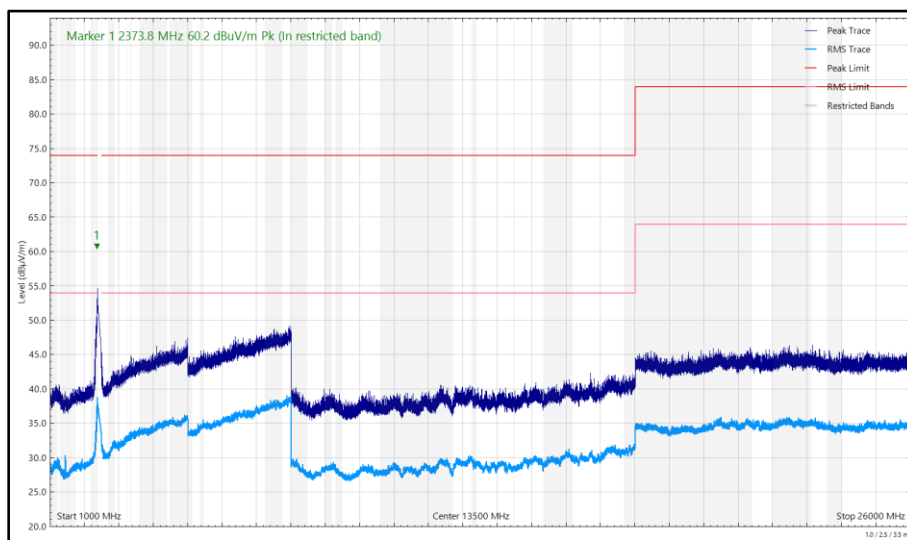

Figure 257 - 2402 MHz (CH0), DH5, ePA, Core 0 + Core 1, 1 GHz to 26 GHz, Horizontal

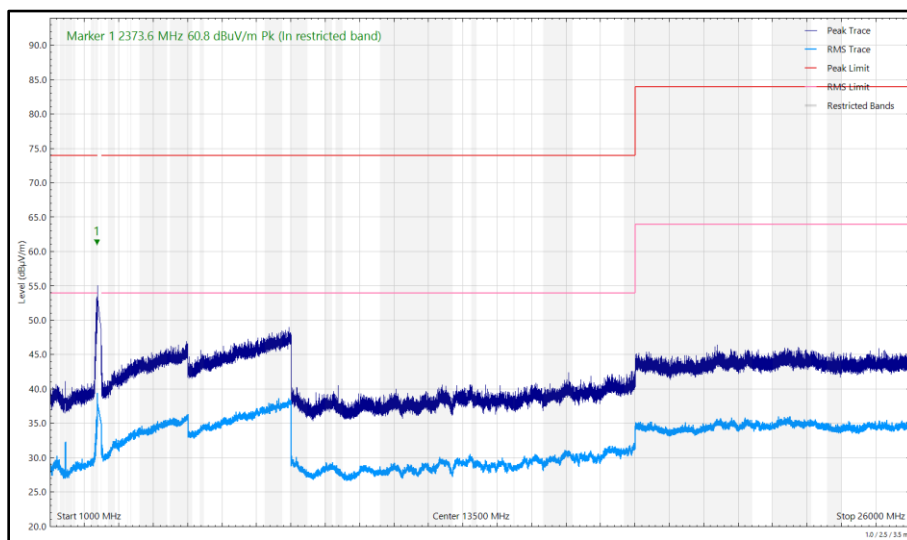

Figure 258 - 2402 MHz (CH0), DH5, ePA, Core 0 + Core 1, 1 GHz to 26 GHz, Vertical



Frequency (MHz)	Level (dB μ V/m)	Limit (dB μ V/m)	Margin (dB)	Detector	Angle (°)	Height (cm)	Polarisation
2382.208	57.25	74.00	-16.75	Peak	196	191	Vertical

Table 136 - 2441 MHz (CH39), DH5, ePA, Core 0 + Core 1, 30 MHz to 26 GHz

No other emissions found within 10 dB of the limit.

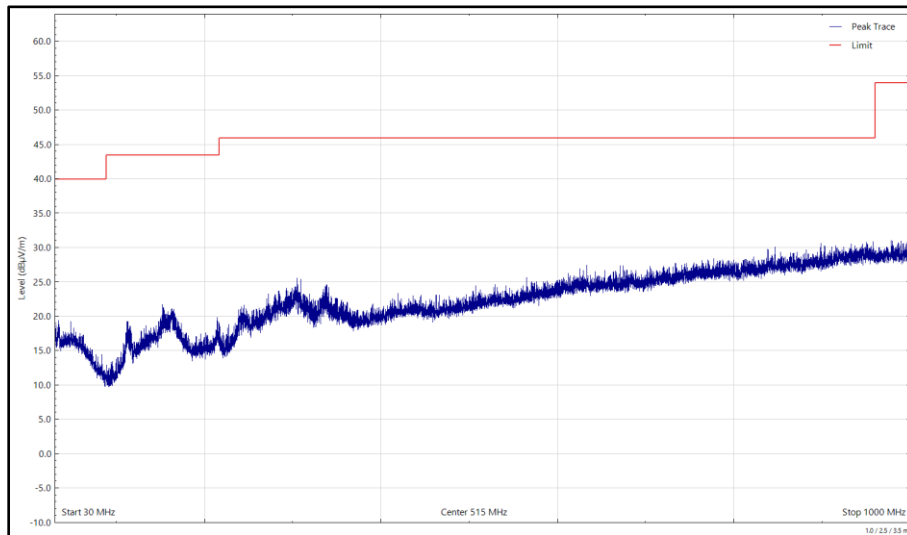

Figure 259 - 2441 MHz (CH39), DH5, ePA, Core 0 + Core 1, 30 MHz to 1 GHz, Horizontal (Peak)

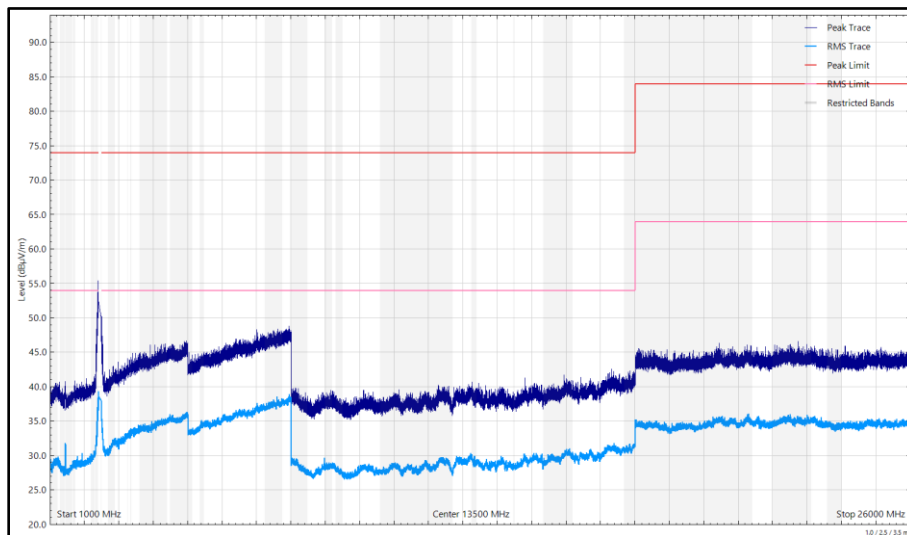

Figure 260 - 2441 MHz (CH39), DH5, ePA, Core 0 + Core 1, 1 GHz to 26 GHz, Horizontal

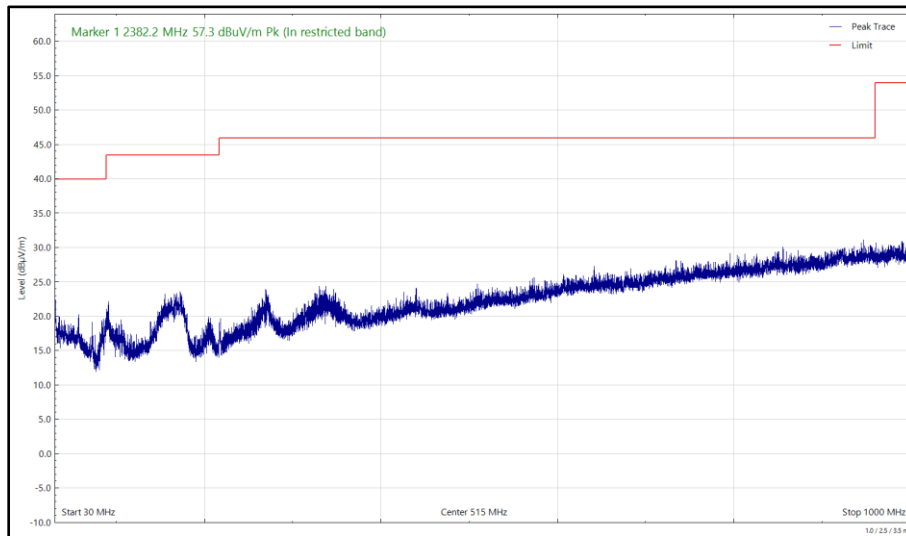

Figure 261 - 2441 MHz (CH39), DH5, ePA, Core 0 + Core 1, 30 MHz to 1 GHz, Vertical (Peak)

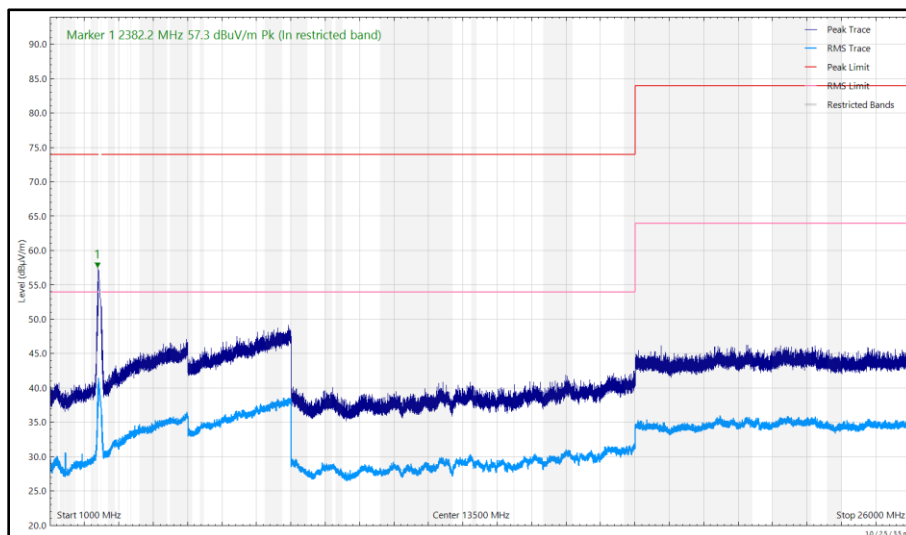

Figure 262 - 2441 MHz (CH39), DH5, ePA, Core 0 + Core 1, 1 GHz to 26 GHz, Vertical



Frequency (MHz)	Level (dB μ V/m)	Limit (dB μ V/m)	Margin (dB)	Detector	Angle (°)	Height (cm)	Polarisation
2499.161	35.58	54.00	-18.42	CISPR Avg	120	149	Horizontal
2499.704	34.53	54.00	-19.47	CISPR Avg	185	171	Vertical

Table 137 - 2480 MHz (CH78), DH5, ePA, Core 0 + Core 1, 1 GHz to 26 GHz

No other emissions found within 10 dB of the limit.

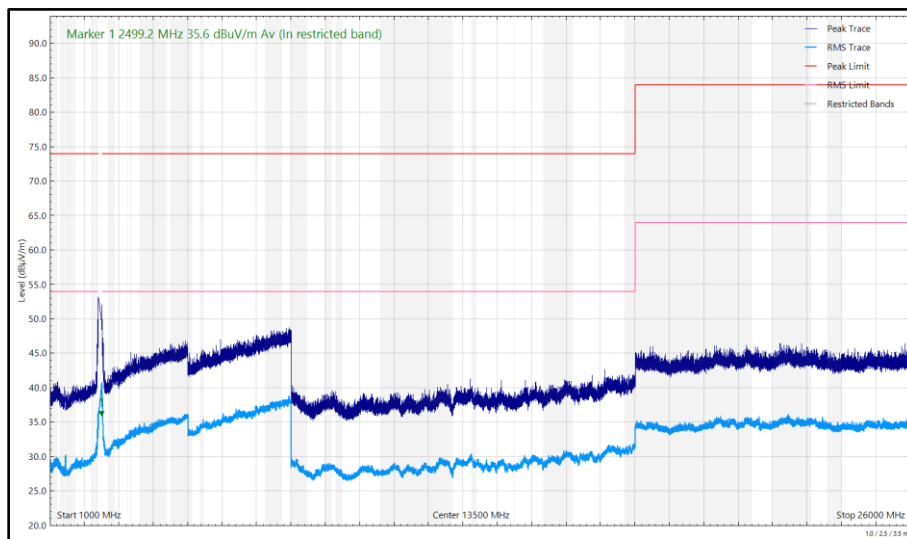

Figure 263 - 2480 MHz (CH78), DH5, ePA, Core 0 + Core 1, 1 GHz to 26 GHz, Horizontal

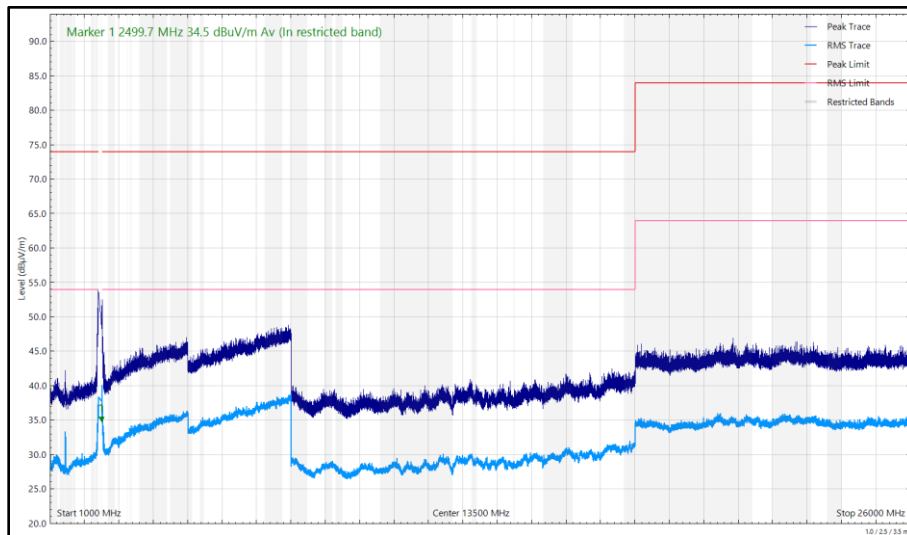

Figure 264 - 2480 MHz (CH78), DH5, ePA, Core 0 + Core 1, 1 GHz to 26 GHz, Vertical



Frequency (MHz)	Level (dB μ V/m)	Limit (dB μ V/m)	Margin (dB)	Detector	Angle (°)	Height (cm)	Polarisation
*							

Table 138 - 2402 MHz (CH0), DH5, iPA, Core 0 + Core 1, 1 GHz to 26 GHz

*No emissions found within 10 dB of the limit.

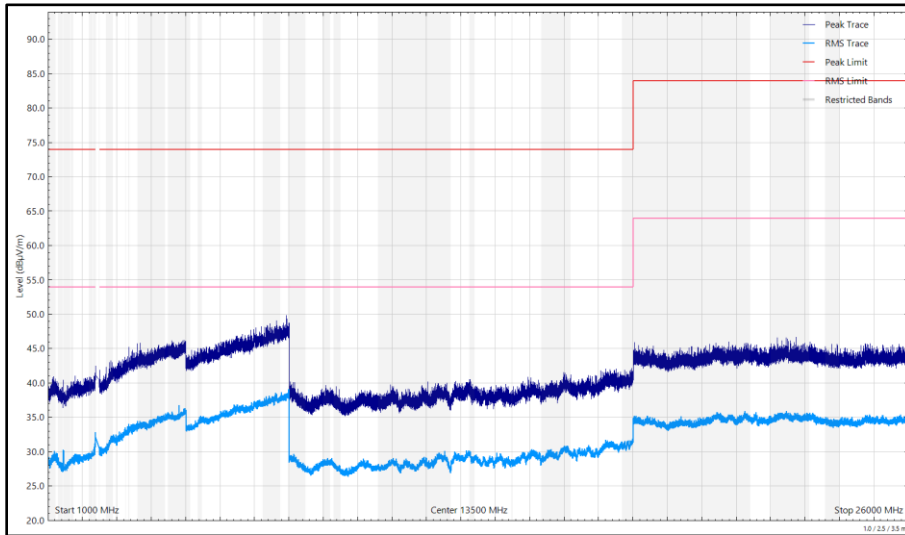

Figure 265 - 2402 MHz (CH0), DH5, iPA, Core 0 + Core 1, 1 GHz to 26 GHz, Horizontal

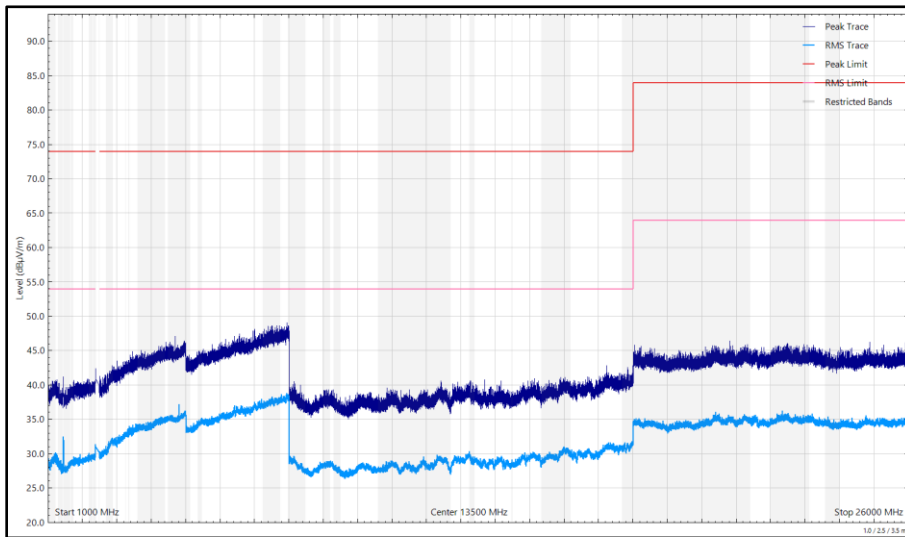

Figure 266 - 2402 MHz (CH0), DH5, iPA, Core 0 + Core 1, 1 GHz to 26 GHz, Vertical



Frequency (MHz)	Level (dB μ V/m)	Limit (dB μ V/m)	Margin (dB)	Detector	Angle (°)	Height (cm)	Polarisation
*							

Table 139 - 2441 MHz (CH39), DH5, iPA, Core 0 + Core 1, 30 MHz to 26 GHz

*No emissions found within 10 dB of the limit.

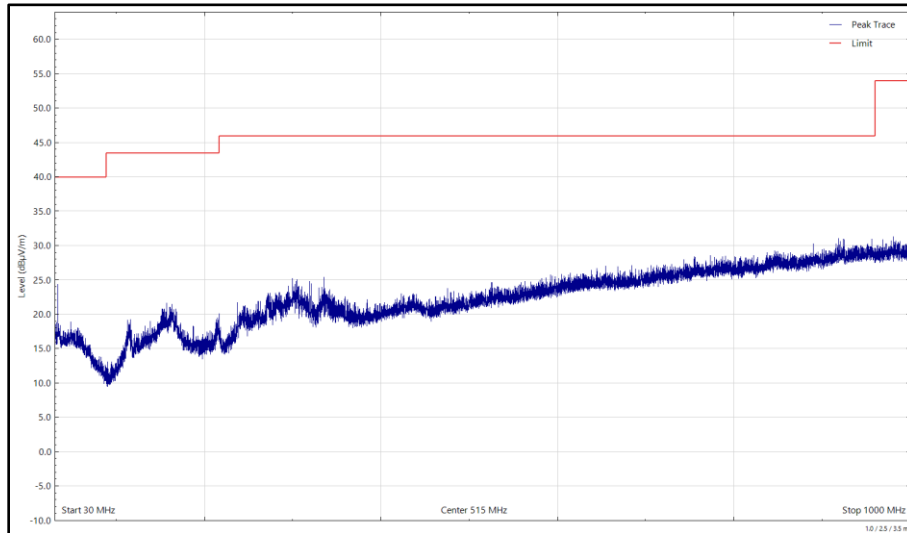

Figure 267 - 2441 MHz (CH39), DH5, iPA, Core 0 + Core 1, 30 MHz to 1 GHz, Horizontal (Peak)

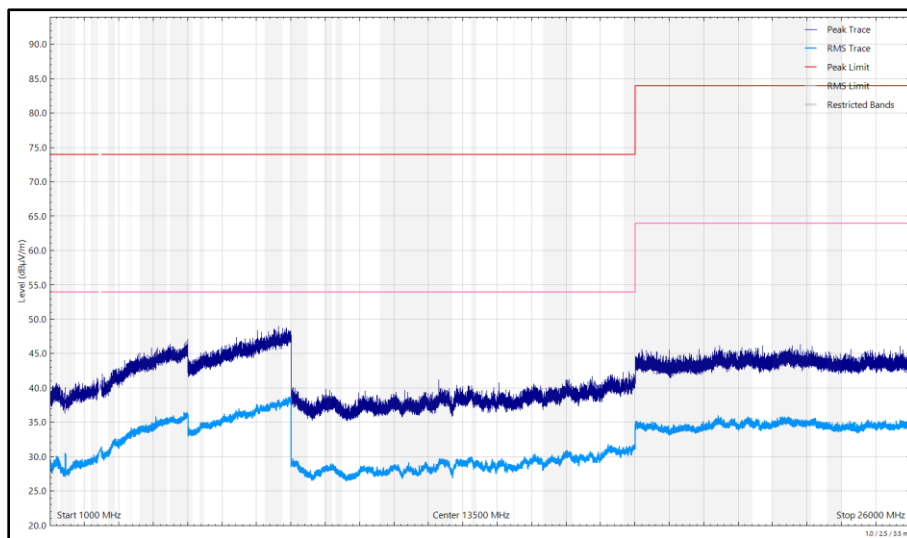

Figure 268 - 2441 MHz (CH39), DH5, iPA, Core 0 + Core 1, 1 GHz to 26 GHz, Horizontal

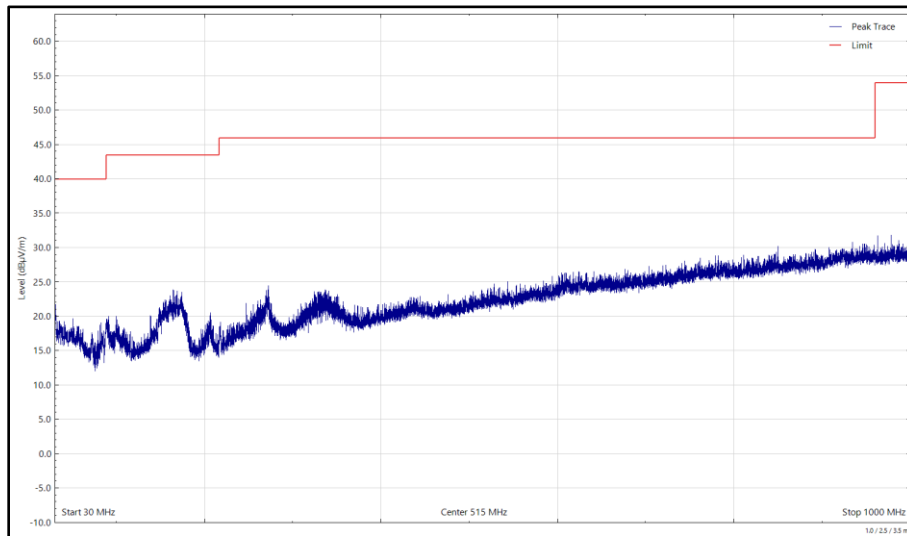

Figure 269 - 2441 MHz (CH39), DH5, iPA, Core 0 + Core 1, 30 MHz to 1 GHz, Vertical (Peak)

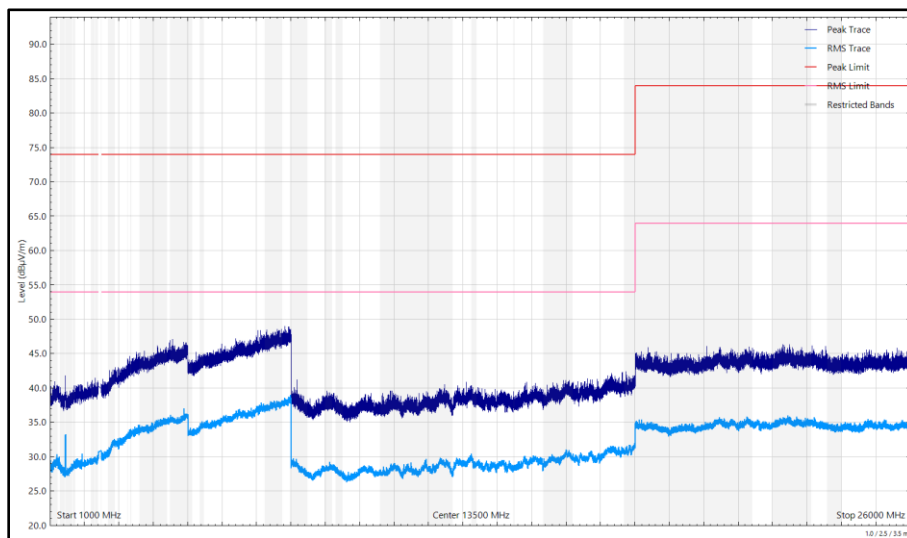

Figure 270 - 2441 MHz (CH39), DH5, iPA, Core 0 + Core 1, 1 GHz to 26 GHz, Vertical



Frequency (MHz)	Level (dB μ V/m)	Limit (dB μ V/m)	Margin (dB)	Detector	Angle (°)	Height (cm)	Polarisation
*							

Table 140 - 2480 MHz (CH78), DH5, iPA, Core 0 + Core 1, 1 GHz to 26 GHz

*No emissions found within 10 dB of the limit.

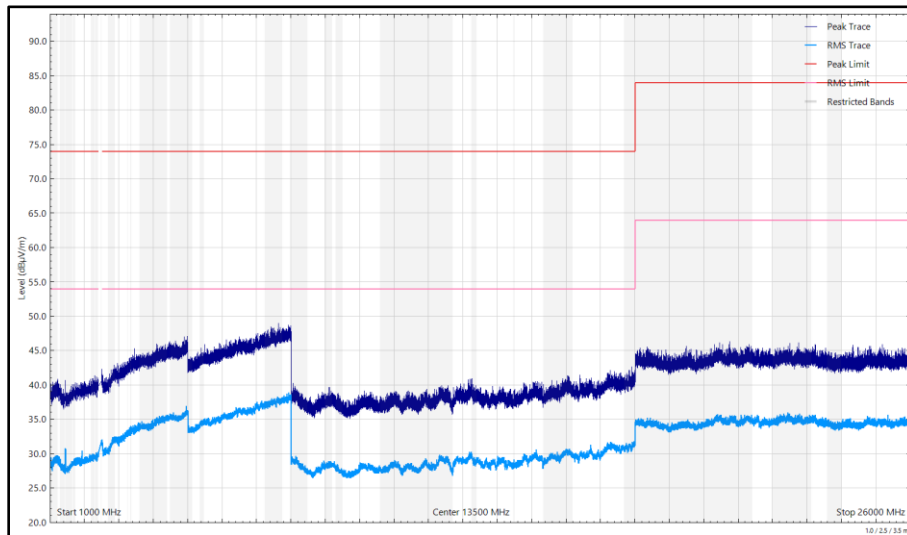

Figure 271 - 2480 MHz (CH78), DH5, iPA, Core 0 + Core 1, 1 GHz to 26 GHz, Horizontal

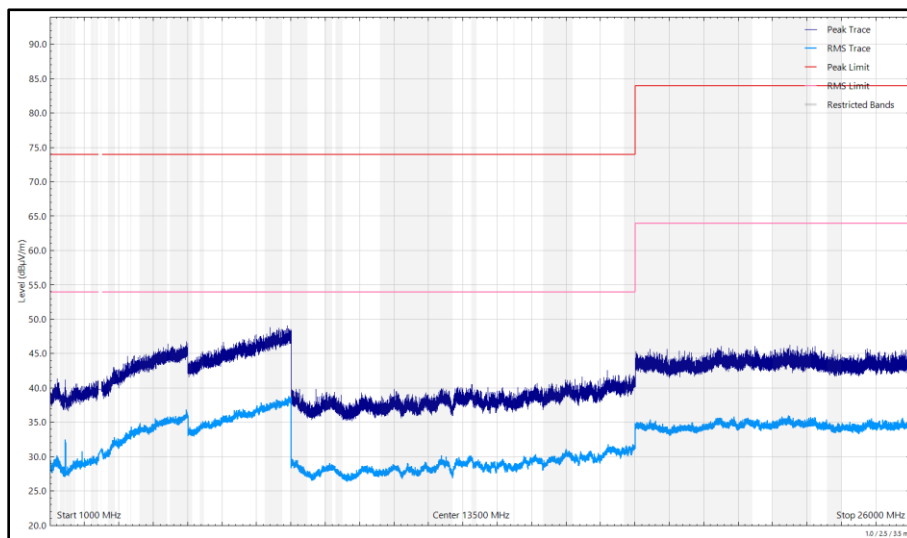

Figure 272 - 2480 MHz (CH78), DH5, iPA, Core 0 + Core 1, 1 GHz to 26 GHz, Vertical



Frequency (MHz)	Level (dB μ V/m)	Limit (dB μ V/m)	Margin (dB)	Detector	Angle (°)	Height (cm)	Polarisation
*							

Table 141 - 2402 MHz (CH0), DH5, iPA, Core 2, 1 GHz to 26 GHz

*No emissions found within 10 dB of the limit.

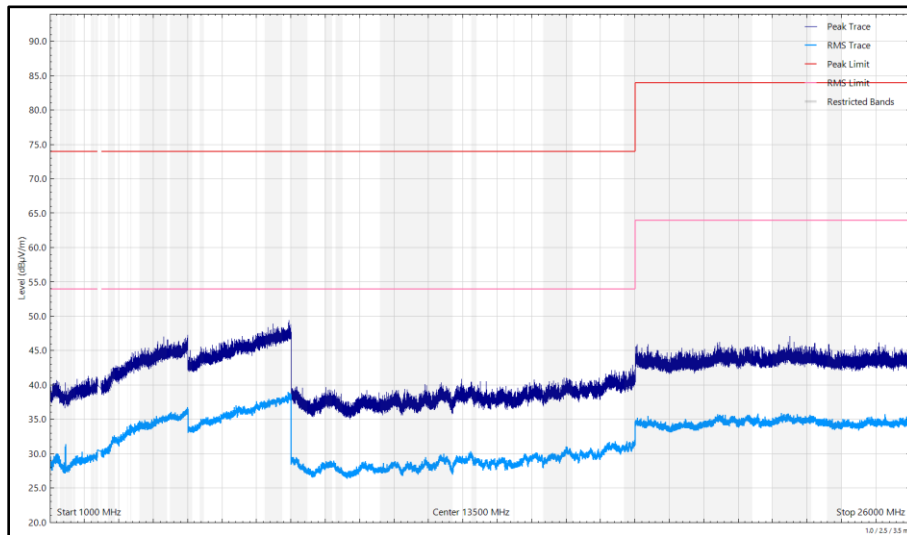

Figure 273 - 2402 MHz (CH0), DH5, iPA, Core 2, 1 GHz to 26 GHz, Horizontal

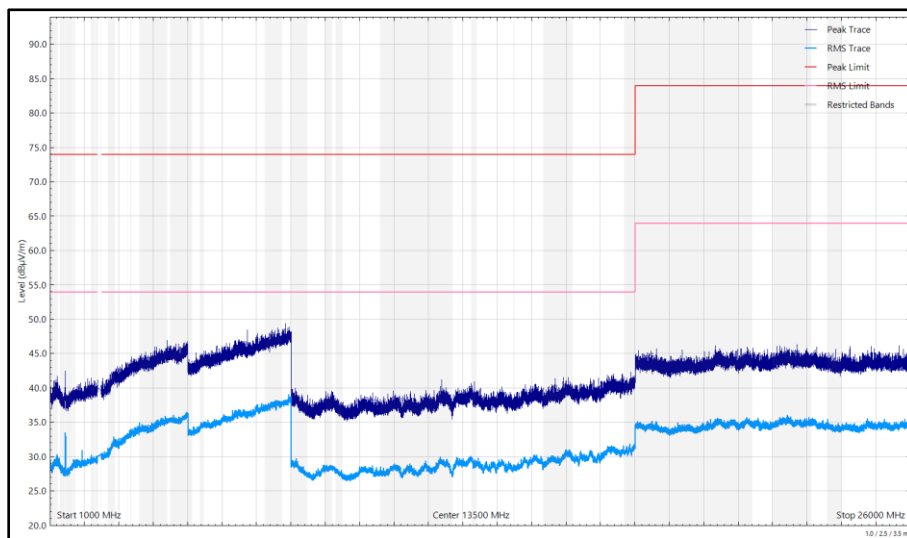

Figure 274 - 2402 MHz (CH0), DH5, iPA, Core 2, 1 GHz to 26 GHz, Vertical



Frequency (MHz)	Level (dB μ V/m)	Limit (dB μ V/m)	Margin (dB)	Detector	Angle (°)	Height (cm)	Polarisation
*							

Table 142 - 2441 MHz (CH39), DH5, iPA, Core 2, 30 MHz to 26 GHz

*No emissions found within 10 dB of the limit.

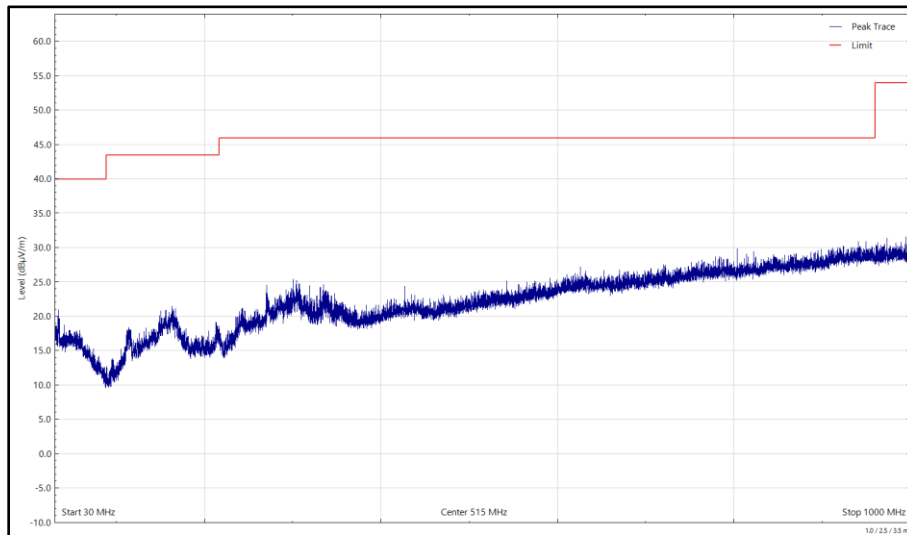

Figure 275 - 2441 MHz (CH39), DH5, iPA, Core 2, 30 MHz to 1 GHz, Horizontal (Peak)

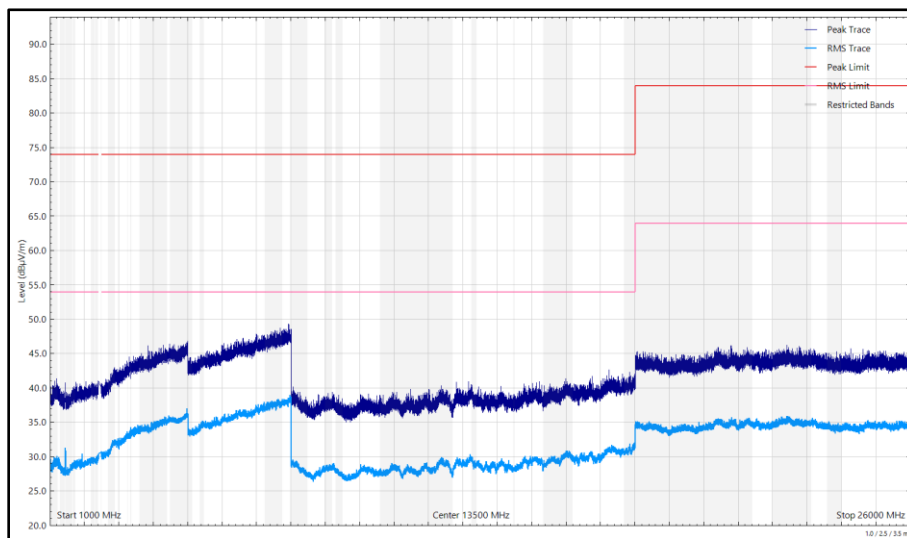

Figure 276 - 2441 MHz (CH39), DH5, iPA, Core 2, 1 GHz to 26 GHz, Horizontal

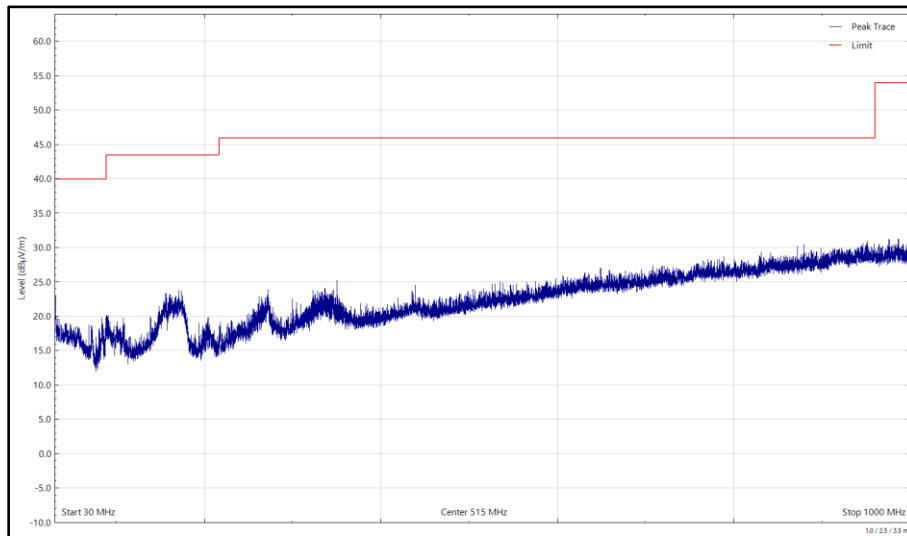

Figure 277 - 2441 MHz (CH39), DH5, iPA, Core 2, 30 MHz to 1 GHz, Vertical (Peak)

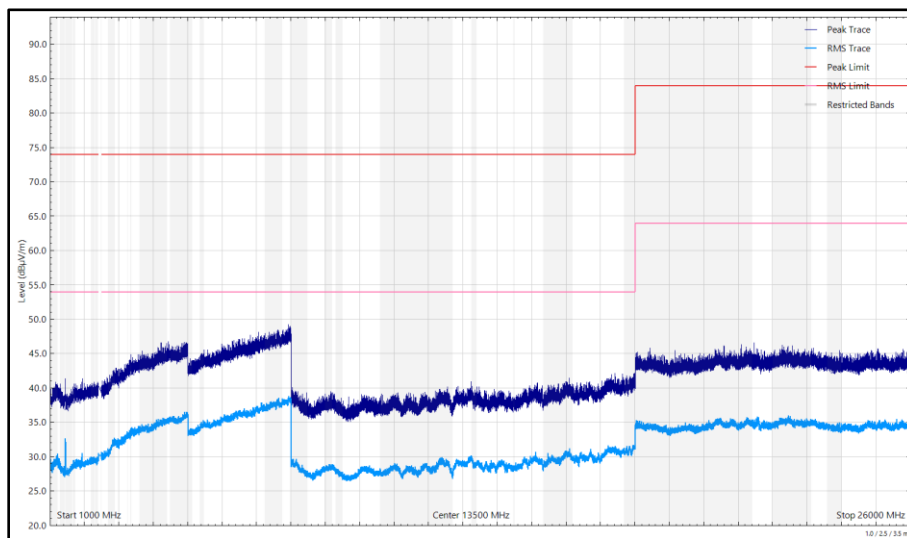

Figure 278 - 2441 MHz (CH39), DH5, iPA, Core 2, 1 GHz to 26 GHz, Vertical



Frequency (MHz)	Level (dB μ V/m)	Limit (dB μ V/m)	Margin (dB)	Detector	Angle (°)	Height (cm)	Polarisation
*							

Table 143 - 2480 MHz (CH78), DH5, iPA, Core 2, 1 GHz to 26 GHz

*No emissions found within 10 dB of the limit.

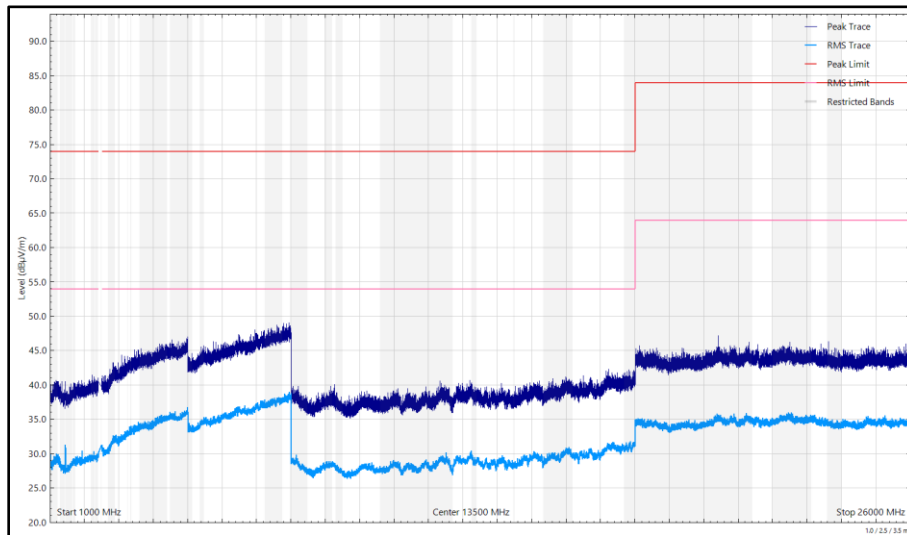

Figure 279 - 2480 MHz (CH78), DH5, iPA, Core 2, 1 GHz to 26 GHz, Horizontal

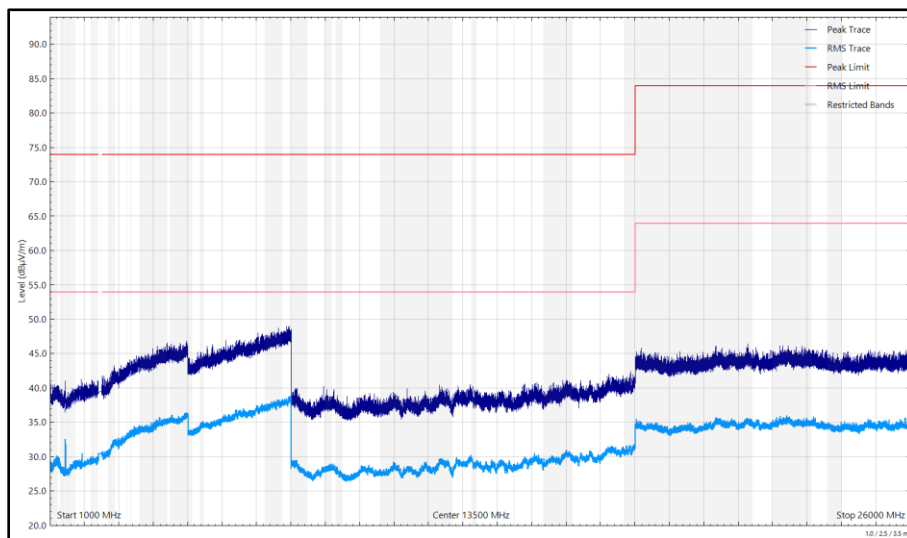

Figure 280 - 2480 MHz (CH78), DH5, iPA, Core 2, 1 GHz to 26 GHz, Vertical



FCC 47 CFR Part 15, Limit Clause 15.247 (d)

In any 100 kHz bandwidth outside the frequency band in which the spread spectrum or digitally modulated intentional radiator is operating, the radio frequency power that is produced by the intentional radiator shall be at least 20 dB below that in the 100 kHz bandwidth within the band that contains the highest level of the desired power, based on either an RF conducted or a radiated measurement, provided the transmitter demonstrates compliance with the peak conducted power limits. If the transmitter complies with the conducted power limits based on the use of RMS averaging over a time interval, as permitted under paragraph (b)(3) of this section, the attenuation required under this paragraph shall be 30 dB instead of 20 dB.

Attenuation below the general limits specified in § 15.209(a) is not required. In addition, radiated emissions which fall in the restricted bands, as defined in § 15.205(a), must also comply with the radiated emission limits specified in 15.209(a)

ISED RSS-247, Limit Clause 5.5

In any 100 kHz bandwidth outside the frequency band in which the spread spectrum or digitally modulated device is operating, the RF power that is produced shall be at least 20 dB below that in the 100 kHz bandwidth within the band that contains the highest level of the desired power, based on either an RF conducted or a radiated measurement, provided that the transmitter demonstrates compliance with the peak conducted power limits. If the transmitter complies with the conducted power limits based on the use of root-mean-square averaging over a time interval, as permitted under Section 5.4(4), the attenuation required shall be 30 dB instead of 20 dB. Attenuation below the general field strength limits specified in RSS-Gen is not required.

In addition, radiated emissions which fall in the restricted bands, as defined in RSS-GEN, clause 8.10, must also comply with the radiated emission limits specified in RSS-GEN clause 8.9.



2.8.8 Test Location and Test Equipment Used

This test was carried out in RF Chamber 14 and RF Chamber 18.

Instrument	Manufacturer	Type No.	TE No.	Calibration Period (months)	Calibration Expiry Date
Emissions Software	TUV SUD	EmX V3.2.0	5125	-	Software
Antenna (DRG 1-10.5GHz)	Schwarzbeck	BBHA9120B	5232	12	09-Jul-2024
DRG Horn Antenna (7.5-18GHz)	Schwarzbeck	HWRD750	5939	12	05-May-2025
1500W (300V 12A) AC Power Supply	iTech	IT7324	5955	-	O/P Mon
1500W (300V 12A) AC Power Supply	iTech	IT7324	5956	-	O/P Mon
5m Semi-Anechoic Chamber (Dual-Axis)	Albatross Projects	RF Chamber 14	5958	36	26-Apr-2025
Compact Antenna Mast	Maturo Gmbh	CAM4.0-P	5959	-	TU
Mast & Turntable Controller	Maturo Gmbh	FCU3.0	5960	-	TU
Tilt Antenna Mast	Maturo Gmbh	BAM4.5-P	5961	-	TU
Turntable	Maturo Gmbh	TT1.5SI	5962	-	TU
Cable (N to N 1m)	Junkosha	MWX221-01000AMSAMS/B	6009	12	20-May-2025
Horn Antenna (1-10 GHz)	Schwarzbeck	BBHA9120B	6140	12	05-May-2025
Horn Antenna (1-10 GHz)	Schwarzbeck	BBHA9120B	6141	12	05-May-2025
SAC Switch Unit	TUV SUD	TUV_SSU_001	6144	12	11-Dec-2024
Digital Multimeter	Fluke	115	6145	12	06-Jun-2025
Humidity & Temperature meter	R.S Components	1364	6149	12	07-Jul-2024
8 GHz Highpass Filter	Wainwright	WHKX 7150 8000 18000 50SS	6194	12	23-Apr-2025
Pre Amp 8 - 18 GHz	Wright Technologies	APS06 0061	6200	12	03-Jun-2025
Attenuator 4dB	Pasternack	PE7074-4	6201	24	24-May-2026
Cable (SMA to SMA 1m)	Junkosha	MWX221/B	6305	12	20-May-2025
Cable (SMA to SMA 8m)	Junkosha	MWX221-08000AMSAMS/B	6318	12	18-Feb-2025
Cable (SMA to SMA 8m)	Junkosha	MWX221-08000AMSAMS/B	6319	12	04-Feb-2025
Cable (K Type 2m)	Junkosha	MWX241-02000KMSKMS/B	6323	12	04-Feb-2025
EMC Test Receiver	Rohde & Schwarz	ESW44	6333	12	16-Feb-2025
8 GHz High Pass Filter	Wainwright	WHKX 7150 8000 18000 50SS	6427	12	23-Apr-2025
Trilog Super Broadband Test Antenna	Schwarzbeck	VULB 9168	6456	24	10-Feb-2025
Horn Antenna	Schwarzbeck	BBHA 9120 B	6457	12	05-May-2025
DRG Horn Antenna	Schwarzbeck	HWRD750	6458	12	05-May-2025



Instrument	Manufacturer	Type No.	TE No.	Calibration Period (months)	Calibration Expiry Date
3m Semi-Anechoic Chamber, Chamber18	Albatross Projects	Chamber 18	6597	24	22-Feb-2026
Coax cable sma to sma with N-Type adapter	TUV SUD	N/A	6637	12	24-Jul-2024
1m Cable	Junkosha	MWX241-01000AMSAMS/B	6741	12	01-Feb-2025
2m Cable	Junkosha	MWX241-02000KMSKMS/B	6742	12	01-Feb-2025
Double Ridge Active Horn Antenna (18-40 GHz)	Com-Power	AHA-840	6771	24	17-Jan-2025
Pre Amp 8 - 18 GHz	Wright Technologies	APS06-0061	6783	12	23-Apr-2025
Mast & Turntable Controller	Maturo Gmbh	FCU3.0	6795	-	TU
Tilt Antenna Mast	Maturo Gmbh	BAM4.5-P	6796	-	TU
Turntable	Maturo Gmbh	TT1.5SI	6797	-	TU

Table 144

TU - Traceability Unscheduled
 O/P Mon - Output Monitored using calibrated equipment



3 Measurement Uncertainty

For a 95% confidence level, the measurement uncertainties for defined systems are:

Test Name	Measurement Uncertainty
Restricted Band Edges	30 MHz to 1 GHz: ± 5.2 dB 1 GHz to 40 GHz: ± 6.3 dB
Frequency Hopping Systems - Average Time of Occupancy	-
Frequency Hopping Systems - Channel Separation	± 40.30 kHz
Frequency Hopping Systems - Number of Hopping Channels	-
Frequency Hopping Systems – 99% & 20 dB Bandwidth	± 45.99 kHz
Maximum Conducted Output Power	± 1.38 dB
Authorised Band Edges	30 MHz to 1 GHz: ± 5.2 dB 1 GHz to 40 GHz: ± 6.3 dB
Spurious Radiated Emissions	30 MHz to 1 GHz: ± 5.2 dB 1 GHz to 40 GHz: ± 6.3 dB

Table 145

Measurement Uncertainty Decision Rule – Accuracy Method

Determination of conformity with the specification limits is based on the decision rule according to IEC Guide 115:2021, Clause 4.4.3 (Procedure 2). The measurement results are directly compared with the test limit to determine conformance with the requirements of the standard.

Risk: The uncertainty of measurement about the measured result is negligible with regard to the final pass/fail decision. The measurement result can be directly compared with the test limit to determine conformance with the requirement (compare IEC Guide 115). The level of risk to falsely accept and falsely reject items is further described in ILAC-G8.