

FCC and ISED Test Report

Apple Inc
Model: A3204



In accordance with FCC 47 CFR Part 15C,
ISED RSS-247 and ISED RSS-GEN
(2.4 GHz Bluetooth FHSS)

Prepared for: Apple Inc
One Apple Park Way
Cupertino
California
95014
USA

FCC ID: BCGA3204

IC: 579C-A3204

COMMERCIAL-IN-CONFIDENCE

Document 75960105-04 Issue 01

SIGNATURE

NAME	JOB TITLE	RESPONSIBLE FOR	ISSUE DATE
Steven White	Senior Technical Specialist	Authorised Signatory	16 April 2024

Signatures in this approval box have checked this document in line with the requirements of TÜV SÜD document control rules.

ENGINEERING STATEMENT

The measurements shown in this report were made in accordance with the procedures described on test pages. All reported testing was carried out on a sample equipment to demonstrate limited compliance with FCC 47 CFR Part 15C, ISED RSS-247 and ISED RSS-GEN. The sample tested was found to comply with the requirements defined in the applied rules.

RESPONSIBLE FOR	NAME	DATE	SIGNATURE
Report Generation	Lauren Walters	16 April 2024	

FCC Accreditation

553713/UK2026 Concorde Park, Fareham Test Laboratory

ISED Accreditation

28798 Concorde Park, Fareham Test Laboratory

EXECUTIVE SUMMARY

A sample of this product was tested and found to be compliant with FCC 47 CFR Part 15C: 2022, ISED RSS-247: Issue 3 (08-2023) and ISED RSS-GEN: Issue 5 (04-2018) + A2 (02-2021) for the tests detailed in section 1.3.



DISCLAIMER AND COPYRIGHT

This non-binding report has been prepared by TÜV SÜD with all reasonable skill and care. The document is confidential to the potential Client and TÜV SÜD. No part of this document may be reproduced without the prior written approval of TÜV SÜD. © 2024 TÜV SÜD. This report relates only to the actual item/items tested.

ACCREDITATION

Our UKAS Accreditation does not cover opinions and interpretations and any expressed are outside the scope of our UKAS Accreditation. Results of tests not covered by our UKAS Accreditation Schedule are marked NUA (Not UKAS Accredited). Results of tests covered by our Flexible UKAS Accreditation Schedule are marked FS (Flexible Scope).

TÜV SÜD
is a trading name of TÜV SÜD Ltd
Registered in Scotland at East Kilbride,
Glasgow G75 0QF, United Kingdom
Registered number: SC215164

TÜV SÜD Ltd is a
TÜV SÜD Group Company

Phone: +44 (0) 1489 558100
Fax: +44 (0) 1489 558101
www.tuvsud.com/en

TÜV SÜD
Octagon House
Concorde Way
Fareham
Hampshire PO15 5RL
United Kingdom



Contents

1	Report Summary	2
1.1	Report Modification Record.....	2
1.2	Introduction.....	2
1.3	Brief Summary of Results	3
1.4	Product Information	4
1.5	Deviations from the Standard.....	4
1.6	Identification of the EUT	5
1.7	EUT Modification Record	5
1.8	Test Location	6
2	Test Details	7
2.1	Restricted Band Edges.....	7
2.2	Frequency Hopping Systems - Average Time of Occupancy	13
2.3	Frequency Hopping Systems - Channel Separation.....	18
2.4	Frequency Hopping Systems - Number of Hopping Channels	23
2.5	Frequency Hopping Systems - 99% & 20 dB Bandwidth.....	28
2.6	Maximum Conducted Output Power	41
2.7	Authorised Band Edges	46
2.8	Spurious Radiated Emissions	52
3	Measurement Uncertainty	60



1 Report Summary

1.1 Report Modification Record

Alterations and additions to this report will be issued to the holders of each copy in the form of a complete document.

Issue	Description of Change	Date of Issue
1	First Issue	16-April-2024

Table 1

1.2 Introduction

Applicant	Apple Inc
Manufacturer	Apple Inc
EUT/Sample Identification	Refer to section 1.6
Test Specification/Issue/Date	FCC 47 CFR Part 15C: 2022 ISED RSS-247: Issue 3 (08-2023) ISED RSS-GEN: Issue 5 (04-2018) + A2 (02-2021)
Start of Test	04-February-2024
Finish of Test	07-March-2024
Name of Engineer(s)	Elliot Callender, Nicolae Mihailiuc, Mustafa Murad, Jayvir Makwana, Jamal Imoro Abubakar and Tony Baby
Related Document(s)	ANSI C63.10 (2020)



1.3 Brief Summary of Results

A brief summary of the tests carried out in accordance with FCC 47 CFR Part 15C, ISED RSS-247 and ISED RSS-GEN is shown below.

Section	Specification Clause			Test Description	Result	Comments/Base Standard
	Part 15C	RSS-247	RSS-GEN			
Configuration and Mode: 2.4 GHz Bluetooth FHSS						
-	15.203	-	-	Antenna Requirement	N/T	The device complies with the provisions of this section, as it uses permanently attached integral antennas.
2.1	15.205	3.3	8.10	Restricted Band Edges	Pass	ANSI C63.10 (2020)
2.2	15.247 (a)(1)	5.1	-	Frequency Hopping Systems - Average Time of Occupancy	Pass	ANSI C63.10 (2020)
2.3	15.247 (a)(1)	5.1	-	Frequency Hopping Systems - Channel Separation	Pass	ANSI C63.10 (2020)
2.4	15.247 (a)(1)	5.1	-	Frequency Hopping Systems - Number of Hopping Channels	Pass	ANSI C63.10 (2020)
2.5	15.247 (a)(1)	5.1	6.7	Frequency Hopping Systems - 99% & 20 dB Bandwidth	Pass	ANSI C63.10 (2020)
2.6	15.247 (b)	5.4	6.12	Maximum Conducted Output Power	Pass	ANSI C63.10 (2020)
2.7	15.247 (d)	5.5	-	Authorised Band Edges	Pass	ANSI C63.10 (2020)
2.8	15.209 and 15.247 (d)	3.3 and 5.5	6.13 and 8.9	Spurious Radiated Emissions	Pass	ANSI C63.10 (2020)

Table 2



1.4 Product Information

1.4.1 Technical Description

The equipment under test (EUT) was a wireless mouse.

1.4.2 Test Modes

Bluetooth BDR/EDR was assessed as a FHSS system.

The EUT was tested in the following mode of operations:

- Bluetooth BDR: DH5
- Bluetooth EDR: 2-DH5 & 3-DH5

1.4.3 Test Setup

For conducted tests, a conducted test point was provided by the manufacturer via a PCB RF connector and cable. The loss of the test cable was known and compensated for in any conducted measurements.

For all tests the EUT was put into a continuous transmit or receive test mode with the manufacturer's test commands. These were sent from a script running on a test laptop connected to the EUT's USB port. The EUT then transmitted the required type of modulation and packet type on either a static channel selected within the test script, or frequency hopping over the maximum number of supported channels.

All testing was performed with the EUT powered via its internal battery.

1.4.4 Antenna Gain Table

Frequency Range (MHz)	Peak Gain (dBi)	Conducted Cable Loss (dB)
2402	-2.94	0.4
2441	-2.63	0.4
2480	-3.01	0.4

Table 3

1.5 Deviations from the Standard

No deviations from the applicable test standard were made during testing.



1.6 Identification of the EUT

The table below details identification of the EUT(s) that have been used to carry out the testing within this report.

Model: A3204			
Serial Number	Hardware Version	Software Version	Firmware
CC2H2A009C5000028E	REV1.0	2.5	-
CC2H2M001650000539	REV1.0	2.5	-

Table 4

1.7 EUT Modification Record

The table below details modifications made to the EUT during the test programme.

The modifications incorporated during each test are recorded on the appropriate test pages.

Modification State	Description of Modification still fitted to EUT	Modification Fitted By	Date Modification Fitted
Model: A3204, Serial Number: CC2H2A009C5000028E			
0	As supplied by the customer	Not Applicable	Not Applicable
Model: A3204, Serial Number: CC2H2M001650000539			
0	As supplied by the customer	Not Applicable	Not Applicable

Table 5



1.8 Test Location

TÜV SÜD conducted the following tests at our Concorde Park Test Laboratory.

Test Name	Name of Engineer(s)	Accreditation
Configuration and Mode: 2.4 GHz Bluetooth FHSS		
Restricted Band Edges	Elliot Callender and Nicolae Mihailiuc	UKAS
Frequency Hopping Systems - Average Time of Occupancy	Mustafa Murad	UKAS
Frequency Hopping Systems - Channel Separation	Mustafa Murad	UKAS
Frequency Hopping Systems - Number of Hopping Channels	Mustafa Murad	UKAS
Frequency Hopping Systems - 99% & 20 dB Bandwidth	Mustafa Murad and Jayvir Makwana	UKAS
Maximum Conducted Output Power	Mustafa Murad	UKAS
Authorised Band Edges	Elliot Callender and Nicolae Mihailiuc	UKAS
Spurious Radiated Emissions	Jamal Imoro Abubakar and Tony Baby	UKAS

Table 6

Office Address:

TÜV SÜD
Concorde Park
Concorde Way
Fareham
Hampshire
PO15 5FG
United Kingdom



2 Test Details

2.1 Restricted Band Edges

2.1.1 Specification Reference

FCC 47 CFR Part 15C, Clause 15.205
ISED RSS-247, Clause 3.3
ISED RSS-GEN, Clause 8.10

2.1.2 Equipment Under Test and Modification State

A3204, S/N: CC2H2A009C5000028E - Modification State 0

2.1.3 Date of Test

08-February-2024 to 10-February-2024

2.1.4 Test Method

This test was performed in accordance with ANSI C63.10, clause 6.10.5.

Plots for average measurements were taken in accordance with ANSI C63.10, clause 4.1.5.2.6.

These are shown for information purposes and were used to determine the worst-case measurement point. Final average measurements were then taken in accordance with ANSI C63.10, clause 4.1.4.2.2 to obtain the measurement result recorded in the test results tables.

The following conversion can be applied to convert from dB μ V/m to μ V/m:

$10^{(\text{Field Strength in dB}\mu\text{V/m}/20)}$.

2.1.5 Environmental Conditions

Ambient Temperature	21.3 - 21.7 °C
Relative Humidity	46.2 - 48.8 %



2.1.6 Test Results

2.4 GHz Bluetooth FHSS

iPA - Core 0 (SISO)

Mode	Packet Type	TX Frequency (MHz)	Band Edge Frequency (MHz)	Peak Level (dBμV/m)	Average Level (dBμV/m)
Static	DH5	2402	2390	54.47	41.42
Static	2-DH5	2402	2390	55.03	40.76
Static	3-DH5	2402	2390	54.88	40.78
Static	DH5	2480	2483.5	53.93	42.87
Static	2-DH5	2480	2483.5	54.06	41.45
Static	3-DH5	2480	2483.5	53.28	41.47

Table 7 - SISO Restricted Band Edge Results

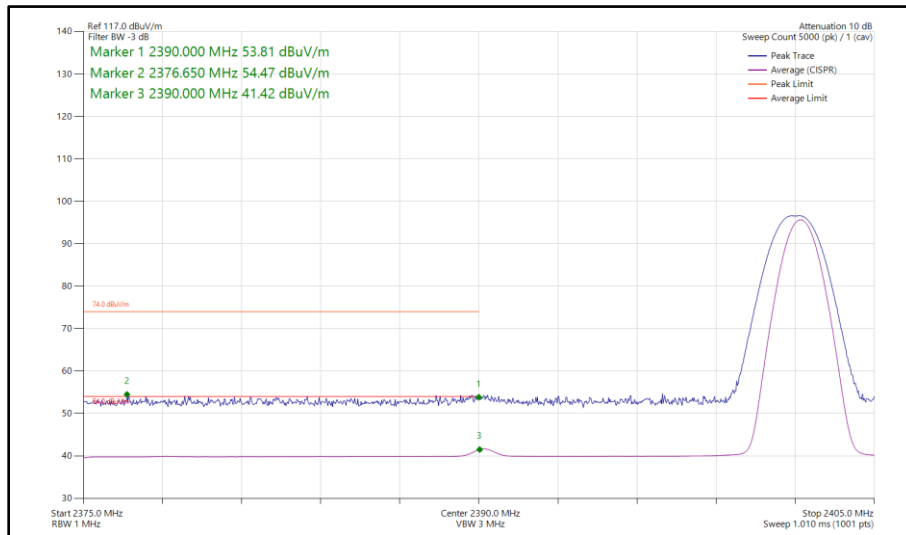

**Figure 1 - Bluetooth DH5, SISO, Core 0 - 2402 MHz
 Band Edge Frequency 2390 MHz**

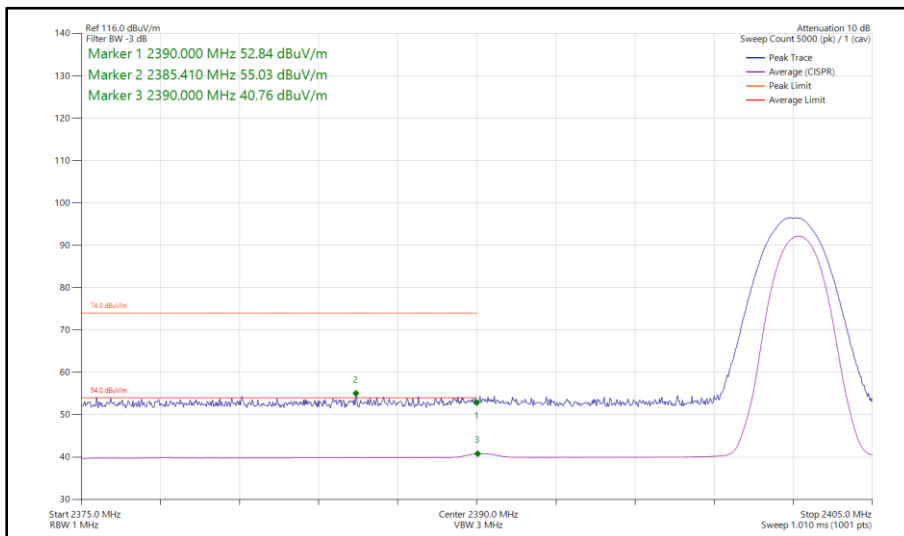

**Figure 2 - Bluetooth 2-DH5, SISO, Core 0 - 2402 MHz
Band Edge Frequency 2390 MHz**

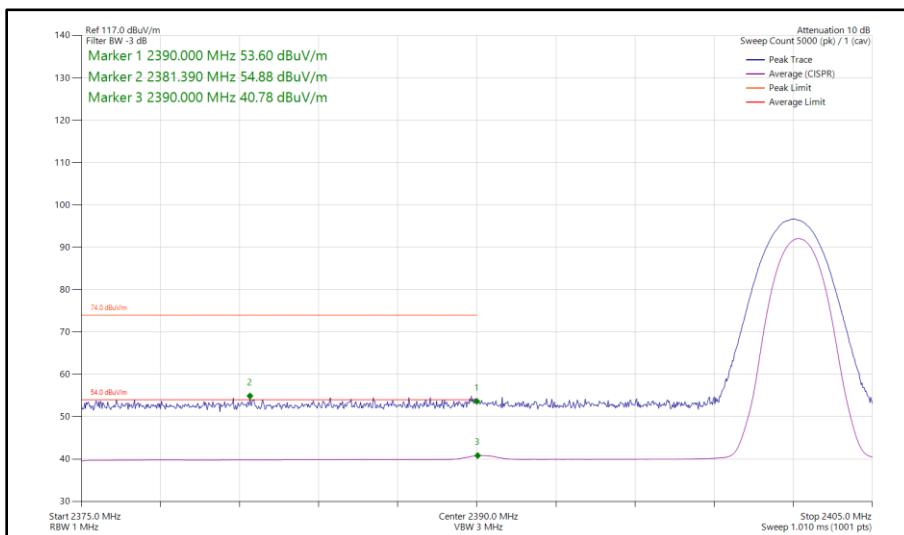

**Figure 3 - Bluetooth 3-DH5, SISO, Core 0 - 2402 MHz
Band Edge Frequency 2390 MHz**

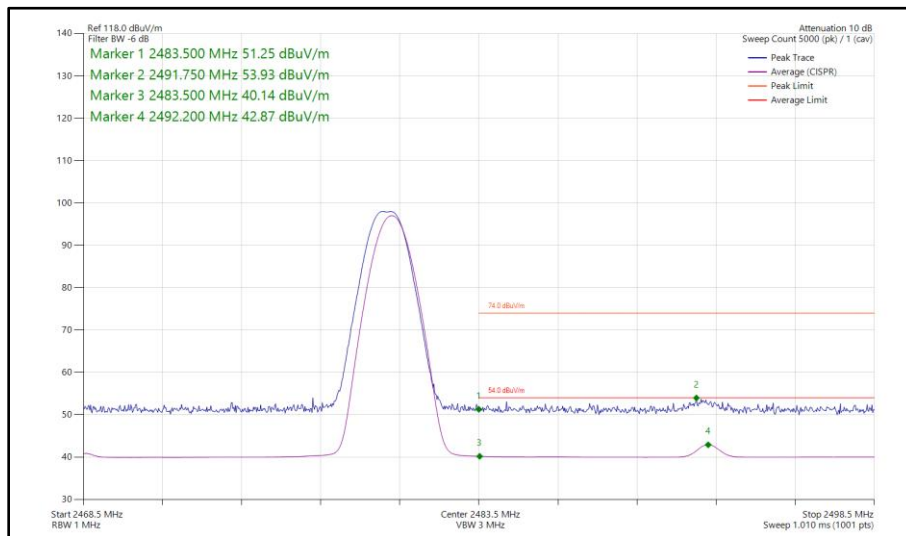

**Figure 4 - Bluetooth DH5, SISO, Core 0 - 2480 MHz
Band Edge Frequency 2483.5 MHz**

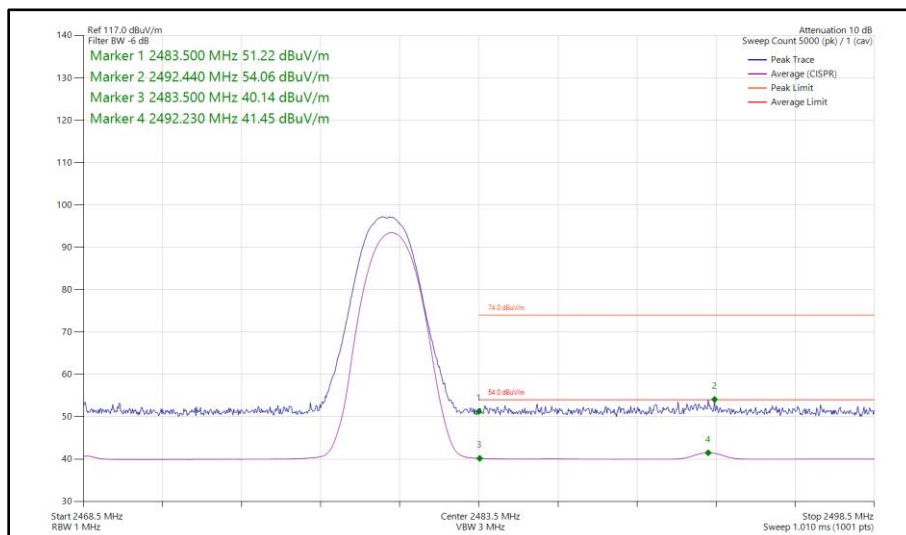

**Figure 5 - Bluetooth 2-DH5, SISO, Core 0 - 2480 MHz
Band Edge Frequency 2483.5 MHz**

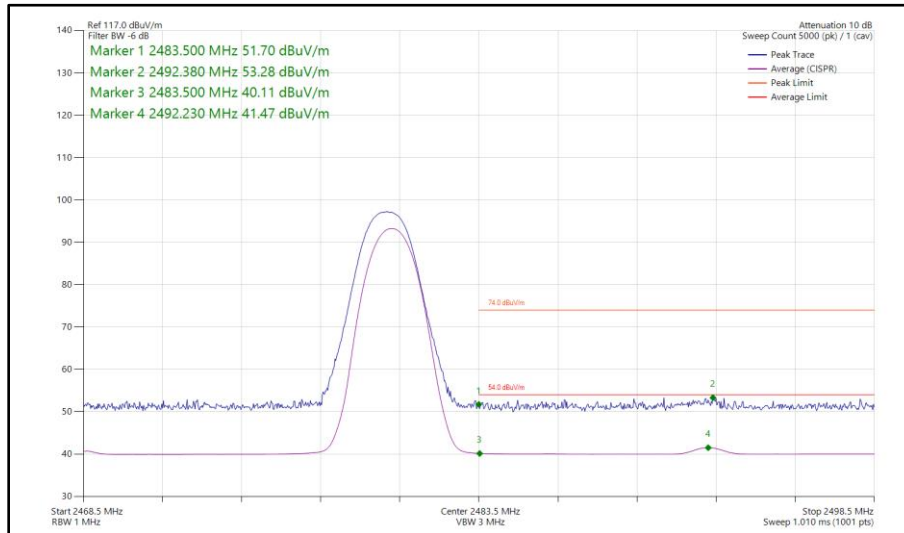

**Figure 6 - Bluetooth 3-DH5, SISO, Core 0 - 2480 MHz
 Band Edge Frequency 2483.5 MHz**

FCC 47 CFR Part 15, Limit Clause 15.209

Frequency (MHz)	Field Strength ($\mu\text{V}/\text{m}$ at 3 m)
30 to 88	100
88 to 216	150
216 to 960	200
Above 960	500

Table 8

ISED RSS-GEN, Limit Clause 8.9

Frequency (MHz)	Field Strength ($\mu\text{V}/\text{m}$ at 3 m)
30 to 88	100
88 to 216	150
216 to 960	200
Above 960*	500

Table 9

*Unless otherwise specified, for all frequencies greater than 1 GHz, the radiated emission limits for licence-exempt radio apparatus stated in applicable RSSs (including RSS-Gen) are based on measurements using a linear average detector function having a minimum resolution bandwidth of 1 MHz. If an average limit is specified for the EUT, then the peak emission shall also be measured with instrumentation properly adjusted for such factors as pulse desensitization to ensure the peak emission is less than 20 dB above the average limit.



2.1.7 Test Location and Test Equipment Used

This test was carried out in RF Chamber 16.

Instrument	Manufacturer	Type No.	TE No.	Calibration Period (months)	Calibration Expiry Date
Emissions Software	TUV SUD	EmX V3.2.0	5125	-	Software
1500W (300V 12A) AC Power Supply	iTech	IT7324	5957	-	O/P Mon
3m Semi-Anechoic Chamber, Chamber16	Albatross Projects	RF Chamber 16	5972	36	24-May-2025
Mast & Turntable Controller	Maturo Gmbh	FCU3.0	5973	-	TU
Tilt Antenna Mast	Maturo Gmbh	BAM4.5-P	5974	-	TU
Turntable	Maturo Gmbh	TT1.5SI	5975	-	TU
Cable (SMA to SMA 1m)	Junkosha	MWX221-01000AMSAMS/A	6018	12	05-Jun-2024
Horn Antenna (1-10 GHz)	Schwarzbeck	BBHA9120B	6140	12	26-Aug-2024
Horn Antenna (1-10 GHz)	Schwarzbeck	BBHA9120B	6142	12	26-Aug-2024
Digital Multimeter	Fluke	115	6146	12	15-Jun-2024
Humidity & Temperature meter	R.S Components	1364	6148	12	21-Jul-2024
SAC Switch Unit	TUV SUD	TUV_SSU_001	6190	12	22-Dec-2024
EMI Test Receiver	Rohde & Schwarz	ESW44	6294	12	29-Nov-2024
Cable (SMA to SMA 8m)	Junkosha	MWX221-08000AMSAMS/B	6318	12	12-Feb-2024

Table 10

TU - Traceability Unscheduled
 O/P Mon - Output Monitored using calibrated equipment



2.2 Frequency Hopping Systems - Average Time of Occupancy

2.2.1 Specification Reference

FCC 47 CFR Part 15C, Clause 15.247 (a)(1)
ISED RSS-247, Clause 5.1

2.2.2 Equipment Under Test and Modification State

A3204, S/N: CC2H2M001650000539 - Modification State 0

2.2.3 Date of Test

21-February-2024

2.2.4 Test Method

The test was performed in accordance with ANSI C63.10, clause 7.8.4.

2.2.5 Environmental Conditions

Ambient Temperature	21.6 °C
Relative Humidity	48.4 %



2.2.6 Test Results

2.4 GHz Bluetooth FHSS

Test Configuration			
Frequency Range:	2400-2483.5 MHz	Band:	2.4 GHz
Limit Clause(s):	FCC 15.247 (a)(1)(iii) RSS-247 5.1 d)	Test Method(s):	C63.10 7.8.4
Additional Reference(s):	-		

DUT Configuration			
Mode:	iPA GFSK (DH5)	Duty Cycle (%):	76.7
Antenna Configuration:	SISO	DCCF (dB):	-
Active Port(s):	A (Core 0)	Peak Antenna Gain (dBi):	-

Test Frequency (MHz)	Time of Occupancy			Limit (ms)
	Dwell Time (ms)	Number of Transmissions	Time of Occupancy (ms)	
2402	2.903	111	322.2	400.0

Table 11 - Time of Occupancy Results

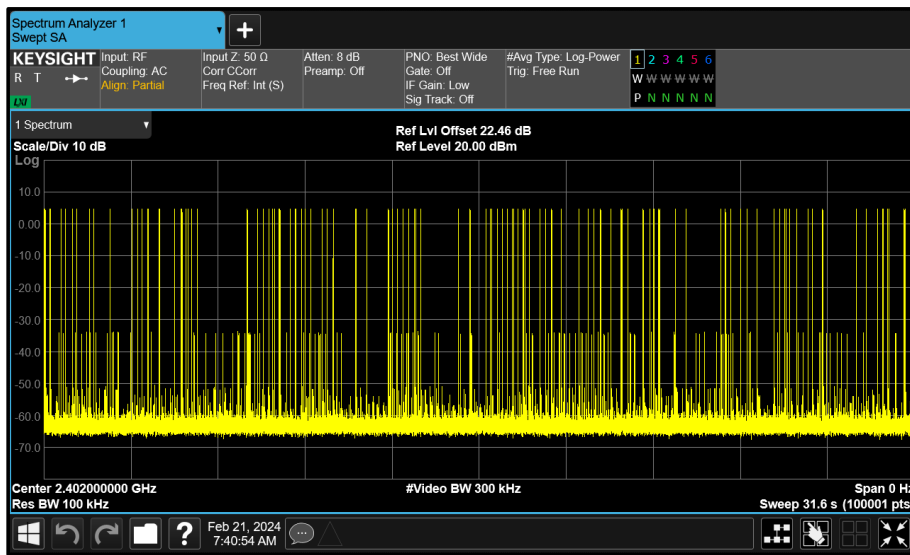

Figure 7 - GFSK - 2402 MHz Accumulated Transmit Time



Test Configuration			
Frequency Range:	2400-2483.5 MHz	Band:	2.4 GHz
Limit Clause(s):	FCC 15.247 (a)(1)(iii) RSS-247 5.1 d)	Test Method(s):	C63.10 7.8.4
Additional Reference(s):	-		

DUT Configuration			
Mode:	iPA $\pi/4$ DQPSK (2-DH5)	Duty Cycle (%):	77.1
Antenna Configuration:	SISO	DCCF (dB):	-
Active Port(s):	A (Core 0)	Peak Antenna Gain (dBi):	-

Test Frequency (MHz)	Time of Occupancy			Limit (ms)
	Dwell Time (ms)	Number of Transmissions	Time of Occupancy (ms)	
2402	2.908	101	293.7	400.0

Table 12 - Time of Occupancy Results

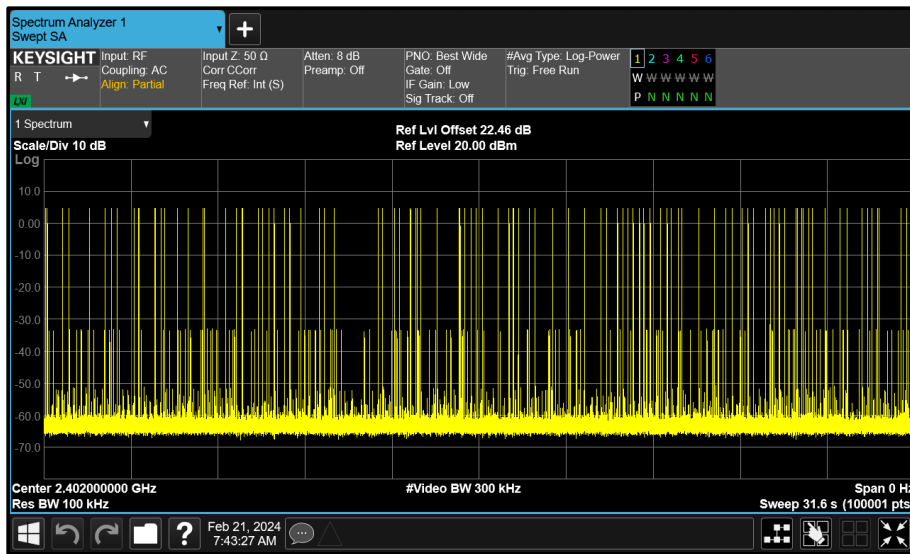

Figure 8 - $\pi/4$ DQPSK - 2402 MHz Accumulated Transmit Time



Test Configuration			
Frequency Range:	2400-2483.5 MHz	Band:	2.4 GHz
Limit Clause(s):	FCC 15.247 (a)(1)(iii) RSS-247 5.1 d)	Test Method(s):	C63.10 7.8.4
Additional Reference(s):	-		

DUT Configuration			
Mode:	iPA 8-DPSK (3-DH5)	Duty Cycle (%):	76.9
Antenna Configuration:	SISO	DCCF (dB):	-
Active Port(s):	A (Core 0)	Peak Antenna Gain (dBi):	-

Test Frequency (MHz)	Time of Occupancy			Limit (ms)
	Dwell Time (ms)	Number of Transmissions	Time of Occupancy (ms)	
2402	2.902	116	336.7	400.0

Table 13 - Time of Occupancy Results

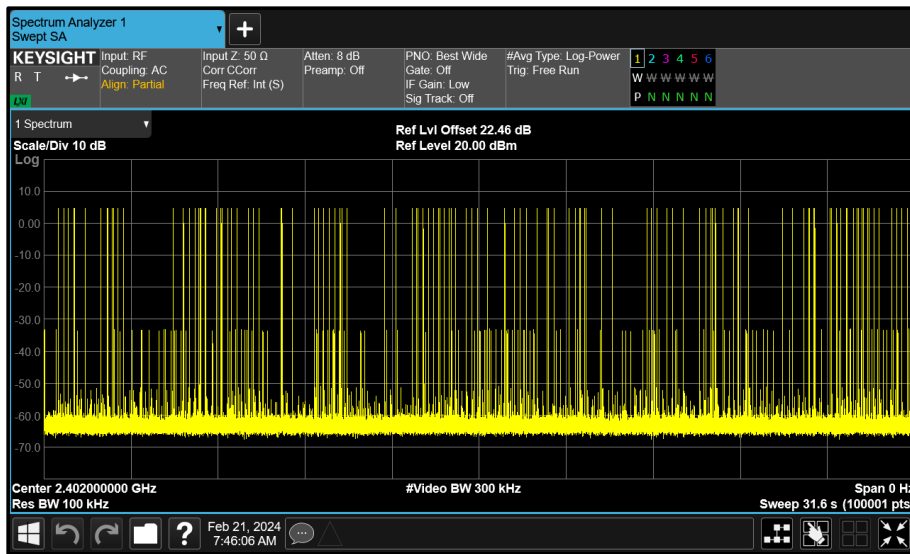

Figure 9 - 8-DPSK - 2402 MHz Accumulated Transmit Time

FCC 47 CFR Part 15, Limit Clause 15.247 (a)(1)(iii)

Frequency hopping systems operating in the band 2400-2483.5 MHz shall use at least 15 hopping channels. The average time of occupancy on any channel shall not be greater than 0.4 seconds within a period of 0.4 seconds multiplied by the number of hopping channels employed. Transmissions on particular hopping frequencies may be avoided or suppressed provided that a minimum of 15 hopping channels are used.

Industry Canada RSS-247, Limit Clause 5.1 (d)

The average time of occupancy on any channel shall not be greater than 0.4 seconds within a period of 0.4 seconds, multiplied by the number of hopping channels employed.



2.2.7 Test Location and Test Equipment Used

This test was carried out in RF Laboratory 14.

Instrument	Manufacturer	Type No.	TE No.	Calibration Period (months)	Calibration Expiry Date
MXA Signal Analyser	Keysight Technologies	N9020B	5529	24	13-Dec-2024
Digital Multimeter	Fluke	115	6145	12	15-Jun-2024
Humidity and Temperature Meter	R.S Components	1364	6346	12	28-Feb-2024
Signal Conditioning Unit	TUV SUD	SPECTRUM_SCU001	6426	12	07-Feb-2025

Table 14



2.3 Frequency Hopping Systems - Channel Separation

2.3.1 Specification Reference

FCC 47 CFR Part 15C, Clause 15.247 (a)(1)
ISED RSS-247, Clause 5.1

2.3.2 Equipment Under Test and Modification State

A3204, S/N: CC2H2M001650000539 - Modification State 0

2.3.3 Date of Test

21-February-2024

2.3.4 Test Method

The test was performed in accordance with ANSI C63.10, clause 7.8.2.

2.3.5 Environmental Conditions

Ambient Temperature	21.6 °C
Relative Humidity	48.4 %



2.3.6 Test Results

2.4 GHz Bluetooth FHSS

Test Configuration			
Frequency Range:	2400-2483.5 MHz	Band:	2.4 GHz
Limit Clause(s):	FCC 15.247(a)(1) RSS-247 5.1 b)	Test Method(s):	C63.10 7.8.2
Additional Reference(s):	-		

DUT Configuration			
Mode:	iPA GFSK (DH5)	Duty Cycle (%):	-
Antenna Configuration:	SISO	DCCF (dB):	-
Active Port(s):	A (Core 0)	Peak Antenna Gain (dBi):	-

Test Frequency (MHz)	20 dB Bandwidth (MHz)	Carrier Frequency Separation (MHz)			Limit (kHz)
		F1C	F2C	FHS	
2441	1.013	2441.003	2442.005	1.002	≥675.2

Table 15 - Carrier Frequency Separation Results

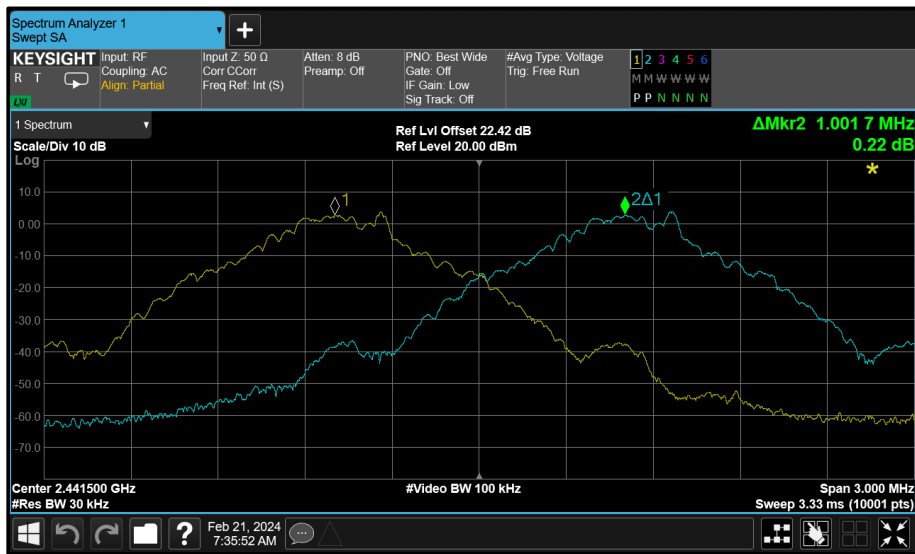

Figure 10 - GFSK - 2441 MHz (CH39)



Test Configuration			
Frequency Range:	2400-2483.5 MHz	Band:	2.4 GHz
Limit Clause(s):	FCC 15.247(a)(1) RSS-247 5.1 b)	Test Method(s):	C63.10 7.8.2
Additional Reference(s):	-		

DUT Configuration			
Mode:	iPA $\pi/4$ DQPSK (2-DH5)	Duty Cycle (%):	-
Antenna Configuration:	SISO	DCCF (dB):	-
Active Port(s):	A (Core 0)	Peak Antenna Gain (dBi):	-

Test Frequency (MHz)	20 dB Bandwidth (MHz)	Carrier Frequency Separation (MHz)			Limit (kHz)
		F1C	F2C	FHS	
2441	1.281	2441.013	2442.013	1.000	≥ 854.1

Table 16 - Carrier Frequency Separation Results

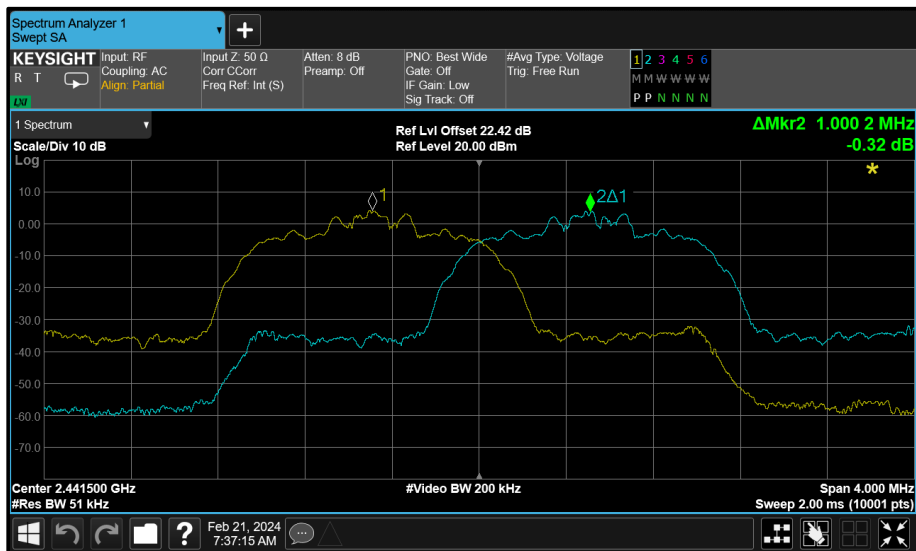

Figure 11 - $\pi/4$ DQPSK - 2441 MHz (CH39)



Test Configuration			
Frequency Range:	2400-2483.5 MHz	Band:	2.4 GHz
Limit Clause(s):	FCC 15.247(a)(1) RSS-247 5.1 b)	Test Method(s):	C63.10 7.8.2
Additional Reference(s):	-		

DUT Configuration			
Mode:	iPA 8-DPSK (3-DH5)	Duty Cycle (%):	-
Antenna Configuration:	SISO	DCCF (dB):	-
Active Port(s):	A (Core 0)	Peak Antenna Gain (dBi):	-

Test Frequency (MHz)	20 dB Bandwidth (MHz)	Carrier Frequency Separation (MHz)			Limit (kHz)
		F1C	F2C	FHS	
2441	1.283	2441.010	2442.012	1.002	≥855.5

Table 17 - Carrier Frequency Separation Results



Figure 12 - 8-DPSK - 2441 MHz (CH39)



FCC 47 CFR Part 15, Limit Clause 15.247 (a)(1)

Frequency hopping systems shall have hopping channel carrier frequencies separated by a minimum of 25 kHz or the 20 dB bandwidth of the hopping channel, whichever is greater.

Alternatively, frequency hopping systems operating in the band 2400-2483.5 MHz may have hopping channel carrier frequencies that are separated by 25 kHz or two-thirds of the 20 dB bandwidth of the hopping channel, whichever is greater, provided the systems operate with an output power no greater than 0.125 W.

ISED RSS-247, Limit Clause 5.1 (b)

FHSs shall have hopping channel carrier frequencies separated by a minimum of 25 kHz or the -20 dB bandwidth of the hopping channel, whichever is greater. Alternatively, FHSs operating in the band 2400-2483.5 MHz may have hopping channel carrier frequencies that are separated by 25 kHz or two thirds of the 20 dB bandwidth of the hopping channel, whichever is greater, provided that the systems operate with an output power no greater than 0.125 W.

2.3.7 Test Location and Test Equipment Used

This test was carried out in RF Laboratory 14.

Instrument	Manufacturer	Type No.	TE No.	Calibration Period (months)	Calibration Expiry Date
MXA Signal Analyser	Keysight Technologies	N9020B	5529	24	13-Dec-2024
Digital Multimeter	Fluke	115	6145	12	15-Jun-2024
Humidity and Temperature Meter	R.S Components	1364	6346	12	28-Feb-2024
Signal Conditioning Unit	TUV SUD	SPECTRUM_SCU001	6426	12	07-Feb-2025

Table 18



2.4 Frequency Hopping Systems - Number of Hopping Channels

2.4.1 Specification Reference

FCC 47 CFR Part 15C, Clause 15.247 (a)(1)
ISED RSS-247, Clause 5.1

2.4.2 Equipment Under Test and Modification State

A3204, S/N: CC2H2M001650000539 - Modification State 0

2.4.3 Date of Test

21-February-2024

2.4.4 Test Method

The test was performed in accordance with ANSI C63.10, clause 7.8.3.

2.4.5 Environmental Conditions

Ambient Temperature	21.6 °C
Relative Humidity	48.4 %



2.4.6 Test Results

2.4 GHz Bluetooth FHSS

Test Configuration			
Frequency Range:	2400-2483.5 MHz	Band:	2.4 GHz
Limit Clause(s):	FCC 15.247(a)(1)(iii) RSS-247 5.1 d)	Test Method(s):	C63.10 7.8.3
Additional Reference(s):	-		

DUT Configuration			
Mode:	iPA GFSK (DH5)	Duty Cycle (%):	-
Antenna Configuration:	SISO	DCCF (dB):	-
Active Port(s):	A (Core 0)	Peak Antenna Gain (dBi):	-

Number of Hopping Frequencies	Limit
79	≥15.0

Table 19 - Number of Hopping Frequencies Results

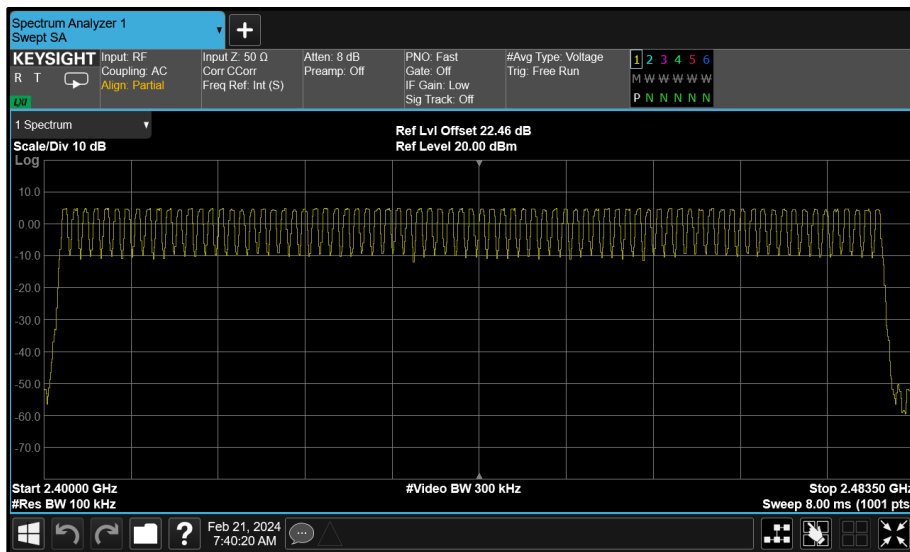

Figure 13 - GFSK (DH5) - Number of Hopping Channels



Test Configuration			
Frequency Range:	2400-2483.5 MHz	Band:	2.4 GHz
Limit Clause(s):	FCC 15.247(a)(1)(iii) RSS-247 5.1 d)	Test Method(s):	C63.10 7.8.3
Additional Reference(s):	-		

DUT Configuration			
Mode:	iPA $\pi/4$ DQPSK (2-DH5)	Duty Cycle (%):	-
Antenna Configuration:	SISO	DCCF (dB):	-
Active Port(s):	A (Core 0)	Peak Antenna Gain (dBi):	-

Number of Hopping Frequencies	Limit
79	≥ 15.0

Table 20 - Number of Hopping Frequencies Results

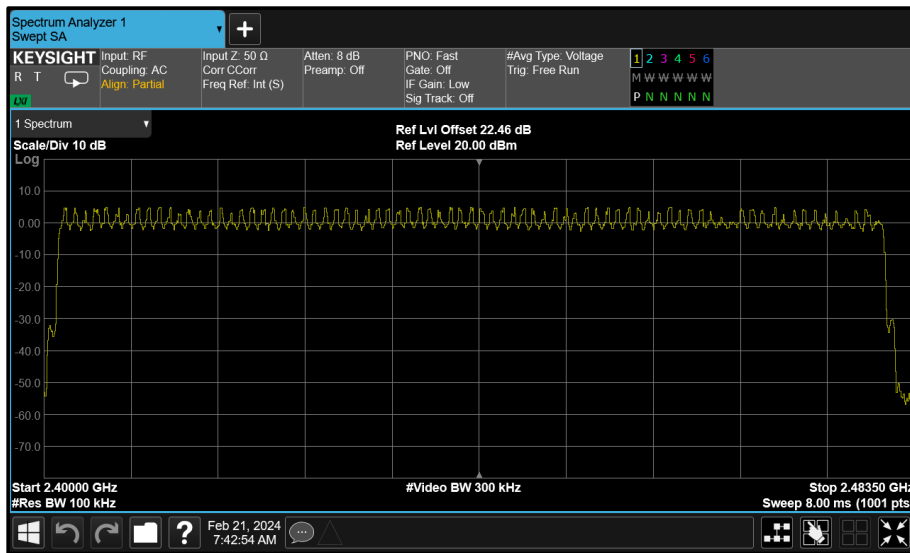

Figure 14 - $\pi/4$ DQPSK (2-DH5) - Number of Hopping Channels



Test Configuration			
Frequency Range:	2400-2483.5 MHz	Band:	2.4 GHz
Limit Clause(s):	FCC 15.247(a)(1)(iii) RSS-247 5.1 d)	Test Method(s):	C63.10 7.8.3
Additional Reference(s):	-		

DUT Configuration			
Mode:	iPA 8-DPSK (3-DH5)	Duty Cycle (%):	-
Antenna Configuration:	SISO	DCCF (dB):	-
Active Port(s):	A (Core 0)	Peak Antenna Gain (dBi):	-

Number of Hopping Frequencies	Limit
79	≥15.0

Table 21 - Number of Hopping Frequencies Results

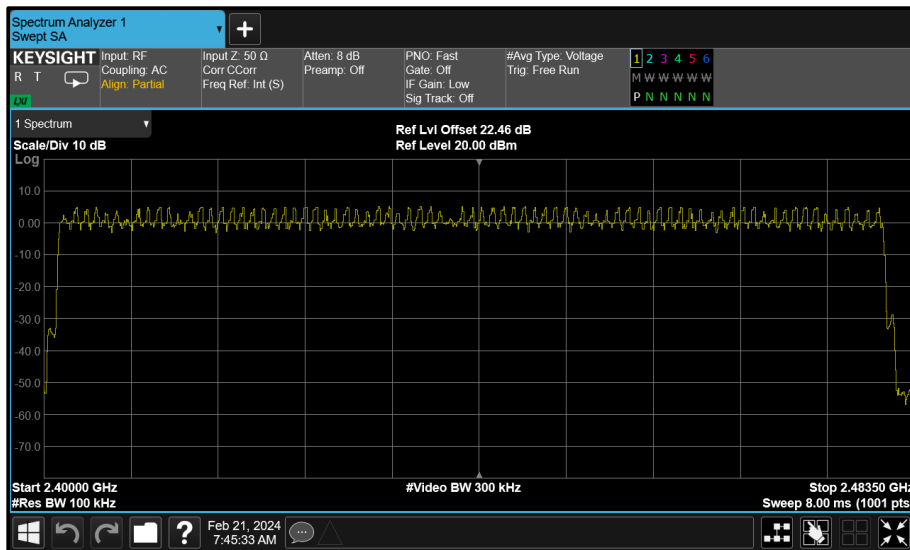

Figure 15 - 8-DPSK (3-DH5) - Number of Hopping Channels

FCC 47 CFR Part 15, Limit Clause 15.247 (a)(1)(iii)

≥ 15 channels

ISED RSS-247, Limit Clause 5.1 (d)

FHSs operating in the band 2400-2483.5 MHz shall use at least 15 hopping channels.



2.4.7 Test Location and Test Equipment Used

This test was carried out in RF Laboratory 14.

Instrument	Manufacturer	Type No.	TE No.	Calibration Period (months)	Calibration Expiry Date
MXA Signal Analyser	Keysight Technologies	N9020B	5529	24	13-Dec-2024
Digital Multimeter	Fluke	115	6145	12	15-Jun-2024
Humidity and Temperature Meter	R.S Components	1364	6346	12	28-Feb-2024
Signal Conditioning Unit	TUV SUD	SPECTRUM_SCU001	6426	12	07-Feb-2025

Table 22



2.5 Frequency Hopping Systems - 99% & 20 dB Bandwidth

2.5.1 Specification Reference

FCC 47 CFR Part 15C, Clause 15.247 (a)(1)
ISED RSS-247, Clause 5.1
ISED RSS-GEN, Clause 6.7

2.5.2 Equipment Under Test and Modification State

A3204, S/N: CC2H2M001650000539 - Modification State 0

2.5.3 Date of Test

21-February-2024 to 07-March-2024

2.5.4 Test Method

The test was performed in accordance with ANSI C63.10, clause 6.9.3 and 6.9.2.

2.5.5 Environmental Conditions

Ambient Temperature	22.1 - 23.8°C
Relative Humidity	42.1 - 46.5 %



2.5.6 Test Results

2.4 GHz Bluetooth FHSS

Test Configuration			
Frequency Range:	2400-2483.5 MHz	Band:	2.4 GHz
Limit Clause(s):	FCC 15.247 (a)(1) RSS-247 5.1	Test Method(s):	C63.10 6.9.2 C63.10 6.9.3
Additional Reference(s):	-		

DUT Configuration			
Mode:	iPA GFSK (DH5)	Duty Cycle (%):	-
Antenna Configuration:	SISO	DCCF (dB):	-
Active Port(s):	A (Core 0)	Peak Antenna Gain (dBi):	-

Test Frequency (MHz)	20 dB Bandwidth (MHz)			
	A	B	C	D
2402	0.993	-	-	-
2441	0.954	-	-	-
2480	0.948	-	-	-

Table 23 - 20 dB Bandwidth Results

Test Frequency (MHz)	99% Bandwidth (MHz)				Limit (kHz)
	A	B	C	D	
2402	0.888	-	-	-	-
2441	0.885	-	-	-	-
2480	0.880	-	-	-	-

Table 24 - 99% Bandwidth Results

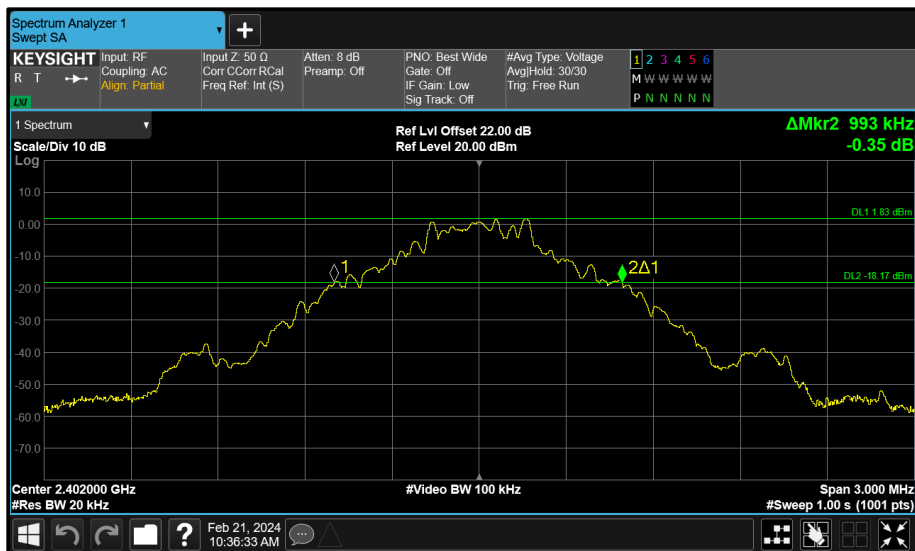

Figure 16 - Core 0 (A) 2402 MHz (CH0) 20 dB Bandwidth

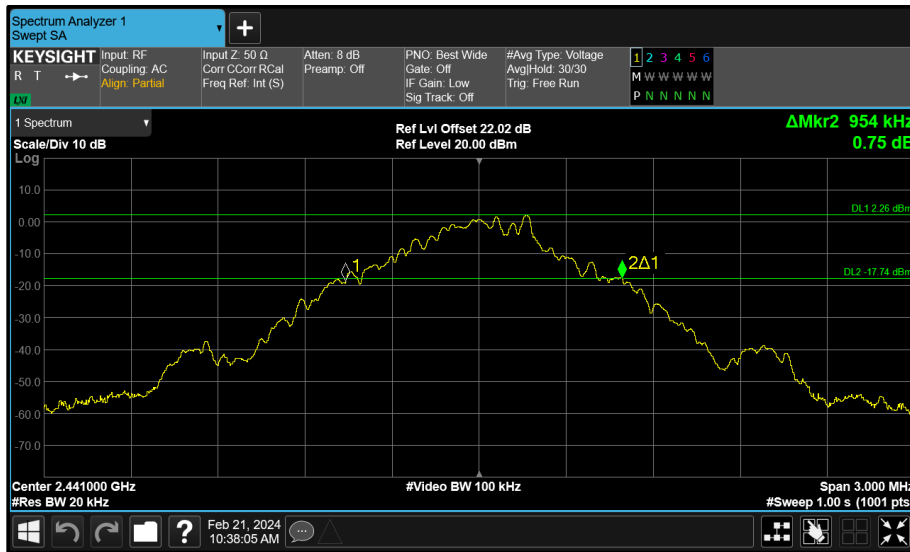

Figure 17 - Core 0 (A) 2441 MHz (CH39) 20 dB Bandwidth

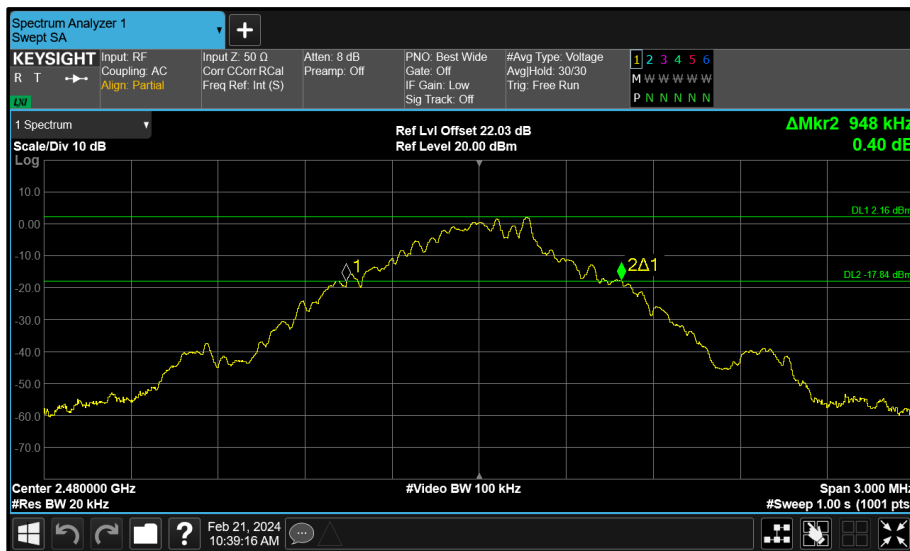

Figure 18 - Core 0 (A) 2480 MHz (CH78) 20 dB Bandwidth

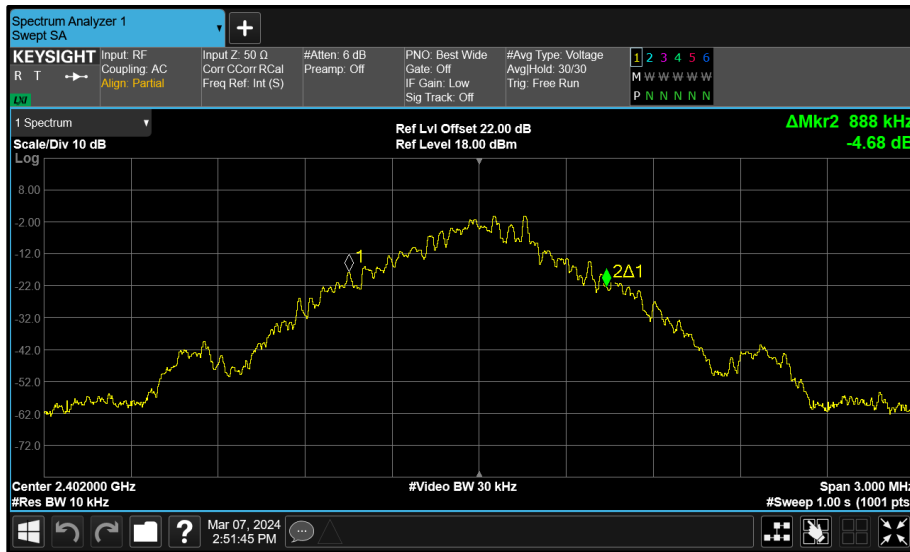

Figure 19 - Core 0 (A) 2402 MHz (CH0) 99% Bandwidth

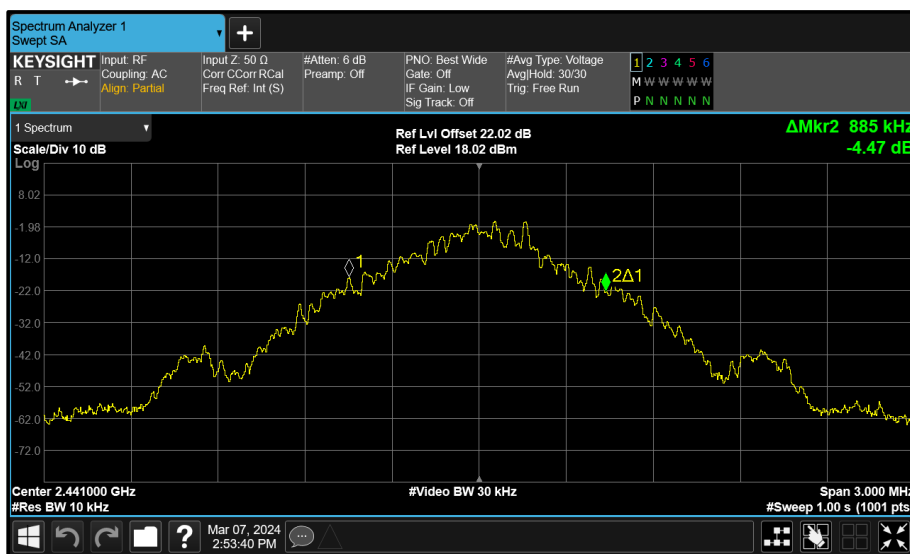

Figure 20 - Core 0 (A) 2441 MHz (CH39) 99% Bandwidth

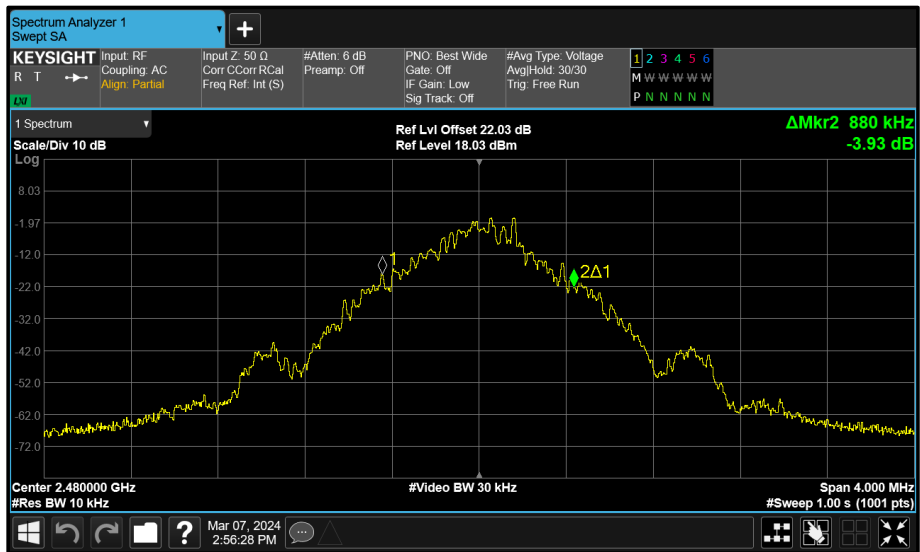

Figure 21 - Core 0 (A) 2480 MHz (CH78) 99% Bandwidth



Test Configuration			
Frequency Range:	2400-2483.5 MHz	Band:	2.4 GHz
Limit Clause(s):	FCC 15.247 (a)(1) RSS-247 5.1	Test Method(s):	C63.10 6.9.2 C63.10 6.9.3
Additional Reference(s):	-		

DUT Configuration			
Mode:	iPA $\pi/4$ DQPSK (2-DH5)	Duty Cycle (%):	-
Antenna Configuration:	SISO	DCCF (dB):	-
Active Port(s):	A (Core 0)	Peak Antenna Gain (dBi):	-

Test Frequency (MHz)	20 dB Bandwidth (MHz)			
	A	B	C	D
2402	1.255	-	-	-
2441	1.260	-	-	-
2480	1.250	-	-	-

Table 25 - 20 dB Bandwidth Results

Test Frequency (MHz)	99% Bandwidth (MHz)				Limit (kHz)
	A	B	C	D	
2402	1.160	-	-	-	-
2441	1.164	-	-	-	-
2480	1.168	-	-	-	-

Table 26 - 99% Bandwidth Results



Figure 22 - Core 0 (A) 2402 MHz (CH0) 20 dB Bandwidth

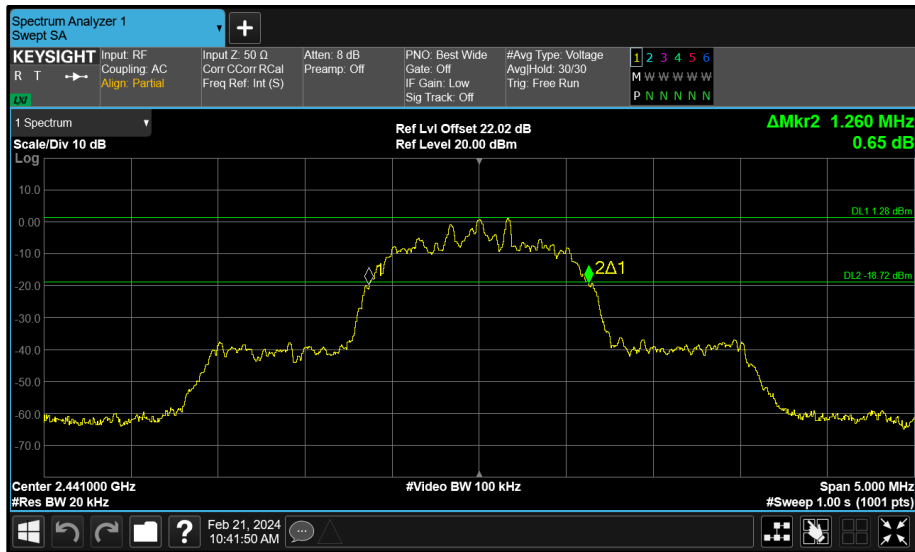

Figure 23 - Core 0 (A) 2441 MHz (CH39) 20 dB Bandwidth

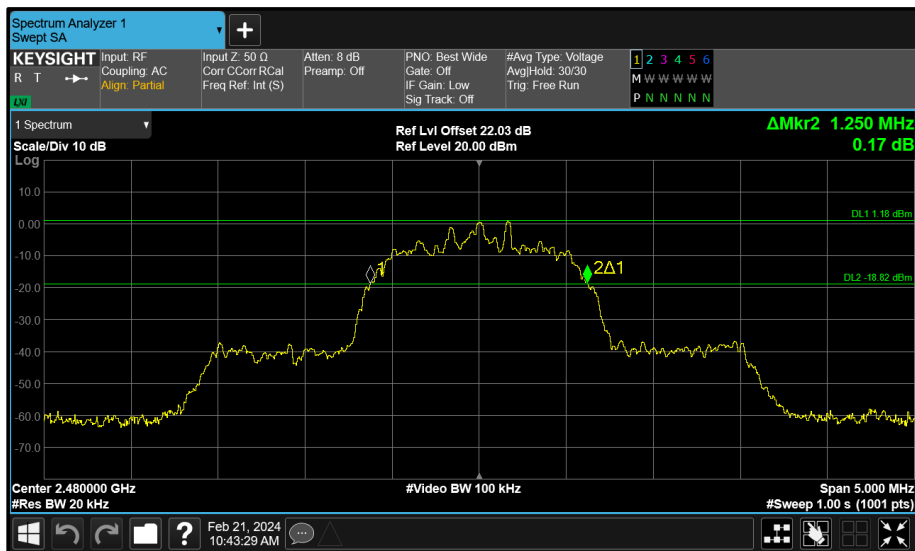

Figure 24 - Core 0 (A) 2480 MHz (CH78) 20 dB Bandwidth

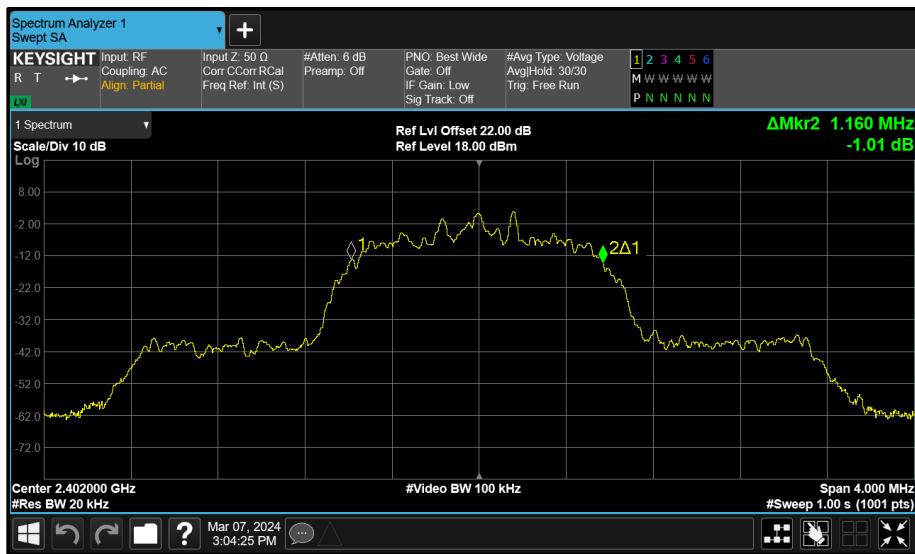

Figure 25 - Core 0 (A) 2402 MHz (CH0) 99% Bandwidth

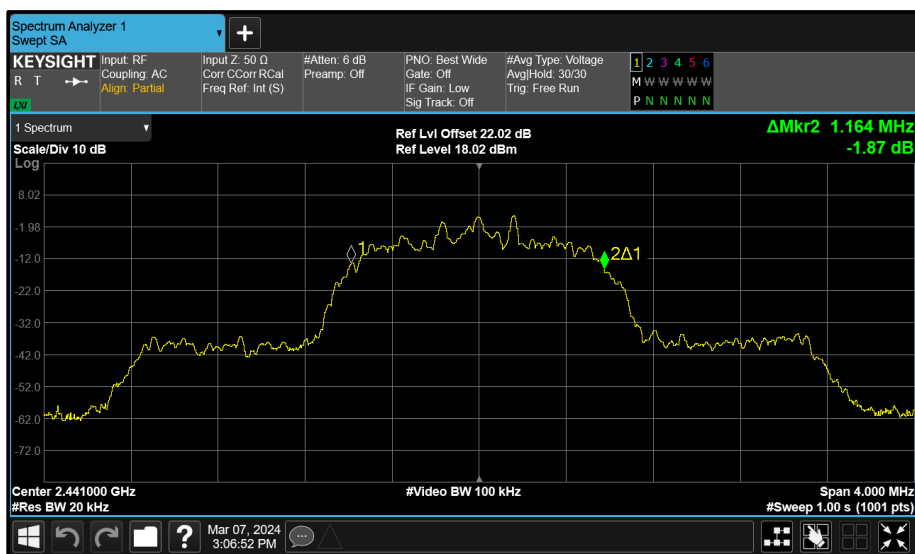

Figure 26 - Core 0 (A) 2441 MHz (CH39) 99% Bandwidth

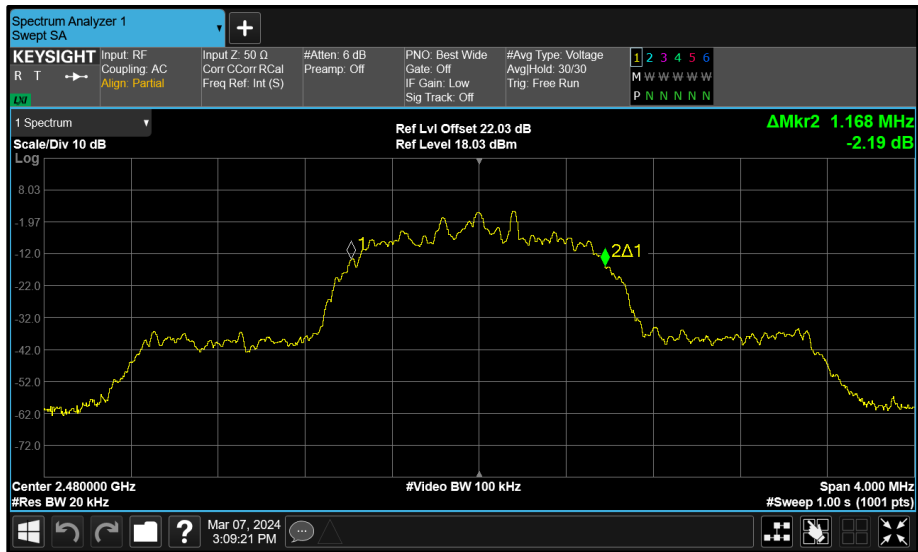

Figure 27 - Core 0 (A) 2480 MHz (CH78) 99% Bandwidth



Test Configuration			
Frequency Range:	2400-2483.5 MHz	Band:	2.4 GHz
Limit Clause(s):	FCC 15.247 (a)(1) RSS-247 5.1	Test Method(s):	C63.10 6.9.2 C63.10 6.9.3
Additional Reference(s):	-		

DUT Configuration			
Mode:	iPA 8-DPSK (3-DH5)	Duty Cycle (%):	-
Antenna Configuration:	SISO	DCCF (dB):	-
Active Port(s):	A (Core 0)	Peak Antenna Gain (dBi):	-

Test Frequency (MHz)	20 dB Bandwidth (MHz)			
	A	B	C	D
2402	1.245	-	-	-
2441	1.245	-	-	-
2480	1.250	-	-	-

Table 27 - 20 dB Bandwidth Results

Test Frequency (MHz)	99% Bandwidth (MHz)				Limit (kHz)
	A	B	C	D	
2402	1.160	-	-	-	-
2441	1.168	-	-	-	-
2480	1.164	-	-	-	-

Table 28 - 99% Bandwidth Results

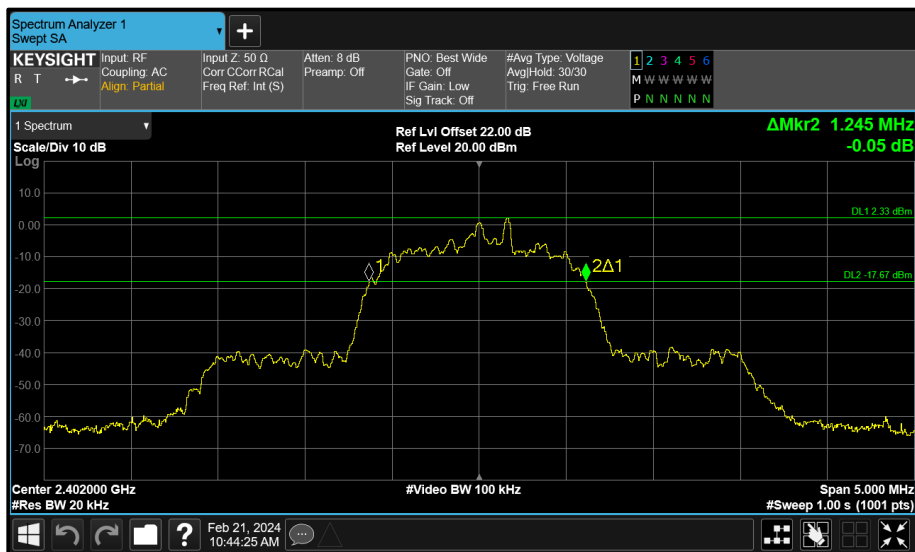

Figure 28 - Core 0 (A) 2402 MHz (CH0) 20 dB Bandwidth

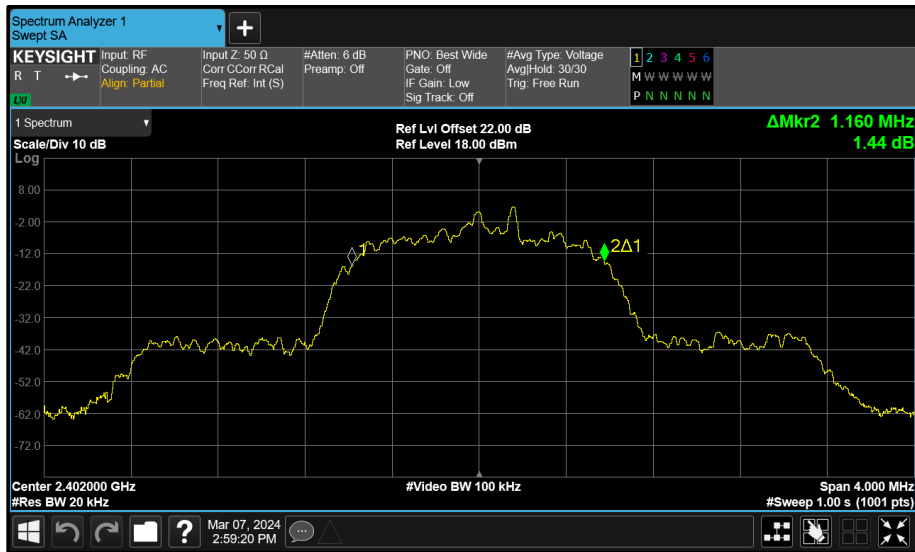

Figure 31 - Core 0 (A) 2402 MHz (CH0) 99% Bandwidth

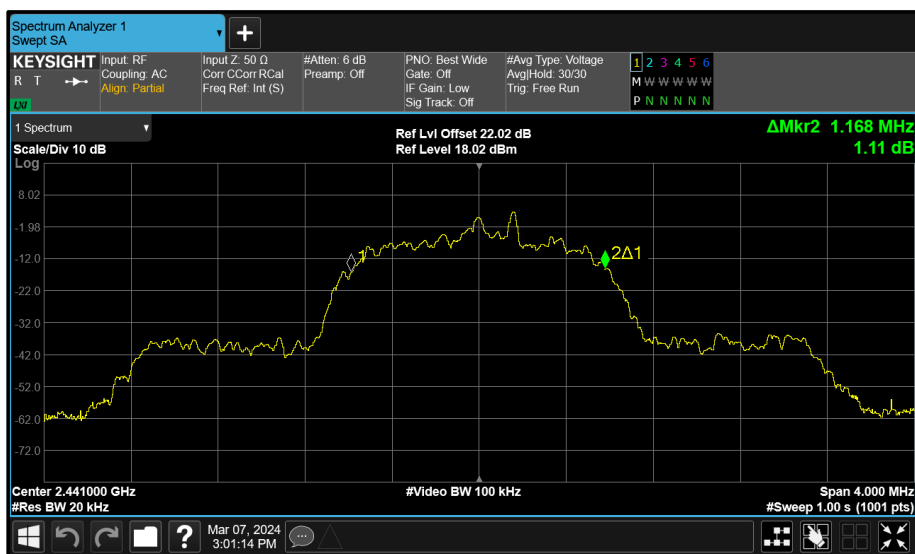

Figure 32 - Core 0 (A) 2441 MHz (CH39) 99% Bandwidth

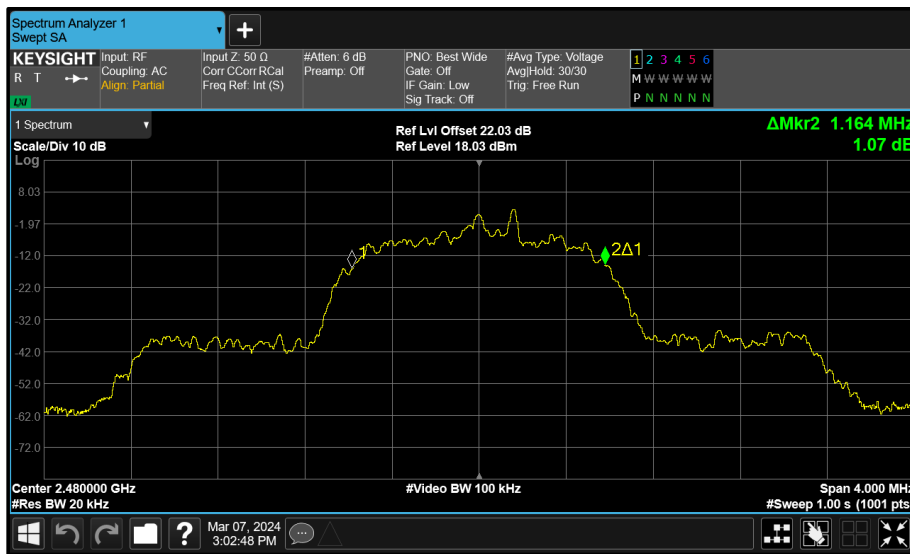

Figure 33 - Core 0 (A) 2480 MHz (CH78) 99% Bandwidth

FCC 47 CFR Part 15 and ISED RSS-247 Limit Clause

None specified.

2.5.7 Test Location and Test Equipment Used

This test was carried out in RF Chamber 18.

Instrument	Manufacturer	Type No.	TE No.	Calibration Period (months)	Calibration Expiry Date
Digital Multimeter	Fluke	115	6145	12	15-Jun-2024
Humidity and Temperature Meter	R.S Components	1364	6346	12	28-Feb-2024
MXA Signal Analyser	Keysight Technologies	N9020B	6417	24	26-Feb-2025
Signal Conditioning Unit	TUV SUD	SPECTRUM_SCU001	6518	12	16-Feb-2025
SCU Cable Assembly	TUV SUD	SPECTRUM_SCU_CA	6529	12	16-Feb-2025

Table 29



2.6 Maximum Conducted Output Power

2.6.1 Specification Reference

FCC 47 CFR Part 15C, Clause 15.247 (b)
ISED RSS-247, Clause 5.4
ISED RSS-GEN, Clause 6.12

2.6.2 Equipment Under Test and Modification State

A3204, S/N: CC2H2M001650000539 - Modification State 0

2.6.3 Date of Test

21-February-2024

2.6.4 Test Method

The test was performed in accordance with ANSI C63.10 clause 7.8.5 using a power meter.

2.6.5 Environmental Conditions

Ambient Temperature	21.6 °C
Relative Humidity	48.4 %



2.6.6 Test Results

2.4 GHz Bluetooth FHSS

Test Configuration			
Frequency Range:	2400-2483.5 MHz	Band:	2.4 GHz
Limit Clause(s):	15.247 (b)(1) RSS-247 5.4 b)	Test Method(s):	C63.10 7.8.5
Additional Reference(s):	-		

DUT Configuration			
Mode:	iPA GFSK (DH5)	Duty Cycle (%):	76.7
Antenna Configuration:	SISO	DCCF (dB):	-
Active Port(s):	A (Core 0)	Peak Antenna Gain (dBi):	-2.63

Test Frequency (MHz)	Maximum Conducted Output Power (dBm)					Limit (dBm)	Margin (dB)
	A	B	C	D	Σ		
2402	5.63	-	-	-	-	30.00	-24.37
2441	5.74	-	-	-	-	30.00	-24.26
2480	5.42	-	-	-	-	30.00	-24.58

Table 30 - FCC Maximum Conducted (peak) Output Power Results

Test Frequency (MHz)	Maximum Conducted Output Power (dBm)					Limit (dBm)	Margin (dB)	EIRP (dBm)	EIRP Limit (dBm)	EIRP Margin (dB)
	A	B	C	D	Σ					
2402	5.63	-	-	-	-	30.00	-24.37	2.69	36.00	-33.31
2441	5.74	-	-	-	-	30.00	-24.26	3.11	36.00	-32.89
2480	5.42	-	-	-	-	30.00	-24.58	2.41	36.00	-33.59

Table 31 - ISED Maximum Conducted (peak) Output Power Results



Test Configuration			
Frequency Range:	2400-2483.5 MHz	Band:	2.4 GHz
Limit Clause(s):	15.247 (b)(1) RSS-247 5.4 b)	Test Method(s):	C63.10 7.8.5
Additional Reference(s):	-		

DUT Configuration			
Mode:	iPA $\pi/4$ DQPSK (2-DH5)	Duty Cycle (%):	76.8
Antenna Configuration:	SISO	DCCF (dB):	-
Active Port(s):	A (Core 0)	Peak Antenna Gain (dBi):	-2.63

Test Frequency (MHz)	Maximum Conducted Output Power (dBm)					Limit (dBm)	Margin (dB)
	A	B	C	D	Σ		
2402	5.72	-	-	-	-	21.00	-15.28
2441	5.76	-	-	-	-	21.00	-15.24
2480	5.47	-	-	-	-	21.00	-15.53

Table 32 - FCC Maximum Conducted (peak) Output Power Results

Test Frequency (MHz)	Maximum Conducted Output Power (dBm)					Limit (dBm)	Margin (dB)	EIRP (dBm)	EIRP Limit (dBm)	EIRP Margin (dB)
	A	B	C	D	Σ					
2402	5.72	-	-	-	-	21.00	-15.28	2.78	36.00	-33.22
2441	5.76	-	-	-	-	21.00	-15.24	3.13	36.00	-32.87
2480	5.47	-	-	-	-	21.00	-15.53	2.46	36.00	-33.54

Table 33 - ISED Maximum Conducted (peak) Output Power Results



Test Configuration			
Frequency Range:	2400-2483.5 MHz	Band:	2.4 GHz
Limit Clause(s):	15.247 (b)(1) RSS-247 5.4 b)	Test Method(s):	C63.10 7.8.5
Additional Reference(s):	-		

DUT Configuration			
Mode:	iPA 8-DPSK (3-DH5)	Duty Cycle (%):	76.9
Antenna Configuration:	SISO	DCCF (dB):	-
Active Port(s):	A (Core 0)	Peak Antenna Gain (dBi):	-2.63

Test Frequency (MHz)	Maximum Conducted Output Power (dBm)					Limit (dBm)	Margin (dB)
	A	B	C	D	Σ		
2402	5.92	-	-	-	-	21.00	-15.08
2441	6.01	-	-	-	-	21.00	-14.99
2480	5.70	-	-	-	-	21.00	-15.30

Table 34 - FCC Maximum Conducted (peak) Output Power Results

Test Frequency (MHz)	Maximum Conducted Output Power (dBm)					Limit (dBm)	Margin (dB)	EIRP (dBm)	EIRP Limit (dBm)	EIRP Margin (dB)
	A	B	C	D	Σ					
2402	5.92	-	-	-	-	21.00	-15.08	2.98	36.00	-33.02
2441	6.01	-	-	-	-	21.00	-14.99	3.38	36.00	-32.62
2480	5.70	-	-	-	-	21.00	-15.30	2.69	36.00	-33.31

Table 35 - ISED Maximum Conducted (peak) Output Power Results

FCC 47 CFR Part 15, Limit Clause 15.247 (b)(1)

For frequency hopping systems operating in the 2400-2483.5 MHz band employing at least 75 non overlapping hopping channels, and all frequency hopping systems in the 5725-5850 MHz band: 1 watt. For all other frequency hopping systems in the 2400-2483.5 MHz band: 0.125 watts.

ISED RSS-247, Limit Clause 5.4 (b)

For FHSs operating in the band 2400-2483.5 MHz, the maximum peak conducted output power shall not exceed 1.0 W if the hopset uses 75 or more hopping channel; the maximum peak conducted output power shall not exceed 0.125 W if the hopset uses less than 75 hopping channel. The e.i.r.p. shall not exceed 4 W except as provided in section 5.4(e) of the specification.



2.6.7 Test Location and Test Equipment Used

This test was carried out in RF Laboratory 14.

Instrument	Manufacturer	Type No.	TE No.	Calibration Period (months)	Calibration Expiry Date
USB Power Sensor	Boonton	RTP5008	5820	12	07-Feb-2025
Digital Multimeter	Fluke	115	6145	12	15-Jun-2024
Humidity and Temperature Meter	R.S Components	1364	6346	12	28-Feb-2024
Signal Conditioning Unit	TUV SUD	SPECTRUM_SCU001	6426	12	07-Feb-2025

Table 36



2.7 Authorised Band Edges

2.7.1 Specification Reference

FCC 47 CFR Part 15C, Clause 15.247 (d)
ISED RSS-247, Clause 5.5

2.7.2 Equipment Under Test and Modification State

A3204, S/N: CC2H2A009C5000028E - Modification State 0

2.7.3 Date of Test

08-February-2024 to 10-February-2024

2.7.4 Test Method

The test was performed in accordance with ANSI C63.10, clause 6.10.4.

2.7.5 Environmental Conditions

Ambient Temperature	21.3 - 21.7 °C
Relative Humidity	46.2 - 48.8 %



2.7.6 Test Results

2.4 GHz Bluetooth FHSS

iPA - Core 0 (SISO)

Mode	Packet Type	TX Frequency (MHz)	Band Edge Frequency (MHz)	Level (dBc)
Static	DH5	2402	2400	-50.99
Static	2-DH5	2402	2400	-48.10
Static	3-DH5	2402	2400	-47.91
Hopping	DH5	Hopping	2400	-52.74
Hopping	2-DH5	Hopping	2400	-52.07
Hopping	3-DH5	Hopping	2400	-52.36

Table 37 - SISO Authorised Band Edge Results

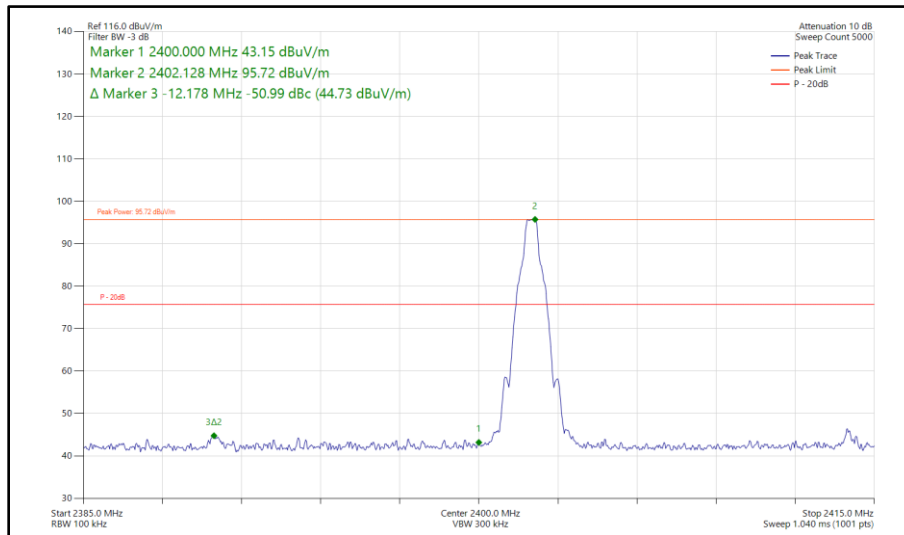

**Figure 34 - Bluetooth DH5, SISO, Core 0 - 2402 MHz
 Band Edge Frequency 2400 MHz**

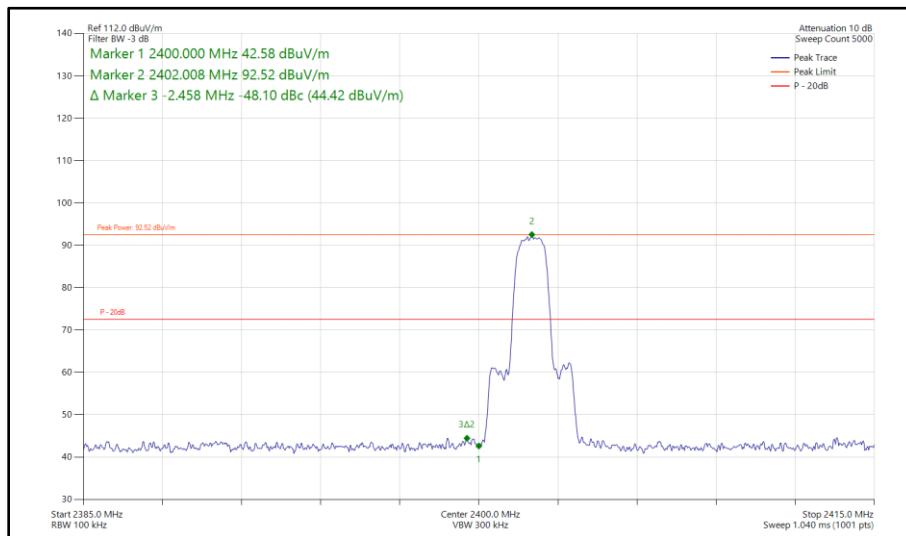

**Figure 35 - Bluetooth 2-DH5, SISO, Core 0 - 2402 MHz
Band Edge Frequency 2400 MHz**

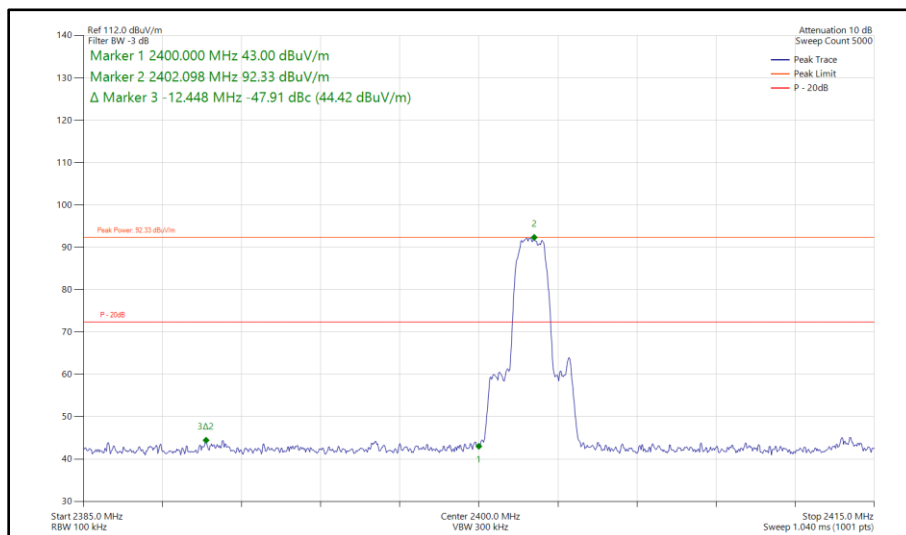

**Figure 36 - Bluetooth 3-DH5, SISO, Core 0 - 2402 MHz
Band Edge Frequency 2400 MHz**

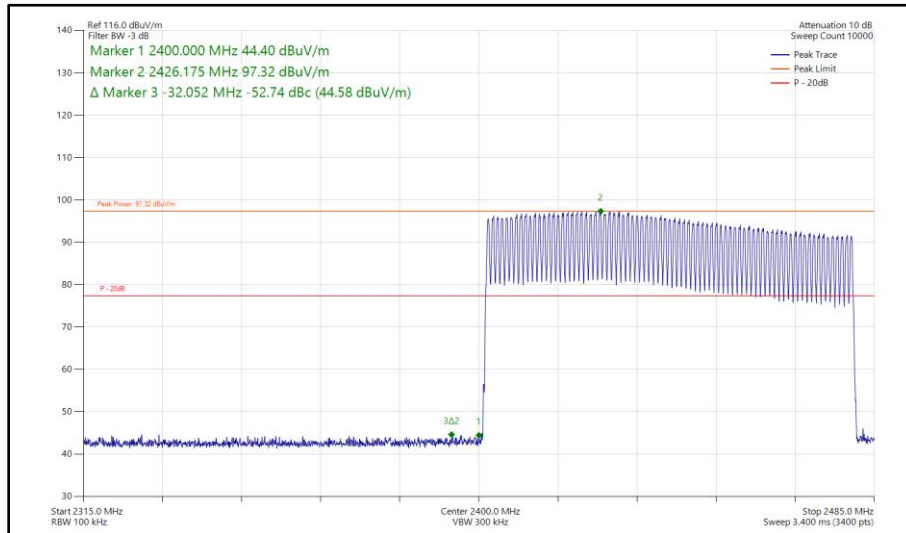

**Figure 37 - Bluetooth DH5, SISO, Core 0 - Hopping
Band Edge Frequency 2400 MHz**

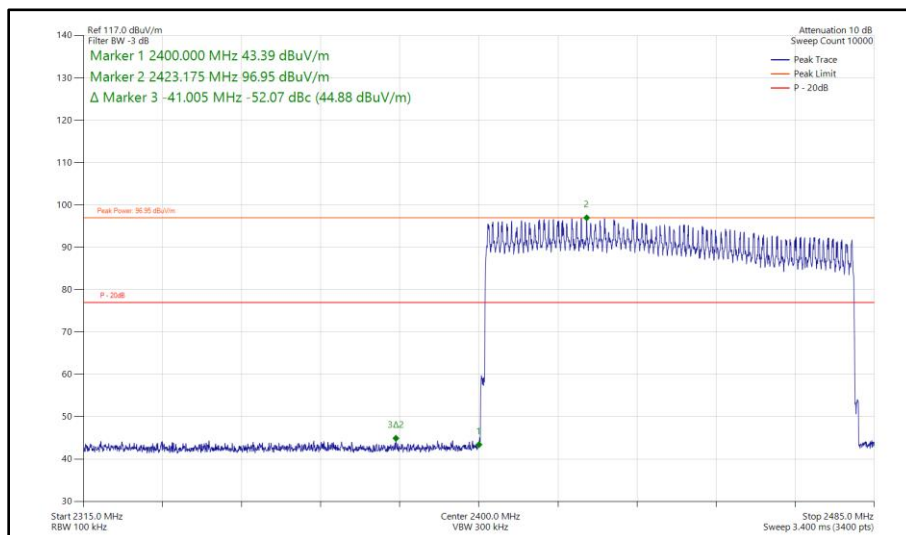

**Figure 38 - Bluetooth 2-DH5, SISO, Core 0 - Hopping
Band Edge Frequency 2400 MHz**



2.7.7 Test Location and Test Equipment Used

This test was carried out in RF Chamber 16.

Instrument	Manufacturer	Type No.	TE No.	Calibration Period (months)	Calibration Expiry Date
Emissions Software	TUV SUD	EmX V3.2.0	5125	-	Software
1500W (300V 12A) AC Power Supply	iTech	IT7324	5957	-	O/P Mon
3m Semi-Anechoic Chamber, Chamber16	Albatross Projects	RF Chamber 16	5972	36	24-May-2025
Mast & Turntable Controller	Maturo Gmbh	FCU3.0	5973	-	TU
Tilt Antenna Mast	Maturo Gmbh	BAM4.5-P	5974	-	TU
Turntable	Maturo Gmbh	TT1.5SI	5975	-	TU
Cable (SMA to SMA 1m)	Junkosha	MWX221-01000AMSAMS/A	6018	12	05-Jun-2024
Horn Antenna (1-10 GHz)	Schwarzbeck	BBHA9120B	6140	12	26-Aug-2024
Horn Antenna (1-10 GHz)	Schwarzbeck	BBHA9120B	6142	12	26-Aug-2024
Digital Multimeter	Fluke	115	6146	12	15-Jun-2024
Humidity & Temperature meter	R.S Components	1364	6148	12	21-Jul-2024
SAC Switch Unit	TUV SUD	TUV_SSU_001	6190	12	22-Dec-2024
EMI Test Receiver	Rohde & Schwarz	ESW44	6294	12	29-Nov-2024
Cable (SMA to SMA 8m)	Junkosha	MWX221-08000AMSAMS/B	6318	12	12-Feb-2024

Table 38

TU - Traceability Unscheduled
 O/P Mon - Output Monitored using calibrated equipment



2.8 Spurious Radiated Emissions

2.8.1 Specification Reference

FCC 47 CFR Part 15C, Clause 15.209 and 15.247 (d)
ISED RSS-247, Clause 3.3 and 5.5
ISED RSS-GEN, Clause 6.13 and 8.9

2.8.2 Equipment Under Test and Modification State

A3204, S/N: CC2H2A009C5000028E - Modification State 0

2.8.3 Date of Test

04-February-2024

2.8.4 Test Method

This test was performed in accordance with ANSI C63.10, clause 6.3, 6.5 and 6.6.

For frequencies > 1 GHz, plots for average measurements were taken in accordance with ANSI C63.10 (2020) clause 4.1.5.2.6 to characterize the EUT.

Where emissions were detected, final average measurements were taken in accordance with ANSI C63.10 (2020) clause 4.1.5.2.2.

The EUT was placed on the non-conducting platform in a manner typical of a normal installation.

Ports on the EUT were terminated with loads as described in ANSI C63.10 clause 5.10.

In the 30 MHz to 1 GHz range pre-scans were only performed on the mid channel (2441 MHz) only.

The plots shown are the characterisation of the EUT. The limits on the plots represent the most stringent case for restricted bands, (74/54 dBuV/m) when compared to 20 dBc outside restricted bands. The limits shown have been used as a threshold to determine where further measurements are necessary. Where results are within 10 dB of the limits shown on the plots, further investigation was carried out and reported in results tables.

The following conversion can be applied to convert from dBuV/m to uV/m:
 $10^{(\text{Field Strength in dBuV/m}/20)}$.

To determine the emission characteristic of the EUT above 18 GHz, the test antenna was swept over all faces of the EUT whilst observing a spectral display. The frequency of any emissions of interest was noted for formal measurement at the correct measurement distance of 1m. This procedure was repeated for all relevant transmit operating channels.

At a measurement distance of 1 meter the limit line was increased by $20 \cdot \text{LOG}(3/1) = 9.54$ dB.

Where formal measurements have been necessary, the results have been presented in the emissions table.

2.8.5 Example Test Setup Diagram

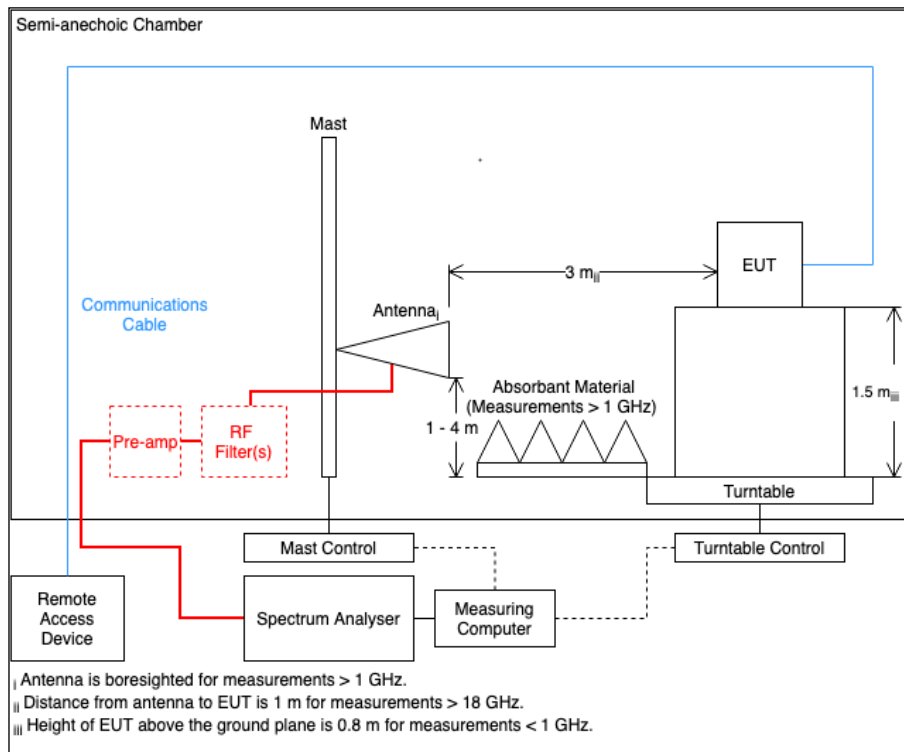

Figure 40

2.8.6 Environmental Conditions

Ambient Temperature 22.2 °C
 Relative Humidity 43.3 %



2.8.7 Test Results

2.4 GHz Bluetooth FHSS

Frequency (MHz)	Level (dBµV/m)	Limit (dBµV/m)	Margin (dB)	Detector	Angle (°)	Height (cm)	Polarisation
2353.760	29.39	54.00	-24.61	CISPR Avg	300	192	Vertical
2353.868	31.35	54.00	-22.65	CISPR Avg	9	340	Horizontal
4803.633	35.45	54.00	-18.55	CISPR Avg	262	247	Horizontal
4804.124	40.19	54.00	-13.81	CISPR Avg	343	112	Vertical

Table 39 - 2402 MHz (CH0), DH5, iPA, Core 0, 1 GHz to 26 GHz

No other emissions found within 10 dB of the limit.

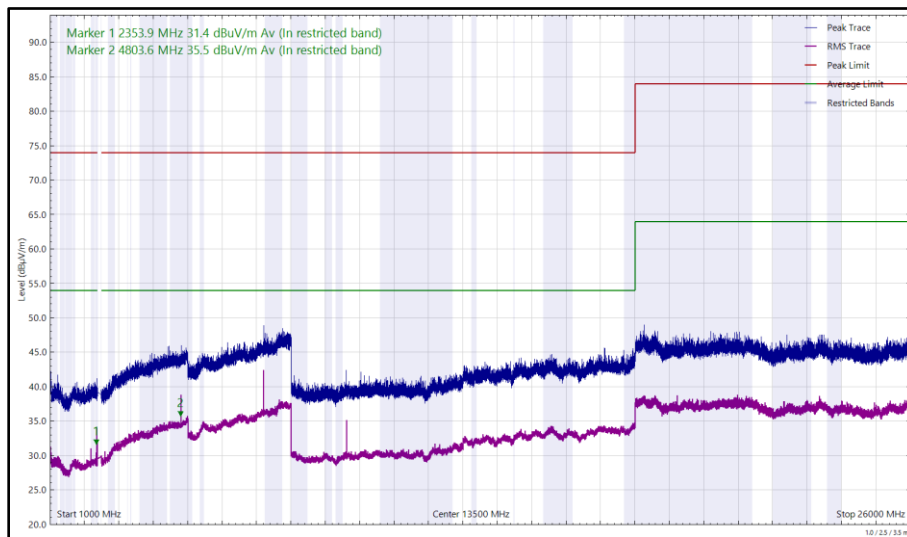

Figure 41 - 2402 MHz (CH0), DH5, iPA, Core 0, 1 GHz to 26 GHz, Horizontal

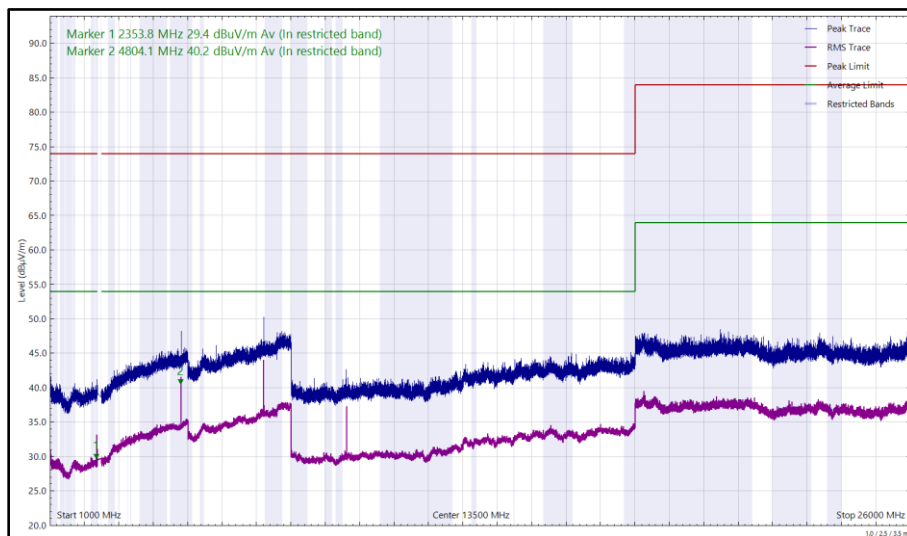

Figure 42 - 2402 MHz (CH0), DH5, iPA, Core 0, 1 GHz to 26 GHz, Vertical



Frequency (MHz)	Level (dB μ V/m)	Limit (dB μ V/m)	Margin (dB)	Detector	Angle (°)	Height (cm)	Polarisation
2392.937	36.28	54.00	-17.72	CISPR Avg	202	124	Horizontal
4881.678	37.71	54.00	-16.29	CISPR Avg	79	300	Vertical
4881.763	33.13	54.00	-20.87	CISPR Avg	0	263	Horizontal
7323.110	39.19	54.00	-14.81	CISPR Avg	268	313	Horizontal
7323.505	37.95	54.00	-16.05	CISPR Avg	79	289	Vertical

Table 40 - 2441 MHz (CH39), DH5, iPA, Core 0, 30 MHz to 26 GHz

No other emissions found within 10 dB of the limit.

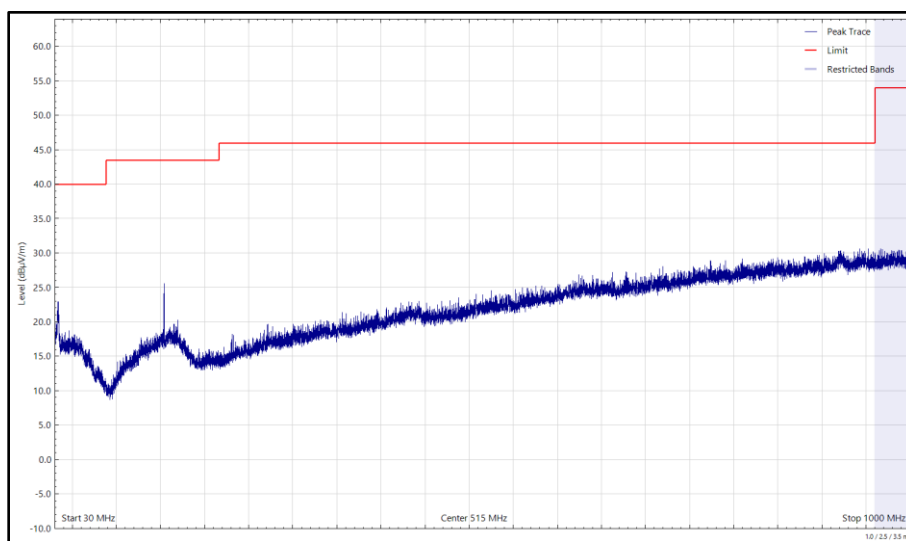

Figure 43 - 2441 MHz (CH39), DH5, iPA, Core 0, 30 MHz to 1 GHz, Horizontal (Peak)

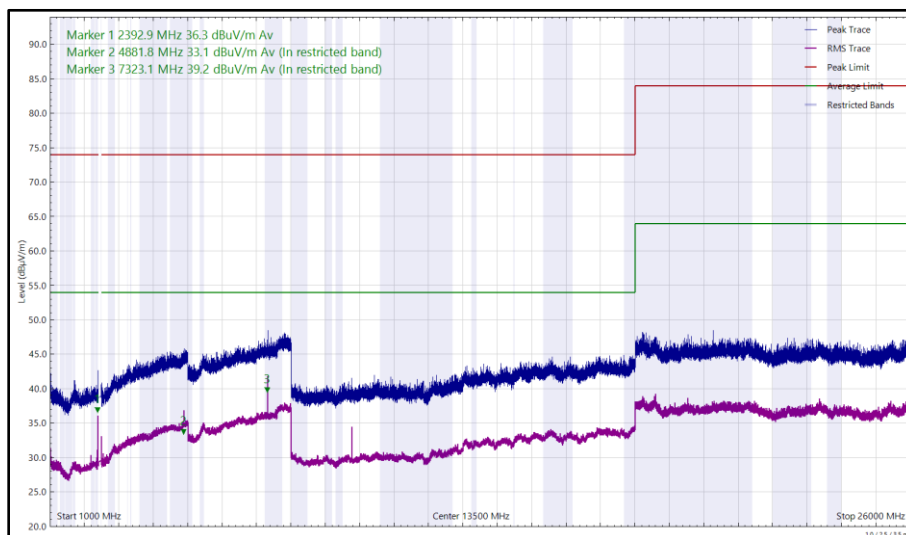

Figure 44 - 2441 MHz (CH39), DH5, iPA, Core 0, 1 GHz to 26 GHz, Horizontal

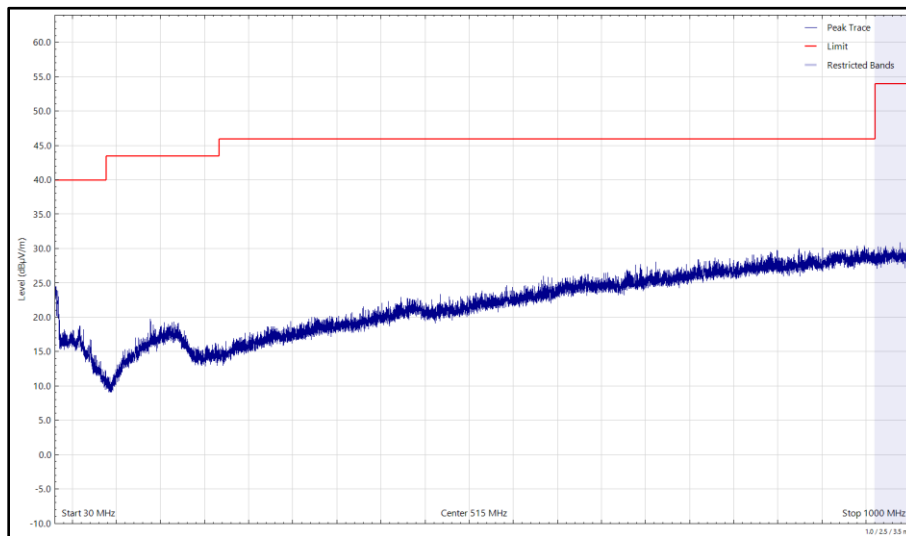

Figure 45 - 2441 MHz (CH39), DH5, iPA, Core 0, 30 MHz to 1 GHz, Vertical (Peak)

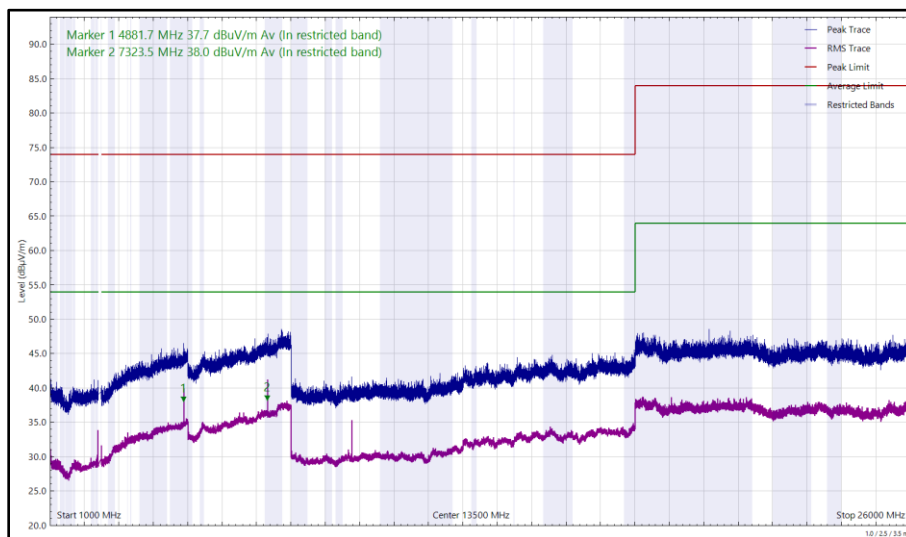

Figure 46 - 2441 MHz (CH39), DH5, iPA, Core 0, 1 GHz to 26 GHz, Vertical



Frequency (MHz)	Level (dB μ V/m)	Limit (dB μ V/m)	Margin (dB)	Detector	Angle (°)	Height (cm)	Polarisation
4959.838	38.27	54.00	-15.73	CISPR Avg	79	353	Vertical
7439.709	36.54	54.00	-17.46	CISPR Avg	0	335	Horizontal
7439.880	39.34	54.00	-14.66	CISPR Avg	157	223	Vertical

Table 41 - 2480 MHz (CH78), DH5, iPA, Core 0, 1 GHz to 26 GHz

No other emissions found within 10 dB of the limit.

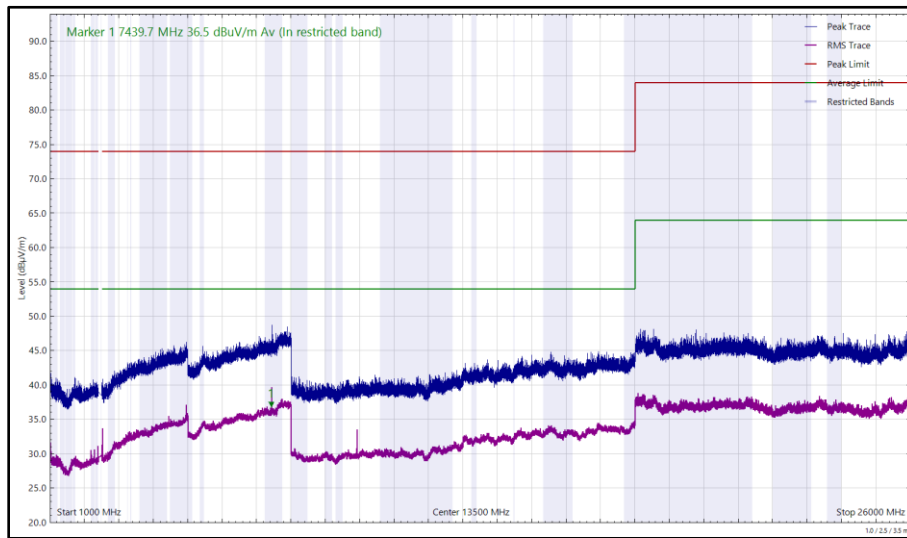

Figure 47 - 2480 MHz (CH78), DH5, iPA, Core 0, 1 GHz to 26 GHz, Horizontal

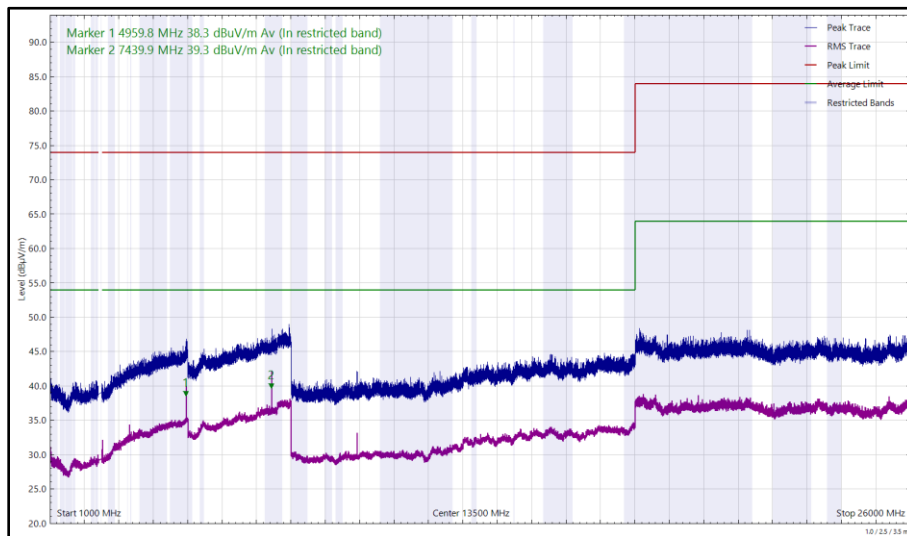

Figure 48 - 2480 MHz (CH78), DH5, iPA, Core 0, 1 GHz to 26 GHz, Vertical



FCC 47 CFR Part 15, Limit Clause 15.247 (d)

In any 100 kHz bandwidth outside the frequency band in which the spread spectrum or digitally modulated intentional radiator is operating, the radio frequency power that is produced by the intentional radiator shall be at least 20 dB below that in the 100 kHz bandwidth within the band that contains the highest level of the desired power, based on either an RF conducted or a radiated measurement, provided the transmitter demonstrates compliance with the peak conducted power limits. If the transmitter complies with the conducted power limits based on the use of RMS averaging over a time interval, as permitted under paragraph (b)(3) of this section, the attenuation required under this paragraph shall be 30 dB instead of 20 dB.

Attenuation below the general limits specified in § 15.209(a) is not required. In addition, radiated emissions which fall in the restricted bands, as defined in § 15.205(a), must also comply with the radiated emission limits specified in 15.209(a)

ISED RSS-247, Limit Clause 5.5

In any 100 kHz bandwidth outside the frequency band in which the spread spectrum or digitally modulated device is operating, the RF power that is produced shall be at least 20 dB below that in the 100 kHz bandwidth within the band that contains the highest level of the desired power, based on either an RF conducted or a radiated measurement, provided that the transmitter demonstrates compliance with the peak conducted power limits. If the transmitter complies with the conducted power limits based on the use of root-mean-square averaging over a time interval, as permitted under Section 5.4(4), the attenuation required shall be 30 dB instead of 20 dB. Attenuation below the general field strength limits specified in RSS-Gen is not required.

In addition, radiated emissions which fall in the restricted bands, as defined in RSS-GEN, clause 8.10, must also comply with the radiated emission limits specified in RSS-GEN clause 8.9.



2.8.8 Test Location and Test Equipment Used

This test was carried out in RF Chamber 16.

Instrument	Manufacturer	Type No.	TE No.	Calibration Period (months)	Calibration Expiry Date
Emissions Software	TUV SUD	EmX V3.2.0	5125	-	Software
Attenuator 5W 30dB DC-18GHz	Aaren	AT40A-4041-D18-30	5505	12	21-Feb-2024
DRG Horn Antenna (7.5-18GHz)	Schwarzbeck	HWRD750	5940	12	09-Jul-2024
1500W (300V 12A) AC Power Supply	iTech	IT7324	5957	-	O/P Mon
3m Semi-Anechoic Chamber, Chamber16	Albatross Projects	RF Chamber 16	5972	36	24-May-2025
Mast & Turntable Controller	Maturo Gmbh	FCU3.0	5973	-	TU
Tilt Antenna Mast	Maturo Gmbh	BAM4.5-P	5974	-	TU
Turntable	Maturo Gmbh	TT1.5SI	5975	-	TU
Cable (SMA to SMA 1m)	Junkosha	MWX221-01000AMSAMS/A	5996	12	05-Jun-2024
Cable (SMA to SMA 1m)	Junkosha	MWX221-01000AMSAMS/A	6018	12	05-Jun-2024
Horn Antenna (1-10 GHz)	Schwarzbeck	BBHA9120B	6142	12	26-Aug-2024
Digital Multimeter	Fluke	115	6146	12	15-Jun-2024
Humidity & Temperature meter	R.S Components	1364	6148	12	21-Jul-2024
Double Ridge Active Horn Antenna (18-40 GHz)	Com-Power	AHA-840	6188	24	02-Jun-2024
SAC Switch Unit	TUV SUD	TUV_SSU_001	6190	12	22-Dec-2024
Pre Amp 8 - 18 GHz	Wright Technologies	APS06 0061	6198	12	14-Jul-2024
Attenuator (4 dB)	Pasternack	PE7074-4	6202	24	16-Jul-2024
EMI Test Receiver	Rohde & Schwarz	ESW44	6294	12	29-Nov-2024
Cable (SMA to SMA 8m)	Junkosha	MWX221-08000AMSAMS/B	6318	12	04-Feb-2024
8 GHz High Pass Filter	Wainwright	WHKX 7150 8000 18000 50SS	6427	12	24-Jul-2024
Trilog Super Broadband Test Antenna	Schwarzbeck	VULB 9168	6456	24	21-Jan-2025

Table 42

TU - Traceability Unscheduled
 O/P Mon - Output Monitored using calibrated equipment



3 Measurement Uncertainty

For a 95% confidence level, the measurement uncertainties for defined systems are:

Test Name	Measurement Uncertainty
Restricted Band Edges	30 MHz to 1 GHz: ± 5.2 dB 1 GHz to 40 GHz: ± 6.3 dB
Frequency Hopping Systems - Average Time of Occupancy	-
Frequency Hopping Systems - Channel Separation	± 42.30 kHz
Frequency Hopping Systems - Number of Hopping Channels	-
Frequency Hopping Systems - 99% & 20 dB Bandwidth	99%: ± 37.42 kHz 20 dB: ± 42.30 kHz
Maximum Conducted Output Power	± 1.38 dB
Authorised Band Edges	30 MHz to 1 GHz: ± 5.2 dB 1 GHz to 40 GHz: ± 6.3 dB
Spurious Radiated Emissions	30 MHz to 1 GHz: ± 5.2 dB 1 GHz to 40 GHz: ± 6.3 dB

Table 43

Measurement Uncertainty Decision Rule – Accuracy Method

Determination of conformity with the specification limits is based on the decision rule according to IEC Guide 115:2021, Clause 4.4.3 (Procedure 2). The measurement results are directly compared with the test limit to determine conformance with the requirements of the standard.

Risk: The uncertainty of measurement about the measured result is negligible with regard to the final pass/fail decision. The measurement result can be directly compared with the test limit to determine conformance with the requirement (compare IEC Guide 115). The level of risk to falsely accept and falsely reject items is further described in ILAC-G8.