

Figure 218 - Bluetooth 2-DH5, MIMO, Core 0 - Core 1 - Hopping Band Edge Frequency 2400 MHz

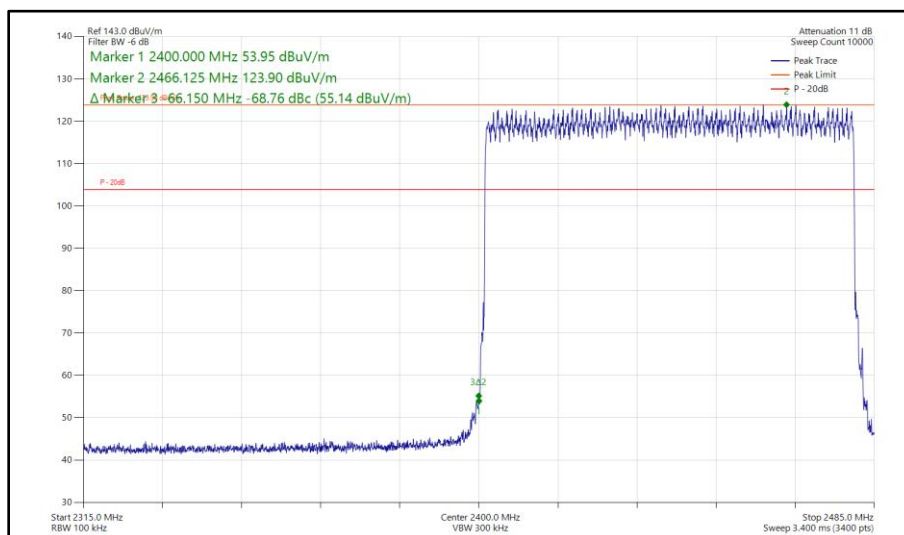

Figure 219 - Bluetooth 3-DH5, MIMO, Core 0 - Core 1 - Hopping Band Edge Frequency 2400 MHz

FCC 47 CFR Part 15, Limit Clause 15.247 (d)

20 dB below the fundamental measured in a 100 kHz bandwidth using a peak detector. If the transmitter complies with the conducted power limits, based on the use of RMS averaging over a time interval, the attenuation required shall be 30 dB below the fundamental instead of 20 dB.



2.7.7 Test Location and Test Equipment Used

This test was carried out in RF Chamber 14 and RF Chamber 15.

Instrument	Manufacturer	Type No.	TE No.	Calibration Period (months)	Calibration Expiry Date
Emissions Software	TUV SUD	EmX V3.4.2	5125	-	Software
EMI Test Receiver	Rohde & Schwarz	ESW44	5911	12	11-Sep-2024
Test Receiver	Rohde & Schwarz	ESW44	5914	12	24-May-2025
1500W (300V 12A) AC Power Supply	iTech	IT7324	5955	-	O/P Mon
1500W (300V 12A) AC Power Supply	iTech	IT7324	5956	-	O/P Mon
5m Semi-Anechoic Chamber (Dual-Axis)	Albatross Projects	RF Chamber 14	5958	36	26-Apr-2025
Compact Antenna Mast	Maturo Gmbh	CAM4.0-P	5959	-	TU
Mast & Turntable Controller	Maturo Gmbh	FCU3.0	5960	-	TU
Tilt Antenna Mast	Maturo Gmbh	BAM4.5-P	5961	-	TU
Turntable	Maturo Gmbh	TT1.5SI	5962	-	TU
5m Semi-Anechoic Chamber (Dual-Axis), Chamber 15	Albatross Projects	RF Chamber 15	5963	36	28-Apr-2025
Compact Antenna Mast	Maturo Gmbh	CAM4.0-P	5964	-	TU
Mast & Turntable Controller	Maturo Gmbh	FCU3.0	5966	-	TU
Tilt Antenna Mast	Maturo Gmbh	BAM4.5-P	5967	-	TU
Turntable	Maturo Gmbh	TT1.5SI	5968	-	TU
Cable (SMA to SMA 1m)	Junkosha	MWX221-01000AMSAMS/A	5997	12	14-Sep-2024
Cable (N to N 1m)	Junkosha	MWX221-01000NMSNMS/B	5999	12	20-May-2025
Cable (SMA to SMA 4.5m)	Junkosha	MWX221-04500AMSAMS/A	6002	12	14-Sep-2024
Cable (SMA to SMA 1m)	Junkosha	MWX221-01000AMSAMS/A	6007	12	20-May-2025
Cable (SMA to SMA 6.5m)	Junkosha	MWX221-06500AMSAMS/B	6014	12	24-Aug-2024
Cable (SMA to SMA 1m)	Junkosha	MWX221-01000AMSAMS/A	6018	12	10-Jun-2025
Cable (SMA to SMA 3m)	Junkosha	MWX221-03000AMSAMS/A	6021	12	14-Sep-2024
Horn Antenna (1-10 GHz)	Schwarzbeck	BBHA9120B	6141	12	05-May-2025
Horn Antenna (1-10 GHz)	Schwarzbeck	BBHA9120B	6142	12	05-May-2025
Digital Multimeter	Fluke	115	6145	12	06-Jun-2025
Digital Multimeter	Fluke	115	6146	12	06-Jun-2025
Humidity & Temperature meter	R.S Components	1364	6148	12	29-Jul-2025
SAC Switch Unit	TUV SUD	TUV_SSU_001	6190	12	22-Dec-2024
SAC Switch Unit	TUV SUD	TUV_SSU_001	6191	12	18-Dec-2024



Instrument	Manufacturer	Type No.	TE No.	Calibration Period (months)	Calibration Expiry Date
Cable (SMA to SMA 3m)	Junkosha	MWX221-03000AMSAMS/A	6316	12	04-Feb-2025
Cable (SMA to SMA 8m)	Junkosha	MWX221-08000AMSAMS/B	6319	12	04-Feb-2025
Humidity and Temperature Meter	R.S Components	1364	6486	12	04-Jun-2025
1m Cable	Junkosha	MWX241-01000AMSAMS/B	6740	12	01-Feb-2025
1m Cable	Junkosha	MWX241-01000AMSAMS/B	6741	12	01-Feb-2025
6.5m Cable	Junkosha	MWX221-06500AMSAMS/B	6744	12	01-Feb-2025

Table 119

TU - Traceability Unscheduled
O/P Mon - Output Monitored using calibrated equipment



2.8 Spurious Radiated Emissions

2.8.1 Specification Reference

FCC 47 CFR Part 15C, Clause 15.209 and 15.247 (d)

2.8.2 Equipment Under Test and Modification State

A3186, S/N: GQFXQXKN7J - Modification State 0

2.8.3 Date of Test

01-August-2024 to 05-August-2024

2.8.4 Test Method

This test was performed in accordance with ANSI C63.10, clause 6.3, 6.5 and 6.6.

The EUT was placed on the non-conducting platform in a manner typical of a normal installation. In the 30 MHz to 1 GHz range pre-scans were only performed on the mid channel (2441 MHz) only.

The plots shown are the characterisation of the EUT. The limits on the plots represent the most stringent case for restricted bands, (74/54 dBuV/m) when compared to 20 dBc outside restricted bands. The limits shown have been used as a threshold to determine where further measurements are necessary. Where results are within 20 dB of the limits shown on the plots, further investigation was carried out and reported in results tables.

Ports on the EUT were terminated with loads as described in ANSI C63.4 clause 6.2.4. For EUT's with multiple connectors of the same type, additional interconnecting cables were connected, and pre-scans performed to determine whether the level of the emissions were increased by >2 dB.

The following conversion can be applied to convert from dB μ V/m to μ V/m:
 $10^{(\text{Field Strength in dB}\mu\text{V/m}/20)}$.

Above 18 GHz, the measurement distance was reduced to 1 m. The limit line was increased by $20 \cdot \text{LOG}(3/1) = 9.54$ dB.

Where formal measurements have been necessary, the results have been presented in the emissions table.

Radiated spurious emissions tests have been conducted in 2-DH5 ePA (high power) and DH5 iPA (low power) modes as these represent worst case with respect to Power and PSD.

2.8.5 Example Test Setup Diagram

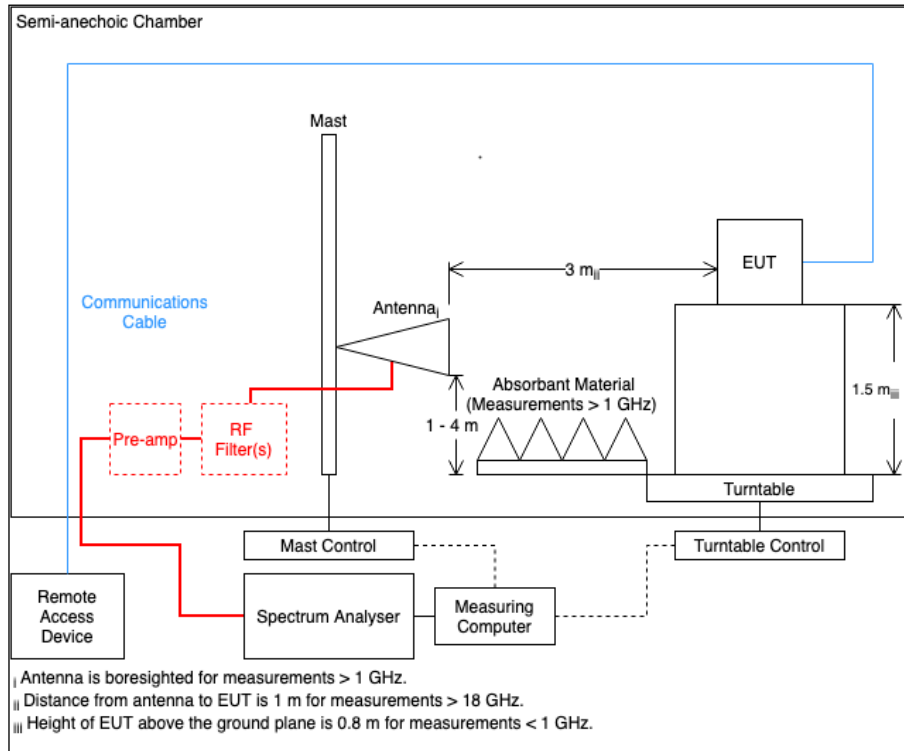

Figure 220

2.8.6 Environmental Conditions

Ambient Temperature	22.4 - 24.5 °C
Relative Humidity	43.6 - 49.2 %



2.8.7 Test Results

2.4 GHz Bluetooth BDR/EDR

Frequency (MHz)	Level (dBμV/m)	Limit (dBμV/m)	Margin (dB)	Detector	Angle (°)	Height (cm)	Polarisation
2374.734	32.53	54.00	-21.47	CISPR Avg	55	384	Horizontal
2374.991	37.39	54.00	-16.61	CISPR Avg	2	352	Vertical

Table 120 - 2402 MHz (CH0), 2-DH5, ePA, Core 0 + Core 1, 1 GHz to 26 GHz

No other emissions found within 10 dB of the limit.

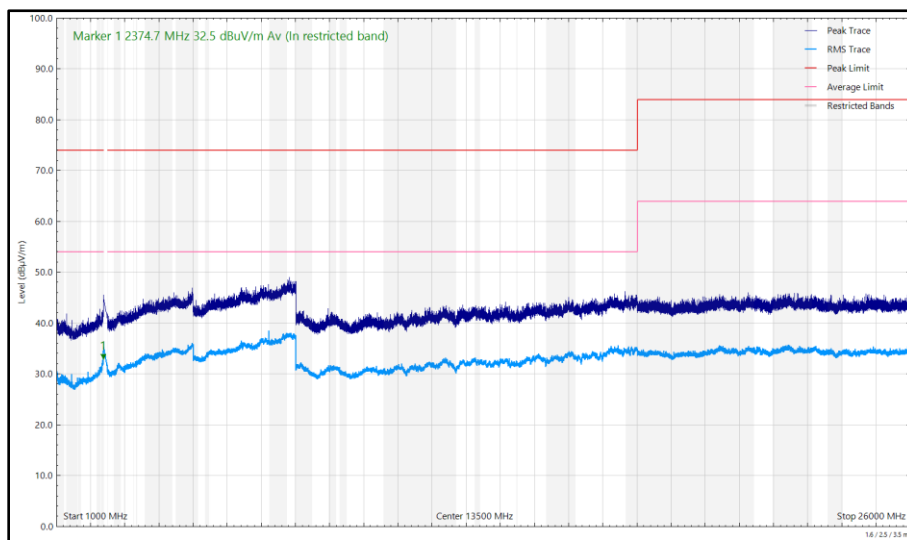

Figure 221 - 2402 MHz (CH0), 2-DH5, ePA, Core 0 + Core 1, 1 GHz to 26 GHz, Horizontal

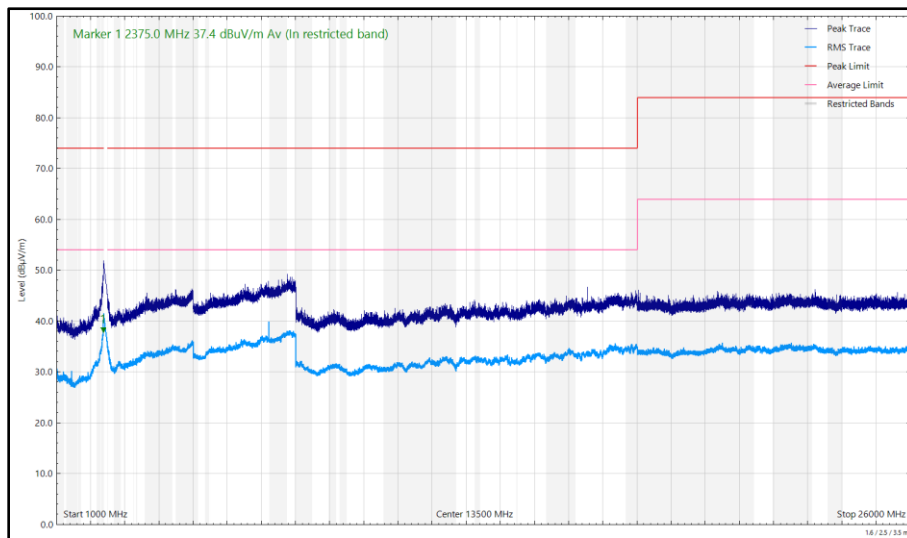

Figure 222 - 2402 MHz (CH0), 2-DH5, ePA, Core 0 + Core 1, 1 GHz to 26 GHz, Vertical



Frequency (MHz)	Level (dBµV/m)	Limit (dBµV/m)	Margin (dB)	Detector	Angle (°)	Height (cm)	Polarisation
74.274	21.85	40.00	-18.15	Q-Peak	73	110	Vertical
166.993	18.25	43.50	-25.25	Q-Peak	350	140	Horizontal
409.416	23.11	46.00	-22.89	Q-Peak	175	120	Vertical
2387.145	35.04	54.00	-18.96	CISPR Avg	15	317	Vertical
2483.985	35.10	54.00	-18.90	CISPR Avg	9	335	Vertical
7323.165	34.82	54.00	-19.18	CISPR Avg	85	365	Horizontal
7323.375	35.95	54.00	-18.05	CISPR Avg	350	284	Vertical

Table 121 - 2441 MHz (CH39), 2-DH5, ePA, Core 0 + Core 1, 30 MHz to 26 GHz

No other emissions found within 10 dB of the limit.

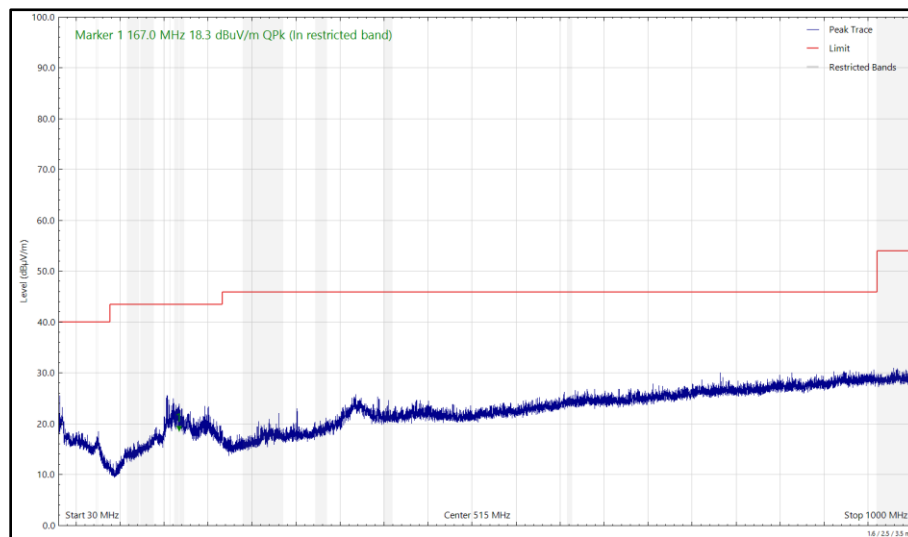

Figure 223 - 2441 MHz (CH39), 2-DH5, ePA, Core 0 + Core 1, 30 MHz to 1 GHz, Horizontal (Peak)

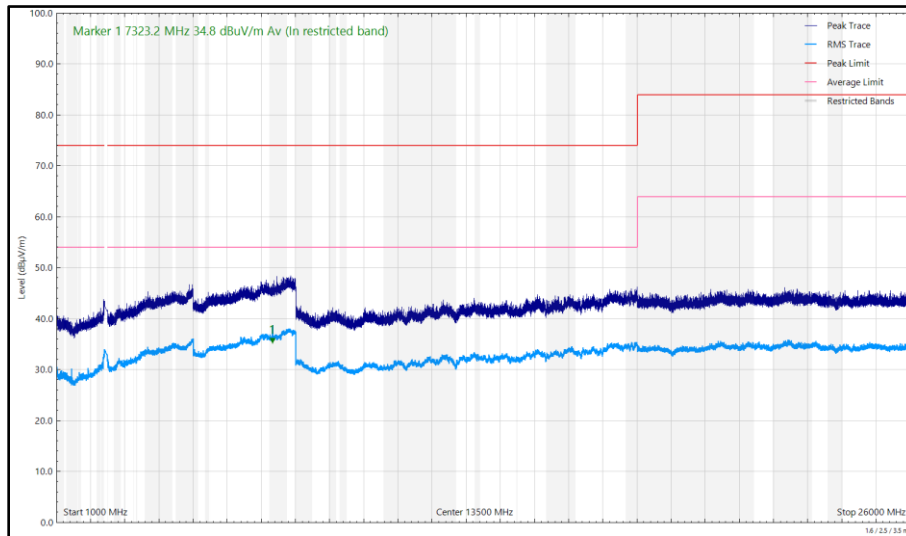

Figure 224 - 2441 MHz (CH39), 2-DH5, ePA, Core 0 + Core 1, 1 GHz to 26 GHz, Horizontal

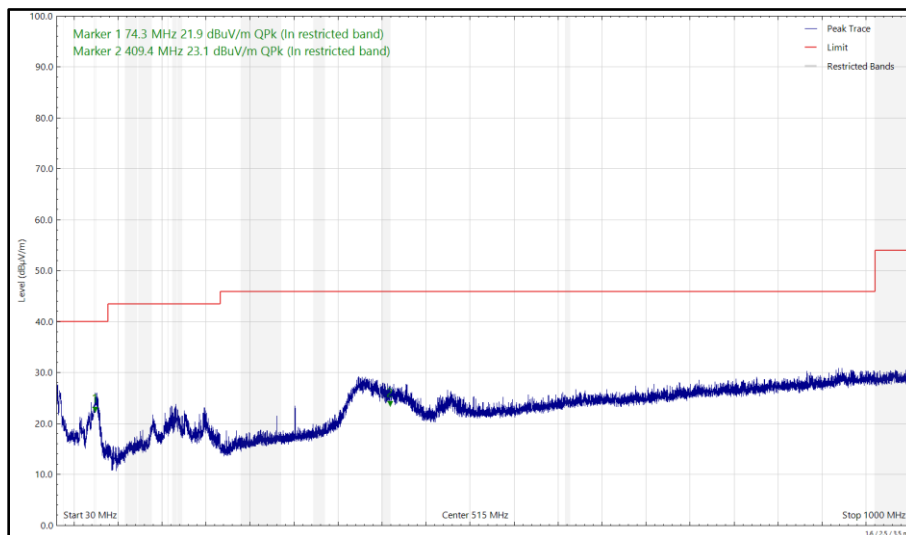

Figure 225 - 2441 MHz (CH39), 2-DH5, ePA, Core 0 + Core 1, 30 MHz to 1 GHz, Vertical (Peak)

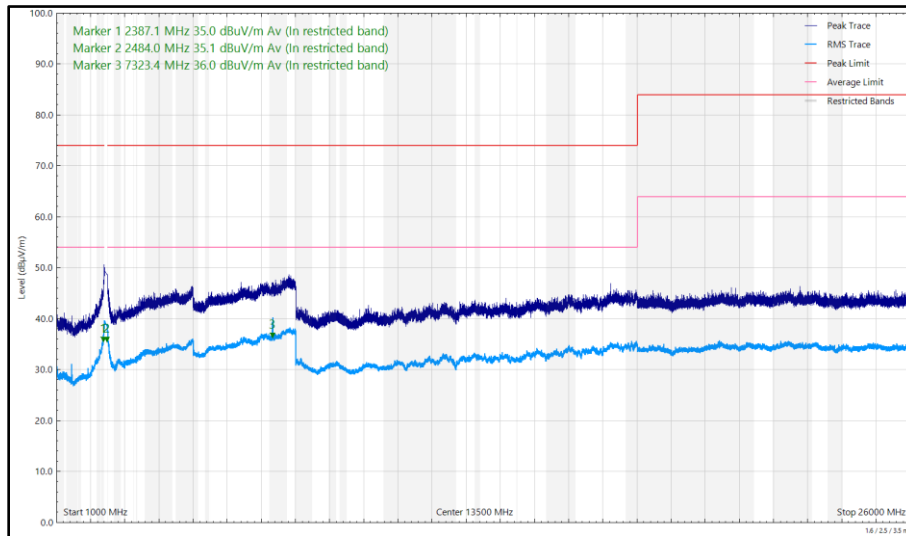

Figure 226 - 2441 MHz (CH39), 2-DH5, ePA, Core 0 + Core 1, 1 GHz to 26 GHz, Vertical



Frequency (MHz)	Level (dB μ V/m)	Limit (dB μ V/m)	Margin (dB)	Detector	Angle (°)	Height (cm)	Polarisation
2388.106	33.55	54.00	-20.45	CISPR Avg	30	308	Vertical
2498.591	38.91	54.00	-15.09	CISPR Avg	29	376	Vertical
2499.736	32.53	54.00	-21.47	CISPR Avg	57	388	Horizontal
7439.550	35.47	54.00	-18.53	CISPR Avg	353	282	Vertical

Table 122 - 2480 MHz (CH78), 2-DH5, ePA, Core 0 + Core 1, 1 GHz to 26 GHz

No other emissions found within 10 dB of the limit.

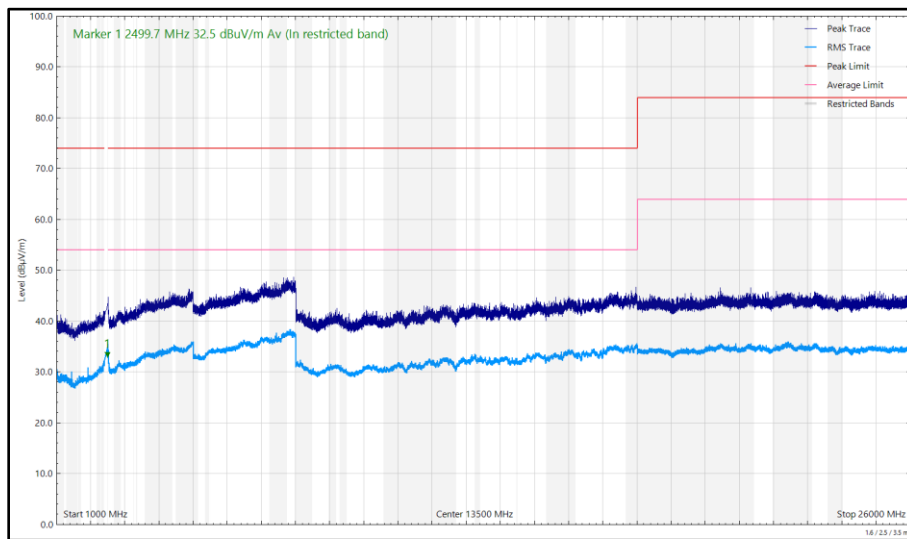

Figure 227 - 2480 MHz (CH78), 2-DH5, ePA, Core 0 + Core 1, 1 GHz to 26 GHz, Horizontal

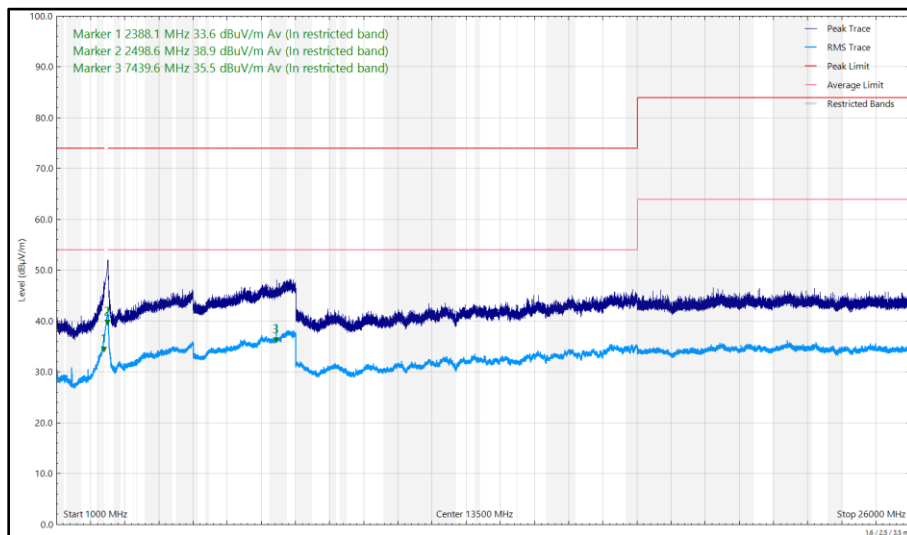

Figure 228 - 2480 MHz (CH78), 2-DH5, ePA, Core 0 + Core 1, 1 GHz to 26 GHz, Vertical



Frequency (MHz)	Level (dBµV/m)	Limit (dBµV/m)	Margin (dB)	Detector	Angle (°)	Height (cm)	Polarisation
2373.734	31.85	54.00	-22.15	CISPR Avg	1	313	Vertical

Table 123 - 2402 MHz (CH0), DH5, iPA, Core 0 + Core 1, 1 GHz to 26 GHz

No other emissions found within 10 dB of the limit.

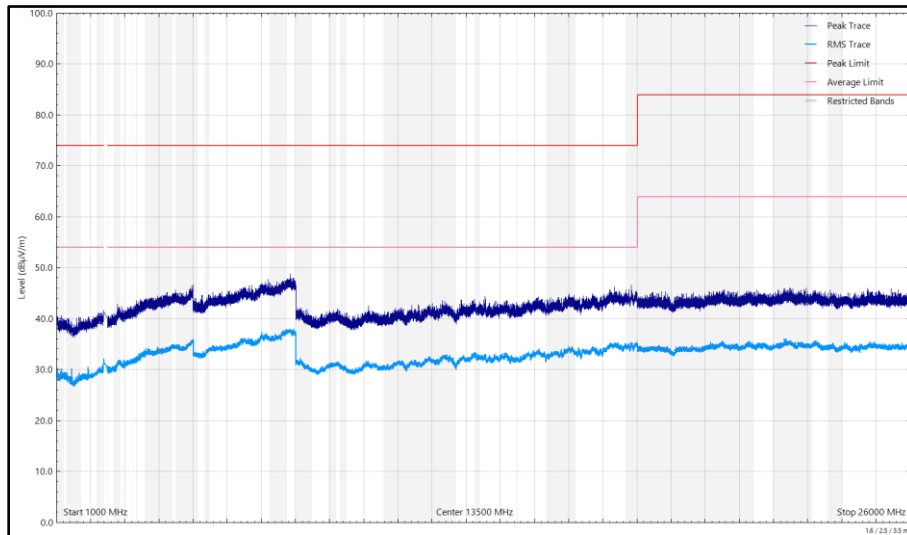

Figure 229 - 2402 MHz (CH0), DH5, iPA, Core 0 + Core 1, 1 GHz to 26 GHz, Horizontal

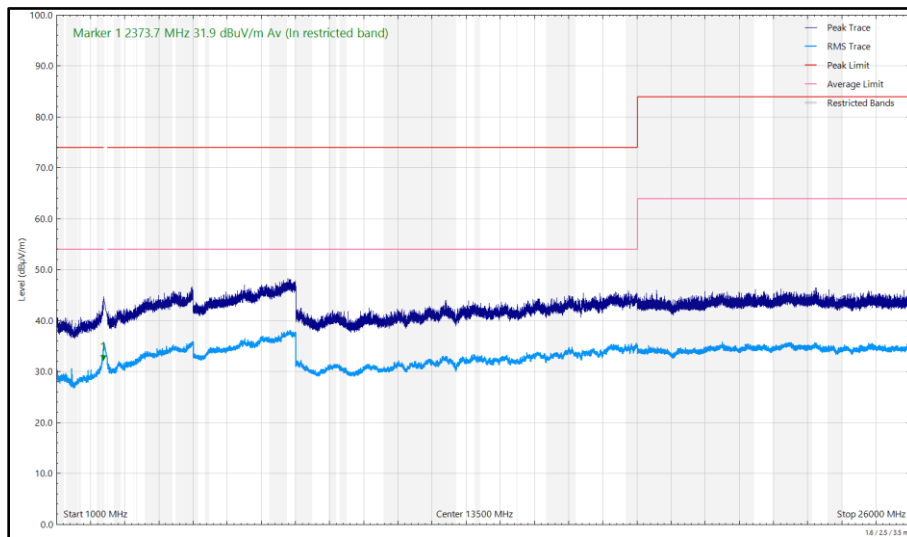

Figure 230 - 2402 MHz (CH0), DH5, iPA, Core 0 + Core 1, 1 GHz to 26 GHz, Vertical



Frequency (MHz)	Level (dBµV/m)	Limit (dBµV/m)	Margin (dB)	Detector	Angle (°)	Height (cm)	Polarisation
75.039	22.35	40.00	-17.65	Q-Peak	74	100	Vertical
166.154	16.72	43.50	-26.78	Q-Peak	225	100	Vertical
166.516	13.28	43.50	-30.22	Q-Peak	202	271	Horizontal
402.717	22.99	46.00	-23.01	Q-Peak	171	125	Vertical
2385.678	29.93	54.00	-24.07	CISPR Avg	359	349	Vertical

Table 124 - 2441 MHz (CH39), DH5, iPA, Core 0 + Core 1, 30 MHz to 26 GHz

No other emissions found within 10 dB of the limit.

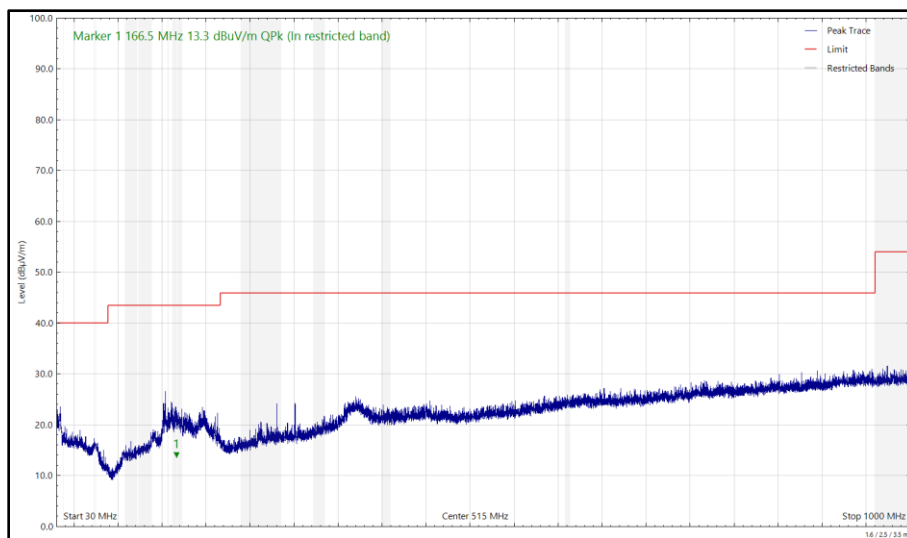

Figure 231 - 2441 MHz (CH39), DH5, iPA, Core 0 + Core 1, 30 MHz to 1 GHz, Horizontal (Peak)

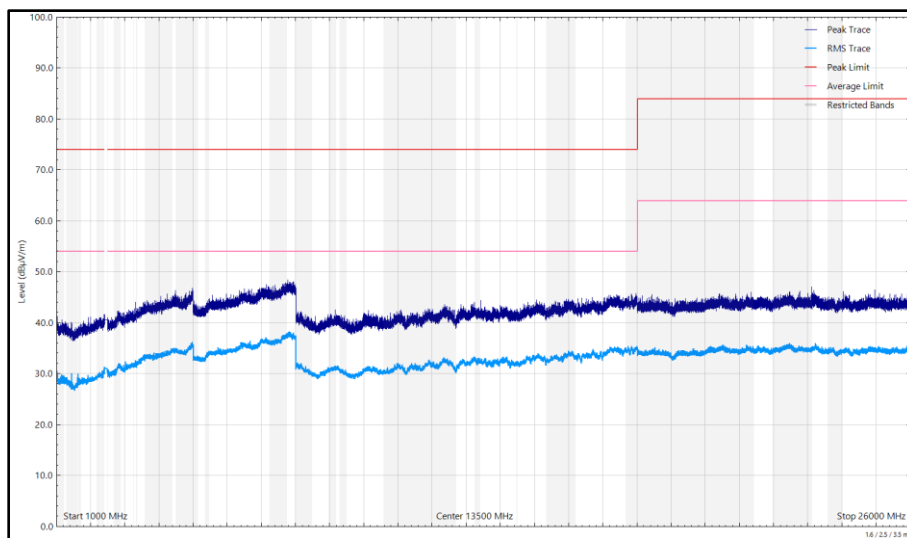

Figure 232 - 2441 MHz (CH39), DH5, iPA, Core 0 + Core 1, 1 GHz to 26 GHz, Horizontal

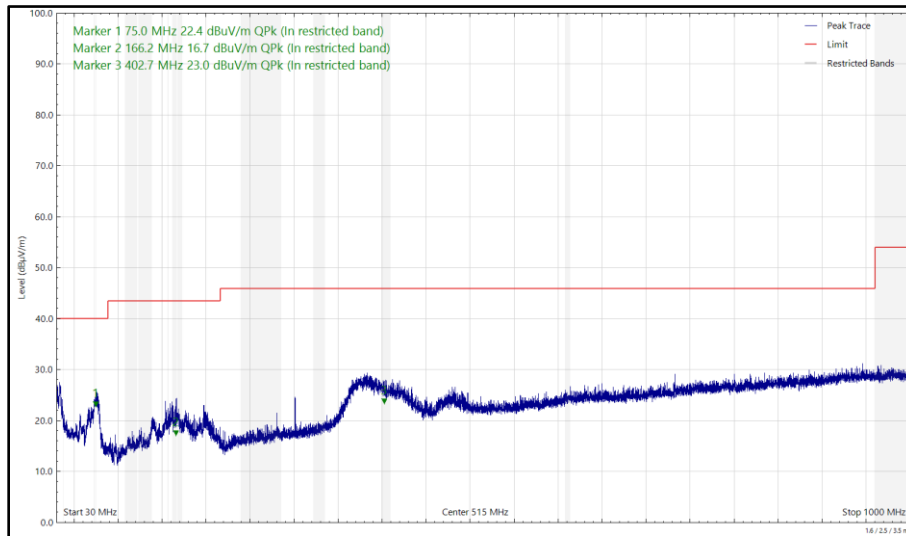

Figure 233 - 2441 MHz (CH39), DH5, iPA, Core 0 + Core 1, 30 MHz to 1 GHz, Vertical (Peak)

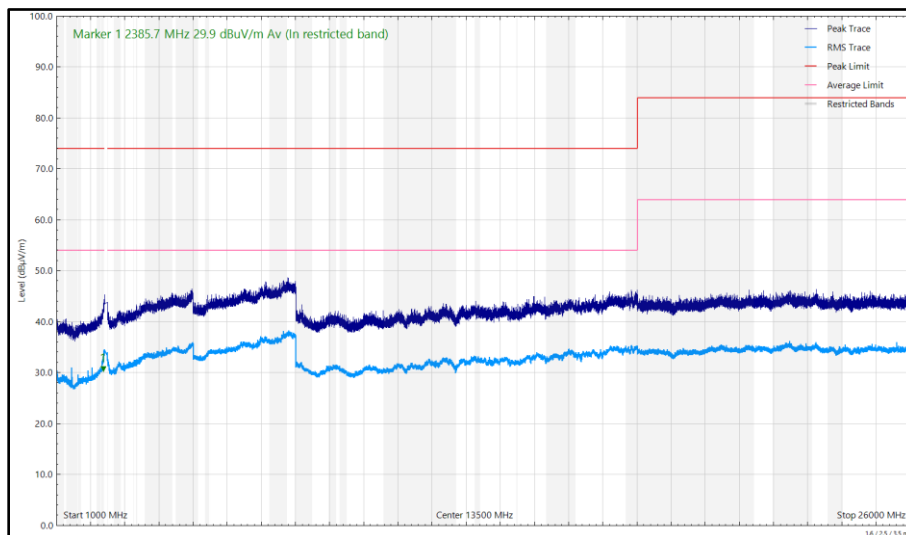

Figure 234 - 2441 MHz (CH39), DH5, iPA, Core 0 + Core 1, 1 GHz to 26 GHz, Vertical



Frequency (MHz)	Level (dBµV/m)	Limit (dBµV/m)	Margin (dB)	Detector	Angle (°)	Height (cm)	Polarisation
2498.984	33.29	54.00	-20.71	CISPR Avg	37	292	Vertical

Table 125 - 2480 MHz (CH78), DH5, iPA, Core 0 + Core 1, 1 GHz to 26 GHz

No other emissions found within 10 dB of the limit.

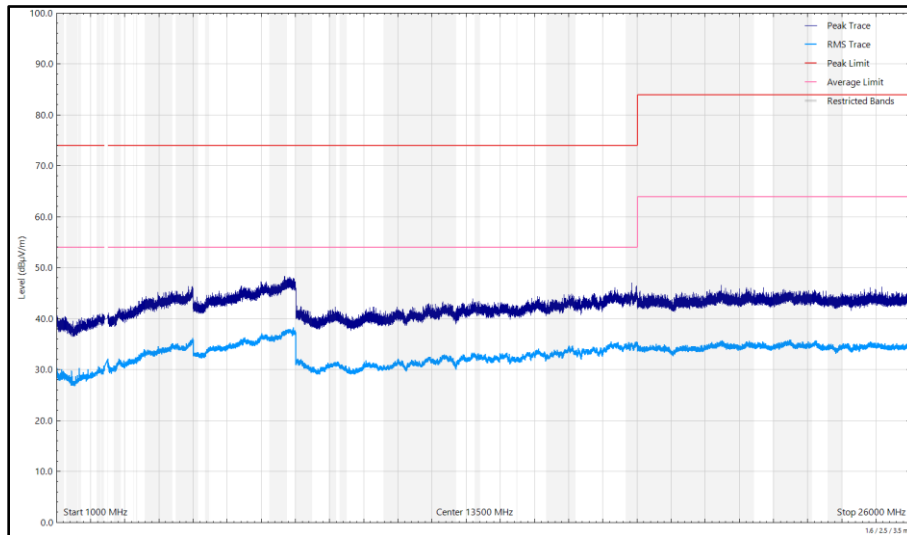

Figure 235 - 2480 MHz (CH78), DH5, iPA, Core 0 + Core 1, 1 GHz to 26 GHz, Horizontal

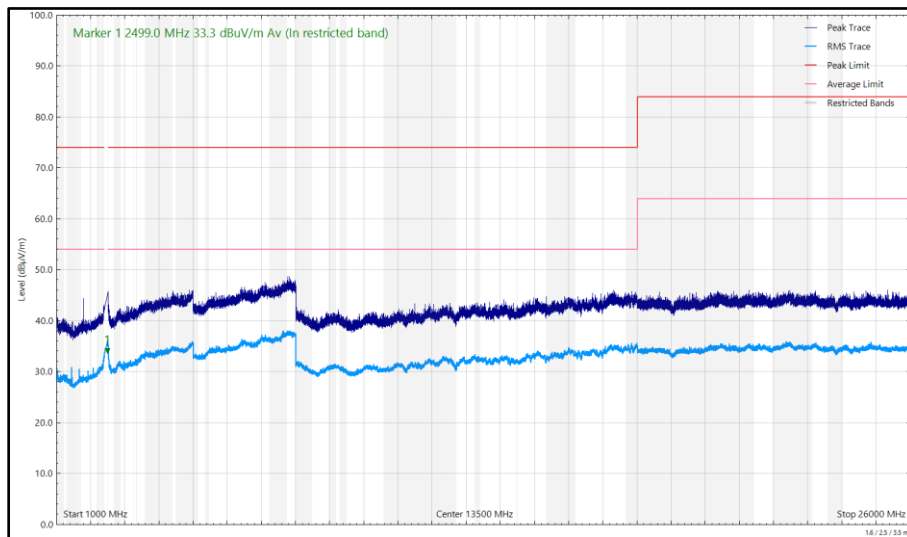

Figure 236 - 2480 MHz (CH78), DH5, iPA, Core 0 + Core 1, 1 GHz to 26 GHz, Vertical



Frequency (MHz)	Level (dBµV/m)	Limit (dBµV/m)	Margin (dB)	Detector	Angle (°)	Height (cm)	Polarisation
*							

Table 126 - 2402 MHz (CH0), DH5, iPA, Core 2, 1 GHz to 26 GHz

*No emissions found within 10 dB of the limit.

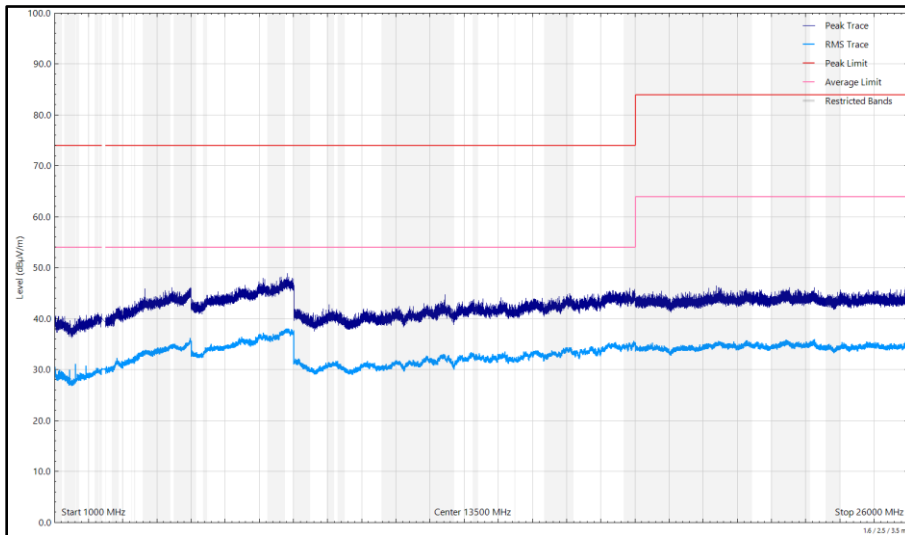

Figure 237 - 2402 MHz (CH0), DH5, iPA, Core 2, 1 GHz to 26 GHz, Horizontal

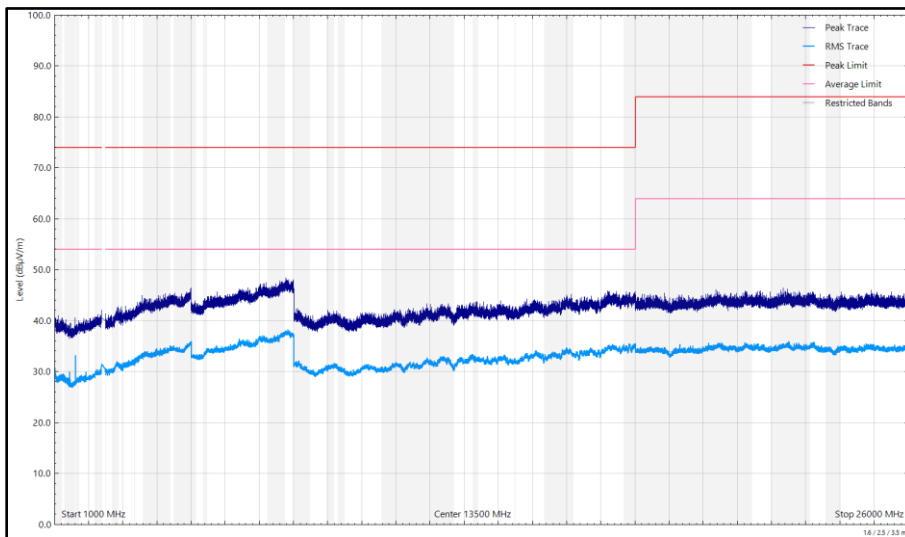

Figure 238 - 2402 MHz (CH0), DH5, iPA, Core 2, 1 GHz to 26 GHz, Vertical



Frequency (MHz)	Level (dBμV/m)	Limit (dBμV/m)	Margin (dB)	Detector	Angle (°)	Height (cm)	Polarisation
74.198	22.86	40.00	-17.14	Q-Peak	67	100	Vertical
165.949	19.28	43.50	-24.22	Q-Peak	244	108	Vertical
166.124	20.41	43.50	-23.09	Q-Peak	2	150	Horizontal
402.375	23.67	46.00	-22.33	Q-Peak	173	110	Vertical

Table 127 - 2441 MHz (CH39), DH5, iPA, Core 2, 30 MHz to 26 GHz

No other emissions found within 10 dB of the limit.

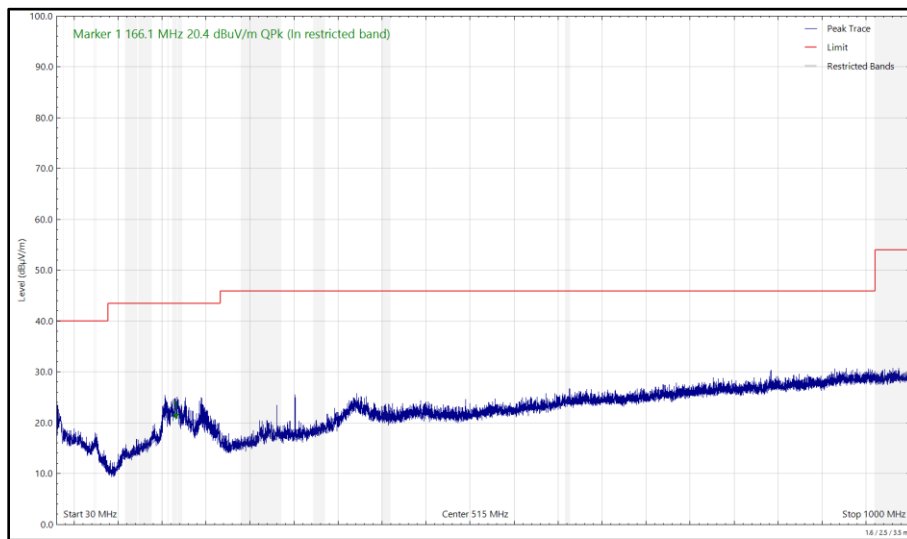

Figure 239 - 2441 MHz (CH39), DH5, iPA, Core 2, 30 MHz to 1 GHz, Horizontal (Peak)

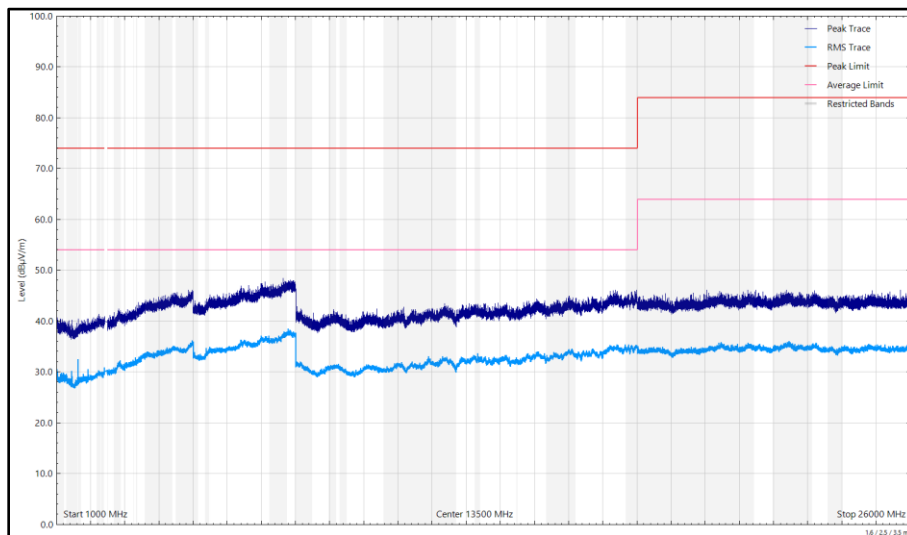

Figure 240 - 2441 MHz (CH39), DH5, iPA, Core 2, 1 GHz to 26 GHz, Horizontal

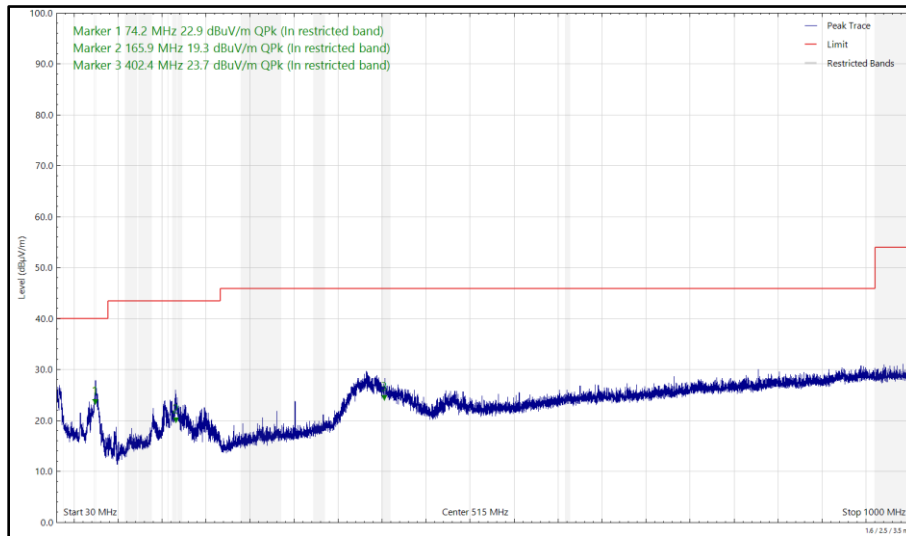

Figure 241 - 2441 MHz (CH39), DH5, iPA, Core 2, 30 MHz to 1 GHz, Vertical (Peak)

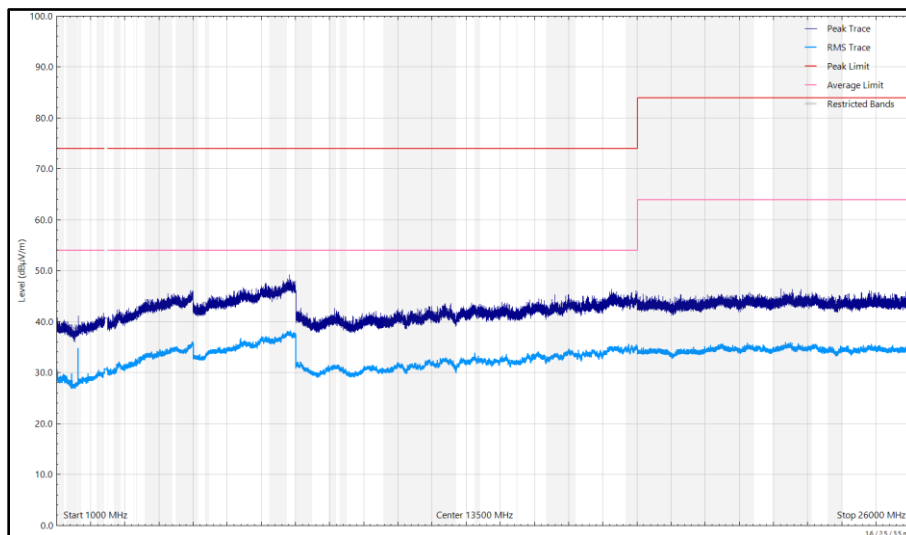

Figure 242 - 2441 MHz (CH39), DH5, iPA, Core 2, 1 GHz to 26 GHz, Vertical



Frequency (MHz)	Level (dBµV/m)	Limit (dBµV/m)	Margin (dB)	Detector	Angle (°)	Height (cm)	Polarisation
*							

Table 128 - 2480 MHz (CH78), DH5, iPA, Core 2, 1 GHz to 26 GHz

*No emissions found within 10 dB of the limit.

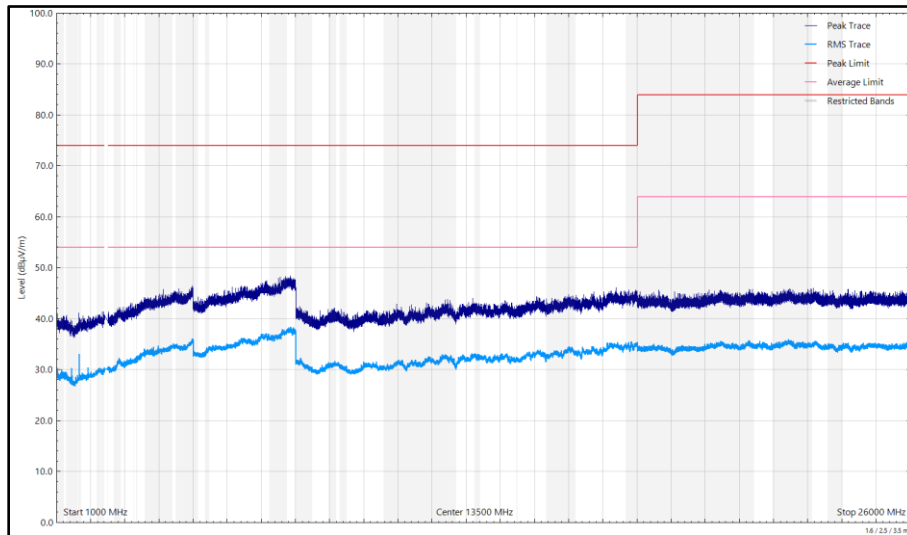

Figure 243 - 2480 MHz (CH78), DH5, iPA, Core 2, 1 GHz to 26 GHz, Horizontal

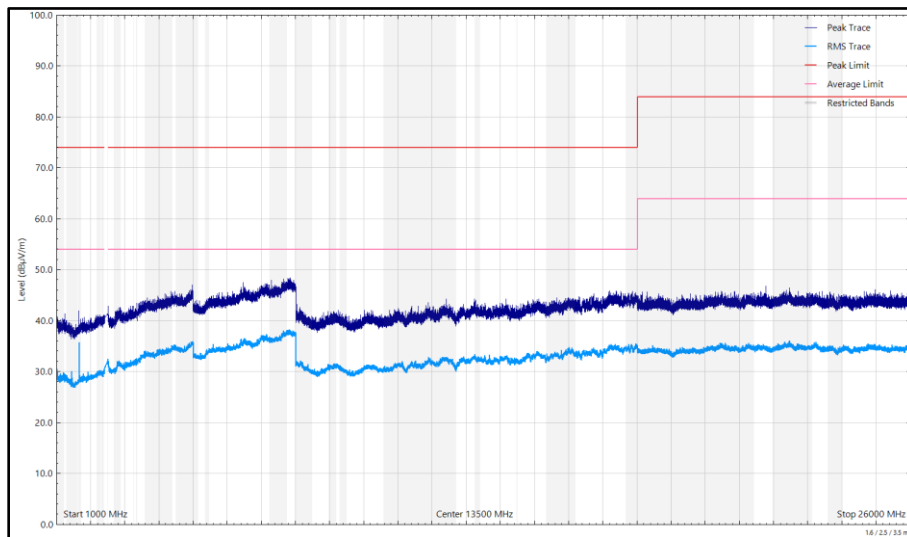

Figure 244 - 2480 MHz (CH78), DH5, iPA, Core 2, 1 GHz to 26 GHz, Vertical



FCC 47 CFR Part 15, Limit Clause 15.247 (d)

In any 100 kHz bandwidth outside the frequency band in which the spread spectrum or digitally modulated intentional radiator is operating, the radio frequency power that is produced by the intentional radiator shall be at least 20 dB below that in the 100 kHz bandwidth within the band that contains the highest level of the desired power, based on either an RF conducted or a radiated measurement, provided the transmitter demonstrates compliance with the peak conducted power limits. If the transmitter complies with the conducted power limits based on the use of RMS averaging over a time interval, as permitted under paragraph (b)(3) of this section, the attenuation required under this paragraph shall be 30 dB instead of 20 dB.

Attenuation below the general limits specified in § 15.209(a) is not required. In addition, radiated emissions which fall in the restricted bands, as defined in § 15.205(a), must also comply with the radiated emission limits specified in 15.209(a).



2.8.8 Test Location and Test Equipment Used

This test was carried out in RF Chamber 18.

Instrument	Manufacturer	Type No.	TE No.	Calibration Period (months)	Calibration Expiry Date
Emissions Software	TUV SUD	EmX V3.2.0	5125	-	Software
Cable (N to N 1m)	Junkosha	MWX221-01000AMSAMS/B	6009	12	20-May-2025
SAC Switch Unit	TUV SUD	TUV_SSU_001	6144	12	11-Dec-2024
Digital Multimeter	Fluke	115	6146	12	06-Jun-2025
8GHz Highpass Filter	Wainwright	WHKX 7150 8000 18000 50SS	6194	12	23-Apr-2025
Pre Amp 8 - 18 GHz	Wright Technologies	APS06 0061	6200	12	03-Jun-2025
Attenuator 4dB	Pasternack	PE7074-4	6204	24	20-Jun-2026
Cable (SMA to SMA 20cm)	TUV SUD	MH-FH 8-18	6215	12	23-Apr-2025
Cable (SMA to SMA 8m)	Junkosha	MWX221-08000AMSAMS/B	6318	12	18-Feb-2025
Cable (K Type 2m)	Junkosha	MWX241-02000KMSKMS/B	6323	12	04-Feb-2025
EMC Test Receiver	Rohde & Schwarz	ESW44	6333	12	16-Feb-2025
Trilog Super Broadband Test Antenna	Schwarzbeck	VULB 9168	6456	24	10-Feb-2025
DRG Horn Antenna (8-18 GHz)	Schwarzbeck	HWRD750	6458	12	05-May-2025
Humidity and Temperature Meter	R.S Components	1364	6486	12	04-Jun-2025
3m Semi-Anechoic Chamber	Albatross Projects	Chamber 18	6597	36	07-Feb-2026
Double Ridge Active Horn Antenna (18-40 GHz)	Com-Power	AHA-840	6771	24	17-Jan-2025
Mast & Turntable Controller	Maturo Gmbh	FCU3.0	6795	-	TU
Tilt Antenna Mast	Maturo Gmbh	BAM4.5-P	6796	-	TU
Turntable	Maturo Gmbh	TT1.5SI	6797	-	TU
AC Programmable Power Supply	iTech	IT7324	6812	-	O/P Mon
Broad-Band Horn Antenna 1-10GHz N	Schwarzbeck	BBHA9120B	6825	12	18-Jul-2025

Table 129

TU - Traceability Unscheduled

O/P Mon - Output Monitored using calibrated equipment



3 Measurement Uncertainty

For a 95% confidence level, the measurement uncertainties for defined systems are:

Test Name	Measurement Uncertainty
Restricted Band Edges	30 MHz to 1 GHz: ± 5.2 dB 1 GHz to 40 GHz: ± 6.3 dB
Frequency Hopping Systems - Average Time of Occupancy	-
Frequency Hopping Systems - Channel Separation	± 42.30 kHz
Frequency Hopping Systems - Number of Hopping Channels	-
Frequency Hopping Systems - 99% & 20 dB Bandwidth	± 45.99 kHz
Maximum Conducted Output Power	± 1.38 dB
Authorised Band Edges	30 MHz to 1 GHz: ± 5.2 dB 1 GHz to 40 GHz: ± 6.3 dB
Spurious Radiated Emissions	30 MHz to 1 GHz: ± 5.2 dB 1 GHz to 40 GHz: ± 6.3 dB

Table 130

Measurement Uncertainty Decision Rule – Accuracy Method

Determination of conformity with the specification limits is based on the decision rule according to IEC Guide 115:2021, Clause 4.4.3 (Procedure 2). The measurement results are directly compared with the test limit to determine conformance with the requirements of the standard.

Risk: The uncertainty of measurement about the measured result is negligible with regard to the final pass/fail decision. The measurement result can be directly compared with the test limit to determine conformance with the requirement (compare IEC Guide 115). The level of risk to falsely accept and falsely reject items is further described in ILAC-G8.