

FCC and ISED Test Report

Apple Inc
Model: A3112



In accordance with FCC 47 CFR Part 15C,
ISED RSS-247 and ISED RSS-GEN
(Thread)

Prepared for: Apple Inc
One Apple Park Way
Cupertino
California
95014
USA

FCC ID: BCGA3112

IC: 579C-A3112

COMMERCIAL-IN-CONFIDENCE

Document 75959702-16 Issue 01

SIGNATURE

NAME	JOB TITLE	RESPONSIBLE FOR	ISSUE DATE
Steve White	Senior Technical Specialist	Authorised Signatory	21 August 2024

Signatures in this approval box have checked this document in line with the requirements of TÜV SÜD document control rules.

ENGINEERING STATEMENT

The measurements shown in this report were made in accordance with the procedures described on test pages. All reported testing was carried out on a sample equipment to demonstrate limited compliance with FCC 47 CFR Part 15C, ISED RSS-247 and ISED RSS-GEN. The sample tested was found to comply with the requirements defined in the applied rules.

RESPONSIBLE FOR	NAME	DATE	SIGNATURE
Report Generation	Lauren Walters	21 August 2024	

FCC Accreditation

553713/UK2026 Concorde Park, Fareham Test Laboratory

ISED Accreditation

28798/UK0003 Concorde Park, Fareham Test Laboratory

EXECUTIVE SUMMARY

A sample of this product was tested and found to be compliant with FCC 47 CFR Part 15C: 2023, ISED RSS-247: Issue 3 (08-2023) and ISED RSS-GEN: Issue 5 (04-2018) + A2 (02-2021) for the tests detailed in section 1.3.



DISCLAIMER AND COPYRIGHT

This non-binding report has been prepared by TÜV SÜD with all reasonable skill and care. The document is confidential to the potential Client and TÜV SÜD. No part of this document may be reproduced without the prior written approval of TÜV SÜD. © 2024 TÜV SÜD. This report relates only to the actual item/items tested.

ACCREDITATION

Our UKAS Accreditation does not cover opinions and interpretations and any expressed are outside the scope of our UKAS Accreditation. Results of tests not covered by our UKAS Accreditation Schedule are marked NUA (Not UKAS Accredited). Results of tests covered by our Flexible UKAS Accreditation Schedule are marked FS (Flexible Scope).

TÜV SÜD
is a trading name of TÜV SÜD Ltd
Registered in Scotland at East Kilbride,
Glasgow G75 0QF, United Kingdom
Registered number: SC215164

TÜV SÜD Ltd is a
TÜV SÜD Group Company

Phone: +44 (0) 1489 558100
Fax: +44 (0) 1489 558101
www.tuvsud.com/en

TÜV SÜD
Octagon House
Concorde Way
Fareham
Hampshire PO15 5RL
United Kingdom



Contents

1	Report Summary	2
1.1	Report Modification Record.....	2
1.2	Introduction.....	2
1.3	Brief Summary of Results	3
1.4	Product Information	4
1.5	Deviations from the Standard.....	5
1.6	Identification of the EUT	5
1.7	EUT Modification Record	5
1.8	Test Location	6
2	Test Details	7
2.1	Restricted Band Edges.....	7
2.2	Emission Bandwidth	15
2.3	Maximum Conducted Output Power	27
2.4	Authorised Band Edges	34
2.5	Spurious Radiated Emissions	41
2.6	Power Spectral Density	66
3	Measurement Uncertainty	71



1 Report Summary

1.1 Report Modification Record

Alterations and additions to this report will be issued to the holders of each copy in the form of a complete document.

Issue	Description of Change	Date of Issue
1	First Issue	21-Aug-2024

Table 1

1.2 Introduction

Applicant	Apple Inc
Manufacturer	Apple Inc
EUT/Sample Identification	Refer to section 1.6
Test Specification/Issue/Date	FCC 47 CFR Part 15C: 2023 ISED RSS-247: Issue 3 (2023-08) ISED RSS-GEN: Issue 5 (2018-04) + A2 (2021-02)
Start of Test	10-June-2024
Finish of Test	15-July-2024
Name of Engineer(s)	Colin Brain, Tony Baby, Mustafa Murad, Dale Hills, Ian Hart, James Woods, Morsalin Hossain and Thomas Randall
Related Document(s)	ANSI C63.10 (2020)



1.3 Brief Summary of Results

A brief summary of the tests carried out in accordance with FCC 47 CFR Part 15C, ISED RSS-247 and ISED RSS-GEN is shown below.

Section	Specification Clause			Test Description	Result	Comments/Base Standard
	Part 15C	RSS-247	RSS-GEN			
Configuration and Mode: Thread						
-	15.203	-	-	Antenna Requirement	N/T	The device complies with the provisions of this section, as it uses permanently attached integral antennas.
2.1	15.205	3.3	8.10	Restricted Band Edges	Pass	ANSI C63.10 (2020)
2.2	15.247 (a)(2)	5.2	6.7	Emission Bandwidth	Pass	ANSI C63.10 (2020)
2.3	15.247 (b)	5.4	6.12	Maximum Conducted Output Power	Pass	ANSI C63.10 (2020)
2.4	15.247 (d)	5.5	-	Authorised Band Edges	Pass	ANSI C63.10 (2020)
2.5	15.209 and 15.247 (d)	3.3 and 5.5	6.13 and 8.9	Spurious Radiated Emissions	Pass	ANSI C63.10 (2020)
2.6	15.247 (e)	5.2	6.12	Power Spectral Density	Pass	ANSI C63.10 (2020)

Table 2



1.4 Product Information

1.4.1 Technical Description

The equipment under test (EUT) was a portable laptop computer.

1.4.2 Test Modes

The EUT's 2.4 GHz Thread radio supports SISO operation on three different cores. Thread operation does not support any MIMO modes.

It also operates at two power settings: low power "iPA" and high power "ePA", except for core 2 which only supports the lower power mode.

The EUT uses different output powers per core for each power setting and the antenna gains vary, resulting in a different radiated power per core.

The EUT was tested in the following modes:

SISO modes:

- iPA Core 0
- iPA Core 1
- iPA Core 2
- ePA Core 0
- ePA Core 1

1.4.3 Test Setup

For conducted tests the EUT antennas were disconnected and replaced with U.FL to SMA test cables to enable conducted testing on each core. The loss of these test cables were known and compensated for in any conducted measurements.

For all tests the EUT was put into a continuous transmit/receive test mode with the chipset manufacturer's test commands to ensure the measured signals were representative.

All testing was performed with the EUT powered via a 120 V AC, 60 Hz source.

1.4.4 Antenna Gain Table

Antenna Port	Frequency Range (MHz)	Peak Gain (dBi)	Conducted Cable Loss (dB)
Core 0	2400 to 2480	4.6	0.71
Core 1	2400 to 2480	4.2	0.71
Dedicated Core 2	2400 to 2480	4.3	0.71

Table 3



1.5 Deviations from the Standard

No deviations from the applicable test standard were made during testing.

1.6 Identification of the EUT

The table below details identification of the EUT(s) that have been used to carry out the testing within this report.

Model: A3112			
Serial Number	Hardware Version	Software Version	Firmware
D2XW4JQFNK	REV1.0	24A21940x	22.1.65.459
MNV254CLPF	REV1.0	24A21940x	22.1.65.459
K67X45QH3Q	REV1.0	24A21940x	22.1.65.459
DQHQ6Q99MH	REV1.0	24A21940x	22.1.65.459

Table 4

1.7 EUT Modification Record

The table below details modifications made to the EUT during the test programme.

The modifications incorporated during each test are recorded on the appropriate test pages.

Modification State	Description of Modification still fitted to EUT	Modification Fitted By	Date Modification Fitted
Model: A3112, Serial Number: K67X45QH3Q			
0	As supplied by the customer	Not Applicable	Not Applicable
Model: A3112, Serial Number: D2XW4JQFNK			
0	As supplied by the customer	Not Applicable	Not Applicable
Model: A3112, Serial Number: MNV254CLPF			
0	As supplied by the customer	Not Applicable	Not Applicable
Model: A3112, Serial Number: DQHQ6Q99MH			
0	As supplied by the customer	Not Applicable	Not Applicable

Table 5



1.8 Test Location

TÜV SÜD conducted the following tests at our Concorde Park Test Laboratory.

Test Name	Name of Engineer(s)	Accreditation
Configuration and Mode: Thread		
Restricted Band Edges	Colin Brain and Tony Baby	UKAS
Emission Bandwidth	Mustafa Murad	UKAS
Maximum Conducted Output Power	Mustafa Murad	UKAS
Authorised Band Edges	Colin Brain and Tony Baby	UKAS
Spurious Radiated Emissions	Colin Brain, Dale Hills, Ian Hart, James Woods, Morsalin Hossain and Thomas Randall	UKAS
Power Spectral Density	Mustafa Murad	UKAS

Table 6

Office Address:

TÜV SÜD
Concorde Park
Concorde Way
Fareham
Hampshire
PO15 5FG
United Kingdom



2 Test Details

2.1 Restricted Band Edges

2.1.1 Specification Reference

FCC 47 CFR Part 15C, Clause 15.205
ISED RSS-247, Clause 3.3
ISED RSS-GEN, Clause 8.10

2.1.2 Equipment Under Test and Modification State

A3112, S/N: K67X45QH3Q - Modification State 0

2.1.3 Date of Test

10-June-2024 to 11-June-2024

2.1.4 Test Method

This test was performed in accordance with ANSI C63.10, clause 6.10.5 and 11.12.1.

Plots for average measurements were taken in accordance with ANSI C63.10, clause 11.12.2.5.2.

The following conversion can be applied to convert from dB μ V/m to μ V/m:
 $10^{(\text{Field Strength in dB}\mu\text{V/m}/20)}$.

2.1.5 Environmental Conditions

Ambient Temperature	23.0 - 23.1 °C
Relative Humidity	40.8 - 42.7 %



2.1.6 Test Results

Thread

iPA - Core 0 (SISO)

Mode	TX Frequency (MHz)	Band Edge Frequency (MHz)	Peak Level (dBμV/m)	Average Level (dBuV/m)
Thread	2405	2390	55.92	43.27
Thread	2475	2483.5	53.66	41.97

Table 7 - iPA, Core 0, SISO Restricted Band Edge Results

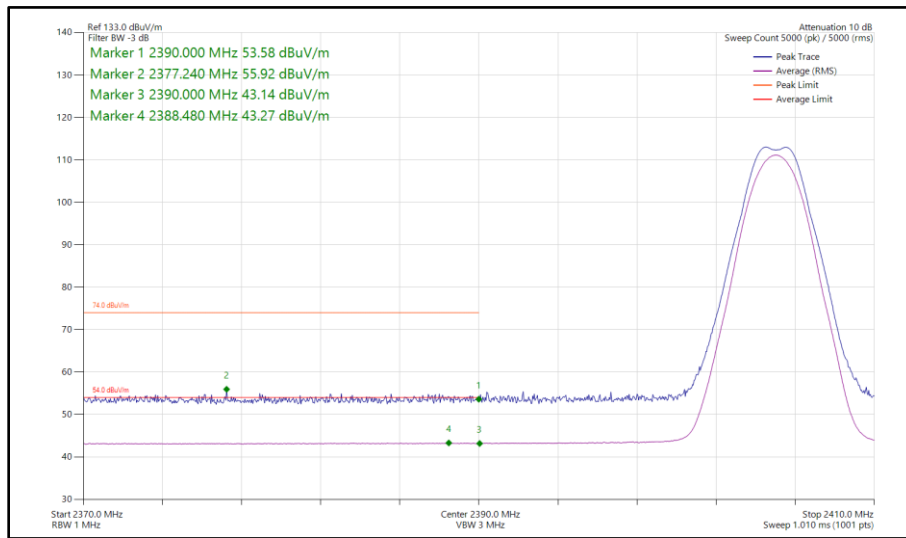

**Figure 1 - Thread, iPA, SISO, Core 0 - 2405 MHz
 Band Edge Frequency 2390 MHz**

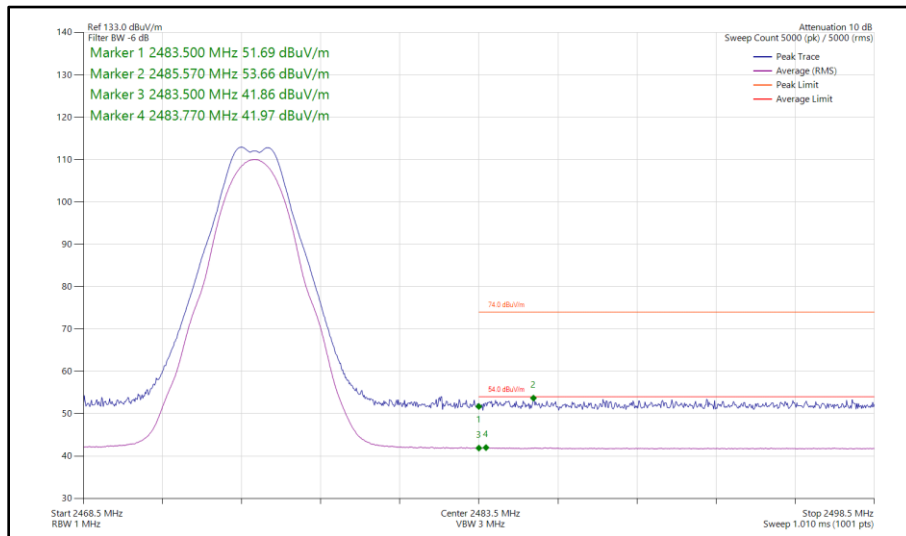

**Figure 2 - Thread, iPA, SISO, Core 0 - 2475 MHz
 Band Edge Frequency 2483.5 MHz**



iPA - Core 1 (SISO)

Mode	TX Frequency (MHz)	Band Edge Frequency (MHz)	Peak Level (dBμV/m)	Average Level (dBμV/m)
Thread	2405	2390	55.65	43.31
Thread	2475	2483.5	54.22	41.98

Table 8 - iPA, Core 1, SISO Restricted Band Edge Results

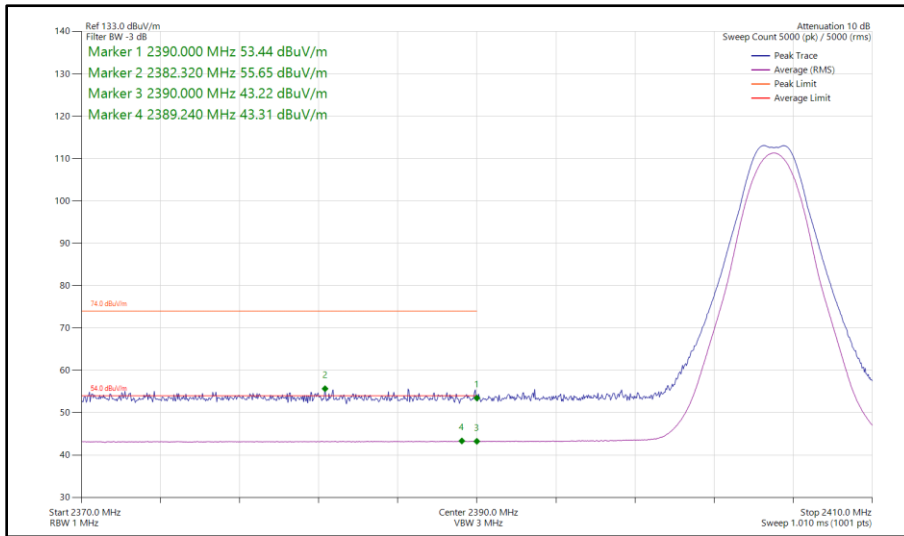

**Figure 3 - Thread, iPA, SISO, Core 1 - 2405 MHz
 Band Edge Frequency 2390 MHz**

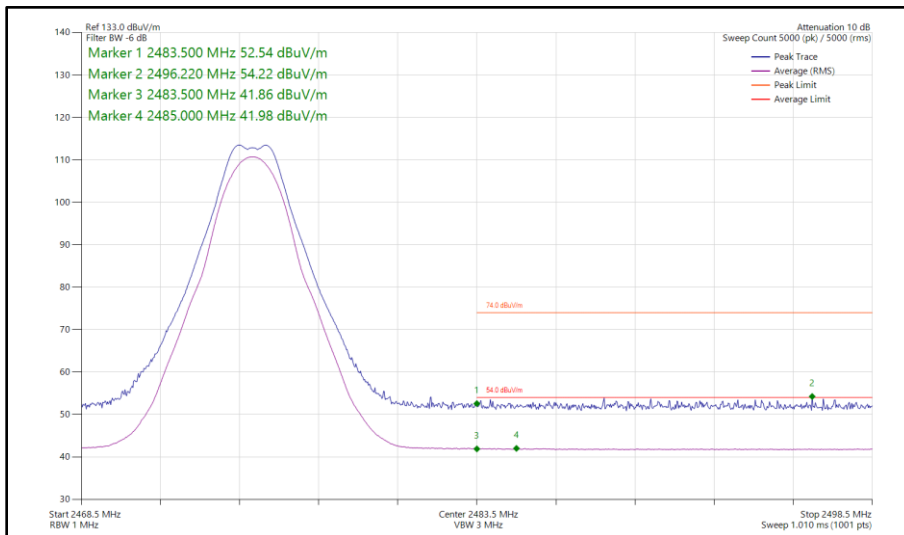

**Figure 4 - Thread, iPA, SISO, Core 1 - 2475 MHz
 Band Edge Frequency 2483.5 MHz**



iPA - Core 2 (SISO)

Mode	TX Frequency (MHz)	Band Edge Frequency (MHz)	Peak Level (dB μ V/m)	Average Level (dB μ V/m)
Thread	2405	2390	55.38	43.26
Thread	2475	2483.5	54.13	42.08

Table 9 - iPA, Core 2, SISO Restricted Band Edge Results

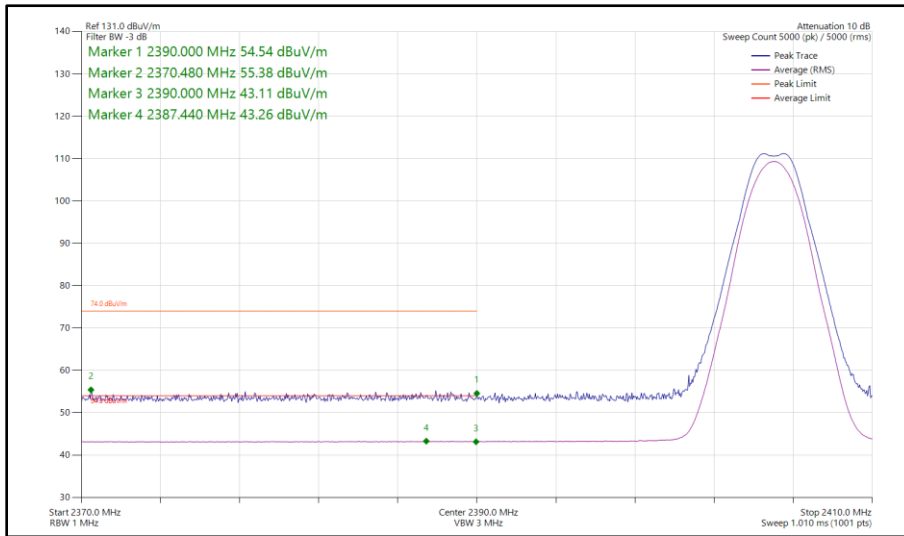

**Figure 5 - Thread, iPA, SISO, Core 2 - 2405 MHz
 Band Edge Frequency 2390 MHz**

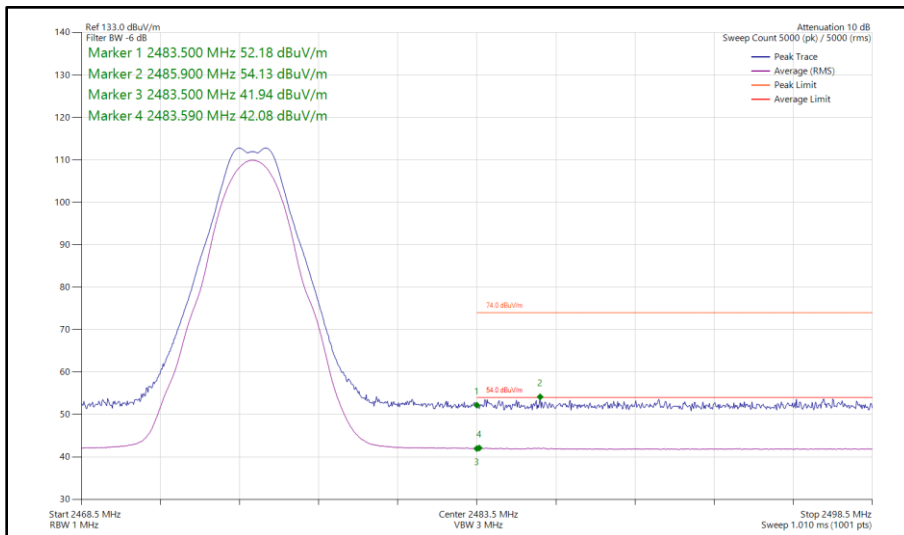

**Figure 6 - Thread, iPA, SISO, Core 2 - 2475 MHz
 Band Edge Frequency 2483.5 MHz**



ePA - Core 0 (SISO)

Mode	TX Frequency (MHz)	Band Edge Frequency (MHz)	Peak Level (dB μ V/m)	Average Level (dB μ V/m)
Thread	2405	2390	56.99	45.46
Thread	2475	2483.5	57.18	44.71

Table 10 - ePA, Core 0, SISO Restricted Band Edge Results

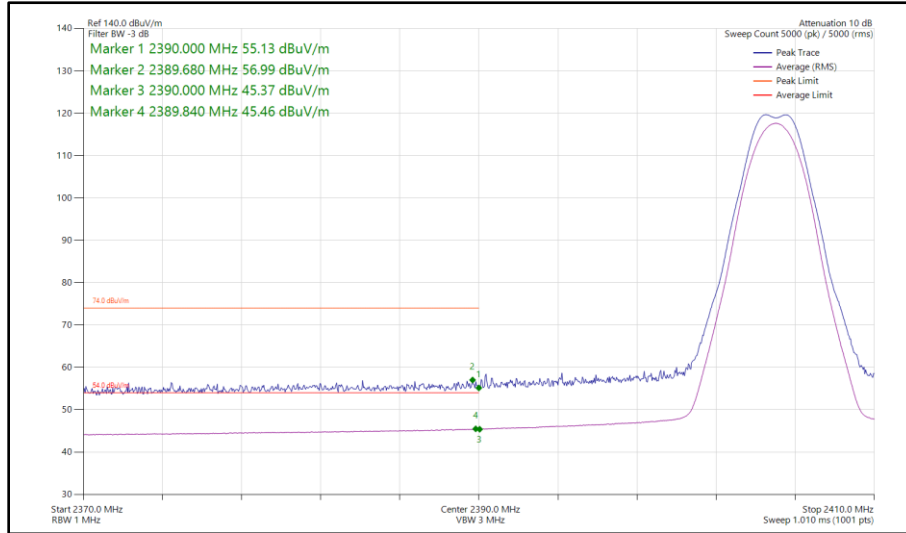

Figure 7 - Thread, ePA, SISO, Core 0 - 2405 MHz
 Band Edge Frequency 2390 MHz

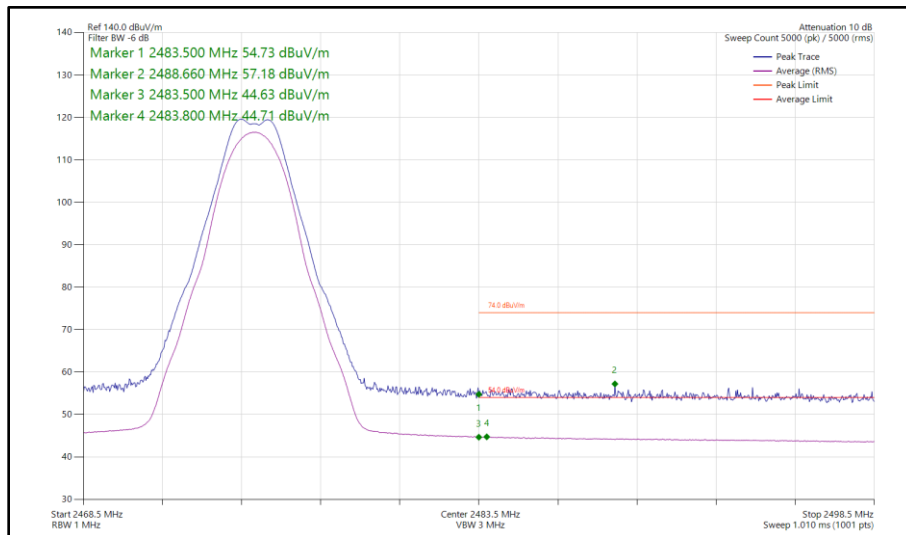

Figure 8 - Thread, ePA, SISO, Core 0 - 2475 MHz
 Band Edge Frequency 2483.5 MHz



ePA - Core 1 (SISO)

Mode	TX Frequency (MHz)	Band Edge Frequency (MHz)	Peak Level (dBμV/m)	Average Level (dBμV/m)
Thread	2405	2390	57.68	45.57
Thread	2475	2483.5	57.00	45.65

Table 11 - ePA, Core 1, SISO Restricted Band Edge Results

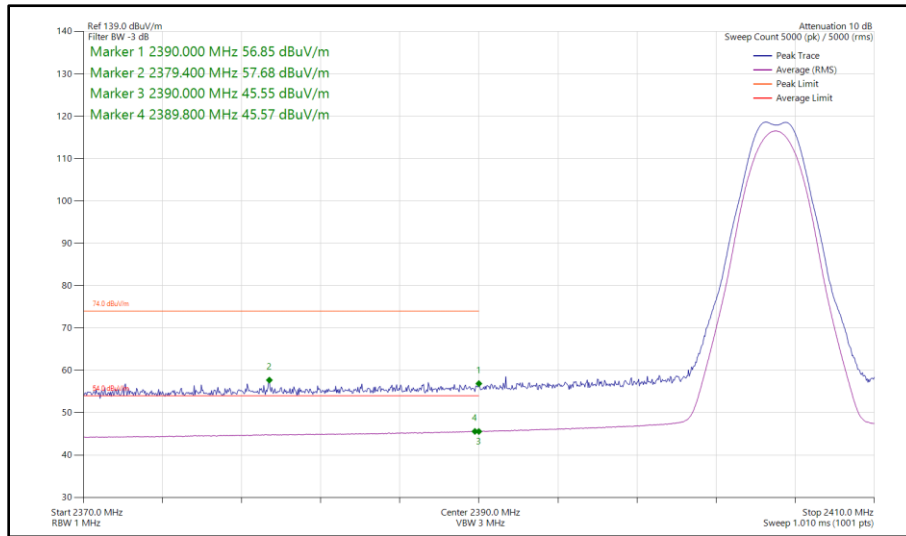

Figure 9 - Thread, ePA, SISO, Core 1 - 2405 MHz
 Band Edge Frequency 2390 MHz

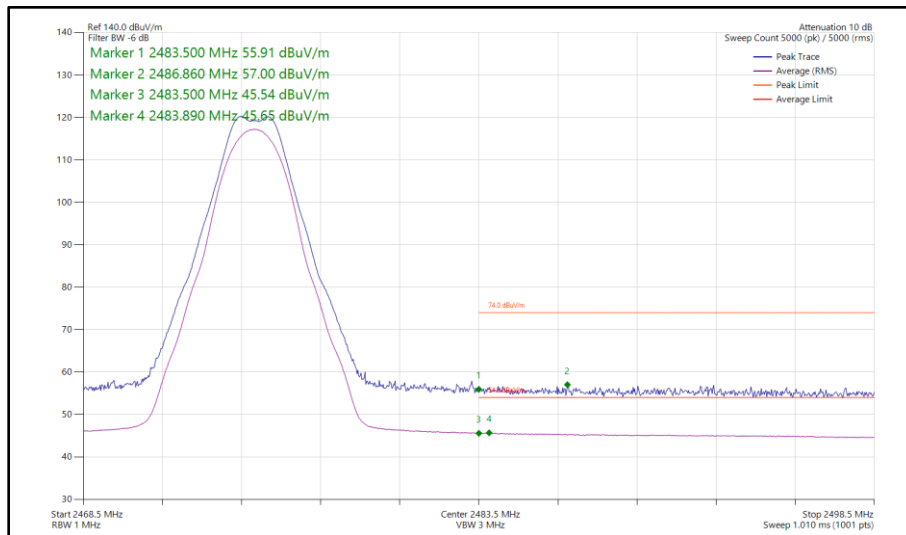

Figure 10 - Thread, ePA, SISO, Core 1 - 2475 MHz
 Band Edge Frequency 2483.5 MHz



FCC 47 CFR Part 15, Limit Clause 15.209

Frequency (MHz)	Field Strength ($\mu\text{V}/\text{m}$ at 3 m)
30 to 88	100
88 to 216	150
216 to 960	200
Above 960	500

Table 12

ISED RSS-GEN, Limit Clause 8.9

Frequency (MHz)	Field Strength ($\mu\text{V}/\text{m}$ at 3 m)
30 to 88	100
88 to 216	150
216 to 960	200
Above 960*	500

Table 13

*Unless otherwise specified, for all frequencies greater than 1 GHz, the radiated emission limits for licence-exempt radio apparatus stated in applicable RSSs (including RSS-Gen) are based on measurements using a linear average detector function having a minimum resolution bandwidth of 1 MHz. If an average limit is specified for the EUT, then the peak emission shall also be measured with instrumentation properly adjusted for such factors as pulse desensitization to ensure the peak emission is less than 20 dB above the average limit.



2.1.7 Test Location and Test Equipment Used

This test was carried out in RF Chamber 15.

Instrument	Manufacturer	Type No.	TE No.	Calibration Period (months)	Calibration Expiry Date
Emissions Software	TUV SUD	EmX V3.2.0	5125	-	Software
EMI Test Receiver	Rohde & Schwarz	ESW44	5911	12	11-Sep-2024
1500W (300V 12A) AC Power Supply	iTech	IT7324	5955	-	O/P Mon
5m Semi-Anechoic Chamber (Dual-Axis), Chamber 15	Albatross Projects	RF Chamber 15	5963	36	28-Apr-2025
Compact Antenna Mast	Maturo Gmbh	CAM4.0-P	5964	-	TU
Mast & Turntable Controller	Maturo Gmbh	FCU3.0	5966	-	TU
Tilt Antenna Mast	Maturo Gmbh	BAM4.5-P	5967	-	TU
Turntable	Maturo Gmbh	TT1.5SI	5968	-	TU
Cable (SMA to SMA 1m)	Junkosha	MWX221-01000AMSAMS/A	5997	12	14-Sep-2024
Cable (N to N 1m)	Junkosha	MWX221-01000AMSAMS/B	6009	12	20-May-2025
Horn Antenna (1-10 GHz)	Schwarzbeck	BBHA9120B	6140	12	05-May-2025
Horn Antenna (1-10 GHz)	Schwarzbeck	BBHA9120B	6142	12	05-May-2025
Digital Multimeter	Fluke	115	6147	12	06-Jun-2025
SAC Switch Unit	TUV SUD	TUV_SSU_001	6191	12	18-Dec-2024
Humidity and Temperature Meter	R.S Components	1364	6486	12	04-Jun-2025
1m Cable	Junkosha	MWX241-01000AMSAMS/B	6740	12	01-Feb-2025
6.5m Cable	Junkosha	MWX221-06500AMSAMS/B	6744	12	01-Feb-2025

Table 14

TU - Traceability Unscheduled

O/P Mon - Output Monitored using calibrated equipment



2.2 Emission Bandwidth

2.2.1 Specification Reference

FCC 47 CFR Part 15C, Clause 15.247 (a)(2)
ISED RSS-247, Clause 5.2
ISED RSS-GEN, Clause 6.7

2.2.2 Equipment Under Test and Modification State

A3112, S/N: DQHQ6Q99MH - Modification State 0

2.2.3 Date of Test

15-July-2024

2.2.4 Test Method

This test was performed in accordance with ANSI C63.10, clause 11.8.1 for 6 dB BW and 6.9.3 for 99% occupied bandwidth measurements.

2.2.5 Environmental Conditions

Ambient Temperature	20.3 °C
Relative Humidity	55.5 %



2.2.6 Test Results

Thread

Test Configuration			
Frequency Range:	2400-2483.5 MHz	Band:	2.4 GHz
Limit Clause(s):	15.247 (a)(2) RSS-247 5.2 a)	Test Method(s):	C63.10 6.9.3 C63.10 11.8.1
Additional Reference(s):	-		

DUT Configuration			
Mode:	Thread iPA	Duty Cycle (%):	-
Data Rate:	-	DCCF (dB):	-
Antenna Configuration:	SISO	Peak Antenna Gain (dBi):	-
Active Port(s):	A (Core 0)	Active Chain(s):	0

Test Frequency (MHz)	6 dB Bandwidth (MHz)				Limit (kHz)
	A	B	C	D	
2405	1.600	-	-	-	≥500.0
2440	1.590	-	-	-	≥500.0
2475	1.610	-	-	-	≥500.0

Table 15 - 6 dB Bandwidth Results

Test Frequency (MHz)	99% Bandwidth (MHz)				Limit (kHz)
	A	B	C	D	
2405	2.330	-	-	-	-
2440	2.340	-	-	-	-
2475	2.330	-	-	-	-

Table 16 - 99% Bandwidth Results

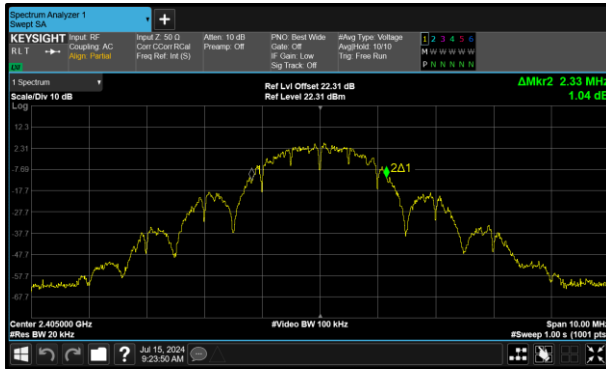

Figure 11 - Core 0 (A) 2405 MHz (CH11) 99% Bandwidth

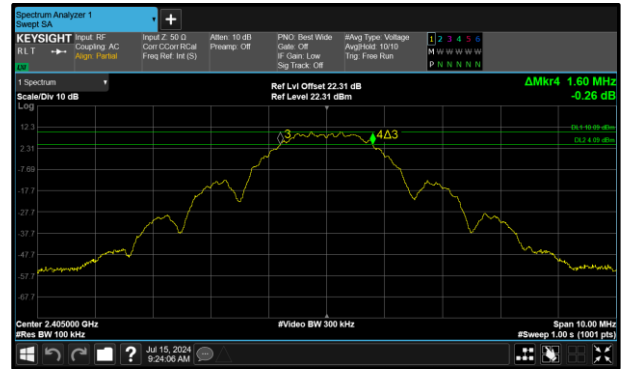

Figure 12 - Core 0 (A) 2405 MHz (CH11) 6 dB Bandwidth

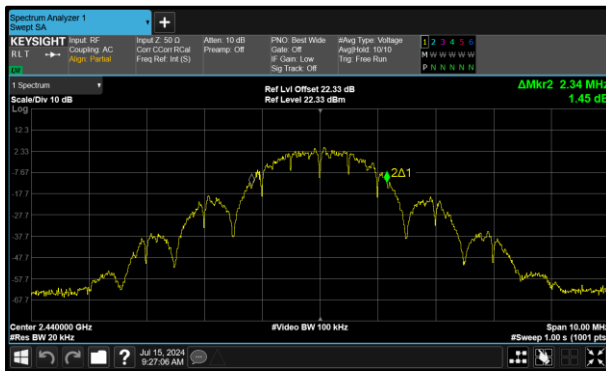

Figure 13 - Core 0 (A) 2440 MHz (CH18) 99% Bandwidth

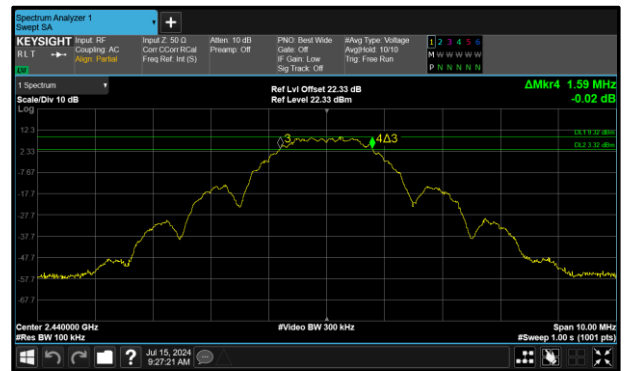

Figure 14 - Core 0 (A) 2440 MHz (CH18) 6 dB Bandwidth

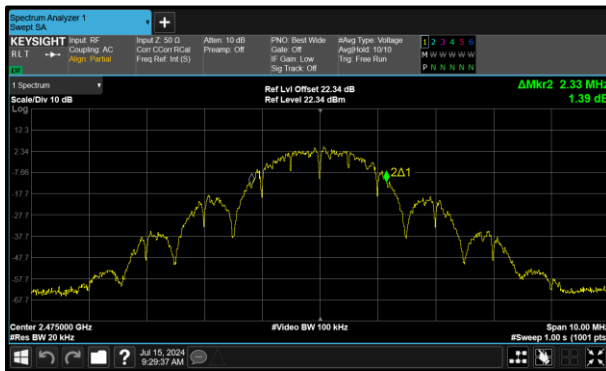

Figure 15 - Core 0 (A) 2475 MHz (CH25) 99% Bandwidth

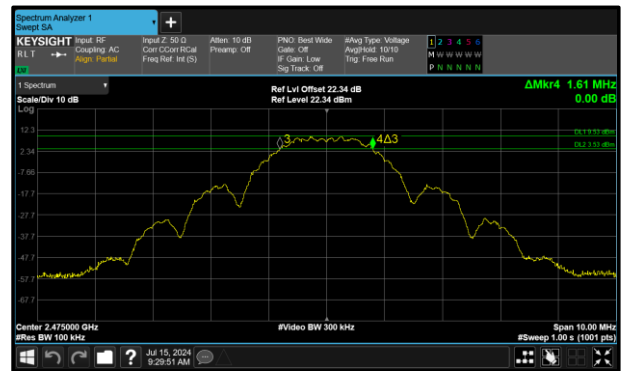

Figure 16 - Core 0 (A) 2475 MHz (CH25) 6 dB Bandwidth



Test Configuration			
Frequency Range:	2400-2483.5 MHz	Band:	2.4 GHz
Limit Clause(s):	15.247 (a)(2) RSS-247 5.2 a)	Test Method(s):	C63.10 6.9.3 C63.10 11.8.1
Additional Reference(s):	-		

DUT Configuration			
Mode:	Thread ePA	Duty Cycle (%):	-
Data Rate:	-	DCCF (dB):	-
Antenna Configuration:	SISO	Peak Antenna Gain (dBi):	-
Active Port(s):	A (Core 0)	Active Chain(s):	0

Test Frequency (MHz)	6 dB Bandwidth (MHz)				Limit (kHz)
	A	B	C	D	
2405	1.610	-	-	-	≥500.0
2440	1.610	-	-	-	≥500.0
2475	1.590	-	-	-	≥500.0

Table 17 - 6 dB Bandwidth Results

Test Frequency (MHz)	99% Bandwidth (MHz)				Limit (kHz)
	A	B	C	D	
2405	2.350	-	-	-	-
2440	2.340	-	-	-	-
2475	2.350	-	-	-	-

Table 18 - 99% Bandwidth Results

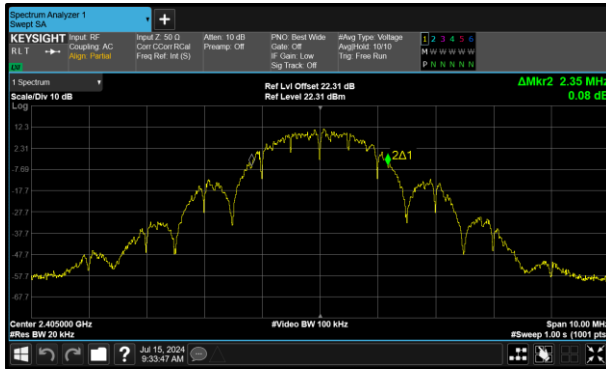

Figure 17 - Core 0 (A) 2405 MHz (CH11) 99% Bandwidth

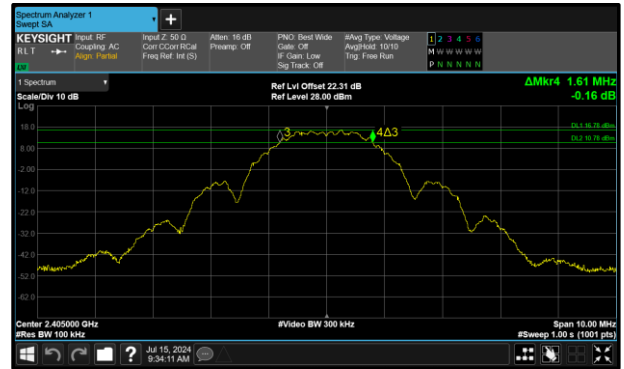

Figure 18 - Core 0 (A) 2405 MHz (CH11) 6 dB Bandwidth

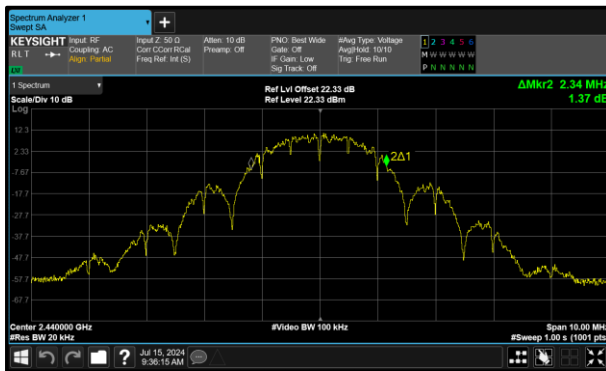

Figure 19 - Core 0 (A) 2440 MHz (CH18) 99% Bandwidth

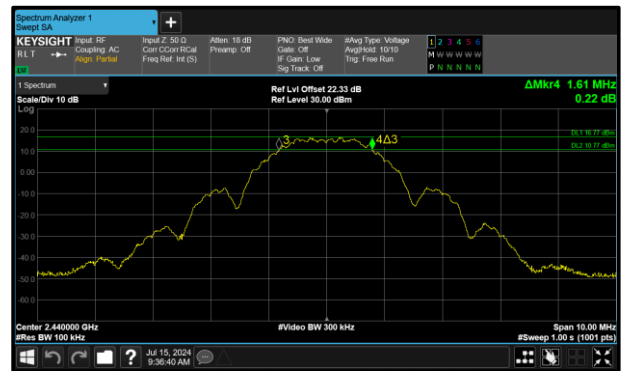

Figure 20 - Core 0 (A) 2440 MHz (CH18) 6 dB Bandwidth

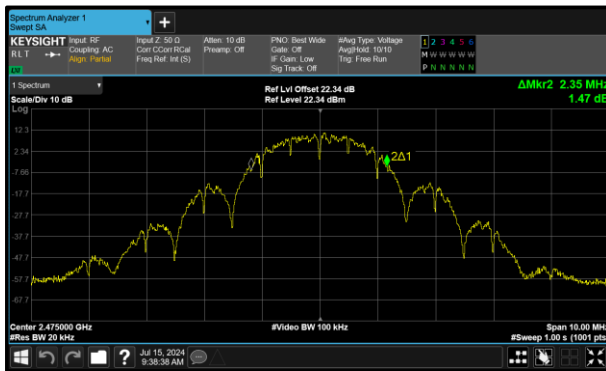

Figure 21 - Core 0 (A) 2475 MHz (CH25) 99% Bandwidth

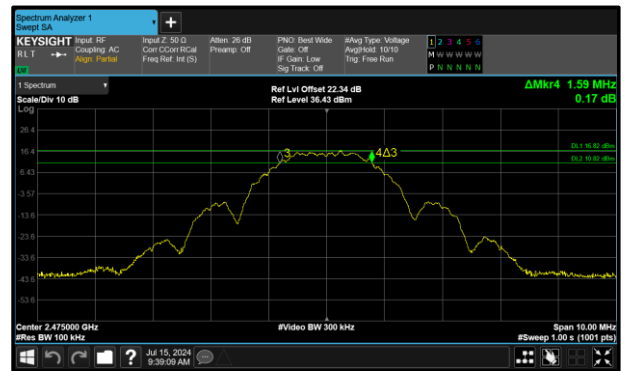

Figure 22 - Core 0 (A) 2475 MHz (CH25) 6 dB Bandwidth



Test Configuration			
Frequency Range:	2400-2483.5 MHz	Band:	2.4 GHz
Limit Clause(s):	15.247 (a)(2) RSS-247 5.2 a)	Test Method(s):	C63.10 6.9.3 C63.10 11.8.1
Additional Reference(s):	-		

DUT Configuration			
Mode:	Thread iPA	Duty Cycle (%):	-
Data Rate:	-	DCCF (dB):	-
Antenna Configuration:	SISO	Peak Antenna Gain (dBi):	-
Active Port(s):	B (Core 1)	Active Chain(s):	1

Test Frequency (MHz)	6 dB Bandwidth (MHz)				Limit (kHz)
	A	B	C	D	
2405	-	1.590	-	-	≥500.0
2440	-	1.590	-	-	≥500.0
2475	-	1.600	-	-	≥500.0

Table 19 - 6 dB Bandwidth Results

Test Frequency (MHz)	99% Bandwidth (MHz)				Limit (kHz)
	A	B	C	D	
2405	-	2.320	-	-	-
2440	-	2.320	-	-	-
2475	-	2.310	-	-	-

Table 20 - 99% Bandwidth Results

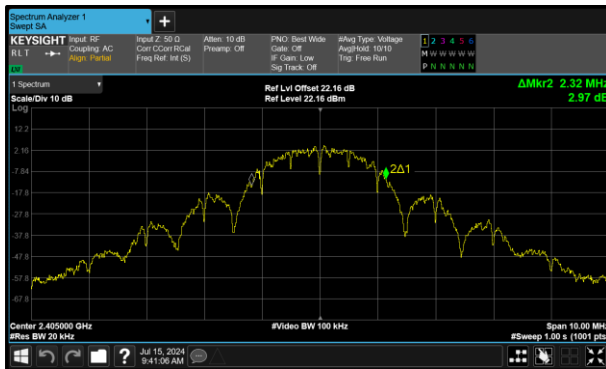

Figure 23 - Core 1 (B) 2405 MHz (CH11) 99% Bandwidth

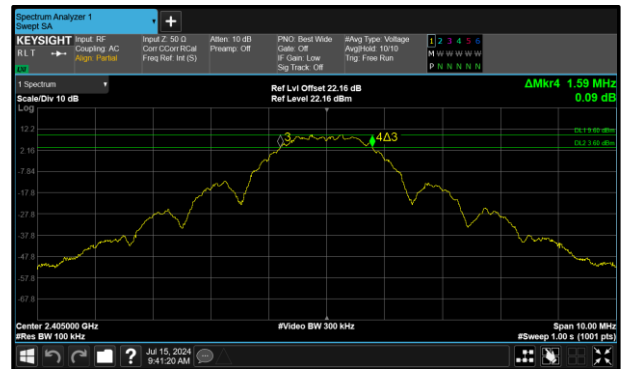

Figure 24 - Core 1 (B) 2405 MHz (CH11) 6 dB Bandwidth

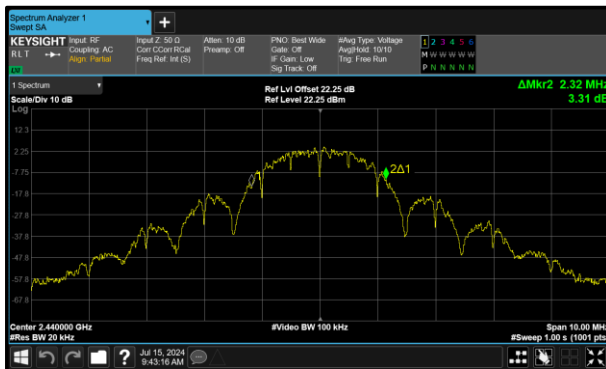

Figure 25 - Core 1 (B) 2440 MHz (CH18) 99% Bandwidth

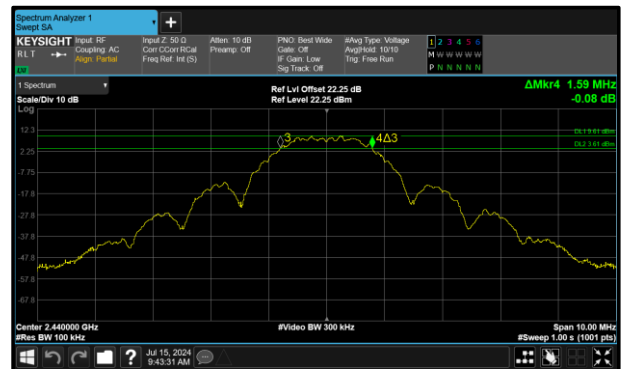

Figure 26 - Core 1 (B) 2440 MHz (CH18) 6 dB Bandwidth

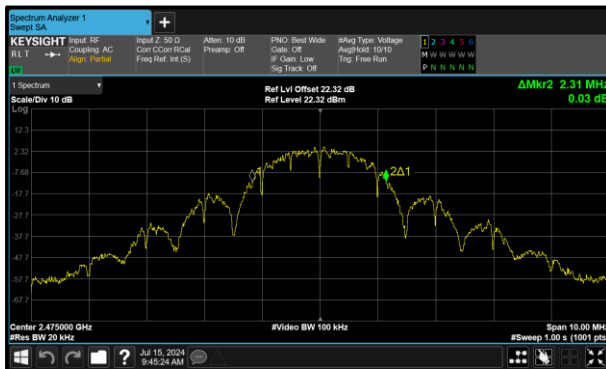

Figure 27 - Core 1 (B) 2475 MHz (CH25) 99% Bandwidth

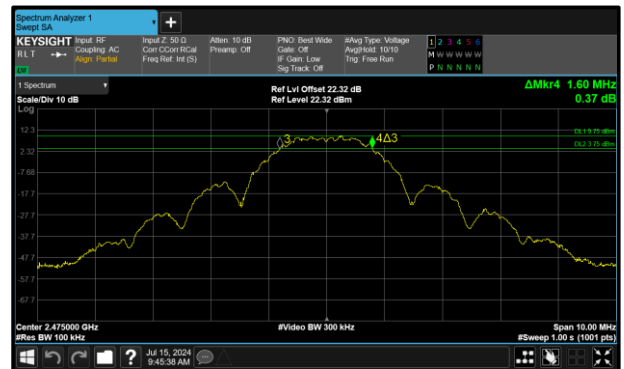

Figure 28 - Core 1 (B) 2475 MHz (CH25) 6 dB Bandwidth



Test Configuration			
Frequency Range:	2400-2483.5 MHz	Band:	2.4 GHz
Limit Clause(s):	15.247 (a)(2) RSS-247 5.2 a)	Test Method(s):	C63.10 6.9.3 C63.10 11.8.1
Additional Reference(s):	-		

DUT Configuration			
Mode:	Thread ePA	Duty Cycle (%):	-
Data Rate:	-	DCCF (dB):	-
Antenna Configuration:	SISO	Peak Antenna Gain (dBi):	-
Active Port(s):	B (Core 1)	Active Chain(s):	1

Test Frequency (MHz)	6 dB Bandwidth (MHz)				Limit (kHz)
	A	B	C	D	
2405	-	1.600	-	-	≥500.0
2440	-	1.600	-	-	≥500.0
2475	-	1.600	-	-	≥500.0

Table 21 - 6 dB Bandwidth Results

Test Frequency (MHz)	99% Bandwidth (MHz)				Limit (kHz)
	A	B	C	D	
2405	-	2.350	-	-	-
2440	-	2.350	-	-	-
2475	-	2.350	-	-	-

Table 22 - 99% Bandwidth Results

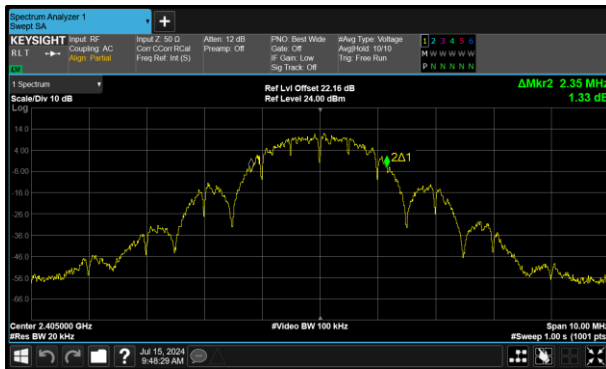

Figure 29 - Core 1 (B) 2405 MHz (CH11) 99% Bandwidth

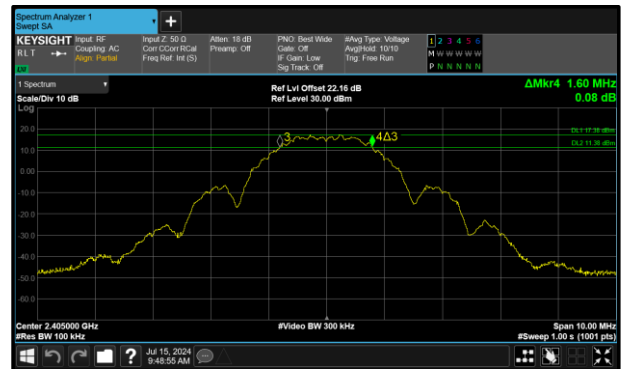

Figure 30 - Core 1 (B) 2405 MHz (CH11) 6 dB Bandwidth

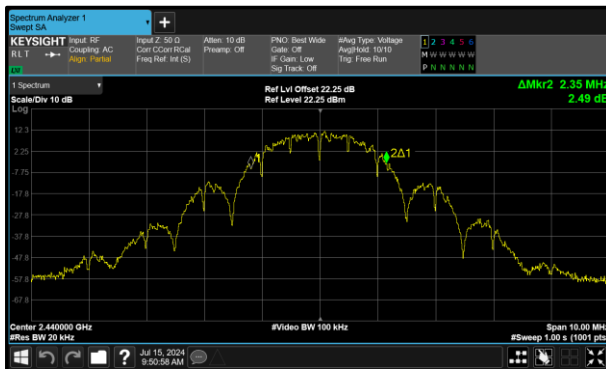

Figure 31 - Core 1 (B) 2440 MHz (CH18) 99% Bandwidth

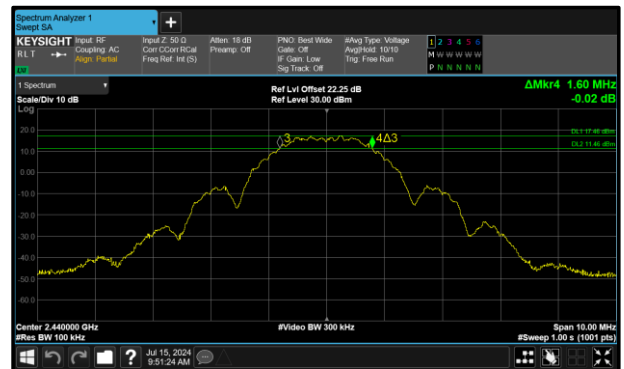

Figure 32 - Core 1 (B) 2440 MHz (CH18) 6 dB Bandwidth

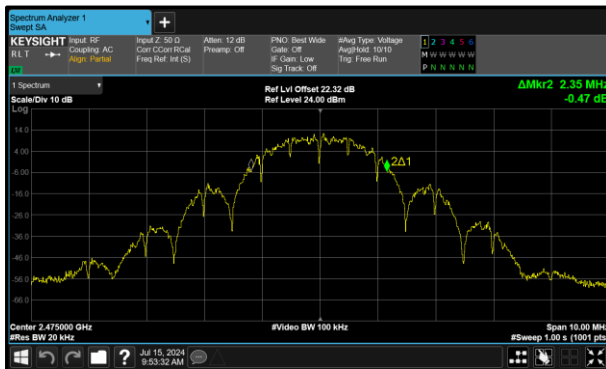

Figure 33 - Core 1 (B) 2475 MHz (CH25) 99% Bandwidth

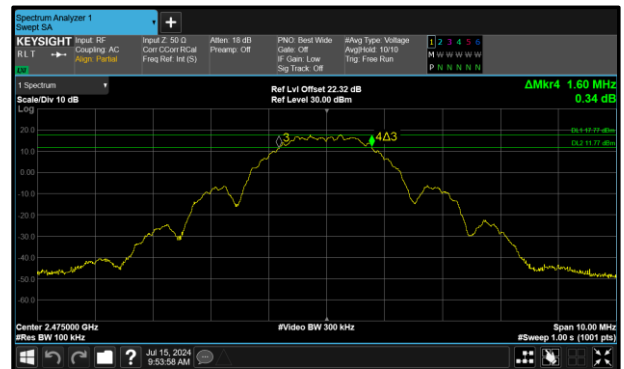

Figure 34 - Core 1 (B) 2475 MHz (CH25) 6 dB Bandwidth



Test Configuration			
Frequency Range:	2400-2483.5 MHz	Band:	2.4 GHz
Limit Clause(s):	15.247 (a)(2) RSS-247 5.2 a)	Test Method(s):	C63.10 6.9.3 C63.10 11.8.1
Additional Reference(s):	-		

DUT Configuration			
Mode:	Thread iPA	Duty Cycle (%):	-
Data Rate:	-	DCCF (dB):	-
Antenna Configuration:	SISO	Peak Antenna Gain (dBi):	-
Active Port(s):	C (Core 2)	Active Chain(s):	2

Test Frequency (MHz)	6 dB Bandwidth (MHz)				Limit (kHz)
	A	B	C	D	
2405	-	-	1.590	-	≥500.0
2440	-	-	1.590	-	≥500.0
2475	-	-	1.600	-	≥500.0

Table 23 - 6 dB Bandwidth Results

Test Frequency (MHz)	99% Bandwidth (MHz)				Limit (kHz)
	A	B	C	D	
2405	-	-	2.330	-	-
2440	-	-	2.330	-	-
2475	-	-	2.330	-	-

Table 24 - 99% Bandwidth Results

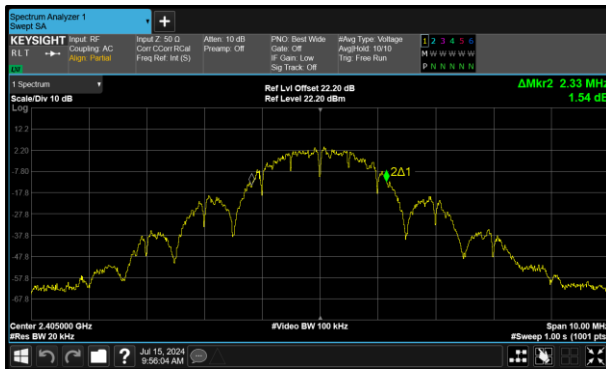

Figure 35 - Core 2 (C) 2405 MHz (CH11) 99% Bandwidth

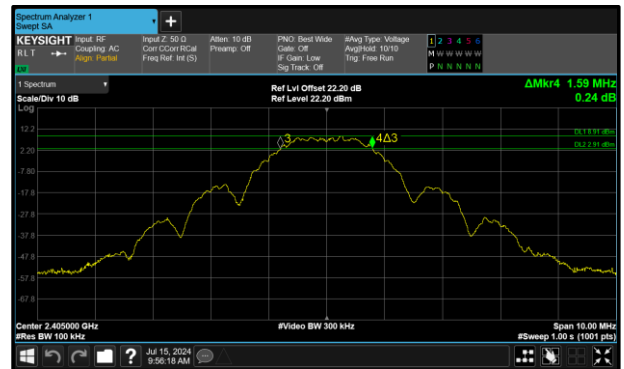

Figure 36 - Core 2 (C) 2405 MHz (CH11) 6 dB Bandwidth

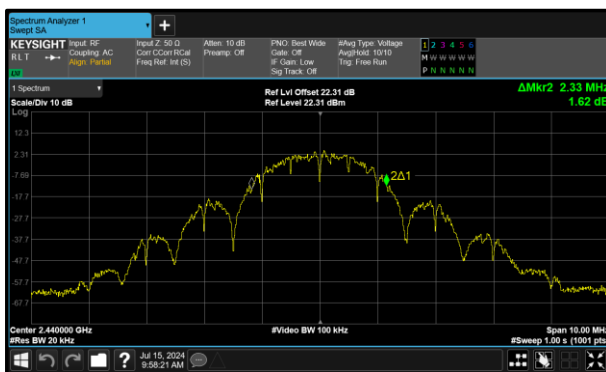

Figure 37 - Core 2 (C) 2440 MHz (CH18) 99% Bandwidth

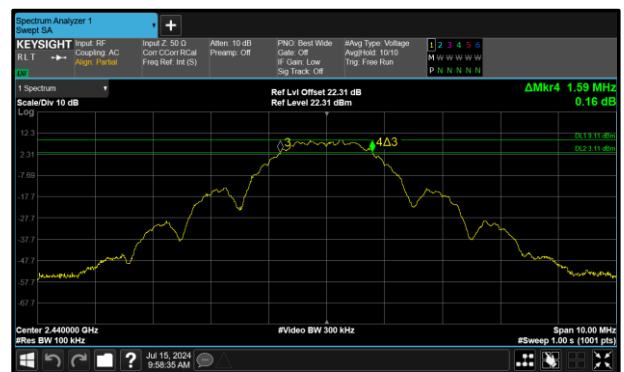

Figure 38 - Core 2 (C) 2440 MHz (CH18) 6 dB Bandwidth

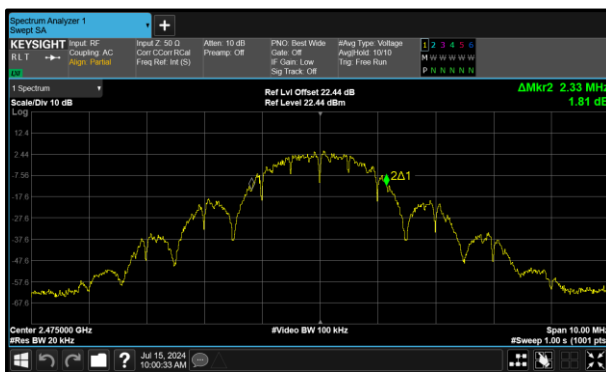

Figure 39 - Core 2 (C) 2475 MHz (CH25) 99% Bandwidth

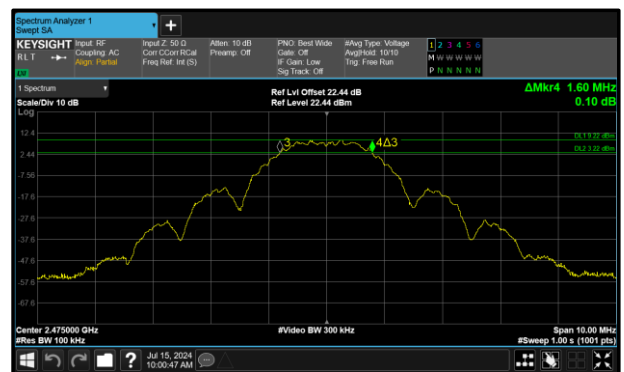

Figure 40 - Core 2 (C) 2475 MHz (CH25) 6 dB Bandwidth

FCC 47 CFR Part 15, Limit Clause 15.247(a)(2) and ISED RSS-247, Clause 5.2(a)

The minimum 6 dB Bandwidth shall be at least 500 kHz.



2.2.7 Test Location and Test Equipment Used

This test was carried out in RF Laboratory 14.

Instrument	Manufacturer	Type No.	TE No.	Calibration Period (months)	Calibration Expiry Date
Hygrometer	Rotronic	I-1000	3068	12	07-Nov-2024
Digital Multimeter	Fluke	115	6145	12	06-Jun-2025
MXA Signal Analyser	Keysight Technologies	N9020B	6417	24	26-Feb-2025
Signal Conditioning Unit	TUV SUD	SPECTRUM_SCU001	6518	12	16-Feb-2025
SCU Cable Assembly	TUV SUD	SPECTRUM_SCU_CA	6529	12	16-Feb-2025
SCU Cable Assembly	TUV SUD	SPECTRUM_SCU_CA	6530	12	16-Feb-2025
SCU Cable Assembly	TUV SUD	SPECTRUM_SCU_CA	6531	12	16-Feb-2025
AC Programmable Power Supply	iTech	IT7324	6662	-	O/P Mon

Table 25

O/P Mon - Output Monitored using calibrated equipment



2.3 Maximum Conducted Output Power

2.3.1 Specification Reference

FCC 47 CFR Part 15C, Clause 15.247 (b)
ISED RSS-247, Clause 5.4
ISED RSS-GEN, Clause 6.12

2.3.2 Equipment Under Test and Modification State

A3112, S/N: DQH6Q99MH - Modification State 0

2.3.3 Date of Test

15-July-2024

2.3.4 Test Method

The test was performed in accordance with ANSI C63.10 clause 11.9.2.3.2 using a power meter.

2.3.5 Environmental Conditions

Ambient Temperature	20.3 °C
Relative Humidity	55.5 %



2.3.6 Test Results

Thread

Test Configuration			
Frequency Range:	2400-2483.5 MHz	Band:	2.4 GHz
Limit Clause(s):	15.247 (b)(3) RSS-247 5.4 d)	Test Method(s):	C63.10 11.9.2.3.2
Additional Reference(s):	-		

DUT Configuration			
Mode:	Thread iPA	Duty Cycle (%):	88.9
Data Rate:	-	DCCF (dB):	-
Antenna Configuration:	SISO	Peak Antenna Gain (dBi):	4.60
Active Port(s):	A (Core 0)	Active Chain(s):	0

Test Frequency (MHz)	Maximum Conducted Output Power (dBm)					Limit (dBm)	Margin (dB)
	A	B	C	D	Σ		
2405	12.97	-	-	-	12.97	30.00	-17.03
2440	12.60	-	-	-	12.60	30.00	-17.40
2475	12.53	-	-	-	12.53	30.00	-17.47

Table 26 - FCC Maximum Conducted (average) Output Power Results

Test Frequency (MHz)	Maximum Conducted Output Power (dBm)					Limit (dBm)	Margin (dB)	EIRP (dBm)	EIRP Limit (dBm)	EIRP Margin (dB)
	A	B	C	D	Σ					
2405	12.97	-	-	-	12.97	30.00	-17.03	17.57	36.00	-18.43
2440	12.60	-	-	-	12.60	30.00	-17.40	17.20	36.00	-18.80
2475	12.53	-	-	-	12.53	30.00	-17.47	17.13	36.00	-18.87

Table 27 - ISED Maximum Conducted (average) Output Power Results



Test ConfigurationR			
Frequency Range:	2400-2483.5 MHz	Band:	2.4 GHz
Limit Clause(s):	15.247 (b)(3) RSS-247 5.4 d)	Test Method(s):	C63.10 11.9.2.3.2
Additional Reference(s):	-		

DUT Configuration			
Mode:	Thread ePA	Duty Cycle (%):	88.9
Data Rate:	-	DCCF (dB):	-
Antenna Configuration:	SISO	Peak Antenna Gain (dBi):	4.60
Active Port(s):	A (Core 0)	Active Chain(s):	0

Test Frequency (MHz)	Maximum Conducted Output Power (dBm)					Limit (dBm)	Margin (dB)
	A	B	C	D	Σ		
2405	20.89	-	-	-	20.89	30.00	-9.11
2440	20.80	-	-	-	20.80	30.00	-9.20
2475	20.70	-	-	-	20.70	30.00	-9.30

Table 28 - FCC Maximum Conducted (average) Output Power Results

Test Frequency (MHz)	Maximum Conducted Output Power (dBm)					Limit (dBm)	Margin (dB)	EIRP (dBm)	EIRP Limit (dBm)	EIRP Margin (dB)
	A	B	C	D	Σ					
2405	20.89	-	-	-	20.89	30.00	-9.11	25.49	36.00	-10.51
2440	20.80	-	-	-	20.80	30.00	-9.20	25.40	36.00	-10.60
2475	20.70	-	-	-	20.70	30.00	-9.30	25.30	36.00	-10.70

Table 29 - ISED Maximum Conducted (average) Output Power Results



Test Configuration			
Frequency Range:	2400-2483.5 MHz	Band:	2.4 GHz
Limit Clause(s):	15.247 (b)(3) RSS-247 5.4 d)	Test Method(s):	C63.10 11.9.2.3.2
Additional Reference(s):	-		

DUT Configuration			
Mode:	Thread iPA	Duty Cycle (%):	88.9
Data Rate:	-	DCCF (dB):	-
Antenna Configuration:	SISO	Peak Antenna Gain (dBi):	4.20
Active Port(s):	B (Core 1)	Active Chain(s):	1

Test Frequency (MHz)	Maximum Conducted Output Power (dBm)					Limit (dBm)	Margin (dB)
	A	B	C	D	Σ		
2405	-	12.56	-	-	12.56	30.00	-17.44
2440	-	12.60	-	-	12.60	30.00	-17.40
2475	-	12.75	-	-	12.75	30.00	-17.25

Table 30 - FCC Maximum Conducted (average) Output Power Results

Test Frequency (MHz)	Maximum Conducted Output Power (dBm)					Limit (dBm)	Margin (dB)	EIRP (dBm)	EIRP Limit (dBm)	EIRP Margin (dB)
	A	B	C	D	Σ					
2405	-	12.56	-	-	12.56	30.00	-17.44	16.76	36.00	-19.24
2440	-	12.60	-	-	12.60	30.00	-17.40	16.80	36.00	-19.20
2475	-	12.75	-	-	12.75	30.00	-17.25	16.95	36.00	-19.05

Table 31 - ISED Maximum Conducted (average) Output Power Results



Test Configuration			
Frequency Range:	2400-2483.5 MHz	Band:	2.4 GHz
Limit Clause(s):	15.247 (b)(3) RSS-247 5.4 d)	Test Method(s):	C63.10 11.9.2.3.2
Additional Reference(s):	-		

DUT Configuration			
Mode:	Thread ePA	Duty Cycle (%):	88.9
Data Rate:	-	DCCF (dB):	-
Antenna Configuration:	SISO	Peak Antenna Gain (dBi):	4.20
Active Port(s):	B (Core 1)	Active Chain(s):	1

Test Frequency (MHz)	Maximum Conducted Output Power (dBm)					Limit (dBm)	Margin (dB)
	A	B	C	D	Σ		
2405	-	20.51	-	-	20.51	30.00	-9.49
2440	-	20.82	-	-	20.82	30.00	-9.18
2475	-	20.80	-	-	20.80	30.00	-9.20

Table 32 - FCC Maximum Conducted (average) Output Power Results

Test Frequency (MHz)	Maximum Conducted Output Power (dBm)					Limit (dBm)	Margin (dB)	EIRP (dBm)	EIRP Limit (dBm)	EIRP Margin (dB)
	A	B	C	D	Σ					
2405	-	20.51	-	-	20.51	30.00	-9.49	24.71	36.00	-11.29
2440	-	20.82	-	-	20.82	30.00	-9.18	25.02	36.00	-10.98
2475	-	20.80	-	-	20.80	30.00	-9.20	25.00	36.00	-11.00

Table 33 - ISED Maximum Conducted (average) Output Power Results



Test Configuration			
Frequency Range:	2400-2483.5 MHz	Band:	2.4 GHz
Limit Clause(s):	15.247 (b)(3) RSS-247 5.4 d)	Test Method(s):	C63.10 11.9.2.3.2
Additional Reference(s):	-		

DUT Configuration			
Mode:	Thread iPA	Duty Cycle (%):	88.9
Data Rate:	-	DCCF (dB):	-
Antenna Configuration:	SISO	Peak Antenna Gain (dBi):	4.30
Active Port(s):	C (Core 2)	Active Chain(s):	2

Test Frequency (MHz)	Maximum Conducted Output Power (dBm)					Limit (dBm)	Margin (dB)
	A	B	C	D	Σ		
2405	-	-	12.01	-	12.01	30.00	-17.99
2440	-	-	12.25	-	12.25	30.00	-17.75
2475	-	-	12.20	-	12.20	30.00	-17.80

Table 34 - FCC Maximum Conducted (average) Output Power Results

Test Frequency (MHz)	Maximum Conducted Output Power (dBm)					Limit (dBm)	Margin (dB)	EIRP (dBm)	EIRP Limit (dBm)	EIRP Margin (dB)
	A	B	C	D	Σ					
2405	-	-	12.01	-	12.01	30.00	-17.99	16.31	36.00	-19.69
2440	-	-	12.25	-	12.25	30.00	-17.75	16.55	36.00	-19.45
2475	-	-	12.20	-	12.20	30.00	-17.80	16.50	36.00	-19.50

Table 35 - ISED Maximum Conducted (average) Output Power Results

FCC 47 CFR Part 15, Limit Clause 15.247 (b)(3)

For systems using digital modulation in the 902–928 MHz, 2400–2483.5 MHz, and 5725–5850 MHz bands: 1 Watt.

ISED RSS-247, Limit Clause 5.4 (d)

For DTSs employing digital modulation techniques operating in the bands 902-928 MHz and 2400-2483.5 MHz, the maximum peak conducted output power shall not exceed 1 W. The e.i.r.p. shall not exceed 4 W, except as provided in section 5.4(e) of the specification.



2.3.7 Test Location and Test Equipment Used

This test was carried out in RF Laboratory 14.

Instrument	Manufacturer	Type No.	TE No.	Calibration Period (months)	Calibration Expiry Date
Hygrometer	Rotronic	I-1000	3068	12	07-Nov-2024
Digital Multimeter	Fluke	115	6145	12	06-Jun-2025
Signal Conditioning Unit	TUV SUD	SPECTRUM_SCU001	6518	12	16-Feb-2025
SCU Cable Assembly	TUV SUD	SPECTRUM_SCU_CA	6529	12	16-Feb-2025
SCU Cable Assembly	TUV SUD	SPECTRUM_SCU_CA	6530	12	16-Feb-2025
SCU Cable Assembly	TUV SUD	SPECTRUM_SCU_CA	6531	12	16-Feb-2025
USB Wideband Power Sensor	Boonton	RTP5008	6587	12	13-Feb-2025
USB Wideband Power Sensor	Boonton	RTP5008	6588	12	13-Feb-2025
USB Wideband Power Sensor	Boonton	RTP5008	6589	12	13-Feb-2025
AC Programmable Power Supply	iTech	IT7324	6662	-	O/P Mon

Table 36

O/P Mon - Output Monitored using calibrated equipment



2.4 Authorised Band Edges

2.4.1 Specification Reference

FCC 47 CFR Part 15C, Clause 15.247 (d)
ISED RSS-247, Clause 5.5

2.4.2 Equipment Under Test and Modification State

A3112, S/N: K67X45QH3Q - Modification State 0

2.4.3 Date of Test

10-June-2024 to 14-June-2024

2.4.4 Test Method

The test was performed in accordance with ANSI C63.10, clause 6.10.4.

2.4.5 Environmental Conditions

Ambient Temperature	23.0 - 23.1 °C
Relative Humidity	40.8 - 42.7 %



2.4.6 Test Results

Thread

iPA - Core 0 (SISO)

Mode	TX Frequency (MHz)	Band Edge Frequency (MHz)	Level (dBc)
Thread	2405	2400	-65.28

Table 37 - iPA, Core 0, SISO Authorised Band Edge Results

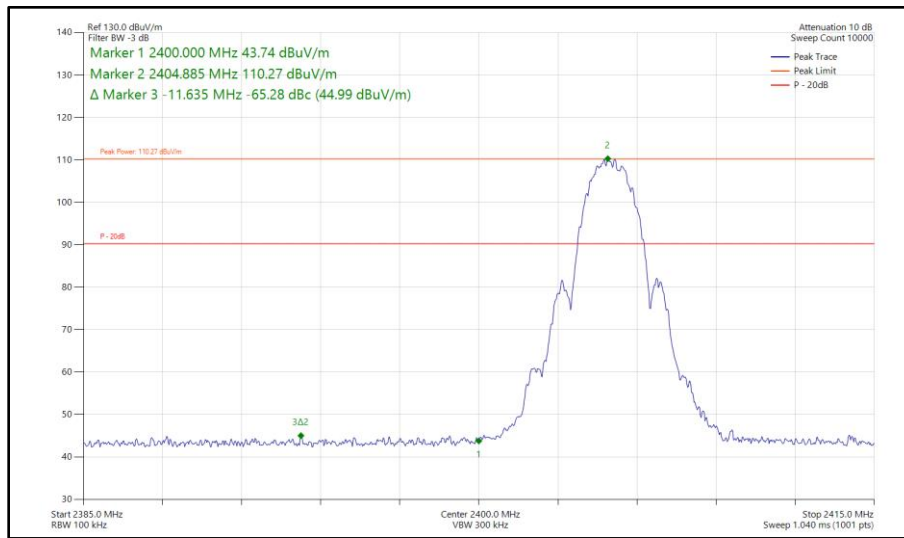

**Figure 41 - Thread, iPA, SISO, Core 0 - 2405 MHz
 Band Edge Frequency 2400 MHz**



iPA - Core 1 (SISO)

Mode	TX Frequency (MHz)	Band Edge Frequency (MHz)	Level (dBc)
Thread	2405	2400	-63.21

Table 38 - iPA, Core 1, SISO Authorised Band Edge Results

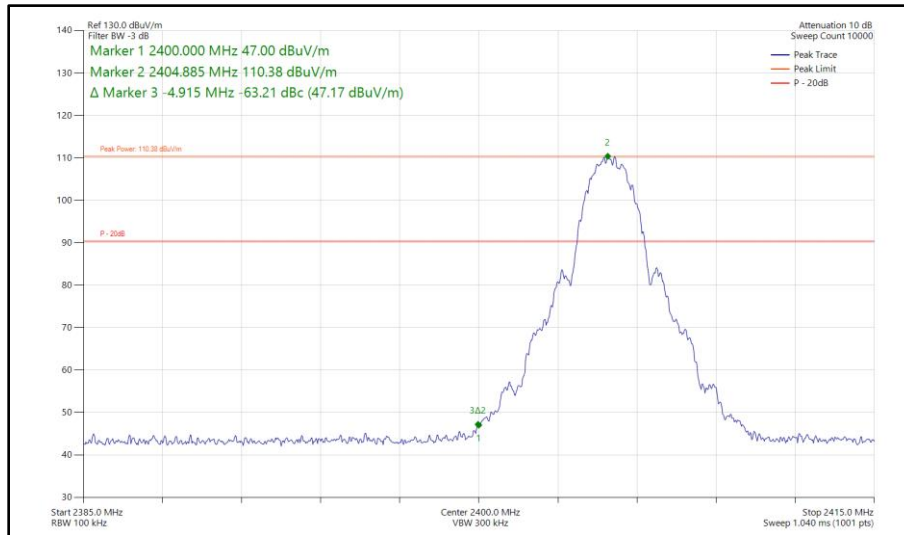

**Figure 42 - Thread, iPA, SISO, Core 1 - 2405 MHz
 Band Edge Frequency 2400 MHz**



iPA - Core 2 (SISO)

Mode	TX Frequency (MHz)	Band Edge Frequency (MHz)	Level (dBc)
Thread	2405	2400	-63.20

Table 39 - iPA, Core 2, SISO Authorised Band Edge Results

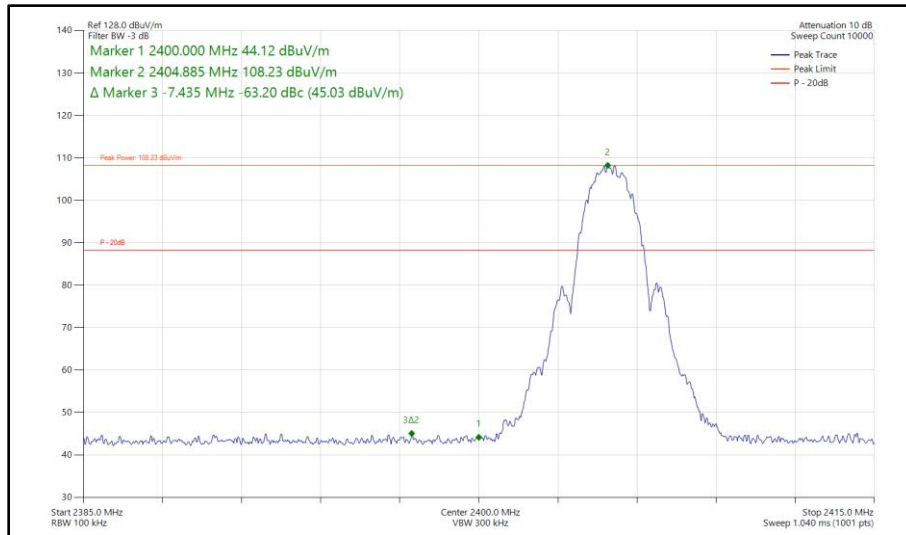

**Figure 43 - Thread, iPA, SISO, Core 2 - 2405 MHz
 Band Edge Frequency 2400 MHz**



ePA - Core 0 (SISO)

Mode	TX Frequency (MHz)	Band Edge Frequency (MHz)	Level (dBc)
Thread	2405	2400	-67.49

Table 40 - ePA, Core 0, SISO Authorised Band Edge Results

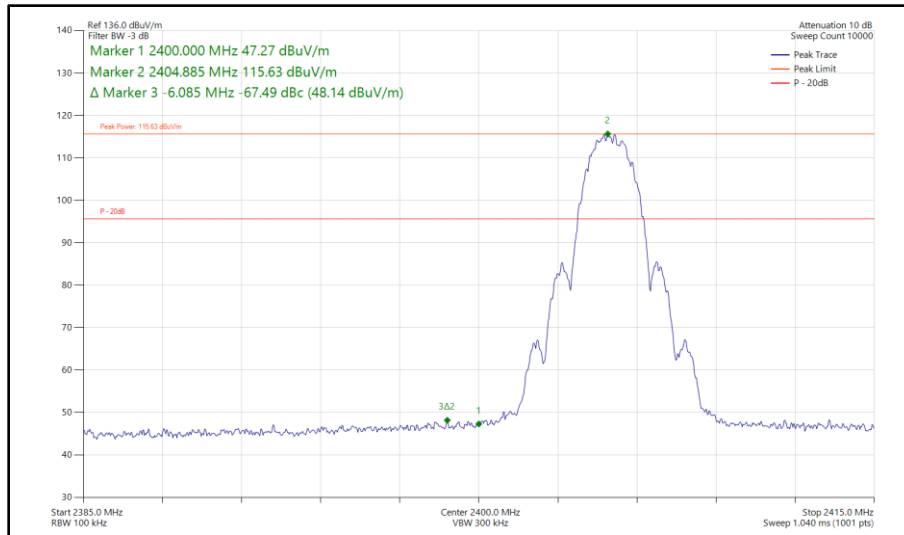

**Figure 44 - Thread, ePA, SISO, Core 0 - 2405 MHz
 Band Edge Frequency 2400 MHz**



ePA - Core 1 (SISO)

Mode	TX Frequency (MHz)	Band Edge Frequency (MHz)	Level (dBc)
Thread	2405	2400	-66.68

Table 41 - ePA, Core 1, SISO Authorised Band Edge Results

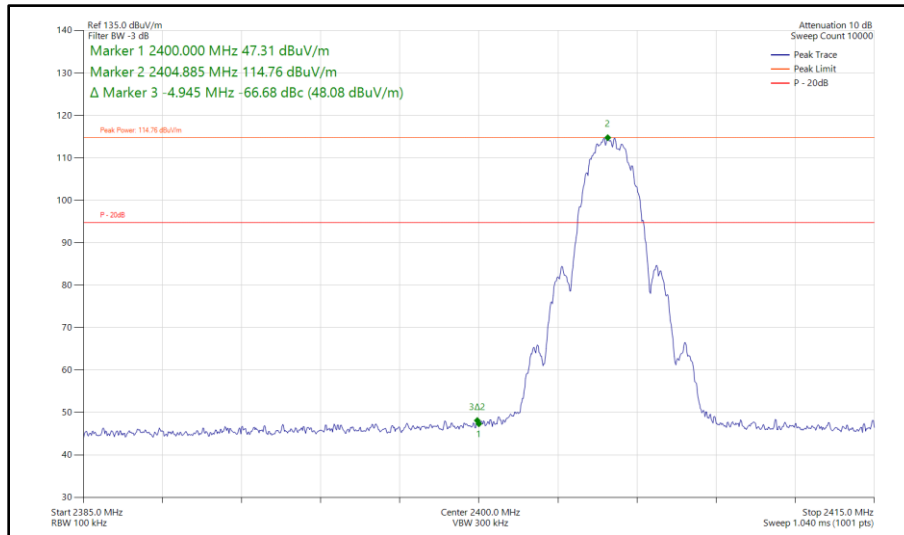

**Figure 45 - Thread, ePA, SISO, Core 1 - 2405 MHz
 Band Edge Frequency 2400 MHz**

FCC 47 CFR Part 15, Limit Clause 15.247 (d)

20 dB below the fundamental measured in a 100 kHz bandwidth using a peak detector. If the transmitter complies with the conducted power limits, based on the use of RMS averaging over a time interval, the attenuation required shall be 30 dB below the fundamental instead of 20 dB.

ISED RSS-247, Limit Clause 5.5

In any 100 kHz bandwidth outside the frequency band in which the spread spectrum or digitally modulated device is operating, the RF power that is produced shall be at least 20 dB below that in the 100 kHz bandwidth within the band that contains the highest level of the desired power, based on either an RF conducted or a radiated measurement, provided that the transmitter demonstrates compliance with the peak conducted power limits. If the transmitter complies with the conducted power limits based on the use of root-mean-square averaging over a time interval, as permitted under Section 5.4(4), the attenuation required shall be 30 dB instead of 20 dB. Attenuation below the general field strength limits specified in RSS-Gen is not required.



2.4.7 Test Location and Test Equipment Used

This test was carried out in RF Chamber 15

Instrument	Manufacturer	Type No.	TE No.	Calibration Period (months)	Calibration Expiry Date
Emissions Software	TUV SUD	EmX V3.2.0	5125	-	Software
EMI Test Receiver	Rohde & Schwarz	ESW44	5911	12	11-Sep-2024
1500W (300V 12A) AC Power Supply	iTech	IT7324	5955	-	O/P Mon
5m Semi-Anechoic Chamber (Dual-Axis), Chamber 15	Albatross Projects	RF Chamber 15	5963	36	28-Apr-2025
Compact Antenna Mast	Maturo Gmbh	CAM4.0-P	5964	-	TU
Mast & Turntable Controller	Maturo Gmbh	FCU3.0	5966	-	TU
Tilt Antenna Mast	Maturo Gmbh	BAM4.5-P	5967	-	TU
Turntable	Maturo Gmbh	TT1.5SI	5968	-	TU
Cable (SMA to SMA 1m)	Junkosha	MWX221-01000AMSAMS/A	5997	12	14-Sep-2024
Cable (N to N 1m)	Junkosha	MWX221-01000AMSAMS/B	6009	12	20-May-2025
Horn Antenna (1-10 GHz)	Schwarzbeck	BBHA9120B	6140	12	05-May-2025
Horn Antenna (1-10 GHz)	Schwarzbeck	BBHA9120B	6142	12	05-May-2025
Digital Multimeter	Fluke	115	6147	12	06-Jun-2025
SAC Switch Unit	TUV SUD	TUV_SSU_001	6191	12	18-Dec-2024
Humidity and Temperature Meter	R.S Components	1364	6486	12	04-Jun-2025
1m Cable	Junkosha	MWX241-01000AMSAMS/B	6740	12	01-Feb-2025
6.5m Cable	Junkosha	MWX221-06500AMSAMS/B	6744	12	01-Feb-2025

Table 42

TU - Traceability Unscheduled

O/P Mon - Output Monitored using calibrated equipment



2.5 Spurious Radiated Emissions

2.5.1 Specification Reference

FCC 47 CFR Part 15C, Clause 15.209 and 15.247 (d)
ISED RSS-247, Clause 3.3 and 5.5
ISED RSS-GEN, Clause 6.13 and 8.9

2.5.2 Equipment Under Test and Modification State

A3112, S/N: D2XW4JQFNK - Modification State 0
A3112, S/N: MNV254CLPF - Modification State 0

2.5.3 Date of Test

18-June-2024 to 24-June-2024

2.5.4 Test Method

This test was performed in accordance with ANSI C63.10, clause 6.3, 6.5 and 6.6.

Ports on the EUT were terminated with loads as described in ANSI C63.10 clause 6.2.3.

In the 30 MHz to 1 GHz range, pre-scans were only performed on the mid channel (2440 MHz).

The plots shown are the characterisation of the EUT. The limits on the plots represent the most stringent case for restricted bands, (74/54 dBuV/m) when compared to 20 dBc outside restricted bands. The limits shown have been used as a threshold to determine where further measurements are necessary. Where results are within 20 dB of the limits shown on the plots, further investigation was carried out and reported in results tables.

The following conversion can be applied to convert from dB μ V/m to μ V/m:
 $10^{(\text{Field Strength in dB}\mu\text{V/m}/20)}$.

To determine the emission characteristic of the EUT above 18 GHz, the test antenna was swept over all faces of the EUT whilst observing a spectral display. The frequency of any emissions of interest was noted for formal measurement at the correct measurement distance of 1m. This procedure was repeated for all relevant transmit operating channels.

Above 18 GHz, the measurement distance was reduced to 1 m. The limit line was increased by $20 \cdot \text{LOG}(3/1) = 9.54$ dB.

Where formal measurements have been necessary, the results have been presented in the emissions table.

2.5.5 Example Test Setup Diagram

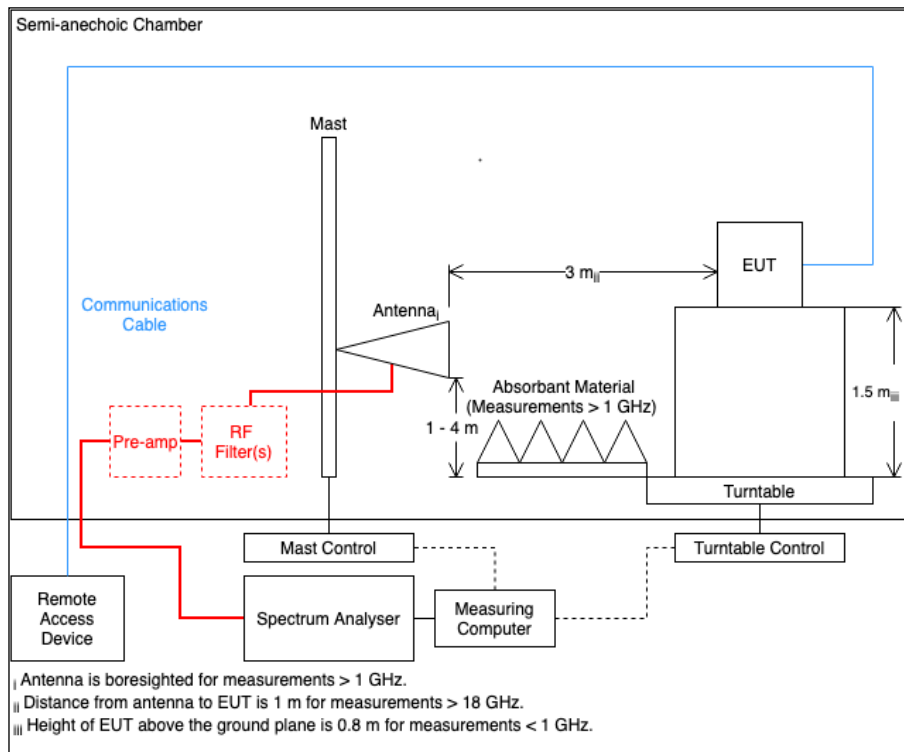

Figure 46

2.5.6 Environmental Conditions

Ambient Temperature 20.4 - 23.8 °C
Relative Humidity 38.3 - 48.6 %



2.5.7 Test Results

Thread

Frequency (MHz)	Level (dB μ V/m)	Limit (dB μ V/m)	Margin (dB)	Detector	Angle (°)	Height (cm)	Polarisation
2369.773	38.38	54.00	-15.62	RMS	354	343	Vertical
2483.519	34.24	54.00	-19.76	RMS	357	277	Vertical

Table 43 - 2405 MHz (CH11), Thread, ePA, Core 0, 1 GHz to 26 GHz

No other emissions found within 10 dB of the limit.

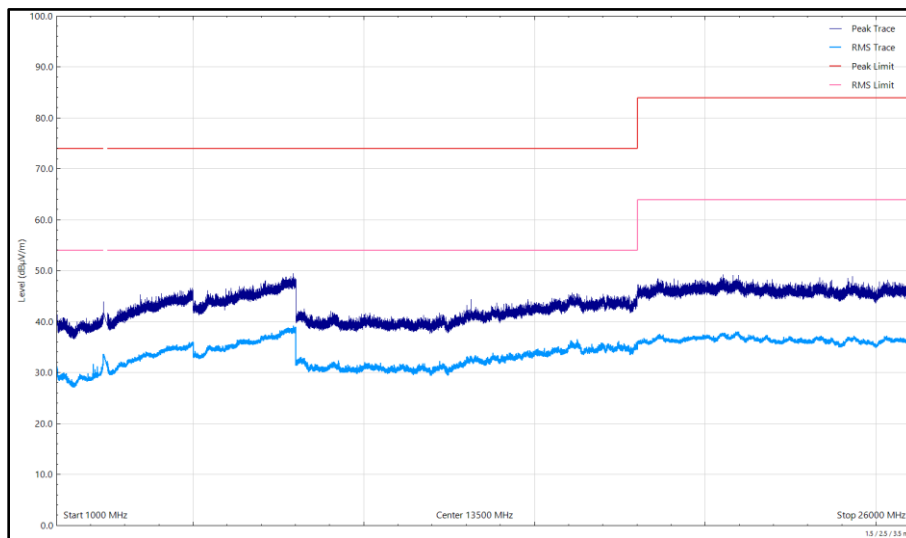

Figure 47 - 2405 MHz (CH11), Thread, ePA, Core 0, 1 GHz to 26 GHz, Horizontal

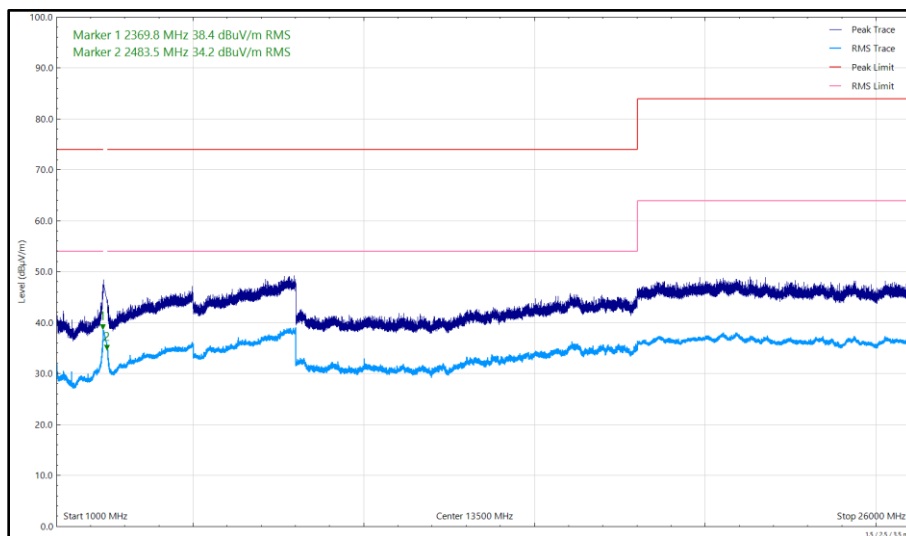

Figure 48 - 2405 MHz (CH11), Thread, ePA, Core 0, 1 GHz to 26 GHz, Vertical



Frequency (MHz)	Level (dBμV/m)	Limit (dBμV/m)	Margin (dB)	Detector	Angle (°)	Height (cm)	Polarisation
279.985	27.23	46.00	-18.77	Q-Peak	78	109	Horizontal
2389.935	37.40	54.00	-16.60	RMS	357	361	Vertical
2483.561	39.54	54.00	-14.46	RMS	13	334	Vertical

Table 44 - 2440 MHz (CH18), Thread, ePA, Core 0, 30 MHz to 26 GHz

No other emissions found within 10 dB of the limit.

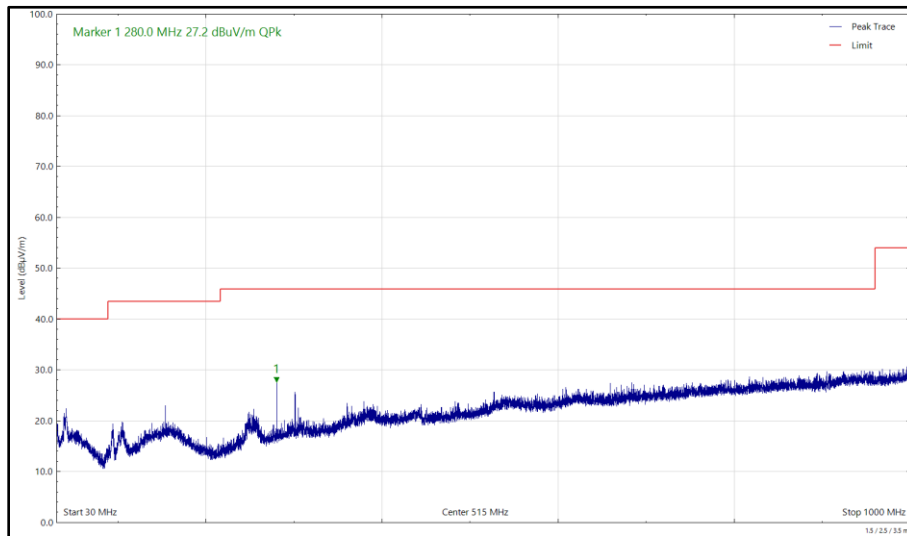

Figure 49 - 2440 MHz (CH18), Thread, ePA, Core 0, 30 MHz to 1 GHz, Horizontal (Peak)

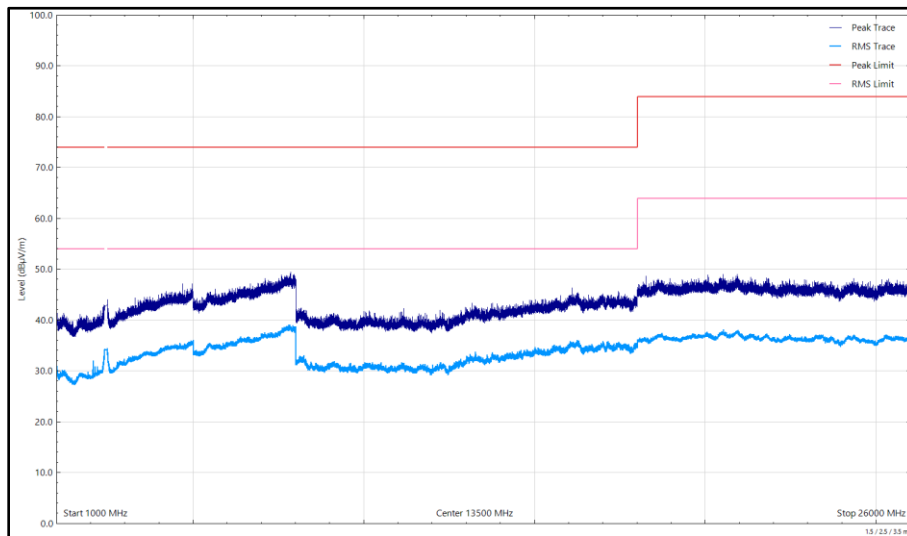

Figure 50 - 2440 MHz (CH18), Thread, ePA, Core 0, 1 GHz to 26 GHz, Horizontal

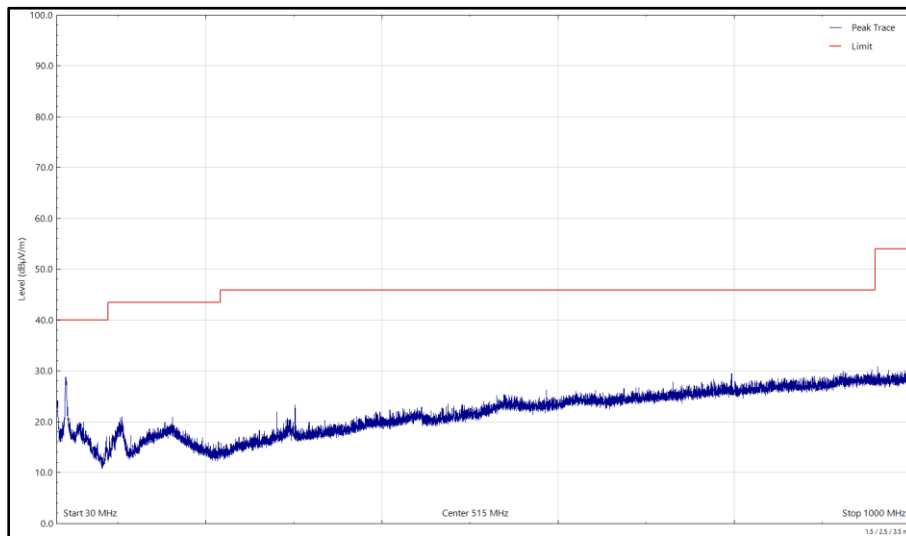

Figure 51 - 2440 MHz (CH18), Thread, ePA, Core 0, 30 MHz to 1 GHz, Vertical (Peak)

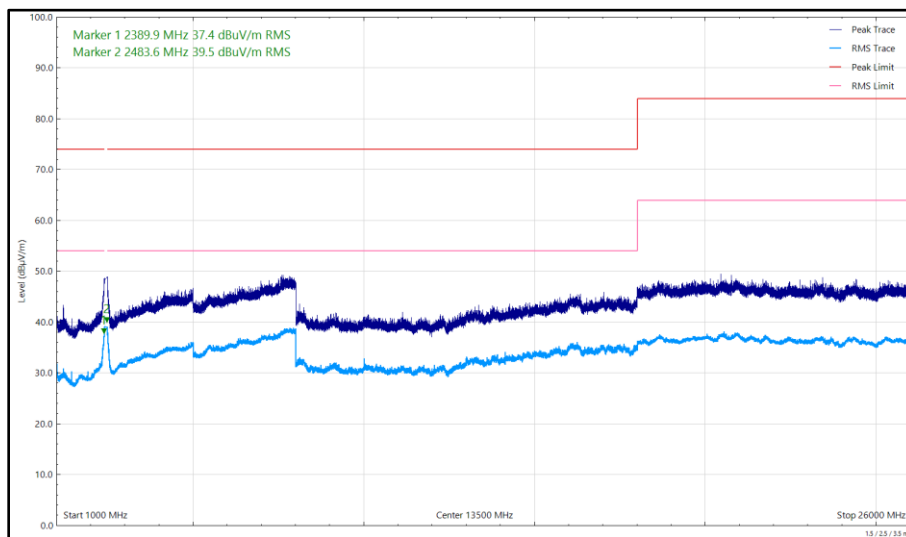

Figure 52 - 2440 MHz (CH18), Thread, ePA, Core 0, 1 GHz to 26 GHz, Vertical



Frequency (MHz)	Level (dBµV/m)	Limit (dBµV/m)	Margin (dB)	Detector	Angle (°)	Height (cm)	Polarisation
2389.994	35.56	54.00	-18.44	RMS	350	301	Vertical
2498.586	42.05	54.00	-11.95	RMS	0	343	Vertical
2498.598	38.20	54.00	-15.80	RMS	307	381	Horizontal
4207.044	33.35	54.00	-20.65	RMS	305	100	Vertical

Table 45 - 2475 MHz (CH25), Thread, ePA, Core 0, 1 GHz to 26 GHz

No other emissions found within 10 dB of the limit.

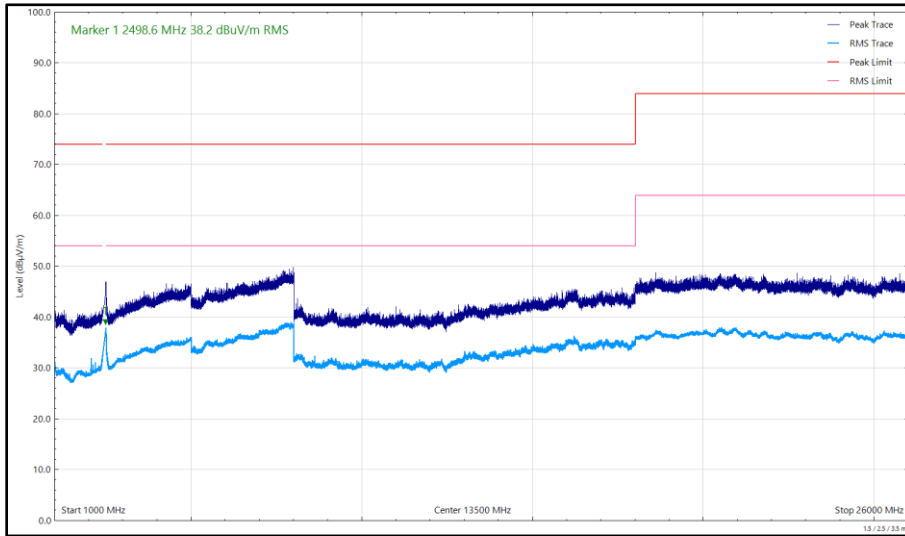

Figure 53 - 2475 MHz (CH25), Thread, ePA, Core 0, 1 GHz to 26 GHz, Horizontal

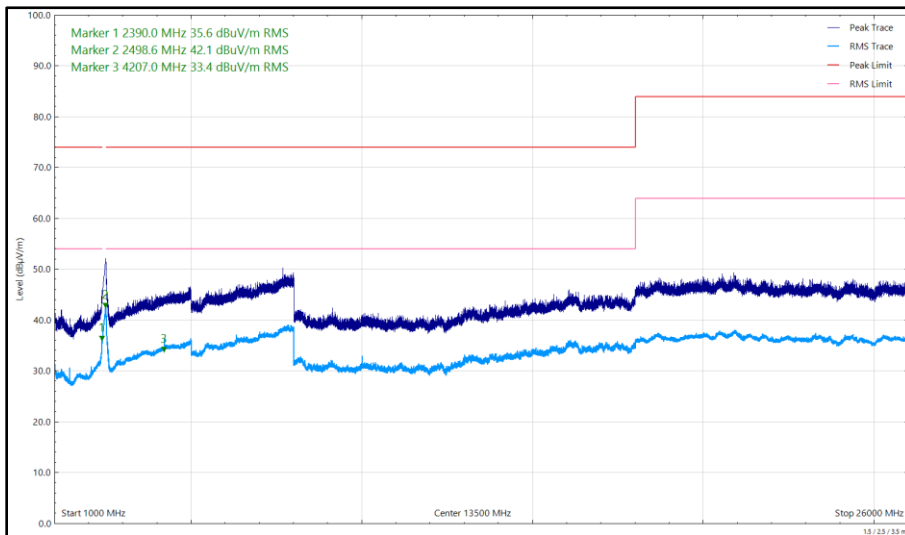

Figure 54 - 2475 MHz (CH25), Thread, ePA, Core 0, 1 GHz to 26 GHz, Vertical



Frequency (MHz)	Level (dB μ V/m)	Limit (dB μ V/m)	Margin (dB)	Detector	Angle (°)	Height (cm)	Polarisation
2369.936	36.15	54.00	-17.85	RMS	47	363	Vertical
4212.048	35.83	54.00	-18.17	RMS	335	359	Vertical

Table 46 - 2405 MHz (CH11), Thread, ePA, Core 1, 1 GHz to 26 GHz

No other emissions found within 10 dB of the limit.

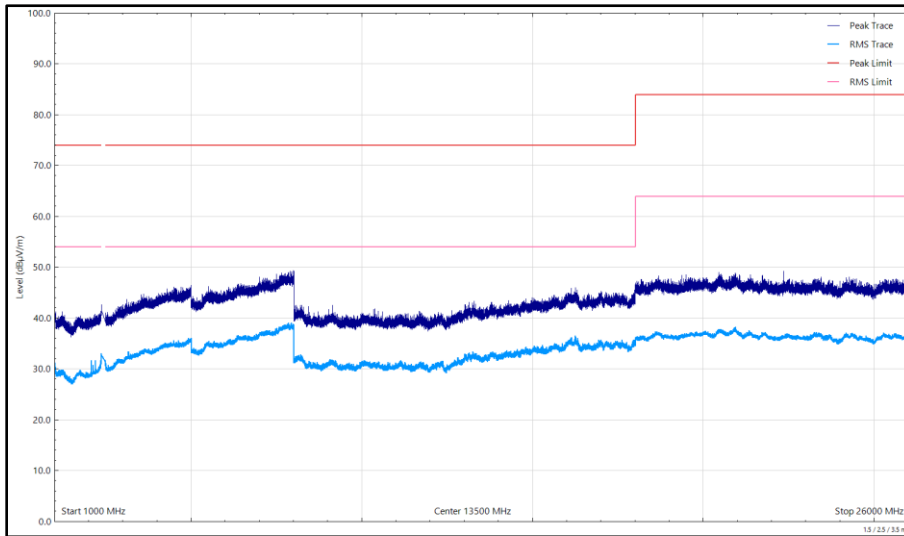

Figure 55 - 2405 MHz (CH11), Thread, ePA, Core 1, 1 GHz to 26 GHz, Horizontal

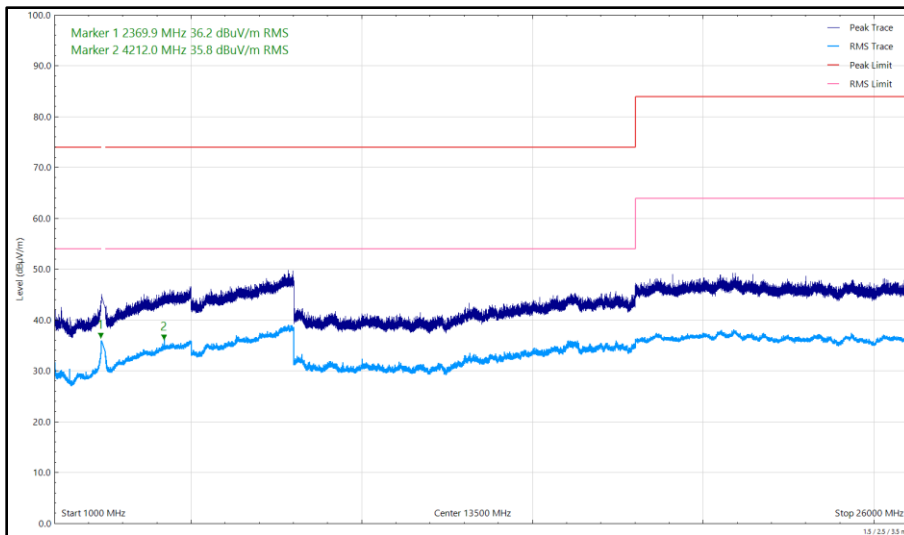

Figure 56 - 2405 MHz (CH11), Thread, ePA, Core 1, 1 GHz to 26 GHz, Vertical



Frequency (MHz)	Level (dBµV/m)	Limit (dBµV/m)	Margin (dB)	Detector	Angle (°)	Height (cm)	Polarisation
279.996	27.31	46.00	-18.69	Q-Peak	88	104	Horizontal
2389.777	36.31	54.00	-17.69	RMS	46	377	Vertical
2483.574	38.32	54.00	-15.68	RMS	42	397	Vertical
4199.520	33.29	54.00	-20.71	RMS	0	100	Vertical

Table 47 - 2440 MHz (CH18), Thread, ePA, Core 1, 30 MHz to 26 GHz

No other emissions found within 10 dB of the limit.

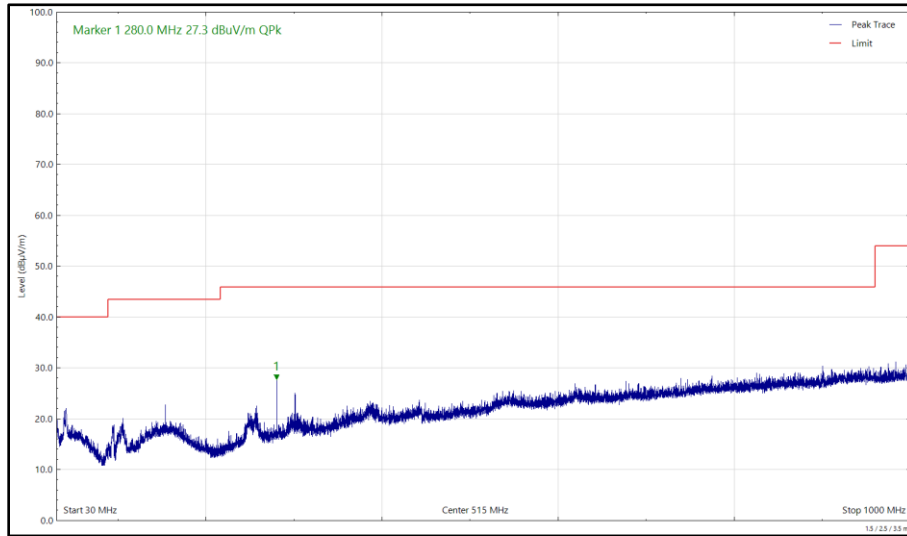

Figure 57 - 2440 MHz (CH18), Thread, ePA, Core 1, 30 MHz to 1 GHz, Horizontal (Peak)

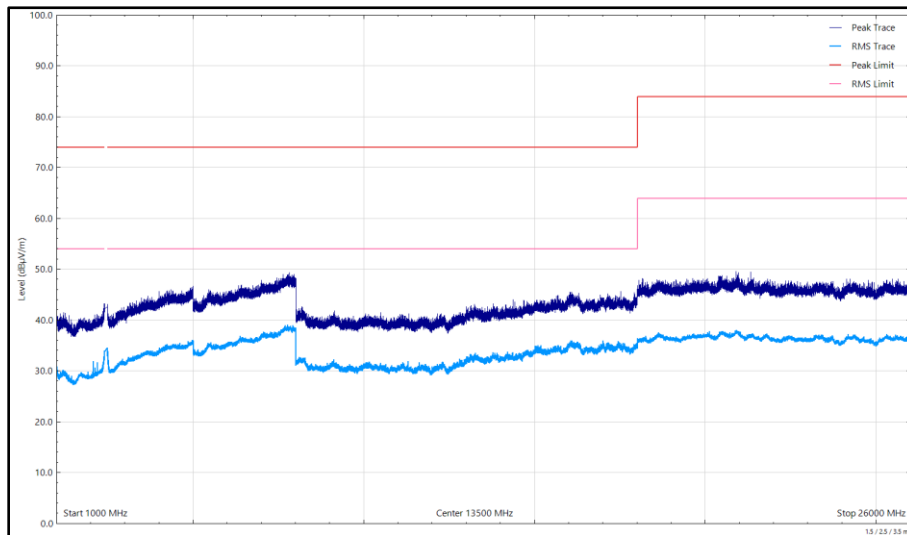

Figure 58 - 2440 MHz (CH18), Thread, ePA, Core 1, 1 GHz to 26 GHz, Horizontal

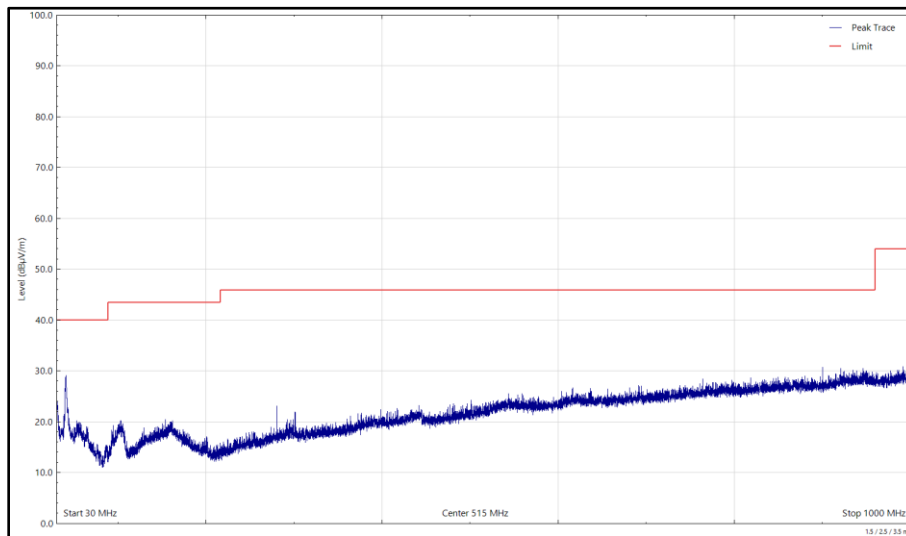

Figure 59 - 2440 MHz (CH18), Thread, ePA, Core 1, 30 MHz to 1 GHz, Vertical (Peak)

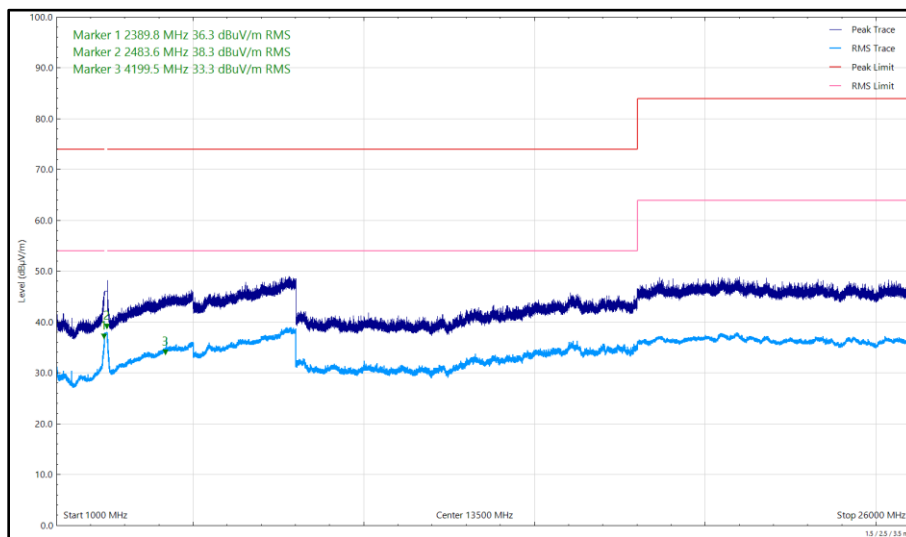

Figure 60 - 2440 MHz (CH18), Thread, ePA, Core 1, 1 GHz to 26 GHz, Vertical



Frequency (MHz)	Level (dBµV/m)	Limit (dBµV/m)	Margin (dB)	Detector	Angle (°)	Height (cm)	Polarisation
2498.648	40.87	54.00	-13.13	RMS	52	387	Horizontal
2498.746	44.16	54.00	-9.84	RMS	46	382	Vertical
2498.805	56.55	74.00	-17.45	Peak	46	382	Vertical

Table 48 - 2475 MHz (CH25), Thread, ePA, Core 1, 1 GHz to 26 GHz

No other emissions found within 10 dB of the limit.

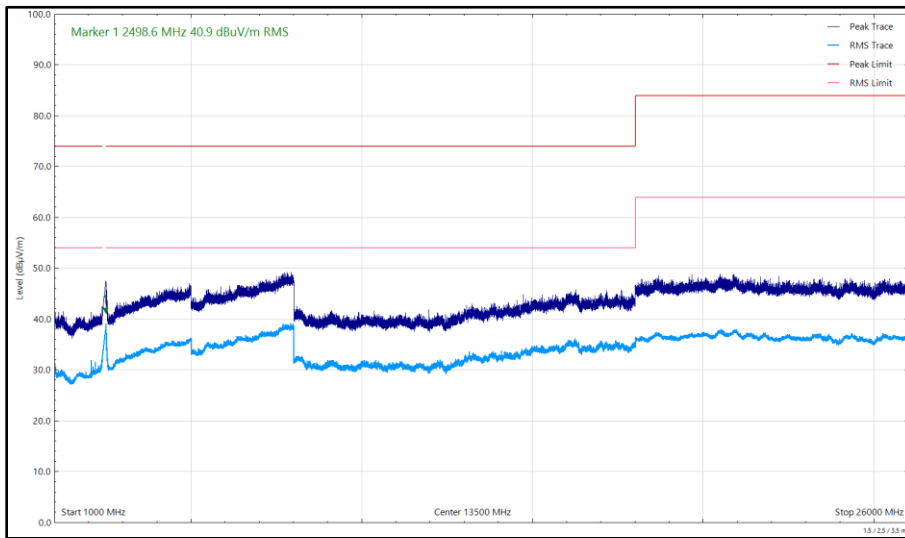

Figure 61 - 2475 MHz (CH25), Thread, ePA, Core 1, 1 GHz to 26 GHz, Horizontal

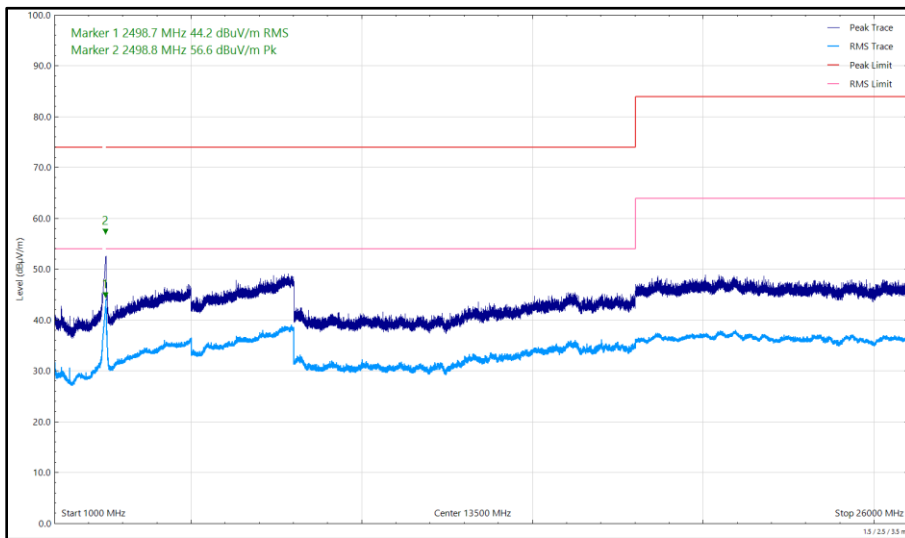

Figure 62 - 2475 MHz (CH25), Thread, ePA, Core 1, 1 GHz to 26 GHz, Vertical



Frequency (MHz)	Level (dBμV/m)	Limit (dBμV/m)	Margin (dB)	Detector	Angle (°)	Height (cm)	Polarisation
4810.832	34.60	54.00	-19.40	RMS	359	178	Vertical

Table 49 - 2405 MHz (CH11), Thread, iPA, Core 0, 1 GHz to 26 GHz

No other emissions found within 10 dB of the limit.

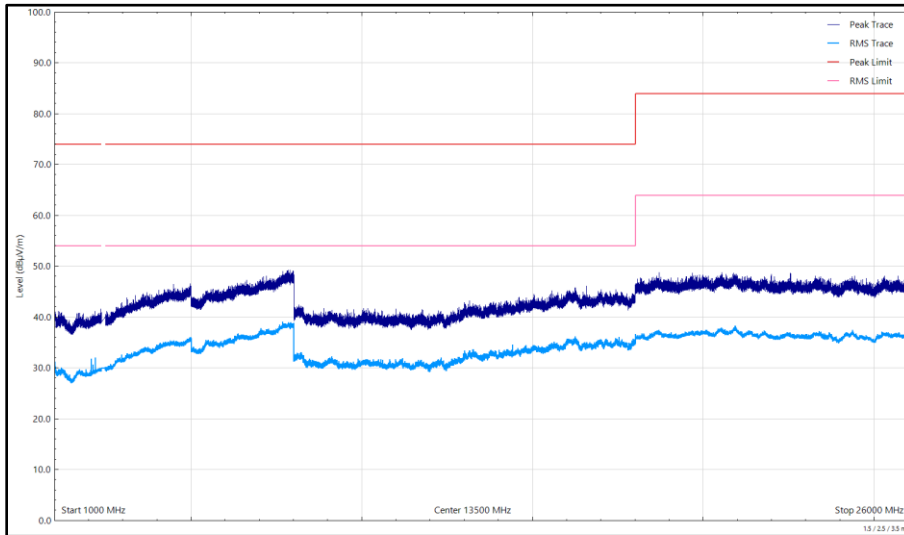

Figure 63 - 2405 MHz (CH11), Thread, iPA, Core 0, 1 GHz to 26 GHz, Horizontal

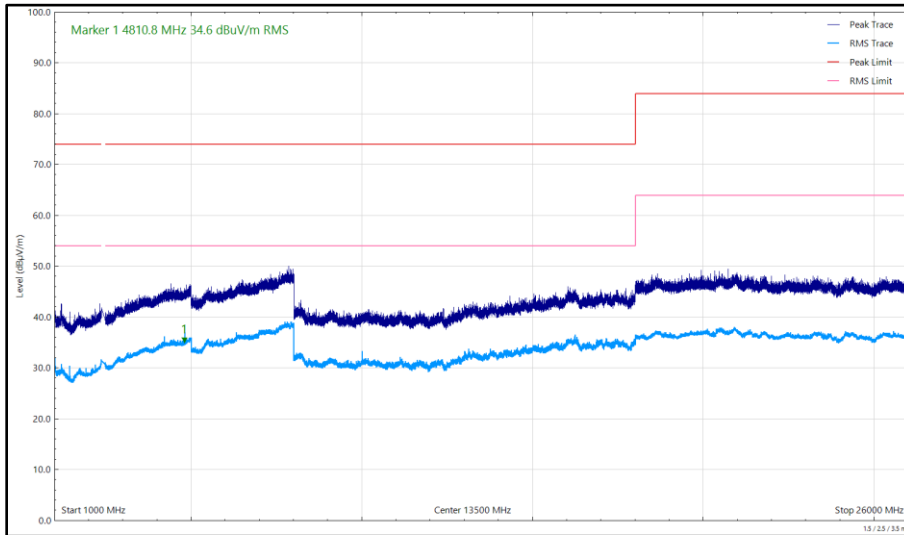

Figure 64 - 2405 MHz (CH11), Thread, iPA, Core 0, 1 GHz to 26 GHz, Vertical



Frequency (MHz)	Level (dBµV/m)	Limit (dBµV/m)	Margin (dB)	Detector	Angle (°)	Height (cm)	Polarisation
280.000	27.60	46.00	-18.40	Q-Peak	86	108	Horizontal
4212.153	33.84	54.00	-20.16	RMS	18	390	Vertical

Table 50 - 2440 MHz (CH18), Thread, iPA, Core 0, 30 MHz to 26 GHz

No other emissions found within 10 dB of the limit.

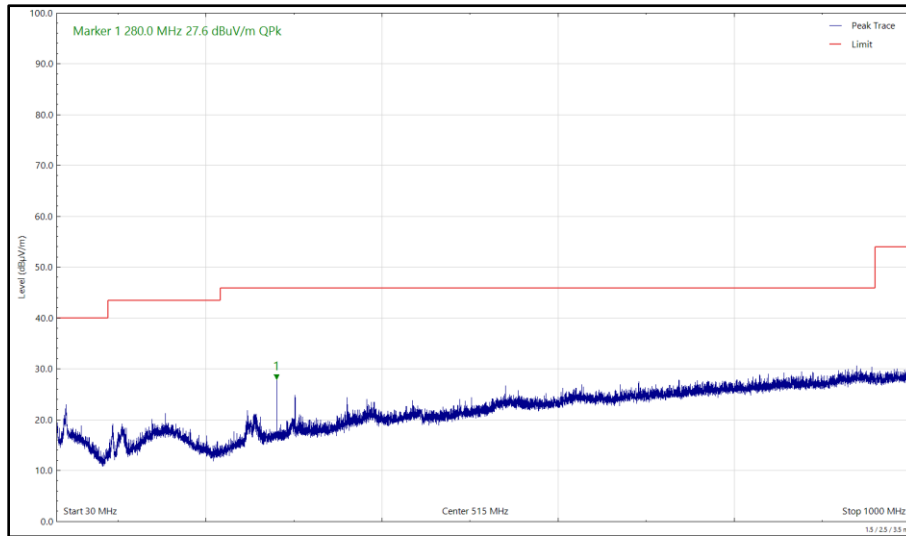

Figure 65 - 2440 MHz (CH18), Thread, iPA, Core 0, 30 MHz to 1 GHz, Horizontal (Peak)

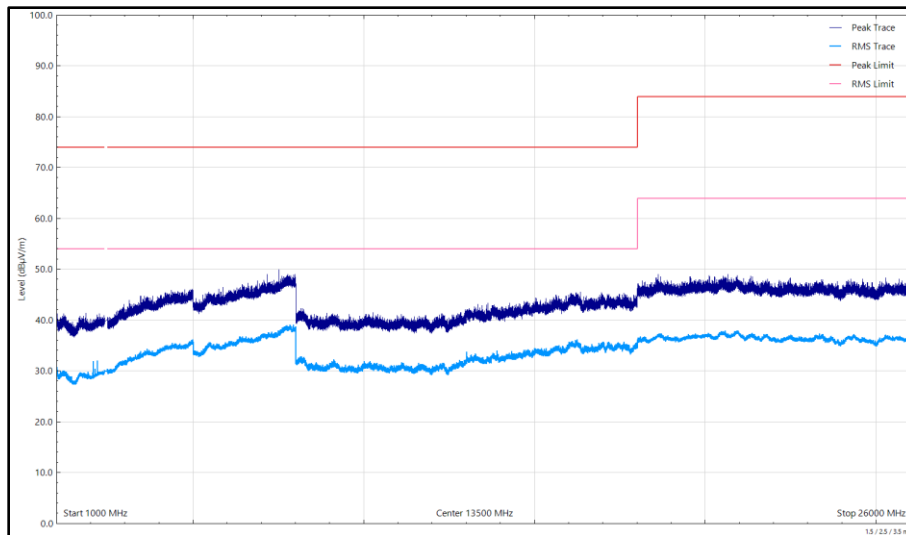

Figure 66 - 2440 MHz (CH18), Thread, iPA, Core 0, 1 GHz to 26 GHz, Horizontal

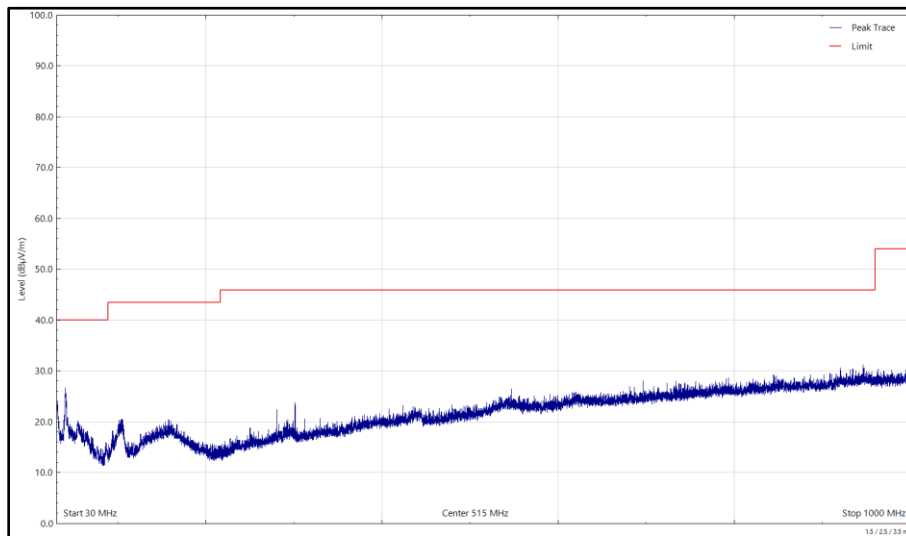

Figure 67 - 2440 MHz (CH18), Thread, iPA, Core 0, 30 MHz to 1 GHz, Vertical (Peak)

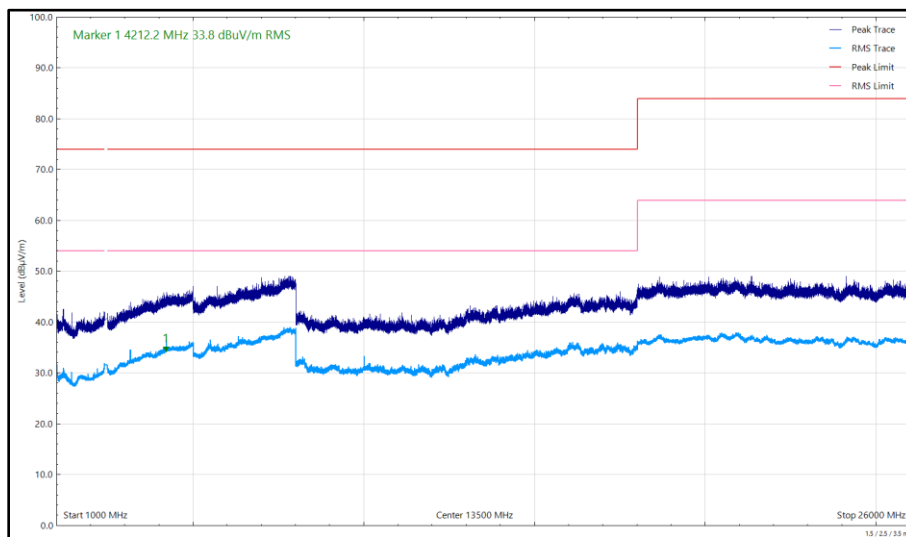

Figure 68 - 2440 MHz (CH18), Thread, iPA, Core 0, 1 GHz to 26 GHz, Vertical



Frequency (MHz)	Level (dBµV/m)	Limit (dBµV/m)	Margin (dB)	Detector	Angle (°)	Height (cm)	Polarisation
*							

Table 51 - 2475 MHz (CH25), Thread, iPA, Core 0, 1 GHz to 26 GHz

*No emissions found within 10 dB of the limit.

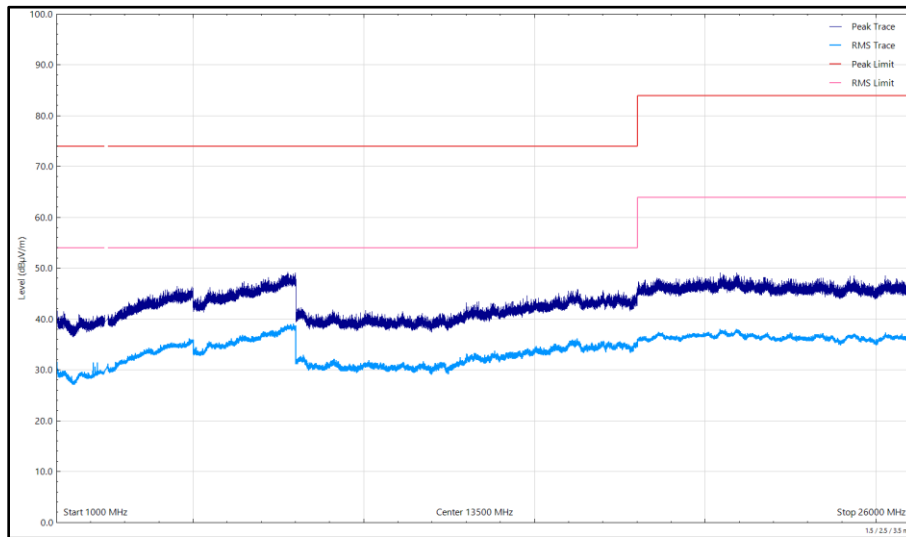

Figure 69 - 2475 MHz (CH25), Thread, iPA, Core 0, 1 GHz to 26 GHz, Horizontal

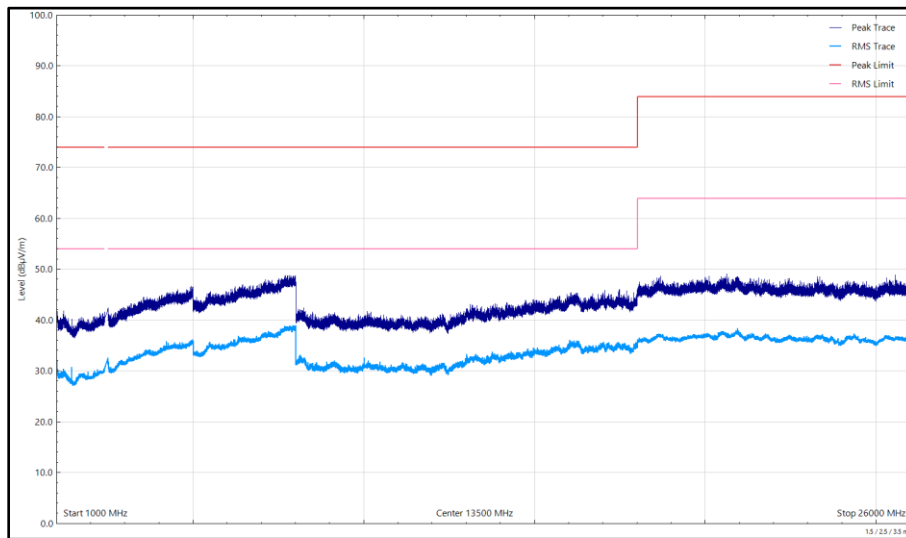

Figure 70 - 2475 MHz (CH25), Thread, iPA, Core 0, 1 GHz to 26 GHz, Vertical



Frequency (MHz)	Level (dBμV/m)	Limit (dBμV/m)	Margin (dB)	Detector	Angle (°)	Height (cm)	Polarisation
4207.149	33.33	54.00	-20.67	RMS	119	383	Vertical

Table 52 - 2405 MHz (CH11), Thread, iPA, Core 1, 1 GHz to 26 GHz

No other emissions found within 10 dB of the limit.

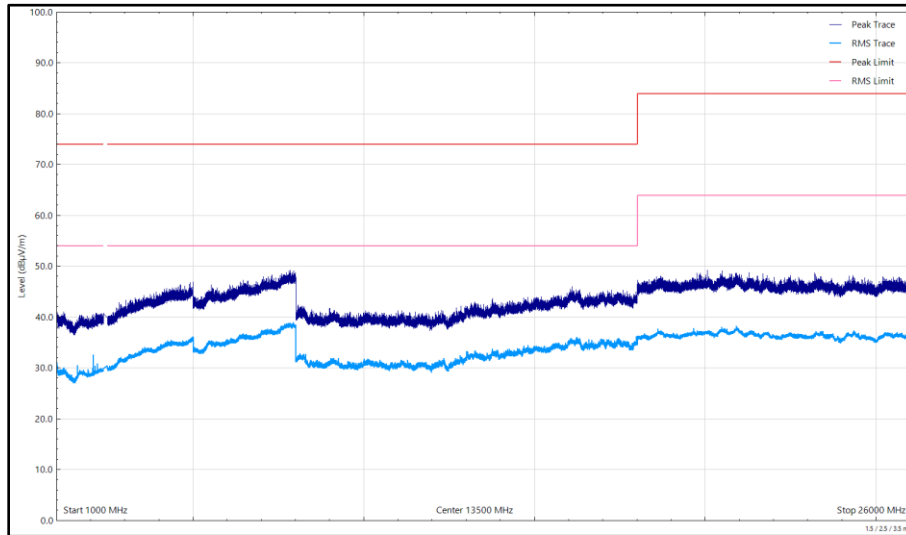

Figure 71 - 2405 MHz (CH11), Thread, iPA, Core 1, 1 GHz to 26 GHz, Horizontal

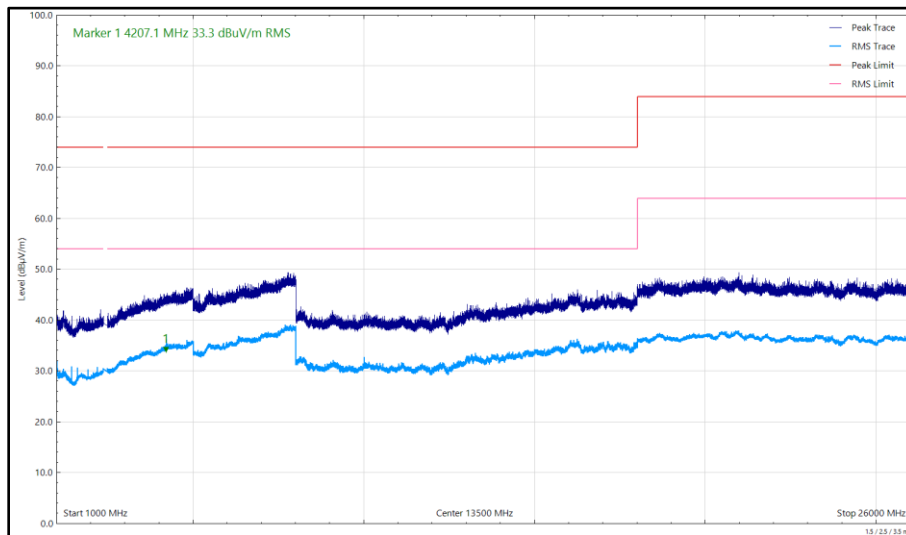

Figure 72 - 2405 MHz (CH11), Thread, iPA, Core 1, 1 GHz to 26 GHz, Vertical



Frequency (MHz)	Level (dBµV/m)	Limit (dBµV/m)	Margin (dB)	Detector	Angle (°)	Height (cm)	Polarisation
279.992	17.28	46.00	-28.72	Q-Peak	262	241	Horizontal
4207.523	33.35	54.00	-20.65	RMS	198	184	Vertical

Table 53 - 2440 MHz (CH18), Thread, iPA, Core 1, 30 MHz to 26 GHz

No other emissions found within 10 dB of the limit.

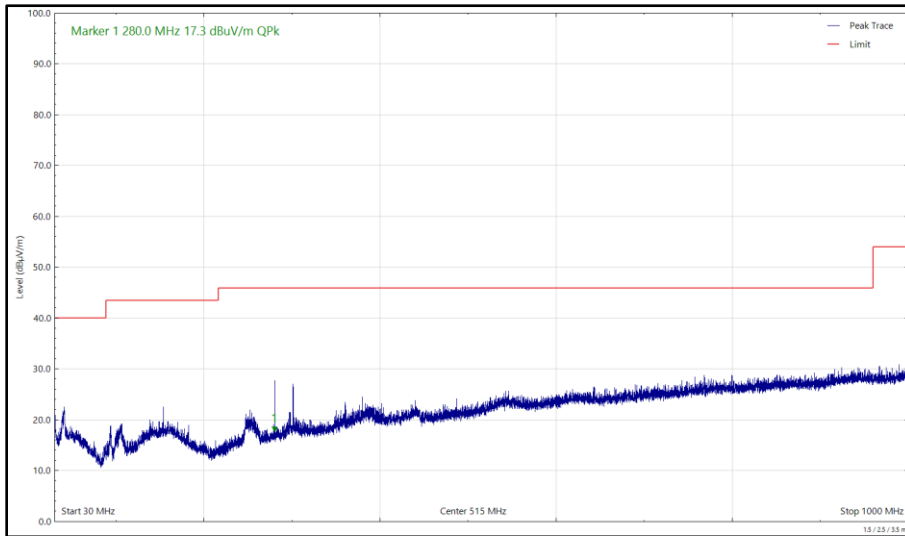

Figure 73 - 2440 MHz (CH18), Thread, iPA, Core 1, 30 MHz to 1 GHz, Horizontal (Peak)

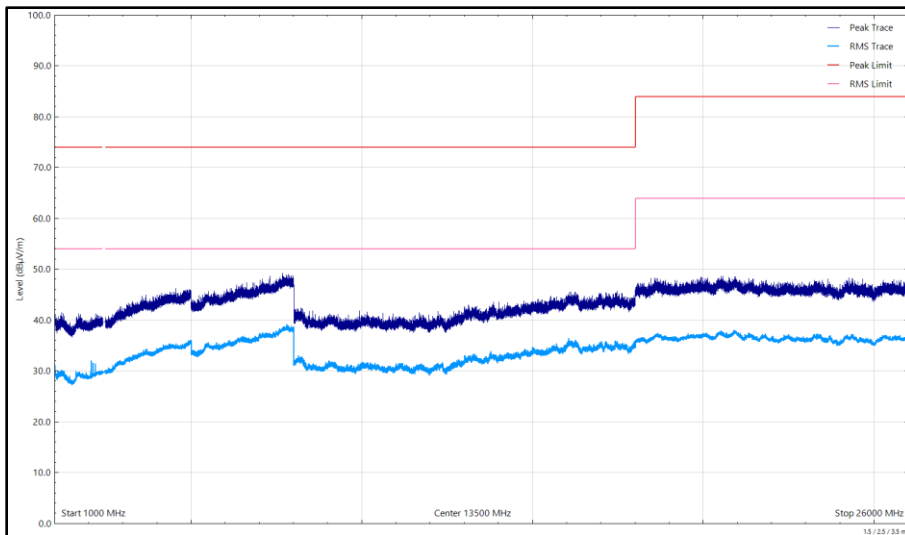

Figure 74 - 2440 MHz (CH18), Thread, iPA, Core 1, 1 GHz to 26 GHz, Horizontal

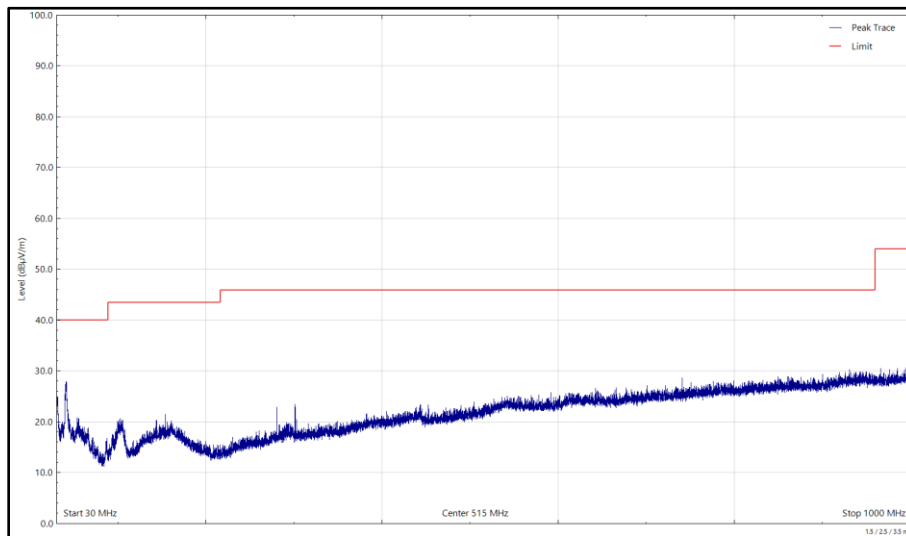

Figure 75 - 2440 MHz (CH18), Thread, iPA, Core 1, 30 MHz to 1 GHz, Vertical (Peak)

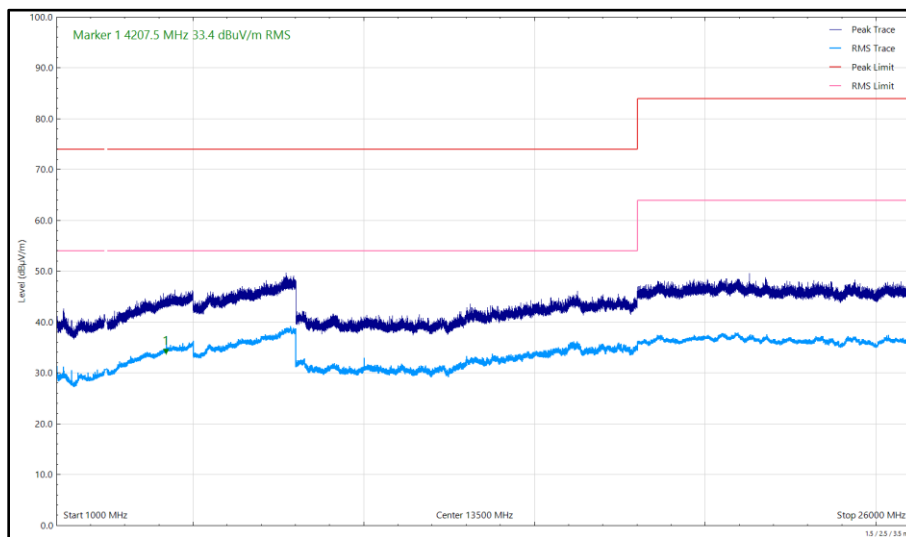

Figure 76 - 2440 MHz (CH18), Thread, iPA, Core 1, 1 GHz to 26 GHz, Vertical



Frequency (MHz)	Level (dBµV/m)	Limit (dBµV/m)	Margin (dB)	Detector	Angle (°)	Height (cm)	Polarisation
*							

Table 54 - 2475 MHz (CH25), Thread, iPA, Core 1, 1 GHz to 26 GHz

*No emissions found within 10 dB of the limit.

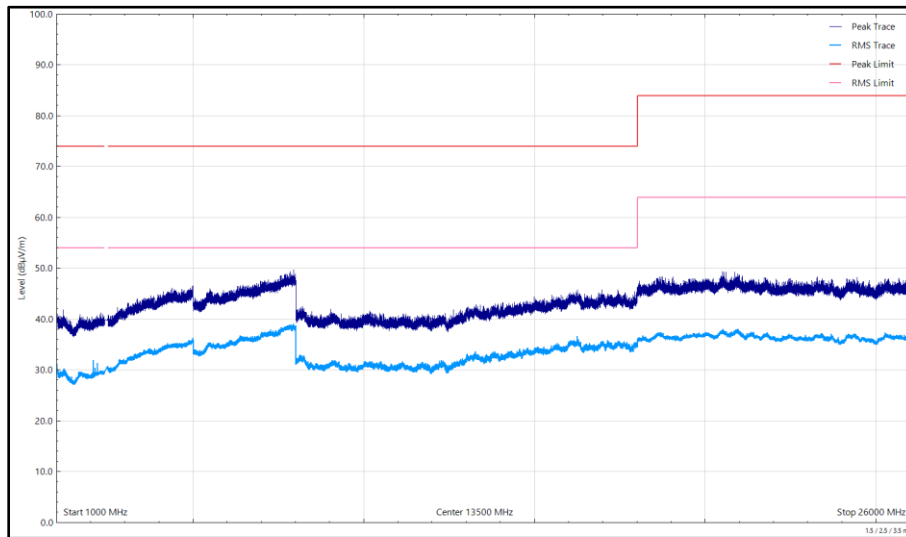

Figure 77 - 2475 MHz (CH25), Thread, iPA, Core 1, 1 GHz to 26 GHz, Horizontal

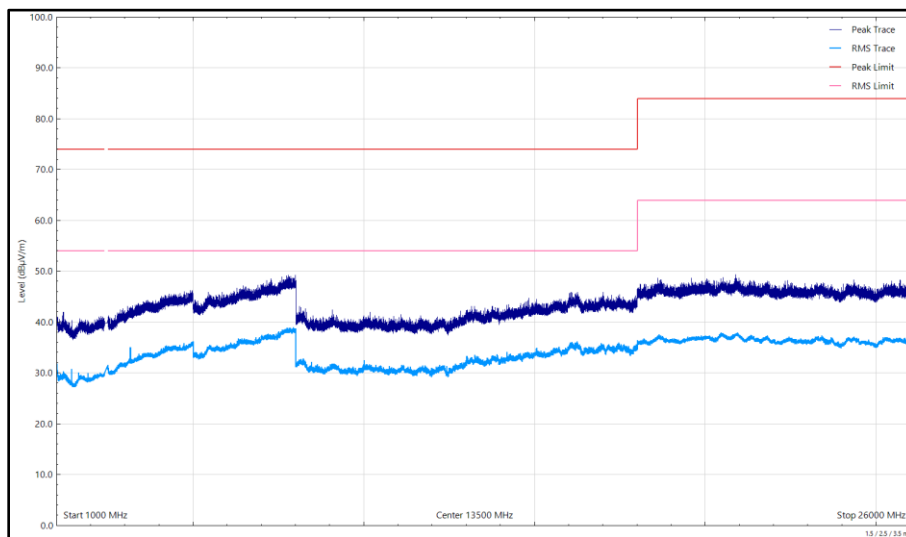

Figure 78 - 2475 MHz (CH25), Thread, iPA, Core 1, 1 GHz to 26 GHz, Vertical



Frequency (MHz)	Level (dBµV/m)	Limit (dBµV/m)	Margin (dB)	Detector	Angle (°)	Height (cm)	Polarisation
4211.888	35.13	54.00	-18.87	RMS	323	322	Vertical

Table 55 - 2405 MHz (CH11), Thread, iPA, Core 2, 1 GHz to 26 GHz

No other emissions found within 10 dB of the limit.

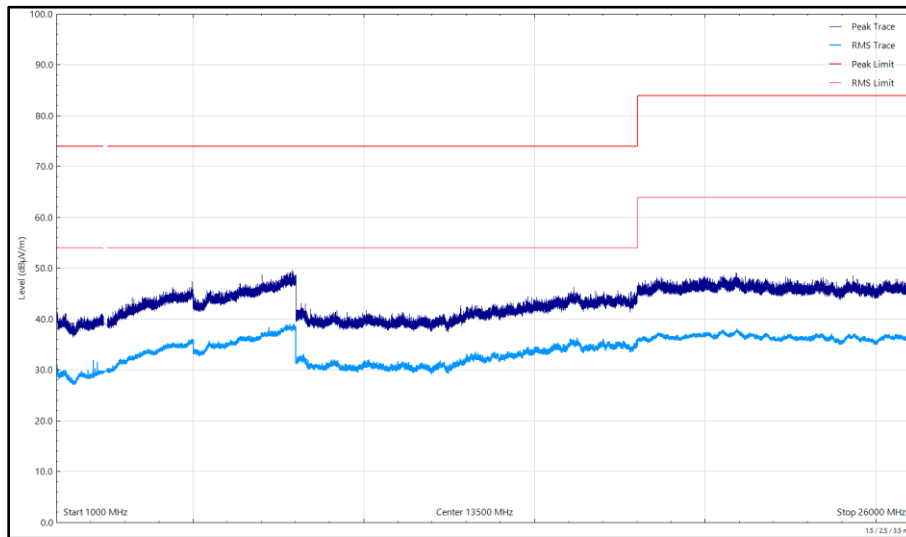

Figure 79 - 2405 MHz (CH11), Thread, iPA, Core 2, 1 GHz to 26 GHz, Horizontal

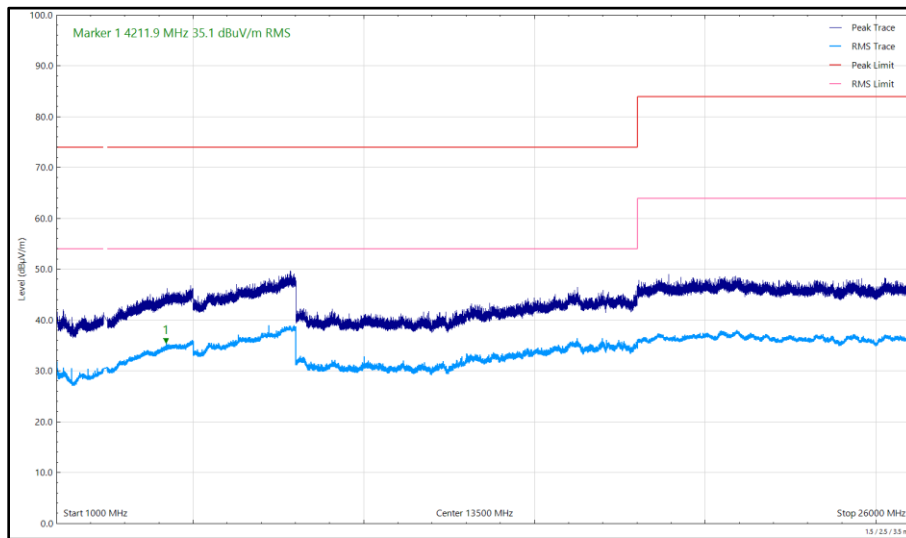

Figure 80 - 2405 MHz (CH11), Thread, iPA, Core 2, 1 GHz to 26 GHz, Vertical



Frequency (MHz)	Level (dBµV/m)	Limit (dBµV/m)	Margin (dB)	Detector	Angle (°)	Height (cm)	Polarisation
280.002	27.45	46.00	-18.55	Q-Peak	80	108	Horizontal
7319.980	39.68	54.00	-14.32	RMS	299	239	Vertical
7741.296	37.04	54.00	-16.96	RMS	185	278	Horizontal

Table 56 - 2440 MHz (CH18), Thread, iPA, Core 2, 30 MHz to 26 GHz

No other emissions found within 10 dB of the limit.

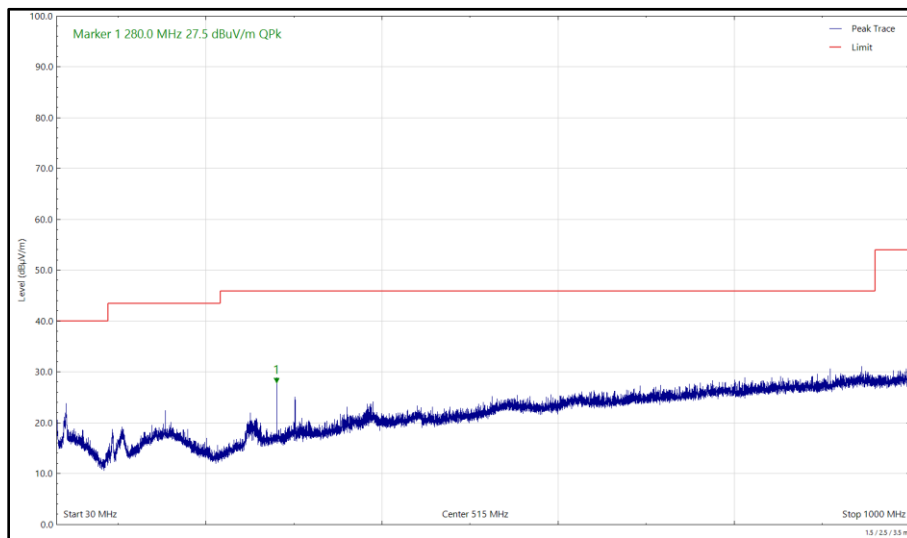

Figure 81 - 2440 MHz (CH18), Thread, iPA, Core 2, 30 MHz to 1 GHz, Horizontal (Peak)

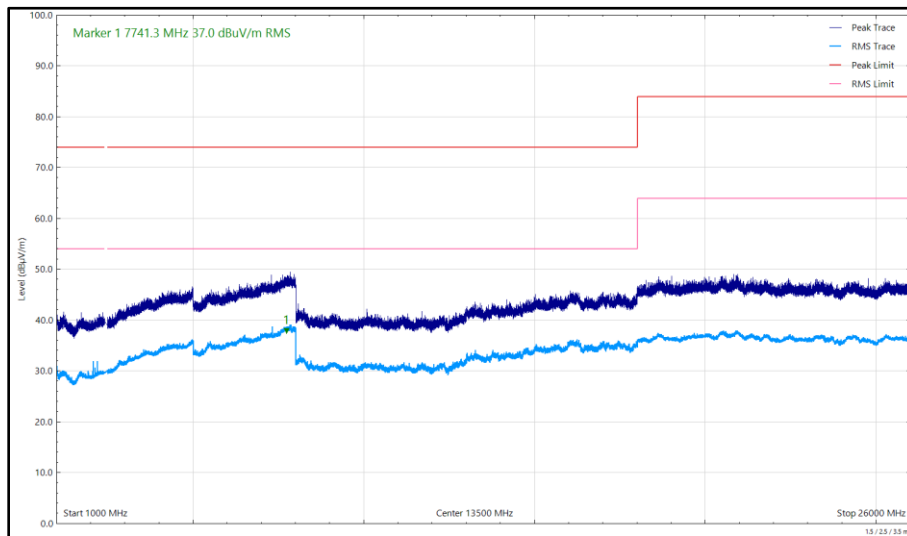

Figure 82 - 2440 MHz (CH18), Thread, iPA, Core 2, 1 GHz to 26 GHz, Horizontal

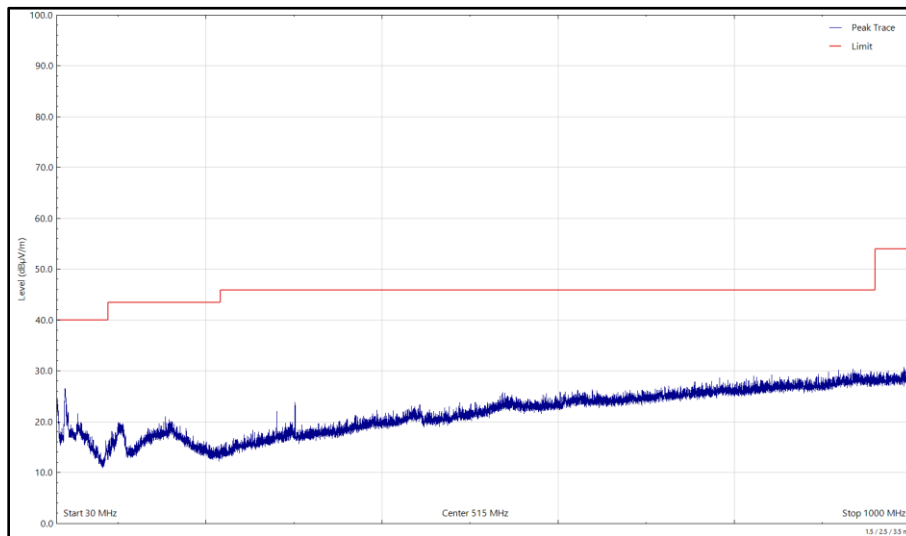

Figure 83 - 2440 MHz (CH18), Thread, iPA, Core 2, 30 MHz to 1 GHz, Vertical (Peak)

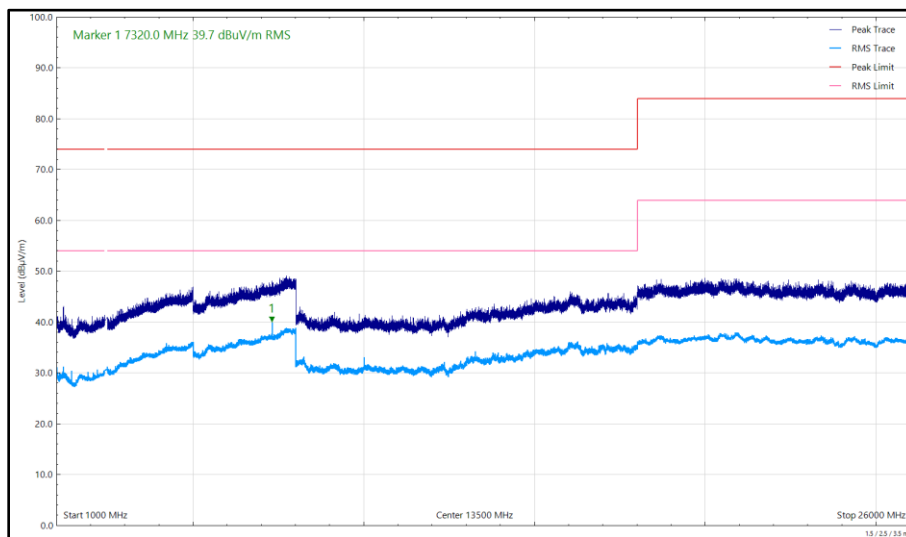

Figure 84 - 2440 MHz (CH18), Thread, iPA, Core 2, 1 GHz to 26 GHz, Vertical



Frequency (MHz)	Level (dBµV/m)	Limit (dBµV/m)	Margin (dB)	Detector	Angle (°)	Height (cm)	Polarisation
4205.929	33.32	54.00	-20.68	RMS	139	182	Vertical
7423.735	35.96	54.00	-18.04	RMS	285	100	Horizontal
7424.980	37.26	54.00	-16.74	RMS	356	100	Vertical

Table 57 - 2475 MHz (CH25), Thread, iPA, Core 2, 1 GHz to 26 GHz

No other emissions found within 10 dB of the limit.

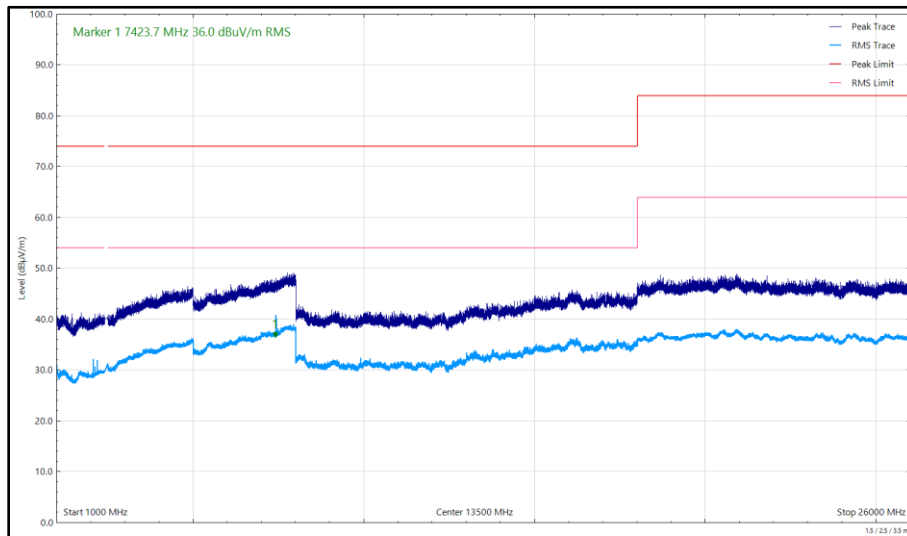

Figure 85 - 2475 MHz (CH25), Thread, iPA, Core 2, 1 GHz to 26 GHz, Horizontal

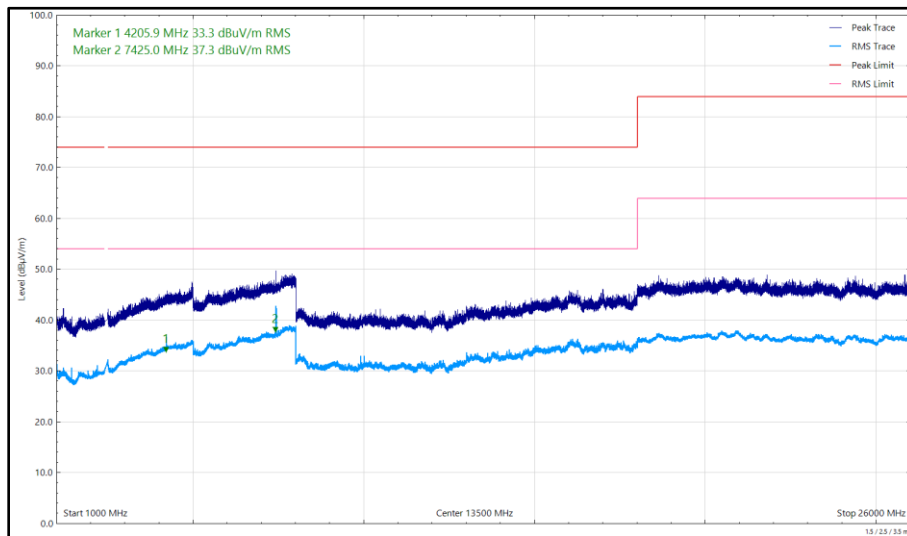

Figure 86 - 2475 MHz (CH25), Thread, iPA, Core 2, 1 GHz to 26 GHz, Vertical



FCC 47 CFR Part 15, Limit Clause 15.247 (d)

In any 100 kHz bandwidth outside the frequency band in which the spread spectrum or digitally modulated intentional radiator is operating, the radio frequency power that is produced by the intentional radiator shall be at least 20 dB below that in the 100 kHz bandwidth within the band that contains the highest level of the desired power, based on either an RF conducted or a radiated measurement, provided the transmitter demonstrates compliance with the peak conducted power limits. If the transmitter complies with the conducted power limits based on the use of RMS averaging over a time interval, as permitted under paragraph (b)(3) of this section, the attenuation required under this paragraph shall be 30 dB instead of 20 dB.

Attenuation below the general limits specified in § 15.209(a) is not required. In addition, radiated emissions which fall in the restricted bands, as defined in § 15.205(a), must also comply with the radiated emission limits specified in 15.209(a)

ISED RSS-247, Limit Clause 5.5

In any 100 kHz bandwidth outside the frequency band in which the spread spectrum or digitally modulated device is operating, the RF power that is produced shall be at least 20 dB below that in the 100 kHz bandwidth within the band that contains the highest level of the desired power, based on either an RF conducted or a radiated measurement, provided that the transmitter demonstrates compliance with the peak conducted power limits. If the transmitter complies with the conducted power limits based on the use of root-mean-square averaging over a time interval, as permitted under Section 5.4(4), the attenuation required shall be 30 dB instead of 20 dB. Attenuation below the general field strength limits specified in RSS-Gen is not required.

In addition, radiated emissions which fall in the restricted bands, as defined in RSS-GEN, clause 8.10, must also comply with the radiated emission limits specified in RSS-GEN clause 8.9.



2.5.8 Test Location and Test Equipment Used

This test was carried out in RF Chamber 16 and RF Chamber 17.

Instrument	Manufacturer	Type No.	TE No.	Calibration Period (months)	Calibration Expiry Date
Emissions Software	TUV SUD	EmX V3.2.0	5125	-	Software
Cable 2.92m	Junkosha	MWX241-01000KMS	5413	12	23-May-2025
EMI Test Receiver	Rohde & Schwarz	ESW44	5911	12	11-Sep-2024
DRG Horn Antenna (7.5-18GHz)	Schwarzbeck	HWRD750	5939	12	05-May-2025
TRILOG Super Broadband Test Antenna	Schwarzbeck	VULB 9168	5943	24	24-May-2026
1500W (300V 12A) AC Power Supply	iTech	IT7324	5957	-	O/P Mon
3m Semi-Anechoic Chamber, Chamber16	Albatross Projects	RF Chamber 16	5972	36	24-May-2025
Mast & Turntable Controller	Maturo Gmbh	FCU3.0	5973	-	TU
Tilt Antenna Mast	Maturo Gmbh	BAM4.5-P	5974	-	TU
Turntable	Maturo Gmbh	TT1.5SI	5975	-	TU
Cable (SMA to SMA 3m)	Junkosha	MWX221-03000AMSAMS/A	6021	12	14-Sep-2024
Horn Antenna (1-10 GHz)	Schwarzbeck	BBHA9120B	6142	12	05-May-2025
Digital Multimeter	Fluke	115	6145	12	06-Jun-2025
Digital Multimeter	Fluke	115	6146	12	06-Jun-2025
Double Ridge Active Horn Antenna (18-40 GHz)	Com-Power	AHA-840	6189	24	31-Aug-2024
EMI Test Receiver	Rohde & Schwarz	ESW44	6294	12	06-Jan-2025
USB Spectrum Analyser	Signal Hound	SA124B	6295	-	TU
Cable (SMA to SMA 8m)	Junkosha	MWX221-08000AMSAMS/B	6319	12	04-Feb-2025
Cable (K Type 2m)	Junkosha	MWX241-02000KMSKMS/B	6324	12	04-Feb-2025
SAC Switch Unit	TUV SUD	TUV_SSU_004 PLC	6349	12	07-May-2025
USB Spectrum Analyser	Signal Hound	SA124B	6383	-	TU
8 GHz High Pass Filter	Wainwright	WHKX 7150 8000 18000 50SS	6427	12	23-Apr-2025
Humidity and Temperature Meter	R.S Components	1364	6486	12	04-Jun-2025
Coax cable sma to sma with N-Type adapter	TUV SUD	N/A	6637	12	23-Apr-2025
3m Semi-Anechoic Chamber	Albatross Projects	RF Chamber 17	6658	36	28-Jan-2026
Mast and Turntable Controller	Maturo Gmbh	FCU3.0	6659	-	TU
Tilt Antenna Mast	Maturo Gmbh	BAM4.5-P	6660	-	TU
Turntable	Maturo Gmbh	TT1.5SI	6661	-	TU



Instrument	Manufacturer	Type No.	TE No.	Calibration Period (months)	Calibration Expiry Date
8m Cable	Junkosha	MWX221-08000AMSAMS/B	6748	12	01-Feb-2025
Pre Amp 8 - 18 GHz	Wright Technologies	APS06-0061	6783	12	23-Apr-2025
AC Programmable Power Supply	iTech	IT7324	6812	-	O/P Mon

Table 58

TU - Traceability Unscheduled
O/P Mon - Output Monitored using calibrated equipment



2.6 Power Spectral Density

2.6.1 Specification Reference

FCC 47 CFR Part 15C, Clause 15.247 (e)
ISED RSS-247, Clause 5.2
ISED RSS-GEN, Clause 6.12

2.6.2 Equipment Under Test and Modification State

A3112, S/N: DQHQ6Q99MH - Modification State 0

2.6.3 Date of Test

15-July-2024

2.6.4 Test Method

This test was performed in accordance with ANSI C63.10, clause 11.10.5.

2.6.5 Environmental Conditions

Ambient Temperature	20.3 °C
Relative Humidity	55.5 %



2.6.6 Test Results

Thread

Test Configuration			
Frequency Range:	2400-2483.5 MHz	Band:	2.4 GHz
Limit Clause(s):	15.247 (e) RSS-247 5.2 b)	Test Method(s):	C63.10 11.10.5
Additional Reference(s):	-		
Note(s):	DCCF was added to the spectrum analyser reference level offset.		

DUT Configuration			
Mode:	Thread iPA	Duty Cycle (%):	88.9
Data Rate:	-	DCCF (dB):	0.51
Antenna Configuration:	SISO	Peak Antenna Gain (dBi):	-
Active Port(s):	A (Core 0)	Active Chain(s):	0

Test Frequency (MHz)	RBW (kHz)	PSD (dBm/RBW)					Limit (dBm/3 kHz)	Margin (dB)
		A	B	C	D	Σ		
2405	3.0	-9.55	-	-	-	-9.5	8.00	-17.55
2440	3.0	-10.84	-	-	-	-10.8	8.00	-18.84
2475	3.0	-10.09	-	-	-	-10.1	8.00	-18.09

Table 59 - Maximum Power Spectral Density Results

Test Configuration			
Frequency Range:	2400-2483.5 MHz	Band:	2.4 GHz
Limit Clause(s):	15.247 (e) RSS-247 5.2 b)	Test Method(s):	C63.10 11.10.5
Additional Reference(s):	-		
Note(s):	DCCF was added to the spectrum analyser reference level offset.		

DUT Configuration			
Mode:	Thread ePA	Duty Cycle (%):	88.9
Data Rate:	-	DCCF (dB):	0.51
Antenna Configuration:	SISO	Peak Antenna Gain (dBi):	-
Active Port(s):	A (Core 0)	Active Chain(s):	0

Test Frequency (MHz)	RBW (kHz)	PSD (dBm/RBW)					Limit (dBm/3 kHz)	Margin (dB)
		A	B	C	D	Σ		
2405	3.0	-2.27	-	-	-	-2.3	8.00	-10.27
2440	3.0	-2.18	-	-	-	-2.2	8.00	-10.18
2475	3.0	-2.22	-	-	-	-2.2	8.00	-10.22

Table 60 - Maximum Power Spectral Density Results



Test Configuration			
Frequency Range:	2400-2483.5 MHz	Band:	2.4 GHz
Limit Clause(s):	15.247 (e) RSS-247 5.2 b)	Test Method(s):	C63.10 11.10.5
Additional Reference(s):	-		
Note(s):	DCCF was added to the spectrum analyser reference level offset.		

DUT Configuration			
Mode:	Thread iPA	Duty Cycle (%):	88.9
Data Rate:	-	DCCF (dB):	0.51
Antenna Configuration:	SISO	Peak Antenna Gain (dBi):	-
Active Port(s):	B (Core 1)	Active Chain(s):	1

Test Frequency (MHz)	RBW (kHz)	PSD (dBm/RBW)					Limit (dBm/3 kHz)	Margin (dB)
		A	B	C	D	Σ		
2405	3.0	-	-10.52	-	-	-10.5	8.00	-18.52
2440	3.0	-	-9.97	-	-	-10.0	8.00	-17.97
2475	3.0	-	-10.07	-	-	-10.1	8.00	-18.07

Table 61 - Maximum Power Spectral Density Results

Test Configuration			
Frequency Range:	2400-2483.5 MHz	Band:	2.4 GHz
Limit Clause(s):	15.247 (e) RSS-247 5.2 b)	Test Method(s):	C63.10 11.10.5
Additional Reference(s):	-		
Note(s):	DCCF was added to the spectrum analyser reference level offset.		

DUT Configuration			
Mode:	Thread ePA	Duty Cycle (%):	88.9
Data Rate:	-	DCCF (dB):	0.51
Antenna Configuration:	SISO	Peak Antenna Gain (dBi):	-
Active Port(s):	B (Core 1)	Active Chain(s):	1

Test Frequency (MHz)	RBW (kHz)	PSD (dBm/RBW)					Limit (dBm/3 kHz)	Margin (dB)
		A	B	C	D	Σ		
2405	3.0	-	-2.53	-	-	-2.5	8.00	-10.53
2440	3.0	-	-2.32	-	-	-2.3	8.00	-10.32
2475	3.0	-	-2.01	-	-	-2.0	8.00	-10.01

Table 62 - Maximum Power Spectral Density Results



Test Configuration			
Frequency Range:	2400-2483.5 MHz	Band:	2.4 GHz
Limit Clause(s):	15.247 (e) RSS-247 5.2 b)	Test Method(s):	C63.10 11.10.5
Additional Reference(s):	-		
Note(s):	DCCF was added to the spectrum analyser reference level offset.		

DUT Configuration			
Mode:	Thread iPA	Duty Cycle (%):	88.9
Data Rate:	-	DCCF (dB):	0.51
Antenna Configuration:	SISO	Peak Antenna Gain (dBi):	-
Active Port(s):	C (Core 2)	Active Chain(s):	2

Test Frequency (MHz)	RBW (kHz)	PSD (dBm/RBW)					Limit (dBm/3 kHz)	Margin (dB)
		A	B	C	D	Σ		
2405	3.0	-	-	-10.91	-	-10.9	8.00	-18.91
2440	3.0	-	-	-10.76	-	-10.8	8.00	-18.76
2475	3.0	-	-	-10.97	-	-11.0	8.00	-18.97

Table 63 - Maximum Power Spectral Density Results

FCC 47 CFR Part 15, Limit Clause 15.247 (e)

The power spectral density conducted from the intentional radiator to the antenna shall not be greater than 8 dBm in any 3 kHz band during any time interval of continuous transmission.

ISED RSS-247, Limit Clause 5.2(b)

The transmitter power spectral density conducted from the transmitter to the antenna shall not be greater than 8 dBm in any 3 kHz band during any time interval of continuous transmission.



2.6.7 Test Location and Test Equipment Used

This test was carried out in RF Laboratory 14.

Instrument	Manufacturer	Type No.	TE No.	Calibration Period (months)	Calibration Expiry Date
Hygrometer	Rotronic	I-1000	3068	12	07-Nov-2024
Digital Multimeter	Fluke	115	6145	12	06-Jun-2025
MXA Signal Analyser	Keysight Technologies	N9020B	6417	24	26-Feb-2025
Signal Conditioning Unit	TUV SUD	SPECTRUM_SCU001	6518	12	16-Feb-2025
SCU Cable Assembly	TUV SUD	SPECTRUM_SCU_CA	6529	12	16-Feb-2025
SCU Cable Assembly	TUV SUD	SPECTRUM_SCU_CA	6530	12	16-Feb-2025
SCU Cable Assembly	TUV SUD	SPECTRUM_SCU_CA	6531	12	16-Feb-2025
USB Wideband Power Sensor	Boonton	RTP5008	6587	12	13-Feb-2025
USB Wideband Power Sensor	Boonton	RTP5008	6588	12	13-Feb-2025
USB Wideband Power Sensor	Boonton	RTP5008	6589	12	13-Feb-2025
AC Programmable Power Supply	iTech	IT7324	6662	-	O/P Mon

Table 64

O/P Mon - Output Monitored using calibrated equipment



3 Measurement Uncertainty

For a 95% confidence level, the measurement uncertainties for defined systems are:

Test Name	Measurement Uncertainty
Restricted Band Edges	30 MHz to 1 GHz: ± 5.2 dB 1 GHz to 40 GHz: ± 6.3 dB
Emission Bandwidth	± 88.86 kHz
Maximum Conducted Output Power	± 1.38 dB
Authorised Band Edges	30 MHz to 1 GHz: ± 5.2 dB 1 GHz to 40 GHz: ± 6.3 dB
Spurious Radiated Emissions	30 MHz to 1 GHz: ± 5.2 dB 1 GHz to 40 GHz: ± 6.3 dB
Power Spectral Density	± 1.49 dB

Table 65

Measurement Uncertainty Decision Rule – Accuracy Method

Determination of conformity with the specification limits is based on the decision rule according to IEC Guide 115:2021, Clause 4.4.3 (Procedure 2). The measurement results are directly compared with the test limit to determine conformance with the requirements of the standard.

Risk: The uncertainty of measurement about the measured result is negligible with regard to the final pass/fail decision. The measurement result can be directly compared with the test limit to determine conformance with the requirement (compare IEC Guide 115). The level of risk to falsely accept and falsely reject items is further described in ILAC-G8.