



**Add value.
Inspire trust.**

TUV SUD Digitally signed by
TUV SUD
Date: 2023.10.11
10:54:18 +01'00'

Report On

Specific Absorption Rate Testing of the A2992

In accordance with FCC 47CFR 2.1093
FCC ID: BCGA2992

COMMERCIAL-IN-CONFIDENCE

Document 75958013 Report 9 Issue 1

October 2023





TÜV SÜD Product Service, Octagon House, Concorde Way, Segensworth North,
Fareham, Hampshire, United Kingdom, PO15 5RL
Tel: +44 (0) 1489 558100. Website: <http://www.tuvsud.com>

COMMERCIAL-IN-CONFIDENCE

REPORT ON Specific Absorption Rate Testing of the A2992
Document 75958013 Report 9 Issue 1
October 2023

PREPARED FOR Apple Inc
One Apple Park Way
Cupertino
California 95014
USA

PREPARED BY 
Kamil Nawabzada
Technician (SAR)

APPROVED BY 
Jon Kenny
Authorised Signatory

DATED 11 October 2023



CONTENTS

Section	Page No
1	REPORT SUMMARY 3
1.1	Introduction 4
1.2	Brief Summary of Results 5
1.3	Test Results Summary 7
1.4	Power Tables (Tune Up Values) 26
1.5	Conducted Power Measurements 52
2	TEST DETAILS 66
2.1	DASY6 Measurement System 67
3	TEST EQUIPMENT USED 75
3.1	Test Equipment Used 76
3.2	Test Software 78
3.3	Dielectric Properties of Simulant Liquids 79
3.4	Test Conditions 80
3.5	Measurement Uncertainty 81
4	ACCREDITATION, DISCLAIMERS AND COPYRIGHT 88
4.1	Accreditation, Disclaimers and Copyright 89
ANNEX A	Probe Calibration Reports A.2
ANNEX B	Dipole Calibration Reports B.2
ANNEX C	SAR Plots C.2
ANNEX D	Thread Technology Duty Factor Correction D.2



SECTION 1

REPORT SUMMARY

Specific Absorption Rate Testing of the A2992



1.1 INTRODUCTION

The information contained in this report is intended to show verification of the Specific Absorption Rate Testing of the A2992 to the requirements of FCC 47CFR 2.1093

Objective	To perform Specific Absorption Rate Testing to determine the Equipment Under Test's (EUT's) compliance with the requirements specified of FCC 47CFR 2.1093 for the series of tests carried out.
Applicant	Apple Inc
Manufacturer	Apple Inc
Manufacturing Description	Laptop Computer
Model Number	A2992
Serial/IMEI Number(s)	M6LGJJW42K (Conducted) PYY4D46T97 (Radiated)
Number of Samples Tested	2
Hardware Version	REV 1.0
Software Version	23A32391n (Conducted) 23A32391n (Radiated)
Test Specification/Issue/Date	FCC 47CFR 2.1093
Start of Test	17-August-2023
Finish of Test	06-September-2023
Related Document(s)	KDB 865664 – D01 v01r04 KDB 447498 – D01 v06 IEC-IEEE 62209-1528-2020 KDB 248227 – D01 v02r02 IEC/IEEE 63195-1:2022 ICNIRP 2020 FCC 47 CFR 1.1310 SPEAG, DASY8 Application Note: SAR, APD & PD at 6 - 10 GHz (Version 6.0), August 2022 October 2020 TCBC Workshop Notes
Name of Engineer(s)	Kamil Nawabzada Gualberta Madeira Valentinas Luza Sruthy Sudevan Umesh Kabbur



1.2 BRIEF SUMMARY OF RESULTS

The measurements shown in this report were made to the requirements of FCC 47CFR 2.1093

The maximum 1g volume averaged stand-alone SAR found during this Assessment:

Max 1g SAR (W/kg) Body	0.812 (Measured)	1.075 (Scaled)
The maximum 1g volume averaged SAR level measured for all the tests performed did not exceed the limits for FCC General Population/Uncontrolled Exposure (W/kg) Partial Body of 1.6 W/kg in accordance with FCC 47 CFR 1.1310		

The maximum iPD 4cm² found during this Assessment:

Max iPD 4cm ² (W/m ²)	6.14 (Measured)
The maximum iPD averaged over 4cm ² measured for all the tests performed did not exceed the standalone limits for FCC General Population/Uncontrolled Exposure of 10.00 W/m ² in accordance with FCC 47 CFR 1.1310.	

The maximum 1g volume averaged stand-alone Reported SAR found during this Assessment for each supported mode:

RAT	Band	Test Configuration	Max Reported SAR (W/kg)
Bluetooth (5 or 6 GHz WLAN OFF)	2450 MHz	Body	0.413
Bluetooth (5 or 6 GHz WLAN ON)	2450 MHz	Body	0.328
Narrowband (2.4 GHz WLAN OFF)	5150-5250 MHz 5725-5850 MHz	Body	1.075
Narrowband (2.4 GHz WLAN ON)	5150-5250 MHz 5725-5850 MHz	Body	0.480
Thread (5 or 6 GHz OFF)	2450 MHz	Body	0.398*
Thread (5 or 6 GHz ON)	2450 MHz	Body	0.220*
WLAN	2450 MHz	Body	0.841
WLAN	5200 / 5300 MHz	Body	0.842
WLAN	5500 / 5600 MHz	Body	0.781
WLAN	5800 MHz	Body	0.762
WLAN	6000MHz	Body	0.485
The maximum 1g volume averaged SAR level measured for all the tests performed (including simultaneous transmission analysis results) did not exceed the limits for General Population/Uncontrolled Exposure (W/kg) Partial Body of 1.6 W/kg.			
* Measured results for Thread RAT were scaled down from 100% duty cycle to 60.61%. Refer to Annex D			



Simultaneous Transmission.

The combinations of simultaneous transmission this EUT can achieve are the following:

- 2.4 GHz WLAN + 5 GHz Narrowband
- 5 or 6 GHz WLAN + 2.4 GHz Bluetooth
- 5 or 6 GHz WLAN + 2.4 GHz Thread

Position	2.4 GHz WLAN 1g SAR (W/kg) (Core 0)	Narrowband (2.4 GHz WLAN ON) 1g SAR(W/kg) (Core 0)	Sum of 1g SAR (W/Kg)	Peak Location Separation Ratio required?	Peak Location Separation Ratio
Bottom	0.841	0.480	1.321	No	N/A

Position	5 or 6 GHz WLAN - 1g SAR (W/kg) (Core 0)	Bluetooth (5 or 6 GHz WLAN on) 1g SAR (W/kg) (Core 0)	Sum of 1g SAR (W/Kg)	Peak Location Separation Ratio required?	Peak Location Separation Ratio
Bottom	0.803	0.328	1.131	No	N/A

Position	5 or 6 GHz WLAN - 1g SAR (W/kg) (Core 0)	Thread (5 or 6 GHz on) 1g SAR (W/kg) (Core 0)	Sum of 1g SAR (W/Kg)	Peak Location Separation Ratio required?	Peak Location Separation Ratio
Bottom	0.803	0.220	1.023	No	N/A

Position	6 GHz WLAN - Exposure Ratio (Core 1)	Bluetooth (5/6 GHz WLAN on) Exposure ratio (Core 1)	Total Exposure Ratio	Total Exposure Ratio less than 1.0
Bottom	0.614	0.205	0.819	Yes

Each antenna is separated to the extent that the SAR distributions do not overlap and only same core simultaneous transmission is considered.

Bluetooth/NB/Thread and 2.4/5/6 GHz WLAN can operate on the same antenna.

BT/Thread operates at a lower power when 5/6 GHz WLAN is active.

NB operates at a lower power when 2.4 GHz WLAN is active.

The highest overall reported SAR values of the same antenna of 2.4/5/6 GHz WLAN and Bluetooth/NB/Thread (2.4/5/6 GHz WLAN on) results were used for the summation of the simultaneous transmission as shown in the table above.

KDB 447498 D01 - Section 4.3.2: Simultaneous test exclusion is applicable as the sum of 1g SAR of all simultaneously transmitting antennas in an operating mode and exposure condition combination is within the SAR limit or within the Peak Location Separation Ratio.



1.3 TEST RESULTS SUMMARY

1.3.1 System Performance / Validation Check Results

Prior to formal testing being performed a System Check was performed in accordance with KDB 865664 and the results were compared against the calibration certificates of each corresponding system verification dipole. A system performance check in DASY6 Module mmWave was also performed with the Verification Source available at 10 GHz in accordance with IEC/IEEE 63195. The following results were obtained and within the $\pm 10\%$ acceptance criteria : -

System performance / Validation results

Date	Frequency (MHz)	Fluid Type	Measured Max 1g SAR (W/kg) *	Max 1g SAR Target (W/kg)	Percentage Deviation from Target 1g (%)
17/08/2023	2450	HBBL/B1	49.08	50.50	-2.81
18/08/2023	2450	HBBL/B1	51.08	50.50	1.15
19/08/2023	2450	HBBL/B1	51.08	50.50	1.15
29/08/2023	2450	HBBL/B1	49.08	50.50	-2.81
23/08/2023	5200	HBBL/B1	72.23	78.20	-7.64
29/08/2023	5200	HBBL/B1	73.23	78.20	-6.36
30/08/2023	5200	HBBL/B1	72.23	78.20	-7.64
01/09/2023	5200	HBBL/B1	74.82	78.20	-4.32
30/08/2023	5500	HBBL/B1	76.82	84.70	-9.31
31/08/2023	5500	HBBL/B1	79.81	84.70	-5.77
30/08/2023	5600	HBBL/B1	83.20	84.20	-1.18
31/08/2023	5600	HBBL/B1	86.20	84.20	2.37
23/08/2023	5800	HBBL/B1	72.23	78.20	-7.64
25/08/2023	5800	HBBL/B1	76.02	80.50	-5.57
25/08/2023	6500	HBBL/B1	289.00	277.00	4.33
01/09/2023	6500	HBBL/B1	291.00	277.00	5.05
03/09/2023	6500	HBBL/B1	276.00	277.00	-0.36
04/09/2023	6500	HBBL/B1	290.00	277.00	4.69
05/09/2023	6500	HBBL/B1	290.00	277.00	4.69

Date	Frequency (MHz)	Fluid Type	Absorbed Power Density over 4cm ² (W/m ²)*	Absorbed Power Density Target over 4cm ² (W/m ²)	Percentage Deviation from Target 4cm ² (%)
25/08/2023	6500	HBBL/B1	1296	1250	3.68
01/09/2023	6500	HBBL/B1	1314	1250	5.12
03/09/2023	6500	HBBL/B1	1264	1250	1.12
04/09/2023	6500	HBBL/B1	1320	1250	5.60
05/09/2023	6500	HBBL/B1	1220	1250	-2.40

Date	Frequency (MHz)	Medium	Measured psPDtot+ (W/m ²)	Target psPDtot+ (W/m ²)	Percentage Deviation from Target (%)
13/09/2023	10000	Air	53.90	50.10	7.58

*Normalised to a forward power of 1W



1.3.2 Results Summary Tables

Bluetooth - EDR – 3-DH5 – SISO Core 0 (5 or 6 GHz WLAN OFF) (ePA):
Body Specific Absorption Rate (SAR) 1g Results

Test Position	Channel Number	Frequency (MHz)	Measured Average Power (dBm)	Tune Up (dBm)	SAR Scan Type	Measured 1g SAR (W/kg)	Scaled 1g SAR (W/kg)	Scan Figure Number
0mm Rear of Display	39	2441	14.62	16.50	Full	0.080	0.123	-
0mm Bottom	0	2402	14.60	16.50	Full	0.223	0.345	-
0mm Bottom	39	2441	14.62	16.50	Full	0.268	0.413	C.1
0mm Bottom	78	2480	14.50	16.50	Full	0.248	0.393	-
Limit for General Population (Uncontrolled Exposure) 1.6 W/kg (1g)								

Bluetooth - EDR – 3-DH5 – SISO Core 1 (5 or 6 GHz WLAN OFF) (ePA):
Body Specific Absorption Rate (SAR) 1g Results

Test Position	Channel Number	Frequency (MHz)	Measured Average Power (dBm)	Tune Up (dBm)	SAR Scan Type	Measured 1g SAR (W/kg)	Scaled 1g SAR (W/kg)	Scan Figure Number
0mm Rear of Display	0	2402	15.10	16.50	Full	0.051	0.070	-
0mm Bottom	0	2402	15.10	16.50	Full	0.112	0.155	-
0mm Bottom	39	2441	14.55	16.50	Full	0.138	0.216	-
0mm Bottom	78	2480	14.59	16.50	Full	0.166	0.258	C.2
Limit for General Population (Uncontrolled Exposure) 1.6 W/kg (1g)								

Bluetooth - BDR – DH5 – SISO Core 2 (5 or 6 GHz WLAN OFF and ON) (iPA):
Body Specific Absorption Rate (SAR) 1g Results

Test Position	Channel Number	Frequency (MHz)	Measured Average Power (dBm)	Tune Up (dBm)	SAR Scan Type	Measured 1g SAR (W/kg)	Scaled 1g SAR (W/kg)	Scan Figure Number
0mm Rear of Display	78	2480	12.91	13.00	Full	0.033	0.034	-
0mm Bottom	0	2402	12.70	13.00	Full	0.082	0.088	-
0mm Bottom	39	2441	12.86	13.00	Full	0.098	0.101	C.3
0mm Bottom	78	2480	12.91	13.00	Full	0.092	0.094	-
Limit for General Population (Uncontrolled Exposure) 1.6 W/kg (1g)								



Bluetooth - EDR – 3-DH5 – SISO Core 0 (5 or 6 GHz WLAN ON) (ePA):
Body Specific Absorption Rate (SAR) 1g Results

Test Position	Channel Number	Frequency (MHz)	Measured Average Power (dBm)	Tune Up (dBm)	SAR Scan Type	Measured 1g SAR (W/kg)	Scaled 1g SAR (W/kg)	Scan Figure Number
0mm Rear of Display	39	2441	14.62	15.50	Full	0.080	0.098	-
0mm Bottom	0	2402	14.60	15.50	Full	0.223	0.274	-
0mm Bottom	39	2441	14.62	15.50	Full	0.268	0.328	C.1.
0mm Bottom	78	2480	14.50	15.50	Full	0.248	0.312	-
Limit for General Population (Uncontrolled Exposure) 1.6 W/kg (1g)								

Bluetooth - EDR – 3-DH5 – SISO Core 1 (5 or 6 GHz WLAN ON) (ePA):
Body Specific Absorption Rate (SAR) 1g Results

Test Position	Channel Number	Frequency (MHz)	Measured Average Power (dBm)	Tune Up (dBm)	SAR Scan Type	Measured 1g SAR (W/kg)	Scaled 1g SAR (W/kg)	Scan Figure Number
0mm Rear of Display	0	2402	15.10	15.50	Full	0.051	0.056	-
0mm Bottom	0	2402	15.10	15.50	Full	0.112	0.123	-
0mm Bottom	39	2441	14.55	15.50	Full	0.138	0.172	-
0mm Bottom	78	2480	14.59	15.50	Full	0.166	0.205	C.2
Limit for General Population (Uncontrolled Exposure) 1.6 W/kg (1g)								



Narrowband - UNII-1 – HDR8 – SISO Core 0 (2.4 GHz WLAN OFF) (ePA):
Body Specific Absorption Rate (SAR) 1g Results

Test Position	Channel Number	Frequency (MHz)	Measured Average Power (dBm)	Tune Up (dBm)	SAR Scan Type	Measured 1g SAR (W/kg)	Scaled 1g SAR (W/kg)	Scan Figure Number
0mm Rear of Display	Top	5250	12.20	12.50	Full	0.122	0.131	-
0mm Bottom	Bottom	5150	12.20	12.50	Full	0.262	0.281	-
0mm Bottom	Middle	5200	11.95	12.50	Full	0.347	0.394	-
0mm Bottom	Top	5250	12.20	12.50	Full	0.419	0.449	C.4
Limit for General Population (Uncontrolled Exposure) 1.6 W/kg (1g)								

Narrowband - UNII-1 – HDR8 – SISO Core 1 (2.4 GHz WLAN OFF) (ePA):
Body Specific Absorption Rate (SAR) 1g Results

Test Position	Channel Number	Frequency (MHz)	Measured Average Power (dBm)	Tune Up (dBm)	SAR Scan Type	Measured 1g SAR (W/kg)	Scaled 1g SAR (W/kg)	Scan Figure Number
0mm Rear of Display	Top	5250	13.02	13.50	Full	0.253	0.283	-
0mm Bottom	Bottom	5150	12.68	13.50	Full	0.468	0.565	-
0mm Bottom	Middle	5200	12.98	13.50	Full	0.558	0.629	-
0mm Bottom	Top	5250	13.02	13.50	Full	0.647	0.723	C.5
Limit for General Population (Uncontrolled Exposure) 1.6 W/kg (1g)								

Narrowband - UNII-3– HDR4 – SISO Core 0 (2.4 GHz WLAN OFF) (ePA):
Body Specific Absorption Rate (SAR) 1g Results

Test Position	Channel Number	Frequency (MHz)	Measured Average Power (dBm)	Tune Up (dBm)	SAR Scan Type	Measured 1g SAR (W/kg)	Scaled 1g SAR (W/kg)	Scan Figure Number
0mm Rear of Display	Top	5850	14.51	15.00	Full	0.267	0.299	-
0mm Bottom	Bottom	5725	14.55	15.00	Full	0.541	0.600	-
0mm Bottom	Middle	5788	14.53	15.00	Full	0.584	0.651	-
0mm Bottom	Top	5850	14.51	15.00	Full	0.659	0.738	C.6
Limit for General Population (Uncontrolled Exposure) 1.6 W/kg (1g)								



Narrowband - UNII-3– HDR4 – SISO Core 1 (2.4 GHz WLAN OFF) (ePA):
Body Specific Absorption Rate (SAR) 1g Results

Test Position	Channel Number	Frequency (MHz)	Measured Average Power (dBm)	Tune Up (dBm)	SAR Scan Type	Measured 1g SAR (W/kg)	Scaled 1g SAR (W/kg)	Scan Figure Number
0mm Rear of Display	Bottom	5725	13.28	14.50	Full	0.389	0.515	-
0mm Bottom	Bottom	5725	13.28	14.50	Full	0.812	1.075	C.7
0mm Bottom	Middle	5788	13.89	14.50	Full	0.844	0.971	-
0mm Bottom	Top	5850	13.39	14.50	Full	0.760	0.981	-
Limit for General Population (Uncontrolled Exposure) 1.6 W/kg (1g)								

Narrowband - UNII-1 – HDR8 – SISO Core 0 (2.4 GHz WLAN ON) (ePA):
Body Specific Absorption Rate (SAR) 1g Results

Test Position	Channel Number	Frequency (MHz)	Measured Average Power (dBm)	Tune Up (dBm)	SAR Scan Type	Measured 1g SAR (W/kg)	Scaled 1g SAR (W/kg)	Scan Figure Number
0mm Rear of Display	Top	5250	10.20	10.50	Full	0.068	0.073	-
0mm Bottom	Bottom	5150	10.38	10.50	Full	0.172	0.177	-
0mm Bottom	Middle	5200	10.22	10.50	Full	0.216	0.230	-
0mm Bottom	Top	5250	10.20	10.50	Full	0.259	0.278	C.8
Limit for General Population (Uncontrolled Exposure) 1.6 W/kg (1g)								

Narrowband - UNII-1 – HDR4 – SISO Core 1 (2.4 GHz WLAN ON) (ePA):
Body Specific Absorption Rate (SAR) 1g Results

Test Position	Channel Number	Frequency (MHz)	Measured Average Power (dBm)	Tune Up (dBm)	SAR Scan Type	Measured 1g SAR (W/kg)	Scaled 1g SAR (W/kg)	Scan Figure Number
0mm Rear of Display	Bottom	5150	11.50	10.00	Full	0.118	0.132	-
0mm Bottom	Bottom	5150	9.52	10.00	Full	0.205	0.229	-
0mm Bottom	Middle	5200	9.30	10.00	Full	0.229	0.269	-
0mm Bottom	Top	5250	9.50	10.00	Full	0.284	0.319	C.9
Limit for General Population (Uncontrolled Exposure) 1.6 W/kg (1g)								



Narrowband - UNII-3– HDR8 – SISO Core 0 (2.4 GHz WLAN ON) (ePA):
 Body Specific Absorption Rate (SAR) 1g Results

Test Position	Channel Number	Frequency (MHz)	Measured Average Power (dBm)	Tune Up (dBm)	SAR Scan Type	Measured 1g SAR (W/kg)	Scaled 1g SAR (W/kg)	Scan Figure Number
0mm Rear of Display	Top	5850	13.43	13.50	Full	0.193	0.196	-
0mm Bottom	Bottom	5725	12.95	13.50	Full	0.341	0.387	-
0mm Bottom	Middle	5788	12.92	13.50	Full	0.374	0.427	-
0mm Bottom	Top	5850	13.43	13.50	Full	0.472	0.480	C.10
Limit for General Population (Uncontrolled Exposure) 1.6 W/kg (1g)								

Narrowband - UNII-3– HDR4 – SISO Core 1 (2.4 GHz WLAN ON) (ePA):
 Body Specific Absorption Rate (SAR) 1g Results

Test Position	Channel Number	Frequency (MHz)	Measured Average Power (dBm)	Tune Up (dBm)	SAR Scan Type	Measured 1g SAR (W/kg)	Scaled 1g SAR (W/kg)	Scan Figure Number
0mm Rear of Display	Top	5850	9.83	10.00	Full	0.138	0.144	-
0mm Bottom	Bottom	5725	9.35	10.00	Full	0.298	0.346	C.11
0mm Bottom	Middle	5788	9.65	10.00	Full	0.302	0.327	-
0mm Bottom	Top	5850	9.83	10.00	Full	0.321	0.334	-
Limit for General Population (Uncontrolled Exposure) 1.6 W/kg (1g)								



Thread – SISO Core 0 (5 or 6 GHz OFF) (ePA):
Body Specific Absorption Rate (SAR) 1g Results

Test Position	Channel Number	Frequency (MHz)	Measured Average Power (dBm)	Tune Up (dBm)	SAR Scan Type	Measured 1g SAR (W/kg)	Scaled 1g SAR (W/kg)*	Scan Figure Number
0mm Rear of Display	26	2480	19.25	20.00	Full	0.148	0.107	-
0mm Bottom	11	2405	19.45	20.00	Full	0.477	0.328	-
0mm Bottom	18	2440	19.81	20.00	Full	0.540	0.342	-
0mm Bottom	26	2480	19.25	20.00	Full	0.552	0.398	C.12
Limit for General Population (Uncontrolled Exposure) 1.6 W/kg (1g)								
* Measured results for Thread RAT were scaled down from 100% duty cycle to 60.61%. Refer to Annex D								

Thread – SISO Core 1 (5 or 6 GHz OFF) (ePA):
Body Specific Absorption Rate (SAR) 1g Results

Test Position	Channel Number	Frequency (MHz)	Measured Average Power (dBm)	Tune Up (dBm)	SAR Scan Type	Measured 1g SAR (W/kg)	Scaled 1g SAR (W/kg)*	Scan Figure Number
0mm Rear of Display	26	2480	19.50	20.00	Full	0.127	0.086	-
0mm Bottom	11	2405	19.66	20.00	Full	0.276	0.181	-
0mm Bottom	18	2440	19.80	20.00	Full	0.373	0.237	-
0mm Bottom	26	2480	19.50	20.00	Full	0.457	0.311	C.13
Limit for General Population (Uncontrolled Exposure) 1.6 W/kg (1g)								
* Measured results for Thread RAT were scaled down from 100% duty cycle to 60.61%. Refer to Annex D								

Thread – SISO Core 2 (5 or 6 GHz OFF and ON) (iPA):
Body Specific Absorption Rate (SAR) 1g Results

Test Position	Channel Number	Frequency (MHz)	Measured Average Power (dBm)	Tune Up (dBm)	SAR Scan Type	Measured 1g SAR (W/kg)	Scaled 1g SAR (W/kg)*	Scan Figure Number
0mm Rear of Display	26	2480	12.25	12.50	Full	0.017	0.011	-
0mm Bottom	11	2405	12.20	12.50	Full	0.065	0.042	-
0mm Bottom	18	2440	12.25	12.50	Full	0.075	0.048	-
0mm Bottom	26	2480	12.25	12.50	Full	0.077	0.049	C.14
Limit for General Population (Uncontrolled Exposure) 1.6 W/kg (1g)								
* Measured results for Thread RAT were scaled down from 100% duty cycle to 60.61%. Refer to Annex D								



Thread – SISO Core 0 (5 or 6 GHz ON) (ePA):
Body Specific Absorption Rate (SAR) 1g Results

Test Position	Channel Number	Frequency (MHz)	Measured Average Power (dBm)	Tune Up (dBm)	SAR Scan Type	Measured 1g SAR (W/kg)	Scaled 1g SAR (W/kg)*	Scan Figure Number
0mm Rear of Display	18	2440	14.55	15.50	Full	0.078	0.059	-
0mm Bottom	11	2405	14.88	15.50	Full	0.273	0.191	-
0mm Bottom	18	2440	14.55	15.50	Full	0.291	0.220	C.15
0mm Bottom	26	2480	14.63	15.50	Full	0.285	0.211	-
Limit for General Population (Uncontrolled Exposure) 1.6 W/kg (1g)								
* Measured results for Thread RAT were scaled down from 100% duty cycle to 60.61%. Refer to Annex D								

Thread - SISO Core 1 (5 or 6 GHz ON) (ePA):
Body Specific Absorption Rate (SAR) 1g Results

Test Position	Channel Number	Frequency (MHz)	Measured Average Power (dBm)	Tune Up (dBm)	SAR Scan Type	Measured 1g SAR (W/kg)	Scaled 1g SAR (W/kg)*	Scan Figure Number
0mm Rear of Display	26	2480	15.38	15.50	Full	0.045	0.028	-
0mm Bottom	11	2405	14.91	15.50	Full	0.094	0.065	-
0mm Bottom	18	2440	14.62	15.50	Full	0.120	0.089	-
0mm Bottom	26	2480	15.38	15.50	Full	0.174	0.108	C.16
Limit for General Population (Uncontrolled Exposure) 1.6 W/kg (1g)								
* Measured results for Thread RAT were scaled down from 100% duty cycle to 60.61%. Refer to Annex D								



WLAN - 2450 MHz - 802.11g - 20 MHz - 1 Mbps - SISO Core 0:
Body Specific Absorption Rate (SAR) 1g Results

Test Position	Channel Number	Frequency (MHz)	Measured Average Power (dBm)	Tune Up (dBm)	SAR Scan Type	Measured 1g SAR (W/kg)	Scaled 1g SAR (W/kg)	Scan Figure Number
0mm Rear of Display	6	2437	19.00	19.25	Full	0.191	0.202	-
0mm Bottom	2	2417	18.69	19.25	Full	0.557	0.634	-
0mm Bottom	6	2437	19.00	19.25	Full	0.622	0.659	-
0mm Bottom	10	2457	18.76	19.25	Full	0.629	0.704	C.17
Limit for General Population (Uncontrolled Exposure) 1.6 W/kg (1g)								

WLAN - 2450 MHz - 802.11g - 20 MHz - 1 Mbps - SISO Core 1:
Body Specific Absorption Rate (SAR) 1g Results

Test Position	Channel Number	Frequency (MHz)	Measured Average Power (dBm)	Tune Up (dBm)	SAR Scan Type	Measured 1g SAR (W/kg)	Scaled 1g SAR (W/kg)	Scan Figure Number
0mm Rear of Display	2	2417	18.92	19.25	Full	0.123	0.133	-
0mm Bottom	2	2417	18.92	19.25	Full	0.382	0.412	-
0mm Bottom	6	2437	18.90	19.25	Full	0.463	0.502	-
0mm Bottom	10	2457	18.88	19.25	Full	0.489	0.532	C.18
Limit for General Population (Uncontrolled Exposure) 1.6 W/kg (1g)								



WLAN - 2450 MHz - 802.11n - HT20 - 2x2 MIMO Core 0 & Core 1:
Body Specific Absorption Rate (SAR) 1g Results

Test Position	Channel Number	Frequency (MHz)	Measured Average Power (dBm)	Tune Up (dBm)	SAR Scan Type	Measured 1g SAR (W/kg)	Scaled 1g SAR (W/kg)	Scan Figure Number
0mm Rear of Display (Core 0)	6	2437	18.76	19.25	Full	0.181	0.203	-
0mm Rear of Display (Core 1)	6	2437	18.58	19.25	Full	0.128	0.149	
0mm Bottom (Core 0)	2	2417	18.51	19.25	Full	0.629	0.746	-
0mm Bottom (Core 1)	2	2417	18.50	19.25	Full	0.394	0.468	
0mm Bottom (Core 0)	6	2437	18.76	19.25	Full	0.711	0.796	-
0mm Bottom (core 1)	6	2437	18.58	19.25	Full	0.481	0.561	
0mm Bottom (Core 0)	10	2457	18.38	19.25	Full	0.688	0.841	C.19
0mm Bottom (Core 1)	10	2457	18.28	19.25	Full	0.485	0.606	
Limit for General Population (Uncontrolled Exposure) 1.6 W/kg (1g)								

WLAN - U-NII-1/2A - 802.11ac - VHT80 - SISO Core 0
Body Specific Absorption Rate (SAR) 1g Results

Test Position	Channel Number	Frequency (MHz)	Measured Average Power (dBm)	Tune Up (dBm)	SAR Scan Type	Measured 1g SAR (W/kg)	Scaled 1g SAR (W/kg)	Scan Figure Number
0mm Rear of Display	42	5210	13.05	13.75	Full	0.155	0.182	-
0mm Bottom	42	5210	13.05	13.75	Full	0.517	0.607	-
0mm Bottom	58	5290	12.02	12.50	Full	0.572	0.639	C.20
Limit for General Population (Uncontrolled Exposure) 1.6 W/kg (1g)								

WLAN - U-NII-1/2A - 802.11ac - VHT160 - SISO Core 0
Body Specific Absorption Rate (SAR) 1g Results

Test Position	Channel Number	Frequency (MHz)	Measured Average Power (dBm)	Tune Up (dBm)	SAR Scan Type	Measured 1g SAR (W/kg)	Scaled 1g SAR (W/kg)	Scan Figure Number
0mm Bottom	50	5250	11.78	12.50	Full	0.445	0.525	-
Limit for General Population (Uncontrolled Exposure) 1.6 W/kg (1g)								



WLAN - U-NII-1/2A - 802.11ac - VHT80 - SISO Core 1
 Body Specific Absorption Rate (SAR) 1g Results

Test Position	Channel Number	Frequency (MHz)	Measured Average Power (dBm)	Tune Up (dBm)	SAR Scan Type	Measured 1g SAR (W/kg)	Scaled 1g SAR (W/kg)	Scan Figure Number
0mm Rear of Display	42	5210	13.07	13.50	Full	0.205	0.226	-
0mm Bottom	42	5210	13.07	13.50	Full	0.673	0.743	C.21
0mm Bottom	58	5290	12.65	13.00	Full	0.662	0.718	-
Limit for General Population (Uncontrolled Exposure) 1.6 W/kg (1g)								

WLAN - U-NII-1/2A - 802.11ac - VHT160 - SISO Core 1
 Body Specific Absorption Rate (SAR) 1g Results

Test Position	Channel Number	Frequency (MHz)	Measured Average Power (dBm)	Tune Up (dBm)	SAR Scan Type	Measured 1g SAR (W/kg)	Scaled 1g SAR (W/kg)	Scan Figure Number
0mm Bottom	50	5250	12.33	13.00	Full	0.613	0.715	-
Limit for General Population (Uncontrolled Exposure) 1.6 W/kg (1g)								

WLAN - U-NII-1/2A - 802.11ac - VHT80 - MCS0 - MIMO Core 0 & Core 1:
 Body Specific Absorption Rate (SAR) 1g Results

Test Position	Channel Number	Frequency (MHz)	Measured Average Power (dBm)	Tune Up (dBm)	SAR Scan Type	Measured 1g SAR (W/kg)	Scaled 1g SAR (W/kg)	Scan Figure Number
0mm Rear of Display (Core 0)	58	5290	12.42	12.50	Full	0.158	0.161	-
0mm Rear of Display (Core 1)	58	5290	12.07	12.50	Full	0.218	0.241	
0mm Bottom (Core 0)	42	5210	12.92	13.50	Full	0.703	0.803	C.22
0mm Bottom (Core 1)	42	5210	13.08	13.50	Full	0.764	0.842	
0mm Bottom (Core 0)	58	5290	12.42	12.50	Full	0.706	0.719	-
0mm Bottom (core 1)	58	5290	12.07	12.50	Full	0.707	0.781	
Limit for General Population (Uncontrolled Exposure) 1.6 W/kg (1g)								



WLAN - U-NII-2C - 802.11ac - VHT80 - SISO Core 0
 Body Specific Absorption Rate (SAR) 1g Results

Test Position	Channel Number	Frequency (MHz)	Measured Average Power (dBm)	Tune Up (dBm)	SAR Scan Type	Measured 1g SAR (W/kg)	Scaled 1g SAR (W/kg)	Scan Figure Number
0mm Rear of Display	106	5530	13.39	13.75	Full	0.196	0.213	-
0mm Bottom	106	5530	13.39	13.75	Full	0.719	0.781	C.23
0mm Bottom	122	5610	13.34	13.75	Full	0.563	0.619	-
0mm Bottom	138	5690	13.40	13.75	Full	0.570	0.618	-
Limit for General Population (Uncontrolled Exposure) 1.6 W/kg (1g)								

WLAN - U-NII-2C - 802.11ac - VHT80 - SISO Core 1
 Body Specific Absorption Rate (SAR) 1g Results

Test Position	Channel Number	Frequency (MHz)	Measured Average Power (dBm)	Tune Up (dBm)	SAR Scan Type	Measured 1g SAR (W/kg)	Scaled 1g SAR (W/kg)	Scan Figure Number
0mm Rear of Display	138	5690	12.50	12.75	Full	0.294	0.311	-
0mm Bottom	106	5530	12.14	12.75	Full	0.601	0.692	-
0mm Bottom	122	5610	12.38	12.75	Full	0.597	0.650	-
0mm Bottom	138	5690	12.50	12.75	Full	0.598	0.633	-
Limit for General Population (Uncontrolled Exposure) 1.6 W/kg (1g)								

WLAN - U-NII-2C - 802.11ac - VHT160 - SISO Core 1
 Body Specific Absorption Rate (SAR) 1g Results

Test Position	Channel Number	Frequency (MHz)	Measured Average Power (dBm)	Tune Up (dBm)	SAR Scan Type	Measured 1g SAR (W/kg)	Scaled 1g SAR (W/kg)	Scan Figure Number
0mm Bottom	114	5570	12.14	12.75	Full	0.601	0.692	C.24
Limit for General Population (Uncontrolled Exposure) 1.6 W/kg (1g)								



WLAN - U-NII-2C - 802.11ac - VHT80 - MCS0 - MIMO Core 0 & Core 1:
Body Specific Absorption Rate (SAR) 1g Results

Test Position	Channel Number	Frequency (MHz)	Measured Average Power (dBm)	Tune Up (dBm)	SAR Scan Type	Measured 1g SAR (W/kg)	Scaled 1g SAR (W/kg)	Scan Figure Number
0mm Rear of Display (Core 0)	122	5610	12.47	12.75	Full	0.163	0.174	-
0mm Rear of Display (Core 1)	122	5610	12.31	12.75	Full	0.303	0.335	
0mm Bottom (Core 0)	106	5530	11.95	12.75	Full	0.391	0.470	C.25
0mm Bottom (Core 1)	106	5530	12.07	12.75	Full	0.541	0.633	
0mm Bottom (Core 0)	122	5610	12.47	12.75	Full	0.382	0.407	-
0mm Bottom (Core 1)	122	5610	12.31	12.75	Full	0.564	0.624	
0mm Bottom (Core 0)	138	5690	12.32	12.75	Full	0.351	0.388	-
0mm Bottom (Core 1)	138	5690	12.21	12.75	Full	0.539	0.610	
Limit for General Population (Uncontrolled Exposure) 1.6 W/kg (1g)								

WLAN - U-NII-3 - 802.11ac - VHT80 - SISO Core 0
Body Specific Absorption Rate (SAR) 1g Results

Test Position	Channel Number	Frequency (MHz)	Measured Average Power (dBm)	Tune Up (dBm)	SAR Scan Type	Measured 1g SAR (W/kg)	Scaled 1g SAR (W/kg)	Scan Figure Number
0mm Rear of Display	155	5775	13.27	13.75	Full	0.246	0.275	-
0mm Bottom	155	5775	13.27	13.75	Full	0.588	0.657	C.26
Limit for General Population (Uncontrolled Exposure) 1.6 W/kg (1g)								



WLAN - U-NII-3 - 802.11ac - VHT80 - SISO Core 1
 Body Specific Absorption Rate (SAR) 1g Results

Test Position	Channel Number	Frequency (MHz)	Measured Average Power (dBm)	Tune Up (dBm)	SAR Scan Type	Measured 1g SAR (W/kg)	Scaled 1g SAR (W/kg)	Scan Figure Number
0mm Rear of Display	155	5775	12.53	13.25	Full	0.329	0.388	-
0mm Bottom	155	5775	12.53	13.25	Full	0.595	0.702	C.27
Limit for General Population (Uncontrolled Exposure) 1.6 W/kg (1g)								

WLAN - U-NII-3 – 802.11ac – VHT80 - MCS0 - MIMO Core 0 & Core 1:
 Body Specific Absorption Rate (SAR) 1g Results

Test Position	Channel Number	Frequency (MHz)	Measured Average Power (dBm)	Tune Up (dBm)	SAR Scan Type	Measured 1g SAR (W/kg)	Scaled 1g SAR (W/kg)	Scan Figure Number
0mm Rear of Display (Core 0)	155	5775	12.67	13.25	Full	0.314	0.359	-
0mm Rear of Display (Core 1)	155	5775	12.83	13.25	Full	0.201	0.221	
0mm Bottom (Core 0)	155	5775	12.67	13.25	Full	0.667	0.762	C.28
0mm Bottom (Core 1)	155	5775	12.83	13.25	Full	0.532	0.586	
Limit for General Population (Uncontrolled Exposure) 1.6 W/kg (1g)								



Specific Absorption Rate and Absorbed Power Density
 6 GHz - 802.11ax - HE160 - MCS0 - Core 0:
 Body Specific Absorption Rate (SAR) 1g and Absorbed Power Density (APD) 4cm² Results

Test Position	Channel Number	Frequency (MHz)	Measured Average Power (dBm)	Tune Up (dBm)	Measured 1g SAR (W/kg)	Scaled 1g SAR (W/kg)	Measured APD 4cm ² (W/m ²)	Scaled APD 4cm ² (W/m ²)	APD Exposure Ratio	Scan Figure Number
0mm Rear of Display	47	6185	12.50	12.50	0.164	0.164	1.240	1.240	0.062	-
0mm Bottom	15	6025	11.50	11.50	0.338	0.338	2.480	2.480	0.124	-
0mm Bottom	47	6185	12.50	12.50	0.399	0.399	2.940	2.940	0.147	C.29
0mm Bottom	79	6345	12.01	12.25	0.382	0.404	2.780	2.938	0.147	-
0mm Bottom	111	6505	10.07	10.25	0.300	0.313	2.160	2.251	0.113	-
0mm Bottom	143	6665	10.00	10.25	0.332	0.352	2.360	2.500	0.125	-
0mm Bottom	175	6825	9.94	10.25	0.310	0.333	2.180	2.341	0.117	-
0mm Bottom	207	6985	11.95	12.00	0.395	0.400	2.840	2.873	0.144	
Specific Absorption Rate limit for General Population (Uncontrolled Exposure) 1.6 W/kg (1g)										



Specific Absorption Rate and Absorbed Power Density
 6 GHz - 802.11ax - HE160 - MCS0 - Core 1:
 Body Specific Absorption Rate (SAR) 1g and Absorbed Power Density (APD) 4cm² Results

Test Position	Channel Number	Frequency (MHz)	Measured Average Power (dBm)	Tune Up (dBm)	Measured 1g SAR (W/kg)	Scaled 1g SAR (W/kg)	Measured APD 4cm ² (W/m ²)	Scaled APD 4cm ² (W/m ²)	APD Exposure Ratio	Scan Figure Number
0mm Rear of Display	47	6185	11.58	12.00	0.258	0.284	2.100	2.313	0.116	-
0mm Bottom	15	6025	11.24	11.25	0.419	0.420	3.420	3.428	0.171	-
0mm Bottom	47	6185	11.58	12.00	0.427	0.470	3.520	3.877	0.194	C.30
0mm Bottom	79	6345	11.74	12.00	0.329	0.349	2.780	2.952	0.148	-
0mm Bottom	111	6505	10.41	10.75	0.273	0.295	2.340	2.531	0.127	-
0mm Bottom	143	6665	10.67	10.75	0.278	0.283	2.320	2.363	0.118	-
0mm Bottom	175	6825	10.45	10.75	0.166	0.178	1.320	1.414	0.071	-
0mm Bottom	207	6985	12.20	13.00	0.211	0.254	1.640	1.972	0.099	-
Specific Absorption Rate limit for General Population (Uncontrolled Exposure) 1.6 W/kg (1g)										



Specific Absorption Rate and Absorbed Power Density
 6 GHz - 802.11ax - HE160 - MCS0 - Core 0-1 (MIMO):
 Body Specific Absorption Rate (SAR) 1g and Absorbed Power Density (APD) 4cm² Results

Test Position	Channel Number	Frequency (MHz)	Measured Average Power (dBm)	Tune Up (dBm)	Measured 1g SAR (W/kg)	Scaled 1g SAR (W/kg)	Measured APD 4cm ² (W/m ²)	Scaled APD 4cm ² (W/m ²)	APD Exposure Ratio	Scan Figure Number
0mm Rear Of Display (Core 0)	47	6185	10.23	12.00	0.113	0.170	0.760	1.142	0.057	-
0mm Rear Of Display (Core 1)	47	6185	10.17	12.00	0.183	0.279	1.560	2.378	0.119	
0mm Bottom (Core 0)	15	6025	11.00	11.25	0.430	0.455	3.400	3.601	0.180	-
0mm Bottom (Core 1)	15	6025	10.70	11.25	0.347	0.394	2.560	2.906	0.145	
0mm Bottom (Core 0)	47	6185	10.23	12.00	0.229	0.344	1.700	2.555	0.128	C.31
0mm Bottom (Core 1)	47	6185	10.17	12.00	0.318	0.485	2.600	3.963	0.198	
0mm Bottom (Core 0)	79	6345	11.70	12.00	0.358	0.384	2.660	2.850	0.143	-
0mm Bottom (Core 1)	79	6345	11.69	12.00	0.363	0.390	3.080	3.308	0.165	
0mm Bottom (Core 0)	111	6505	9.65	9.75	0.272	0.278	1.980	2.026	0.101	-
0mm Bottom (Core 1)	111	6505	9.48	9.75	0.248	0.264	1.980	2.107	0.105	
0mm Bottom (Core 0)	143	6665	9.60	10.25	0.274	0.318	1.940	2.253	0.113	-
0mm Bottom (Core 1)	143	6665	9.10	10.25	0.228	0.297	1.780	2.320	0.116	
0mm Bottom (Core 0)	175	6825	9.70	9.75	0.275	0.278	2.000	2.023	0.101	-
0mm Bottom (Core 1)	175	6825	9.50	9.75	0.128	0.136	1.060	1.123	0.056	
0mm Bottom (Core 0)	207	6985	10.99	11.25	0.346	0.367	2.340	2.484	0.124	-
0mm Bottom (Core 1)	207	6985	10.98	11.25	0.162	0.172	1.260	1.341	0.067	

Specific Absorption Rate limit for General Population (Uncontrolled Exposure) 1.6 W/kg (1g)

Incident Power Density (iPD) - 6000 MHz - 802.11ax - HE160 - MCS0 - Core 1

Test Position	Channel Number	Frequency (MHz)	Measured iPD 4cm ² (W/m ²)	Standalone iPD limit (W/m ²)	Exposure Ratio	Scan Figure Number
0mm Bottom	47	6185	6.14	10.00	0.614	C.32

The measured APD result of Core 1 was the highest value and was chosen for a iPD test.



1.3.3 Technical Description

The equipment under test (EUT) was a portable laptop computer.

1.3.4 Interim Procedures for FCC Radiofrequency Exposure Evaluations

The interim procedure for FCC radiofrequency (RF) exposure evaluations of U-NII 6–7 GHz band portable devices have been made available during the TCB workshop in October 2020. The procedure is summarized below:

- Evaluate SAR / APD with DASY Module SAR V16.0 or higher. The configurations to be tested are defined in the relevant Knowledge Database (KDB). The peak spatial averaged SAR (psSAR) and the peak spatial averaged absorbed Power Density (psAPD) are reported.
- For the configuration with the highest SAR / APD, evaluate the PD with DASY Module mmWave V3.0 or higher.

1.3.5 Test Configuration and Modes of Operation

The testing was performed with an integral battery supplied and manufactured by Apple Inc.

Supported technologies are Bluetooth (BDR/EDR//HDR/LE-1M/LE-M2), 2.4 GHz Thread, 5.0 GHz Narrowband (BDR/EDR//HDR), 2.4 GHz WLAN (802.11b/g/n/ax), 5.0 GHz WLAN (802.11a/n/ac/ax) and 6 GHz WLAN (802.11a/ax). 2x2 MIMO is supported for WLAN.

Bluetooth and Thread operates at lower power when the 5/6 GHz WLAN is enabled.

Narrowband operates at a lower power when the 2.4 GHz WLAN is enabled.

The report makes references to these (5/6 GHz WLAN ON/OFF) and (2.4 GHz WLAN ON/OFF) and similarly for Thread (5/6 GHz OFF/ON). Testing was performed with the Bluetooth, Thread, Narrowband and Wi-Fi transmitters working independently.

Testing was achieved using the device's internal software, scripts and settings supplied by the customer. For each scan, the device was configured into a continuous transmission test mode at a maximum power defined by the customer. Testing was performed in each position at the frequency that gave the highest output power for each band. Some SAR levels were found to be higher than the thresholds set in KDB 447498 D01 therefore additional testing was required at the relevant frequencies / channels of the bands.

Conducted power measurements were performed on a modified device (accessible conducted port) and the measured SAR results were power scaled to the maximum declared tune-up level. Power measurements were only performed for the test configurations, which were determined by the client.

For each antenna, the bottom surface, and the rear of the EUT display were assessed for SAR.

For the 5/6 GHz frequency bands the transmission mode used for testing was determined by the 802.11 configuration with the highest declared output power in each frequency band. Where multiple 802.11 configurations have the same specified output power, testing was performed using the mode with the largest channel bandwidth with the lowest order modulation and lowest data rate.



For SAR assessment, the relevant surfaces of the device were placed against an Elliptical phantom with a 0mm separation distance.

The Elliptical Flat Phantom dimensions are 600mm major axis and 400mm minor axis with a shell thickness of 2mm. The phantom was filled to a minimum depth of 150mm with the appropriate liquid. The dielectric properties were in accordance with the requirements specified in KDB 865665.

Included in this report are descriptions of the test method; the equipment used and an analysis of the test uncertainties applicable and diagrams indicating the locations of maximum SAR, APD and iPD for each relevant test position.

1.3.6 Antenna Location Diagram

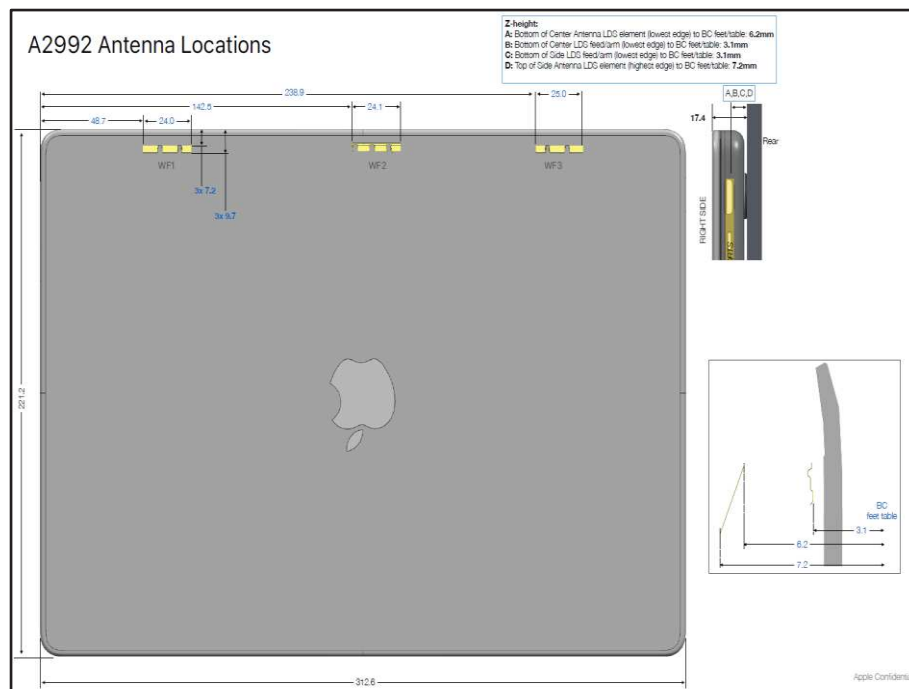

Figure 1

WF1(Core 1) – supports 2.4GHz/ 5GHz / BT-Thread-NB

WF2(Core 0) – supports 2.4GHz/ 5GHz / BT-Thread-NB

WF3(Core 2) – supports only 2.4GHz BT-Thread

1.3.7 Deviations from Standard

Initially, area scans were completed covering the whole of the bottom surface of the EUT to determine that there were no other RF radiators (unintentional) other than the antennas. The actual SAR measurements were completed using smaller area scans covering the antenna locations only.



1.4 POWER TABLES (TUNE UP VALUES)

Note: All values in dBm
NS= Not Supported

2.4 GHz Bluetooth (5.0 GHz WLAN off)

BT Core	PA	Channel	BDR	EDR	LE Data	HDR4	HDR8
0	iPA	All	13.00	9.50	7.50	6.00	6.00
0	ePA		13.00	16.50	15.00	15.00	13.00
1	iPA		13.00	9.50	7.50	6.00	6.00
1	ePA		13.00	16.50	15.00	15.00	13.00
2	iPA		13.00	9.50	7.50	6.00	6.00

2.4 GHz Bluetooth (5.0 GHz WLAN on)

BT Core	PA	Channel	BDR	EDR	LE Data	HDR4	HDR8
0	iPA	All	13.00	9.50	7.50	6.00	6.00
0	ePA		13.00	15.50	15.00	15.00	13.00
1	iPA		13.00	9.50	7.50	6.00	6.00
1	ePA		13.00	15.50	15.00	15.00	13.00
2	iPA		13.00	9.50	7.50	6.00	6.00

2.4 GHz Bluetooth (5.0 GHz WLAN off & on) - TXBF

BT Core	PA	Channel	BDR TXBF	EDR TXBF	LE TXBF	HDR4 TXBF	HDR8 TXBF
0	iPA	All	13.00	9.50	7.50	6.00	6.00
0	ePA		13.00	13.50	15.00	15.00	13.00
1	iPA		13.00	9.50	7.50	6.00	6.00
1	ePA		13.00	13.50	15.00	15.00	13.00
2	iPA		NS	NS	NS	NS	NS

5.0 GHz Narrowband UNII-1 - When 2.4 GHz WLAN OFF

NB Core	PA	Channel	BDR	HDR4	HDR8	BDR TXBF	HDR4 TXBF	HDR8 TXBF
0	iPA	All	7.50	4.50	4.50	2.50	4.50	4.50
0	ePA		NS	9.50	12.50	NS	4.50	7.50
1	iPA		10.00	4.50	4.50	2.50	4.50	4.50
1	ePA		NS	12.00	13.50	NS	4.50	7.50
2	iPA		NS	NS	NS	NS	NS	NS



5.0 GHz Narrowband UNII-1 - When 2.4 GHz WLAN ON

NB Core	PA	Channel	BDR	HDR4	HDR8	BDR TXBF	HDR4 TXBF	HDR8 TXBF
0	iPA	All	7.50	4.50	4.50	2.50	4.50	4.50
0	ePA		NS	9.50	10.50	NS	4.50	7.50
1	iPA		10.00	4.50	4.50	2.50	4.50	4.50
1	ePA		NS	10.00	10.00	NS	4.50	7.50
2	iPA		NS	NS	NS	NS	NS	NS

5.0 GHz Narrowband UNII-3 - When 2.4 GHz WLAN OFF

NB Core	PA	Channel	BDR	HDR4	HDR8	BDR TXBF	HDR4 TXBF	HDR8 TXBF
0	iPA	All	11.00	4.50	4.50	11.00	4.50	4.50
0	ePA		NS	15.00	13.50	NS	15.00	13.50
1	iPA		11.00	4.50	4.50	11.00	4.50	4.50
1	ePA		NS	14.50	13.50	NS	14.50	13.50
2	iPA		NS	NS	NS	NS	NS	NS

5.0 GHz Narrowband UNII-3 - When 2.4 GHz WLAN ON

NB Core	PA	Channel	BDR	HDR4	HDR8	BDR TXBF	HDR4 TXBF	HDR8 TXBF
0	iPA	All	10.50	4.50	4.50	10.50	4.50	4.50
0	ePA		NS	10.50	13.50	NS	10.50	10.50
1	iPA		10.00	4.50	4.50	10.00	4.50	4.50
1	ePA		NS	10.00	10.00	NS	10.00	10.00
2	iPA		NS	NS	NS	NS	NS	NS

5.0 GHz Narrowband UNII-5

NB Core	PA	Channel	BDR	HDR4	HDR8	BDR TXBF	HDR4 TXBF	HDR8 TXBF
0	iPA	All	NS	NS	NS	NS	NS	NS
0	ePA		NS	NS	NS	NS	NS	NS
1	iPA		NS	NS	NS	NS	NS	NS
1	ePA		NS	NS	NS	NS	NS	NS
2	iPA		NS	NS	NS	NS	NS	NS



2.4 GHz Thread – When 5.0 GHz OFF

Core	PA	Channel	Thread
0	iPA	All	13.00
0	ePA		20.00
1	iPA		13.00
1	ePA		20.00
2	iPA		12.50

2.4 GHz Thread – When 5.0 GHz ON

Core	PA	Channel	Thread
0	iPA	All	13.00
0	ePA		15.50
1	iPA		13.00
1	ePA		15.50
2	iPA		12.50



2.4 GHz WLAN SISO Core 0 & Core 1

Channel	Centre Frequency (MHz)	b (SISO)	g (SISO) Low Rate	11n/11ac HT20 (SISO) Low Rate	11ax HE20 (SISO) Low Rate	11ax HE20 RU106 (SISO)	11ax HE20 RU52 (SISO)	11ax HE20 RU26 (SISO)
1	2412	19.00	18.00	17.00	16.00	17.25	17.50	14.50
2	2417	19.00	19.25	19.25	19.25	17.25	17.50	14.50
3	2422	19.00	19.25	19.25	19.25	18.75	17.50	14.50
4	2427	19.00	19.25	19.25	19.25	19.25	17.50	14.50
5	2432	19.00	19.25	19.25	19.25	19.25	17.50	14.50
6	2437	19.00	19.25	19.25	19.25	19.25	17.50	14.50
7	2442	19.00	19.25	19.25	19.25	19.25	17.50	14.50
8	2447	19.00	19.25	19.25	19.25	19.25	17.50	14.50
9	2452	19.00	19.25	19.25	19.25	19.25	17.50	14.50
10	2457	19.00	19.25	19.25	19.25	17.50	17.50	14.50
11	2462	19.00	18.75	18.50	16.75	17.00	17.50	14.50
12	2467	17.25	15.75	15.25	14.25	14.50	17.50	14.50
13	2472	15.50	7.00	6.25	6.25	-1.00	-2.00	-5.00

2.4 GHz WLAN MIMO Core 0 & Core 1

Channel	Centre Frequency (MHz)	b (2Tx, DSSS)	11n/11ac HT20 (2Tx, nonTXBF)	11ax HE20 (2Tx, nonTXBF)	11ax HE20 RU106 (2Tx, nonTXBF)	11ax HE20 RU52 (2Tx, nonTXBF)	11ax HE20 RU26 (2Tx, nonTXBF)	11n/11ac HT20 (2Tx, TXBF) Low Rate
1	2412	NS	15.50	14.25	15.50	17.50	14.50	NS
2	2417	NS	19.25	18.00	16.25	17.50	14.50	NS
3	2422	NS	19.25	19.25	18.75	17.50	14.50	NS
4	2427	NS	19.25	19.25	19.25	17.50	14.50	NS
5	2432	NS	19.25	19.25	19.25	17.50	14.50	NS
6	2437	NS	19.25	19.25	19.25	17.50	14.50	NS
7	2442	NS	19.25	19.25	19.25	17.50	14.50	NS
8	2447	NS	19.25	19.25	19.25	17.50	14.50	NS
9	2452	NS	19.25	19.25	19.25	17.50	14.50	NS
10	2457	NS	19.25	18.75	17.50	17.50	14.50	NS
11	2462	NS	17.00	15.00	17.50	17.50	14.50	NS
12	2467	NS	14.00	12.50	14.50	16.75	14.50	NS
13	2472	NS	6.00	6.00	-5.00	-8.00	-8.50	NS



5.0 GHz WLAN - 20 MHz BW – SISO Core 0

Channel	Centre Frequency (MHz)	a (SISO) Low Rate	11n/11ac HT20 (SISO) Low Rate	11ax HE20 (SISO) Low Rate	11ax HE20 RU106 (SISO)	11ax HE20 RU52 (SISO)	11ax HE20 RU26 (SISO)
36	5180	13.75	13.75	13.75	13.75	12.00	9.00
40	5200	13.75	13.75	13.75	13.75	12.00	9.00
44	5220	13.75	13.75	13.75	13.75	12.00	9.00
48	5240	13.75	13.75	13.75	13.75	12.00	9.00
52	5260	12.50	12.50	12.50	12.50	11.25	NS
56	5280	12.50	12.50	12.50	12.50	11.25	NS
60	5300	12.50	12.50	12.50	12.50	11.25	NS
64	5320	12.50	12.50	12.50	12.50	11.25	NS
100	5500	13.75	13.75	13.75	13.75	13.75	NS
104	5520	13.75	13.75	13.75	13.75	13.75	NS
108	5540	13.75	13.75	13.75	13.75	13.75	NS
112	5560	13.75	13.75	13.75	13.75	13.75	NS
116	5580	13.75	13.75	13.75	13.75	13.75	NS
120	5600	13.75	13.75	13.75	13.75	13.75	NS
124	5620	13.75	13.75	13.75	13.75	13.75	NS
128	5640	13.75	13.75	13.75	13.75	13.75	NS
132	5660	13.75	13.75	13.75	13.75	13.75	NS
136	5680	13.75	13.75	13.75	13.75	13.75	NS
140	5700	13.75	13.75	13.75	13.75	9.00	NS
144	5720	13.75	13.75	13.75	13.75	13.75	NS
149	5745	13.75	13.75	13.75	13.75	13.75	13.50
153	5765	13.75	13.75	13.75	13.75	13.75	13.50
157	5785	13.75	13.75	13.75	13.75	13.75	13.50
161	5805	13.75	13.75	13.75	13.75	13.75	13.50
165	5825	13.75	13.75	13.75	13.75	13.75	13.50



5.0 GHz WLAN - 20 MHz BW – SISO Core 1

Channel	Centre Frequency (MHz)	a (SISO) Low Rate	11n/11ac HT20 (SISO) Low Rate	11ax HE20 (SISO) Low Rate	11ax HE20 RU106 (SISO)	11ax HE20 RU52 (SISO)	11ax HE20 RU26 (SISO)
36	5180	13.50	13.50	13.50	13.50	12.00	9.00
40	5200	13.50	13.50	13.50	13.50	12.00	9.00
44	5220	13.50	13.50	13.50	13.50	12.00	9.00
48	5240	13.50	13.50	13.50	13.50	12.00	9.00
52	5260	13.00	13.00	13.00	13.00	11.25	NS
56	5280	13.00	13.00	13.00	13.00	11.25	NS
60	5300	13.00	13.00	13.00	13.00	11.25	NS
64	5320	13.00	13.00	13.00	13.00	11.25	NS
100	5500	12.75	12.75	12.75	12.75	12.75	NS
104	5520	12.75	12.75	12.75	12.75	12.75	NS
108	5540	12.75	12.75	12.75	12.75	12.75	NS
112	5560	12.75	12.75	12.75	12.75	12.75	NS
116	5580	12.75	12.75	12.75	12.75	12.75	NS
120	5600	12.75	12.75	12.75	12.75	12.75	NS
124	5620	12.75	12.75	12.75	12.75	12.75	NS
128	5640	12.75	12.75	12.75	12.75	12.75	NS
132	5660	12.75	12.75	12.75	12.75	12.75	NS
136	5680	12.75	12.75	12.75	12.75	12.75	NS
140	5700	12.75	12.75	12.75	12.75	9.00	NS
144	5720	12.75	12.75	12.75	12.75	12.75	NS
149	5745	13.25	13.25	13.25	13.25	13.25	13.25
153	5765	13.25	13.25	13.25	13.25	13.25	13.25
157	5785	13.25	13.25	13.25	13.25	13.25	13.25
161	5805	13.25	13.25	13.25	13.25	13.25	13.25
165	5825	13.25	13.25	13.25	13.25	13.25	13.25



5.0 GHz WLAN - 20 MHz BW - MIMO Core 0 & Core 1 CDD

Channel	Centre Frequency (MHz)	11n/11ac HT20 (2Tx, CDD, nonTXBF) Low Rate	11ax HE20 (2Tx, CDD, nonTxBF)	11ax HE20 RU106 (2Tx, CDD, nonTxBF)	11ax HE20 RU52 (2Tx, CDD, nonTxBF)	11ax HE20 RU26 (2Tx, CDD, nonTxBF)
36	5180	12.25	12.25	10.25	7.25	4.25
40	5200	12.25	12.25	10.25	7.25	4.25
44	5220	12.25	12.25	10.25	7.25	4.25
48	5240	12.25	12.25	10.25	7.25	4.25
52	5260	11.75	11.75	9.75	6.75	NS
56	5280	11.75	11.75	9.75	6.75	NS
60	5300	11.75	11.75	9.75	6.75	NS
64	5320	11.75	11.75	9.75	6.75	NS
100	5500	12.75	12.75	12.75	9.75	NS
104	5520	12.75	12.75	12.75	9.75	NS
108	5540	12.75	12.75	12.75	9.75	NS
112	5560	12.75	12.75	12.75	9.75	NS
116	5580	12.75	12.75	12.75	9.75	NS
120	5600	12.75	12.75	12.75	9.75	NS
124	5620	12.75	12.75	12.75	9.75	NS
128	5640	12.75	12.75	12.75	9.75	NS
132	5660	12.75	12.75	12.75	9.75	NS
136	5680	12.75	12.75	12.75	9.75	NS
140	5700	12.75	12.75	12.75	9.00	NS
144	5720	12.75	12.75	12.75	9.75	NS
149	5745	13.25	13.25	13.25	13.25	13.25
153	5765	13.25	13.25	13.25	13.25	13.25
157	5785	13.25	13.25	13.25	13.25	13.25
161	5805	13.25	13.25	13.25	13.25	13.25
165	5825	13.25	13.25	13.25	13.25	13.25



5.0 GHz WLAN - 20 MHz BW - MIMO Core 0 & Core 1 SDM

Channel	Centre Frequency (MHz)	11n/11ac HT20 (2Tx, SDM, nonTxBF) Low Rate	11ax HE20 (2Tx, SDM, nonTxBF) Low Rate	11ax HE20 RU106 (2Tx, SDM, nonTxBF)	11ax HE20 RU52 (2Tx, SDM, nonTxBF)	11ax HE20 RU26 (2Tx, SDM, nonTxBF)	11n/11ac VHT20 (2Tx, TxBF) Low Rate
36	5180	13.50	13.50	13.25	10.25	7.25	12.25
40	5200	13.50	13.50	13.25	10.25	7.25	12.25
44	5220	13.50	13.50	13.25	10.25	7.25	12.25
48	5240	13.50	13.50	13.25	10.25	7.25	12.25
52	5260	12.50	12.50	12.50	9.50	NS	11.75
56	5280	12.50	12.50	12.50	9.50	NS	11.75
60	5300	12.50	12.50	12.50	9.50	NS	11.75
64	5320	12.50	12.50	12.50	9.50	NS	11.75
100	5500	12.75	12.75	12.75	11.50	NS	12.75
104	5520	12.75	12.75	12.75	11.50	NS	12.75
108	5540	12.75	12.75	12.75	11.50	NS	12.75
112	5560	12.75	12.75	12.75	11.50	NS	12.75
116	5580	12.75	12.75	12.75	11.50	NS	12.75
120	5600	12.75	12.75	12.75	11.50	NS	12.75
124	5620	12.75	12.75	12.75	11.50	NS	12.75
128	5640	12.75	12.75	12.75	11.50	NS	12.75
132	5660	12.75	12.75	12.75	11.50	NS	12.75
136	5680	12.75	12.75	12.75	11.50	NS	12.75
140	5700	12.75	12.75	12.75	9.00	NS	12.75
144	5720	12.75	12.75	12.75	11.50	NS	12.75
149	5745	13.25	13.25	13.25	13.25	13.25	13.25
153	5765	13.25	13.25	13.25	13.25	13.25	13.25
157	5785	13.25	13.25	13.25	13.25	13.25	13.25
161	5805	13.25	13.25	13.25	13.25	13.25	13.25
165	5825	13.25	13.25	13.25	13.25	13.25	13.25



5.0 GHz WLAN - 40 MHz - SISO Core 0

Channel	Centre Frequency (MHz)	11n/11ac HT40 (SISO) Low Rate	11ax HE40 (SISO) Low Rate	11ax HE40 RU106 (SISO)	11ax HE40 RU52 (SISO)	11ax HE40 RU26 (SISO)
38	5190	13.75	13.75	13.75	12.00	9.00
46	5230	13.75	13.75	13.75	12.00	9.00
54	5270	12.50	12.50	12.50	11.25	NS
62	5310	12.50	12.50	12.50	10.00	NS
102	5510	13.75	13.75	13.75	13.50	NS
110	5550	13.75	13.75	13.75	13.50	NS
118	5590	13.75	13.75	13.75	13.50	NS
126	5630	13.75	13.75	13.75	13.50	NS
134	5670	13.75	13.75	13.75	13.50	NS
142	5710	13.75	13.75	13.75	13.50	NS
151	5755	13.75	13.75	13.75	13.50	10.50
159	5795	13.75	13.75	13.75	13.50	10.50

5.0 GHz WLAN - 40 MHz - SISO Core 1

Channel	Centre Frequency (MHz)	11n/11ac HT40 (SISO) Low Rate	11ax HE40 (SISO) Low Rate	11ax HE40 RU106 (SISO)	11ax HE40 RU52 (SISO)	11ax HE40 RU26 (SISO)
38	5190	13.50	13.50	13.50	12.00	9.00
46	5230	13.50	13.50	13.50	12.00	9.00
54	5270	13.00	13.00	13.00	11.25	NS
62	5310	13.00	13.00	13.00	10.00	NS
102	5510	12.75	12.75	12.75	12.75	NS
110	5550	12.75	12.75	12.75	12.75	NS
118	5590	12.75	12.75	12.75	12.75	NS
126	5630	12.75	12.75	12.75	12.75	NS
134	5670	12.75	12.75	12.75	12.75	NS
142	5710	12.75	12.75	12.75	12.75	NS
151	5755	13.25	13.25	13.25	13.25	10.50
159	5795	13.25	13.25	13.25	13.25	10.50



5.0 GHz WLAN - 40 MHz - MIMO Core 0 & Core 1 CDD

Channel	11n/11ac HT40 (2Tx, CDD, nonTxBF) Low Rate	11ax HE40 (2Tx, CDD, nonTxBF) Low Rate	11ax HE40 RU106 (2Tx, CDD, nonTxBF)	11ax HE40 RU52 (2Tx, CDD, nonTxBF)	11ax HE40 RU26 (2Tx, CDD, nonTxBF)
38	14.00	14.00	11.75	8.75	5.75
46	14.00	14.00	11.75	8.75	5.75
54	13.25	13.25	10.25	7.25	NS
62	13.25	13.25	10.00	7.00	NS
102	13.25	13.25	12.00	9.00	NS
110	13.25	13.25	12.00	9.00	NS
118	13.25	13.25	12.25	9.25	NS
126	13.25	13.25	12.25	9.25	NS
134	13.25	13.25	12.00	9.00	NS
142	13.25	13.25	12.25	9.25	NS
151	13.75	13.75	13.75	13.50	10.50
159	13.75	13.75	13.75	13.50	10.50

5.0 GHz WLAN - 40 MHz - MIMO Core 0 & Core 1 SDM

Channel	11n/11ac HT40 (2Tx, SDM, nonTxBF) Low Rate	11ax HE40 (2Tx, SDM, nonTxBF) Low Rate	11ax HE40 RU106 (2Tx, SDM, nonTxBF)	11ax HE40 RU52 (2Tx, SDM, nonTxBF)	11ax HE40 RU26 (2Tx, SDM, nonTxBF)	11n/11ac VHT40 (2Tx, TxBF) Low Rate
38	14.00	13.50	13.50	12.00	10.25	7.25
46	14.00	13.50	13.50	13.25	10.25	7.25
54	13.25	12.50	12.50	12.50	9.50	NS
62	13.00	12.50	12.50	10.00	7.00	NS
102	13.25	12.75	12.75	12.75	11.00	NS
110	13.25	12.75	12.75	12.75	11.50	NS
118	13.25	12.75	12.75	12.75	11.50	NS
126	13.25	12.75	12.75	12.75	11.50	NS
134	13.25	12.75	12.75	12.75	11.50	NS
142	13.25	12.75	12.75	12.75	11.50	NS
151	13.75	13.25	13.25	13.25	13.25	10.50
159	13.75	13.25	13.25	13.25	13.25	10.50



5.0 GHz WLAN - 80 MHz - SISO Core 0

Channel	Centre Frequency (MHz)	11ac VHT80 (SISO) Low Rate	11ax HE80 (SISO) Low Rate	11ax HE80 RU106 (SISO)	11ax HE80 RU52 (SISO)	11ax HE80 RU26 (SISO)
42	5210	13.75	13.75	13.50	10.50	7.50
58	5290	12.50	12.50	12.00	10.00	NS
106	5530	13.75	13.75	12.75	10.00	NS
122	5610	13.75	13.75	13.50	10.50	NS
138	5690	13.75	13.75	13.50	10.50	NS
155	5775	13.75	13.75	13.50	10.50	7.50

5.0 GHz WLAN - 80 MHz - SISO Core 1

Channel	11ac VHT80 (SISO) Low Rate	11ax HE80 (SISO) Low Rate	11ax HE80 RU106 (SISO)	11ax HE80 RU52 (SISO)	11ax HE80 RU26 (SISO)	11ac VHT80 (SISO) Low Rate
42	5210	13.50	13.50	13.50	10.50	7.50
58	5290	13.00	13.00	12.00	10.00	NS
106	5530	12.75	12.75	12.75	10.00	NS
122	5610	12.75	12.75	12.75	10.50	NS
138	5690	12.75	12.75	12.75	10.50	NS
155	5775	13.25	13.25	13.25	10.50	7.50

5.0 GHz WLAN - 80 MHz - MIMO Core 0 & Core 1 CDD

Channel	Centre Frequency (MHz)	11ac VHT80 (2Tx, CDD, nonTxBF) Low Rate	11ax HE80 (2Tx, CDD, nonTxBF) Low Rate	11ax HE80 RU106 (2Tx, CDD, nonTxBF)	11ax HE80 RU52 (2Tx, CDD, nonTxBF)	11ax HE80 RU26 (2Tx, CDD, nonTxBF)
42	5210	13.50	13.50	10.25	7.25	4.25
58	5290	12.50	12.50	9.00	6.75	NS
106	5530	12.75	12.75	10.00	6.00	NS
122	5610	12.75	12.75	12.75	9.75	NS
138	5690	12.75	12.75	12.75	9.75	NS
155	5775	13.25	13.25	13.25	10.50	7.50



5.0 GHz WLAN - 80 MHz - MIMO Core 0 & Core 1 SDM

Channel	Centre Frequency (MHz)	11ac VHT80 (2Tx, SDM, nonTxBF) Low Rate	11ax HE80 (2Tx, SDM, nonTxBF) Low Rate	11ax HE80 RU106 (2Tx, SDM, nonTxBF)	11ax HE80 RU52 (2Tx, SDM, nonTxBF)	11ax HE80 RU26 (2Tx, SDM, nonTxBF)	11ac VHT80 (2Tx, TxBF) Low Rate
42	5210	13.50	13.50	11.50	8.00	6.00	13.50
58	5290	12.50	12.50	9.00	7.50	NS	11.50
106	5530	12.75	12.75	10.00	6.00	NS	12.75
122	5610	12.75	12.75	12.75	10.50	NS	12.75
138	5690	12.75	12.75	12.75	10.50	NS	12.75
155	5775	13.25	13.25	13.25	10.50	7.50	13.25

5.0 GHz WLAN - 160 MHz - SISO Core 0

Channel	Centre Frequency (MHz)	11ac VHT160 (SISO) Low Rate	11ax HE160 (SISO) Low Rate	11ax HE160 RU106 (SISO)	11ax HE160 RU52 (SISO)	11ax HE160 RU26 (SISO)
50	5250	12.50	12.50	10.50	7.50	NS
114	5570	13.00	13.00	10.50	7.50	NS

5.0 GHz WLAN - 160 MHz - SISO Core 1

Channel	Centre Frequency (MHz)	11ac VHT160 (SISO) Low Rate	11ax HE160 (SISO) Low Rate	11ax HE160 RU106 (SISO)	11ax HE160 RU52 (SISO)	11ax HE160 RU26 (SISO)
50	5250	13.00	13.00	10.50	7.50	NS
114	5570	12.75	12.75	10.50	7.50	NS

5.0 GHz WLAN - 160 MHz - MIMO Core 0 & Core 1 CDD

Channel	Centre Frequency (MHz)	11ac VHT160 (2Tx, CDD, nonTxBF) Low Rate	11ax HE160 (2Tx, CDD, nonTxBF) Low Rate	11ax HE160 RU106 (2Tx, CDD, nonTxBF)	11ax HE160 RU52 (2Tx, CDD, nonTxBF)	11ax HE160 RU26 (2Tx, CDD, nonTxBF)
50	5250	10.25	10.25	9.75	6.75	NS
114	5570	9.50	10.00	10.00	6.00	NS

5.0 GHz WLAN - 160 MHz - MIMO Core 0 & Core 1 SDM

Channel	Centre Frequency (MHz)	11ac VHT160 (2Tx, SDM, nonTxBF) Low Rate	11ax HE160 (2Tx, SDM, nonTxBF) Low Rate	11ax HE160 RU106 (2Tx, SDM, nonTxBF)	11ax HE160 RU52 (2Tx, SDM, nonTxBF)	11ax HE160 RU26 (2Tx, SDM, nonTxBF)	11ac VHT160 (2Tx, TxBF) Low Rate
50	5250	10.25	10.25	10.00	7.50	NS	NS
114	5570	9.50	10.00	10.00	6.00	NS	NS



6 GHz WLAN - 20 MHz - SISO Core 0 & Core 1

Channel	Centre Frequency (MHz)	a (SISO) Low Rate	11ax HE20 (SISO) Low Rate	11ax HE20 RU106 (SISO)	11ax HE20 RU52 (SISO)	11ax HE20 RU26 (SISO)
2	5935	NS	NS	NS	NS	NS
1	5955	3.25	3.25	0.25	-3.00	-6.00
5	5975	3.25	3.25	0.25	-3.00	-6.00
9-29	5945	3.25	3.25	0.25	-3.00	-6.00
33-61	6185	4.50	4.50	1.50	-1.50	-4.50
65-85	6325	3.75	3.75	0.75	-2.50	-5.50
89	6395	3.75	3.75	0.75	-2.50	-5.50
93	6415	3.75	3.75	0.75	-2.50	-5.50
97-113	6475	4.00	4.00	1.00	-2.00	-5.00
117-181	6695	3.75	3.75	0.75	-2.50	-5.50
185	6875	3.75	3.75	0.75	-2.50	-5.50
189-225	6985	4.50	4.50	1.50	-1.50	-4.50
229	7095	4.50	4.50	1.50	-1.50	-4.50
233	7115	3.00	NS	NS	NS	NS

6 GHz WLAN - 20 MHz - MIMO Core 0 & Core 1 CDD

Channel	Centre Frequency (MHz)	11ax HE20 (2Tx, CDD, nonTxBF) Low Rate	11ax HE20 RU106 (2Tx, CDD, nonTxBF)	11ax HE20 RU52 (2Tx, CDD, nonTxBF)	11ax HE20 RU26 (2Tx, CDD, nonTxBF)
2	5935	NS	NS	NS	NS
1	5955	-2.50	-5.50	-8.50	NS
5	5975	-2.50	-5.50	-8.50	NS
9-29	5945	-2.50	-5.50	-8.50	NS
33-61	6185	-1.00	-4.00	-7.00	NS
65-85	6325	-1.00	-4.00	-7.00	NS
89	6395	-1.00	-4.00	-7.00	NS
93	6415	-1.00	-4.00	-7.00	NS
97-113	6475	-1.00	-4.00	-7.00	NS
117-181	6695	-2.00	-5.00	-8.00	NS
185	6875	-2.00	-5.00	-8.00	NS
189-225	6985	-0.50	-3.50	-6.50	NS
229	7095	-0.50	-3.50	-6.50	NS
233	7115	NS	NS	NS	NS



6 GHz WLAN - 20 MHz - MIMO Core 0 & Core 1 SDM

Channel	Centre Frequency (MHz)	11ax HE20 (2Tx, CDD, nonTxBF) Low Rate	11ax HE20 RU106 (2Tx, CDD, nonTxBF)	11ax HE20 RU52 (2Tx, CDD, nonTxBF)	11ax HE20 RU26 (2Tx, CDD, nonTxBF)	11ax HE20 (2Tx, TxBF) Low Rate
2	5935	NS	NS	NS	NS	NS
1	5955	0.75	-2.50	-5.50	-8.50	NS
5	5975	0.75	-2.50	-5.50	-8.50	NS
9-29	5945	0.75	-2.50	-5.50	-8.50	NS
33-61	6185	2.00	-1.00	-4.00	-7.00	NS
65-85	6325	1.75	-1.50	-4.50	-7.50	NS
89	6395	1.75	-1.50	-4.50	-7.50	NS
93	6415	1.75	-1.50	-4.50	-7.50	NS
97-113	6475	2.00	-1.00	-4.00	-7.00	NS
117-181	6695	1.25	-2.00	-5.00	-8.00	NS
185	6875	1.25	-2.00	-5.00	-8.00	NS
189-225	6985	2.75	-0.50	-3.50	-6.50	NS
229	7095	2.75	-0.50	-3.50	-6.50	NS
233	7115	NS	NS	NS	NS	NS

6 GHz WLAN - 40 MHz - SISO Core 0 & Core 1

Channel	Centre Frequency (MHz)	11ax HE40 (SISO) Low Rate	11ax HE40 RU106 (SISO)	11ax HE40 RU52 (SISO)	11ax HE40 RU26 (SISO)
3	5965	5.75	0.25	-3.00	-6.00
11	6005	5.75	0.25	-3.00	-6.00
19-27	6065	5.75	0.25	-3.00	-6.00
35-59	6185	7.00	1.50	-1.50	-4.50
67-75	6305	6.25	0.75	-2.50	-5.50
83	6365	6.25	0.75	-2.50	-5.50
91	6405	6.25	0.75	-2.50	-5.50
99-107	6465	6.50	1.00	-2.00	-5.00
115	6525	6.25	0.75	-2.50	-5.50
123-179	6705	6.25	0.75	-2.50	-5.50
187	6885	6.25	0.75	-2.50	-5.50
195-219	6985	7.00	1.50	-1.50	-4.50
227	7085	7.00	1.50	-1.50	-4.50



6 GHz WLAN - 40 MHz - MIMO Core 0 & Core 1 CDD

Channel	Centre Frequency (MHz)	11ax HE40 (2Tx, CDD, nonTxBF) Low Rate	11ax HE40 RU106 (2Tx, CDD, nonTxBF)	11ax HE40 RU52 (2Tx, CDD, nonTxBF)	11ax HE40 RU26 (2Tx, CDD, nonTxBF)
3	5965	0.25	-5.50	-8.50	NS
11	6005	0.25	-5.50	-8.50	NS
19-27	6065	0.25	-5.50	-8.50	NS
35-59	6185	1.50	-4.00	-7.00	NS
67-75	6305	1.50	-4.00	-7.00	NS
83	6365	1.50	-4.00	-7.00	NS
91	6405	1.50	-4.00	-7.00	NS
99-107	6465	1.50	-4.00	-7.00	NS
115	6525	0.75	-5.00	-8.00	NS
123-179	6705	0.75	-5.00	-8.00	NS
187	6885	0.75	-5.00	-8.00	NS
195-219	6985	2.25	-3.50	-6.50	NS
227	7085	2.25	-3.50	-6.50	NS

6 GHz WLAN - 40 MHz - MIMO Core 0 & Core 1 SDM

Channel	Centre Frequency (MHz)	11ax HE40 (2Tx, CDD, nonTxBF) Low Rate	11ax HE40 RU106 (2Tx, CDD, nonTxBF)	11ax HE40 RU52 (2Tx, CDD, nonTxBF)	11ax HE40 RU26 (2Tx, CDD, nonTxBF)	11ax HE40 (2Tx, TxBF) Low Rate
3	5965	3.25	-2.50	-5.50	-8.50	NS
11	6005	3.25	-2.50	-5.50	-8.50	NS
19-27	6065	3.25	-2.50	-5.50	-8.50	NS
35-59	6185	4.50	-1.00	-4.00	-7.00	1.50
67-75	6305	4.25	-1.50	-4.50	-7.50	1.50
83	6365	4.25	-1.50	-4.50	-7.50	1.50
91	6405	4.25	-1.50	-4.50	-7.50	1.50
99-107	6465	4.50	-1.00	-4.00	-7.00	1.50
115	6525	3.75	-2.00	-5.00	-8.00	NS
123-179	6705	3.75	-2.00	-5.00	-8.00	NS
187	6885	3.75	-2.00	-5.00	-8.00	NS
195-219	6985	5.25	-0.50	-3.50	-6.50	2.25
227	7085	5.25	-0.50	-3.50	-6.50	2.25



6 GHz WLAN - 80 MHz - SISO Core 0 & Core 1

Channel	Centre Frequency (MHz)	11ax HE80 (SISO) Low Rate	11ax HE80 RU106 (SISO)	11ax HE80 RU52 (SISO)	11ax HE80 RU26 (SISO)
7	5985	8.75	0.25	-3.00	-6.00
23	6065	8.75	0.25	-3.00	-6.00
39-55	6185	10.00	1.50	-1.50	-4.50
71	6305	9.25	0.75	-2.50	-5.50
87	6385	9.25	0.75	-2.50	-5.50
103	6465	9.50	1.00	-2.00	-5.00
119	6545	9.25	0.75	-2.50	-5.50
135-167	6705	9.25	0.75	-2.50	-5.50
183	6865	9.25	0.75	-2.50	-5.50
199	6945	10.00	1.50	-1.50	-4.50
215	7025	10.00	1.50	-1.50	-4.50

6 GHz WLAN - 80 MHz - MIMO Core 0 & Core 1 CDD

Channel	Centre Frequency (MHz)	11ax HE80 (2Tx, CDD, non TxBF) Low Rate	11ax HE160 RU106 (2Tx, CDD, nonTxBF)	11ax HE160 RU52 (2Tx, CDD, nonTxBF)	11ax HE160 RU26 (2Tx, CDD, nonTxBF)
7	5985	3.25	-5.50	-8.50	NS
23	6065	3.25	-5.50	-8.50	NS
39-55	6185	4.50	-4.00	-7.00	NS
71	6305	4.50	-4.00	-7.00	NS
87	6385	4.50	-4.00	-7.00	NS
103	6465	4.50	-4.00	-7.00	NS
119	6545	3.75	-5.00	-8.00	NS
135-167	6705	3.75	-5.00	-8.00	NS
183	6865	3.75	-5.00	-8.00	NS
199	6945	5.25	-3.50	-6.50	NS
215	7025	5.25	-3.50	-6.50	NS



6 GHz WLAN - 80 MHz - MIMO Core 0 & Core 1 SDM

Channel	Centre Frequency (MHz)	11ax HE80 (2Tx, SDM, nonTxBF) Low Rate	11ax HE80 RU106 (2Tx, SDM, nonTxBF)	11ax HE80 RU52 (2Tx, SDM, nonTxBF)	11ax HE80 RU26 (2Tx, SDM, nonTxBF)	11ax HE80 (2Tx, TxBF) Low Rate
7	5985	6.25	-2.50	-5.50	-8.50	3.25
23	6065	6.25	-2.50	-5.50	-8.50	3.25
39-55	6185	7.50	-1.00	-4.00	-7.00	4.50
71	6305	7.25	-1.50	-4.50	-7.50	4.50
87	6385	7.25	-1.50	-4.50	-7.50	4.50
103	6465	7.50	-1.00	-4.00	-7.00	4.50
119	6545	6.75	-2.00	-5.00	-8.00	3.75
135-167	6705	6.75	-2.00	-5.00	-8.00	3.75
183	6865	6.75	-2.00	-5.00	-8.00	3.75
199	6945	8.25	-0.50	-3.50	-6.50	5.25
215	7025	8.25	-0.50	-3.50	-6.50	5.25

6 GHz WLAN - 160 MHz - SISO Core 0

Channel	Centre Frequency (MHz)	11ax HE160 (SISO) Low Rate	11ax HE160 RU106 (SISO)	11ax HE160 RU52 (SISO)	11ax HE160 RU26 (SISO)
15	6025	11.50	0.25	-3.00	-6.00
47	6185	12.50	1.50	-1.50	-4.50
79	6345	12.25	0.75	-2.50	-5.50
111	6505	10.25	0.75	-2.50	-5.50
143	6665	10.25	0.75	-2.50	-5.50
175	6825	10.25	0.75	-2.50	-5.50
207	6985	12.00	1.50	-1.50	-4.50

6 GHz WLAN - 160 MHz - SISO Core 1

Channel	Centre Frequency (MHz)	11ax HE160 (SISO) Low Rate	11ax HE160 RU106 (SISO)	11ax HE160 RU52 (SISO)	11ax HE160 RU26 (SISO)
15	6025	11.25	0.25	-3.00	-6.00
47	6185	12.00	1.50	-1.50	-4.50
79	6345	12.00	0.75	-2.50	-5.50
111	6505	10.75	0.75	-2.50	-5.50
143	6665	10.75	0.75	-2.50	-5.50
175	6825	10.75	0.75	-2.50	-5.50
207	6985	13.00	1.50	-1.50	-4.50



6 GHz WLAN - 160 MHz - MIMO Core 0 & Core 1 CDD

Channel	Centre Frequency (MHz)	11ax HE160 (2Tx, CDD, nonTxBF) Low Rate	11ax HE160 RU106 (2Tx, CDD, nonTxBF)	11ax HE160 RU52 (2Tx, CDD, nonTxBF)	11ax HE160 RU26 (2Tx, CDD, nonTxBF)
15	6025	6.25	-5.50	-8.50	NS
47	6185	7.50	-4.00	-7.00	NS
79	6345	7.50	-4.00	-7.00	NS
111	6505	6.75	-5.00	-8.00	NS
143	6665	6.75	-5.00	-8.00	NS
175	6825	6.75	-5.00	-8.00	NS
207	6985	8.25	-3.50	-6.50	NS

6 GHz WLAN - 160 MHz - MIMO Core 0 & Core 1 SDM

Channel	Centre Frequency (MHz)	11ax HE160 (2Tx, SDM, nonTxBF) Low Rate	11ax HE160 RU106 (2Tx, SDM, nonTxBF)	11ax HE160 RU52 (2Tx, SDM, nonTxBF)	11ax HE160 RU26 (2Tx, SDM, nonTxBF)
15	6025	9.25	-2.50	-5.50	-8.50
47	6185	10.50	-1.00	-4.00	-7.00
79	6345	10.25	-1.50	-4.50	-7.50
111	6505	9.75	-2.00	-5.00	-8.00
143	6665	9.75	-2.00	-5.00	-8.00
175	6825	9.75	-2.00	-5.00	-8.00
207	6985	11.25	-0.50	-3.50	-6.50



6 GHz WLAN - 20 MHz - SISO Core 0 - SP

Channel	Centre Frequency (MHz)	a (SISO) Low Rate	11ax HE20 (SISO) Low Rate	11ax HE20 RU106 (SISO)	11ax HE20 RU52 (SISO)	11ax HE20 RU26 (SISO)
2	5935	NS	NS	NS	NS	NS
1	5955	11.50	11.50	11.50	11.50	11.50
5	5975	11.50	11.50	11.50	11.50	11.50
9-29	5945	11.50	11.50	11.50	11.50	11.50
33-61	6185	11.50	11.50	11.50	11.50	11.50
65-85	6325	12.50	12.50	12.50	12.50	12.50
89	6395	12.50	12.50	12.50	12.50	12.25
93	6415	12.50	12.50	12.50	12.50	12.25
97-113	6475	12.50	12.50	12.50	12.50	12.25
117-181	6695	NS	NS	NS	NS	NS
185	6875	10.25	10.25	10.25	10.25	10.25
189-225	6985	NS	NS	NS	NS	NS
229	7095	NS	NS	NS	NS	NS
233	7115	NS	NS	NS	NS	NS

6 GHz WLAN - 20 MHz - SISO Core 1 - SP

Channel	Centre Frequency (MHz)	a (SISO) Low Rate	11ax HE20 (SISO) Low Rate	11ax HE20 RU106 (SISO)	11ax HE20 RU52 (SISO)	11ax HE20 RU26 (SISO)
2	5935	NS	NS	NS	NS	NS
1	5955	11.25	11.25	11.25	11.25	11.25
5	5975	11.25	11.25	11.25	11.25	11.25
9-29	5945	11.25	11.25	11.25	11.25	11.25
33-61	6185	11.25	11.25	11.25	11.25	11.25
65-85	6325	12.00	12.00	12.00	12.00	12.00
89	6395	12.00	12.00	12.00	12.00	12.00
93	6415	12.00	12.00	12.00	12.00	12.00
97-113	6475	12.00	12.00	12.00	12.00	12.00
117-181	6695	NS	NS	NS	NS	NS
185	6875	10.75	10.75	10.75	10.75	10.75
189-225	6985	NS	NS	NS	NS	NS
229	7095	NS	NS	NS	NS	NS
233	7115	NS	NS	NS	NS	NS



6 GHz WLAN - 20 MHz - MIMO Core 0 & Core 1 CDD - SP

Channel	Centre Frequency (MHz)	11ax HE20 (2Tx, CDD, nonTxBF) Low Rate	11ax HE20 RU106 (2Tx, CDD, nonTxBF)	11ax HE20 RU52 (2Tx, CDD, nonTxBF)	11ax HE20 RU26 (2Tx, CDD, nonTxBF)
2	5935	NS	NS	NS	NS
1	5955	11.25	11.25	9.25	6.25
5	5975	11.25	11.25	9.25	6.25
9-29	5945	11.25	11.25	9.25	6.25
33-61	6185	11.25	11.25	10.50	7.50
65-85	6325	12.00	12.00	10.50	7.50
89	6395	12.00	12.00	10.50	7.50
93	6415	12.00	12.00	10.50	7.50
97-113	6475	12.00	12.00	10.50	7.50
117-181	6695	NS	NS	NS	NS
185	6875	10.25	10.25	9.75	6.75
189-225	6985	NS	NS	NS	NS
229	7095	NS	NS	NS	NS
233	7115	NS	NS	NS	NS

6 GHz WLAN - 20 MHz - MIMO Core 0 & Core 1 SDM - SP

Channel	Centre Frequency (MHz)	11ax HE20 (2Tx, CDD, nonTxBF) Low Rate	11ax HE20 RU106 (2Tx, CDD, nonTxBF)	11ax HE20 RU52 (2Tx, CDD, nonTxBF)	11ax HE20 RU26 (2Tx, CDD, nonTxBF)	11ax HE20 (2Tx, TxBF) Low Rate
2	5935	NS	NS	NS	NS	NS
1	5955	11.25	11.25	11.25	9.25	11.25
5	5975	11.25	11.25	11.25	9.25	11.25
9-29	5945	11.25	11.25	11.25	9.25	11.25
33-61	6185	11.25	11.25	11.25	10.50	11.25
65-85	6325	12.00	12.00	12.00	10.50	12.00
89	6395	12.00	12.00	12.00	10.25	12.00
93	6415	12.00	12.00	12.00	10.25	12.00
97-113	6475	12.00	12.00	12.00	10.25	12.00
117-181	6695	NS	NS	NS	NS	NS
185	6875	10.25	10.25	10.25	9.75	10.25
189-225	6985	NS	NS	NS	NS	NS
229	7095	NS	NS	NS	NS	NS
233	7115	NS	NS	NS	NS	NS

6 GHz WLAN - 40 MHz - SISO Core 0 - SP

Channel	Centre Frequency (MHz)	11ax HE40 (SISO) Low Rate	11ax HE40 RU106 (SISO)	11ax HE40 RU52 (SISO)	11ax HE40 RU26 (SISO)
3	5965	11.50	11.50	11.50	10.50
11	6005	11.50	11.50	11.50	10.50
19-27	6065	11.50	11.50	11.50	10.50
35-59	6185	11.50	11.50	11.50	10.50
67-75	6305	12.50	12.50	12.50	10.50
83	6365	12.50	12.50	12.50	10.50
91	6405	12.50	12.50	12.50	10.50
99-107	6465	12.50	12.50	12.50	10.50
115	6525	NS	NS	NS	NS
123-179	6705	NS	NS	NS	NS
187	6885	10.25	10.25	10.25	10.25
195-219	6985	NS	NS	NS	NS
227	7085	NS	NS	NS	NS

6 GHz WLAN - 40 MHz - SISO Core 1 - SP

Channel	Centre Frequency (MHz)	11ax HE40 (SISO) Low Rate	11ax HE40 RU106 (SISO)	11ax HE40 RU52 (SISO)	11ax HE40 RU26 (SISO)
3	5965	11.25	11.25	11.25	10.50
11	6005	11.25	11.25	11.25	10.50
19-27	6065	11.25	11.25	11.25	10.50
35-59	6185	11.25	11.25	11.25	10.50
67-75	6305	12.00	12.00	12.00	10.50
83	6365	12.00	12.00	12.00	10.50
91	6405	12.00	12.00	12.00	10.50
99-107	6465	12.00	12.00	12.00	10.50
115	6525	NS	NS	NS	NS
123-179	6705	NS	NS	NS	NS
187	6885	10.75	10.75	10.75	10.50
195-219	6985	NS	NS	NS	NS
227	7085	NS	NS	NS	NS



6 GHz WLAN - 40 MHz - MIMO Core 0 & Core 1 CDD - SP

Channel	Centre Frequency (MHz)	11ax HE40 (2Tx, CDD, nonTxBF) Low Rate	11ax HE40 RU106 (2Tx, CDD, nonTxBF)	11ax HE40 RU52 (2Tx, CDD, nonTxBF)	11ax HE40 RU26 (2Tx, CDD, nonTxBF)
3	5965	11.25	11.25	9.25	6.25
11	6005	11.25	11.25	9.25	6.25
19-27	6065	11.25	11.25	9.25	6.25
35-59	6185	11.25	11.25	10.50	7.50
67-75	6305	12.00	12.00	10.50	7.50
83	6365	12.00	12.00	10.50	7.50
91	6405	12.00	12.00	10.50	7.50
99-107	6465	12.00	12.00	10.50	7.50
115	6525	NS	NS	NS	NS
123-179	6705	NS	NS	NS	NS
187	6885	10.25	10.25	9.75	6.75
195-219	6985	NS	NS	NS	NS
227	7085	NS	NS	NS	NS

6 GHz WLAN - 40 MHz - MIMO Core 0 & Core 1 SDM - SP

Channel	Centre Frequency (MHz)	11ax HE40 (2Tx, SDM, nonTxBF) Low Rate	11ax HE40 RU106 (2Tx, SDM, nonTxBF)	11ax HE40 RU52 (2Tx, SDM, nonTxBF)	11ax HE40 RU26 (2Tx, SDM, nonTxBF)	11ax HE40 (2Tx, TxBF) Low Rate
3	5965	11.25	11.25	11.25	9.25	11.25
11	6005	11.25	11.25	11.25	9.25	11.25
19-27	6065	11.25	11.25	11.25	9.25	11.25
35-59	6185	11.25	11.25	11.25	10.50	11.25
67-75	6305	12.00	12.00	12.00	10.50	12.00
83	6365	12.00	12.00	12.00	10.25	12.00
91	6405	12.00	12.00	12.00	10.25	12.00
99-107	6465	12.00	12.00	12.00	10.25	12.00
115	6525	NS	NS	NS	NS	NS
123-179	6705	NS	NS	NS	NS	NS
187	6885	10.25	10.25	10.25	9.75	10.25
195-219	6985	NS	NS	NS	NS	NS
227	7085	NS	NS	NS	NS	NS

6 GHz WLAN - 80 MHz - SISO Core 0 - SP

Channel	Centre Frequency (MHz)	11ax HE80 (SISO) Low Rate	11ax HE80 RU106 (SISO)	11ax HE80 RU52 (SISO)	11ax HE80 RU26 (SISO)
7	5985	11.50	11.50	10.50	7.50
23	6065	11.50	11.50	10.50	7.50
39-55	6185	11.50	11.50	10.50	7.50
71	6305	12.50	12.50	10.50	7.50
87	6385	12.50	12.50	10.50	7.50
103	6465	12.50	12.50	10.50	7.50
119	6545	NS	NS	NS	NS
135-167	6705	NS	NS	NS	NS
183	6865	10.25	10.25	10.25	7.50
199	6945	NS	NS	NS	NS
215	7025	NS	NS	NS	NS

6 GHz WLAN - 80 MHz - SISO Core 1 - SP

Channel	Centre Frequency (MHz)	11ax HE80 (SISO) Low Rate	11ax HE80 RU106 (SISO)	11ax HE80 RU52 (SISO)	11ax HE80 RU26 (SISO)
7	5985	11.25	11.25	10.50	7.50
23	6065	11.25	11.25	10.50	7.50
39-55	6185	11.25	11.25	10.50	7.50
71	6305	12.00	12.00	10.50	7.50
87	6385	12.00	12.00	10.50	7.50
103	6465	12.00	12.00	10.50	7.50
119	6545	NS	NS	NS	NS
135-167	6705	NS	NS	NS	NS
183	6865	10.75	10.75	10.50	7.50
199	6945	NS	NS	NS	NS
215	7025	NS	NS	NS	NS



6 GHz WLAN - 80 MHz - MIMO Core 0 & Core 1 CDD - SP

Channel	Centre Frequency (MHz)	11ax HE80 (2Tx, CDD, nonTxBF) Low Rate	11ax HE80 RU106 (2Tx, CDD, nonTxBF)	11ax HE80 RU52 (2Tx, CDD, nonTxBF)	11ax HE80 RU26 (2Tx, CDD, nonTxBF)
7	5985	11.25	11.25	9.25	6.25
23	6065	11.25	11.25	9.25	6.25
39-55	6185	11.25	11.25	10.50	7.50
71	6305	12.00	12.00	10.50	7.50
87	6385	12.00	12.00	10.50	7.50
103	6465	12.00	12.00	10.50	7.50
119	6545	NS	NS	NS	NS
135-167	6705	NS	NS	NS	NS
183	6865	10.25	10.25	9.75	6.75
199	6945	NS	NS	NS	NS
215	7025	NS	NS	NS	NS

6 GHz WLAN - 80 MHz - MIMO Core 0 & Core 1 SDM - SP

Channel	Centre Frequency (MHz)	11ax HE80 (2Tx, SDM, nonTxBF) Low Rate	11ax HE80 RU106 (2Tx, SDM, nonTxBF)	11ax HE80 RU52 (2Tx, SDM, nonTxBF)	11ax HE80 RU26 (2Tx, SDM, nonTxBF)	11ax HE80 (2Tx, TxBF) Low Rate
7	5985	11.25	11.25	10.50	7.50	11.25
23	6065	11.25	11.25	10.50	7.50	11.25
39-55	6185	11.25	11.25	10.50	7.50	11.25
71	6305	12.00	12.00	10.50	7.50	12.00
87	6385	12.00	12.00	10.50	7.50	12.00
103	6465	12.00	12.00	10.50	7.50	12.00
119	6545	NS	NS	NS	NS	NS
135-167	6705	NS	NS	NS	NS	NS
183	6865	10.25	13.50	10.25	7.50	10.25
199	6945	NS	NS	NS	NS	NS
215	7025	NS	NS	NS	NS	NS

6 GHz WLAN - 160 MHz - SISO Core 0 - SP

Channel	Centre Frequency (MHz)	11ax HE160 (SISO) Low Rate	11ax HE160 RU106 (SISO)	11ax HE160 RU52 (SISO)	11ax HE160 RU26 (SISO)
15	6025	11.50	10.50	7.50	4.50
47	6185	12.50	10.50	7.50	4.50
79	6345	12.50	10.50	7.50	4.50
111	6505	NS	NS	NS	NS
143	6665	10.25	10.25	7.50	4.50
175	6825	NS	NS	NS	NS
207	6985	NS	NS	NS	NS

6 GHz WLAN - 160 MHz - SISO Core 1 - SP

Channel	Centre Frequency (MHz)	11ax HE160 (SISO) Low Rate	11ax HE160 RU106 (SISO)	11ax HE160 RU52 (SISO)	11ax HE160 RU26 (SISO)
15	6025	11.25	10.50	7.50	4.50
47	6185	12.00	10.50	7.50	4.50
79	6345	12.00	10.50	7.50	4.50
111	6505	NS	NS	NS	NS
143	6665	10.75	10.50	7.50	4.50
175	6825	NS	NS	NS	NS
207	6985	NS	NS	NS	NS

6 GHz WLAN - 160 MHz - MIMO Core 0 & Core 1 CDD - SP

Channel	Centre Frequency (MHz)	11ax HE160 (2Tx, CDD, nonTxBF) Low Rate	11ax HE160 RU106 (2Tx, CDD, nonTxBF)	11ax HE160 RU52 (2Tx, CDD, nonTxBF)	11ax HE160 RU26 (2Tx, CDD, nonTxBF)
15	6025	11.25	10.50	7.50	4.50
47	6185	12.00	10.50	7.50	4.50
79	6345	12.00	10.50	7.50	4.50
111	6505	NS	NS	NS	NS
143	6665	10.25	10.25	7.50	4.50
175	6825	NS	NS	NS	NS
207	6985	NS	NS	NS	NS



6 GHz WLAN - 160 MHz - MIMO Core 0 & Core 1 SDM - SP

Channel	Centre Frequency (MHz)	11ax HE160 (2Tx, SDM, nonTxBF) Low Rate	11ax HE160 RU106 (2Tx, SDM, nonTxBF)	11ax HE160 RU52 (2Tx, SDM, nonTxBF)	11ax HE160 RU26 (2Tx, SDM, nonTxBF)
15	6025	11.25	10.50	7.50	4.50
47	6185	12.00	10.50	7.50	4.50
79	6345	12.00	10.50	7.50	4.50
111	6505	NS	NS	NS	NS
143	6665	10.25	10.25	7.50	4.50
175	6825	NS	NS	NS	NS
207	6985	NS	NS	NS	NS



1.5 CONDUCTED POWER MEASUREMENTS

1.5.1 Method

Conducted power measurements were made using a power meter.

1.5.2 Measured Results

Bluetooth (When 5.0 GHz WLAN OFF) - EDR

(BT Core 0 - ePA)

Technology	Channel	Modulation	Duty Cycle (%)	Packet Type	Frequency (MHz)	Measured Power (dBm)	Tune Up (dBm)
EDR	0	8-DPSK	77	3-DH5	2402	14.60	16.50
EDR	39	8-DPSK	77	3-DH5	2441	14.62	16.50
EDR	78	8-DPSK	77	3-DH5	2480	14.50	16.50

(BT Core 1 - ePA)

Technology	Channel	Modulation	Duty Cycle (%)	Packet Type	Frequency (MHz)	Measured Power (dBm)	Tune Up (dBm)
EDR	0	8-DPSK	77	3-DH5	2402	15.10	16.50
EDR	39	8-DPSK	77	3-DH5	2441	14.55	16.50
EDR	78	8-DPSK	77	3-DH5	2480	14.59	16.50

BDR

(BT Core 2 - IPA)

Technology	Channel	Modulation	Duty Cycle (%)	Packet Type	Frequency (MHz)	Measured Power (dBm)	Tune Up (dBm)
BDR	0	8-DPSK	77	DH5	2402	12.70	13.00
BDR	39	8-DPSK	77	DH5	2441	12.86	13.00
BDR	78	8-DPSK	77	DH5	2480	12.91	13.00



Bluetooth (When 5.0 GHz WLAN ON) - EDR

(BT Core 0 - ePA)

Technology	Channel	Modulation	Duty Cycle (%)	Packet Type	Frequency (MHz)	Measured Power (dBm)	Tune Up (dBm)
EDR	0	8-DPSK	77	3-DH5	2402	14.60	15.50
EDR	39	8-DPSK	77	3-DH5	2441	14.62	15.50
EDR	78	8-DPSK	77	3-DH5	2480	14.50	15.50

(BT Core 1 - ePA)

Technology	Channel	Modulation	Duty Cycle (%)	Packet Type	Frequency (MHz)	Measured Power (dBm)	Tune Up (dBm)
EDR	0	8-DPSK	77	3-DH5	2402	15.10	15.50
EDR	39	8-DPSK	77	3-DH5	2441	14.55	15.50
EDR	78	8-DPSK	77	3-DH5	2480	14.59	15.50

BDR

(BT Core 2 - IPA)

Technology	Channel	Modulation	Duty Cycle (%)	Packet Type	Frequency (MHz)	Measured Power (dBm)	Tune Up (dBm)
BDR	0	8-DPSK	77	DH5	2402	12.70	13.00
BDR	39	8-DPSK	77	DH5	2441	12.86	13.00
BDR	78	8-DPSK	77	DH5	2480	12.91	13.00



Narrowband UNII-1 - When 2.4 GHz WLAN OFF

(UNII-1 - Core 0)

Technology	Channel	Modulation	Duty Cycle (%)	Packet Type	Frequency (MHz)	Measured Power (dBm)	Tune Up (dBm)
HDR8	Bottom	8-DPSK	78	8DH5	5150	12.20	12.50
HDR8	Middle	8-DPSK	78	8DH5	5200	11.95	12.50
HDR8	Top	8-DPSK	78	8DH5	5250	12.20	12.50

(UNII-1 - Core 1)

Technology	Channel	Modulation	Duty Cycle (%)	Packet Type	Frequency (MHz)	Measured Power (dBm)	Tune Up (dBm)
HDR8	Bottom	8-DPSK	78	8DH5	5150	12.68	13.50
HDR8	Middle	8-DPSK	78	8DH5	5200	12.98	13.50
HDR8	Top	8-DPSK	78	8DH5	5250	13.02	13.50

Narrowband UNII-1 - When 2.4 GHz WLAN ON

(UNII-1 - Core 0)

Technology	Channel	Modulation	Duty Cycle (%)	Packet Type	Frequency (MHz)	Measured Power (dBm)	Tune Up (dBm)
HDR8	Bottom	8-DPSK	78	8DH5	5150	10.38	10.50
HDR8	Middle	8-DPSK	78	8DH5	5200	10.22	10.50
HDR8	Top	8-DPSK	78	8DH5	5250	10.20	10.50

(UNII-1 - Core 1)

Technology	Channel	Modulation	Duty Cycle (%)	Packet Type	Frequency (MHz)	Measured Power (dBm)	Tune Up (dBm)
HDR4	Bottom	8-DPSK	78	4DH5	5150	9.52	10.00
HDR4	Middle	8-DPSK	78	4DH5	5200	9.30	10.00
HDR4	Top	8-DPSK	78	4DH5	5250	9.50	10.00



Narrowband UNII-3- When 2.4 GHz WLAN OFF

(UNII-3 - Core 0)

Technology	Channel	Modulation	Duty Cycle (%)	Packet Type	Frequency (MHz)	Measured Power (dBm)	Tune Up (dBm)
HDR4	Bottom	8-DPSK	78	4DH5	5725	14.55	15.00
HDR4	Middle	8-DPSK	78	4DH5	5788	14.53	15.00
HDR4	Top	8-DPSK	78	4DH5	5850	14.51	15.00

(UNII-3 - Core 1)

Technology	Channel	Modulation	Duty Cycle (%)	Packet Type	Frequency (MHz)	Measured Power (dBm)	Tune Up (dBm)
HDR4	Bottom	8-DPSK	78	4DH5	5725	14.42	14.50
HDR4	Middle	8-DPSK	78	4DH5	5788	14.10	14.50
HDR4	Top	8-DPSK	78	4DH5	5850	14.20	14.50

Narrowband UNII-3- When 2.4 GHz WLAN ON

(UNII-3 - Core 0)

Technology	Channel	Modulation	Duty Cycle (%)	Packet Type	Frequency (MHz)	Measured Power (dBm)	Tune Up (dBm)
HDR8	Bottom	8-DPSK	78	8DH5	5725	12.95	13.50
HDR8	Middle	8-DPSK	78	8DH5	5788	12.92	13.50
HDR8	Top	8-DPSK	78	8DH5	5850	13.43	13.50

(UNII-3 - Core 1)

Technology	Channel	Modulation	Duty Cycle (%)	Packet Type	Frequency (MHz)	Measured Power (dBm)	Tune Up (dBm)
HDR4	Bottom	8-DPSK	78	4DH5	5725	9.35	10.00
HDR4	Middle	8-DPSK	78	4DH5	5788	9.65	10.00
HDR4	Top	8-DPSK	78	4DH5	5850	9.83	10.00



Thread (When 5.0 GHz WLAN OFF)

(Core 0 - ePA)

Technology	Channel	Modulation	Duty Cycle (%)	Packet Type	Frequency (MHz)	Measured Power (dBm)	Tune Up (dBm)
Thread	11	OQPSK	60	N/A	2405	19.45	20.00
Thread	18	OQPSK	60	N/A	2440	19.81	20.00
Thread	26	OQPSK	60	N/A	2480	19.25	20.00

(Core 1 - ePA)

Technology	Channel	Modulation	Duty Cycle (%)	Packet Type	Frequency (MHz)	Measured Power (dBm)	Tune Up (dBm)
Thread	11	OQPSK	60	N/A	2405	19.66	20.00
Thread	18	OQPSK	60	N/A	2440	19.80	20.00
Thread	26	OQPSK	60	N/A	2480	19.50	20.00

(Core 2 - iPA)

Technology	Channel	Modulation	Duty Cycle (%)	Packet Type	Frequency (MHz)	Measured Power (dBm)	Tune Up (dBm)
Thread	11	OQPSK	60	N/A	2405	12.20	12.50
Thread	18	OQPSK	60	N/A	2440	12.25	12.50
Thread	26	OQPSK	60	N/A	2480	12.25	12.50



Thread (When 5.0 GHz WLAN ON)

(Core 0 - ePA)

Technology	Channel	Modulation	Duty Cycle (%)	Packet Type	Frequency (MHz)	Measured Power (dBm)	Tune Up (dBm)
Thread	11	OQPSK	60	N/A	2405	14.88	15.50
Thread	18	OQPSK	60	N/A	2440	14.55	15.50
Thread	26	OQPSK	60	N/A	2480	14.63	15.50

(Core 1 - ePA)

Technology	Channel	Modulation	Duty Cycle (%)	Packet Type	Frequency (MHz)	Measured Power (dBm)	Tune Up (dBm)
Thread	11	OQPSK	60	N/A	2405	14.91	15.50
Thread	18	OQPSK	60	N/A	2440	14.62	15.50
Thread	26	OQPSK	60	N/A	2480	15.38	15.50

(Core 2 - iPA)

Technology	Channel	Modulation	Duty Cycle (%)	Packet Type	Frequency (MHz)	Measured Power (dBm)	Tune Up (dBm)
Thread	11	OQPSK	60	N/A	2405	12.20	12.50
Thread	18	OQPSK	60	N/A	2440	12.25	12.50
Thread	26	OQPSK	60	N/A	2480	12.25	12.50



WLAN 2.4 GHz - SISO

(Core 0)

Technology	Channel	Modulation	Duty Cycle (%)	Rate (Mbps)	Frequency (MHz)	Measured Power (dBm)	Tune Up (dBm)
802.11g	2	BPSK	100	6.0	2417	18.69	19.25
802.11g	6	BPSK	100	6.0	2437	19.00	19.25
802.11g	10	BPSK	100	6.0	2457	18.76	19.25

(Core 1)

Technology	Channel	Modulation	Duty Cycle (%)	Rate (Mbps)	Frequency (MHz)	Measured Power (dBm)	Tune Up (dBm)
802.11g	2	BPSK	100	6.0	2417	18.92	19.25
802.11g	6	BPSK	100	6.0	2437	18.90	19.25
802.11g	10	BPSK	100	6.0	2457	18.88	19.25

**WLAN 2.4 GHz - 2x2 MIMO****(Core 0)**

Technology	Channel	Modulation	Duty Cycle (%)	Rate (Mbps)	Frequency (MHz)	Measured Power (dBm)	Tune Up (dBm)
11n HT20 (2Tx, nonTXBF) (Core 0)	2	BPSK	100	6.5	2417	18.51	19.25
11n HT20 (2Tx, nonTXBF) (Core 1)	2	BPSK	100	6.5	2417	18.50	19.25
11n HT20 (2Tx, nonTXBF) (Core 0)	6	BPSK	100	6.5	2437	18.76	19.25
11n HT20 (2Tx, nonTXBF) (Core 1)	6	BPSK	100	6.5	2437	18.58	19.25
11n HT20 (2Tx, nonTXBF) (Core 0)	10	BPSK	100	6.5	2457	18.38	19.25
11n HT20 (2Tx, nonTXBF) (Core 1)	10	BPSK	100	6.5	2457	18.28	19.25



WLAN U-NII 1/2A – 5.2/3 GHz SISO

(Core 0)

Technology	Channel	Modulation	Duty Cycle (%)	Rate (Mbps)	Frequency (MHz)	Measured Power (dBm)	Tune Up (dBm)
802.11ac VHT80	42	BPSK	100	29.3	5210	13.05	13.75
802.11ac VHT160	50	BPSK	100	58.5	5250	11.78	12.50
802.11ac VHT80	58	BPSK	100	29.3	5290	12.02	12.50

(Core 1)

Technology	Channel	Modulation	Duty Cycle (%)	Rate (Mbps)	Frequency (MHz)	Measured Power (dBm)	Tune Up (dBm)
802.11ac VHT80	42	BPSK	100	29.3	5210	13.07	13.50
802.11ac VHT160	50	BPSK	100	58.5	5250	12.33	13.00
802.11ac VHT80	58	BPSK	100	29.3	5290	12.65	13.00

MIMO

Technology	Channel	Modulation	Duty Cycle (%)	Rate (Mbps)	Frequency (MHz)	Measured Power (dBm)	Tune Up (dBm)
11ac VHT80 (2Tx, SDM, nonTxBF) Low Rate (Core 0)	42	BPSK	100	29.3	5210	12.92	13.50
11ac VHT80 (2Tx, SDM, nonTxBF) Low Rate (Core 1)	42	BPSK	100	29.3	5210	13.08	13.50
11ac VHT80 (2Tx, SDM, nonTxBF) Low Rate (Core 0)	58	BPSK	100	29.3	5290	12.42	12.50
11ac VHT80 (2Tx, SDM, nonTxBF) Low Rate (Core 1)	58	BPSK	100	29.3	5290	12.07	12.50



WLAN U-NII 2C - 5.5.0 GHz SISO

(Core 0)

Technology	Channel	Modulation	Duty Cycle (%)	Rate (Mbps)	Frequency (MHz)	Measured Power (dBm)	Tune Up (dBm)
802.11ac VHT80	106	BPSK	100	29.3	5530	13.39	13.75
802.11ac VHT80	122	BPSK	100	29.3	5610	13.34	13.75
802.11ac VHT80	138	BPSK	100	29.3	5690	13.40	13.75

(Core 1)

Technology	Channel	Modulation	Duty Cycle (%)	Rate (Mbps)	Frequency (MHz)	Measured Power (dBm)	Tune Up (dBm)
802.11ac VHT80	106	BPSK	100	29.3	5530	12.14	12.75
802.11ac VHT160	114	BPSK	100	58.5	5570	12.14	12.75
802.11ac VHT80	122	BPSK	100	29.3	5610	12.38	12.75
802.11ac VHT80	138	BPSK	100	29.3	5690	12.50	12.75

**MIMO**

Technology	Channel	Modulation	Duty Cycle (%)	Rate (Mbps)	Frequency (MHz)	Measured Power (dBm)	Tune Up (dBm)
11ac VHT80 (2Tx, SDM, nonTXBF) Low Rate (Core 0)	106	BPSK	100	29.3	5530	11.95	12.75
11ac VHT80 (2Tx, SDM, nonTXBF) Low Rate (Core 1)	106	BPSK	100	29.3	5530	12.07	12.75
11ac VHT80 (2Tx, SDM, nonTXBF) Low Rate (Core 0)	122	BPSK	100	29.3	5610	12.47	12.75
11ac VHT80 (2Tx, SDM, nonTXBF) Low Rate (Core 1)	122	BPSK	100	29.3	5610	12.31	12.75
11ac VHT80 (2Tx, SDM, nonTXBF) Low Rate (Core 0)	138	BPSK	100	29.3	5690	12.32	12.75
11ac VHT80 (2Tx, SDM, nonTXBF) Low Rate (Core 1)	138	BPSK	100	29.3	5690	12.21	12.75



WLAN U-NII 3 – 5.8 GHz SISO

(Core 0)

Technology	Channel	Modulation	Duty Cycle (%)	Rate (Mbps)	Frequency (MHz)	Measured Power (dBm)	Tune Up (dBm)
11ac VHT80 (SISO) Low Rate	155	BPSK	100	29.3	5775	13.27	13.75

(Core 1)

Technology	Channel	Modulation	Duty Cycle (%)	Rate (Mbps)	Frequency (MHz)	Measured Power (dBm)	Tune Up (dBm)
11ac VHT80 (SISO) Low Rate	155	BPSK	100	29.3	5775	12.53	13.25

MIMO

Technology	Channel	Modulation	Duty Cycle (%)	Rate (Mbps)	Frequency (MHz)	Measured Power (dBm)	Tune Up (dBm)
11ac VHT80 (2Tx, SDM, nonTXBF) Low Rate (Core 0)	155	BPSK	100	29.3	5775	12.67	13.25
11ac VHT80 (2Tx, SDM, nonTXBF) Low Rate (Core 1)	155	BPSK	100	29.3	5775	12.83	13.25

**WLAN 6 GHz SISO****(Core 0)**

Technology	Channel	Modulation	Duty Cycle (%)	Rate (Mbps)	Frequency (MHz)	Measured Power (dBm)	Tune Up (dBm)
11ax HE160 (SISO) Low Rate	15	BPSK	100	58.5	6025	11.50	11.50
11ax HE160 (SISO) Low Rate	47	BPSK	100	58.5	6185	12.50	12.50
11ax HE160 (SISO) Low Rate	79	BPSK	100	58.5	6345	12.01	12.25
11ax HE160 (SISO) Low Rate	111	BPSK	100	58.5	6505	10.07	10.25
11ax HE160 (SISO) Low Rate	143	BPSK	100	58.5	6665	10.00	10.25
11ax HE160 (SISO) Low Rate	175	BPSK	100	58.5	6825	9.94	10.25
11ax HE160 (SISO) Low Rate	207	BPSK	100	58.5	6985	11.95	12.00

(Core 1)

Technology	Channel	Modulation	Duty Cycle (%)	Rate (Mbps)	Frequency (MHz)	Measured Power (dBm)	Tune Up (dBm)
11ax HE160 (SISO) Low Rate	15	BPSK	100	58.5	6025	11.24	11.25
11ax HE160 (SISO) Low Rate	47	BPSK	100	58.5	6185	11.58	12.00
11ax HE160 (SISO) Low Rate	79	BPSK	100	58.5	6345	11.74	12.00
11ax HE160 (SISO) Low Rate	111	BPSK	100	58.5	6505	10.41	10.75
11ax HE160 (SISO) Low Rate	143	BPSK	100	58.5	6665	10.67	10.75
11ax HE160 (SISO) Low Rate	175	BPSK	100	58.5	6825	10.45	10.75
11ax HE160 (SISO) Low Rate	207	BPSK	100	58.5	6985	12.20	13.00



MIMO

Technology	Channel	Modulation	Duty Cycle (%)	Rate (Mbps)	Frequency (MHz)	Measured Power (dBm)	Tune Up (dBm)
11ax HE160 (SISO) Low Rate (Core 0)	15	BPSK	100	58.5	6025	11.00	11.25
11ax HE160 (SISO) Low Rate (Core 1)	15	BPSK	100	58.5	6025	10.70	11.25
11ax HE160 (SISO) Low Rate (Core 0)	47	BPSK	100	58.5	6185	10.23	12.00
11ax HE160 (SISO) Low Rate (Core 1)	47	BPSK	100	58.5	6185	10.17	12.00
11ax HE160 (SISO) Low Rate (Core 0)	79	BPSK	100	58.5	6345	11.70	12.00
11ax HE160 (SISO) Low Rate (Core 1)	79	BPSK	100	58.5	6345	11.69	12.00
11ax HE160 (SISO) Low Rate (Core 0)	111	BPSK	100	58.5	6505	9.65	9.75
11ax HE160 (SISO) Low Rate (Core 1)	111	BPSK	100	58.5	6505	9.48	9.75
11ax HE160 (SISO) Low Rate (Core 0)	143	BPSK	100	58.5	6665	9.60	10.25
11ax HE160 (SISO) Low Rate (Core 1)	143	BPSK	100	58.5	6665	9.10	10.25
11ax HE160 (SISO) Low Rate (Core 0)	175	BPSK	100	58.5	6825	9.70	9.75
11ax HE160 (SISO) Low Rate (Core 1)	175	BPSK	100	58.5	6825	9.50	9.75
11ax HE160 (SISO) Low Rate (Core 0)	207	BPSK	100	58.5	6985	10.99	11.25
11ax HE160 (SISO) Low Rate (Core 1)	207	BPSK	100	58.5	6985	10.98	11.25



SECTION 2

TEST DETAILS

Specific Absorption Rate Testing of the A2992

2.1 DASY6 MEASUREMENT SYSTEM

2.1.1 System Description

The DASY6 system for performing compliance tests consists of the following items:

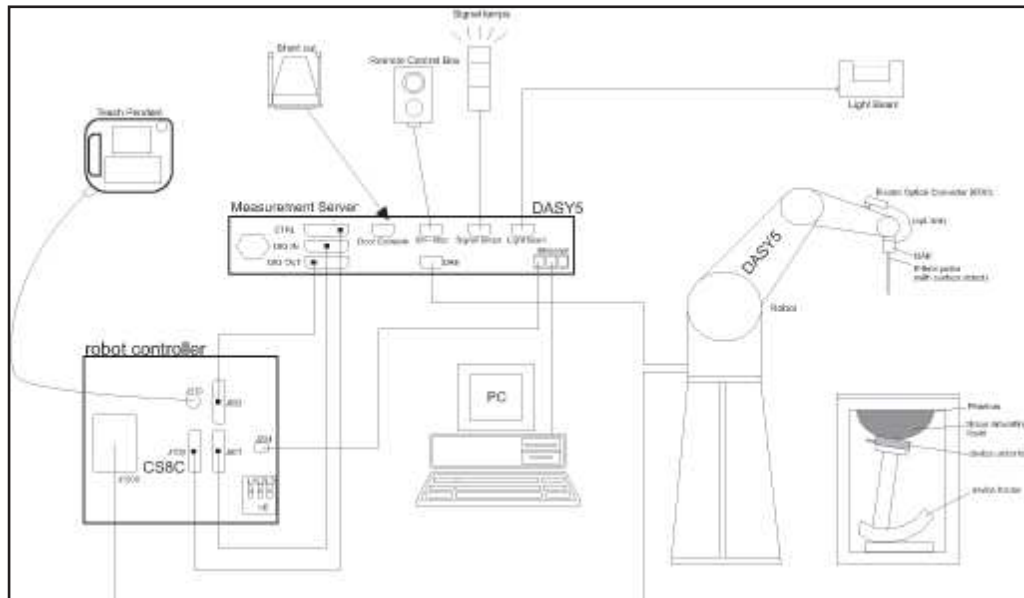

Figure 2 System Description Diagram

A standard high precision 6-axis robot (Stäubli TX=RX family) with controller, teach pendant and software. An arm extension for accommodating the data acquisition electronics (DAE).

An isotropic field probe optimized and calibrated for the targeted measurement.

A data acquisition electronics (DAE) which performs the signal amplification, signal multiplexing, AD-conversion, offset measurements, mechanical surface detection, collision detection, etc. The unit is battery powered with standard or rechargeable batteries. The signal is optically transmitted to the EOC.

The Electro-optical converter (EOC) performs the conversion from optical to electrical signals for the digital communication to the DAE. To use optical surface detection, a special version of the EOC is required. The EOC signal is transmitted to the measurement server.

The function of the measurement server is to perform the time critical tasks such as signal filtering, control of the robot operation and fast movement interrupts.

The Light Beam used is for probe alignment. This improves the (absolute) accuracy of the probe positioning.

A computer running the DASY6 software to display and interact with the robot and information.

There is a remote control and a teach pendant as well as additional circuitry for robot safety such as warning lamps, etc.

The phantom, the device holder and other accessories according to the targeted measurement.



2.1.2 Probe Specification

The probes used by the DASY system are isotropic E-field probes, constructed with a symmetric design and a triangular core. The probes have built-in shielding against static charges and are contained within a PEEK enclosure material. These probes are specially designed and calibrated for use in liquids with high permittivity. The frequency range of the probes are from 6 MHz to 6 GHz.

2.1.3 Data Acquisition Electronics

The data acquisition electronics (DAE4 or DAE3) consist of a highly sensitive electrometer-grade preamplifier with auto-zeroing, a channel and gain-switching multiplexer, a fast 16 bit AD-converter and a command decoder with a control logic unit. Transmission to the measurement server is accomplished through an optical downlink for data and status information, as well as an optical uplink for commands and the clock.

The mechanical probe mounting device includes two different sensor systems for frontal and sideways probe contacts. They are used for mechanical surface detection and probe collision detection. The input impedance of both the DAE4 as well as of the DAE3 box is 200M Ω ; the inputs are symmetrical and floating. Common mode rejection is above 80 dB.

2.1.4 SAR Evaluation Description

The cDASY6 software includes all numerical procedures necessary to evaluate the spatial peak SAR values.

Fast Area Scan:

The Fast Area Scan provides an easy, time efficient and accurate way to define the optimal power reference location. The location of the power reference and power drift measurements for the subsequent Area, Fast Volume and Zoom Scans will be automatically set at the maximum of the Fast Area Scan.

Area Scan:

Area Scans are used to determine the peak location of the measured field before doing a finer measurement around the hotspot. Peak location can be found accurately even on coarse grids using the advanced interpolation routines implemented in cDASY6 Module SAR. Area Scans measure a two dimensional volume covering the full device under test area. cDASY6 Module SAR uses Fast Averaged SAR algorithm to compute the 1g and 10g of simulated tissue from the Area Scan.

Fast Volume Scans:

Fast Volume Scans are 3D scans used to assess the peak spatial SAR values within an averaging volume containing 1g and 10g of simulated tissue. It is compatible with any phantom. For regular phantoms, the measurement grid is generated by projecting a plane onto the phantom surface as for Area and Zoom scans. For specific phantoms, the measurement grid is generated by a conformal offset to the phantom surface at the desired distances. The grid extents can be set by the end user to cover the DUT dimensions or the whole measurable area of the phantom.

**Zoom Scan:**

Zoom scans are used to assess the peak spatial SAR values within a cubic averaging volume containing 1g and 10g of simulated tissue. Zoom scans measure a three dimensional volume (cube). The bottom face of the cube is Centreed on the maximum of the preceding Area Scan in the same measurement group. For maxima at border of the phantom, the zoom scan can be enabled to automatically extend in order to ensure correct evaluation of peak spatial SAR.

Zoom Scans can be performed in two different modes:

Smart Mode: the grid settings are adjusted on the fly based on the distribution being measured to fulfill to the IEC 62209-2 Amendment 1 criteria on grid resolution.

Custom Mode: the user specifies the grid settings to be used. In both modes, Zoom Scans are always anchored to the peak location of the preceding Fast Area / Area / Fast Volume Scan.

2.1.5 DASYS 6 Absorbed Power Density evaluation.

The DASYS 6 measurement system will output the absorbed power density result values by default from version 16.0 of DASYS software onwards. All the measurement details described in this section are utilised to collect the required data which is converted automatically within the software and displayed for frequencies above 5.9 GHz.



2.2 DASY 6 mmWave PD Module

2.2.1 Measurement system

A DASY 6 measurement system equipped with the DASY 6 mmWave module was used to carry out the peak spatially averaged power density (psPD) measurements. It consists of a 6-axis industrial robot and controller that provides a highly accurate positioning system, a PC for the system control software, a near field probe (EUmmWVx), a probe alignment sensor and the 5G phantom. The high accuracy positioning system places the near field probe at the key location points of the maximum electromagnetic field.

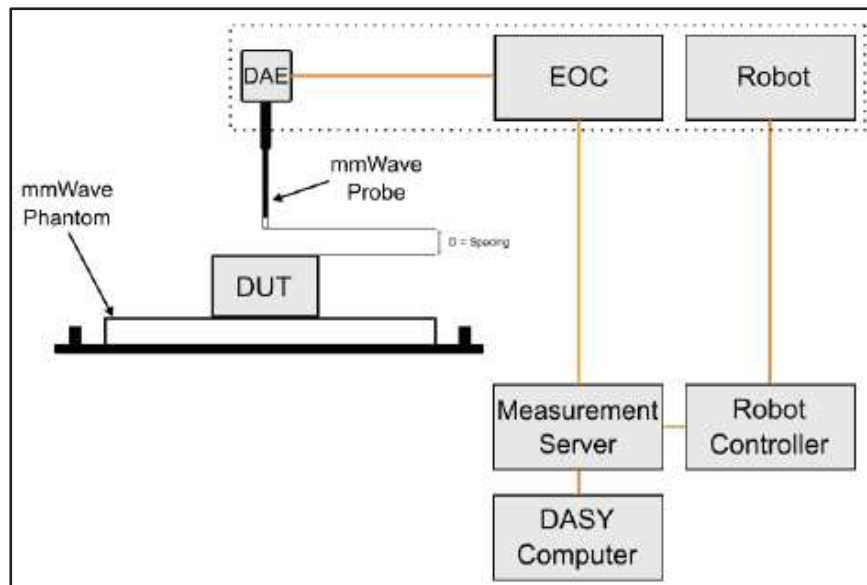

Typical measurement setup for PD measurement with DASY 6



2.2.2 EUmWVx E-field probe details

The EUmWVx probe utilises two dipole elements that are specifically arranged to allow for the generation of pseudo-vector data.

Frequency Range	750 MHz – 110 GHz
Dynamic Range	<20 V/m – 10'000 V/m with PRE-10 (min <20 V/m – 2000 V/m)
Position Precision	<0.2 mm (DASY6)
Dimensions	Overall length: 320 mm (tip: 20 mm) Tip and body diameter: encapsulation 8 mm (internal sensor <1mm) Distance from probe tip to sensor Y cal point:1.5 mm Distance from probe tip to sensor X cal point:1.5 mm
Applications	E-field measurements of 5G devices and other mm-wave transmitters operating above 10GHz in <2 mm distance from device (free-space) Power density, H-field, and far-field analysis using total field reconstruction.
Compatibility	cDASY6 + 5G-Module SW1.0 and higher

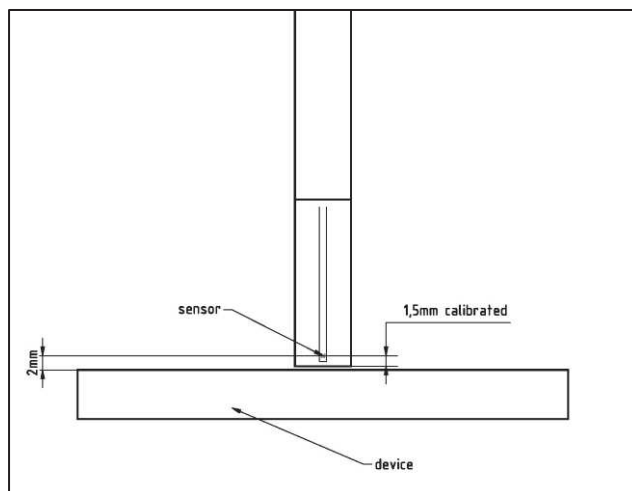

Diagram of the distance sensor to the EUT surface



2.2.3 Peak spatially averaged power density assessment based on E-field measurements

Power density was determined for both the electric and magnetic fields within a small distance from the transmitting source. In general, the magnitude and phase of two components of either E-field or H-field are needed on a sufficiently large surface to characterise their total distributions. Despite this being the case, a solution based on the direct measurement of the E and H field can be used to compute power density. The measurement approach to achieve this is given below.

- a) The local E-field is measured at a reference point on the measurement surface where the field is well above the system noise floor. This reference point is re-visited at the end of the measurement routine and re-measured to determine and assess the power drift of the EUT.
- b) The electric field on the measurement surface was scanned using instructions provided by the test system manufacturer. The spatial resolution of the measurement can depend on the measured field characteristic and measurement methodology used by the test system. The planar scan step size is configured to be $\lambda/4$.
- c) DASY6 uses a reconstruction algorithm to calculate the H-field from the measured E-field. As the power density calculation requires amplitude and phase, reconstruction algorithms can also be used to obtain field information from the measured E-field data, for example phase information from the amplitude if only the amplitude is measured. Three measurements per point on two measurement planes separated by $\lambda/4$ are carried out in order for the H-field and phase data to be reconstructed.
- d) Using the equation below the total peak spatially averaged power density (psPD) distribution on the evaluation surface can be determined. The applicable regulatory requirements specify the spatial averaging area A. A circular shape is used.

$$psPD = \frac{1}{2A_{av}} \iint_{A_{av}} ||\text{Re}\{E \times H^*\} || dA$$

- e) The final quantity used to determine compliance against the applicable limits is the maximum spatial average on the evaluation.
- f) Following the measurement of the power drift as described in step a) the drift was assessed. If the drift deviated by more than 5% then the power density test and drift measurements shall be repeated.



2.2.4 Reconstruction Algorithm

Computation of the PD in general requires knowledge of the electric (E-) and magnetic (H-) field amplitudes and phases in the plane of incidence. Reconstruction of these quantities from pseudo-vector E-field measurements is feasible, as they are constrained by Maxwell's equations.

The test system utilises a reconstruction approach based on the Gerchberg-Saxton algorithm which benefits from the availability of the E-field polarization ellipse information obtained with the EUmmWVx probe. This reconstruction algorithm, together with the ability of the probe to measure extremely close to the source without perturbing the field, permits reconstruction of the E- and H-fields and the PD on measurement planes located as near as $\lambda/2\pi$.

2.2.5 Standalone PD limit

The following formula provides the reference levels for local exposure to electromagnetic fields from >6 GHz to 300GHz for general public as referenced in ICNIRP 2020:

$$55/f_G^{0.177}$$

The FCC Oct 2020 TCB workshop states their own incident power density limit of 1mW/cm² plane-wave equivalent, averaged over 4 cm² as reflected in FCC 47 CFR 1.1310.

2.2.6 Exposure Ratio

The following formulas used to calculate the exposure ratio of SAR, APD and iPD respectively as referenced in ICNIRP 2020:

$$\text{SAR} \quad \sum_{i=100 \text{ kHz}}^{300 \text{ GHz}} \frac{\text{SAR}_i}{\text{SAR}_{BR}} \leq 1$$

$$\text{APD} \quad \sum_{i>6 \text{ GHz}}^{30 \text{ GHz}} \frac{S_{ab,4cm,i}}{S_{ab,4cm,BR}} \leq 1$$

$$\text{iPD} \quad \sum_{i>6 \text{ GHz}}^{30 \text{ GHz}} \left(\frac{S_{inc,4cm,i}}{S_{inc,4cm,RL,i}} \right) \leq 1$$



2.2.7 Total Exposure Ratio (TER)

The total exposure ratio is the sum of local specific absorption rate (SAR), local absorbed power density (APD) and local incident power density (iPD) referenced in ICNIRP 2020:

where, SAR_i and SAR_{BR} are the local SAR level at frequency i and the local SAR basic restriction given in ICNIRP 2020. $S_{ab,4cm,i}$ and $S_{ab,4cm,BR}$ are the $4cm^2$ absorbed power density level at frequency i and the $4cm^2$ absorbed power density basic restriction given in ICNIRP 2020. $S_{inc,4cm,i}$ and $S_{inc,4cm,RL,i}$ are the local $4cm^2$ incident power density at frequency i and the local $4cm^2$ incident power density reference level at frequency i given in ICNIRP 2020.

$$\begin{aligned} & \sum_{i=100 \text{ kHz}}^{6 \text{ GHz}} \frac{SAR_i}{SAR_{BR}} \\ & + \sum_{i>6 \text{ GHz}}^{30 \text{ GHz}} \frac{S_{ab,4cm,i}}{S_{ab,4cm,BR}} \\ & + \sum_{i>6 \text{ GHz}}^{30 \text{ GHz}} \left(\frac{S_{inc,4cm,i}}{S_{inc,4cm,RL,i}} \right) \leq 1 \end{aligned}$$

TER is applied when simultaneous transmission of the different types of measurement is tested, and basic restriction limits cannot be applied. The TER of the applicable measurements is calculated and summed up to not exceed 1.



SECTION 3

TEST EQUIPMENT USED



3.1 TEST EQUIPMENT USED

The following test equipment was used at TÜV SÜD Product Service:

Instrument Description	Manufacturer	Model Type	TE Number	Cal Period (months)	Calibration Due Date
Thermometer	Fluke	-	2267	12	20-Feb-2024
Thermohygrometer	R.S Components	1364	6352	12	11-Jan-2024
Laptop Device Holder	Speag	MDA4LAP	4693	-	TU
Measurement server	Speag	DASY 6 Measurement Server	4692	-	TU
Mounting Platform	Speag	MP6C-TX90XL Mounting Platform Extended	4702	-	TU
Robot	Speag	TX90 XL Stäubli Robot	5340	-	TU
Measurement server	Speag	DASY 6 Measurement Server	5337	-	TU
Mounting Platform	Speag	MP6C-TX90XL Mounting Platform Extended	5338	-	TU
Robot	Speag	TX90 XL Stäubli Robot	4704	-	TU
Power Source for SAR system validation	Speag	POWERSOURCE1-SE UMS 160 BA	5371	12	12-Dec-2023
Body Phantom	Speag	ELI V8.0	4833	-	TU
Dielectric Assessment Kit	Speag	DAK 200MHz to 20GHz	4690	-	TU
Dielectric Probe Stand	Speag	Stand	4691	-	TU
Validation Dipole 2450MHz	Speag	D2450V2	3875	12	08-Dec-2023
Validation Dipole 5000MHz	Speag	D5.0 GHzV2	4309	12	14-Dec-2023
Validation Dipole 6500MHz	Speag	D6.5.0 GHzV2	6157	12	06-July-2024
10GHz Verification Source	Speag	5G Verification Source 10GHz	6449	12	27-Oct-2023
Signal Generator: 10MHz to 20GHz	Rohde & Schwarz	SMR20	3745	12	29-Jun-2024
Directional Coupler	Hewlett Packard	11692D	452	-	TU
Directional Coupler	Mini-Circuits	ZUDC20-06183-S+	6484	-	TU
ENA Series network analyser	Keysight Technologies	E5063A	5018	12	29-Sep-2023
EXA Signal Analyser	Keysight Technologies	N9010B	4968	12	19-Jan-2024



Instrument Description	Manufacturer	Model Type	TE Number	Cal Period (months)	Calibration Due Date
Attenuator (30dB)	Weinschel	46-30-34	2776	12	09-Aug-2024
Attenuator (10dB)	Aaren	AT40A-4041-D18-10	5493	12	18-Apr-2024
Amplifier	Mini-Circuits	ZVE-3W-183+	6540	-	TU
Power Sensor	Rohde & Schwarz	NRP-Z81	3492	12	13-Jan-2024
Power Meter	Rohde & Schwarz	NRP	3491	12	13-Jan-2024
Power Meter	Rohde & Schwarz	NRX	6535	12	05-Apr-2024
Power Sensor	Rohde & Schwarz	NRP18S	6534	12	17-Apr-2025
Power Sensor	Rohde & Schwarz	NRP18S	6533	12	17-Apr-2025
Data Acquisition	Speag	DAE4ip	6500	12	03-Apr-2024
Data Acquisition	Speag	DAE 4 - SD 000 D04 BM	4689	12	13-Dec-2023
Dosimetric SAR Probe	Speag	EX3DV4	4700	12	15-Dec-2023
PD probe	Speag	EUmmWV4	6353	12	25-Oct-2023
Tissue Simulant Liquid	Speag	HBBL 600-10000	Batch 1	-	Note 1

TU - Traceability Unscheduled

Note 1, the calibration dates for the relevant batches of TSL can be found in the fluid parameter tables within this report.



3.2 TEST SOFTWARE

The following software was used to control the TÜV SÜD Product Service DASY System.

Instrument	Version Number
DASY system	cDASY6 Module SAR V16.2.2.1588
DASY system	cDASY6 Module mmWave V3.2.0.1840



3.3 DIELECTRIC PROPERTIES OF SIMULANT LIQUIDS

The fluid properties of the simulant fluids used during routine SAR evaluation meet the dielectric properties required KDB 865664.

The dielectric properties of the tissue simulant liquids used are within the $\pm 10\%$ acceptance criteria for the SAR testing at TÜV SÜD Product Service and are as follows :-

Fluid Type and Frequency	Relative Permittivity Measured	Relative Permittivity Target	Conductivity Measured (S/m)	Conductivity Target (S/m)	Date	Fluid Temperature °C
HBBL/B1 - 2450MHz	39.52	39.20	1.82	1.80	16/08/2023	21.00
HBBL/B1 - 2450MHz	41.53	39.20	1.99	1.80	18/08/2023	19.00
HBBL/B1 - 2450MHz	42.15	39.20	1.89	1.80	18/08/2023	19.00
HBBL/B1 - 2450MHz	41.19	39.20	1.83	1.80	29/08/2023	21.40
HBBL/B1 - 5200MHz	36.25	35.98	4.66	4.65	23/08/2023	20.70
HBBL/B1 - 5200MHz	36.56	35.98	4.51	4.65	29/08/2023	21.40
HBBL/B1 - 5200MHz	36.38	35.98	4.60	4.65	31/08/2023	20.90
HBBL/B1 - 5500MHz	36.04	35.64	4.84	4.96	29/08/2023	21.40
HBBL/B1 - 5500MHz	35.82	35.64	4.93	4.96	31/08/2023	20.90
HBBL/B1 - 5600MHz	35.87	35.52	4.95	5.06	29/08/2023	21.40
HBBL/B1 - 5600MHz	35.64	35.52	5.05	5.06	31/08/2023	20.90
HBBL/B1 - 5800MHz	35.12	35.30	5.35	5.27	23/08/2023	20.70
HBBL/B1 - 5800MHz	34.95	35.30	5.30	5.27	25/08/2023	20.20
HBBL/B1 - 6500MHz	33.71	34.46	6.14	6.07	25/08/2023	20.20
HBBL/B1 - 6500MHz	34.91	35.07	5.53	5.47	31/09/2023	20.90
HBBL/B1 - 6500MHz	34.48	35.07	5.56	5.47	04/09/2023	19.90



3.4 TEST CONDITIONS

3.4.1 Test Laboratory Conditions

Ambient temperature: Within +18°C to +25°C.

The actual temperature during the testing ranged from 21.80°C to 20.00°C.

The actual humidity during the testing ranged from 38.40% to 68.70% RH.

The temperature of the fluid during testing does not deviate by more than 2°C for each set of tests.

3.4.2 Test Fluid Temperature Range

Frequency	Body / Head Fluid	Min Temperature °C	Max Temperature °C
2450 MHz	Head	19.30	21.50
5200 MHz	Head	19.90	21.40
5500 MHz	Head	19.00	21.40
5600 MHz	Head	20.03	21.40
5800 MHz	Head	19.90	21.20
6500 MHz	Head	19.60	20.70



3.5 MEASUREMENT UNCERTAINTY

Body, Full SAR Measurements, 300 MHz to 3 GHz

Source of Uncertainty	Uncertainty \pm %	Probability distribution	Div	c_i (1g)	Standard Uncertainty \pm % (1g)
Measurement System Errors					
Probe Calibration	12.0	Normal	2.00	1.00	6.0
Probe Calibration Drift	1.7	Rectangular	1.73	1.00	1.0
Probe Linearity	4.7	Rectangular	1.73	1.00	2.7
Broadband Signal	3.0	Rectangular	1.73	1.00	1.7
Probe Isotropy	7.6	Rectangular	1.73	1.00	4.4
Data Acquisition	0.3	Normal	1.00	1.00	0.3
RF Ambient	1.8	Normal	1.00	1.00	1.8
Probe Positioning	0.2	Normal	1.00	0.14	0.0
Data Processing	1.2	Normal	1.00	1.00	1.2
Phantom and Device errors					
Liquid Conductivity Meas.	2.5	Normal	1.00	0.78	2.0
Liquid Conductivity Temp	3.3	Rectangular	1.73	0.78	1.5
Phantom Permittivity	14.0	Rectangular	1.73	0.00	0.0
Distance DUT - TSL	2.0	Normal	1.00	2.00	4.0
Device Positioning (± 0.5 mm)	1.0	Normal	1.00	1.00	1.0
Device Holder	3.6	Normal	1.00	1.00	3.6
Device Modulation	2.4	Rectangular	1.73	1.00	1.4
Time-average SAR	2.6	Rectangular	1.73	1.00	1.5
DUT Drift	5.0	Normal	1.00	1.00	5.0
Correction to the SAR results					
Deviation to Target	1.9	Normal	1.00	1.00	1.9
SAR Scaling	0.0	Rectangular	1.73	1.00	0.0
Combined Standard Uncertainty		RSS			11.8
Expanded Standard Uncertainty		K=2			23.7



Body, Full SAR Measurements, 3 GHz to 6 GHz

Source of Uncertainty	Uncertainty ± %	Probability distribution	Div	c _i (1g)	Standard Uncertainty ± % (1g)
Measurement System Errors					
Probe Calibration	14.0	Normal	2.00	1.00	7.0
Probe Calibration Drift	1.7	Rectangular	1.73	1.00	1.0
Probe Linearity	4.7	Rectangular	1.73	1.00	2.7
Broadband Signal	2.6	Rectangular	1.73	1.00	1.5
Probe Isotropy	7.6	Rectangular	1.73	1.00	4.4
Data Acquisition	0.3	Normal	1.00	1.00	0.3
RF Ambient	1.8	Normal	1.00	1.00	1.8
Probe Positioning	0.2	Normal	1.00	0.33	0.1
Data Processing	2.3	Normal	1.00	1.00	2.3
Phantom and Device errors					
Liquid Conductivity Meas.	2.5	Normal	1.00	0.78	2.0
Liquid Conductivity Temp	3.4	Rectangular	1.73	0.78	1.5
Phantom Permittivity	14.0	Rectangular	1.73	0.25	2.0
Distance DUT - TSL	2.0	Normal	1.00	2.00	4.0
Device Positioning (±0.5mm)	1.0	Normal	1.00	1.00	1.0
Device Holder	3.6	Normal	1.00	1.00	3.6
Device Modulation	2.4	Rectangular	1.73	1.00	1.4
Time-average SAR	2.6	Rectangular	1.73	1.00	1.5
DUT Drift	5.0	Normal	1.00	1.00	5.0
Correction to the SAR results					
Deviation to Target	1.9	Normal	1.00	1.00	1.9
SAR Scaling	0.0	Rectangular	1.73	1.00	0.0
Combined Standard Uncertainty		RSS			12.7
Expanded Standard Uncertainty		K=2			25.3



Body, Full SAR Measurements, 6 GHz to 10 GHz

Source of Uncertainty	Uncertainty ± %	Probability distribution	Div	c _i (1g)	Standard Uncertainty ± % (1g)
Measurement System Errors					
Probe Calibration	18.6	Normal	2.00	1.00	9.3
Probe Calibration Drift	1.7	Rectangular	1.73	1.00	1.0
Probe Linearity	4.7	Rectangular	1.73	1.00	2.7
Broadband Signal	2.8	Rectangular	1.73	1.00	1.6
Probe Isotropy	7.6	Rectangular	1.73	1.00	4.4
Data Acquisition	0.3	Normal	1.00	1.00	0.3
RF Ambient	1.8	Normal	1.00	1.00	1.8
Probe Positioning	0.2	Normal	1.00	0.67	0.1
Data Processing	3.5	Normal	1.00	1.00	3.5
Phantom and Device errors					
Liquid Conductivity Meas.	2.5	Normal	1.00	0.78	2.0
Liquid Conductivity Temp	2.4	Rectangular	1.73	0.78	1.1
Phantom Permittivity	14.0	Rectangular	1.73	0.50	4.0
Distance DUT - TSL	2.0	Normal	1.00	2.00	4.0
Device Positioning (±0.5mm)	1.0	Normal	1.00	1.00	1.0
Device Holder	3.6	Normal	1.00	1.00	3.6
Device Modulation	2.4	Rectangular	1.73	1.00	1.4
Time-average SAR	2.6	Rectangular	1.73	1.00	1.5
DUT Drift	5.0	Normal	1.00	1.00	5.0
Correction to the SAR results					
Deviation to Target	1.9	Normal	1.00	1.00	1.9
SAR Scaling	0.0	Rectangular	1.73	1.00	0.0
Combined Standard Uncertainty		RSS			14.7
Expanded Standard Uncertainty		K=2			29.4



Body, Full APD Measurements, 6 GHz to 10 GHz

Symbol	Error Description	Value %	Probability distribution	Divisor	c_i (1 g)	Std Uncertainty (1 g)	c_i (10 g)	Std Uncertainty (10 g)
Measurement System Errors								
<i>CF</i>	Probe Calibration	18.60	normal 2	2.000	1	9.30	1	9.30
<i>CF_{DRIFT}</i>	Probe Calibration Drift	1.70	rectangular	1.732	1	0.98	1	0.98
<i>LIN</i>	Probe Linearity	4.70	rectangular	1.732	1	2.71	1	2.71
<i>BBS</i>	Broadband Signal	2.80	rectangular	1.732	1	1.62	1	1.62
<i>ISO</i>	Probe Isotropy	7.60	rectangular	1.732	1	4.39	1	4.39
<i>DAE</i>	Other Probe+Electronic	0.30	normal 1	1.000	1	0.30	1	0.30
<i>DAE</i>	Boundary Effects + Corrections	4.00	rectangular	1.732	1	2.31	1	2.31
<i>DAE</i>	Sensor Offset & Uncertainty	0.10	normal 1	1.000	1	0.10	1	0.10
<i>AMB</i>	RF Ambient	3.00	normal 1	1.000	1	3.00	1	3.00
Δ_{sys}	Probe Positioning	0.01	normal 1	1.000	0.5	0.00	0.5	0.00
<i>DAT</i>	Data Processing	1.00	rectangular	1.732	1	0.58	1	0.58
Phantom and Device Errors								
<i>LIQ(σ)</i>	Conductivity (meas) ^{DAK}	2.50	normal 1	1.000	0.78	1.95	0.71	1.78
<i>LIQ($T\sigma$)</i>	Conductivity (temp) ^{BB}	2.40	rectangular	1.732	0.78	1.08	0.71	0.98
<i>EPS</i>	Phantom Permittivity	14.00	rectangular	1.732	0.5	4.04	0.5	4.04
<i>DIS</i>	Distance DUT – TSL	2.00	normal 1	1.000	2	4.00	2	4.00
<i>Dxyz</i>	Device Positioning	1.00	normal 1	1.000	1	1.00	1	1.00
<i>H</i>	Device Holder	3.60	normal 1	1.000	1	3.60	1	3.60
<i>MOD</i>	DUT Modulation ^m	2.40	rectangular	1.732	1	1.39	1	1.39
<i>TAS</i>	Time-average SAR	1.70	rectangular	1.732	1	0.98	1	0.98
<i>Rfdrift</i>	DUT drift	5.00	normal 1	1.000	1	5.00	1	5.00
<i>VAL</i>	Val Antenna Unc. ^{val}	0.00	normal 1	1.000	1	0.00	1	0.00
<i>Rfin</i>	Unc. Input Power ^{val}	0.00	normal 1	1.000	1	0.00	1	0.00
Correction To The SAR Results								
<i>C(ϵ, σ)</i>	Deviation to Target	1.90	normal 1	1.000	1	1.90	0.84	1.60
<i>C(R)</i>	SAR scaling	0.00	rectangular	1.732	1	0.00	1	0.00
APD								
<i>PDC</i>	Power Density Conversion	13.50	rectangular	1.732	1	7.79	1	7.79
<i>u(ΔSAR)</i>	Combined Standard Uncertainty	-	normal	-	-	16.58	-	16.52
<i>U</i>	Expanded Uncertainty	-	normal k =	2.00	-	33.2	-	33



DASY6 Uncertainty Budget for iPD

Symbol	Error Description	Value dB	Probability distribution	Divisor	c_i	$u_i(y)$ dB	$(u_i(y))^2$	v_i or v_{eff}	$u_i^4(y)$
Uncertainty terms dependent on the measurement system									
CAL	Calibration	0.49	normal 1	1.000	1	0.49	0.240	∞	0
COR	Probe correction	0.00	rectangular	1.732	1	0.00	0.000	∞	0
FRS	Frequency response (BW \leq 1 GHz)	0.20	rectangular	1.732	1	0.12	0.013	∞	0
SCC	Sensor cross coupling	0.00	rectangular	1.732	1	0.00	0.000	∞	0
ISO	Isotropy	0.50	rectangular	1.732	1	0.29	0.083	∞	0
LIN	Linearity	0.20	rectangular	1.732	1	0.12	0.013	∞	0
PSC	Probe scattering	0.00	rectangular	1.732	1	0.00	0.000	∞	0
PPO	Probe positioning offset	0.30	rectangular	1.732	1	0.17	0.030	∞	0
PPR	Probe positioning repeatability	0.04	rectangular	1.732	1	0.02	0.001	∞	0
SMO	Sensor mechanical offset	0.00	rectangular	1.732	1	0.00	0.000	∞	0
PSR	Probe spatial resolution	0.00	rectangular	1.732	1	0.00	0.000	∞	0
FLD	Field impedance dependence	0.00	rectangular	1.732	1	0.00	0.000	∞	0
APD	Amplitude and phase drift	0.00	rectangular	1.732	1	0.00	0.000	∞	0
APN	Amplitude and phase noise	0.04	rectangular	1.732	1	0.02	0.001	∞	0
TR	Measurement area truncation	0.00	rectangular	1.732	1	0.00	0.000	∞	0
DAQ	Data acquisition	0.03	normal 1	1.000	1	0.03	0.001	∞	0
SMP	Sampling	0.00	rectangular	1.732	1	0.00	0.000	∞	0
REC	Field reconstruction	0.60	rectangular	1.732	1	0.35	0.120	∞	0
TRA	FTE/MEO	0.70	rectangular	1.732	1	0.40	0.163	∞	0
SCA	Power density scaling	0.00	rectangular	1.732	1	0.00	0.000	∞	0
SAV	Spatial averaging	0.10	rectangular	1.732	1	0.06	0.003	∞	0
SDL	System detection limit	0.04	rectangular	1.732	1	0.02	0.001	∞	0
Uncertainty terms dependent on the DUT and environmental factors									
PC	Probe coupling with DUT	0.00	rectangular	1.732	1	0.00	0.000	∞	0
MOD	Modulation response	0.40	rectangular	1.732	1	0.23	0.053	∞	0
IT	Integration time	0.00	rectangular	1.732	1	0.00	0.000	∞	0
RT	Response time	0.00	rectangular	1.732	1	0.00	0.000	∞	0
DH	Device holder influence	0.10	rectangular	1.732	1	0.06	0.003	∞	0
DA	DUT alignment	0.00	rectangular	1.732	1	0.00	0.000	∞	0
REF	Reflections in laboratory	0.10	rectangular	1.732	1	0.06	0.003	∞	0
TEM	Laboratory temperature	0.10	rectangular	1.732	1	0.06	0.003	∞	0
AC	RF ambient conditions	0.04	rectangular	1.732	1	0.02	0.001	∞	0
AR	Ambient reflections	0.04	rectangular	1.732	1	0.02	0.001	∞	0
MSI	Immunity / secondary reception	0.00	rectangular	1.732	1	0.00	0.000	∞	0
DRI	Drift of the DUT	0.00	rectangular	1.732	1	0.00	0.000	∞	0
$u_c(F_s)$	Combined Standard Uncertainty (w/ FTE/MEO)	-	normal	-	-	0.86	0.734	∞	0
$U(F_s)$	Expanded Uncertainty (w/ FTE/MEO)	-	normal k =	2.00	-	1.7	-	∞	-



DASY6 mmWave Uncertainty Budget - System Performance Check

Symbol	Error Description	Value dB	Probability distribution	Divisor	c_i	$u_i(y)$ dB	$(u_i(y))^2$ dB	v_i or v_{eff}	$u_i^4(y)$
Uncertainty terms dependent on the measurement system									
CAL	Calibration Repeatability	0.21	normal 1	1.000	1	0.21	0.044	∞	0
COR	Probe correction	0.00	rectangular	1.732	1	0.00	0.000	∞	0
FRS	Frequency response (BW \leq 1 GHz)	0.20	rectangular	1.732	0	0.00	0.000	∞	0
SCC	Sensor cross coupling	0.00	rectangular	1.732	1	0.00	0.000	∞	0
ISO	Isotropy	0.30	rectangular	1.732	1	0.17	0.030	∞	0
LIN	Linearity	0.20	rectangular	1.732	1	0.12	0.013	∞	0
PSC	Probe scattering	0.00	rectangular	1.732	1	0.00	0.000	∞	0
PPO	Probe positioning offset	0.11	rectangular	1.732	1	0.06	0.004	∞	0
PPR	Probe positioning repeatability	0.04	rectangular	1.732	1	0.02	0.001	∞	0
SMO	Sensor mechanical offset	0.00	rectangular	1.732	1	0.00	0.000	∞	0
PSR	Probe spatial resolution	0.00	rectangular	1.732	1	0.00	0.000	∞	0
FLD	Field impedance dependence	0.00	rectangular	1.732	1	0.00	0.000	∞	0
APD	Amplitude and phase drift	0.00	rectangular	1.732	1	0.00	0.000	∞	0
APN	Amplitude and phase noise	0.04	rectangular	1.732	0	0.00	0.000	∞	0
TR	Measurement area truncation	0.00	rectangular	1.732	1	0.00	0.000	∞	0
DAQ	Data acquisition	0.03	normal 1	1.000	1	0.03	0.001	∞	0
SMP	Sampling	0.00	rectangular	1.732	1	0.00	0.000	∞	0
REC	Field reconstruction	0.60	rectangular	1.732	0.3	0.10	0.011	∞	0
TRA	Forward transformation	0.00	rectangular	1.732	1	0.00	0.000	∞	0
SCA	Power density scaling	0.00	rectangular	1.732	1	0.00	0.000	∞	0
SAV	Spatial averaging	0.10	rectangular	1.732	0	0.00	0.000	∞	0
SDL	System detection limit	0.04	rectangular	1.732	1	0.02	0.001	∞	0
Uncertainty terms dependent on the DUT and environmental factors									
PC	Probe coupling with DUT	0.00	rectangular	1.732	1	0.00	0.000	∞	0
MOD	Modulation response	0.40	rectangular	1.732	0	0.00	0.000	∞	0
IT	Integration time	0.00	rectangular	1.732	1	0.00	0.000	∞	0
RT	Response time	0.00	rectangular	1.732	1	0.00	0.000	∞	0
DH	Device holder influence	0.10	rectangular	1.732	0	0.00	0.000	∞	0
REF	Reflections in laboratory	0.10	rectangular	1.732	1	0.06	0.003	∞	0
TEM	Laboratory temperature	0.10	rectangular	1.732	1	0.06	0.003	∞	0
DA	DUT alignment	0.00	rectangular	1.732	1	0.00	0.000	∞	0
AC	RF ambient conditions	0.04	rectangular	1.732	1	0.02	0.001	∞	0
AR	Ambient reflections	0.04	rectangular	1.732	1	0.02	0.001	∞	0
MSI	Immunity / secondary reception	0.00	rectangular	1.732	0	0.00	0.000	∞	0
DRI	Drift of the DUT	0.10	rectangular	1.732	1	0.06	0.003	∞	0
$u_c(F_s)$	Combined Standard Uncertainty (w/ FTE/MEO)	-	normal	-	-	0.34	0.115	∞	0
$U(F_s)$	Expanded Uncertainty (w/ FTE/MEO)	-	normal k =	2.00	-	0.7		∞	-



Decision Rule - Accuracy Method

Determination of conformity with the specification limits is based on the decision rule according to IEC Guide 115:2007, Clause 4.4.3 and 4.5.1. (Procedure 2). The measurement results are directly compared with the test limit to determine conformance with the requirements of the standard.

Risk: The uncertainty of measurement about the measured result is negligible with regard to the final pass/fail decision. The measurement result can be directly compared with the test limit to determine conformance with the requirement (compare IEC Guide 115). The level of risk to falsely accept and falsely reject items is further described in ILAC-G8.”



SECTION 4

ACCREDITATION, DISCLAIMERS AND COPYRIGHT



4.1 ACCREDITATION, DISCLAIMERS AND COPYRIGHT



This report relates only to the actual item/items tested.

Our UKAS Accreditation does not cover opinions and interpretations and any expressed are outside the scope of our UKAS Accreditation.

Results of tests not covered by our UKAS Accreditation Schedule are marked NUA (Not UKAS Accredited).

This report must not be reproduced, except in its entirety, without the written permission of TÜV SÜD Product Service

© 2023 TÜV SÜD Product Service



ANNEX A

PROBE CALIBRATION REPORT



Calibration Laboratory of
Schmid & Partner
Engineering AG
 Zeughausstrasse 43, 8004 Zurich, Switzerland



S Schweizerischer Kalibrierdienst
C Service suisse d'étalonnage
S Servizio svizzero di taratura
S Swiss Calibration Service

Accredited by the Swiss Accreditation Service (SAS)
 The Swiss Accreditation Service is one of the signatories to the EA
 Multilateral Agreement for the recognition of calibration certificates

Accreditation No.: **SCS 0108**

Client **TÜV SÜD UK**

Certificate No **EX-3759_Dec22**

CALIBRATION CERTIFICATE

Object **EX3DV4 - SN:3759**

Calibration procedure(s) **QA CAL-01.v10, QA CAL-12.v10, QA CAL-14.v7, QA CAL-23.v6, QA CAL-25.v8
 Calibration procedure for dosimetric E-field probes**

Calibration date **December 15, 2022**

This calibration certificate documents the traceability to national standards, which realize the physical units of measurements (SI). The measurements and the uncertainties with confidence probability are given on the following pages and are part of the certificate.

All calibrations have been conducted in the closed laboratory facility: environment temperature (22 ± 3) °C and humidity < 70%.

Calibration Equipment used (M&TE critical for calibration)

Primary Standards	ID	Cal Date (Certificate No.)	Scheduled Calibration
Power meter NRP	SN: 104778	04-Apr-22 (No. 217-03525/03524)	Apr-23
Power sensor NRP-Z91	SN: 103244	04-Apr-22 (No. 217-03524)	Apr-23
OCP DAK-3.5 (weighted)	SN: 1249	20-Oct-22 (OCP-DAK3.5-1249_Oct22)	Oct-23
OCP DAK-12	SN: 1016	20-Oct-22 (OCP-DAK12-1016_Oct22)	Oct-23
Reference 20 dB Attenuator	SN: CC2552 (20x)	04-Apr-22 (No. 217-03527)	Apr-23
DAE4	SN: 660	10-Oct-22 (No. DAE4-660_Oct22)	Oct-23
Reference Probe ES3DV2	SN: 3013	27-Dec-21 (No. ES3-3013_Dec21)	Dec-22

Secondary Standards	ID	Check Date (in house)	Scheduled Check
Power meter E4419B	SN: GB41293874	06-Apr-16 (in house check Jun-22)	In house check: Jun-24
Power sensor E4412A	SN: MY41498087	06-Apr-16 (in house check Jun-22)	In house check: Jun-24
Power sensor E4412A	SN: 000110210	06-Apr-16 (in house check Jun-22)	In house check: Jun-24
RF generator HP 8648C	SN: US3642U01700	04-Aug-99 (in house check Jun-22)	In house check: Jun-24
Network Analyzer E8358A	SN: US41080477	31-Mar-14 (in house check Oct-22)	In house check: Oct-24

	Name	Function	Signature
Calibrated by	Jeton Kastrati	Laboratory Technician	
Approved by	Sven Kühn	Technical Manager	

Issued: December 16, 2022

This calibration certificate shall not be reproduced except in full without written approval of the laboratory.



Calibration Laboratory of

Schmid & Partner
Engineering AG

Zeughausstrasse 43, 8004 Zurich, Switzerland



S Schweizerischer Kalibrierdienst
C Service suisse d'étalonnage
S Servizio svizzero di taratura
S Swiss Calibration Service

Accredited by the Swiss Accreditation Service (SAS)

The Swiss Accreditation Service is one of the signatories to the EA Multilateral Agreement for the recognition of calibration certificates

Accreditation No.: SCS 0108

Glossary

TSL	tissue simulating liquid
NORM _{x,y,z}	sensitivity in free space
ConvF	sensitivity in TSL / NORM _{x,y,z}
DCP	diode compression point
CF	crest factor (1/duty_cycle) of the RF signal
A, B, C, D	modulation dependent linearization parameters
Polarization φ	φ rotation around probe axis
Polarization θ	θ rotation around an axis that is in the plane normal to probe axis (at measurement center), i.e., $\theta = 0$ is normal to probe axis
Connector Angle	information used in DASY system to align probe sensor X to the robot coordinate system

Calibration is Performed According to the Following Standards:

- IEC/IEEE 62209-1528, "Measurement Procedure For The Assessment Of Specific Absorption Rate Of Human Exposure To Radio Frequency Fields From Hand-Held And Body-Worn Wireless Communication Devices – Part 1528: Human Models, Instrumentation And Procedures (Frequency Range of 4 MHz to 10 GHz)", October 2020.
- KDB 865664, "SAR Measurement Requirements for 100 MHz to 6 GHz"

Methods Applied and Interpretation of Parameters:

- NORM_{x,y,z}**: Assessed for E-field polarization $\theta = 0$ ($f \leq 900$ MHz in TEM-cell; $f > 1800$ MHz: R22 waveguide). NORM_{x,y,z} are only intermediate values, i.e., the uncertainties of NORM_{x,y,z} does not affect the E²-field uncertainty inside TSL (see below ConvF).
- NORM(f)_{x,y,z} = NORM_{x,y,z} * frequency_response** (see Frequency Response Chart). This linearization is implemented in DASY4 software versions later than 4.2. The uncertainty of the frequency response is included in the stated uncertainty of ConvF.
- DCP_{x,y,z}**: DCP are numerical linearization parameters assessed based on the data of power sweep with CW signal. DCP does not depend on frequency nor media.
- PAR**: PAR is the Peak to Average Ratio that is not calibrated but determined based on the signal characteristics
- A_{x,y,z}; B_{x,y,z}; C_{x,y,z}; D_{x,y,z}; VR_{x,y,z}**: A, B, C, D are numerical linearization parameters assessed based on the data of power sweep for specific modulation signal. The parameters do not depend on frequency nor media. VR is the maximum calibration range expressed in RMS voltage across the diode.
- ConvF and Boundary Effect Parameters**: Assessed in flat phantom using E-field (or Temperature Transfer Standard for $f \leq 800$ MHz) and inside waveguide using analytical field distributions based on power measurements for $f > 800$ MHz. The same setups are used for assessment of the parameters applied for boundary compensation (alpha, depth) of which typical uncertainty values are given. These parameters are used in DASY4 software to improve probe accuracy close to the boundary. The sensitivity in TSL corresponds to NORM_{x,y,z} * ConvF whereby the uncertainty corresponds to that given for ConvF. A frequency dependent ConvF is used in DASY version 4.4 and higher which allows extending the validity from ± 50 MHz to ± 100 MHz.
- Spherical isotropy (3D deviation from isotropy)**: in a field of low gradients realized using a flat phantom exposed by a patch antenna.
- Sensor Offset**: The sensor offset corresponds to the offset of virtual measurement center from the probe tip (on probe axis). No tolerance required.
- Connector Angle**: The angle is assessed using the information gained by determining the NORM_x (no uncertainty required).



EX3DV4 - SN:3759

December 15, 2022

Parameters of Probe: EX3DV4 - SN:3759

Basic Calibration Parameters

	Sensor X	Sensor Y	Sensor Z	Unc (k = 2)
Norm ($\mu\text{V}/(\text{V}/\text{m}^2)$) ^A	0.51	0.47	0.51	±10.1%
DCP (mV) ^B	98.8	99.9	100.7	±4.7%

Calibration Results for Modulation Response

UID	Communication System Name		A dB	B dB $\sqrt{\mu\text{V}}$	C	D dB	VR mV	Max dev.	Max Unc ^E k = 2
0	CW	X	0.00	0.00	1.00	0.00	162.5	±2.7%	±4.7%
		Y	0.00	0.00	1.00		155.7		
		Z	0.00	0.00	1.00		156.6		
10352	Pulse Waveform (200Hz, 10%)	X	60.00	106.00	25.00	10.00	60.0	±3.1%	±9.6%
		Y	20.00	90.79	20.60		60.0		
		Z	20.00	92.14	21.63		60.0		
10353	Pulse Waveform (200Hz, 20%)	X	20.00	93.93	20.98	6.99	80.0	±1.8%	±9.6%
		Y	20.00	91.80	20.19		80.0		
		Z	20.00	93.65	21.18		80.0		
10354	Pulse Waveform (200Hz, 40%)	X	20.00	96.67	20.80	3.98	95.0	±1.0%	±9.6%
		Y	20.00	94.72	20.39		95.0		
		Z	20.00	97.08	21.27		95.0		
10355	Pulse Waveform (200Hz, 60%)	X	20.00	96.83	19.43	2.22	120.0	±1.1%	±9.6%
		Y	20.00	97.70	20.53		120.0		
		Z	20.00	99.49	20.80		120.0		
10387	QPSK Waveform, 1 MHz	X	1.47	64.12	13.54	1.00	150.0	±2.9%	±9.6%
		Y	1.57	64.74	14.09		150.0		
		Z	1.66	66.53	15.01		150.0		
10388	QPSK Waveform, 10 MHz	X	1.95	65.80	14.33	0.00	150.0	±1.1%	±9.6%
		Y	2.06	66.52	14.80		150.0		
		Z	2.25	68.56	15.86		150.0		
10396	64-QAM Waveform, 100 kHz	X	2.81	69.07	17.97	3.01	150.0	±0.8%	±9.6%
		Y	3.08	71.15	19.10		150.0		
		Z	2.86	69.56	18.45		150.0		
10399	64-QAM Waveform, 40 MHz	X	3.31	66.06	15.06	0.00	150.0	±2.4%	±9.6%
		Y	3.40	66.45	15.31		150.0		
		Z	3.54	67.47	15.91		150.0		
10414	WLAN CCDF, 64-QAM, 40 MHz	X	4.73	65.09	15.14	0.00	150.0	±4.1%	±9.6%
		Y	4.80	65.28	15.26		150.0		
		Z	4.92	65.97	15.70		150.0		

Note: For details on UID parameters see Appendix

The reported uncertainty of measurement is stated as the standard uncertainty of measurement multiplied by the coverage factor k=2, which for a normal distribution corresponds to a coverage probability of approximately 95%.

^A The uncertainties of Norm X,Y,Z do not affect the E²-field uncertainty inside TSL (see Pages 5 to 7).

^B Linearization parameter uncertainty for maximum specified field strength.

^E Uncertainty is determined using the max. deviation from linear response applying rectangular distribution and is expressed for the square of the field value.



EX3DV4 - SN:3759

December 15, 2022

Parameters of Probe: EX3DV4 - SN:3759

Sensor Model Parameters

	C1 fF	C2 fF	α V ⁻¹	T1 ms V ⁻²	T2 ms V ⁻¹	T3 ms	T4 V ⁻²	T5 V ⁻¹	T6
x	45.1	340.04	35.95	13.08	0.22	5.10	0.78	0.38	1.01
y	46.9	350.37	35.41	20.47	0.00	5.10	1.51	0.23	1.01
z	46.0	344.77	35.86	15.05	0.48	5.10	0.17	0.51	1.01

Other Probe Parameters

Sensor Arrangement	Triangular
Connector Angle	-70.2°
Mechanical Surface Detection Mode	enabled
Optical Surface Detection Mode	disabled
Probe Overall Length	337 mm
Probe Body Diameter	10 mm
Tip Length	9 mm
Tip Diameter	2.5 mm
Probe Tip to Sensor X Calibration Point	1 mm
Probe Tip to Sensor Y Calibration Point	1 mm
Probe Tip to Sensor Z Calibration Point	1 mm
Recommended Measurement Distance from Surface	1.4 mm

Note: Measurement distance from surface can be increased to 3–4 mm for an *Area Scan* job.



EX3DV4 - SN:3759

December 15, 2022

Parameters of Probe: EX3DV4 - SN:3759

Calibration Parameter Determined in Head Tissue Simulating Media

f (MHz) ^C	Relative Permittivity ^F	Conductivity ^F (S/m)	ConvF X	ConvF Y	ConvF Z	Alpha ^G	Depth ^G (mm)	Unc (k = 2)
30	55.0	0.75	15.75	15.75	15.75	0.00	1.00	±13.3%
64	54.2	0.75	13.77	13.77	13.77	0.00	1.00	±13.3%
128	52.8	0.76	12.39	12.39	12.39	0.00	1.00	±13.3%
150	52.3	0.76	12.13	12.13	12.13	0.00	1.00	±13.3%
220	49.0	0.81	11.74	11.74	11.74	0.00	1.00	±13.3%
300	45.3	0.87	11.57	11.57	11.57	0.09	1.00	±13.3%
450	43.5	0.87	10.83	10.83	10.83	0.16	1.30	±13.3%
750	41.9	0.89	9.64	9.64	9.64	0.58	0.91	±12.0%
835	41.5	0.90	9.50	9.50	9.50	0.33	1.10	±12.0%
900	41.5	0.97	9.25	9.25	9.25	0.53	0.80	±12.0%
1300	40.8	1.14	8.99	8.99	8.99	0.36	1.09	±12.0%
1450	40.5	1.20	8.84	8.84	8.84	0.42	0.80	±12.0%
1640	40.2	1.31	8.73	8.73	8.73	0.32	0.86	±12.0%
1750	40.1	1.37	8.67	8.67	8.67	0.36	0.86	±12.0%
1810	40.0	1.40	8.51	8.51	8.51	0.35	0.86	±12.0%
1900	40.0	1.40	8.24	8.24	8.24	0.39	0.86	±12.0%
1950	40.0	1.40	8.23	8.23	8.23	0.35	0.86	±12.0%
2000	40.0	1.40	8.20	8.20	8.20	0.34	0.86	±12.0%
2100	39.8	1.49	8.16	8.16	8.16	0.40	0.86	±12.0%
2300	39.5	1.67	8.10	8.10	8.10	0.30	0.90	±12.0%
2450	39.2	1.80	7.76	7.76	7.76	0.35	0.90	±12.0%
2550	39.1	1.91	7.60	7.60	7.60	0.34	0.90	±12.0%
2600	39.0	1.96	7.50	7.50	7.50	0.34	0.90	±12.0%
3300	38.2	2.71	7.18	7.18	7.18	0.35	1.30	±13.1%
3500	37.9	2.91	7.15	7.15	7.15	0.35	1.35	±13.1%
3700	37.7	3.12	6.90	6.90	6.90	0.35	1.35	±13.1%
4100	37.2	3.53	6.63	6.63	6.63	0.40	1.60	±13.1%
5200	36.0	4.66	5.75	5.75	5.75	0.40	1.80	±13.1%

^C Frequency validity above 300 MHz of ±100 MHz only applies for DASY v4.4 and higher (see Page 2), else it is restricted to ±50 MHz. The uncertainty is the RSS of the ConvF uncertainty at calibration frequency and the uncertainty for the indicated frequency band. Frequency validity below 300 MHz is ±10, 25, 40, 50 and 70 MHz for ConvF assessments at 30, 64, 128, 150 and 220 MHz respectively. Validity of ConvF assessed at 6 MHz is 4–9 MHz, and ConvF assessed at 13 MHz is 9–19 MHz. Above 5 GHz frequency validity can be extended to ±110 MHz.

^F At frequencies below 3 GHz, the validity of tissue parameters (ϵ and σ) can be relaxed to ±10% if liquid compensation formula is applied to measured SAR values. At frequencies above 3 GHz, the validity of tissue parameters (ϵ and σ) is restricted to ±5%. The uncertainty is the RSS of the ConvF uncertainty for indicated target tissue parameters.

^G Alpha/Depth are determined during calibration. SPEAG warrants that the remaining deviation due to the boundary effect after compensation is always less than ±1% for frequencies below 3 GHz and below ±2% for frequencies between 3–6 GHz at any distance larger than half the probe tip diameter from the boundary.



EX3DV4 - SN:3759

December 15, 2022

Parameters of Probe: EX3DV4 - SN:3759

Calibration Parameter Determined in Head Tissue Simulating Media

f (MHz) ^C	Relative Permittivity ^F	Conductivity ^F (S/m)	ConvF X	ConvF Y	ConvF Z	Alpha ^G	Depth ^G (mm)	Unc (k = 2)
5300	35.9	4.76	5.58	5.58	5.58	0.40	1.80	±13.1%
5500	35.6	4.96	5.20	5.20	5.20	0.40	1.80	±13.1%
5600	35.5	5.07	5.10	5.10	5.10	0.40	1.80	±13.1%
5800	35.3	5.27	5.12	5.12	5.12	0.40	1.80	±13.1%

^C Frequency validity above 300 MHz of ±100 MHz only applies for DASY v4.4 and higher (see Page 2), else it is restricted to ±50 MHz. The uncertainty is the RSS of the ConvF uncertainty at calibration frequency and the uncertainty for the indicated frequency band. Frequency validity below 300 MHz is ±10, 25, 40, 50 and 70 MHz for ConvF assessments at 30, 64, 128, 150 and 220 MHz respectively. Validity of ConvF assessed at 6 MHz is 4–9 MHz, and ConvF assessed at 13 MHz is 9–19 MHz. Above 5 GHz frequency validity can be extended to ±110 MHz.

^F At frequencies below 3 GHz, the validity of tissue parameters (ϵ and σ) can be relaxed to ±10% if liquid compensation formula is applied to measured SAR values. At frequencies above 3 GHz, the validity of tissue parameters (ϵ and σ) is restricted to ±5%. The uncertainty is the RSS of the ConvF uncertainty for indicated target tissue parameters.

^G Alpha/Depth are determined during calibration. SPEAG warrants that the remaining deviation due to the boundary effect after compensation is always less than ±1% for frequencies below 3 GHz and below ±2% for frequencies between 3–6 GHz at any distance larger than half the probe tip diameter from the boundary.



EX3DV4 - SN:3759

December 15, 2022

Parameters of Probe: EX3DV4 - SN:3759

Calibration Parameter Determined in Head Tissue Simulating Media

f (MHz) ^C	Relative Permittivity ^F	Conductivity ^F (S/m)	ConvF X	ConvF Y	ConvF Z	Alpha ^G	Depth ^G (mm)	Unc (k = 2)
6500	34.5	6.07	5.50	5.50	5.50	0.20	2.50	±18.6%

^C Frequency validity at 6.5 GHz is -600/+700 MHz, and ±700 MHz at or above 7 GHz. The uncertainty is the RSS of the ConvF uncertainty at calibration frequency and the uncertainty for the indicated frequency band.

^F At frequencies 6–10 GHz, the validity of tissue parameters (ϵ and σ) can be relaxed to ±10% if liquid compensation formula is applied to measured SAR values. The uncertainty is the RSS of the ConvF uncertainty for indicated target tissue parameters.

^G Alpha/Depth are determined during calibration. SPEAG warrants that the remaining deviation due to the boundary effect after compensation is always less than ±1% for frequencies below 3 GHz; below ±2% for frequencies between 3–6 GHz; and below ±4% for frequencies between 6–10 GHz at any distance larger than half the probe tip diameter from the boundary.



EX3DV4 - SN:3759

December 15, 2022

Frequency Response of E-Field

(TEM-Cell:ifi110 EXX, Waveguide:R22)

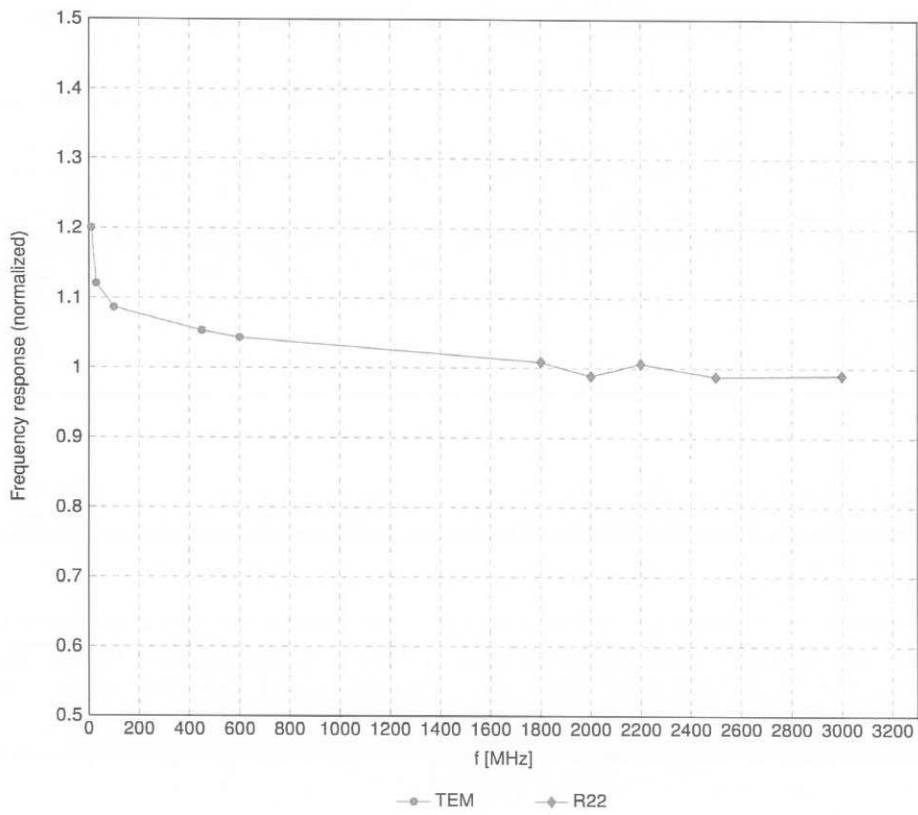

Uncertainty of Frequency Response of E-field: $\pm 6.3\%$ (k=2)



EX3DV4 - SN:3759

December 15, 2022

Receiving Pattern (ϕ), $\vartheta = 0^\circ$

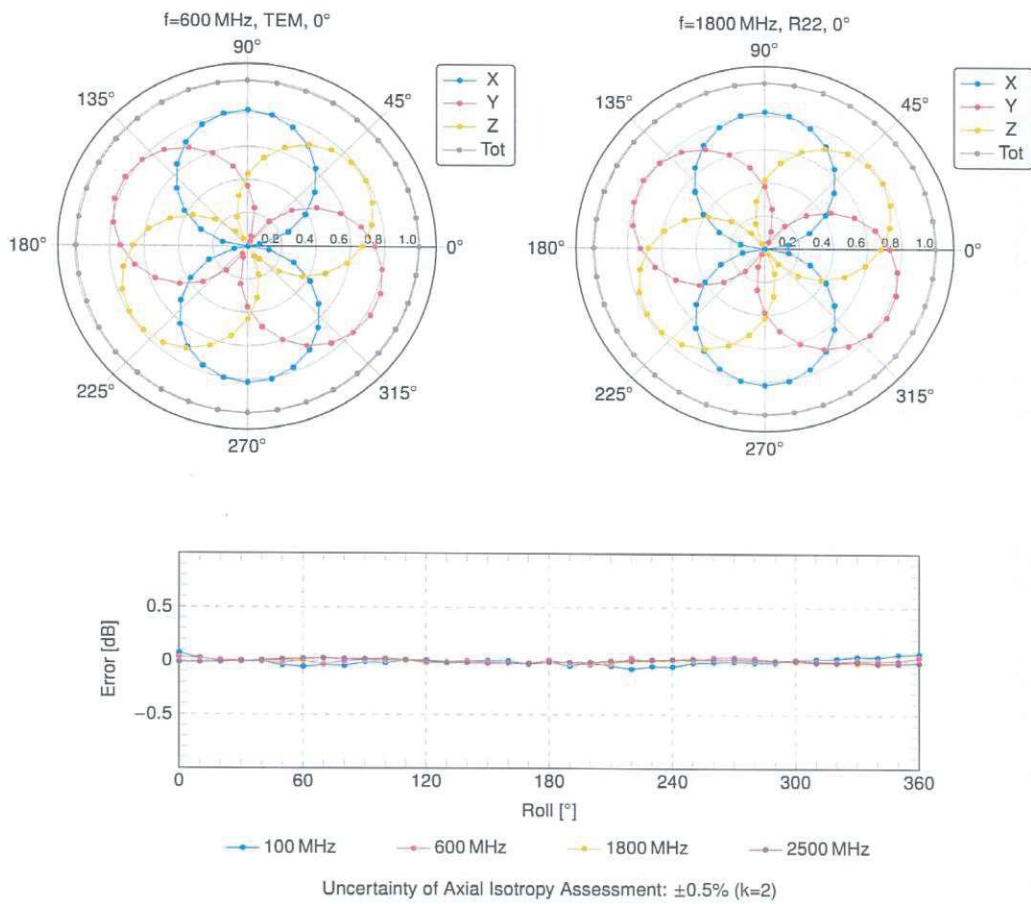



EX3DV4 - SN:3759

December 15, 2022

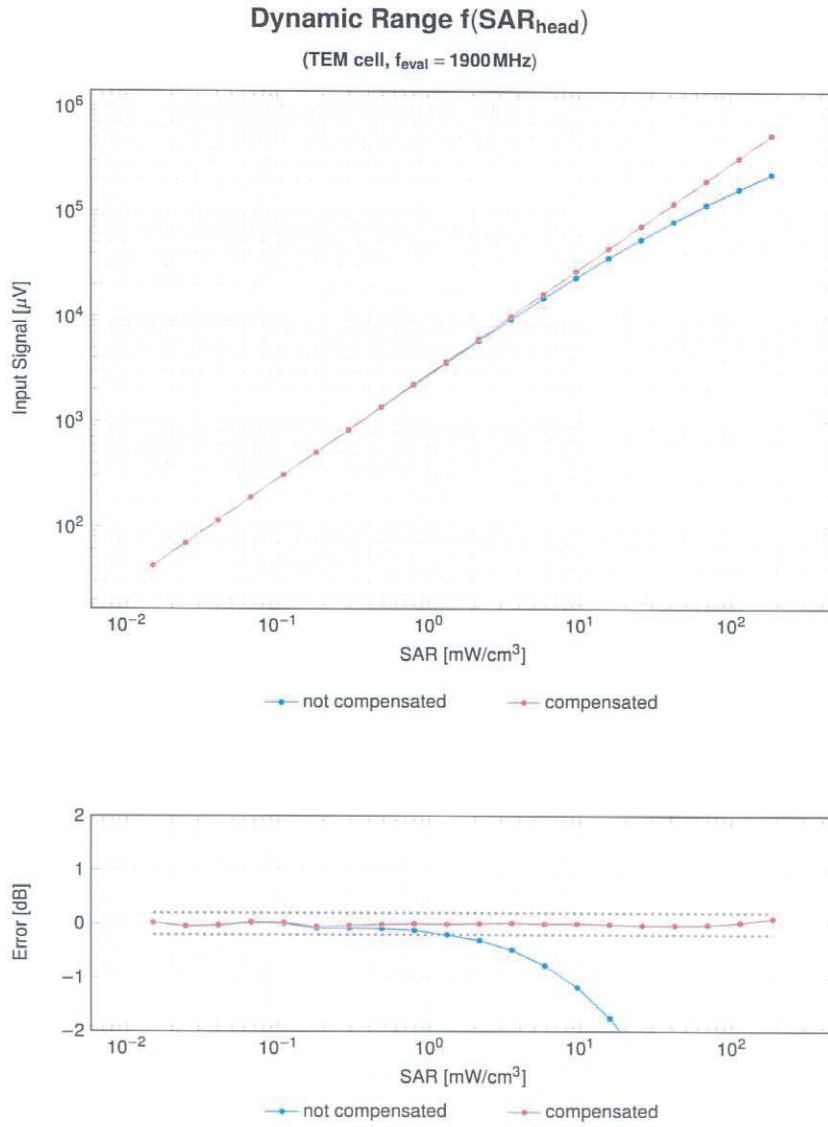

Uncertainty of Linearity Assessment: $\pm 0.6\%$ ($k=2$)



EX3DV4 - SN:3759

December 15, 2022

Conversion Factor Assessment

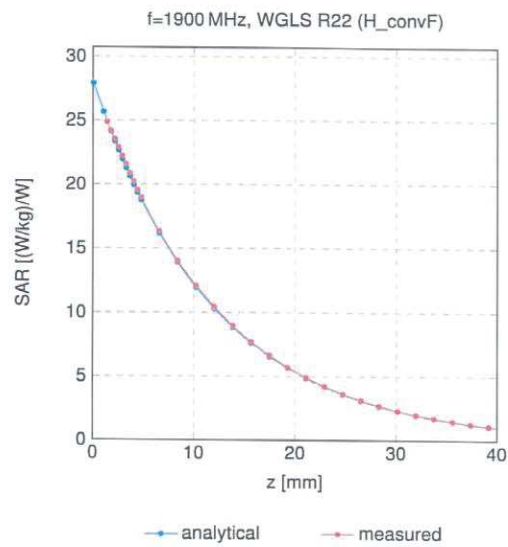

Deviation from Isotropy in Liquid

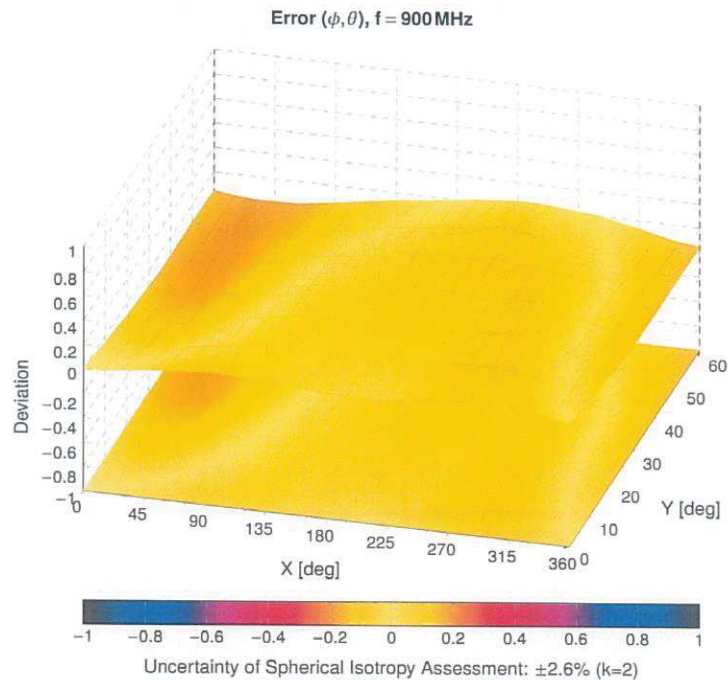



EX3DV4 - SN:3759

December 15, 2022

Appendix: Modulation Calibration Parameters

UID	Rev	Communication System Name	Group	PAR (dB)	Unc ^E k = 2
0		CW	CW	0.00	±4.7
10010	CAB	SAR Validation (Square, 100 ms, 10 ms)	Test	10.00	±9.6
10011	CAC	UMTS-FDD (WCDMA)	WCDMA	2.91	±9.6
10012	CAB	IEEE 802.11b WiFi 2.4 GHz (DSSS, 1 Mbps)	WLAN	1.87	±9.6
10013	CAB	IEEE 802.11g WiFi 2.4 GHz (DSSS-OFDM, 6 Mbps)	WLAN	9.46	±9.6
10021	DAC	GSM-FDD (TDMA, GMSK)	GSM	9.39	±9.6
10023	DAC	GPRS-FDD (TDMA, GMSK, TN 0)	GSM	9.57	±9.6
10024	DAC	GPRS-FDD (TDMA, GMSK, TN 0-1)	GSM	6.56	±9.6
10025	DAC	EDGE-FDD (TDMA, 8PSK, TN 0)	GSM	12.62	±9.6
10026	DAC	EDGE-FDD (TDMA, 8PSK, TN 0-1)	GSM	9.55	±9.6
10027	DAC	GPRS-FDD (TDMA, GMSK, TN 0-1-2)	GSM	4.80	±9.6
10028	DAC	GPRS-FDD (TDMA, GMSK, TN 0-1-2-3)	GSM	3.55	±9.6
10029	DAC	EDGE-FDD (TDMA, 8PSK, TN 0-1-2)	GSM	7.78	±9.6
10030	CAA	IEEE 802.15.1 Bluetooth (GFSK, DH1)	Bluetooth	5.30	±9.6
10031	CAA	IEEE 802.15.1 Bluetooth (GFSK, DH3)	Bluetooth	1.87	±9.6
10032	CAA	IEEE 802.15.1 Bluetooth (GFSK, DH5)	Bluetooth	1.16	±9.6
10033	CAA	IEEE 802.15.1 Bluetooth (PI/4-DQPSK, DH1)	Bluetooth	7.74	±9.6
10034	CAA	IEEE 802.15.1 Bluetooth (PI/4-DQPSK, DH3)	Bluetooth	4.53	±9.6
10035	CAA	IEEE 802.15.1 Bluetooth (PI/4-DQPSK, DH5)	Bluetooth	3.83	±9.6
10036	CAA	IEEE 802.15.1 Bluetooth (8-DPSK, DH1)	Bluetooth	8.01	±9.6
10037	CAA	IEEE 802.15.1 Bluetooth (8-DPSK, DH3)	Bluetooth	4.77	±9.6
10038	CAA	IEEE 802.15.1 Bluetooth (8-DPSK, DH5)	Bluetooth	4.10	±9.6
10039	CAB	CDMA2000 (1xRTT, RC1)	CDMA2000	4.57	±9.6
10042	CAB	IS-54 / IS-136 FDD (TDMA/FDM, PI/4-DQPSK, Halfrate)	AMPS	7.78	±9.6
10044	CAA	IS-91/EIA/TIA-553 FDD (FDMA, FM)	AMPS	0.00	±9.6
10048	CAA	DECT (TDD, TDMA/FDM, GFSK, Full Slot, 24)	DECT	13.80	±9.6
10049	CAA	DECT (TDD, TDMA/FDM, GFSK, Double Slot, 12)	DECT	10.79	±9.6
10056	CAA	UMTS-TDD (TD-SCDMA, 1.28 Mcps)	TD-SCDMA	11.01	±9.6
10058	DAC	EDGE-FDD (TDMA, 8PSK, TN 0-1-2-3)	GSM	6.52	±9.6
10059	CAB	IEEE 802.11b WiFi 2.4 GHz (DSSS, 2 Mbps)	WLAN	2.12	±9.6
10060	CAB	IEEE 802.11b WiFi 2.4 GHz (DSSS, 5.5 Mbps)	WLAN	2.83	±9.6
10061	CAB	IEEE 802.11b WiFi 2.4 GHz (DSSS, 11 Mbps)	WLAN	3.60	±9.6
10062	CAD	IEEE 802.11a/h WiFi 5 GHz (OFDM, 6 Mbps)	WLAN	8.68	±9.6
10063	CAD	IEEE 802.11a/h WiFi 5 GHz (OFDM, 9 Mbps)	WLAN	8.63	±9.6
10064	CAD	IEEE 802.11a/h WiFi 5 GHz (OFDM, 12 Mbps)	WLAN	9.09	±9.6
10065	CAD	IEEE 802.11a/h WiFi 5 GHz (OFDM, 18 Mbps)	WLAN	9.00	±9.6
10066	CAD	IEEE 802.11a/h WiFi 5 GHz (OFDM, 24 Mbps)	WLAN	9.38	±9.6
10067	CAD	IEEE 802.11a/h WiFi 5 GHz (OFDM, 36 Mbps)	WLAN	10.12	±9.6
10068	CAD	IEEE 802.11a/h WiFi 5 GHz (OFDM, 48 Mbps)	WLAN	10.24	±9.6
10069	CAD	IEEE 802.11a/h WiFi 5 GHz (OFDM, 54 Mbps)	WLAN	10.56	±9.6
10071	CAB	IEEE 802.11g WiFi 2.4 GHz (DSSS/OFDM, 9 Mbps)	WLAN	9.83	±9.6
10072	CAB	IEEE 802.11g WiFi 2.4 GHz (DSSS/OFDM, 12 Mbps)	WLAN	9.62	±9.6
10073	CAB	IEEE 802.11g WiFi 2.4 GHz (DSSS/OFDM, 18 Mbps)	WLAN	9.94	±9.6
10074	CAB	IEEE 802.11g WiFi 2.4 GHz (DSSS/OFDM, 24 Mbps)	WLAN	10.30	±9.6
10075	CAB	IEEE 802.11g WiFi 2.4 GHz (DSSS/OFDM, 36 Mbps)	WLAN	10.77	±9.6
10076	CAB	IEEE 802.11g WiFi 2.4 GHz (DSSS/OFDM, 48 Mbps)	WLAN	10.94	±9.6
10077	CAB	IEEE 802.11g WiFi 2.4 GHz (DSSS/OFDM, 54 Mbps)	WLAN	11.00	±9.6
10081	CAB	CDMA2000 (1xRTT, RC3)	CDMA2000	3.97	±9.6
10082	CAB	IS-54 / IS-136 FDD (TDMA/FDM, PI/4-DQPSK, Fullrate)	AMPS	4.77	±9.6
10090	DAC	GPRS-FDD (TDMA, GMSK, TN 0-4)	GSM	6.56	±9.6
10097	CAC	UMTS-FDD (HSDPA)	WCDMA	3.98	±9.6
10098	CAC	UMTS-FDD (HSUPA, Subtest 2)	WCDMA	3.98	±9.6
10099	DAC	EDGE-FDD (TDMA, 8PSK, TN 0-4)	GSM	9.55	±9.6
10100	CAF	LTE-FDD (SC-FDMA, 100% RB, 20 MHz, QPSK)	LTE-FDD	5.67	±9.6
10101	CAF	LTE-FDD (SC-FDMA, 100% RB, 20 MHz, 16-QAM)	LTE-FDD	6.42	±9.6
10102	CAF	LTE-FDD (SC-FDMA, 100% RB, 20 MHz, 64-QAM)	LTE-FDD	6.60	±9.6
10103	CAH	LTE-TDD (SC-FDMA, 100% RB, 20 MHz, QPSK)	LTE-TDD	9.29	±9.6
10104	CAH	LTE-TDD (SC-FDMA, 100% RB, 20 MHz, 16-QAM)	LTE-TDD	9.97	±9.6
10105	CAH	LTE-TDD (SC-FDMA, 100% RB, 20 MHz, 64-QAM)	LTE-TDD	10.01	±9.6
10108	CAH	LTE-FDD (SC-FDMA, 100% RB, 10 MHz, QPSK)	LTE-FDD	5.80	±9.6
10109	CAH	LTE-FDD (SC-FDMA, 100% RB, 10 MHz, 16-QAM)	LTE-FDD	6.43	±9.6
10110	CAH	LTE-FDD (SC-FDMA, 100% RB, 5 MHz, QPSK)	LTE-FDD	5.75	±9.6
10111	CAH	LTE-FDD (SC-FDMA, 100% RB, 5 MHz, 16-QAM)	LTE-FDD	6.44	±9.6



EX3DV4 - SN:3759

December 15, 2022

UID	Rev	Communication System Name	Group	PAR (dB)	Unc ^E k = 2
10112	CAH	LTE-FDD (SC-FDMA, 100% RB, 10 MHz, 64-QAM)	LTE-FDD	6.59	±9.6
10113	CAH	LTE-FDD (SC-FDMA, 100% RB, 5 MHz, 64-QAM)	LTE-FDD	6.62	±9.6
10114	CAD	IEEE 802.11n (HT Greenfield, 13.5 Mbps, BPSK)	WLAN	8.10	±9.6
10115	CAD	IEEE 802.11n (HT Greenfield, 81 Mbps, 16-QAM)	WLAN	8.46	±9.6
10116	CAD	IEEE 802.11n (HT Greenfield, 135 Mbps, 64-QAM)	WLAN	8.15	±9.6
10117	CAD	IEEE 802.11n (HT Mixed, 13.5 Mbps, BPSK)	WLAN	8.07	±9.6
10118	CAD	IEEE 802.11n (HT Mixed, 81 Mbps, 16-QAM)	WLAN	8.59	±9.6
10119	CAD	IEEE 802.11n (HT Mixed, 135 Mbps, 64-QAM)	WLAN	8.13	±9.6
10140	CAF	LTE-FDD (SC-FDMA, 100% RB, 15 MHz, 16-QAM)	LTE-FDD	6.49	±9.6
10141	CAF	LTE-FDD (SC-FDMA, 100% RB, 15 MHz, 64-QAM)	LTE-FDD	6.53	±9.6
10142	CAF	LTE-FDD (SC-FDMA, 100% RB, 3 MHz, QPSK)	LTE-FDD	5.73	±9.6
10143	CAF	LTE-FDD (SC-FDMA, 100% RB, 3 MHz, 16-QAM)	LTE-FDD	6.35	±9.6
10144	CAF	LTE-FDD (SC-FDMA, 100% RB, 3 MHz, 64-QAM)	LTE-FDD	6.65	±9.6
10145	CAG	LTE-FDD (SC-FDMA, 100% RB, 1.4 MHz, QPSK)	LTE-FDD	5.76	±9.6
10146	CAG	LTE-FDD (SC-FDMA, 100% RB, 1.4 MHz, 16-QAM)	LTE-FDD	6.41	±9.6
10147	CAG	LTE-FDD (SC-FDMA, 100% RB, 1.4 MHz, 64-QAM)	LTE-FDD	6.72	±9.6
10149	CAF	LTE-FDD (SC-FDMA, 50% RB, 20 MHz, 16-QAM)	LTE-FDD	6.42	±9.6
10150	CAF	LTE-FDD (SC-FDMA, 50% RB, 20 MHz, 64-QAM)	LTE-FDD	6.60	±9.6
10151	CAH	LTE-TDD (SC-FDMA, 50% RB, 20 MHz, QPSK)	LTE-TDD	9.28	±9.6
10152	CAH	LTE-TDD (SC-FDMA, 50% RB, 20 MHz, 16-QAM)	LTE-TDD	9.92	±9.6
10153	CAH	LTE-TDD (SC-FDMA, 50% RB, 20 MHz, 64-QAM)	LTE-TDD	10.05	±9.6
10154	CAH	LTE-FDD (SC-FDMA, 50% RB, 10 MHz, QPSK)	LTE-FDD	5.75	±9.6
10155	CAH	LTE-FDD (SC-FDMA, 50% RB, 10 MHz, 16-QAM)	LTE-FDD	6.43	±9.6
10156	CAH	LTE-FDD (SC-FDMA, 50% RB, 5 MHz, QPSK)	LTE-FDD	5.79	±9.6
10157	CAH	LTE-FDD (SC-FDMA, 50% RB, 5 MHz, 16-QAM)	LTE-FDD	6.49	±9.6
10158	CAH	LTE-FDD (SC-FDMA, 50% RB, 10 MHz, 64-QAM)	LTE-FDD	6.62	±9.6
10159	CAH	LTE-FDD (SC-FDMA, 50% RB, 5 MHz, 64-QAM)	LTE-FDD	6.56	±9.6
10160	CAF	LTE-FDD (SC-FDMA, 50% RB, 15 MHz, QPSK)	LTE-FDD	5.82	±9.6
10161	CAF	LTE-FDD (SC-FDMA, 50% RB, 15 MHz, 16-QAM)	LTE-FDD	6.43	±9.6
10162	CAF	LTE-FDD (SC-FDMA, 50% RB, 15 MHz, 64-QAM)	LTE-FDD	6.58	±9.6
10166	CAG	LTE-FDD (SC-FDMA, 50% RB, 1.4 MHz, QPSK)	LTE-FDD	5.46	±9.6
10167	CAG	LTE-FDD (SC-FDMA, 50% RB, 1.4 MHz, 16-QAM)	LTE-FDD	6.21	±9.6
10168	CAG	LTE-FDD (SC-FDMA, 50% RB, 1.4 MHz, 64-QAM)	LTE-FDD	6.79	±9.6
10169	CAF	LTE-FDD (SC-FDMA, 1 RB, 20 MHz, QPSK)	LTE-FDD	5.73	±9.6
10170	CAF	LTE-FDD (SC-FDMA, 1 RB, 20 MHz, 16-QAM)	LTE-FDD	6.52	±9.6
10171	AAF	LTE-FDD (SC-FDMA, 1 RB, 20 MHz, 64-QAM)	LTE-FDD	6.49	±9.6
10172	CAH	LTE-TDD (SC-FDMA, 1 RB, 20 MHz, QPSK)	LTE-TDD	9.21	±9.6
10173	CAH	LTE-TDD (SC-FDMA, 1 RB, 20 MHz, 16-QAM)	LTE-TDD	9.48	±9.6
10174	CAH	LTE-TDD (SC-FDMA, 1 RB, 20 MHz, 64-QAM)	LTE-TDD	10.25	±9.6
10175	CAH	LTE-FDD (SC-FDMA, 1 RB, 10 MHz, QPSK)	LTE-FDD	5.72	±9.6
10176	CAH	LTE-FDD (SC-FDMA, 1 RB, 10 MHz, 16-QAM)	LTE-FDD	6.52	±9.6
10177	CAJ	LTE-FDD (SC-FDMA, 1 RB, 5 MHz, QPSK)	LTE-FDD	5.73	±9.6
10178	CAH	LTE-FDD (SC-FDMA, 1 RB, 5 MHz, 16-QAM)	LTE-FDD	6.52	±9.6
10179	CAH	LTE-FDD (SC-FDMA, 1 RB, 10 MHz, 64-QAM)	LTE-FDD	6.50	±9.6
10180	CAH	LTE-FDD (SC-FDMA, 1 RB, 5 MHz, 64-QAM)	LTE-FDD	6.50	±9.6
10181	CAF	LTE-FDD (SC-FDMA, 1 RB, 15 MHz, QPSK)	LTE-FDD	5.72	±9.6
10182	CAF	LTE-FDD (SC-FDMA, 1 RB, 15 MHz, 16-QAM)	LTE-FDD	6.52	±9.6
10183	AAE	LTE-FDD (SC-FDMA, 1 RB, 15 MHz, 64-QAM)	LTE-FDD	6.50	±9.6
10184	CAF	LTE-FDD (SC-FDMA, 1 RB, 3 MHz, QPSK)	LTE-FDD	5.73	±9.6
10185	CAF	LTE-FDD (SC-FDMA, 1 RB, 3 MHz, 16-QAM)	LTE-FDD	6.51	±9.6
10186	AAF	LTE-FDD (SC-FDMA, 1 RB, 3 MHz, 64-QAM)	LTE-FDD	6.50	±9.6
10187	CAG	LTE-FDD (SC-FDMA, 1 RB, 1.4 MHz, QPSK)	LTE-FDD	5.73	±9.6
10188	CAG	LTE-FDD (SC-FDMA, 1 RB, 1.4 MHz, 16-QAM)	LTE-FDD	6.52	±9.6
10189	AAG	LTE-FDD (SC-FDMA, 1 RB, 1.4 MHz, 64-QAM)	LTE-FDD	6.50	±9.6
10193	CAD	IEEE 802.11n (HT Greenfield, 6.5 Mbps, BPSK)	WLAN	8.09	±9.6
10194	CAD	IEEE 802.11n (HT Greenfield, 39 Mbps, 16-QAM)	WLAN	8.12	±9.6
10195	CAD	IEEE 802.11n (HT Greenfield, 65 Mbps, 64-QAM)	WLAN	8.21	±9.6
10196	CAD	IEEE 802.11n (HT Mixed, 6.5 Mbps, BPSK)	WLAN	8.10	±9.6
10197	CAD	IEEE 802.11n (HT Mixed, 39 Mbps, 16-QAM)	WLAN	8.13	±9.6
10198	CAD	IEEE 802.11n (HT Mixed, 65 Mbps, 64-QAM)	WLAN	8.27	±9.6
10219	CAD	IEEE 802.11n (HT Mixed, 7.2 Mbps, BPSK)	WLAN	8.03	±9.6
10220	CAD	IEEE 802.11n (HT Mixed, 43.3 Mbps, 16-QAM)	WLAN	8.13	±9.6
10221	CAD	IEEE 802.11n (HT Mixed, 72.2 Mbps, 64-QAM)	WLAN	8.27	±9.6
10222	CAD	IEEE 802.11n (HT Mixed, 15 Mbps, BPSK)	WLAN	8.06	±9.6
10223	CAD	IEEE 802.11n (HT Mixed, 90 Mbps, 16-QAM)	WLAN	8.48	±9.6
10224	CAD	IEEE 802.11n (HT Mixed, 150 Mbps, 64-QAM)	WLAN	8.08	±9.6



EX3DV4 - SN:3759

December 15, 2022

UID	Rev	Communication System Name	Group	PAR (dB)	Unc ^F k = 2
10225	CAC	UMTS-FDD (HSPA+)	WCDMA	5.97	±9.6
10226	CAC	LTE-TDD (SC-FDMA, 1 RB, 1.4 MHz, 16-QAM)	LTE-TDD	9.49	±9.6
10227	CAC	LTE-TDD (SC-FDMA, 1 RB, 1.4 MHz, 64-QAM)	LTE-TDD	10.26	±9.6
10228	CAC	LTE-TDD (SC-FDMA, 1 RB, 1.4 MHz, QPSK)	LTE-TDD	9.22	±9.6
10229	CAE	LTE-TDD (SC-FDMA, 1 RB, 3 MHz, 16-QAM)	LTE-TDD	9.48	±9.6
10230	CAE	LTE-TDD (SC-FDMA, 1 RB, 3 MHz, 64-QAM)	LTE-TDD	10.25	±9.6
10231	CAE	LTE-TDD (SC-FDMA, 1 RB, 3 MHz, QPSK)	LTE-TDD	9.19	±9.6
10232	CAH	LTE-TDD (SC-FDMA, 1 RB, 5 MHz, 16-QAM)	LTE-TDD	9.48	±9.6
10233	CAH	LTE-TDD (SC-FDMA, 1 RB, 5 MHz, 64-QAM)	LTE-TDD	10.25	±9.6
10234	CAH	LTE-TDD (SC-FDMA, 1 RB, 5 MHz, QPSK)	LTE-TDD	9.21	±9.6
10235	CAH	LTE-TDD (SC-FDMA, 1 RB, 10 MHz, 16-QAM)	LTE-TDD	9.48	±9.6
10236	CAH	LTE-TDD (SC-FDMA, 1 RB, 10 MHz, 64-QAM)	LTE-TDD	10.25	±9.6
10237	CAH	LTE-TDD (SC-FDMA, 1 RB, 10 MHz, QPSK)	LTE-TDD	9.21	±9.6
10238	CAG	LTE-TDD (SC-FDMA, 1 RB, 15 MHz, 16-QAM)	LTE-TDD	9.48	±9.6
10239	CAG	LTE-TDD (SC-FDMA, 1 RB, 15 MHz, 64-QAM)	LTE-TDD	10.25	±9.6
10240	CAG	LTE-TDD (SC-FDMA, 1 RB, 15 MHz, QPSK)	LTE-TDD	9.21	±9.6
10241	CAC	LTE-TDD (SC-FDMA, 50% RB, 1.4 MHz, 16-QAM)	LTE-TDD	9.82	±9.6
10242	CAC	LTE-TDD (SC-FDMA, 50% RB, 1.4 MHz, 64-QAM)	LTE-TDD	9.86	±9.6
10243	CAC	LTE-TDD (SC-FDMA, 50% RB, 1.4 MHz, QPSK)	LTE-TDD	9.46	±9.6
10244	CAE	LTE-TDD (SC-FDMA, 50% RB, 3 MHz, 16-QAM)	LTE-TDD	10.06	±9.6
10245	CAE	LTE-TDD (SC-FDMA, 50% RB, 3 MHz, 64-QAM)	LTE-TDD	10.06	±9.6
10246	CAE	LTE-TDD (SC-FDMA, 50% RB, 3 MHz, QPSK)	LTE-TDD	9.30	±9.6
10247	CAH	LTE-TDD (SC-FDMA, 50% RB, 5 MHz, 16-QAM)	LTE-TDD	9.91	±9.6
10248	CAH	LTE-TDD (SC-FDMA, 50% RB, 5 MHz, 64-QAM)	LTE-TDD	10.09	±9.6
10249	CAH	LTE-TDD (SC-FDMA, 50% RB, 5 MHz, QPSK)	LTE-TDD	9.29	±9.6
10250	CAH	LTE-TDD (SC-FDMA, 50% RB, 10 MHz, 16-QAM)	LTE-TDD	9.81	±9.6
10251	CAH	LTE-TDD (SC-FDMA, 50% RB, 10 MHz, 64-QAM)	LTE-TDD	10.17	±9.6
10252	CAH	LTE-TDD (SC-FDMA, 50% RB, 10 MHz, QPSK)	LTE-TDD	9.24	±9.6
10253	CAG	LTE-TDD (SC-FDMA, 50% RB, 15 MHz, 16-QAM)	LTE-TDD	9.90	±9.6
10254	CAG	LTE-TDD (SC-FDMA, 50% RB, 15 MHz, 64-QAM)	LTE-TDD	10.14	±9.6
10255	CAG	LTE-TDD (SC-FDMA, 50% RB, 15 MHz, QPSK)	LTE-TDD	9.20	±9.6
10256	CAC	LTE-TDD (SC-FDMA, 100% RB, 1.4 MHz, 16-QAM)	LTE-TDD	9.96	±9.6
10257	CAC	LTE-TDD (SC-FDMA, 100% RB, 1.4 MHz, 64-QAM)	LTE-TDD	10.08	±9.6
10258	CAC	LTE-TDD (SC-FDMA, 100% RB, 1.4 MHz, QPSK)	LTE-TDD	9.34	±9.6
10259	CAE	LTE-TDD (SC-FDMA, 100% RB, 3 MHz, 16-QAM)	LTE-TDD	9.98	±9.6
10260	CAE	LTE-TDD (SC-FDMA, 100% RB, 3 MHz, 64-QAM)	LTE-TDD	9.97	±9.6
10261	CAE	LTE-TDD (SC-FDMA, 100% RB, 3 MHz, QPSK)	LTE-TDD	9.24	±9.6
10262	CAH	LTE-TDD (SC-FDMA, 100% RB, 5 MHz, 16-QAM)	LTE-TDD	9.83	±9.6
10263	CAH	LTE-TDD (SC-FDMA, 100% RB, 5 MHz, 64-QAM)	LTE-TDD	10.16	±9.6
10264	CAH	LTE-TDD (SC-FDMA, 100% RB, 5 MHz, QPSK)	LTE-TDD	9.23	±9.6
10265	CAH	LTE-TDD (SC-FDMA, 100% RB, 10 MHz, 16-QAM)	LTE-TDD	9.92	±9.6
10266	CAH	LTE-TDD (SC-FDMA, 100% RB, 10 MHz, 64-QAM)	LTE-TDD	10.07	±9.6
10267	CAH	LTE-TDD (SC-FDMA, 100% RB, 10 MHz, QPSK)	LTE-TDD	9.30	±9.6
10268	CAG	LTE-TDD (SC-FDMA, 100% RB, 15 MHz, 16-QAM)	LTE-TDD	10.06	±9.6
10269	CAG	LTE-TDD (SC-FDMA, 100% RB, 15 MHz, 64-QAM)	LTE-TDD	10.13	±9.6
10270	CAG	LTE-TDD (SC-FDMA, 100% RB, 15 MHz, QPSK)	LTE-TDD	9.58	±9.6
10274	CAC	UMTS-FDD (HSUPA, Subtest 5, 3GPP Rel8.10)	WCDMA	4.87	±9.6
10275	CAC	UMTS-FDD (HSUPA, Subtest 5, 3GPP Rel8.4)	WCDMA	3.96	±9.6
10277	CAA	PHS (QPSK)	PHS	11.81	±9.6
10278	CAA	PHS (QPSK, BW 884 MHz, Rolloff 0.5)	PHS	11.81	±9.6
10279	CAA	PHS (QPSK, BW 884 MHz, Rolloff 0.38)	PHS	12.18	±9.6
10290	AAB	CDMA2000, RC1, SO55, Full Rate	CDMA2000	3.91	±9.6
10291	AAB	CDMA2000, RC3, SO55, Full Rate	CDMA2000	3.46	±9.6
10292	AAB	CDMA2000, RC3, SO32, Full Rate	CDMA2000	3.39	±9.6
10293	AAB	CDMA2000, RC3, SO3, Full Rate	CDMA2000	3.50	±9.6
10295	AAB	CDMA2000, RC1, SO3, 1/8th Rate 25 fr.	CDMA2000	12.49	±9.6
10297	AAE	LTE-FDD (SC-FDMA, 50% RB, 20 MHz, QPSK)	LTE-FDD	5.81	±9.6
10298	AAE	LTE-FDD (SC-FDMA, 50% RB, 3 MHz, QPSK)	LTE-FDD	5.72	±9.6
10299	AAE	LTE-FDD (SC-FDMA, 50% RB, 3 MHz, 16-QAM)	LTE-FDD	6.39	±9.6
10300	AAE	LTE-FDD (SC-FDMA, 50% RB, 3 MHz, 64-QAM)	LTE-FDD	6.60	±9.6
10301	AAA	IEEE 802.16e WiMAX (29:18, 5 ms, 10 MHz, QPSK, PUSC)	WiMAX	12.03	±9.6
10302	AAA	IEEE 802.16e WiMAX (29:18, 5 ms, 10 MHz, QPSK, PUSC, 3 CTRL symbols)	WiMAX	12.57	±9.6
10303	AAA	IEEE 802.16e WiMAX (31:15, 5 ms, 10 MHz, 64QAM, PUSC)	WiMAX	12.52	±9.6
10304	AAA	IEEE 802.16e WiMAX (29:18, 5 ms, 10 MHz, 64QAM, PUSC)	WiMAX	11.86	±9.6
10305	AAA	IEEE 802.16e WiMAX (31:15, 10 ms, 10 MHz, 64QAM, PUSC, 15 symbols)	WiMAX	15.24	±9.6
10306	AAA	IEEE 802.16e WiMAX (29:18, 10 ms, 10 MHz, 64QAM, PUSC, 18 symbols)	WiMAX	14.67	±9.6



EX3DV4 - SN:3759

December 15, 2022

UID	Rev	Communication System Name	Group	PAR (dB)	Unc ^F k = 2
10307	AAA	IEEE 802.16e WiMAX (29:18, 10 ms, 10 MHz, QPSK, PUSC, 18 symbols)	WiMAX	14.49	±9.6
10308	AAA	IEEE 802.16e WiMAX (29:18, 10 ms, 10 MHz, 16QAM, PUSC)	WiMAX	14.46	±9.6
10309	AAA	IEEE 802.16e WiMAX (29:18, 10 ms, 10 MHz, 16QAM, AMC 2x3, 18 symbols)	WiMAX	14.58	±9.6
10310	AAA	IEEE 802.16e WiMAX (29:18, 10 ms, 10 MHz, QPSK, AMC 2x3, 18 symbols)	WiMAX	14.57	±9.6
10311	AAE	LTE-FDD (SC-FDMA, 100% RB, 15 MHz, QPSK)	LTE-FDD	6.06	±9.6
10313	AAA	iDEN 1:3	iDEN	10.51	±9.6
10314	AAA	iDEN 1:6	iDEN	13.48	±9.6
10315	AAB	IEEE 802.11b WiFi 2.4 GHz (DSSS, 1 Mbps, 96pc duty cycle)	WLAN	1.71	±9.6
10316	AAB	IEEE 802.11g WiFi 2.4 GHz (ERP-OFDM, 6 Mbps, 96pc duty cycle)	WLAN	8.36	±9.6
10317	AAD	IEEE 802.11a WiFi 5 GHz (OFDM, 6 Mbps, 96pc duty cycle)	WLAN	8.36	±9.6
10352	AAA	Pulse Waveform (200Hz, 10%)	Generic	10.00	±9.6
10353	AAA	Pulse Waveform (200Hz, 20%)	Generic	6.99	±9.6
10354	AAA	Pulse Waveform (200Hz, 40%)	Generic	3.98	±9.6
10355	AAA	Pulse Waveform (200Hz, 60%)	Generic	2.22	±9.6
10356	AAA	Pulse Waveform (200Hz, 80%)	Generic	0.97	±9.6
10387	AAA	QPSK Waveform, 1 MHz	Generic	5.10	±9.6
10388	AAA	QPSK Waveform, 10 MHz	Generic	5.22	±9.6
10396	AAA	64-QAM Waveform, 100 kHz	Generic	6.27	±9.6
10399	AAA	64-QAM Waveform, 40 MHz	Generic	6.27	±9.6
10400	AAE	IEEE 802.11ac WiFi (20 MHz, 64-QAM, 99pc duty cycle)	WLAN	8.37	±9.6
10401	AAE	IEEE 802.11ac WiFi (40 MHz, 64-QAM, 99pc duty cycle)	WLAN	8.60	±9.6
10402	AAE	IEEE 802.11ac WiFi (80 MHz, 64-QAM, 99pc duty cycle)	WLAN	8.53	±9.6
10403	AAB	CDMA2000 (1xEV-DO, Rev. 0)	CDMA2000	3.76	±9.6
10404	AAB	CDMA2000 (1xEV-DO, Rev. A)	CDMA2000	3.77	±9.6
10406	AAB	CDMA2000, RC3, SO32, SCH0, Full Rate	CDMA2000	5.22	±9.6
10410	AAH	LTE-TDD (SC-FDMA, 1 RB, 10 MHz, QPSK, UL Subframe=2,3,4,7,8,9, Subframe Conf=4)	LTE-TDD	7.82	±9.6
10414	AAA	WLAN CCDF, 64-QAM, 40 MHz	Generic	8.54	±9.6
10415	AAA	IEEE 802.11b WiFi 2.4 GHz (DSSS, 1 Mbps, 99pc duty cycle)	WLAN	1.54	±9.6
10416	AAA	IEEE 802.11g WiFi 2.4 GHz (ERP-OFDM, 6 Mbps, 99pc duty cycle)	WLAN	8.23	±9.6
10417	AAC	IEEE 802.11a/h WiFi 5 GHz (OFDM, 6 Mbps, 99pc duty cycle)	WLAN	8.23	±9.6
10418	AAA	IEEE 802.11g WiFi 2.4 GHz (DSSS-OFDM, 6 Mbps, 99pc duty cycle, Long preamble)	WLAN	8.14	±9.6
10419	AAA	IEEE 802.11g WiFi 2.4 GHz (DSSS-OFDM, 6 Mbps, 99pc duty cycle, Short preamble)	WLAN	8.19	±9.6
10422	AAC	IEEE 802.11n (HT Greenfield, 7.2 Mbps, BPSK)	WLAN	8.32	±9.6
10423	AAC	IEEE 802.11n (HT Greenfield, 43.3 Mbps, 16-QAM)	WLAN	8.47	±9.6
10424	AAC	IEEE 802.11n (HT Greenfield, 72.2 Mbps, 64-QAM)	WLAN	8.40	±9.6
10425	AAC	IEEE 802.11n (HT Greenfield, 15 Mbps, BPSK)	WLAN	8.41	±9.6
10426	AAC	IEEE 802.11n (HT Greenfield, 90 Mbps, 16-QAM)	WLAN	8.45	±9.6
10427	AAC	IEEE 802.11n (HT Greenfield, 150 Mbps, 64-QAM)	WLAN	8.41	±9.6
10430	AAE	LTE-FDD (OFDMA, 5 MHz, E-TM 3.1)	LTE-FDD	8.28	±9.6
10431	AAE	LTE-FDD (OFDMA, 10 MHz, E-TM 3.1)	LTE-FDD	8.38	±9.6
10432	AAD	LTE-FDD (OFDMA, 15 MHz, E-TM 3.1)	LTE-FDD	8.34	±9.6
10433	AAD	LTE-FDD (OFDMA, 20 MHz, E-TM 3.1)	LTE-FDD	8.34	±9.6
10434	AAB	W-CDMA (BS Test Model 1, 64 DPCH)	WCDMA	8.60	±9.6
10435	AAG	LTE-TDD (SC-FDMA, 1 RB, 20 MHz, QPSK, UL Subframe=2,3,4,7,8,9)	LTE-TDD	7.82	±9.6
10447	AAE	LTE-FDD (OFDMA, 5 MHz, E-TM 3.1, Clipping 44%)	LTE-FDD	7.56	±9.6
10448	AAE	LTE-FDD (OFDMA, 10 MHz, E-TM 3.1, Clipping 44%)	LTE-FDD	7.53	±9.6
10449	AAD	LTE-FDD (OFDMA, 15 MHz, E-TM 3.1, Clipping 44%)	LTE-FDD	7.51	±9.6
10450	AAD	LTE-FDD (OFDMA, 20 MHz, E-TM 3.1, Clipping 44%)	LTE-FDD	7.48	±9.6
10451	AAB	W-CDMA (BS Test Model 1, 64 DPCH, Clipping 44%)	WCDMA	7.59	±9.6
10453	AAE	Validation (Square, 10 ms, 1 ms)	Test	10.00	±9.6
10456	AAC	IEEE 802.11ac WiFi (160 MHz, 64-QAM, 99pc duty cycle)	WLAN	8.63	±9.6
10457	AAB	UMTS-FDD (DC-HSDPA)	WCDMA	6.62	±9.6
10458	AAA	CDMA2000 (1xEV-DO, Rev. B, 2 carriers)	CDMA2000	6.55	±9.6
10459	AAA	CDMA2000 (1xEV-DO, Rev. B, 3 carriers)	CDMA2000	8.25	±9.6
10460	AAB	UMTS-FDD (WCDMA, AMR)	WCDMA	2.39	±9.6
10461	AAC	LTE-TDD (SC-FDMA, 1 RB, 1.4 MHz, QPSK, UL Subframe=2,3,4,7,8,9)	LTE-TDD	7.82	±9.6
10462	AAC	LTE-TDD (SC-FDMA, 1 RB, 1.4 MHz, 16-QAM, UL Subframe=2,3,4,7,8,9)	LTE-TDD	8.30	±9.6
10463	AAC	LTE-TDD (SC-FDMA, 1 RB, 1.4 MHz, 64-QAM, UL Subframe=2,3,4,7,8,9)	LTE-TDD	8.56	±9.6
10464	AAD	LTE-TDD (SC-FDMA, 1 RB, 3 MHz, QPSK, UL Subframe=2,3,4,7,8,9)	LTE-TDD	7.82	±9.6
10465	AAD	LTE-TDD (SC-FDMA, 1 RB, 3 MHz, 16-QAM, UL Subframe=2,3,4,7,8,9)	LTE-TDD	8.32	±9.6
10466	AAD	LTE-TDD (SC-FDMA, 1 RB, 3 MHz, 64-QAM, UL Subframe=2,3,4,7,8,9)	LTE-TDD	8.57	±9.6
10467	AAG	LTE-TDD (SC-FDMA, 1 RB, 5 MHz, QPSK, UL Subframe=2,3,4,7,8,9)	LTE-TDD	7.82	±9.6
10468	AAG	LTE-TDD (SC-FDMA, 1 RB, 5 MHz, 16-QAM, UL Subframe=2,3,4,7,8,9)	LTE-TDD	8.32	±9.6
10469	AAG	LTE-TDD (SC-FDMA, 1 RB, 5 MHz, 64-QAM, UL Subframe=2,3,4,7,8,9)	LTE-TDD	8.56	±9.6
10470	AAG	LTE-TDD (SC-FDMA, 1 RB, 10 MHz, QPSK, UL Subframe=2,3,4,7,8,9)	LTE-TDD	7.82	±9.6
10471	AAG	LTE-TDD (SC-FDMA, 1 RB, 10 MHz, 16-QAM, UL Subframe=2,3,4,7,8,9)	LTE-TDD	8.32	±9.6



EX3DV4 - SN:3759

December 15, 2022

UID	Rev	Communication System Name	Group	PAR (dB)	Unc ^E k = 2
10472	AAG	LTE-TDD (SC-FDMA, 1 RB, 10 MHz, 64-QAM, UL Subframe=2,3,4,7,8,9)	LTE-TDD	8.57	±9.6
10473	AAF	LTE-TDD (SC-FDMA, 1 RB, 15 MHz, QPSK, UL Subframe=2,3,4,7,8,9)	LTE-TDD	7.82	±9.6
10474	AAF	LTE-TDD (SC-FDMA, 1 RB, 15 MHz, 16-QAM, UL Subframe=2,3,4,7,8,9)	LTE-TDD	8.32	±9.6
10475	AAF	LTE-TDD (SC-FDMA, 1 RB, 15 MHz, 64-QAM, UL Subframe=2,3,4,7,8,9)	LTE-TDD	8.57	±9.6
10477	AAG	LTE-TDD (SC-FDMA, 1 RB, 20 MHz, 16-QAM, UL Subframe=2,3,4,7,8,9)	LTE-TDD	8.32	±9.6
10478	AAG	LTE-TDD (SC-FDMA, 1 RB, 20 MHz, 64-QAM, UL Subframe=2,3,4,7,8,9)	LTE-TDD	8.57	±9.6
10479	AAC	LTE-TDD (SC-FDMA, 50% RB, 1.4 MHz, QPSK, UL Subframe=2,3,4,7,8,9)	LTE-TDD	7.74	±9.6
10480	AAC	LTE-TDD (SC-FDMA, 50% RB, 1.4 MHz, 16-QAM, UL Subframe=2,3,4,7,8,9)	LTE-TDD	8.18	±9.6
10481	AAC	LTE-TDD (SC-FDMA, 50% RB, 1.4 MHz, 64-QAM, UL Subframe=2,3,4,7,8,9)	LTE-TDD	8.45	±9.6
10482	AAD	LTE-TDD (SC-FDMA, 50% RB, 3 MHz, QPSK, UL Subframe=2,3,4,7,8,9)	LTE-TDD	7.71	±9.6
10483	AAD	LTE-TDD (SC-FDMA, 50% RB, 3 MHz, 16-QAM, UL Subframe=2,3,4,7,8,9)	LTE-TDD	8.39	±9.6
10484	AAD	LTE-TDD (SC-FDMA, 50% RB, 3 MHz, 64-QAM, UL Subframe=2,3,4,7,8,9)	LTE-TDD	8.47	±9.6
10485	AAG	LTE-TDD (SC-FDMA, 50% RB, 5 MHz, QPSK, UL Subframe=2,3,4,7,8,9)	LTE-TDD	7.59	±9.6
10486	AAG	LTE-TDD (SC-FDMA, 50% RB, 5 MHz, 16-QAM, UL Subframe=2,3,4,7,8,9)	LTE-TDD	8.38	±9.6
10487	AAG	LTE-TDD (SC-FDMA, 50% RB, 5 MHz, 64-QAM, UL Subframe=2,3,4,7,8,9)	LTE-TDD	8.60	±9.6
10488	AAG	LTE-TDD (SC-FDMA, 50% RB, 10 MHz, QPSK, UL Subframe=2,3,4,7,8,9)	LTE-TDD	7.70	±9.6
10489	AAG	LTE-TDD (SC-FDMA, 50% RB, 10 MHz, 16-QAM, UL Subframe=2,3,4,7,8,9)	LTE-TDD	8.31	±9.6
10490	AAG	LTE-TDD (SC-FDMA, 50% RB, 10 MHz, 64-QAM, UL Subframe=2,3,4,7,8,9)	LTE-TDD	8.54	±9.6
10491	AAF	LTE-TDD (SC-FDMA, 50% RB, 15 MHz, QPSK, UL Subframe=2,3,4,7,8,9)	LTE-TDD	7.74	±9.6
10492	AAF	LTE-TDD (SC-FDMA, 50% RB, 15 MHz, 16-QAM, UL Subframe=2,3,4,7,8,9)	LTE-TDD	8.41	±9.6
10493	AAF	LTE-TDD (SC-FDMA, 50% RB, 15 MHz, 64-QAM, UL Subframe=2,3,4,7,8,9)	LTE-TDD	8.55	±9.6
10494	AAG	LTE-TDD (SC-FDMA, 50% RB, 20 MHz, QPSK, UL Subframe=2,3,4,7,8,9)	LTE-TDD	7.74	±9.6
10495	AAG	LTE-TDD (SC-FDMA, 50% RB, 20 MHz, 16-QAM, UL Subframe=2,3,4,7,8,9)	LTE-TDD	8.37	±9.6
10496	AAG	LTE-TDD (SC-FDMA, 50% RB, 20 MHz, 64-QAM, UL Subframe=2,3,4,7,8,9)	LTE-TDD	8.54	±9.6
10497	AAC	LTE-TDD (SC-FDMA, 100% RB, 1.4 MHz, QPSK, UL Subframe=2,3,4,7,8,9)	LTE-TDD	7.67	±9.6
10498	AAC	LTE-TDD (SC-FDMA, 100% RB, 1.4 MHz, 16-QAM, UL Subframe=2,3,4,7,8,9)	LTE-TDD	8.40	±9.6
10499	AAC	LTE-TDD (SC-FDMA, 100% RB, 1.4 MHz, 64-QAM, UL Subframe=2,3,4,7,8,9)	LTE-TDD	8.68	±9.6
10500	AAD	LTE-TDD (SC-FDMA, 100% RB, 3 MHz, QPSK, UL Subframe=2,3,4,7,8,9)	LTE-TDD	7.67	±9.6
10501	AAD	LTE-TDD (SC-FDMA, 100% RB, 3 MHz, 16-QAM, UL Subframe=2,3,4,7,8,9)	LTE-TDD	8.44	±9.6
10502	AAD	LTE-TDD (SC-FDMA, 100% RB, 3 MHz, 64-QAM, UL Subframe=2,3,4,7,8,9)	LTE-TDD	8.52	±9.6
10503	AAG	LTE-TDD (SC-FDMA, 100% RB, 5 MHz, QPSK, UL Subframe=2,3,4,7,8,9)	LTE-TDD	7.72	±9.6
10504	AAG	LTE-TDD (SC-FDMA, 100% RB, 5 MHz, 16-QAM, UL Subframe=2,3,4,7,8,9)	LTE-TDD	8.31	±9.6
10505	AAG	LTE-TDD (SC-FDMA, 100% RB, 5 MHz, 64-QAM, UL Subframe=2,3,4,7,8,9)	LTE-TDD	8.54	±9.6
10506	AAG	LTE-TDD (SC-FDMA, 100% RB, 10 MHz, QPSK, UL Subframe=2,3,4,7,8,9)	LTE-TDD	7.74	±9.6
10507	AAG	LTE-TDD (SC-FDMA, 100% RB, 10 MHz, 16-QAM, UL Subframe=2,3,4,7,8,9)	LTE-TDD	8.36	±9.6
10508	AAG	LTE-TDD (SC-FDMA, 100% RB, 10 MHz, 64-QAM, UL Subframe=2,3,4,7,8,9)	LTE-TDD	8.55	±9.6
10509	AAF	LTE-TDD (SC-FDMA, 100% RB, 15 MHz, QPSK, UL Subframe=2,3,4,7,8,9)	LTE-TDD	7.99	±9.6
10510	AAF	LTE-TDD (SC-FDMA, 100% RB, 15 MHz, 16-QAM, UL Subframe=2,3,4,7,8,9)	LTE-TDD	8.49	±9.6
10511	AAF	LTE-TDD (SC-FDMA, 100% RB, 15 MHz, 64-QAM, UL Subframe=2,3,4,7,8,9)	LTE-TDD	8.51	±9.6
10512	AAG	LTE-TDD (SC-FDMA, 100% RB, 20 MHz, QPSK, UL Subframe=2,3,4,7,8,9)	LTE-TDD	7.74	±9.6
10513	AAG	LTE-TDD (SC-FDMA, 100% RB, 20 MHz, 16-QAM, UL Subframe=2,3,4,7,8,9)	LTE-TDD	8.42	±9.6
10514	AAG	LTE-TDD (SC-FDMA, 100% RB, 20 MHz, 64-QAM, UL Subframe=2,3,4,7,8,9)	LTE-TDD	8.45	±9.6
10515	AAA	IEEE 802.11b WiFi 2.4 GHz (DSSS, 2 Mbps, 99pc duty cycle)	WLAN	1.58	±9.6
10516	AAA	IEEE 802.11b WiFi 2.4 GHz (DSSS, 5.5 Mbps, 99pc duty cycle)	WLAN	1.57	±9.6
10517	AAA	IEEE 802.11b WiFi 2.4 GHz (DSSS, 11 Mbps, 99pc duty cycle)	WLAN	1.58	±9.6
10518	AAC	IEEE 802.11a/h WiFi 5 GHz (OFDM, 9 Mbps, 99pc duty cycle)	WLAN	8.23	±9.6
10519	AAC	IEEE 802.11a/h WiFi 5 GHz (OFDM, 12 Mbps, 99pc duty cycle)	WLAN	8.39	±9.6
10520	AAC	IEEE 802.11a/h WiFi 5 GHz (OFDM, 18 Mbps, 99pc duty cycle)	WLAN	8.12	±9.6
10521	AAC	IEEE 802.11a/h WiFi 5 GHz (OFDM, 24 Mbps, 99pc duty cycle)	WLAN	7.97	±9.6
10522	AAC	IEEE 802.11a/h WiFi 5 GHz (OFDM, 36 Mbps, 99pc duty cycle)	WLAN	8.45	±9.6
10523	AAC	IEEE 802.11a/h WiFi 5 GHz (OFDM, 48 Mbps, 99pc duty cycle)	WLAN	8.08	±9.6
10524	AAC	IEEE 802.11a/h WiFi 5 GHz (OFDM, 54 Mbps, 99pc duty cycle)	WLAN	8.27	±9.6
10525	AAC	IEEE 802.11ac WiFi (20 MHz, MCS0, 99pc duty cycle)	WLAN	8.36	±9.6
10526	AAC	IEEE 802.11ac WiFi (20 MHz, MCS1, 99pc duty cycle)	WLAN	8.42	±9.6
10527	AAC	IEEE 802.11ac WiFi (20 MHz, MCS2, 99pc duty cycle)	WLAN	8.21	±9.6
10528	AAC	IEEE 802.11ac WiFi (20 MHz, MCS3, 99pc duty cycle)	WLAN	8.36	±9.6
10529	AAC	IEEE 802.11ac WiFi (20 MHz, MCS4, 99pc duty cycle)	WLAN	8.36	±9.6
10531	AAC	IEEE 802.11ac WiFi (20 MHz, MCS6, 99pc duty cycle)	WLAN	8.43	±9.6
10532	AAC	IEEE 802.11ac WiFi (20 MHz, MCS7, 99pc duty cycle)	WLAN	8.29	±9.6
10533	AAC	IEEE 802.11ac WiFi (20 MHz, MCS8, 99pc duty cycle)	WLAN	8.38	±9.6
10534	AAC	IEEE 802.11ac WiFi (40 MHz, MCS0, 99pc duty cycle)	WLAN	8.45	±9.6
10535	AAC	IEEE 802.11ac WiFi (40 MHz, MCS1, 99pc duty cycle)	WLAN	8.45	±9.6
10536	AAC	IEEE 802.11ac WiFi (40 MHz, MCS2, 99pc duty cycle)	WLAN	8.32	±9.6
10537	AAC	IEEE 802.11ac WiFi (40 MHz, MCS3, 99pc duty cycle)	WLAN	8.44	±9.6
10538	AAC	IEEE 802.11ac WiFi (40 MHz, MCS4, 99pc duty cycle)	WLAN	8.54	±9.6
10540	AAC	IEEE 802.11ac WiFi (40 MHz, MCS6, 99pc duty cycle)	WLAN	8.39	±9.6



EX3DV4 - SN:3759

December 15, 2022

UID	Rev	Communication System Name	Group	PAR (dB)	Unc ^F k = 2
10541	AAC	IEEE 802.11ac WiFi (40 MHz, MCS7, 99pc duty cycle)	WLAN	8.46	±9.6
10542	AAC	IEEE 802.11ac WiFi (40 MHz, MCS8, 99pc duty cycle)	WLAN	8.65	±9.6
10543	AAC	IEEE 802.11ac WiFi (40 MHz, MCS9, 99pc duty cycle)	WLAN	8.65	±9.6
10544	AAC	IEEE 802.11ac WiFi (80 MHz, MCS0, 99pc duty cycle)	WLAN	8.47	±9.6
10545	AAC	IEEE 802.11ac WiFi (80 MHz, MCS1, 99pc duty cycle)	WLAN	8.55	±9.6
10546	AAC	IEEE 802.11ac WiFi (80 MHz, MCS2, 99pc duty cycle)	WLAN	8.35	±9.6
10547	AAC	IEEE 802.11ac WiFi (80 MHz, MCS3, 99pc duty cycle)	WLAN	8.49	±9.6
10548	AAC	IEEE 802.11ac WiFi (80 MHz, MCS4, 99pc duty cycle)	WLAN	8.37	±9.6
10550	AAC	IEEE 802.11ac WiFi (80 MHz, MCS6, 99pc duty cycle)	WLAN	8.38	±9.6
10551	AAC	IEEE 802.11ac WiFi (80 MHz, MCS7, 99pc duty cycle)	WLAN	8.50	±9.6
10552	AAC	IEEE 802.11ac WiFi (80 MHz, MCS8, 99pc duty cycle)	WLAN	8.42	±9.6
10553	AAC	IEEE 802.11ac WiFi (80 MHz, MCS9, 99pc duty cycle)	WLAN	8.45	±9.6
10554	AAD	IEEE 802.11ac WiFi (160 MHz, MCS0, 99pc duty cycle)	WLAN	8.48	±9.6
10555	AAD	IEEE 802.11ac WiFi (160 MHz, MCS1, 99pc duty cycle)	WLAN	8.47	±9.6
10556	AAD	IEEE 802.11ac WiFi (160 MHz, MCS2, 99pc duty cycle)	WLAN	8.50	±9.6
10557	AAD	IEEE 802.11ac WiFi (160 MHz, MCS3, 99pc duty cycle)	WLAN	8.52	±9.6
10558	AAD	IEEE 802.11ac WiFi (160 MHz, MCS4, 99pc duty cycle)	WLAN	8.61	±9.6
10560	AAD	IEEE 802.11ac WiFi (160 MHz, MCS6, 99pc duty cycle)	WLAN	8.73	±9.6
10561	AAD	IEEE 802.11ac WiFi (160 MHz, MCS7, 99pc duty cycle)	WLAN	8.56	±9.6
10562	AAD	IEEE 802.11ac WiFi (160 MHz, MCS8, 99pc duty cycle)	WLAN	8.69	±9.6
10563	AAD	IEEE 802.11ac WiFi (160 MHz, MCS9, 99pc duty cycle)	WLAN	8.77	±9.6
10564	AAA	IEEE 802.11g WiFi 2.4 GHz (DSSS-OFDM, 9 Mbps, 99pc duty cycle)	WLAN	8.25	±9.6
10565	AAA	IEEE 802.11g WiFi 2.4 GHz (DSSS-OFDM, 12 Mbps, 99pc duty cycle)	WLAN	8.45	±9.6
10566	AAA	IEEE 802.11g WiFi 2.4 GHz (DSSS-OFDM, 18 Mbps, 99pc duty cycle)	WLAN	8.13	±9.6
10567	AAA	IEEE 802.11g WiFi 2.4 GHz (DSSS-OFDM, 24 Mbps, 99pc duty cycle)	WLAN	8.00	±9.6
10568	AAA	IEEE 802.11g WiFi 2.4 GHz (DSSS-OFDM, 36 Mbps, 99pc duty cycle)	WLAN	8.37	±9.6
10569	AAA	IEEE 802.11g WiFi 2.4 GHz (DSSS-OFDM, 48 Mbps, 99pc duty cycle)	WLAN	8.10	±9.6
10570	AAA	IEEE 802.11g WiFi 2.4 GHz (DSSS-OFDM, 54 Mbps, 99pc duty cycle)	WLAN	8.30	±9.6
10571	AAA	IEEE 802.11b WiFi 2.4 GHz (DSSS, 1 Mbps, 90pc duty cycle)	WLAN	1.99	±9.6
10572	AAA	IEEE 802.11b WiFi 2.4 GHz (DSSS, 2 Mbps, 90pc duty cycle)	WLAN	1.99	±9.6
10573	AAA	IEEE 802.11b WiFi 2.4 GHz (DSSS, 5.5 Mbps, 90pc duty cycle)	WLAN	1.98	±9.6
10574	AAA	IEEE 802.11b WiFi 2.4 GHz (DSSS, 11 Mbps, 90pc duty cycle)	WLAN	1.98	±9.6
10575	AAA	IEEE 802.11g WiFi 2.4 GHz (DSSS-OFDM, 6 Mbps, 90pc duty cycle)	WLAN	8.59	±9.6
10576	AAA	IEEE 802.11g WiFi 2.4 GHz (DSSS-OFDM, 9 Mbps, 90pc duty cycle)	WLAN	8.60	±9.6
10577	AAA	IEEE 802.11g WiFi 2.4 GHz (DSSS-OFDM, 12 Mbps, 90pc duty cycle)	WLAN	8.70	±9.6
10578	AAA	IEEE 802.11g WiFi 2.4 GHz (DSSS-OFDM, 18 Mbps, 90pc duty cycle)	WLAN	8.49	±9.6
10579	AAA	IEEE 802.11g WiFi 2.4 GHz (DSSS-OFDM, 24 Mbps, 90pc duty cycle)	WLAN	8.36	±9.6
10580	AAA	IEEE 802.11g WiFi 2.4 GHz (DSSS-OFDM, 36 Mbps, 90pc duty cycle)	WLAN	8.76	±9.6
10581	AAA	IEEE 802.11g WiFi 2.4 GHz (DSSS-OFDM, 48 Mbps, 90pc duty cycle)	WLAN	8.35	±9.6
10582	AAA	IEEE 802.11g WiFi 2.4 GHz (DSSS-OFDM, 54 Mbps, 90pc duty cycle)	WLAN	8.67	±9.6
10583	AAC	IEEE 802.11a/h WiFi 5 GHz (OFDM, 6 Mbps, 90pc duty cycle)	WLAN	8.59	±9.6
10584	AAC	IEEE 802.11a/h WiFi 5 GHz (OFDM, 9 Mbps, 90pc duty cycle)	WLAN	8.60	±9.6
10585	AAC	IEEE 802.11a/h WiFi 5 GHz (OFDM, 12 Mbps, 90pc duty cycle)	WLAN	8.70	±9.6
10586	AAC	IEEE 802.11a/h WiFi 5 GHz (OFDM, 18 Mbps, 90pc duty cycle)	WLAN	8.49	±9.6
10587	AAC	IEEE 802.11a/h WiFi 5 GHz (OFDM, 24 Mbps, 90pc duty cycle)	WLAN	8.36	±9.6
10588	AAC	IEEE 802.11a/h WiFi 5 GHz (OFDM, 36 Mbps, 90pc duty cycle)	WLAN	8.76	±9.6
10589	AAC	IEEE 802.11a/h WiFi 5 GHz (OFDM, 48 Mbps, 90pc duty cycle)	WLAN	8.35	±9.6
10590	AAC	IEEE 802.11a/h WiFi 5 GHz (OFDM, 54 Mbps, 90pc duty cycle)	WLAN	8.67	±9.6
10591	AAC	IEEE 802.11n (HT Mixed, 20 MHz, MCS0, 90pc duty cycle)	WLAN	8.63	±9.6
10592	AAC	IEEE 802.11n (HT Mixed, 20 MHz, MCS1, 90pc duty cycle)	WLAN	8.79	±9.6
10593	AAC	IEEE 802.11n (HT Mixed, 20 MHz, MCS2, 90pc duty cycle)	WLAN	8.64	±9.6
10594	AAC	IEEE 802.11n (HT Mixed, 20 MHz, MCS3, 90pc duty cycle)	WLAN	8.74	±9.6
10595	AAC	IEEE 802.11n (HT Mixed, 20 MHz, MCS4, 90pc duty cycle)	WLAN	8.74	±9.6
10596	AAC	IEEE 802.11n (HT Mixed, 20 MHz, MCS5, 90pc duty cycle)	WLAN	8.71	±9.6
10597	AAC	IEEE 802.11n (HT Mixed, 20 MHz, MCS6, 90pc duty cycle)	WLAN	8.72	±9.6
10598	AAC	IEEE 802.11n (HT Mixed, 20 MHz, MCS7, 90pc duty cycle)	WLAN	8.50	±9.6
10599	AAC	IEEE 802.11n (HT Mixed, 40 MHz, MCS0, 90pc duty cycle)	WLAN	8.79	±9.6
10600	AAC	IEEE 802.11n (HT Mixed, 40 MHz, MCS1, 90pc duty cycle)	WLAN	8.88	±9.6
10601	AAC	IEEE 802.11n (HT Mixed, 40 MHz, MCS2, 90pc duty cycle)	WLAN	8.82	±9.6
10602	AAC	IEEE 802.11n (HT Mixed, 40 MHz, MCS3, 90pc duty cycle)	WLAN	8.94	±9.6
10603	AAC	IEEE 802.11n (HT Mixed, 40 MHz, MCS4, 90pc duty cycle)	WLAN	9.03	±9.6
10604	AAC	IEEE 802.11n (HT Mixed, 40 MHz, MCS5, 90pc duty cycle)	WLAN	8.76	±9.6
10605	AAC	IEEE 802.11n (HT Mixed, 40 MHz, MCS6, 90pc duty cycle)	WLAN	8.97	±9.6
10606	AAC	IEEE 802.11n (HT Mixed, 40 MHz, MCS7, 90pc duty cycle)	WLAN	8.82	±9.6
10607	AAC	IEEE 802.11ac WiFi (20 MHz, MCS0, 90pc duty cycle)	WLAN	8.64	±9.6
10608	AAC	IEEE 802.11ac WiFi (20 MHz, MCS1, 90pc duty cycle)	WLAN	8.77	±9.6



EX3DV4 - SN:3759

December 15, 2022

UID	Rev	Communication System Name	Group	PAR (dB)	Unc ^E k = 2
10609	AAC	IEEE 802.11ac WiFi (20 MHz, MCS2, 90pc duty cycle)	WLAN	8.57	±9.6
10610	AAC	IEEE 802.11ac WiFi (20 MHz, MCS3, 90pc duty cycle)	WLAN	8.78	±9.6
10611	AAC	IEEE 802.11ac WiFi (20 MHz, MCS4, 90pc duty cycle)	WLAN	8.70	±9.6
10612	AAC	IEEE 802.11ac WiFi (20 MHz, MCS5, 90pc duty cycle)	WLAN	8.77	±9.6
10613	AAC	IEEE 802.11ac WiFi (20 MHz, MCS6, 90pc duty cycle)	WLAN	8.94	±9.6
10614	AAC	IEEE 802.11ac WiFi (20 MHz, MCS7, 90pc duty cycle)	WLAN	8.59	±9.6
10615	AAC	IEEE 802.11ac WiFi (20 MHz, MCS8, 90pc duty cycle)	WLAN	8.82	±9.6
10616	AAC	IEEE 802.11ac WiFi (40 MHz, MCS0, 90pc duty cycle)	WLAN	8.82	±9.6
10617	AAC	IEEE 802.11ac WiFi (40 MHz, MCS1, 90pc duty cycle)	WLAN	8.81	±9.6
10618	AAC	IEEE 802.11ac WiFi (40 MHz, MCS2, 90pc duty cycle)	WLAN	8.58	±9.6
10619	AAC	IEEE 802.11ac WiFi (40 MHz, MCS3, 90pc duty cycle)	WLAN	8.86	±9.6
10620	AAC	IEEE 802.11ac WiFi (40 MHz, MCS4, 90pc duty cycle)	WLAN	8.87	±9.6
10621	AAC	IEEE 802.11ac WiFi (40 MHz, MCS5, 90pc duty cycle)	WLAN	8.77	±9.6
10622	AAC	IEEE 802.11ac WiFi (40 MHz, MCS6, 90pc duty cycle)	WLAN	8.68	±9.6
10623	AAC	IEEE 802.11ac WiFi (40 MHz, MCS7, 90pc duty cycle)	WLAN	8.82	±9.6
10624	AAC	IEEE 802.11ac WiFi (40 MHz, MCS8, 90pc duty cycle)	WLAN	8.96	±9.6
10625	AAC	IEEE 802.11ac WiFi (40 MHz, MCS9, 90pc duty cycle)	WLAN	8.96	±9.6
10626	AAC	IEEE 802.11ac WiFi (80 MHz, MCS0, 90pc duty cycle)	WLAN	8.83	±9.6
10627	AAC	IEEE 802.11ac WiFi (80 MHz, MCS1, 90pc duty cycle)	WLAN	8.88	±9.6
10628	AAC	IEEE 802.11ac WiFi (80 MHz, MCS2, 90pc duty cycle)	WLAN	8.71	±9.6
10629	AAC	IEEE 802.11ac WiFi (80 MHz, MCS3, 90pc duty cycle)	WLAN	8.85	±9.6
10630	AAC	IEEE 802.11ac WiFi (80 MHz, MCS4, 90pc duty cycle)	WLAN	8.72	±9.6
10631	AAC	IEEE 802.11ac WiFi (80 MHz, MCS5, 90pc duty cycle)	WLAN	8.81	±9.6
10632	AAC	IEEE 802.11ac WiFi (80 MHz, MCS6, 90pc duty cycle)	WLAN	8.74	±9.6
10633	AAC	IEEE 802.11ac WiFi (80 MHz, MCS7, 90pc duty cycle)	WLAN	8.83	±9.6
10634	AAC	IEEE 802.11ac WiFi (80 MHz, MCS8, 90pc duty cycle)	WLAN	8.80	±9.6
10635	AAC	IEEE 802.11ac WiFi (80 MHz, MCS9, 90pc duty cycle)	WLAN	8.81	±9.6
10636	AAD	IEEE 802.11ac WiFi (160 MHz, MCS0, 90pc duty cycle)	WLAN	8.83	±9.6
10637	AAD	IEEE 802.11ac WiFi (160 MHz, MCS1, 90pc duty cycle)	WLAN	8.79	±9.6
10638	AAD	IEEE 802.11ac WiFi (160 MHz, MCS2, 90pc duty cycle)	WLAN	8.86	±9.6
10639	AAD	IEEE 802.11ac WiFi (160 MHz, MCS3, 90pc duty cycle)	WLAN	8.85	±9.6
10640	AAD	IEEE 802.11ac WiFi (160 MHz, MCS4, 90pc duty cycle)	WLAN	8.98	±9.6
10641	AAD	IEEE 802.11ac WiFi (160 MHz, MCS5, 90pc duty cycle)	WLAN	9.06	±9.6
10642	AAD	IEEE 802.11ac WiFi (160 MHz, MCS6, 90pc duty cycle)	WLAN	9.06	±9.6
10643	AAD	IEEE 802.11ac WiFi (160 MHz, MCS7, 90pc duty cycle)	WLAN	8.89	±9.6
10644	AAD	IEEE 802.11ac WiFi (160 MHz, MCS8, 90pc duty cycle)	WLAN	9.05	±9.6
10645	AAD	IEEE 802.11ac WiFi (160 MHz, MCS9, 90pc duty cycle)	WLAN	9.11	±9.6
10646	AAH	LTE-TDD (SC-FDMA, 1 RB, 5 MHz, QPSK, UL Subframe=2,7)	LTE-TDD	11.96	±9.6
10647	AAG	LTE-TDD (SC-FDMA, 1 RB, 20 MHz, QPSK, UL Subframe=2,7)	LTE-TDD	11.96	±9.6
10648	AAA	CDMA2000 (1x Advanced)	CDMA2000	3.45	±9.6
10652	AAF	LTE-TDD (OFDMA, 5 MHz, E-TM 3.1, Clipping 44%)	LTE-TDD	6.91	±9.6
10653	AAF	LTE-TDD (OFDMA, 10 MHz, E-TM 3.1, Clipping 44%)	LTE-TDD	7.42	±9.6
10654	AAE	LTE-TDD (OFDMA, 15 MHz, E-TM 3.1, Clipping 44%)	LTE-TDD	6.96	±9.6
10655	AAF	LTE-TDD (OFDMA, 20 MHz, E-TM 3.1, Clipping 44%)	LTE-TDD	7.21	±9.6
10658	AAB	Pulse Waveform (200Hz, 10%)	Test	10.00	±9.6
10659	AAB	Pulse Waveform (200Hz, 20%)	Test	6.99	±9.6
10660	AAB	Pulse Waveform (200Hz, 40%)	Test	3.98	±9.6
10661	AAB	Pulse Waveform (200Hz, 60%)	Test	2.22	±9.6
10662	AAB	Pulse Waveform (200Hz, 80%)	Test	0.97	±9.6
10670	AAA	Bluetooth Low Energy	Bluetooth	2.19	±9.6
10671	AAC	IEEE 802.11ax (20 MHz, MCS0, 90pc duty cycle)	WLAN	9.09	±9.6
10672	AAC	IEEE 802.11ax (20 MHz, MCS1, 90pc duty cycle)	WLAN	8.57	±9.6
10673	AAC	IEEE 802.11ax (20 MHz, MCS2, 90pc duty cycle)	WLAN	8.78	±9.6
10674	AAC	IEEE 802.11ax (20 MHz, MCS3, 90pc duty cycle)	WLAN	8.74	±9.6
10675	AAC	IEEE 802.11ax (20 MHz, MCS4, 90pc duty cycle)	WLAN	8.90	±9.6
10676	AAC	IEEE 802.11ax (20 MHz, MCS5, 90pc duty cycle)	WLAN	8.77	±9.6
10677	AAC	IEEE 802.11ax (20 MHz, MCS6, 90pc duty cycle)	WLAN	8.73	±9.6
10678	AAC	IEEE 802.11ax (20 MHz, MCS7, 90pc duty cycle)	WLAN	8.78	±9.6
10679	AAC	IEEE 802.11ax (20 MHz, MCS8, 90pc duty cycle)	WLAN	8.89	±9.6
10680	AAC	IEEE 802.11ax (20 MHz, MCS9, 90pc duty cycle)	WLAN	8.80	±9.6
10681	AAC	IEEE 802.11ax (20 MHz, MCS10, 90pc duty cycle)	WLAN	8.62	±9.6
10682	AAC	IEEE 802.11ax (20 MHz, MCS11, 90pc duty cycle)	WLAN	8.83	±9.6
10683	AAC	IEEE 802.11ax (20 MHz, MCS0, 99pc duty cycle)	WLAN	8.42	±9.6
10684	AAC	IEEE 802.11ax (20 MHz, MCS1, 99pc duty cycle)	WLAN	8.26	±9.6
10685	AAC	IEEE 802.11ax (20 MHz, MCS2, 99pc duty cycle)	WLAN	8.33	±9.6
10686	AAC	IEEE 802.11ax (20 MHz, MCS3, 99pc duty cycle)	WLAN	8.28	±9.6