

# TEST REPORT

**Test Report No. :** UL-RPT-RP14614877JD02C

**Customer** : Apple Inc.  
**Model No. / HVIN** : A2873  
**PMN** : iMac  
**FCC ID** : BCGA2873  
**ISED Certification No.** : IC: 579C-A2873  
**Technology** : *Bluetooth* – BDR & EDR (Low Power Mode)  
**Test Standard(s)** : FCC Parts 15.209(a) & 15.247  
Innovation, Science and Economic Development Canada  
RSS-247 Issue 2 February 2017  
RSS-Gen Issue 5 February 2021  
**Test Laboratory** : UL International (UK) Ltd, Basingstoke, Hampshire, RG24 8AH,  
United Kingdom

1. This test report shall not be reproduced except in full, without the written approval of UL International (UK) Ltd.
2. The results in this report apply only to the sample(s) tested.
3. The sample tested is in compliance with the above standard(s).
4. The test results in this report are traceable to the national or international standards.
5. Version 1.0.

**Date of Issue:** 18 April 2023

**Checked by:**   
Sarah Williams  
RF Operations Leader, Radio Laboratory

**Company Signatory:**   
Ben Mercer  
Lead Project Engineer, Radio Laboratory



The *Bluetooth*® word mark and logos are owned by the *Bluetooth* SIG, Inc. and any use of such marks by UL International (UK) Ltd is under licence. Other trademarks and trade names are those of their respective owners.

**UL International (UK) LTD**

Unit 1-3 Horizon, Kingsland Business Park, Wade Road, Basingstoke, Hampshire, RG24 8AH, UK  
Telephone: +44 (0)1256 312000

**Customer Information**

<b>Company Name:</b>	Apple Inc.
<b>Address:</b>	One Apple Park Way Cupertino, California 95014 U.S.A.
<b>Contact Name:</b>	Stuart Thomas

**Report Revision History**

<b>Version Number</b>	<b>Issue Date</b>	<b>Revision Details</b>	<b>Revised By</b>
1.0	18/04/2023	Initial Version	Sarah Williams

**Table of Contents**

**Customer Information..... 2**

**Report Revision History ..... 2**

**Table of Contents..... 3**

**1 Attestation of Test Results..... 4**

    1.1 Description of EUT 4

    1.2 General Information 4

    1.3 Summary of Test Results 5

    1.4 Deviations from the Test Specification 5

**2 Summary of Testing..... 6**

    2.1 Facilities and Accreditation 6

    2.2 Methods and Procedures 6

    2.3 Calibration and Uncertainty 7

    2.4 Test and Measurement Equipment 8

**3 Equipment Under Test (EUT) .....10**

    3.1 Identification of Equipment Under Test (EUT) 10

    3.2 Modifications Incorporated in the EUT 10

    3.3 Additional Information Related to Testing 11

    3.4 Description of Available Antennas 11

    3.5 Description of Test Setup 12

**4 Antenna Port Test Results .....18**

    4.1 Transmitter 99% Emission Bandwidth 18

    4.2 Transmitter 20 dB Bandwidth 31

    4.3 Transmitter Carrier Frequency Separation 44

    4.4 Transmitter Number of Hopping Frequencies and Average Time of Occupancy 54

    4.5 Transmitter Maximum Peak Output Power 58

**5 Radiated Test Results.....80**

    5.1 Transmitter Radiated Emissions <1 GHz 80

    5.2 Transmitter Radiated Emissions >1 GHz 82

    5.3 Transmitter Band Edge Radiated Emissions 84

**Appendix 1 .....133**

    FHSS Duty Cycle Correction Factor Calculation 133

## **1 Attestation of Test Results**

### **1.1 Description of EUT**

The equipment under test was an Apple desktop computer with Bluetooth® Low Energy, Thread and IEEE 802.11 a/b/g/n/ac/ax Wi-Fi capabilities in the 2.4 GHz, 5 GHz and 6 GHz bands.

### **1.2 General Information**

<b>Specification Reference:</b>	47CFR15.247
<b>Specification Title:</b>	Code of Federal Regulations Volume 47 (Telecommunications): Part 15 Subpart C (Intentional Radiators) – Section 15.247
<b>Specification Reference:</b>	47CFR15.209
<b>Specification Title:</b>	Code of Federal Regulations Volume 47 (Telecommunications): Part 15 Subpart C (Intentional Radiators) – Section 15.209
<b>Specification Reference:</b>	RSS-Gen Issue 5 February 2021
<b>Specification Title:</b>	General Requirements for Compliance of Radio Apparatus
<b>Specification Reference:</b>	RSS-247 Issue 2 February 2017
<b>Specification Title:</b>	Digital Transmission Systems (DTSs), Frequency Hopping Systems (FHSs) and Licence-Exempt Local Area Network (LE-LAN) Devices
<b>Site Registration:</b>	FCC: 685609, ISEDC: 20903
<b>FCC Lab. Designation No.:</b>	UK2011
<b>ISEDC CABID:</b>	UK0001
<b>Location of Testing:</b>	Unit 3 Horizon, Wade Road, Kingsland Business Park, Basingstoke, Hampshire, G24 8AH, United Kingdom
<b>Test Dates:</b>	04 January 2023 to 29 March 2023

### **1.3 Summary of Test Results**

<b>FCC Reference (47CFR)</b>	<b>ISED Canada Reference</b>	<b>Measurement</b>	<b>Result</b>
N/A	RSS-Gen 6.7	Transmitter 99% Occupied Bandwidth	Complied
Part 15.247(a)(1)	RSS-Gen 6.7 / RSS-247 5.1(a)	Transmitter 20 dB Bandwidth	Complied
Part 15.247(a)(1)	RSS-247 5.1(b)	Transmitter Carrier Frequency Separation	Complied
Part 15.247(a)(1)(iii)	RSS-247 5.1(d)	Transmitter Number of Hopping Frequencies and Average Time of Occupancy	Complied
Part 15.247(b)(1)	RSS-Gen 6.12 / RSS-247 5.4(b)	Transmitter Maximum Peak Output Power	Complied
Part 15.247(d) & 15.209(a)	RSS-Gen 6.13 / RSS-247 5.5	Transmitter Radiated Emissions	Complied
Part 15.247(d) & 15.209(a)	RSS-Gen 6.13 / RSS-247 5.5	Transmitter Band Edge Radiated Emissions	Complied

### **1.4 Deviations from the Test Specification**

For the measurements contained within this test report, there were no deviations from, additions to, or exclusions from the test specification identified above.

## **2 Summary of Testing**

### **2.1 Facilities and Accreditation**

The test site and measurement facilities used to collect data are located at Unit 3 Horizon, Wade Road, Kingsland Business Park, Basingstoke, Hampshire, RG24 8AH, United Kingdom. The following table identifies which facilities were utilised for radiated emission measurements documented in this report. Specific facilities are also identified in the test results sections.

Site 1	X
Site 2	-
Site 17	X

UL International (UK) Ltd is accredited by the United Kingdom Accreditation Service (UKAS). UKAS is one of the signatories to the International Laboratory Accreditation Co-operation (ILAC) Arrangement for the mutual recognition of test reports. The tests reported herein have been performed in accordance with its terms of accreditation.

### **2.2 Methods and Procedures**

<b>Reference:</b>	ANSI C63.10-2013
<b>Title:</b>	American National Standard of Procedures for Compliance Testing of Unlicensed Wireless Devices
<b>Reference:</b>	KDB 558074 D01 15.247 Meas Guidance v05r02, April 2, 2019
<b>Title:</b>	Guidance for Compliance Measurements on Digital Transmission System, Frequency Hopping Spread Spectrum System, and Hybrid System Devices Operating Under Section 15.247 of the FCC Rules
<b>Reference:</b>	KDB 662911 D01 Multiple Transmitter Output v02r01 October 31, 2013
<b>Title:</b>	Emissions Testing of Transmitters with Multiple Outputs in the Same Band

## **2.3 Calibration and Uncertainty**

### **Measuring Instrument Calibration**

In accordance with UKAS requirements all the measurement equipment is on a calibration schedule. All equipment was within the calibration period on the date of testing.

### **Measurement Uncertainty & Decision Rule**

#### **Overview**

No measurement or test can ever be perfect and the imperfections give rise to error of measurement in the results. Consequently the result of a measurement is only an approximation to the value of the measurand (the specific quantity subject to measurement) and is only complete when accompanied by a statement of the uncertainty of the approximation.

The expression of uncertainty of a measurement result allows realistic comparison of results with reference values and limits given in specifications and standards.

#### **Decision Rule**

The decision rule applied is based upon the accuracy method criteria. The measurement uncertainty is met and the result is considered in conformance with the requirement criteria if the observed value is within the prescribed limit.

#### **Measurement Uncertainty**

The reported expanded uncertainties below are based on a standard uncertainty multiplied by an appropriate coverage factor such that a confidence level of approximately 95% is maintained. For the purposes of this document “approximately” is interpreted as meaning “effectively” or “for most practical purposes”.

<b>Measurement Type</b>	<b>Range</b>	<b>Confidence Level (%)</b>	<b>Calculated Uncertainty</b>
99% Occupied Bandwidth	2.4 GHz to 2.4835 GHz	95%	±3.92 %
20 dB Bandwidth	2.4 GHz to 2.4835 GHz	95%	±4.59 %
Carrier Frequency Separation	2.4 GHz to 2.4835 GHz	95%	±4.59 %
Average Time of Occupancy	2.4 GHz to 2.4835 GHz	95%	±3.53 ns
Conducted Maximum Peak Output Power	2.4 GHz to 2.4835 GHz	95%	±1.13 dB
Radiated Spurious Emissions	9 kHz to 30 MHz	95%	±5.32 dB
Radiated Spurious Emissions	30 MHz to 1 GHz	95%	±3.30 dB
Radiated Spurious Emissions	1 GHz to 25 GHz	95%	±3.16 dB

The methods used to calculate the above uncertainties are in line with those recommended within the various measurement specifications. Where measurement specifications do not include guidelines for the evaluation of measurement uncertainty the published guidance of the appropriate accreditation body is followed.

## **2.4 Test and Measurement Equipment**

### **Test Equipment Used for Transmitter Conducted Tests**

<b>Asset No.</b>	<b>Instrument</b>	<b>Manufacturer</b>	<b>Type No.</b>	<b>Serial No.</b>	<b>Date Calibration Due</b>	<b>Cal. Interval (Months)</b>
M2001	Thermohygrometer	Testo	608-H1	45041824	09 Dec 2023	12
A3119	Attenuator	AtlanTecRF	AN18-10	237378#3	Calibrated before use	-
M2033	Signal Analyser	Rohde & Schwarz	FSV13	101667	11 Aug 2023	12
A214339	Attenuator	Atlantic Microwave	ATT06KXP-483082-S4S5	#4	Calibrated before use	-
A214340	Attenuator	Atlantic Microwave	ATT06KXP-483082-S4S5	#5	Calibrated before use	-
A214342	Attenuator	Atlantic Microwave	ATT06KXP-483082-S4S5	#7	Calibrated before use	-
A222202	Switch Box	UL	UK version #10010	#1	Calibrated before use	-
G0614	Signal Generator	Rohde & Schwarz	SMB100A	177687	19 May 2023	36



**Test and Measurement Equipment (continued)****Test Equipment Used for Transmitter Radiated Emissions Tests**

<b>Asset No.</b>	<b>Instrument</b>	<b>Manufacturer</b>	<b>Type No.</b>	<b>Serial No.</b>	<b>Date Calibration Due</b>	<b>Cal. Interval (Months)</b>
M2040	Thermohygrometer	Testo	608-H1	45124934	09 Dec 2023	12
K0001	3m RSE Chamber	Rainford EMC	N/A	N/A	05 Sep 2023	12
M2077	Test Receiver	Rohde & Schwarz	ESW44	102026	23 Feb 2024	12
A3165	Magnetic Loop Antenna	ETS-Lindgren	6502	00224383	05 May 2023	12
M2003	Thermohygrometer	Testo	608-H1	45046641	09 Dec 2023	12
K0017	3m RSE Chamber	Rainford EMC	N/A	N/A	08 Nov 2023	12
M1995	Test Receiver	Rohde & Schwarz	ESU40	100428	02 Nov 2023	12
A3167	Pre-Amplifier	Com-Power	PAM-103	18020010	02 Nov 2023	12
A2863	Pre-Amplifier	Agilent	8449B	3008A02100	07 Nov 2023	12
A223628	Pre-Amplifier	Atlantic Microwave	A-LNAKX-380116-S5S5	210837001	02 Nov 2023	12
A3265	Pre-Amplifier	Schwarzbeck	BBV 9721	9721-069	31 Oct 2023	12
A490	Antenna	Chase	CBL6111A	1590	06 Oct 2023	12
A2889	Antenna	Schwarzbeck	BBHA 9120 B	00653	02 Nov 2023	12
A2890	Antenna	Schwarzbeck	HWRD 750	014	02 Nov 2023	12
A2892	Antenna	Schwarzbeck	BBHA 9170	9170-727	31 Oct 2023	12
A2148	Attenuator	AtlanTecRF	AN18-06	090202-06	06 Oct 2023	12
A2916	Attenuator	AtlanTecRF	AN18W5-10	832827#2	25 Jan 2024	12
A3036	Low Pass Filter	AtlanTecRF	AFL-02000	15062902848	25 Jan 2024	12
A2914	High Pass Filter	AtlanTecRF	AFH-03000	2155	25 Jan 2024	12
A2947	High Pass Filter	AtlanTecRF	AFH-07000	1601900001	25 Jan 2024	12

**Test Equipment Used for Transmitter Band Edge Radiated Emissions Tests**

<b>Asset No.</b>	<b>Instrument</b>	<b>Manufacturer</b>	<b>Type No.</b>	<b>Serial No.</b>	<b>Date Calibration Due</b>	<b>Cal. Interval (Months)</b>
M2003	Thermohygrometer	Testo	608-H1	45046641	09 Dec 2023	12
K0017	3m RSE Chamber	Rainford EMC	N/A	N/A	08 Nov 2023	12
M1995	Test Receiver	Rohde & Schwarz	ESU40	100428	02 Nov 2023	12
A2863	Pre-Amplifier	Agilent	8449B	3008A02100	07 Nov 2023	12
A2889	Antenna	Schwarzbeck	BBHA 9120 B	00653	02 Nov 2023	12
A2916	Attenuator	AtlanTecRF	AN18W5-10	832827#2	25 Jan 2024	12

### **3 Equipment Under Test (EUT)**

#### **3.1 Identification of Equipment Under Test (EUT)**

<b>Brand Name:</b>	Apple
<b>Model Name or Number / HVIN:</b>	A2873
<b>PMN:</b>	iMac
<b>Test Sample Serial Number:</b>	NNYGG3YVCT ( <i>Conducted sample</i> )
<b>Hardware Version:</b>	REV 1.0
<b>Software Version:</b>	22E31550u
<b>FCC ID:</b>	BCGA2873
<b>ISED Canada Certification Number:</b>	IC: 579C-A2873
<b>Date of Receipt:</b>	27 February 2023

<b>Brand Name:</b>	Apple
<b>Model Name or Number / HVIN:</b>	A2873
<b>PMN:</b>	iMac
<b>Test Sample Serial Number:</b>	PCV91RX367 ( <i>Radiated sample</i> )
<b>Hardware Version:</b>	REV 1.0
<b>Software Version:</b>	22E31550u
<b>FCC ID:</b>	BCGA2873
<b>ISED Canada Certification Number:</b>	IC: 579C-A2873
<b>Date of Receipt:</b>	04 January 2023

#### **3.2 Modifications Incorporated in the EUT**

No modifications were applied to the EUT during testing.

### 3.3 Additional Information Related to Testing

<b>Technology Tested:</b>	<i>Bluetooth</i>		
<b>Type of Unit:</b>	Transceiver		
<b>Channel Spacing:</b>	1 MHz		
<b>Mode:</b>	Basic Rate	Enhanced Data Rate	
<b>Modulation:</b>	GFSK	$\pi/4$ -DQPSK	8DPSK
<b>Packet Type (Maximum Payload):</b>	DH5	2DH5	3DH5
<b>Data Rate (Mbit/s):</b>	1	2	3
<b>Power Supply Requirement(s):</b>	Nominal	12 VDC via 120 VAC 60 Hz adaptor	
<b>Maximum Conducted Output Power:</b>	16.3 dBm		
<b>Transmit Frequency Range:</b>	2400 MHz to 2483.5 MHz		
<b>Transmit Channels Tested:</b>	<b>Channel ID</b>	<b>Channel Number</b>	<b>Channel Frequency (MHz)</b>
	Bottom	0	2402
	Middle	39	2441
	Top	78	2480

### 3.4 Description of Available Antennas

The radio utilizes three integrated antennas, with the following maximum gains:

Antenna Port	Frequency Range (MHz)	Antenna Gain (dBi)
Core 0	2400 to 2480	2.9
Core 1	2400 to 2480	3.5
Dedicated Core	2400 to 2480	1.0

The EUT also supports TxBF with unequal gains and equal transmit powers. Calculations for directional gain were in accordance with KDB 662911 D01 v02r01 Section F)2)d)(i). Directional gain of Core 0 & Core 1 was calculated as:

$$N_{ANT} = 2, G_{Core0} = 2.9 \text{ dBi}, G_{Core1} = 3.5 \text{ dBi}$$

$$\begin{aligned} \text{Directional Gain} &= 10 \log \left[ \frac{\left( 10^{\frac{G_1}{20}} + 10^{\frac{G_2}{20}} + \dots + 10^{\frac{G_N}{20}} \right)^2}{N_{ANT}} \right] = 10 \log \left[ \frac{\left( 10^{\frac{G_1}{20}} + 10^{\frac{G_2}{20}} \right)^2}{2} \right] \\ &= 10 \log \left[ \frac{\left( 10^{\frac{2.9}{20}} + 10^{\frac{3.5}{20}} \right)^2}{2} \right] = 6.2 \text{ dBi} \end{aligned}$$

### **3.5 Description of Test Setup**

#### **Support Equipment**

The following support equipment was used to exercise the EUT during testing:

<b>Description:</b>	Power Adaptor
<b>Brand Name:</b>	Apple
<b>Model Name or Number:</b>	A2290
<b>Serial Number:</b>	Not marked or stated

<b>Description:</b>	Test Laptop
<b>Brand Name:</b>	Apple
<b>Model Name or Number:</b>	MacBook Pro
<b>Serial Number:</b>	C02YK003L59F

<b>Description:</b>	USB Diagnostic Cable
<b>Brand Name:</b>	Apple
<b>Model Name or Number:</b>	Chimp
<b>Serial Number:</b>	30A99B

<b>Description:</b>	Test Laptop
<b>Brand Name:</b>	Apple
<b>Model Name or Number:</b>	MacBook Pro
<b>Serial Number:</b>	C02C800FP0CW

<b>Description:</b>	USB Diagnostic Cable
<b>Brand Name:</b>	Apple
<b>Model Name or Number:</b>	Chimp
<b>Serial Number:</b>	428A48

<b>Description:</b>	Personal Hands Free (PHF)
<b>Brand Name:</b>	Not marked or stated
<b>Model Name or Number:</b>	Not marked or stated
<b>Serial Number:</b>	Not marked or stated

<b>Description:</b>	USB-C to A Adaptor. Quantity 4. Length 10 cm.
<b>Brand Name:</b>	Not marked or stated
<b>Model Name or Number:</b>	Not marked or stated
<b>Serial Number:</b>	Not marked or stated

**Support Equipment (continued)**

<b>Description:</b>	USB-A Cable. Quantity 4. Length 3 m.
<b>Brand Name:</b>	Not marked or stated
<b>Model Name or Number:</b>	Not marked or stated
<b>Serial Number:</b>	Not marked or stated

<b>Description:</b>	Ethernet cable. Quantity 1. Length 2.5 m
<b>Brand Name:</b>	Not marked or stated
<b>Model Name or Number:</b>	Not marked or stated
<b>Serial Number:</b>	Not marked or stated

<b>Description:</b>	Laptop
<b>Brand Name:</b>	Lenova
<b>Model Name or Number:</b>	L440 Thinkpad
<b>Serial Number:</b>	R9-019EA2 14/04

<b>Description:</b>	USB-C Docking Station
<b>Brand Name:</b>	Lenova
<b>Model Name or Number:</b>	LDC-G2 Thinkpad
<b>Serial Number:</b>	Not marked or stated

<b>Description:</b>	4 port USB Termination Hub
<b>Brand Name:</b>	Uni
<b>Model Name or Number:</b>	Not marked or stated
<b>Serial Number:</b>	Not marked or stated

## **Operating Modes**

The EUT was tested in the following operating mode(s):

- Continuously transmitting at maximum power on bottom, middle and top channels in BDR (DH5 packets) or EDR (2DH5 or 3DH5 packets) as required.
- Continuously transmitting at maximum power in hopping mode on all channels in BDR (DH5 packets) or EDR (2DH5 or 3DH5 packets) as required.

## **Configuration and Peripherals**

The EUT was tested in the following configuration(s):

- Controlled in test mode using a set of commands entered into a terminal application on the test laptop supplied by the customer. The commands were used to enable a continuous transmission and to select the test channels as required. The customer supplied a document containing the setup instructions.
- The EUT has a dedicated core (core 2), which operates in SISO mode only, in addition to two cores which operate in both SISO and TxBF modes. Core 0 & Core 1 are identical but have unequal gains therefore conducted tests have been performed on the Core with the highest antenna gain. Modes tested were:
  - DH5 / SISO / Core 1
  - 2DH5 / SISO / Core 1
  - 3DH5 / SISO / Core 1
  - DH5 / SISO / Core 2
  - 2DH5 / SISO / Core 2
  - 3DH5 / SISO / Core 2
  - DH5 / Beamforming / Core 0 + Core 1
  - 2DH5 / Beamforming / Core 0 + Core 1
  - 3DH5 / Beamforming / Core 0 + Core 1
- The customer supplied U.FL RF cables with the EUT in order to perform conducted measurements. This measured additional path loss was included in any path loss calculations.
- The EUT was powered from a 120 VAC 60 Hz single phase mains supply.
- Transmitter radiated spurious emissions tests were performed with the EUT transmitting in DH5 Core 0 + Core 1 mode, as this mode was found to transmit the highest power.
- Radiated spurious emissions and band edge tests were performed with the EUT in its normal orientation. All ports were terminated into suitable terminations and placed under the turntable.

**Test Setup Diagrams**

**Conducted Tests:**

**Test Setup for Transmitter Conducted Tests**

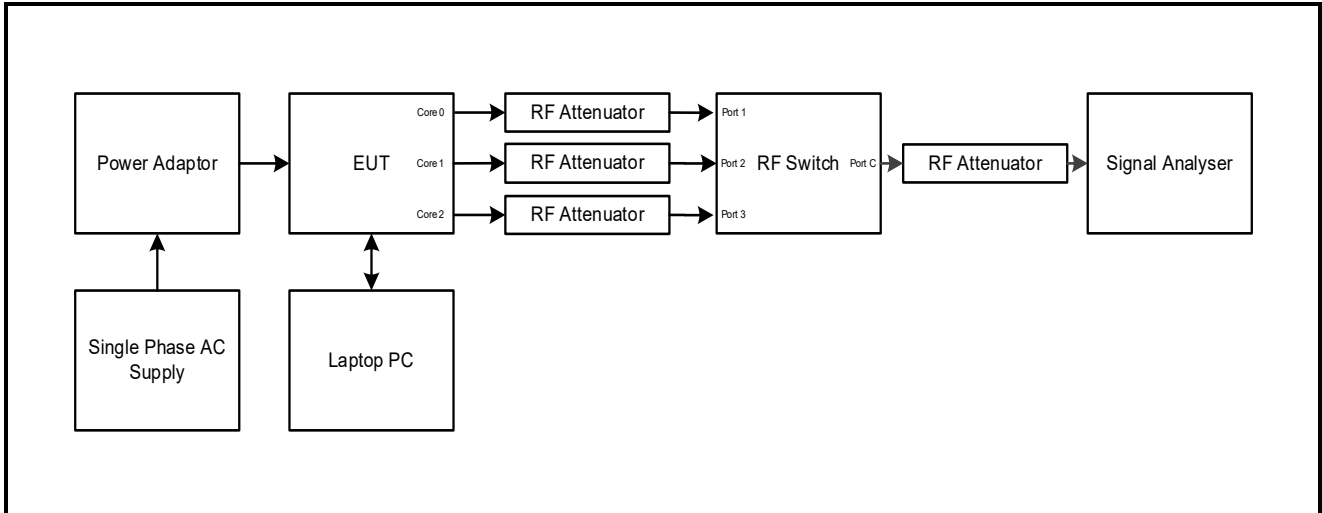

**Radiated Tests:**

**Test Setup for Transmitter Radiated Emissions**

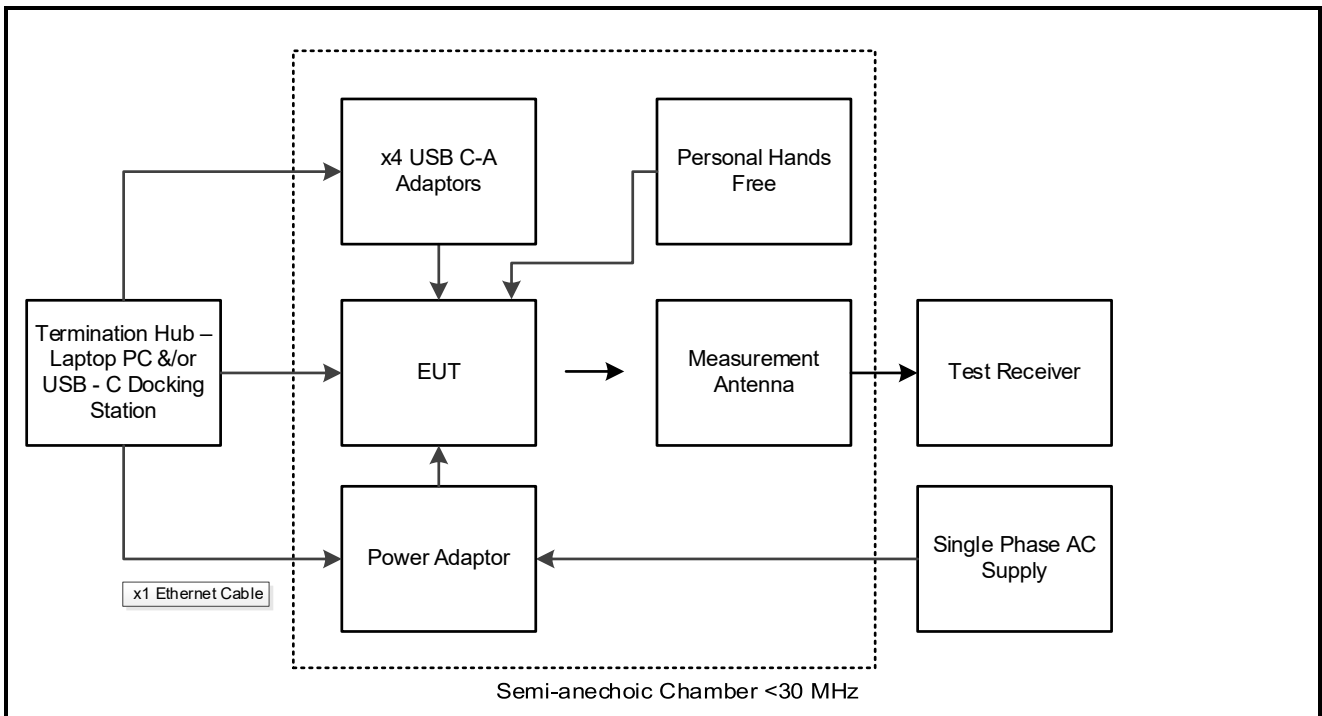

**Test Setup Diagrams (continued)**

**Radiated Tests:**

**Test Setup for Transmitter Radiated Emissions**

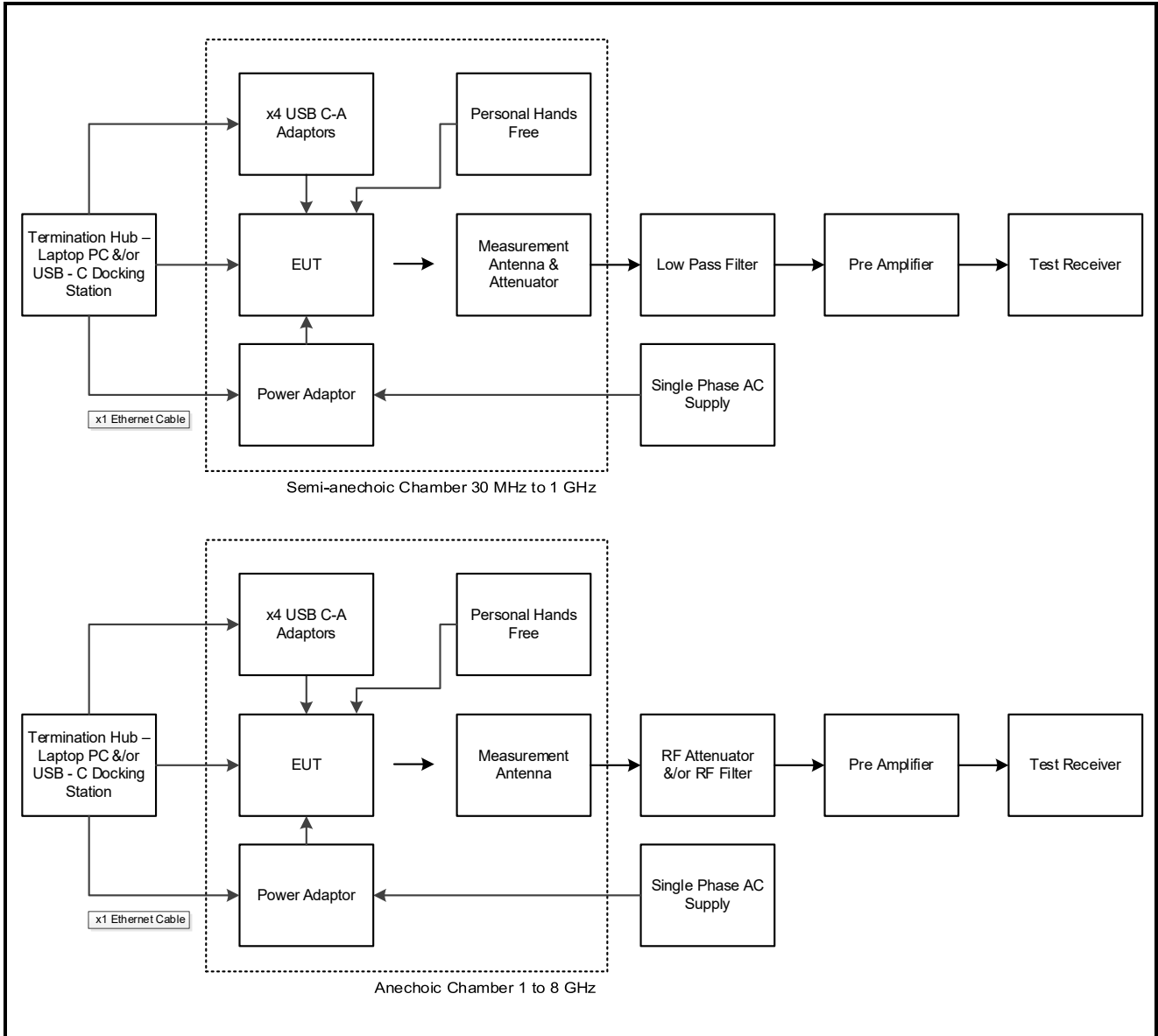



**Test Setup Diagrams (continued)**

**Test Setup for Transmitter Radiated Emissions (continued)**

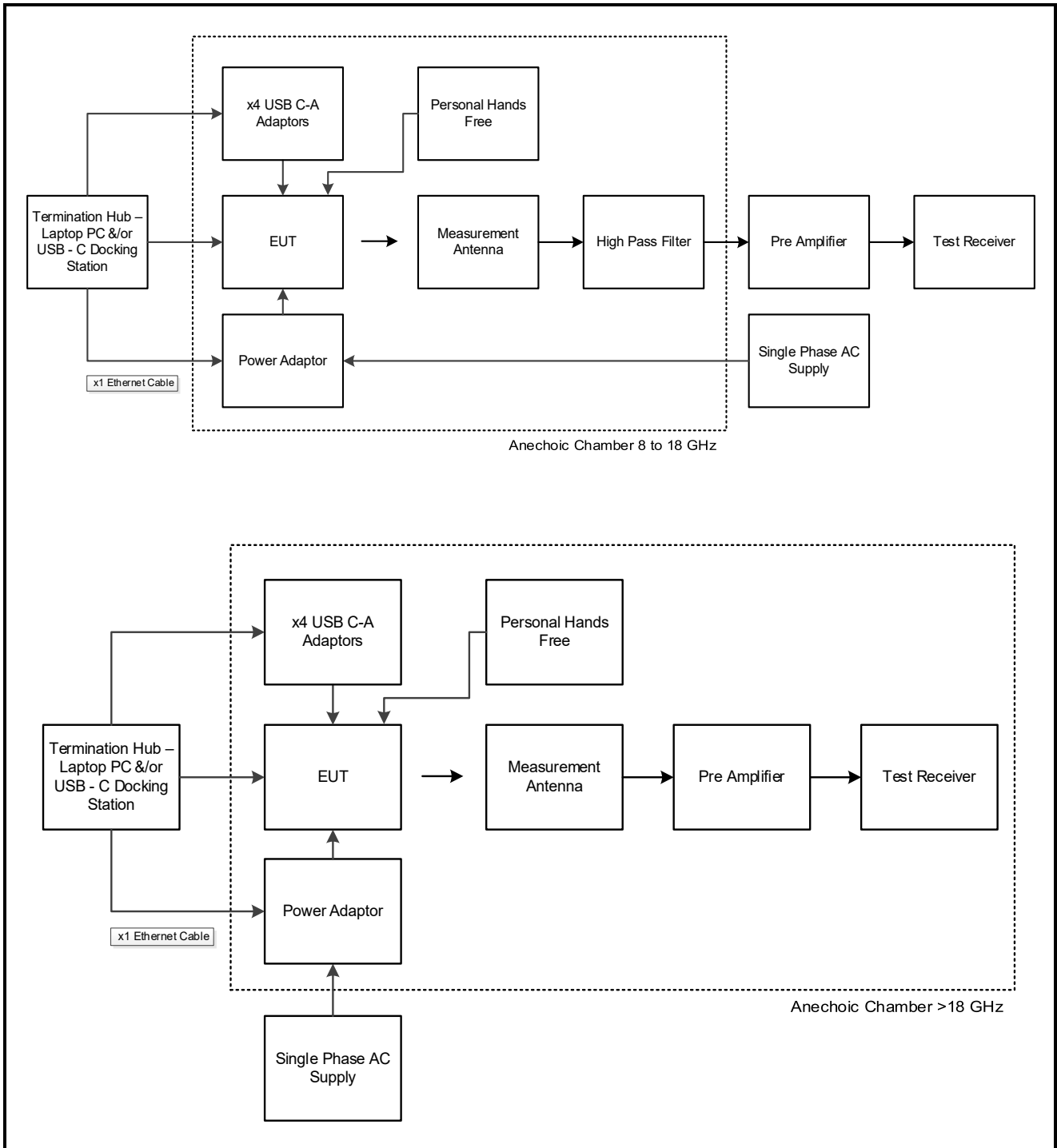

## **4 Antenna Port Test Results**

### **4.1 Transmitter 99% Emission Bandwidth**

#### **Test Summary:**

<b>Test Engineer:</b>	Raghavendra Katti	<b>Test Dates:</b>	16 March 2023 to 29 March 2023
<b>Test Sample Serial Number:</b>	NNYGG3YVCT		

<b>FCC Reference:</b>	N/A
<b>ISED Canada Reference:</b>	RSS-Gen 6.7
<b>Test Method Used:</b>	RSS-Gen 6.7 and Notes below

#### **Environmental Conditions:**

<b>Temperature (°C):</b>	23
<b>Relative Humidity (%):</b>	40 to 44

#### **Note(s):**

1. The 99% emission bandwidth was measured using the signal analyser occupied bandwidth function. The resolution bandwidth was set in the range of 1% to 5% of the occupied bandwidth and the video bandwidth set to 3 times the resolution bandwidth. The span was set to capture all products of the modulation process including emission skirts.
2. The signal analyser resolution bandwidth was set to 30 kHz and video bandwidth 100 kHz. A peak detector was used, sweep time was set to auto and the trace mode was Max Hold. The span was set to 5 MHz. The signal analyser function set the measurements to be made at 99% of the emission bandwidth. The results are given in the tables below.
3. The signal analyser was connected to the RF port on the EUT using suitable attenuation and RF cable.

**Transmitter 99% Emission Bandwidth (continued)**

**Results: DH5 / SISO / Core 1**

Channel	99% Emission Bandwidth (kHz)
Bottom	889.111
Middle	879.121
Top	899.101

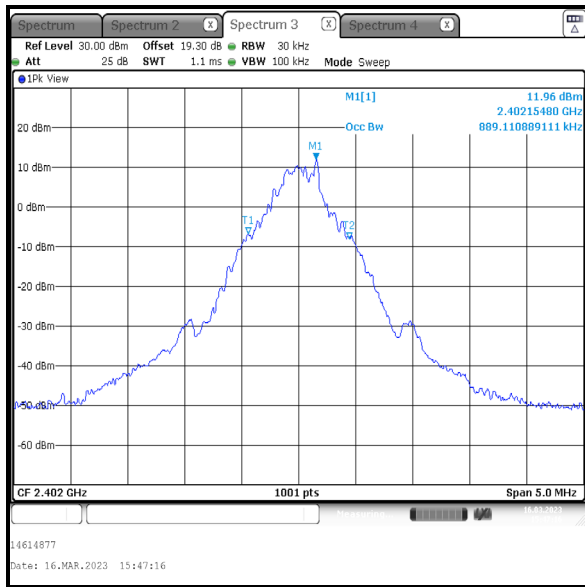

**Bottom Channel**

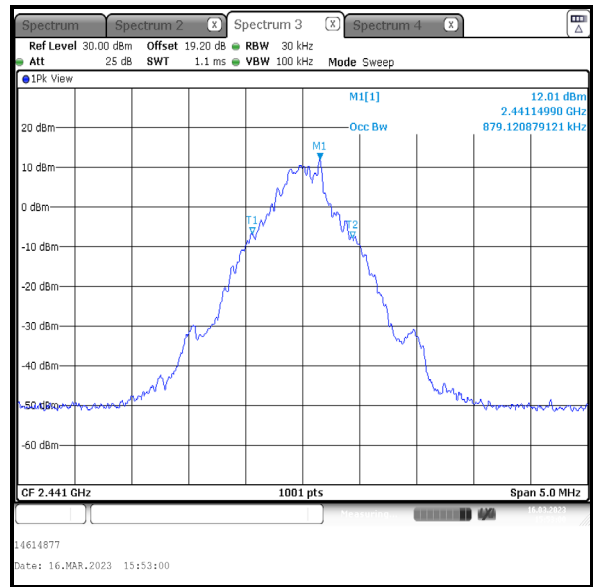

**Middle Channel**

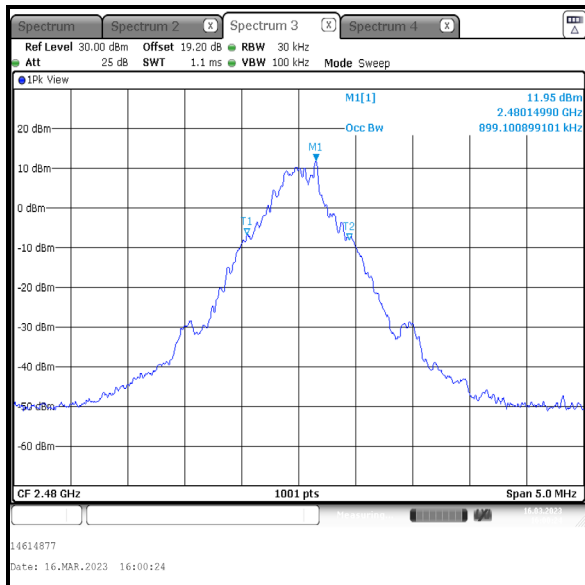

**Top Channel**

**Transmitter 99% Emission Bandwidth (continued)**

**Results: 2DH5 / SISO / Core 1**

Channel	99% Emission Bandwidth (kHz)
Bottom	1218.781
Middle	1223.776
Top	1218.781

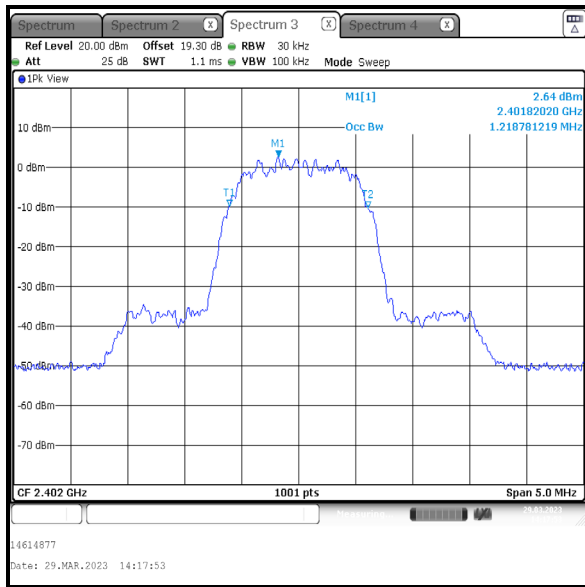

**Bottom Channel**

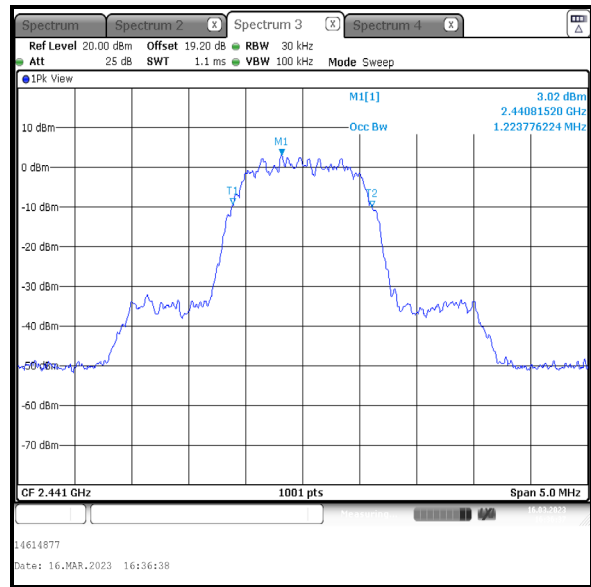

**Middle Channel**

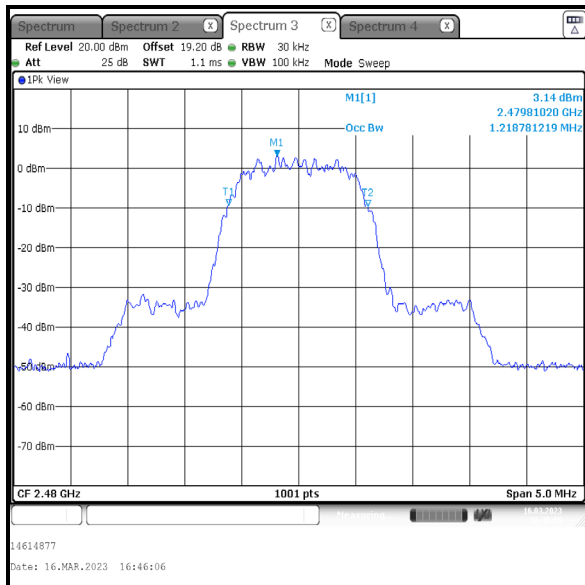

**Top Channel**

**Transmitter 99% Emission Bandwidth (continued)**

**Results: 3DH5 / SISO / Core 1**

Channel	99% Emission Bandwidth (kHz)
Bottom	1223.776
Middle	1223.776
Top	1223.776

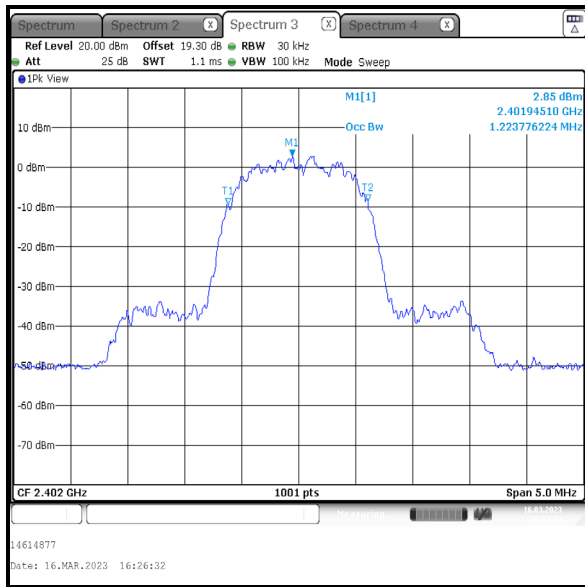

**Bottom Channel**

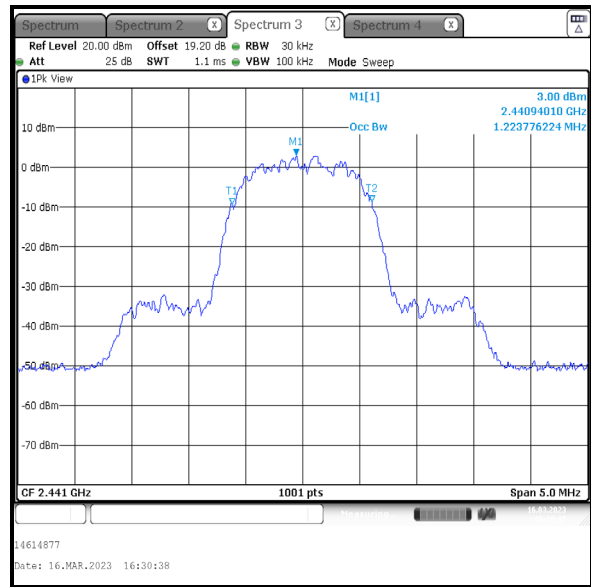

**Middle Channel**

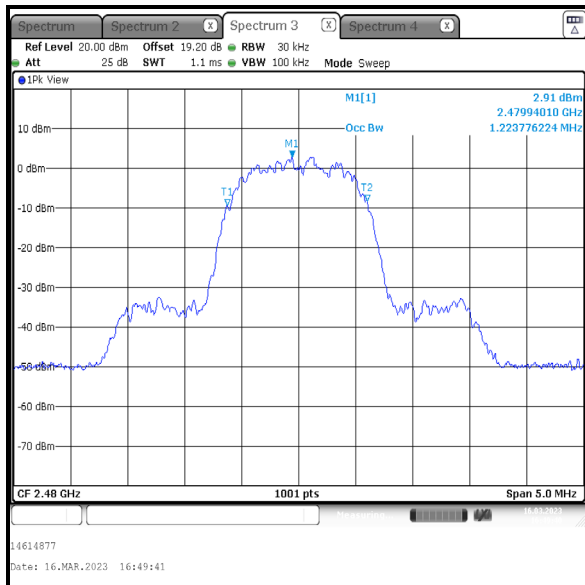

**Top Channel**

**Transmitter 99% Emission Bandwidth (continued)**

**Results: DH5 / SISO / Core 2**

Channel	99% Emission Bandwidth (kHz)
Bottom	879.121
Middle	884.116
Top	879.121

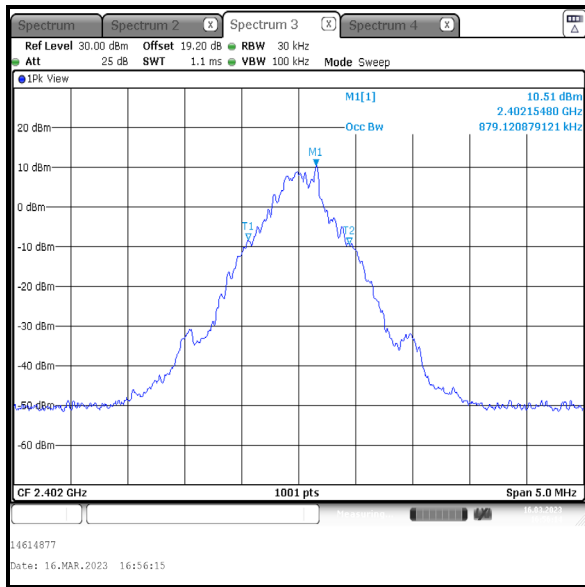

**Bottom Channel**

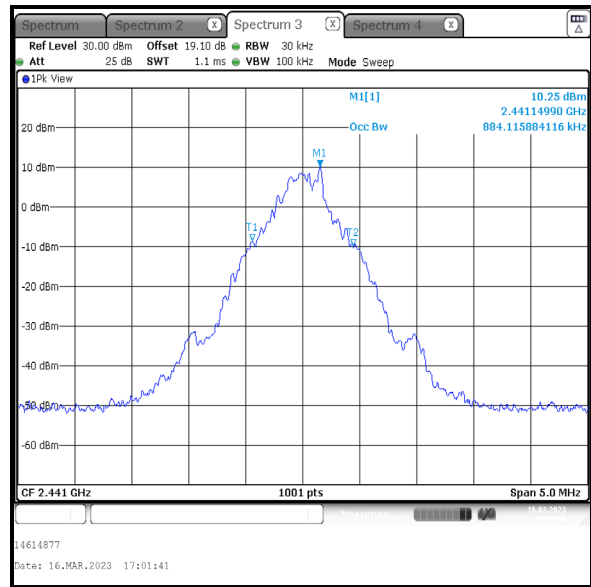

**Middle Channel**

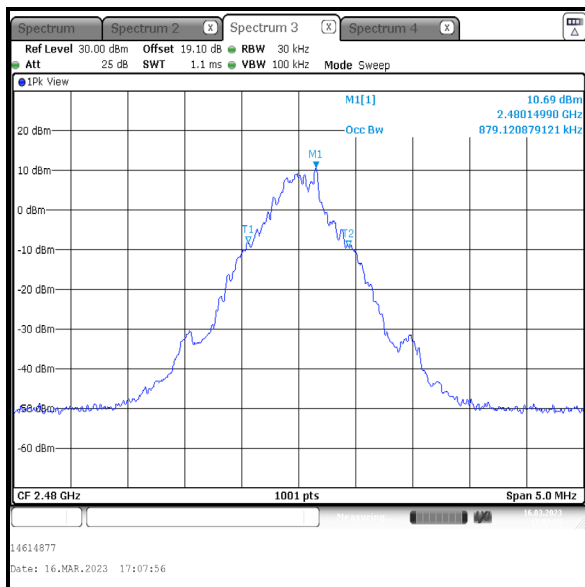

**Top Channel**

**Transmitter 99% Emission Bandwidth (continued)**

**Results: 2DH5 / SISO / Core 2**

Channel	99% Emission Bandwidth (kHz)
Bottom	1218.781
Middle	1213.786
Top	1218.941

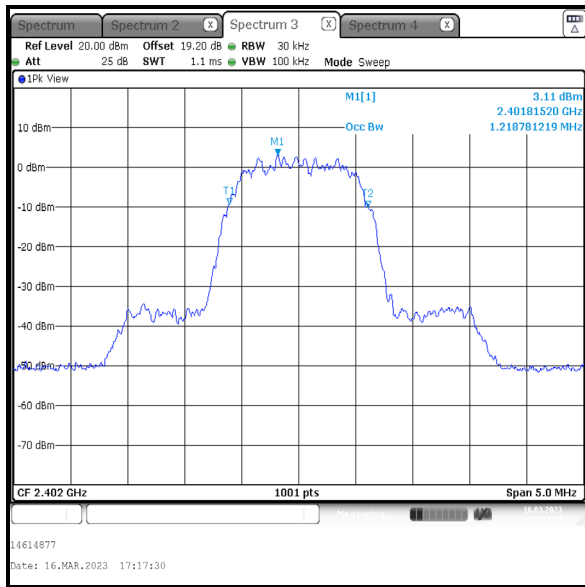

**Bottom Channel**

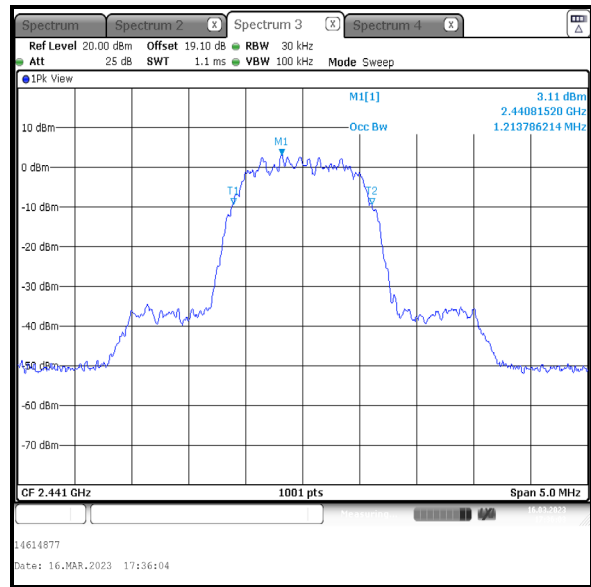

**Middle Channel**

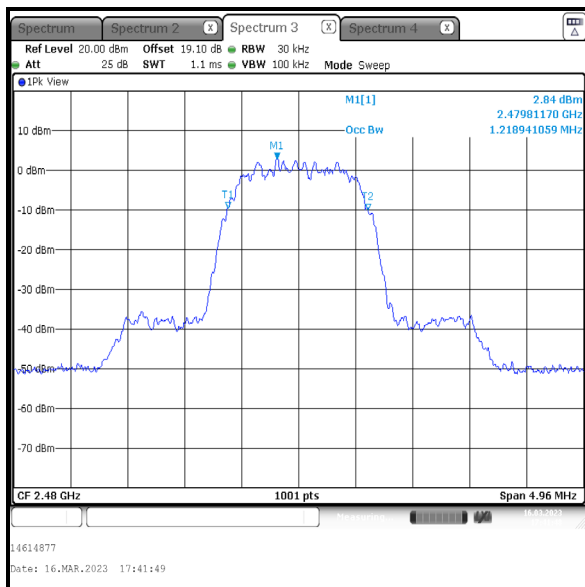

**Top Channel**

**Transmitter 99% Emission Bandwidth (continued)**

**Results: 3DH5 / SISO / Core 2**

Channel	99% Emission Bandwidth (kHz)
Bottom	1218.781
Middle	1218.781
Top	1218.941

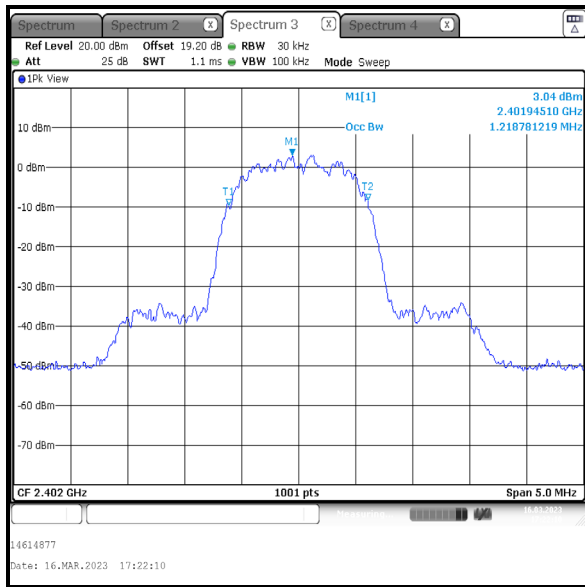

**Bottom Channel**

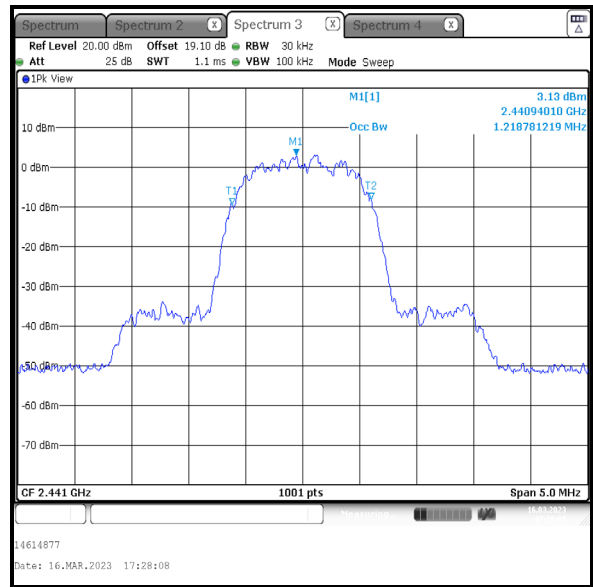

**Middle Channel**

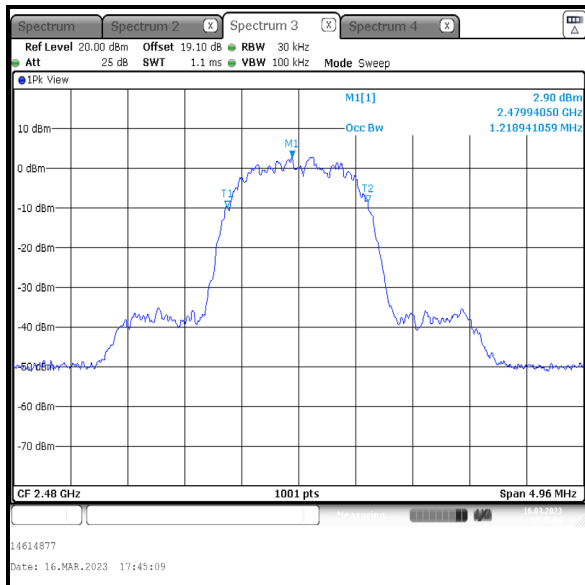

**Top Channel**



**Transmitter 99% Emission Bandwidth (continued)**

**Results: DH5 / Beamforming / Core 0**

Channel	99% Emission Bandwidth (kHz)
Bottom	879.121
Middle	879.121
Top	874.126

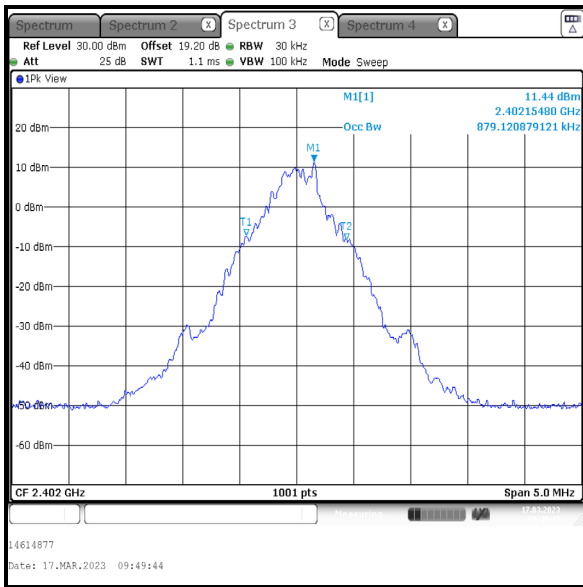

**Bottom Channel**

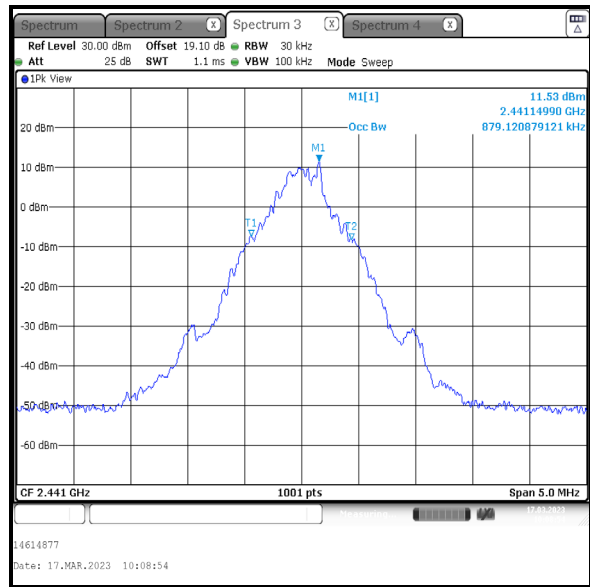

**Middle Channel**

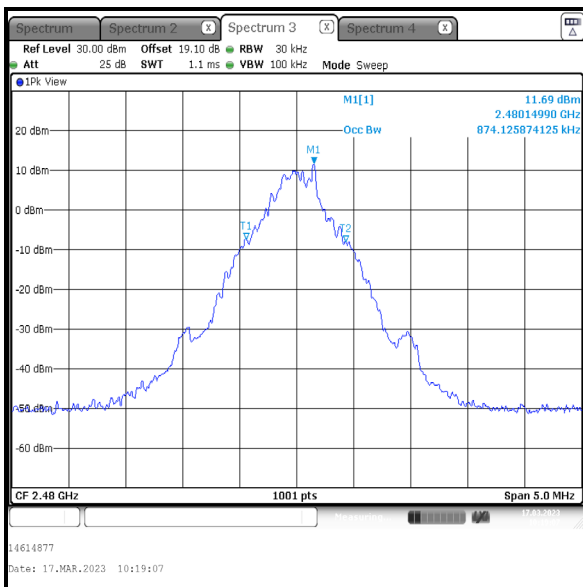

**Top Channel**

**Transmitter 99% Emission Bandwidth (continued)**

**Results: DH5 / Beamforming / Core 1**

Channel	99% Emission Bandwidth (kHz)
Bottom	884.116
Middle	889.111
Top	889.111

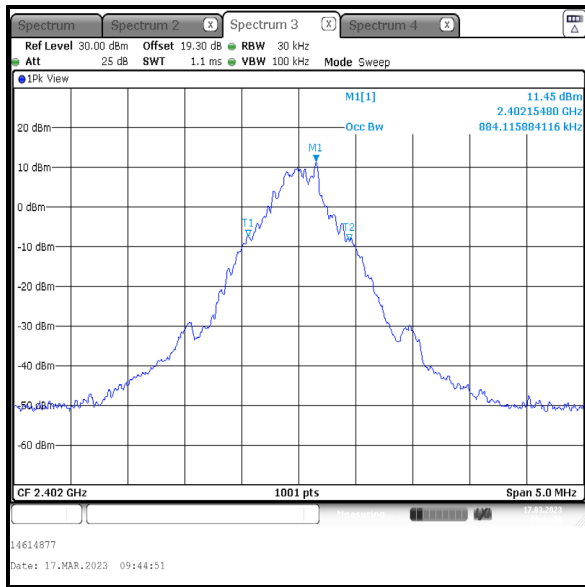

**Bottom Channel**

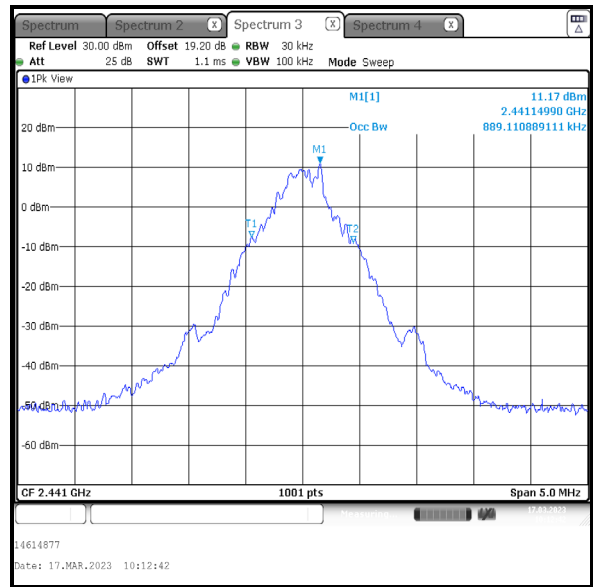

**Middle Channel**

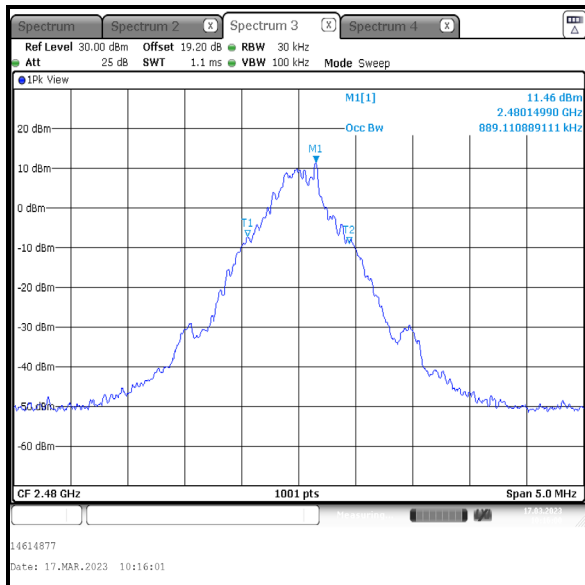

**Top Channel**

**Transmitter 99% Emission Bandwidth (continued)**

**Results: 2DH5 / Beamforming / Core 0**

Channel	99% Emission Bandwidth (kHz)
Bottom	1213.786
Middle	1213.786
Top	1213.786

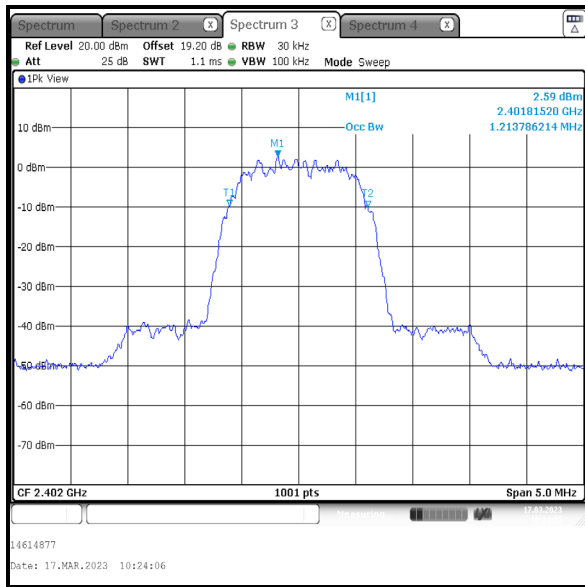

**Bottom Channel**

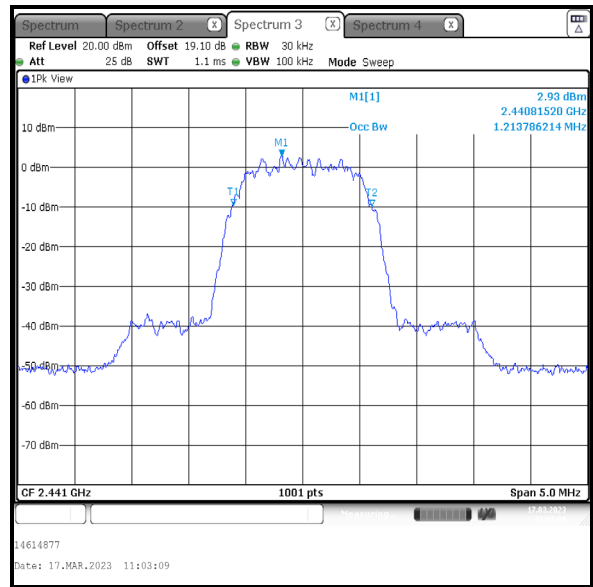

**Middle Channel**

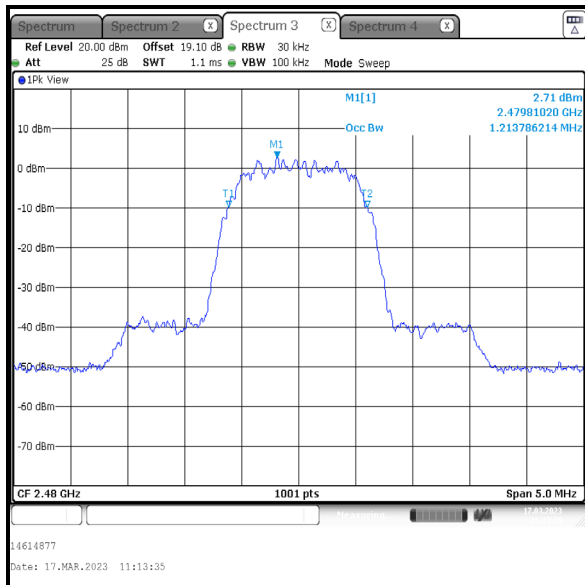

**Top Channel**

**Transmitter 99% Emission Bandwidth (continued)**

**Results: 2DH5 / Beamforming / Core 1**

Channel	99% Emission Bandwidth (kHz)
Bottom	1213.786
Middle	1213.786
Top	1218.781

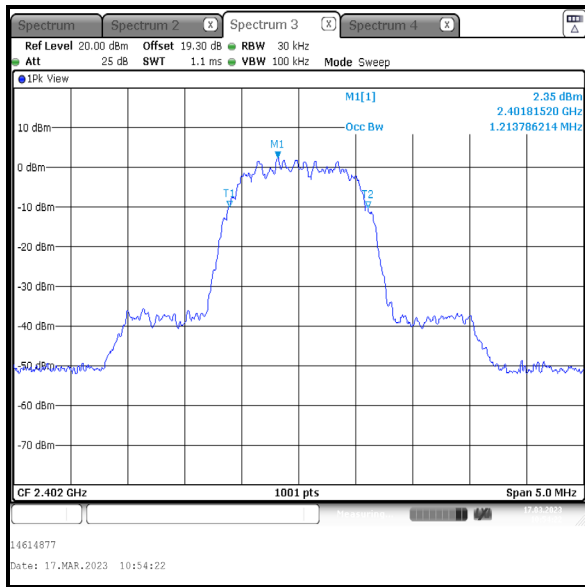

**Bottom Channel**

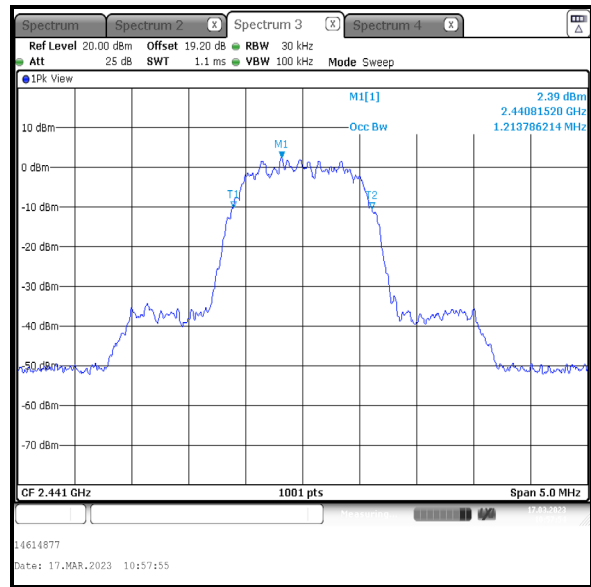

**Middle Channel**

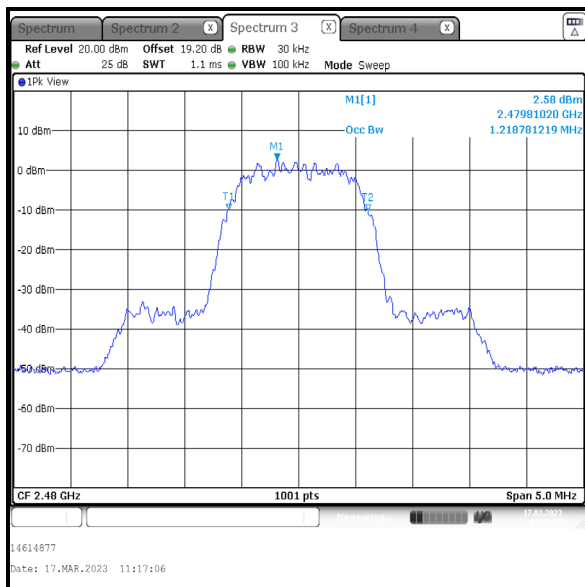

**Top Channel**

**Transmitter 99% Emission Bandwidth (continued)**

**Results: 3DH5 / Beamforming / Core 0**

Channel	99% Emission Bandwidth (kHz)
Bottom	1218.781
Middle	1213.786
Top	1218.781

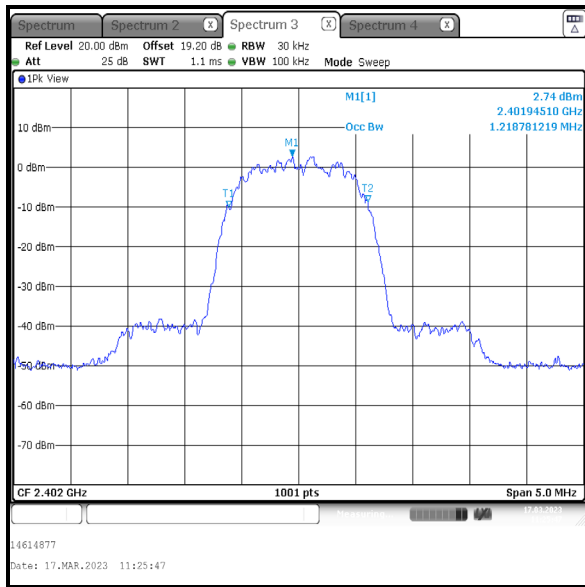

**Bottom Channel**

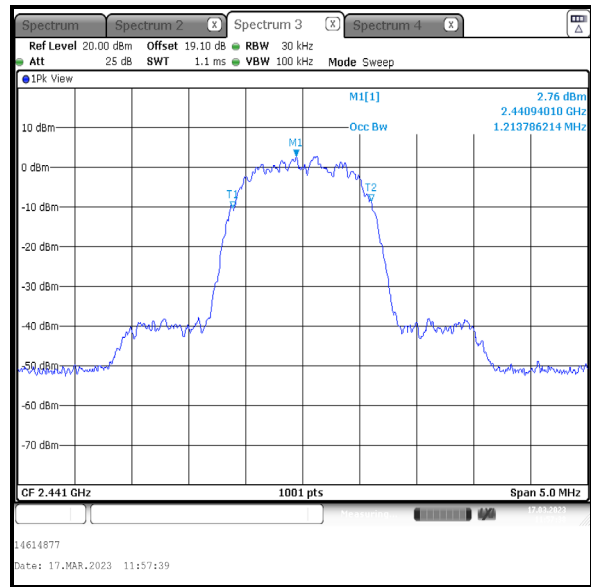

**Middle Channel**

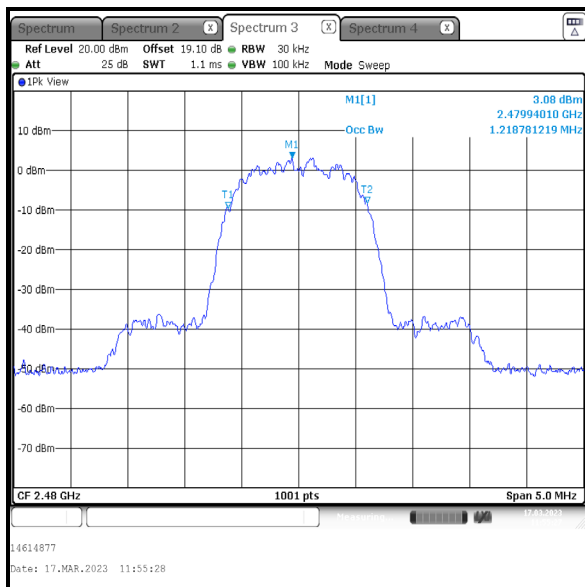

**Top Channel**

**Transmitter 99% Emission Bandwidth (continued)**

**Results: 3DH5 / Beamforming / Core 1**

Channel	99% Emission Bandwidth (kHz)
Bottom	1223.776
Middle	1218.781
Top	1223.776

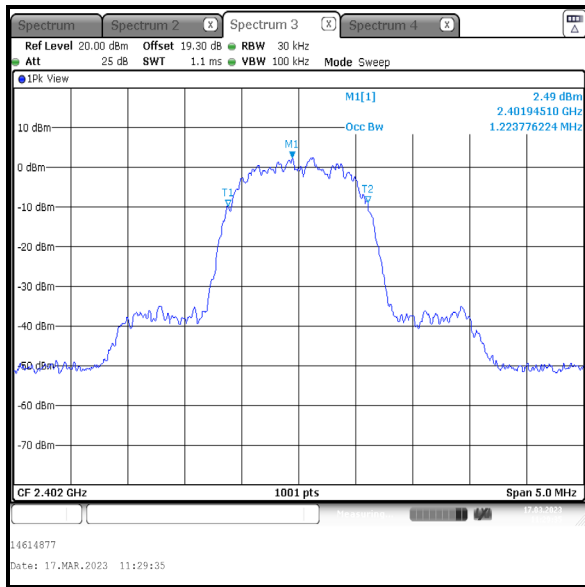

**Bottom Channel**

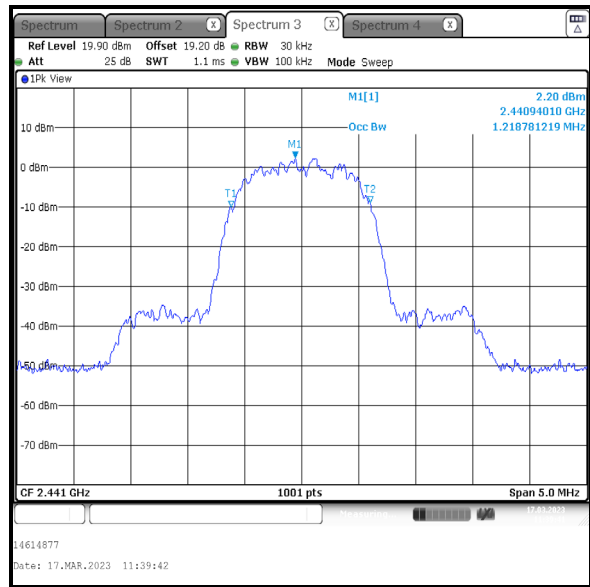

**Middle Channel**

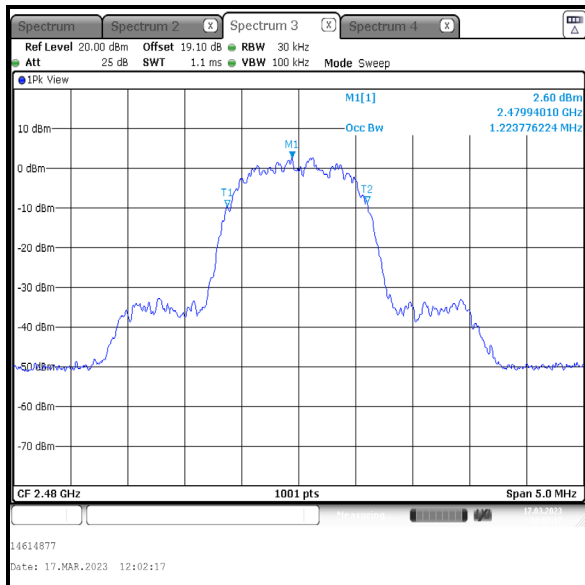

**Top Channel**

## **4.2 Transmitter 20 dB Bandwidth**

### **Test Summary:**

<b>Test Engineer:</b>	Raghavendra Katti	<b>Test Dates:</b>	16 March 2023 & 17 March 2023
<b>Test Sample Serial Number:</b>	NNYGG3YVCT		

<b>FCC Reference:</b>	Part 15.247(a)(1)
<b>ISED Canada Reference:</b>	RSS-Gen 6.7 / RSS-247 5.1(a)
<b>Test Method Used:</b>	ANSI C63.10 Section 6.9.2

### **Environmental Conditions:**

<b>Temperature (°C):</b>	23
<b>Relative Humidity (%):</b>	40 to 42

### **Note(s):**

1. The signal analyser resolution bandwidth was set to 30 kHz and video bandwidth 100 kHz. A peak detector was used, sweep time was set to auto and the trace mode was Max Hold. The span was set to 4 MHz. Normal and delta markers were placed 20 dB down from the peak of the carrier.
2. The signal analyser was connected to the RF port on the EUT using suitable attenuation and RF cable.

**Transmitter 20 dB Bandwidth (continued)**

**Results: DH5 / SISO / Core 1**

Channel	20 dB Bandwidth (kHz)
Bottom	943.100
Middle	935.100
Top	947.100

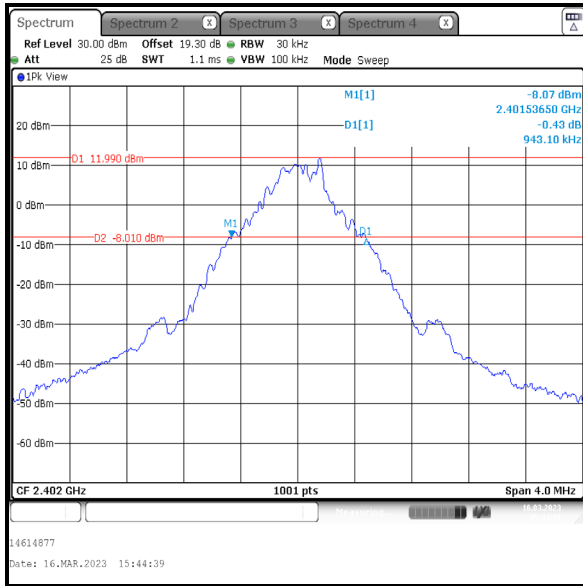

**Bottom Channel**

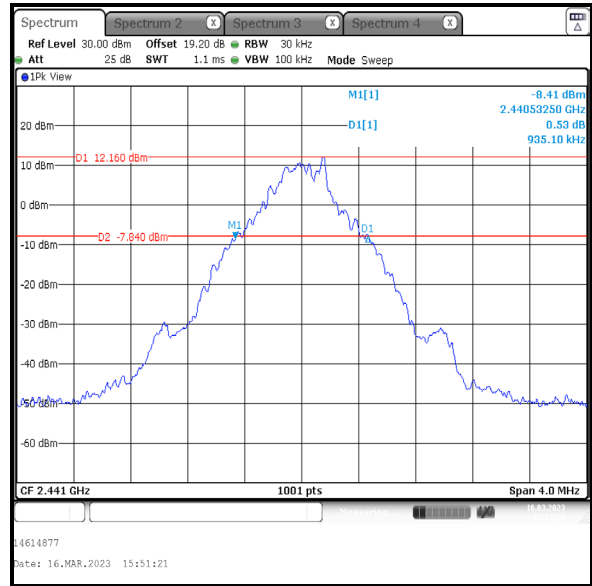

**Middle Channel**

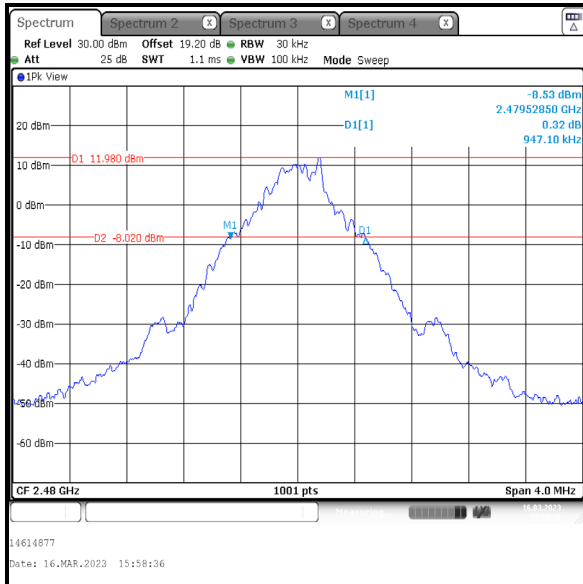

**Top Channel**



**Transmitter 20 dB Bandwidth (continued)**

**Results: 2DH5 / SISO / Core 1**

Channel	20 dB Bandwidth (kHz)
Bottom	1382.600
Middle	1386.600
Top	1386.600

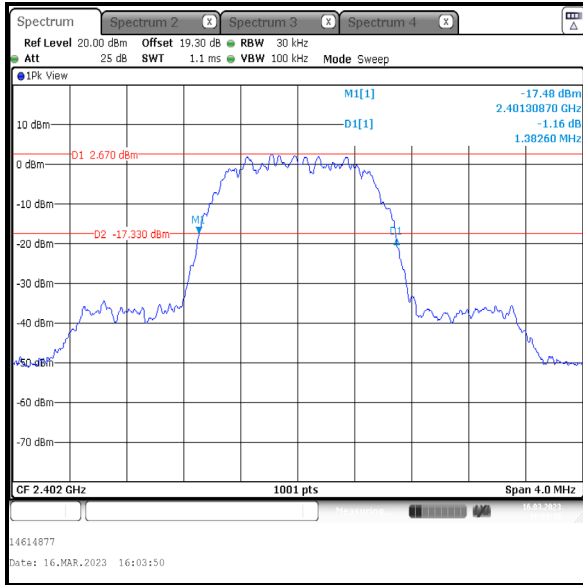

**Bottom Channel**

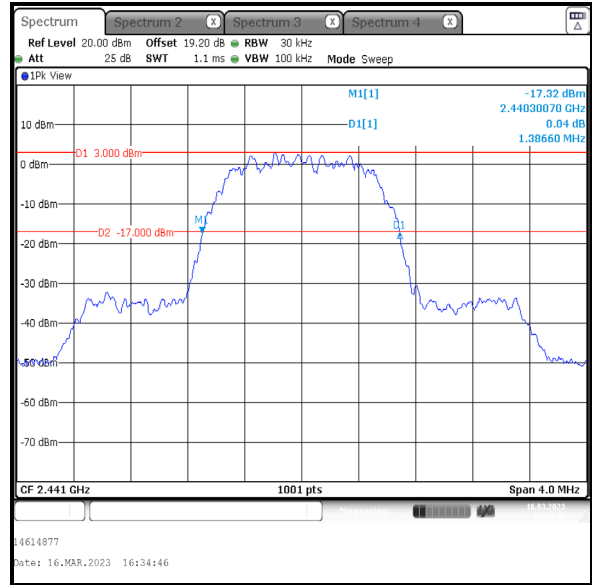

**Middle Channel**

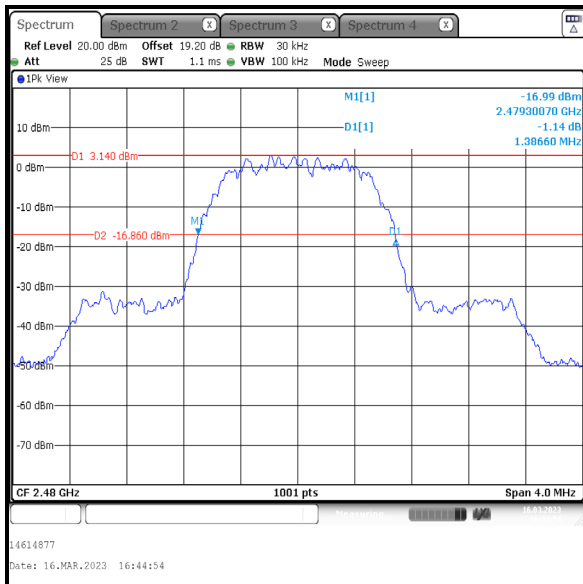

**Top Channel**

**Transmitter 20 dB Bandwidth (continued)**

**Results: 3DH5 / SISO / Core 1**

Channel	20 dB Bandwidth (kHz)
Bottom	1366.600
Middle	1374.600
Top	1370.600

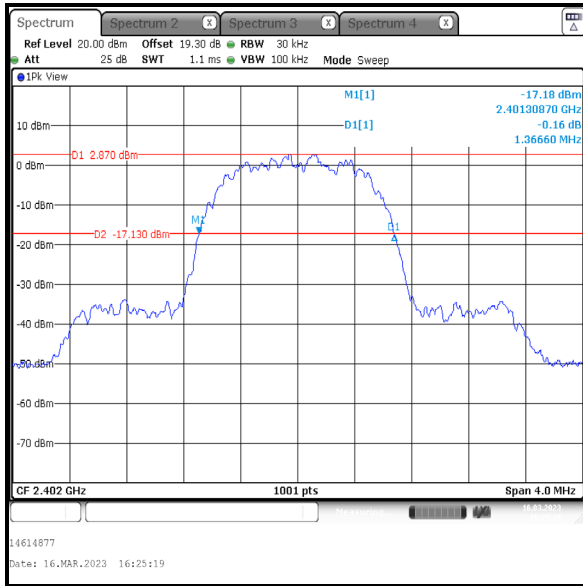

**Bottom Channel**

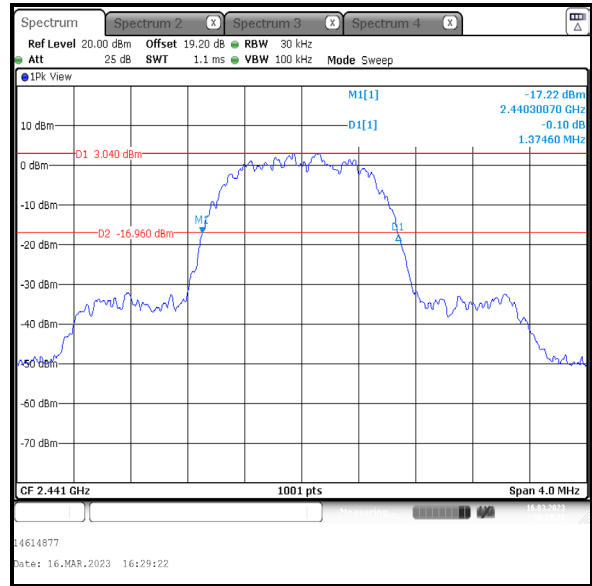

**Middle Channel**

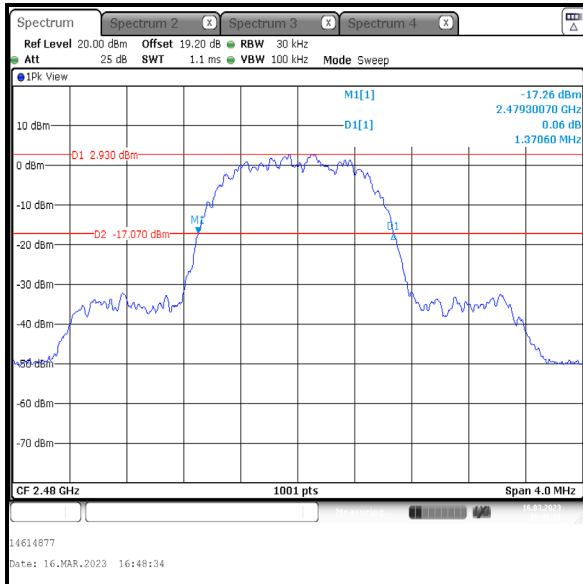

**Top Channel**

**Transmitter 20 dB Bandwidth (continued)**

**Results: DH5 / SISO / Core 2**

Channel	20 dB Bandwidth (kHz)
Bottom	935.100
Middle	935.100
Top	935.100

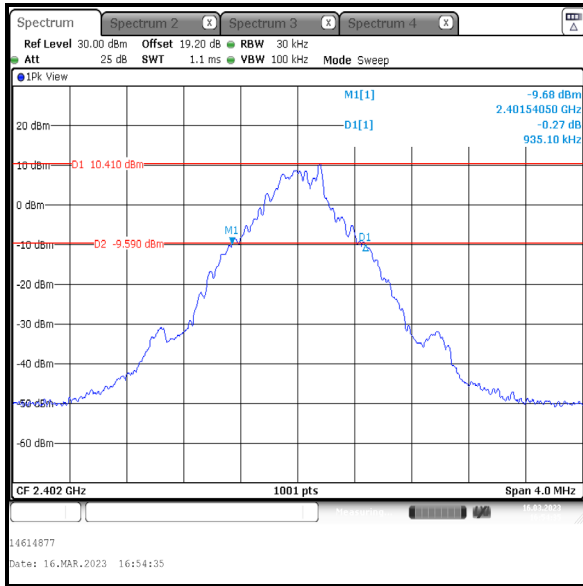

**Bottom Channel**

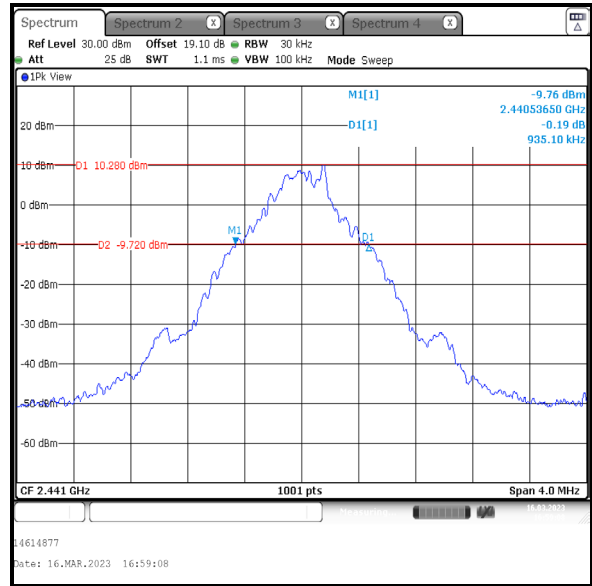

**Middle Channel**

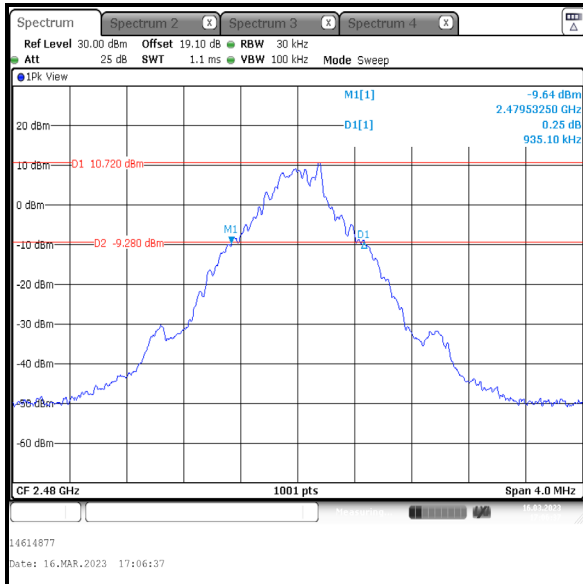

**Top Channel**

**Transmitter 20 dB Bandwidth (continued)**

**Results: 2DH5 / SISO / Core 2**

Channel	20 dB Bandwidth (kHz)
Bottom	1382.600
Middle	1378.600
Top	1378.600

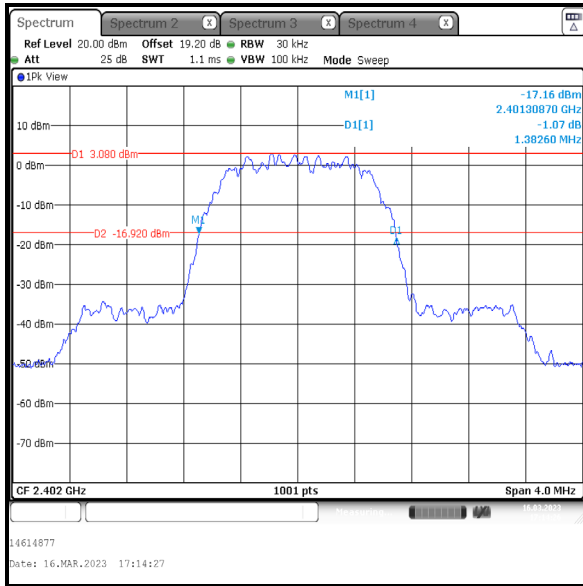

**Bottom Channel**

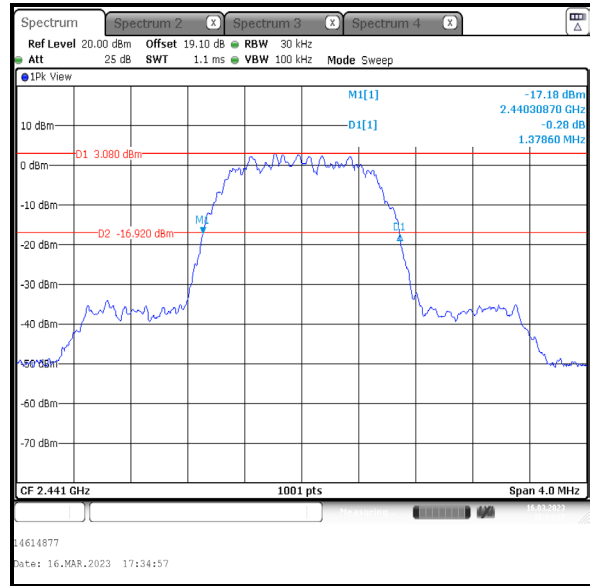

**Middle Channel**

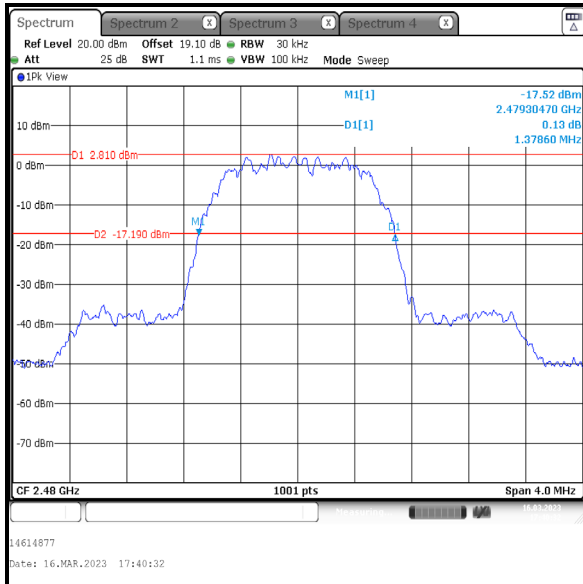

**Top Channel**

**Transmitter 20 dB Bandwidth (continued)**

**Results: 3DH5 / SISO / Core 2**

Channel	20 dB Bandwidth (kHz)
Bottom	1366.600
Middle	1362.600
Top	1362.600

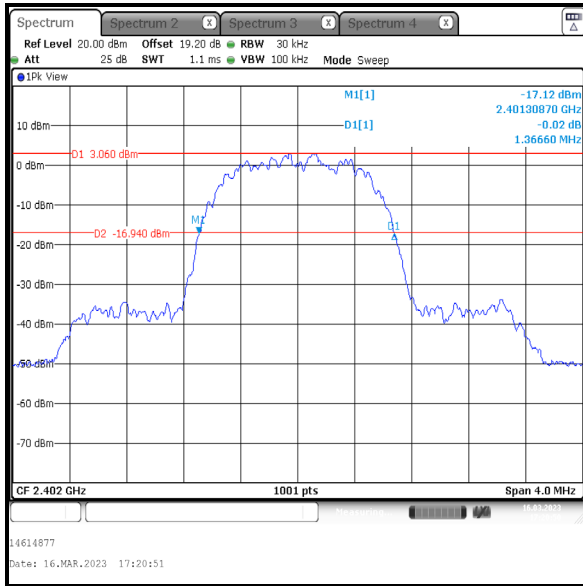

**Bottom Channel**

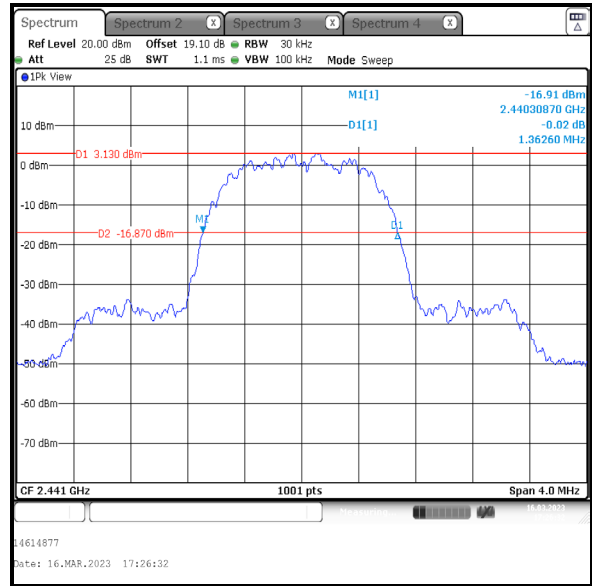

**Middle Channel**

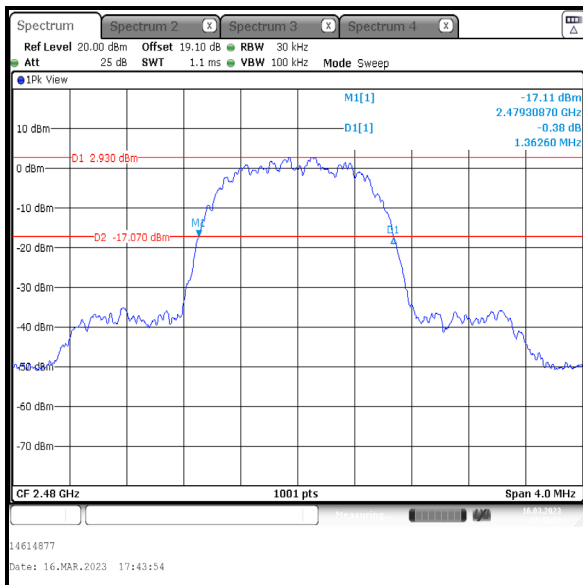

**Top Channel**