

FCC and ISED Test Report

Apple Inc
Model: A2737

In accordance with FCC 47 CFR Part 15C, ISED RSS-247
and ISED RSS-GEN
(2.4 GHz Bluetooth, 2.4 GHz WLAN and 5 GHz WLAN)

Prepared for: Apple Inc
One Apple Park Way
Cupertino, California
95014, USA

FCC ID: BCGA2737

IC: 579C-A2737



Add value.
Inspire trust.

COMMERCIAL-IN-CONFIDENCE

Document 75954422-14 Issue 01

SIGNATURE

NAME	JOB TITLE	RESPONSIBLE FOR	ISSUE DATE
Matthew Russell	Senior Engineer (RF)	Authorised Signatory	23 September 2022

Signatures in this approval box have checked this document in line with the requirements of TÜV SÜD document control rules.

ENGINEERING STATEMENT

The measurements shown in this report were made in accordance with the procedures described on test pages. All reported testing was carried out on a sample equipment to demonstrate limited compliance with FCC 47 CFR Part 15C, ISED RSS-247 and ISED RSS-GEN. The sample tested was found to comply with the requirements defined in the applied rules.

RESPONSIBLE FOR	NAME	DATE	SIGNATURE
Report Generation	Lauren Walters	23 September 2022	

FCC Accreditation

90987 Octagon House, Fareham Test Laboratory

ISED Accreditation

12669A Octagon House, Fareham Test Laboratory

EXECUTIVE SUMMARY

A sample of this product was tested and found to be compliant with FCC 47 CFR Part 15C: 2020, ISED RSS-247: Issue 2 (02-2017) and ISED RSS-GEN: and Issue 5 (04-2018) + A2 (02-2021) for the tests detailed in section 1.3.



DISCLAIMER AND COPYRIGHT

This non-binding report has been prepared by TÜV SÜD with all reasonable skill and care. The document is confidential to the potential Client and TÜV SÜD. No part of this document may be reproduced without the prior written approval of TÜV SÜD. © 2022 TÜV SÜD. This report relates only to the actual item/items tested.

ACCREDITATION

Our UKAS Accreditation does not cover opinions and interpretations and any expressed are outside the scope of our UKAS Accreditation. Results of tests not covered by our UKAS Accreditation Schedule are marked NUA (Not UKAS Accredited).

TÜV SÜD
is a trading name of TÜV SÜD Ltd
Registered in Scotland at East Kilbride,
Glasgow G75 0QF, United Kingdom
Registered number: SC215164

TÜV SÜD Ltd is a
TÜV SÜD Group Company

Phone: +44 (0) 1489 558100
Fax: +44 (0) 1489 558101
www.tuvsud.com/en

TÜV SÜD
Octagon House
Concorde Way
Fareham
Hampshire PO15 5RL
United Kingdom



Contents

1	Report Summary	2
1.1	Report Modification Record.....	2
1.2	Introduction.....	2
1.3	Brief Summary of Results	3
1.4	Product Information	4
1.5	Deviations from the Standard.....	4
1.6	EUT Modification Record	4
1.7	Test Location	5
2	Test Details	6
2.1	Radiated Spurious Emissions (Simultaneous Transmission)	6
3	Measurement Uncertainty	20



1 Report Summary

1.1 Report Modification Record

Alterations and additions to this report will be issued to the holders of each copy in the form of a complete document.

Issue	Description of Change	Date of Issue
1	First Issue	23 September 2022

Table 1

1.2 Introduction

Applicant	Apple Inc
Manufacturer	Apple Inc
Model Number(s)	A2737
Serial Number(s)	QQRXMCWXL5
Hardware Version(s)	REV 1.0
Software Version(s)	20J42560n
Number of Samples Tested	1
Test Specification/Issue/Date	FCC 47 CFR Part 15: 2020 ISED RSS-247: Issue 2 (02-2017) ISED RSS-GEN: Issue 5 (04-2018) + A2 (02-2021)
Order Number	540246998
Date of Receipt of EUT	01-July-2022
Start of Test	10-August-2022
Finish of Test	07-September-2022
Name of Engineer(s)	Ian Hart, Elliot Callender, Thomas Randall, Colin Brain, Mohammad Malik and Faisal Malyar
Related Document(s)	ANSI C63.4 2014 ANSI C63.10: 2013



1.3 Brief Summary of Results

A brief summary of the tests carried out in accordance with FCC 47 CFR Part 15C, ISED RSS-247 and ISED RSS-GEN is shown below.

Section	Specification Clause			Test Description	Result	Comments/Base Standard
	Part 15C	RSS-247	RSS-GEN			
Configuration and Mode: CoTx - 5 GHz WLAN and Bluetooth						
2.1	15.209, 15.247(d) and 15.407(b)	5.5 and 6.2	8.9	Radiated Spurious Emissions (Simultaneous Transmission)	Pass	
Configuration and Mode: SDB - 2.4 GHz WLAN and 5 GHz WLAN						
2.1	15.209, 15.247(d) and 15.407(b)	5.5 and 6.2	8.9	Radiated Spurious Emissions (Simultaneous Transmission)	Pass	

Table 2



1.4 Product Information

1.4.1 Technical Description

The equipment under test was an Apple TV Set Top Box with Bluetooth® and IEEE 802.11 a/b/g/n/ac/ax Wi-Fi capabilities in the 2.4GHz and 5GHz bands.

1.5 Deviations from the Standard

No deviations from the applicable test standard were made during testing.

1.6 EUT Modification Record

The table below details modifications made to the EUT during the test programme.

The modifications incorporated during each test are recorded on the appropriate test pages.

Modification State	Description of Modification still fitted to EUT	Modification Fitted By	Date Modification Fitted
Model: A2737, Serial Number: QQRXMCWXL5			
0	As supplied by the customer	Not Applicable	Not Applicable

Table 3



1.7 Test Location

TÜV SÜD conducted the following tests at our Concorde Park Test Laboratory.

Test Name	Name of Engineer(s)	Accreditation
Configuration and Mode: CoTx - 5 GHz WLAN and Bluetooth		
Radiated Spurious Emissions (Simultaneous Transmission)	Ian Hart, Elliot Callender and Thomas Randall	UKAS
Configuration and Mode: SDB - 2.4 GHz WLAN and 5 GHz WLAN		
Radiated Spurious Emissions (Simultaneous Transmission)	Ian Hart, Elliot Callender, Thomas Randall, Colin Brain, Mohammad Malik and Faisal Malyar	UKAS

Table 4

Office Address:

TÜV SÜD
Concorde Park
Concorde Way
Fareham
Hampshire
PO15 5FG
United Kingdom

TÜV SÜD conducted the following tests at our Octagon House Test Laboratory.

Test Name	Name of Engineer(s)	Accreditation
Configuration and Mode: CoTx - 5 GHz WLAN and Bluetooth		
Radiated Spurious Emissions (Simultaneous Transmission)	Ian Hart, Elliot Callender and Thomas Randall	UKAS
Configuration and Mode: SDB - 2.4 GHz WLAN and 5 GHz WLAN		
Radiated Spurious Emissions (Simultaneous Transmission)	Ian Hart, Elliot Callender, Thomas Randall, Colin Brain, Mohammad Malik and Faisal Malyar	UKAS

Table 5

Office Address:

TÜV SÜD
Octagon House
Concorde Way
Fareham
Hampshire
PO15 5RL
United Kingdom



2 Test Details

2.1 Radiated Spurious Emissions (Simultaneous Transmission)

2.1.1 Specification Reference

FCC 47 CFR Part 15C, Clause 15.209, 15.247(d) and 15.407(b)
ISED RSS-247, Clause 5.5 and 6.2
ISED RSS-GEN, Clause 8.9

2.1.2 Equipment Under Test and Modification State

A2737, S/N: QQRXMCWXL5 - Modification State 0

2.1.3 Date of Test

10-August-2022 to 07-September-2022

2.1.4 Test Method

This test was performed in accordance with ANSI C63.10, clause 6.3, 6.5 and 6.6.

The EUT was placed on the non-conducting platform in a manner typical of a normal installation.

Ports on the EUT were terminated with loads as described in ANSI C63.4 clause 6.2.4 for each type of port on the EUT.

For frequencies > 1 GHz, plots for average measurements were taken in accordance with ANSI C63.10, clause 4.1.4.2.5 to characterize the EUT. Where emissions were detected, final average measurements were taken in accordance with ANSI C63.10, clause 4.1.4.2.2, 11.11, 11.12, 12.7.2 or 12.7.3 depending on the nature of the emission measured.

The plots shown are the characterisation of the EUT. The limits on the plots represent the most stringent case for restricted bands, (74/54 dBuV/m) when compared to non-restricted band limits. The limits shown have been used as a threshold to determine where further measurements are necessary. Where results are within 10 dB of the limits shown on the plots, further investigation was carried out and reported in results tables.

The following conversion can be applied to convert from dB μ V/m to μ V/m:

$10^{(\text{Field Strength in dB}\mu\text{V/m}/20)}$.

At a measurement distance of 1 meter the limit line was increased by $20 \cdot \text{LOG}(3/1) = 9.54$ dB.

2.1.5 Test Setup Diagram

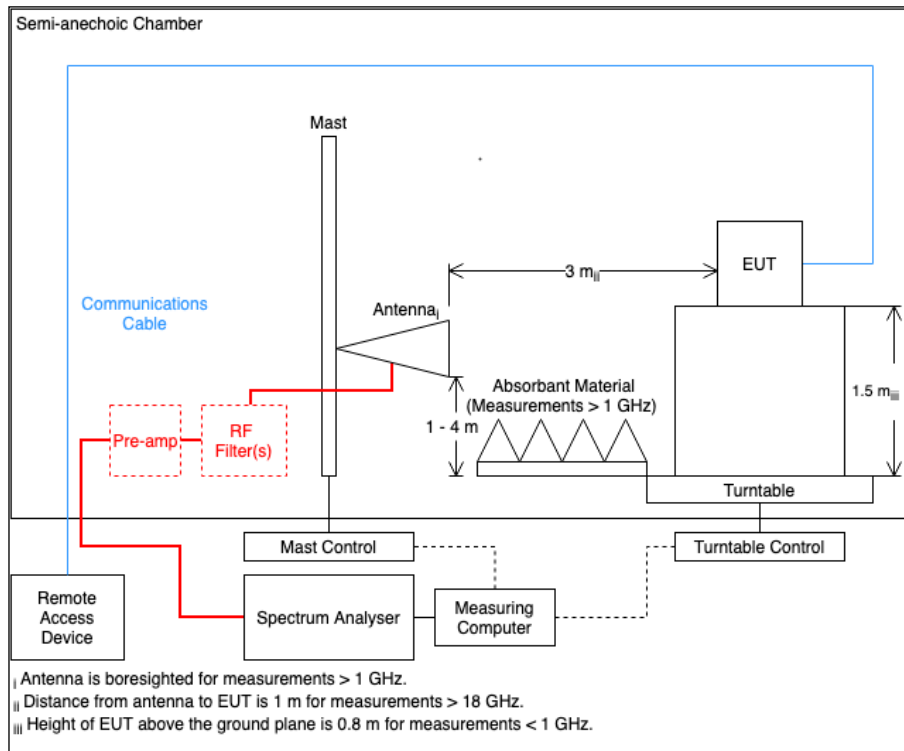

Figure 1

2.1.6 Environmental Conditions

Ambient Temperature	19.3 - 23.3 °C
Relative Humidity	44.5 - 60.9 %



2.1.7 Test Results

CoTx - 2.4 GHz WLAN and 5 GHz WLAN and Bluetooth

Frequency (MHz)	Level (dBuV/m)	Limit (dBuV/m)	Margin (dB)	Detector	Angle (°)	Height (cm)	Polarisation
*							

Table 6 - U-NII-1 – 5200 MHz (CH40), VHT20, CDD, Core 0 + Core 1 and 2402 MHz (CH0), BDR, ePA, Core 0 + Core 1, 30 MHz to 40 GHz

*No emissions found within 10 dB of the limit.

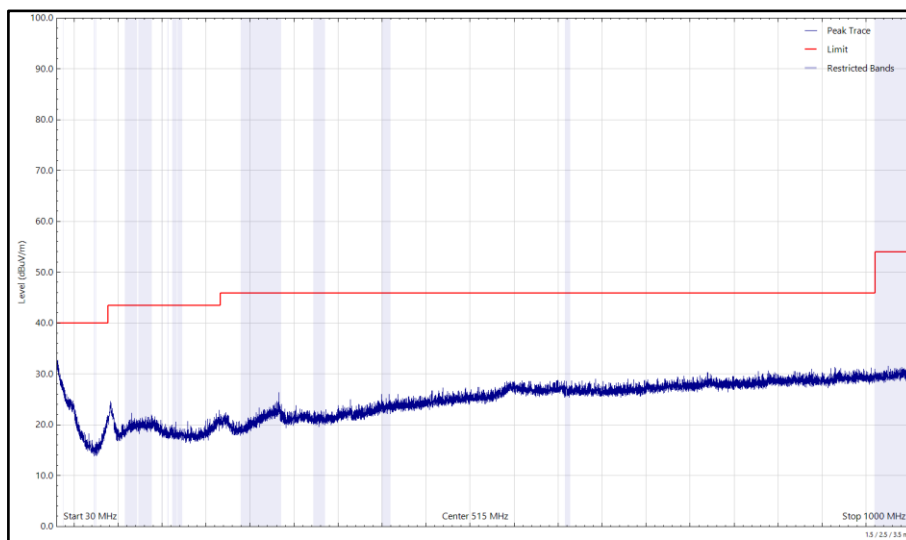

Figure 2 - U-NII-1 – 5200 MHz (CH40), VHT20, CDD, Core 0 + Core 1 and 2402 MHz (CH0), BDR, ePA, Core 0 + Core 1, 30 MHz to 1 GHz, Horizontal (Peak)

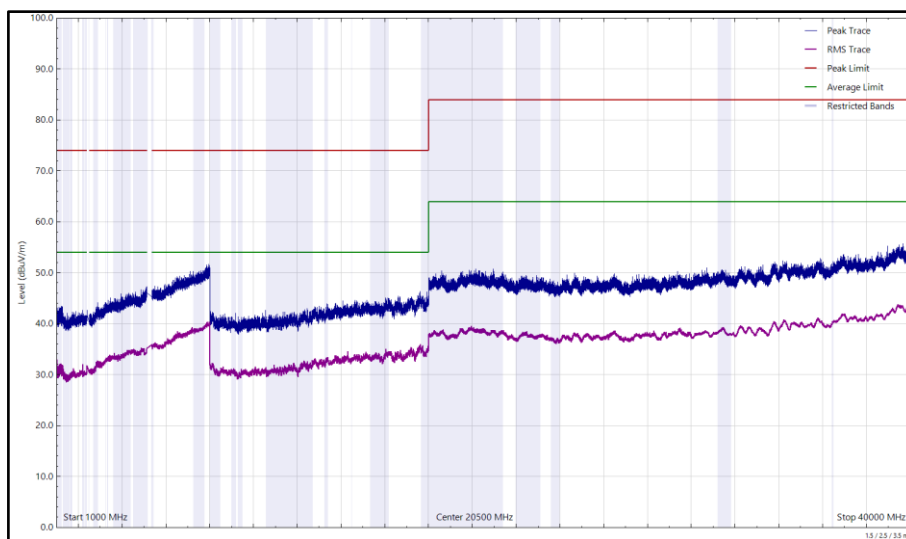

Figure 3 - U-NII-1 – 5200 MHz (CH40), VHT20, CDD, Core 0 + Core 1 and 2402 MHz (CH0), BDR, ePA, Core 0 + Core 1, 1 GHz to 40 GHz, Horizontal

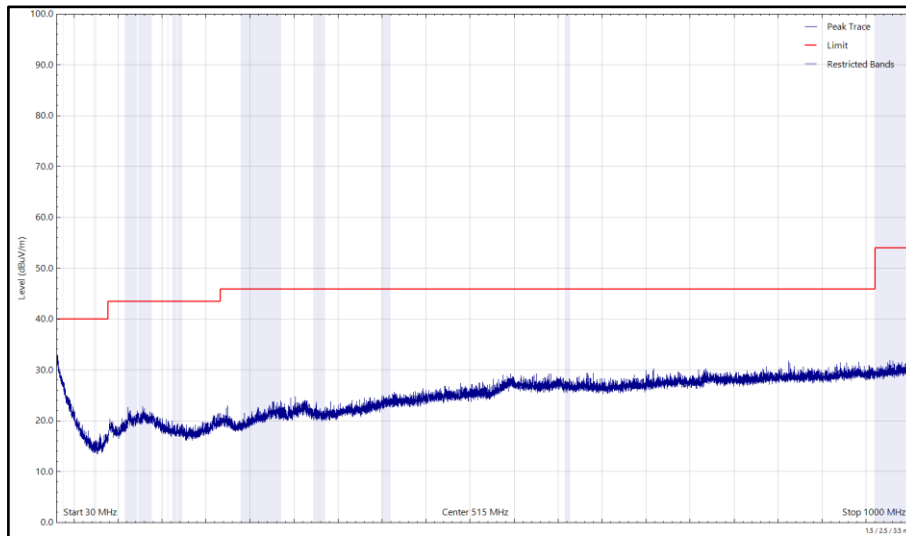

Figure 4 - U-NII-1 – 5200 MHz (CH40), VHT20, CDD, Core 0 + Core 1 and 2402 MHz (CH0), BDR, ePA, Core 0 + Core 1, 30 MHz to 1 GHz, Vertical (Peak)

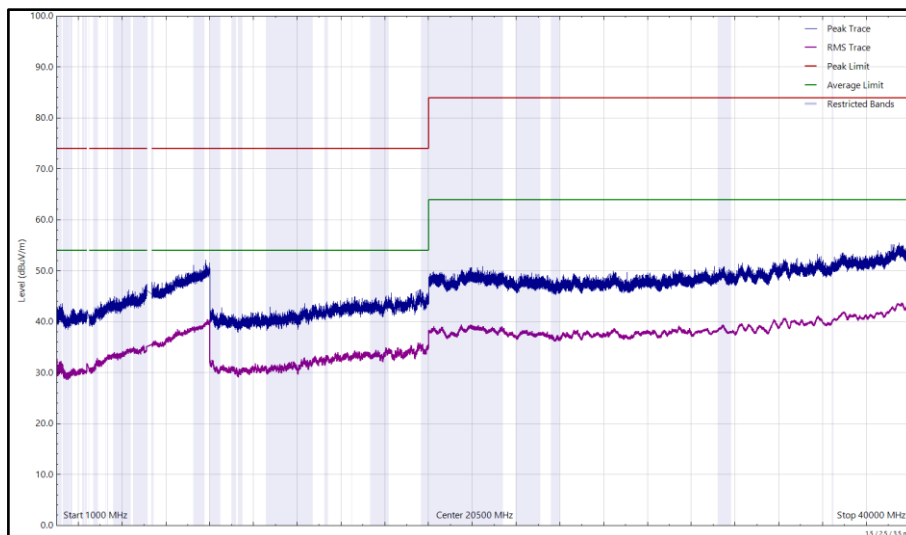

Figure 5 - U-NII-1 – 5200 MHz (CH40), VHT20, CDD, Core 0 + Core 1 and 2402 MHz (CH0), BDR, ePA, Core 0 + Core 1, 1 GHz to 40 GHz, Vertical



Frequency (MHz)	Level (dBuV/m)	Limit (dBuV/m)	Margin (dB)	Detector	Angle (°)	Height (cm)	Polarisation
4960.067	38.1	54.0	-15.9	RMS	11	116	Vertical

Table 7 - U-NII-2C – 5680 MHz (CH136), VHT20, CDD, Core 0 + Core 1 and 2480 MHz (CH78), BDR, ePA, Core 0 + Core 1, 30 MHz to 40 GHz

No other emissions found within 10 dB of the limit.

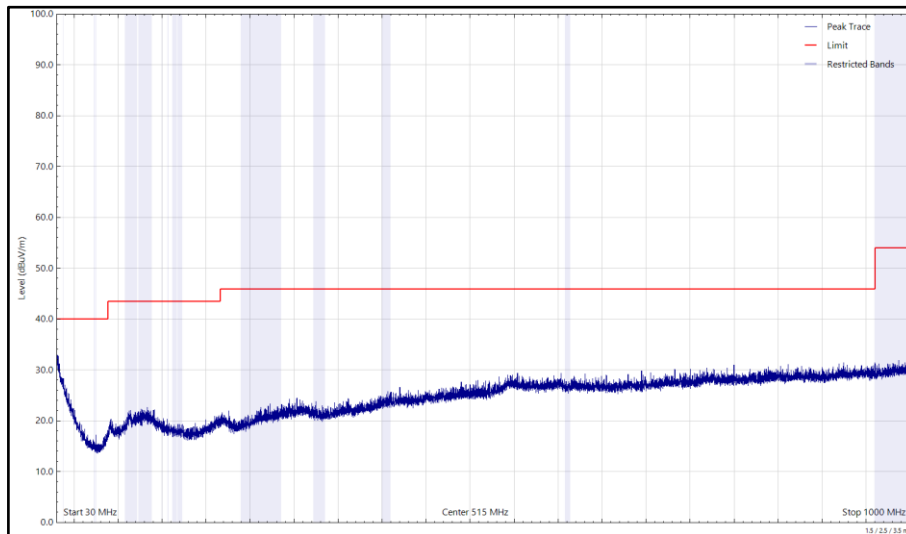

Figure 6 - U-NII-2C – 5680 MHz (CH136), VHT20, CDD, Core 0 + Core 1 and 2480 MHz (CH78), BDR, ePA, Core 0 + Core 1, 30 MHz to 1 GHz, Horizontal (Peak)

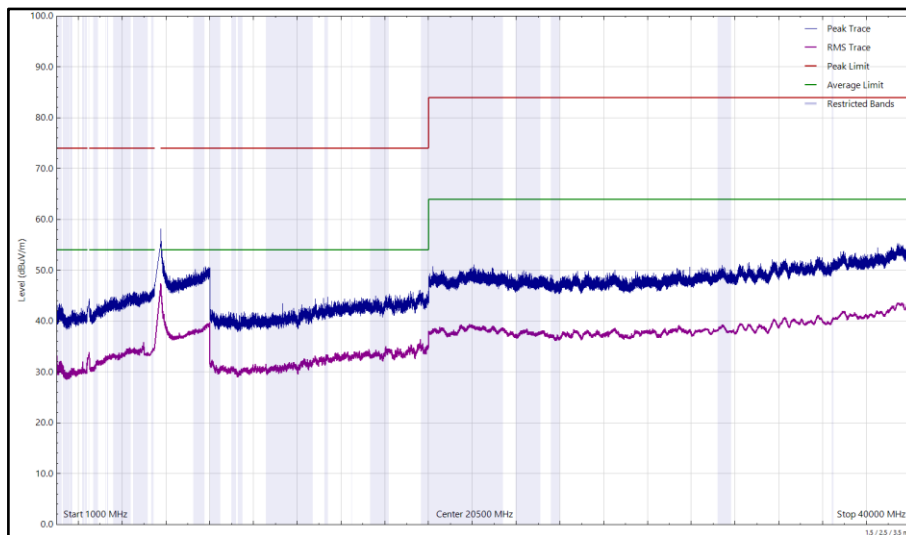

Figure 7 - U-NII-2C – 5680 MHz (CH136), VHT20, CDD, Core 0 + Core 1 and 2480 MHz (CH78), BDR, ePA, Core 0 + Core 1, 1 GHz to 40 GHz, Horizontal

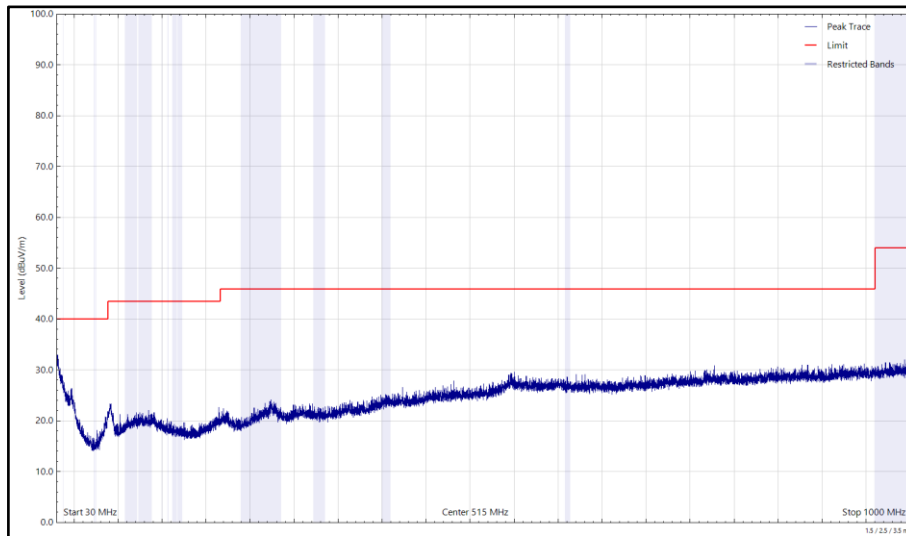

Figure 8 - U-NII-2C – 5680 MHz (CH136), VHT20, CDD, Core 0 + Core 1 and 2480 MHz (CH78), BDR, ePA, Core 0 + Core 1, 30 MHz to 1 GHz, Vertical (Peak)

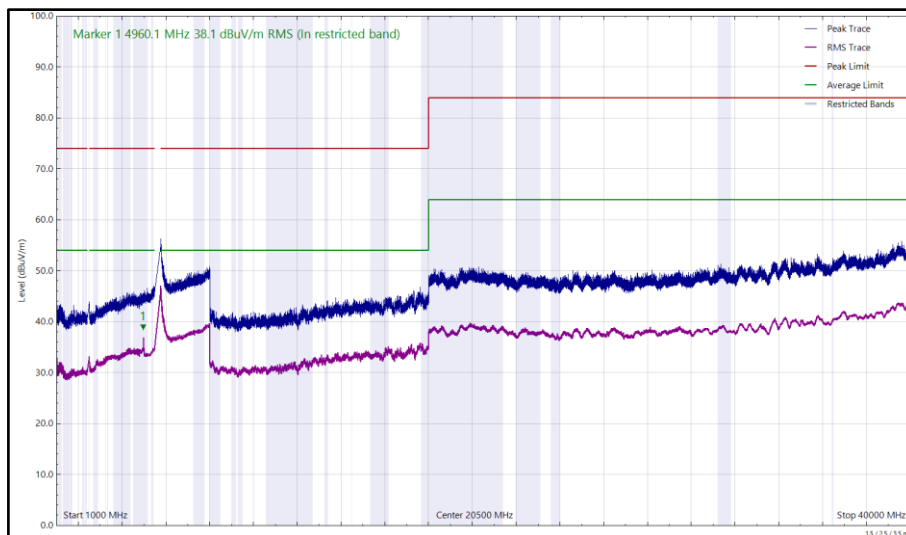

Figure 9 - U-NII-2C – 5680 MHz (CH136), VHT20, CDD, Core 0 + Core 1 and 2480 MHz (CH78), BDR, ePA, Core 0 + Core 1, 1 GHz to 40 GHz, Vertical



FCC 47 CFR Part 15, ISED RSS-247 and ISED RSS-GEN

The least stringent limit from the applicable rule parts was used to determine compliance for Radiated Emissions testing of multiple transmission sources.

The least stringent applicable limit was:

Clause	Limit
Part 15.247 (d) / RSS-247 Clause 5.5	-20 dBc
Part 15.209 / RSS-GEN Clause 6.13	Peak: 74 dB μ V/m at 3m, Average 54 dB μ V/m at 3m

Table 8



SDB - 2.4 GHz WLAN and 5 GHz WLAN

Frequency (MHz)	Level (dBuV/m)	Limit (dBuV/m)	Margin (dB)	Detector	Angle (°)	Height (cm)	Polarisation
4823.650	37.0	54.0	-17.0	RMS	10	141	Vertical
4823.813	35.8	54.0	-18.3	RMS	314	187	Horizontal

Table 9 - 2412 MHz (CH1), HT20, Core 0 + Core 1 and U-NII-1 - 5200 MHz (CH40), VHT20, CDD, Core 0 + Core 1, 30 MHz to 40 GHz

No other emissions found within 10 dB of the limit.

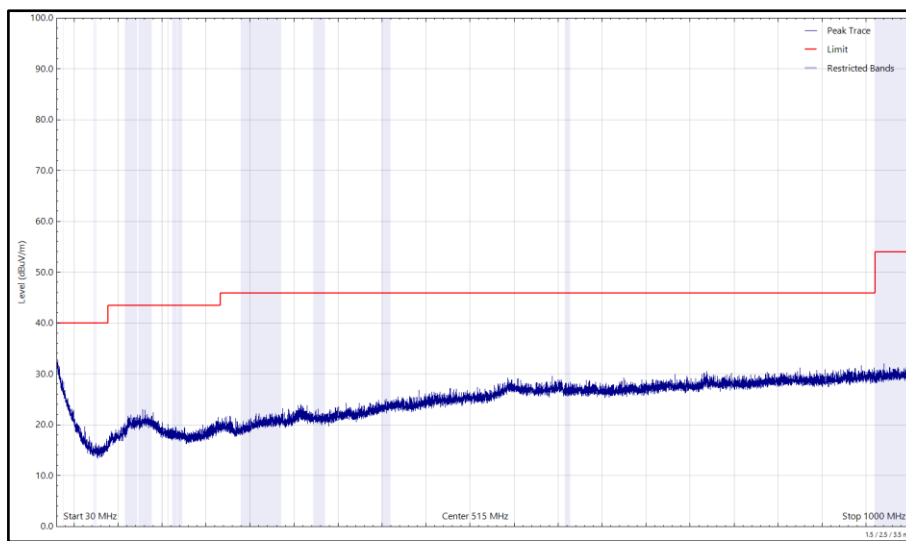

Figure 10 - 2412 MHz (CH1), HT20, Core 0 + Core 1 and U-NII-1 - 5200 MHz (CH40), VHT20, CDD, Core 0 + Core 1, 30 MHz to 1 GHz, Horizontal (Peak)

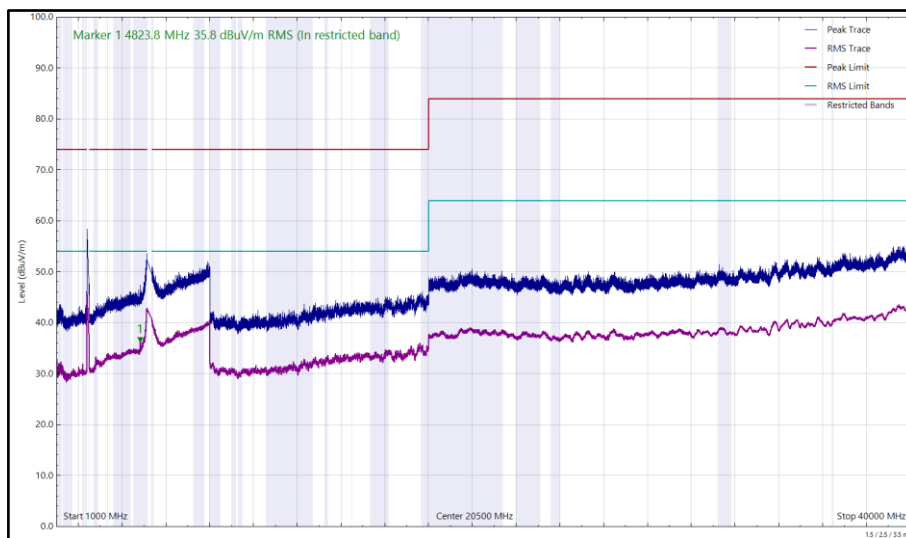

Figure 11 - 2412 MHz (CH1), HT20, Core 0 + Core 1 and U-NII-1 - 5200 MHz (CH40), VHT20, CDD, Core 0 + Core 1, 1 GHz to 40 GHz, Horizontal

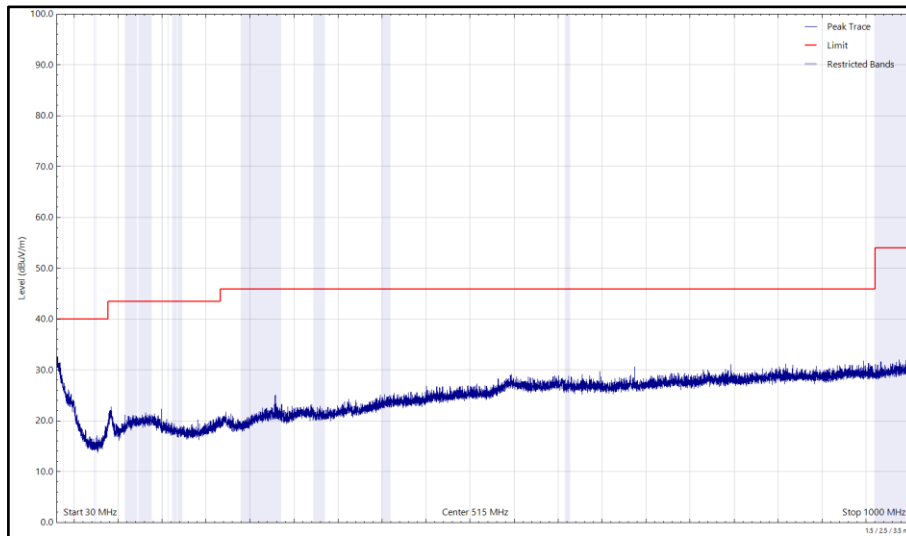

Figure 12 - 2412 MHz (CH1), HT20, Core 0 + Core 1 and U-NII-1 - 5200 MHz (CH40), VHT20, CDD, Core 0 + Core 1, 30 MHz to 1 GHz, Vertical (Peak)

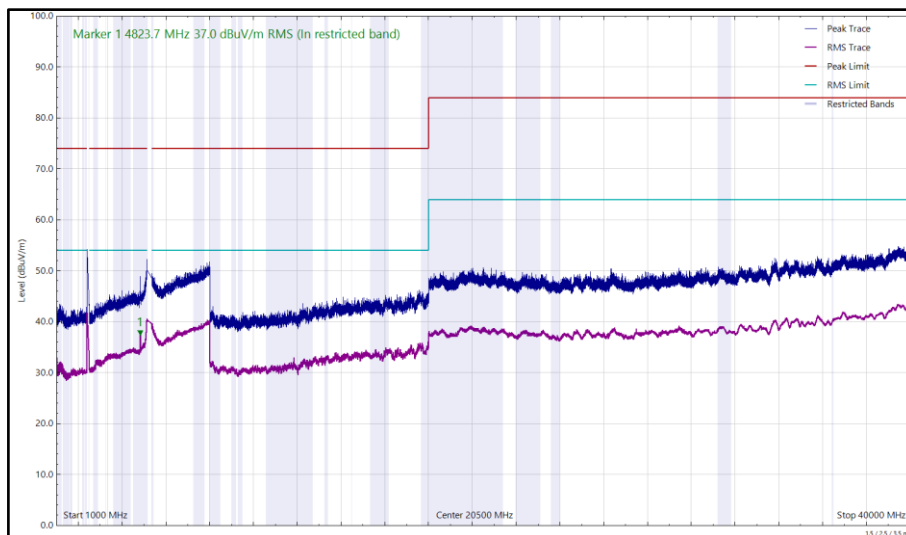

Figure 13 - 2412 MHz (CH1), HT20, Core 0 + Core 1 and U-NII-1 - 5200 MHz (CH40), VHT20, CDD, Core 0 + Core 1, 1 GHz to 40 GHz, Vertical



Frequency (MHz)	Level (dBuV/m)	Limit (dBuV/m)	Margin (dB)	Detector	Angle (°)	Height (cm)	Polarisation
*							

Table 10 - 2472 MHz (CH13), HT20, Core 0 + Core 1 and U-NII-2C - 5680 MHz (CH136), VHT20, CDD, Core 0 + Core 1, 30 MHz to 40 GHz

*No emissions found within 10 dB of the limit.

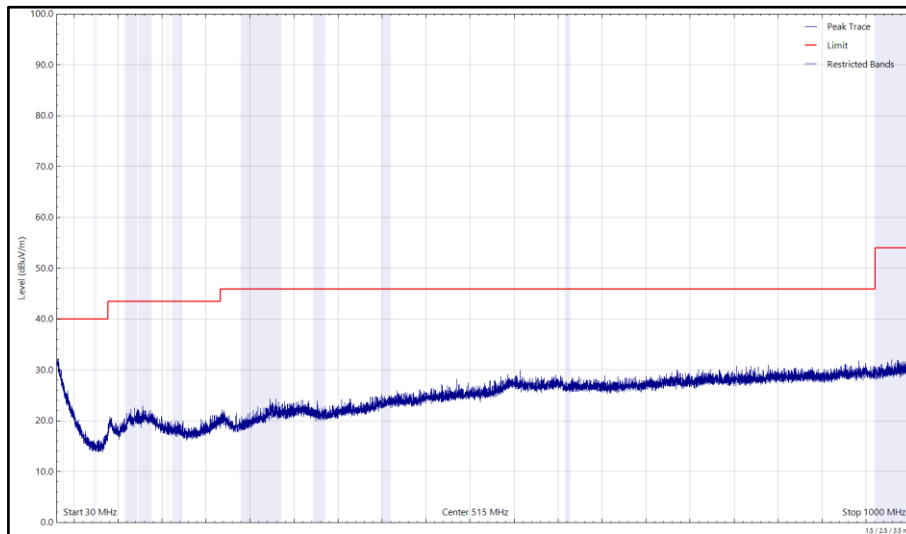

Figure 14 - 2472 MHz (CH13), HT20, Core 0 + Core 1 and U-NII-2C - 5680 MHz (CH136), VHT20, CDD, Core 0 + Core 1, 30 MHz to 1 GHz, Horizontal (Peak)

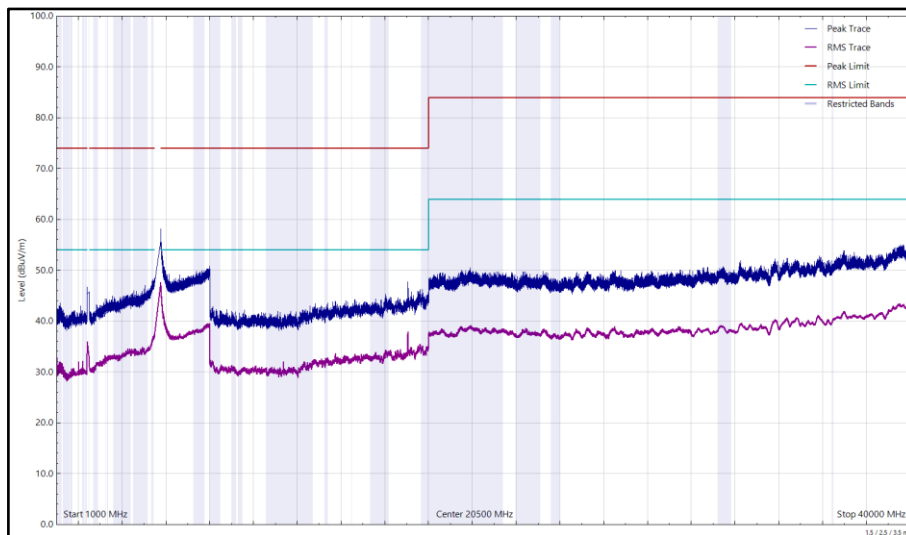

Figure 15 - 2472 MHz (CH13), HT20, Core 0 + Core 1 and U-NII-2C - 5680 MHz (CH136), VHT20, CDD, Core 0 + Core 1, 1 GHz to 40 GHz, Horizontal

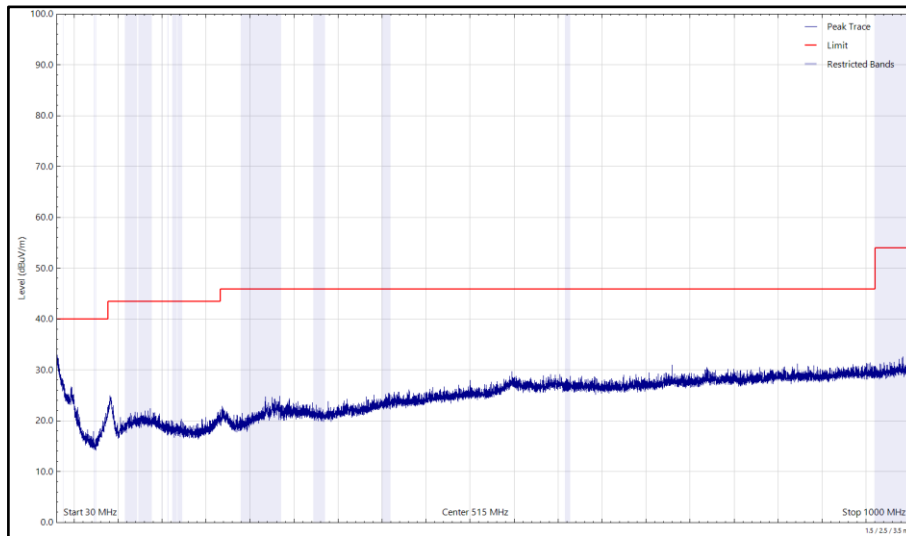

Figure 16 - 2472 MHz (CH13), HT20, Core 0 + Core 1 and U-NII-2C - 5680 MHz (CH136), VHT20, CDD, Core 0 + Core 1, 30 MHz to 1 GHz, Vertical (Peak)

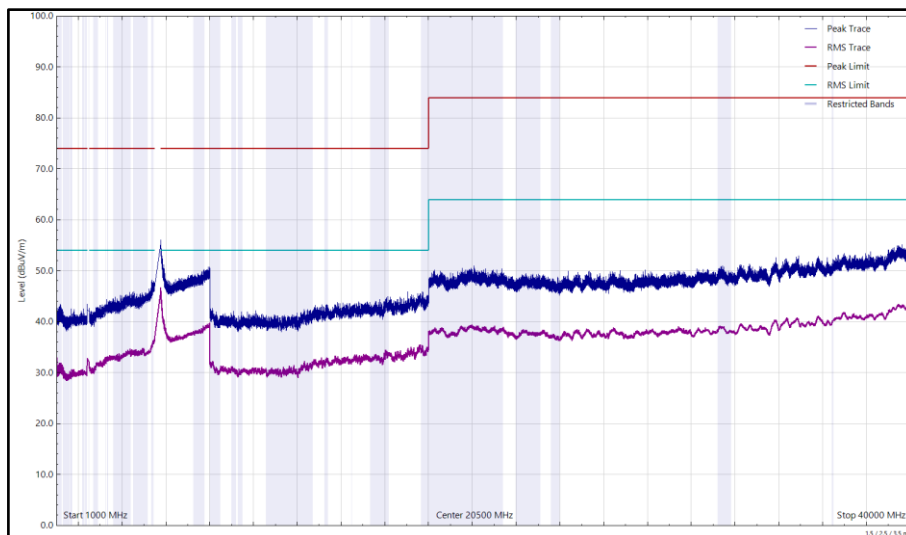

Figure 17 - 2472 MHz (CH13), HT20, Core 0 + Core 1 and U-NII-2C - 5680 MHz (CH136), VHT20, CDD, Core 0 + Core 1, 1 GHz to 40 GHz, Vertical



FCC 47 CFR Part 15, ISED RSS-247 and ISED RSS-GEN

The least stringent limit from the applicable rule parts was used to determine compliance for Radiated Emissions testing of multiple transmission sources.

The least stringent applicable limit was:

Clause	Limit
Part 15.247 (d) / RSS-247 Clause 5.5	-30 dBc
Part 15.209 / RSS-GEN Clause 6.13	Peak: 74 dBµV/m at 3m, Average 54 dBµV/m at 3m

Table 11

2.1.8 Test Location and Test Equipment Used

This test was carried out in RF Chamber 11, RF Chamber 14, and RF Chamber 15.

Instrument	Manufacturer	Type No	TE No	Calibration Period (months)	Calibration Expires
Antenna with attenuator (Bilog, 30 MHz to 3 GHz)	Schaffner	CBL6143	287	24	14-Oct-2022
Band Reject Filter - 2.425 GHz	Wainwright	WRCGV14-2390-2400-2450-2460-50SS	5067	12	29-Sep-2022
Band Reject Filter - 2.4585 GHz	Wainwright	WRCGV14-2423.5-2433.5-2483.5-2493.5-50SS	5069	12	11-Oct-2022
Band Reject Filter - 5.22 GHz	Wainwright	WRCJV12-5120-5150-5290-5320-50SS	5073	12	29-Sep-2022
Band Reject Filter - 5.690 GHz	Wainwright	WRCJV8-5635-5670-5710-5745-50SS	5081	12	29-Sep-2022
Screened Room (11)	Rainford	Rainford	5136	36	24-Nov-2024
2m SMA Cable	Junkosha	MWX221-02000AMSAMS/A	5518	12	12-Apr-2023
8m N Type Cable	Junkosha	MWX221-08000NMSNMS/B	5522	12	24-Mar-2023
3 GHz High pass Filter	Wainwright	WHKX12-2580-3000-18000-80SS	5548	12	11-May-2023
1200 MHz Low Pass Filter (02)	Mini-Circuits	1200 MHz Low Pass Filter (02)	5560	12	23-May-2023
EMI Test Receiver	Rohde & Schwarz	ESW44	5911	12	24-Feb-2023
EMI Test Receiver	Rohde & Schwarz	ESW44	5912	12	17-Feb-2023
Cable (K Type 2m)	Junkosha	MWX241-01000KMSKMS/B	5934	12	14-May-2023
Cable (K Type 2m)	Junkosha	MWX241-01000KMSKMS/B	5937	12	14-May-2023



Instrument	Manufacturer	Type No	TE No	Calibration Period (months)	Calibration Expires
DRG Horn Antenna (7.5-18GHz)	Schwarzbeck	HWRD750	5939	12	29-May-2023
DRG Horn Antenna (7.5-18GHz)	Schwarzbeck	HWRD750	5941	12	29-May-2023
TRILOG Super Broadband Test Antenna	Schwarzbeck	VULB 9168	5943	24	03-Feb-2024
TRILOG Super Broadband Test Antenna	Schwarzbeck	VULB 9168	5944	24	03-Feb-2024
5m Semi-Anechoic Chamber (Dual-Axis)	Albatross Projects	RF Chamber 14	5958	36	24-Apr-2025
Compact Antenna Mast	Maturo Gmbh	CAM4.0-P	5959	-	TU
Mast & Turntable Controller	Maturo Gmbh	FCU3.0	5960	-	TU
Tilt Antenna Mast	Maturo Gmbh	BAM4.5-P	5961	-	TU
Turntable	Maturo Gmbh	TT1.5SI	5962	-	TU
5m Semi-Anechoic Chamber (Dual-Axis)	Albatross Projects	RF Chamber 15	5963	36	28-Apr-2025
Compact Antenna Mast	Maturo Gmbh	CAM4.0-P	5964	-	TU
Antenna Mast	Maturo Gmbh	BAM4.5-P	5967	-	TU
Turntable	Maturo Gmbh	TT1.5SI	5968	-	TU
Cable (SMA 1m)	Junkosha	MWX221-01000AMSAMS/A	5996	12	06-Jun-2023
Cable (sma to sma 1m)	Junkosha	MWX221-01000AMSAMS/A	5997	12	06-Jun-2023
Cable (N to N 1m)	Junkosha	MWX221-01000NMSNMS/B	5999	12	05-Jun-2023
Cable (SMA to SMA 4.5m)	Junkosha	MWX221-04500AMSAMS/A	6002	12	06-Jun-2023
Cable (SMA to SMA 6.5m)	Junkosha	MWX221-06500AMSAMS/B	6003	12	07-Jun-2023
Cable (N to N 7m)	Junkosha	MWX221-07000NMSNMS/B	6005	12	05-Jun-2023
Cable (N to N 8m)	Junkosha	MWX221-08000NMSNMS/A	6006	12	05-Jun-2023
Cable (SMA to SMA 1m)	Junkosha	MWX221-01000AMSAMS/A	6007	12	06-Jun-2023
Cable (SMA to SMA 1m)	Junkosha	MWX221-01000AMSAMS/A	6008	12	06-Jun-2023
Cable (N to N 1m)	Junkosha	MWX221-01000AMSAMS/B	6009	12	07-Jun-2023
Cable (SMA to SMA 6.5m)	Junkosha	MWX221-06500AMSAMS/B	6014	12	07-Jun-2023
Cable (N to N 8m)	Junkosha	MWX221-08000NMSNMS/A	6017	12	05-Jun-2023
Horn Antenna (1-10 GHz)	Schwarzbeck	BBHA9120B	6140	12	21-Jun-2023



Instrument	Manufacturer	Type No	TE No	Calibration Period (months)	Calibration Expires
Horn Antenna (1-10 GHz)	Schwarzbeck	BBHA9120B	6141	12	21-Jun-2023
SAC Switch Unit	TUV SUD	SSU001	6144	12	07-Jul-2023
Digital Multimeter	Fluke	115	6146	12	16-Jun-2023
Humidity & Temperature meter	R.S Components	1364	6150	12	17-Jun-2023
Double Ridge Active Horn Antenna (18-40 GHz)	Com-Power	AHA-840	6187	24	02-Jun-2024
Double Ridge Active Horn Antenna (18-40 GHz)	Com-Power	AHA-840	6188	24	02-Jun-2024
8GHz Highpass Filter	Wainwright	WHKX 7150 8000 18000 50SS	6195	12	15-Jul-2023
SAC Switch Unit	TUV SUD	SSU003	6191	12	15-Jul-2023
Pre Amp 8 - 18 GHz	Wright Technologies	APS06 0061	6198	12	19-Jul-2023
Pre Amp 8 - 18 GHz	Wright Technologies	APS06 0061	6199	12	19-Jul-2023
Attenuator 4dB	Pasternack	PE7074-4	6202	24	16-Jul-2024
Attenuator 4dB	Pasternack	PE7074-4	6203	24	16-Jul-2024
Cable (SMA to SMA 20cm)	TUV SUD	MH-FH 8-18	6214	12	25-Jul-2023
Cable (SMA to SMA 20cm)	TUV SUD	MH-FH 8-18	6215	12	25-Jul-2023

Table 12

TU - Traceability Unscheduled



3 Measurement Uncertainty

For a 95% confidence level, the measurement uncertainties for defined systems are:

Test Name	Measurement Uncertainty
Radiated Spurious Emissions (Simultaneous Transmission)	30 MHz to 1 GHz: ± 5.2 dB 1 GHz to 40 GHz: ± 6.3 dB

Table 13

Measurement Uncertainty Decision Rule – Accuracy Method

Determination of conformity with the specification limits is based on the decision rule according to IEC Guide 115:2007, Clause 4.4.3 and 4.5.1. (Procedure 2). The measurement results are directly compared with the test limit to determine conformance with the requirements of the standard.

Risk: The uncertainty of measurement about the measured result is negligible with regard to the final pass/fail decision. The measurement result can be directly compared with the test limit to determine conformance with the requirement (compare IEC Guide 115). The level of risk to falsely accept and falsely reject items is further described in ILAC-G8.