

# FCC and ISED Test Report

Apple Inc  
Model: A2348

In accordance with FCC 47 CFR Part 15,  
ISED RSS-247 and ISED RSS-GEN (2.4 GHz  
WLAN, 5 GHz WLAN and 2.4 GHz Bluetooth)

Prepared for: Apple Inc  
One Apple Park Way  
Cupertino  
California  
95014  
USA



Add value.  
Inspire trust.

FCC ID: BGCA2348

IC: 579C-A2348

## COMMERCIAL-IN-CONFIDENCE

Document 75949235-14 Issue 01

### SIGNATURE

NAME	JOB TITLE	RESPONSIBLE FOR	ISSUE DATE
Steve Marshall	Senior Engineer	Authorised Signatory	09 October 2020

Signatures in this approval box have checked this document in line with the requirements of TÜV SÜD document control rules.

### ENGINEERING STATEMENT

The measurements shown in this report were made in accordance with the procedures described on test pages. All reported testing was carried out on a sample equipment to demonstrate limited compliance with FCC 47 CFR Parts 15, ISED RSS-247 and ISED RSS-GEN. The sample tested was found to comply with the requirements defined in the applied rules.

RESPONSIBLE FOR	NAME	DATE	SIGNATURE
Testing	Aasim Butt	09 October 2020	
Testing	Connor Lee	09 October 2020	
Testing	Colin Brain	09 October 2020	
Testing	Graeme Lawler	09 October 2020	
Testing	Mohammad Malik	09 October 2020	

FCC Accreditation  
90987 Octagon House, Fareham Test Laboratory

ISED Accreditation  
12669A Octagon House, Fareham Test Laboratory

### EXECUTIVE SUMMARY

A sample of this product was tested and found to be compliant with FCC 47 CFR Parts 15: 2019, ISED RSS-247: Issue 2 (2017-02) and ISED RSS-GEN: Issue 5 (04-2018) + A1 (03-2019) for the tests detailed in section 1.3.



#### DISCLAIMER AND COPYRIGHT

This non-binding report has been prepared by TÜV SÜD with all reasonable skill and care. The document is confidential to the potential Client and TÜV SÜD. No part of this document may be reproduced without the prior written approval of TÜV SÜD. © 2020 TÜV SÜD. This report relates only to the actual item/items tested.

#### ACCREDITATION

Our UKAS Accreditation does not cover opinions and interpretations and any expressed are outside the scope of our UKAS Accreditation. Results of tests not covered by our UKAS Accreditation Schedule are marked NUA (Not UKAS Accredited).

TÜV SÜD  
is a trading name of TÜV SÜD Ltd  
Registered in Scotland at East Kilbride,  
Glasgow G75 0QF, United Kingdom  
Registered number: SC215164

TÜV SÜD Ltd is a  
TÜV SÜD Group Company

Phone: +44 (0) 1489 558100  
Fax: +44 (0) 1489 558101  
[www.tuv-sud.co.uk](http://www.tuv-sud.co.uk)

TÜV SÜD  
Octagon House  
Concorde Way  
Fareham  
Hampshire PO15 5RL  
United Kingdom



## Contents

<b>1</b>	<b>Report Summary .....</b>	<b>2</b>
1.1	Report Modification Record.....	2
1.2	Introduction.....	2
1.3	Brief Summary of Results .....	3
1.4	Product Information .....	4
1.5	Deviations from the Standard.....	4
1.6	EUT Modification Record .....	4
1.7	Test Location .....	4
<b>2</b>	<b>Test Details .....</b>	<b>5</b>
2.1	Radiated Spurious Emissions (Simultaneous Transmission) .....	5
<b>3</b>	<b>Measurement Uncertainty .....</b>	<b>28</b>



# 1 Report Summary

## 1.1 Report Modification Record

Alterations and additions to this report will be issued to the holders of each copy in the form of a complete document.

Issue	Description of Change	Date of Issue
1	First Issue	09-October-2020

**Table 1**

## 1.2 Introduction

Applicant	Apple Inc
Manufacturer	Apple Inc
Model Number(s)	A2348
Serial Number(s)	C07CX00W02H6
Hardware Version(s)	REV1.0
Software Version(s)	20W102770t
Number of Samples Tested	1
Test Specification/Issue/Date	FCC 47 CFR Part 15: 2019 ISED RSS-247: Issue 2 (2017-02) ISED RSS-GEN: Issue 5 (04-2018) + A1 (03-2019)
Order Number	0540205400
Date	07-April-2020
Date of Receipt of EUT	18-August-2020
Start of Test	26-August-2020
Finish of Test	09-September-2020
Name of Engineer(s)	Aasim Butt, Connor Lee, Colin Brain, Graeme Lawler and Mohammad Malik
Related Document(s)	ANSI C63.10: 2013



### 1.3 Brief Summary of Results

A brief summary of the tests carried out in accordance with FCC 47 CFR Parts 15, ISED RSS-247 and ISED RSS-GEN is shown below.

Section	Specification Clause			Test Description	Result	Comments/Base Standard
	FCC Part 15	RSS-247	RSS-GEN			
Configuration and Mode: CoTX - 5 GHz WLAN, 2.4 GHz WLAN and 2.4 GHz Bluetooth						
2.1	15.247 (d), 15.407 (b) and 15.209	5.5 and 6.2	8.9 and 8.10	Radiated Spurious Emissions (Simultaneous Transmission)	Pass	ANSI C63.10: 2013
Configuration and Mode: SDB - 2.4 GHz WLAN and 5 GHz WLAN						
2.1	15.247 (d), 15.407 (b) and 15.209	5.5 and 6.2	8.9 and 8.10	Radiated Spurious Emissions (Simultaneous Transmission)	Pass	ANSI C63.10: 2013

**Table 2**



## 1.4 Product Information

### 1.4.1 Technical Description

The Equipment Under Test (EUT) was a Desktop PC with Bluetooth, Bluetooth Low Energy and 802.11 a/b/g/n/ac/ax capabilities in the 2.4 GHz and 5 GHz bands.

### 1.5 Deviations from the Standard

No deviations from the applicable test standard were made during testing.

### 1.6 EUT Modification Record

The table below details modifications made to the EUT during the test programme.

The modifications incorporated during each test are recorded on the appropriate test pages.

Modification State	Description of Modification still fitted to EUT	Modification Fitted By	Date Modification Fitted
Model: A2348, Serial Number: C07CX00W02H6			
0	As supplied by the customer	Not Applicable	Not Applicable

**Table 3**

### 1.7 Test Location

TÜV SÜD conducted the following tests at our Fareham Test Laboratory.

Test Name	Name of Engineer(s)	Accreditation
Configuration and Mode: CoTX - 5 GHz WLAN, 2.4 GHz WLAN and 2.4 GHz Bluetooth		
Radiated Spurious Emissions (Simultaneous Transmission)	Aasim Butt, Connor Lee, Colin Brain, Graeme Lawler and Mohammad Malik	UKAS
Configuration and Mode: SDB - 2.4 GHz WLAN and 5 GHz WLAN		
Radiated Spurious Emissions (Simultaneous Transmission)	Aasim Butt, Connor Lee, Colin Brain, Graeme Lawler and Mohammad Malik	UKAS

**Table 4**

Office Address:

Octagon House  
Concorde Way  
Segensworth North  
Fareham  
Hampshire  
PO15 5RL  
United Kingdom



## 2 Test Details

### 2.1 Radiated Spurious Emissions (Simultaneous Transmission)

#### 2.1.1 Specification Reference

FCC 47 CFR Parts 15, Clause 15.247 (d), 15.407 (b) and 15.209  
ISED RSS 247, Clause 5.5 and 6.2  
ISED RSS GEN, Clause 8.9 and 8.10

#### 2.1.2 Equipment Under Test and Modification State

A2348, S/N: C07CX00W02H6 - Modification State 0

#### 2.1.3 Date of Test

26-August-2020 to 09-September-2020

#### 2.1.4 Test Method

This test was performed in accordance with ANSI C63.10, clause 6.3, 6.4 and 6.6.

The EUT was placed on the non-conducting platform in a manner typical of a normal installation.

Ports on the EUT were terminated with loads as described in ANSI C63.4 clause 6.2.4 for each type of port on the EUT.

For frequencies > 1 GHz, plots for average measurements were taken in accordance with ANSI C63.10, clause 4.1.4.2.5 to characterize the EUT. Where emissions were detected, final average measurements were taken in accordance with ANSI C63.10, clause 4.1.4.2.2, 11.11, 11.12, 12.7.2 or 12.7.3 depending on the nature of the emission measured.

The plots shown are the characterisation of the EUT. The limits on the plots represent the most stringent case for restricted bands, (74/54 dBuV/m) when compared to non-restricted band limits. The limits shown have been used as a threshold to determine where further measurements are necessary. Where results are within 10 dB of the limits shown on the plots, further investigation was carried out and reported in results tables.

The following conversion can be applied to convert from dB $\mu$ V/m to  $\mu$ V/m:  
 $10^{(\text{Field Strength in dB}\mu\text{V/m}/20)}$ .

To determine the emission characteristic of the EUT above 18 GHz, the test antenna was swept over all faces of the EUT whilst observing a spectral display. The frequency of any emissions of interest was noted for formal measurement at the correct measurement distance of 1m. This procedure was repeated for all relevant transmit operating channels.

At a measurement distance of 1 meter the limit line was increased by  $20 \cdot \text{LOG}(3/1) = 9.54$  dB.

### 2.1.5 Example Test Setup Diagram

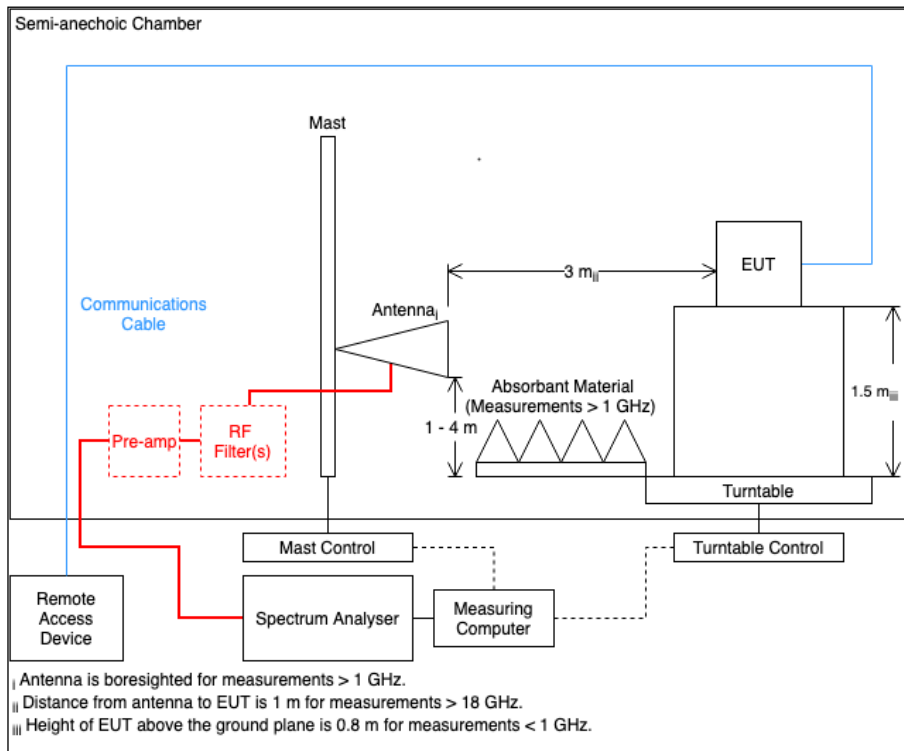


Figure 1

### 2.1.6 Environmental Conditions

Ambient Temperature	21.2 - 28.4 °C
Relative Humidity	54.6 - 59.0 %



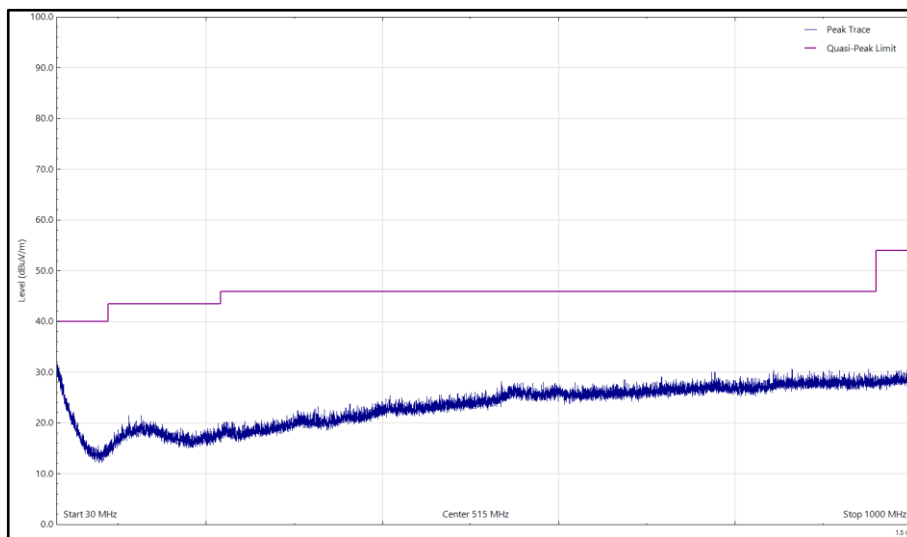
**2.1.7 Test Results**

CoTX - 5 GHz WLAN and 2.4 GHz WLAN and 2.4 GHz Bluetooth

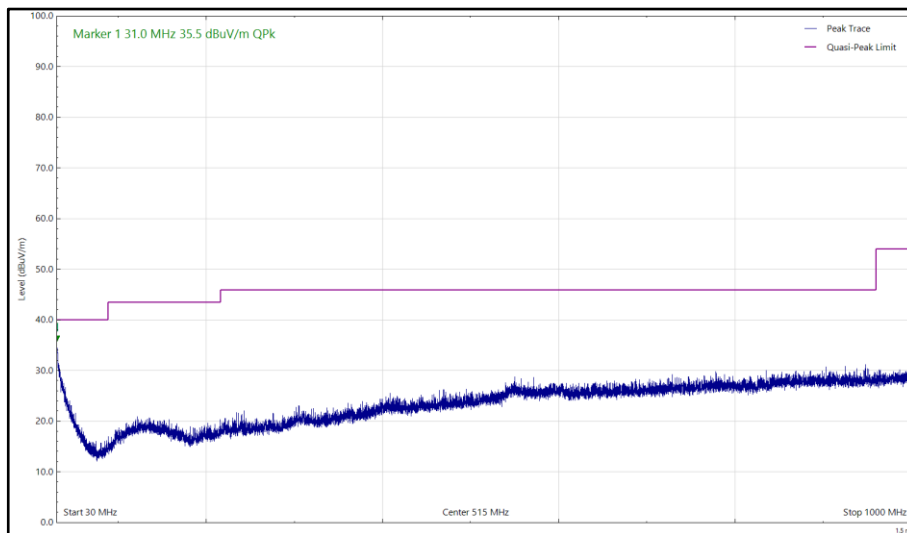
Frequency (MHz)	Level (dBuV/m)	Limit (dBuV/m)	Margin (dB)	Detector	Angle (°)	Height (cm)	Polarisation
31.009	35.5	40.0	-4.5	Q-Peak	276	400	Vertical

**Table 5 – 2417 MHz (CH2), HT20, CDD, Core 0 + Core 1 and 2480 MHz (CH78), DH5, ePA, Core 0, 30 MHz to 26 GHz**

No other emissions were detected within 10 dB of the limit.

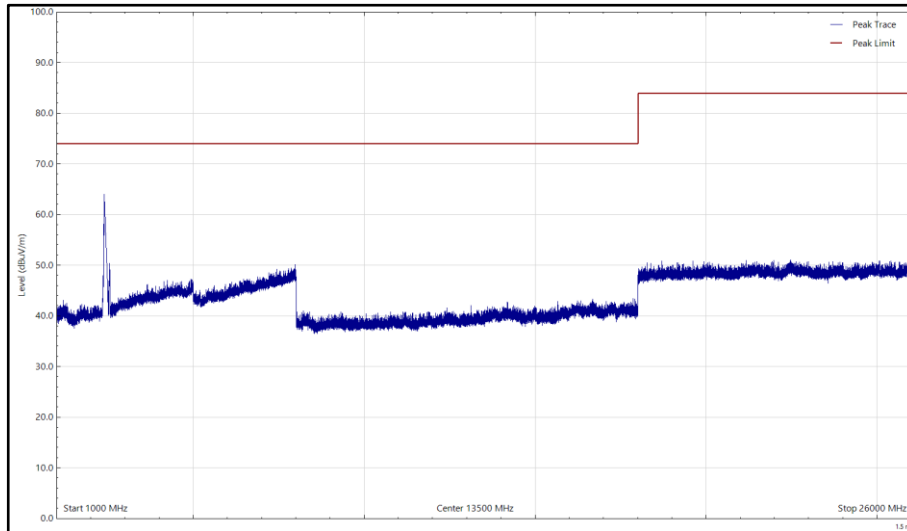


**Figure 2 – 2417 MHz (CH2), HT20, CDD, Core 0 + Core 1 and 2480 MHz (CH78), DH5, ePA, Core 0, 30 MHz to 1 GHz, Horizontal, Q-Peak**

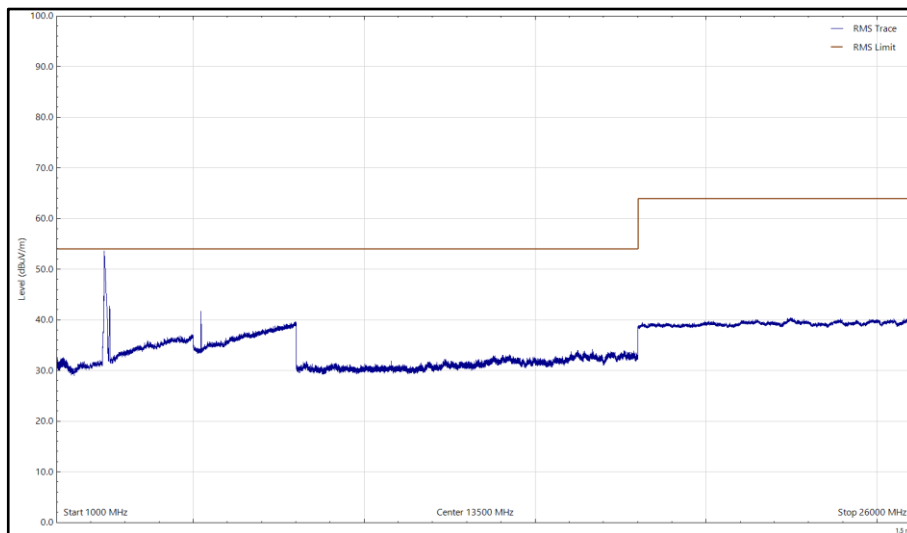


**Figure 3 – 2417 MHz (CH2), HT20, CDD, Core 0 + Core 1 and 2480 MHz (CH78), DH5, ePA, Core 0, 30 MHz to 1 GHz, Vertical, Q-Peak**

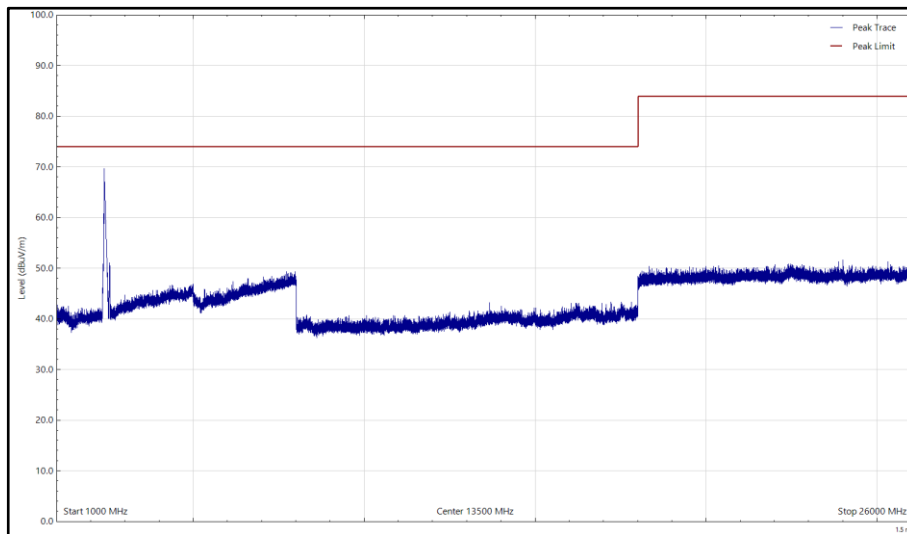




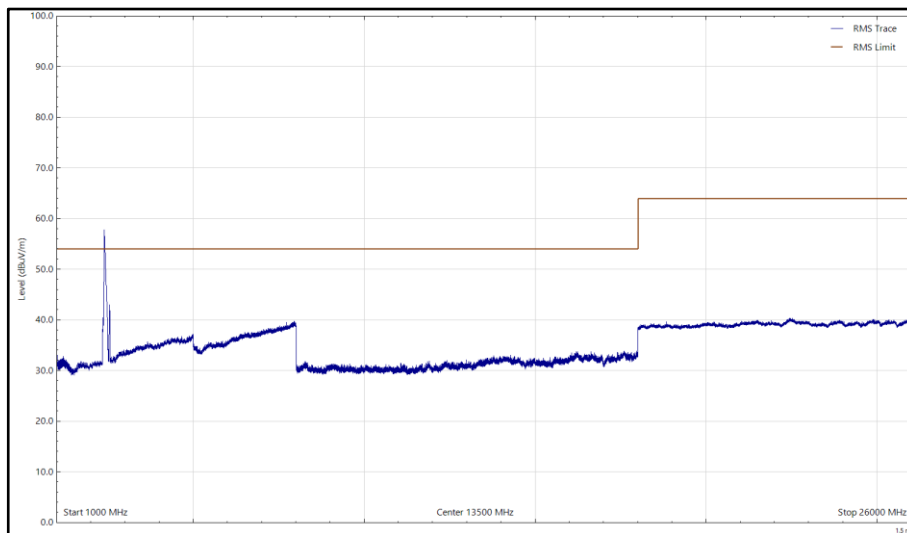
**Figure 4 – 2417 MHz (CH2), HT20, CDD, Core 0 + Core 1 and 2480 MHz (CH78), DH5, ePA, Core 0, 1 GHz to 26 GHz, Horizontal, Peak**



**Figure 5 – 2417 MHz (CH2), HT20, CDD, Core 0 + Core 1 and 2480 MHz (CH78), DH5, ePA, Core 0, 1 GHz to 26 GHz, Horizontal, Average**



**Figure 6 – 2417 MHz (CH2), HT20, CDD, Core 0 + Core 1 and 2480 MHz (CH78), DH5, ePA, Core 0, 1 GHz to 26 GHz, Vertical, Peak**



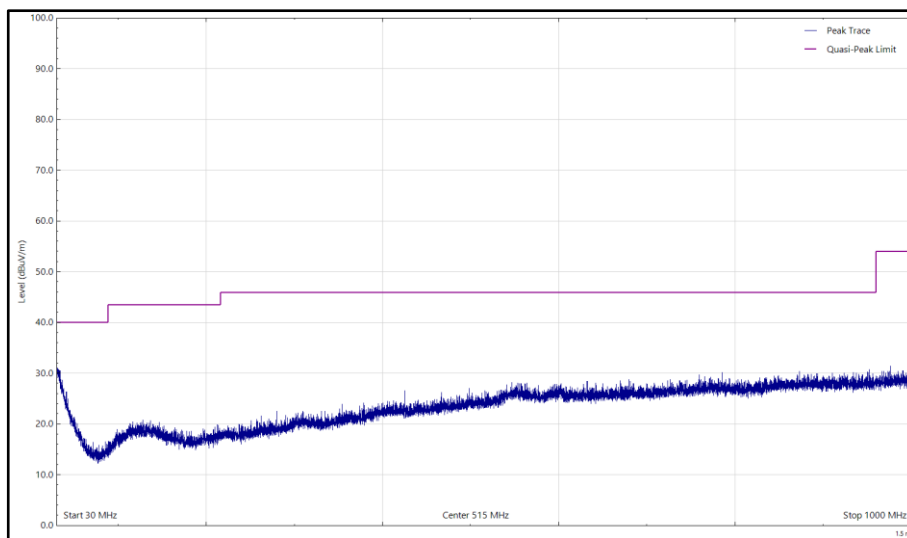
**Figure 7 – 2417 MHz (CH2), HT20, CDD, Core 0 + Core 1 and 2480 MHz (CH78), DH5, ePA, Core 0, 1 GHz to 26 GHz, Vertical, Average**



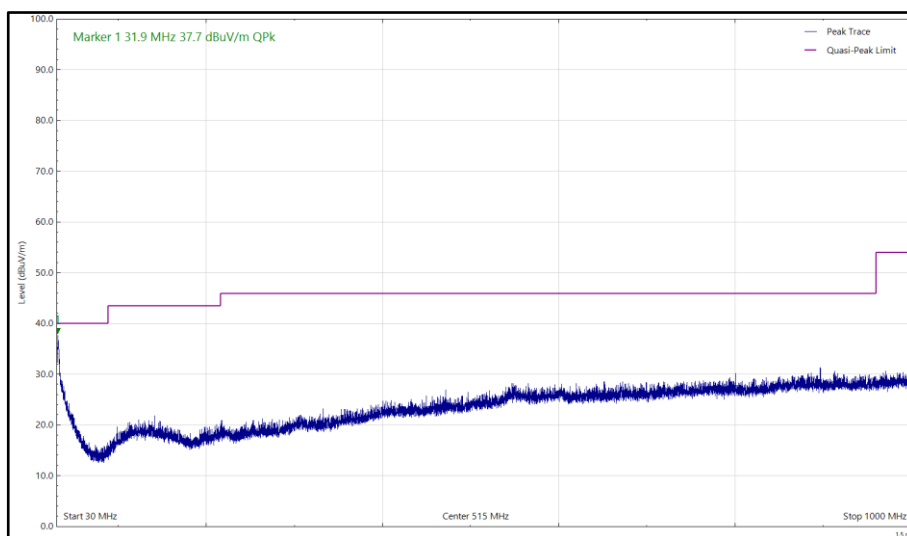
Frequency (MHz)	Level (dBuV/m)	Limit (dBuV/m)	Margin (dB)	Detector	Angle (°)	Height (cm)	Polarisation
31.888	37.7	40.0	-2.3	Q-Peak	301	400	Vertical
2345.461	54.8	74.0	-19.2	Peak	211	126	Horizontal
2346.030	46.7	54.0	-7.3	RMS	317	101	Vertical
2346.150	44.0	54.0	-10.0	RMS	211	126	Horizontal
2346.652	58.1	74.0	-15.9	Peak	317	101	Vertical

**Table 6 – 2452 MHz (CH9), HT20, CDD, Core 0 + Core 1 and 2402 MHz (CH0), DH5, ePA, Core 0, 30 MHz to 26 GHz Emissions Results**

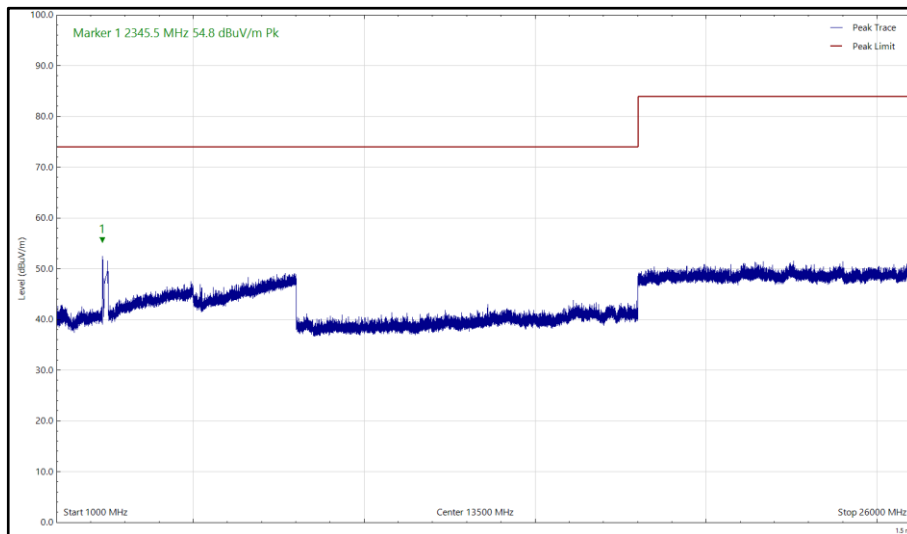
No other emissions were detected within 10 dB of the limit.



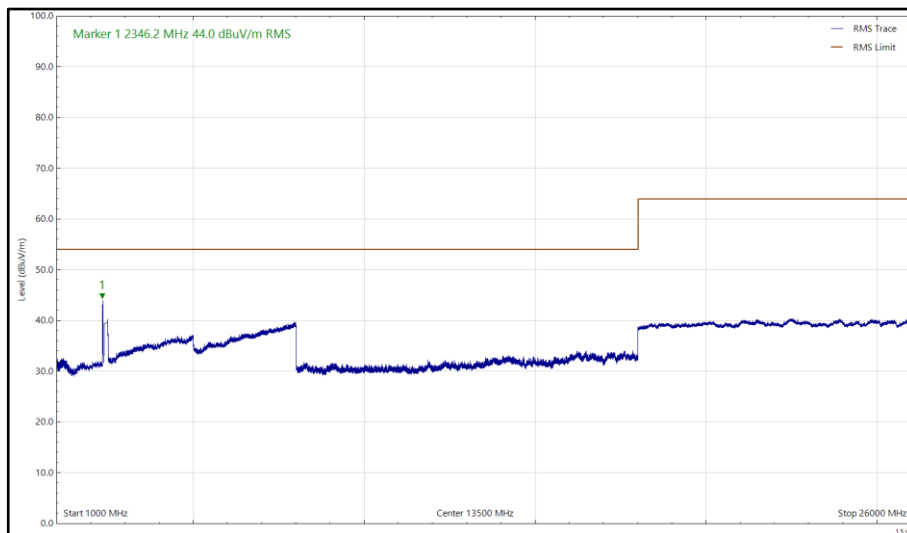
**Figure 8 – 2452 MHz (CH9), HT20, CDD, Core 0 + Core 1 and 2402 MHz (CH0), DH5, ePA, Core 0, 30 MHz to 1 GHz, Horizontal, Q-Peak**



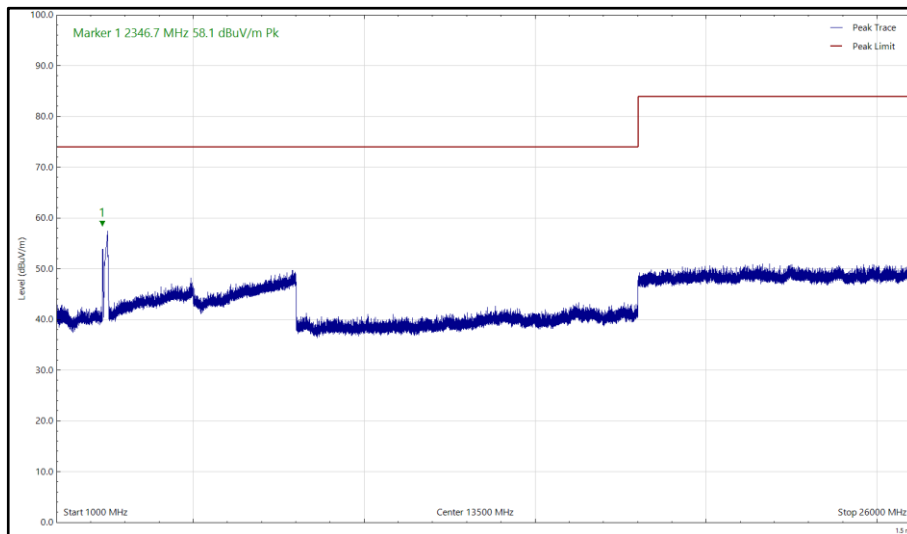
**Figure 9 – 2452 MHz (CH9), HT20, CDD, Core 0 + Core 1 and 2402 MHz (CH0), DH5, ePA, Core 0, 30 MHz to 1 GHz, Vertical, Q-Peak**



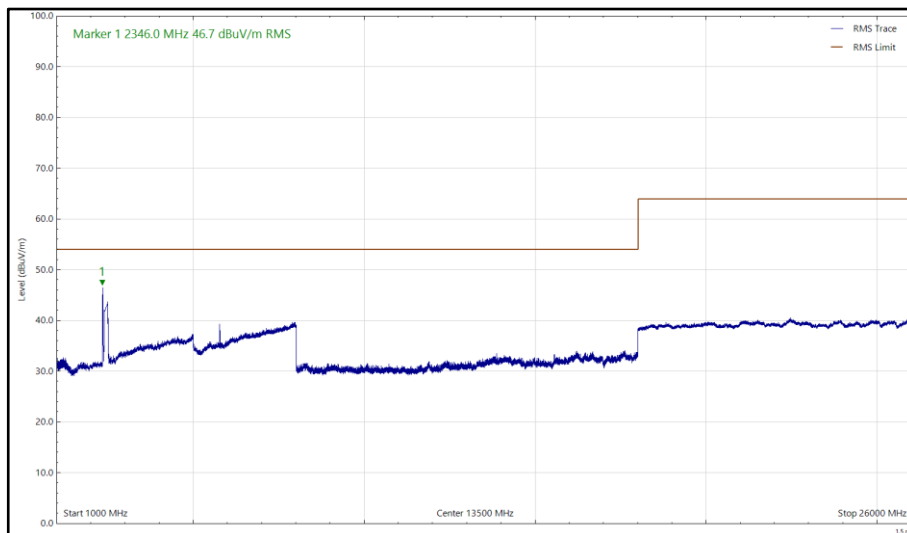
**Figure 10 – 2452 MHz (CH9), HT20, CDD, Core 0 + Core 1 and 2402 MHz (CH0), DH5, ePA, Core 0, 1 GHz to 26 GHz, Horizontal, Peak**



**Figure 11 – 2452 MHz (CH9), HT20, CDD, Core 0 + Core 1 and 2402 MHz (CH0), DH5, ePA, Core 0, 1 GHz to 26 GHz, Horizontal, Average**



**Figure 12 – 2452 MHz (CH9), HT20, CDD, Core 0 + Core 1 and 2402 MHz (CH0), DH5, ePA, Core 0, 1 GHz to 26 GHz, Vertical, Peak**



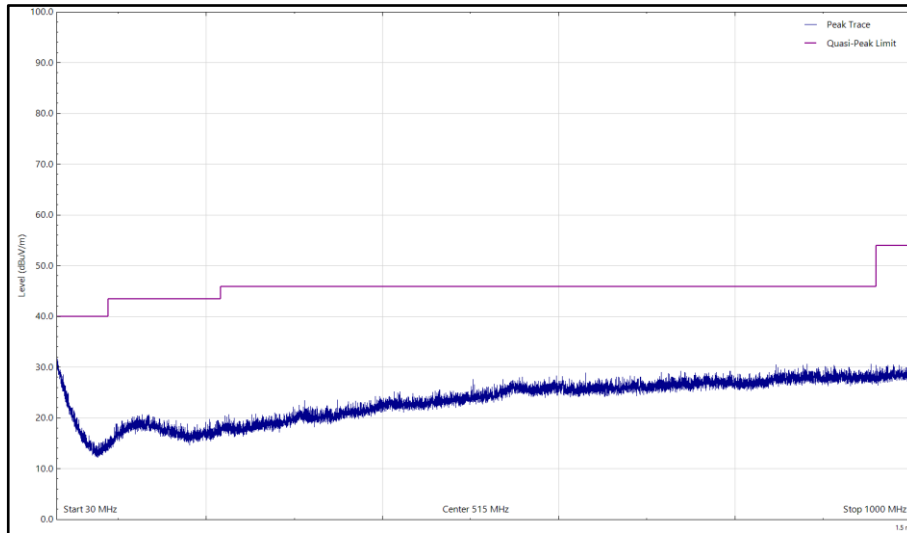
**Figure 13 – 2452 MHz (CH9), HT20, CDD, Core 0 + Core 1 and 2402 MHz (CH0), DH5, ePA, Core 0, 1 GHz to 26 GHz, Vertical, Average**



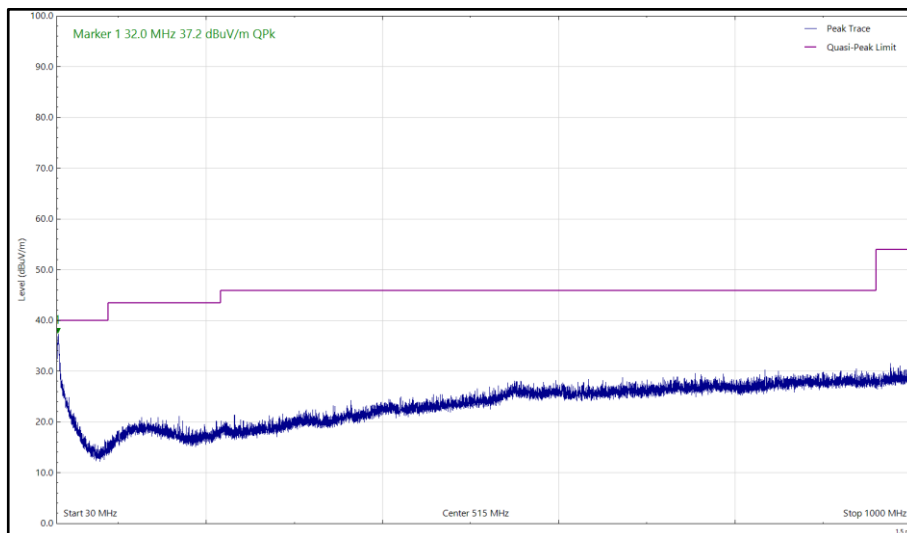
Frequency (MHz)	Level (dBuV/m)	Limit (dBuV/m)	Margin (dB)	Detector	Angle (°)	Height (cm)	Polarisation
31.965	37.2	40.0	-2.8	Q-Peak	316	390	Vertical

**Table 7 – U-NII 1 5200 MHz (CH40), HT20, CDD, Core 0 + Core 1 and 2480 MHz (CH78), DH5, ePA, Core 0, 30 MHz to 40 GHz Emissions Results**

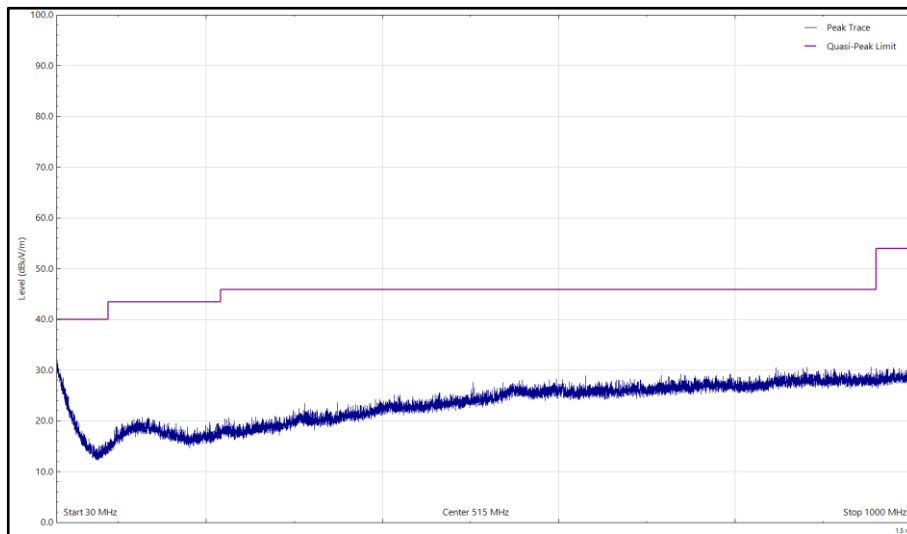
No other emissions were detected within 10 dB of the limit.



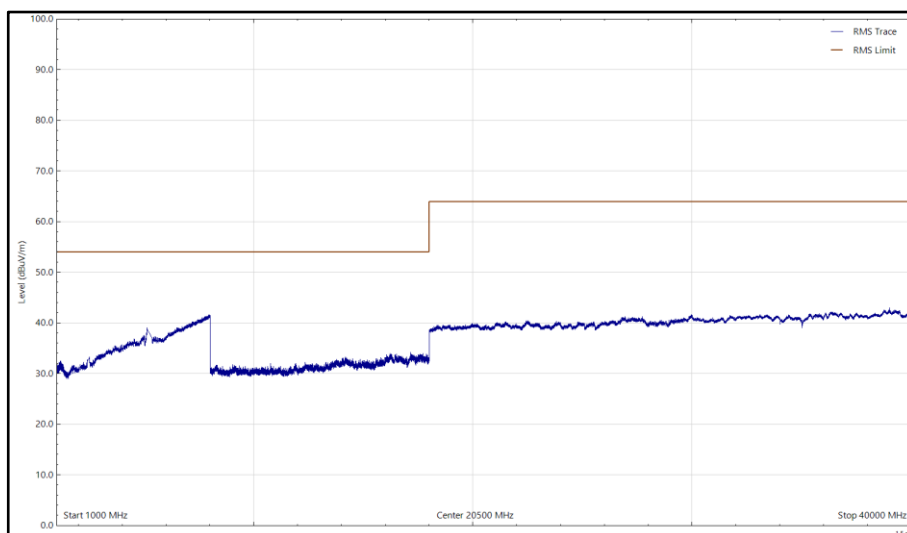
**Figure 14 – U-NII 1 5200 MHz (CH40), HT20, CDD, Core 0 + Core 1 and 2480 MHz (CH78), DH5, ePA, Core 0, 30 MHz to 1 GHz, Horizontal, Q-Peak**



**Figure 15 – U-NII 1 5200 MHz (CH40), HT20, CDD, Core 0 + Core 1 and 2480 MHz (CH78), DH5, ePA, Core 0, 30 MHz to 1 GHz, Vertical, Q-Peak**



**Figure 16 – U-NII 1 5200 MHz (CH40), HT20, CDD, Core 0 + Core 1 and 2480 MHz (CH78), DH5, ePA, Core 0, 1 GHz to 40 GHz, Horizontal, Peak**



**Figure 17 – U-NII 1 5200 MHz (CH40), HT20, CDD, Core 0 + Core 1 and 2480 MHz (CH78), DH5, ePA, Core 0, 1 GHz to 40 GHz, Horizontal, Average**

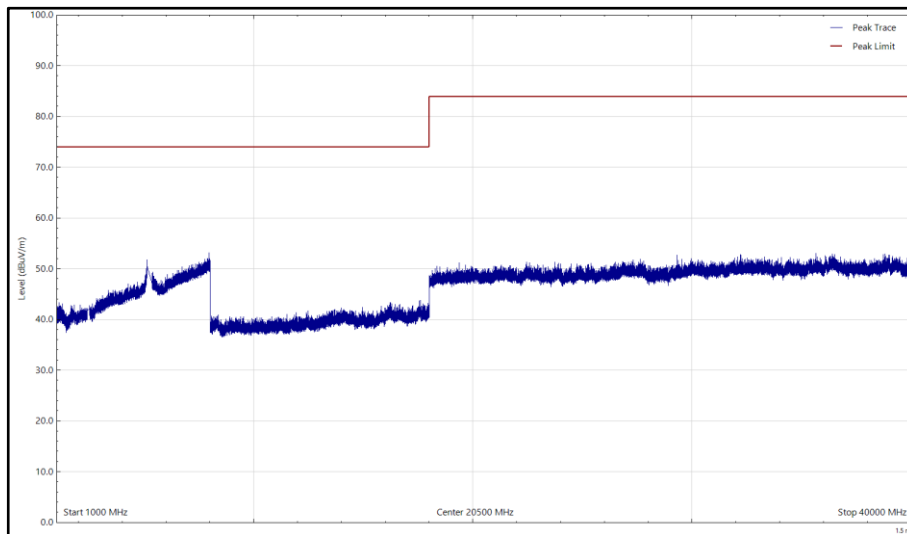


Figure 18 – U-NII 1 5200 MHz (CH40), HT20, CDD, Core 0 + Core 1 and 2480 MHz (CH78), DH5, ePA, Core 0, 1 GHz to 40 GHz, Vertical, Peak

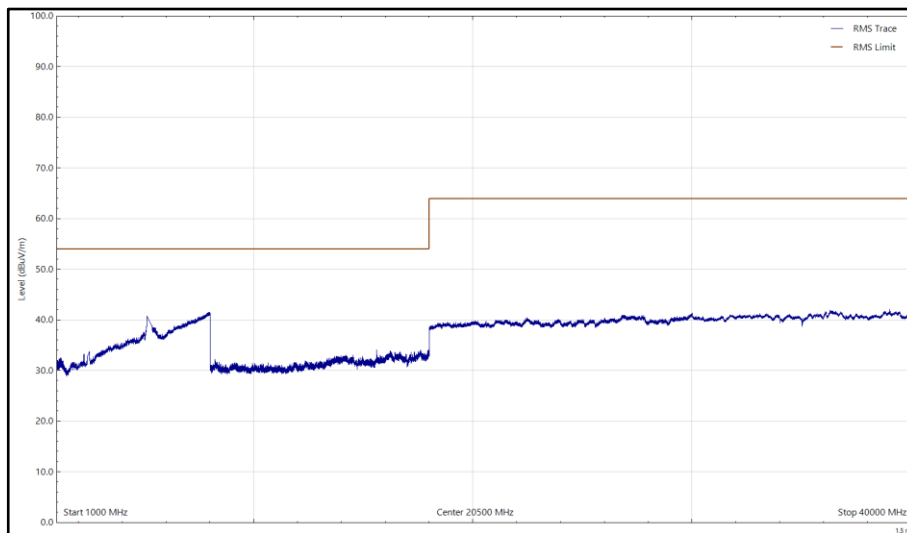


Figure 19 – U-NII 1 5200 MHz (CH40), HT20, CDD, Core 0 + Core 1 and 2480 MHz (CH78), DH5, ePA, Core 0, 1 GHz to 40 GHz, Vertical, Average

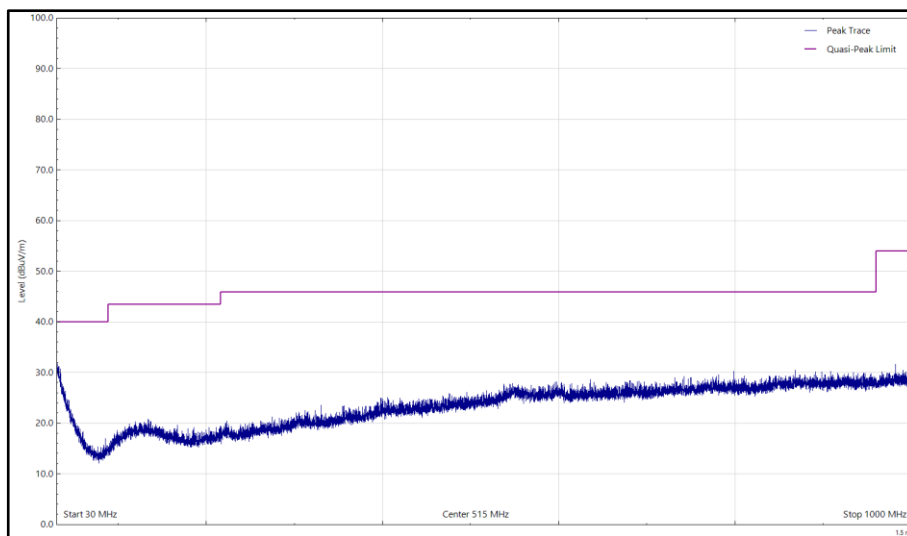




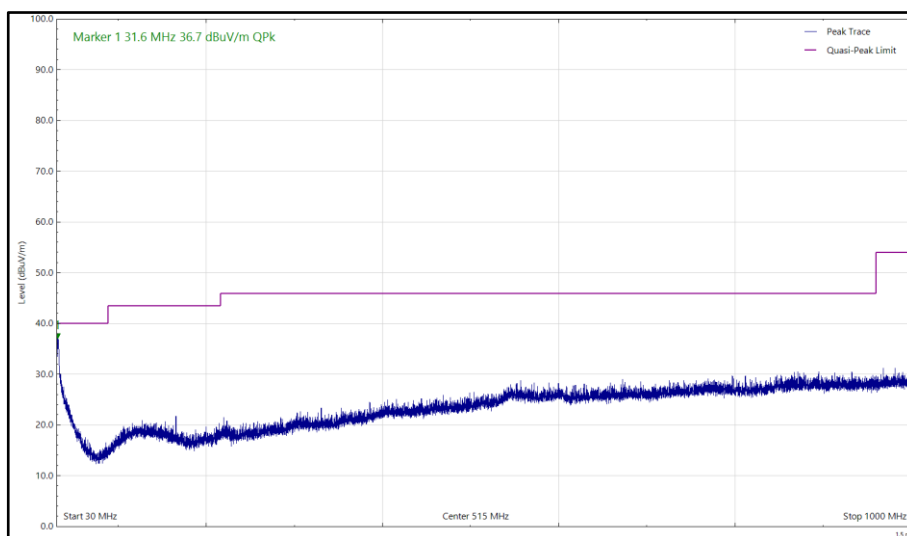
Frequency (MHz)	Level (dBuV/m)	Limit (dBuV/m)	Margin (dB)	Detector	Angle (°)	Height (cm)	Polarisation
31.556	36.7	40.0	-3.3	Q-Peak	119	380	Vertical
11357.446	35.0	54.0	-19.0	CISPR Avg	146	237	Vertical
11357.546	49.8	74.0	-24.2	Peak	244	221	Vertical
11362.762	31.2	54.0	-22.8	CISPR Avg	141	100	Horizontal
11365.107	47.0	74.0	-27.0	Peak	245	113	Horizontal

**Table 8 – U-NII 1 5680 MHz (CH138), HT20, CDD, Core 0 + Core 1 and 2402 MHz (CH0), DH5, ePA, Core 0, 30 MHz to 40 GHz Emissions Results**

No other emissions were detected within 10 dB of the limit.



**Figure 20 – U-NII 1 5680 MHz (CH138), HT20, CDD, Core 0 + Core 1 and 2402 MHz (CH0), DH5, ePA, Core 0, 30 MHz to 1 GHz, Horizontal, Q-Peak**



**Figure 21 – U-NII 1 5680 MHz (CH138), HT20, CDD, Core 0 + Core 1 and 2402 MHz (CH0), DH5, ePA, Core 0, 30 MHz to 1 GHz, Vertical, Q-Peak**

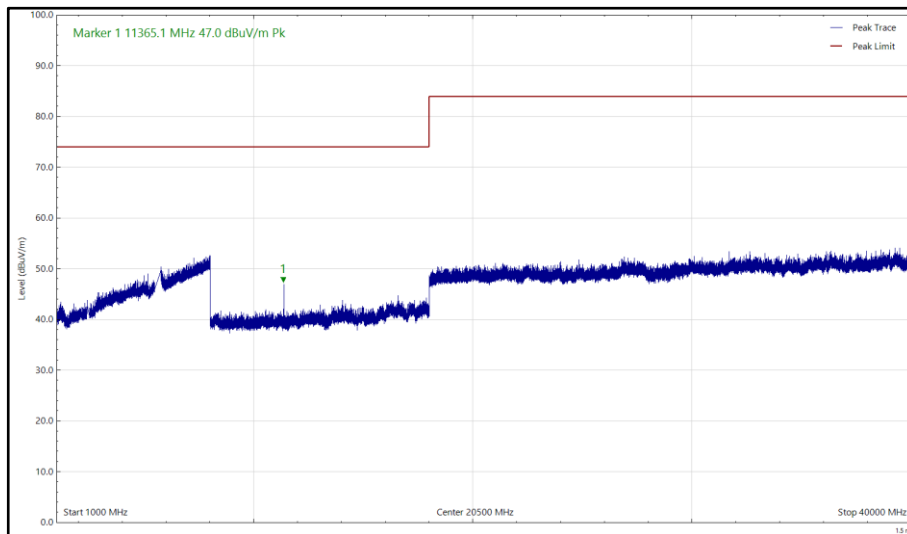


Figure 22 – U-NII 1 5680 MHz (CH138), HT20, CDD, Core 0 + Core 1 and 2402 MHz (CH0), DH5, ePA, Core 0, 1 GHz to 40 GHz, Horizontal, Peak

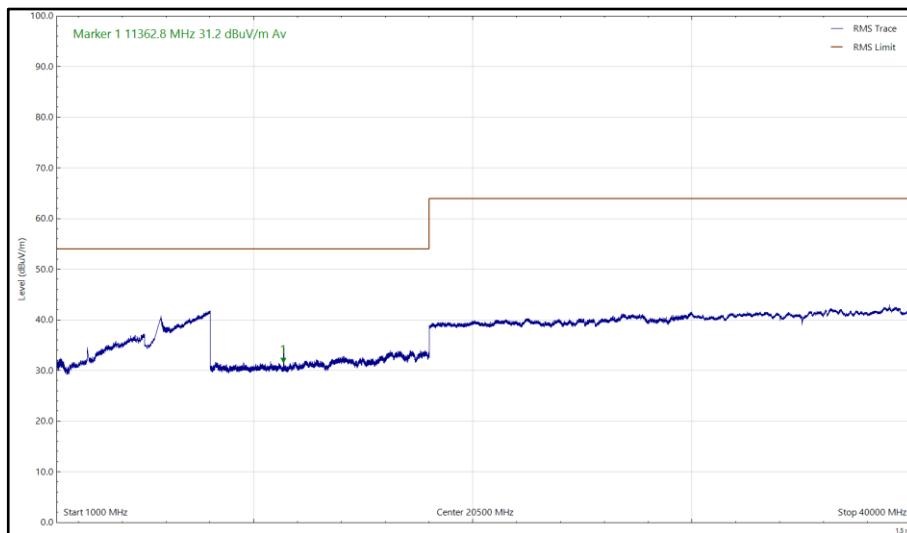


Figure 23 – U-NII 1 5680 MHz (CH138), HT20, CDD, Core 0 + Core 1 and 2402 MHz (CH0), DH5, ePA, Core 0, 1 GHz to 40 GHz, Horizontal, Average

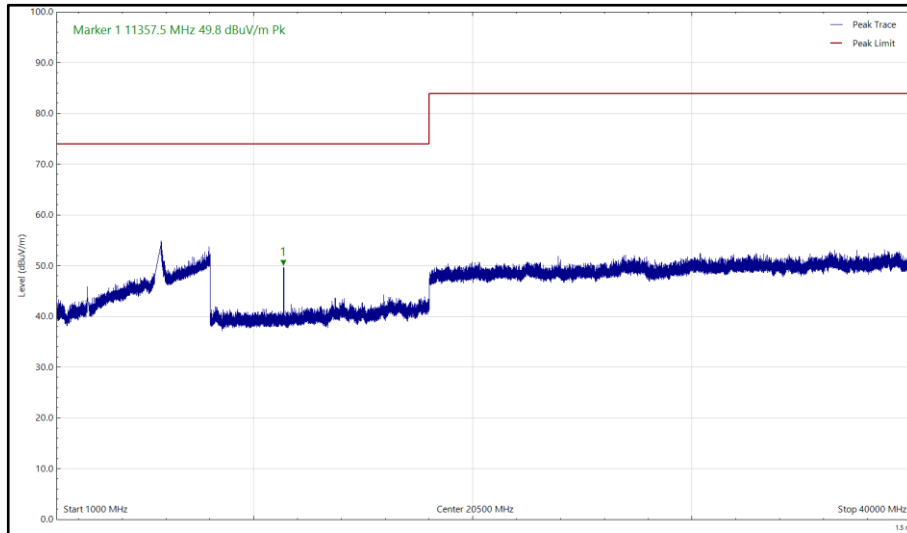


Figure 24 – U-NII 1 5680 MHz (CH138), HT20, CDD, Core 0 + Core 1 and 2402 MHz (CH0), DH5, ePA, Core 0, 1 GHz to 40 GHz, Vertical, Peak

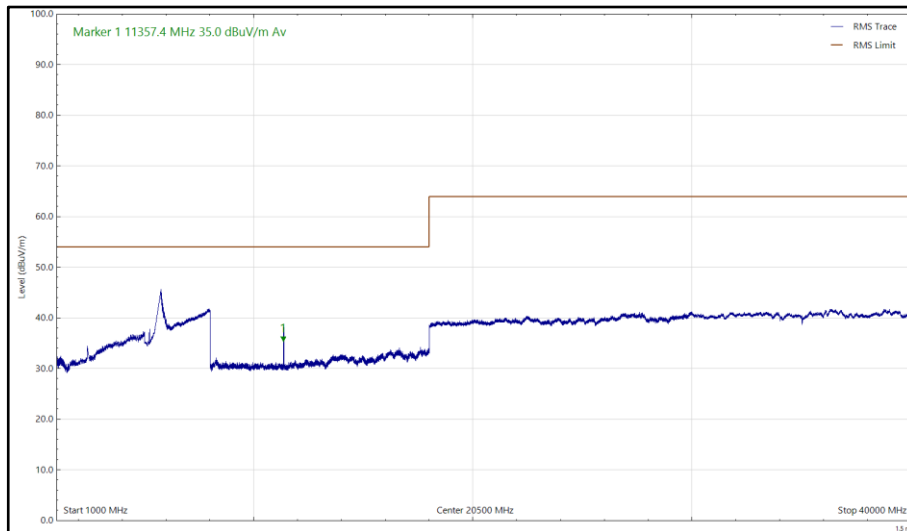


Figure 25 – U-NII 1 5680 MHz (CH138), HT20, CDD, Core 0 + Core 1 and 2402 MHz (CH0), DH5, ePA, Core 0, 1 GHz to 40 GHz, Vertical, Average

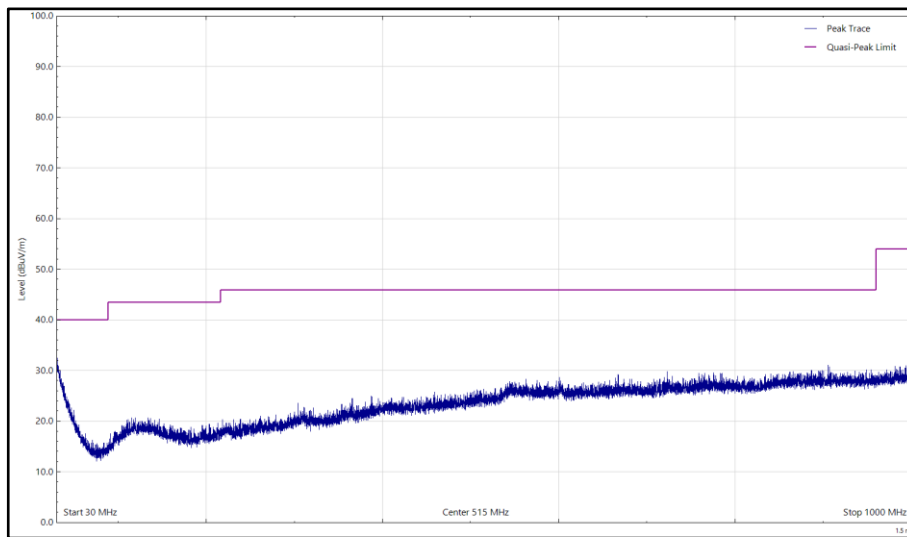


SDB - 2.4 GHz WLAN and 5 GHz WLAN

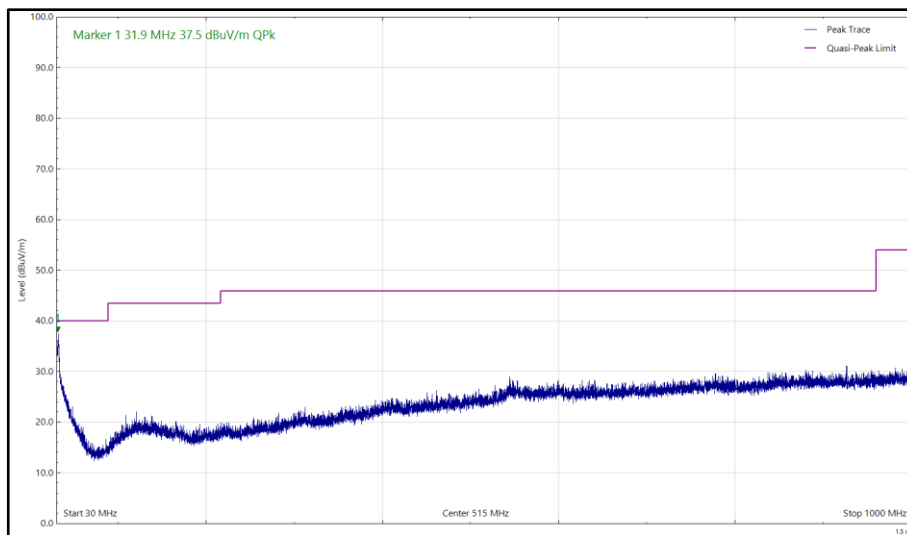
Frequency (MHz)	Level (dBuV/m)	Limit (dBuV/m)	Margin (dB)	Detector	Angle (°)	Height (cm)	Polarisation
31.891	37.5	40.0	-2.5	Q-Peak	267	399	Vertical

**Table 9 – 2417 MHz (CH2), HT20, CDD, Core 0 + Core 1 and U-NII 1 5200 MHz, HT20, CDD, Core 0 + Core 1, 30 MHz to 40 GHz Emissions Results**

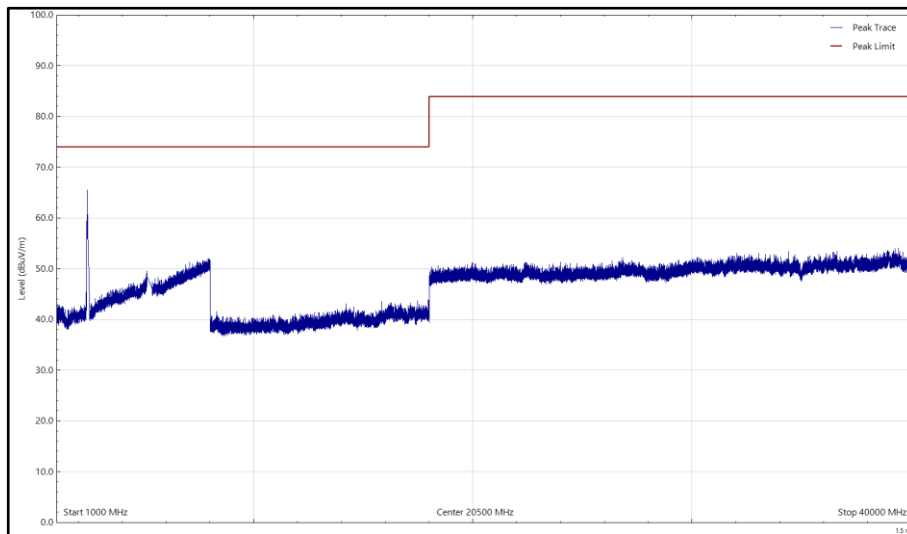
No other emissions were detected within 10 dB of the limit.



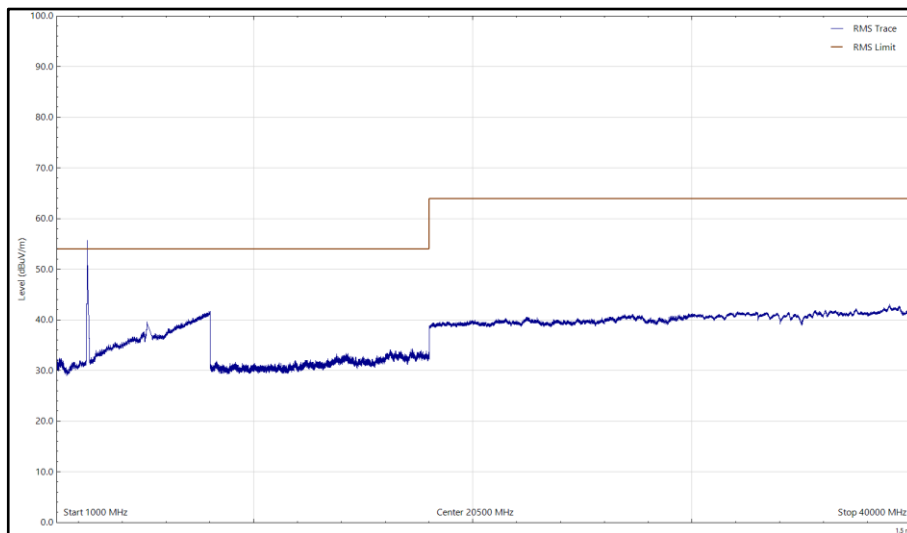
**Figure 26 – 2417 MHz (CH2), HT20, CDD, Core 0 + Core 1 and U-NII 1 5200 MHz, HT20, CDD, Core 0 + Core 1, 30 MHz to 1 GHz, Horizontal, Q-Peak**



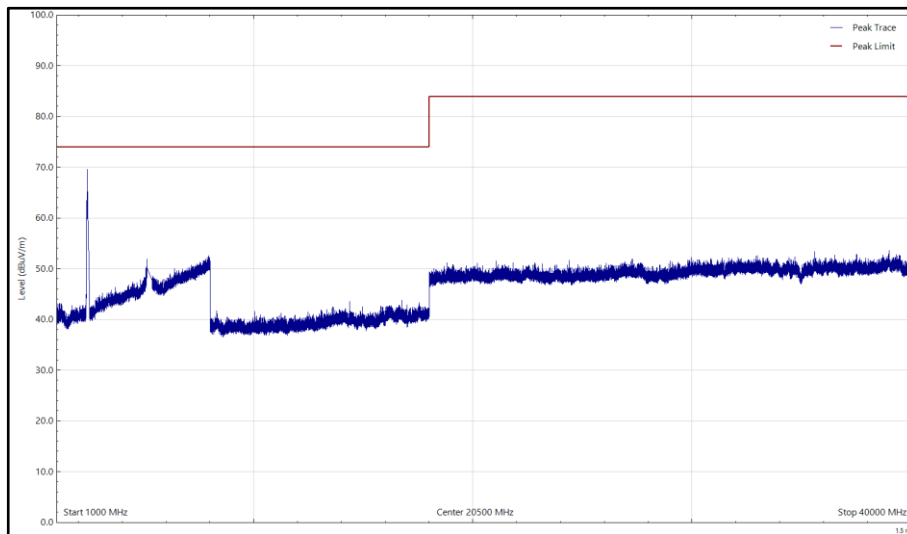
**Figure 27 – 2417 MHz (CH2), HT20, CDD, Core 0 + Core 1 and U-NII 1 5200 MHz, HT20, CDD, Core 0 + Core 1, 30 MHz to 1 GHz, Vertical, Q-Peak**



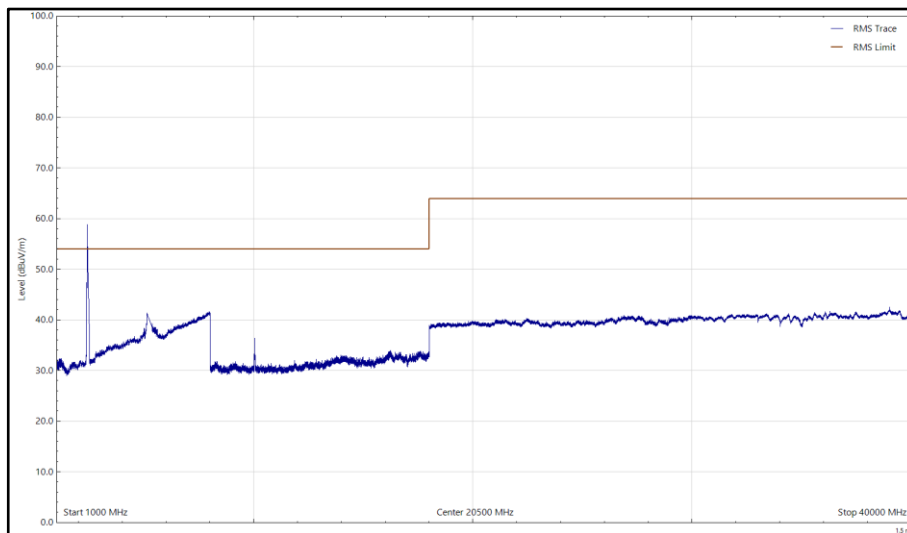
**Figure 28 – 2417 MHz (CH2), HT20, CDD, Core 0 + Core 1 and U-NII 1 5200 MHz, HT20, CDD, Core 0 + Core 1, 1 GHz to 40 GHz, Horizontal, Peak**



**Figure 29 – 2417 MHz (CH2), HT20, CDD, Core 0 + Core 1 and U-NII 1 5200 MHz, HT20, CDD, Core 0 + Core 1, 1 GHz to 40 GHz, Horizontal, Average**



**Figure 30 – 2417 MHz (CH2), HT20, CDD, Core 0 + Core 1 and U-NII 1 5200 MHz, HT20, CDD, Core 0 + Core 1, 1 GHz to 40 GHz, Vertical, Peak**



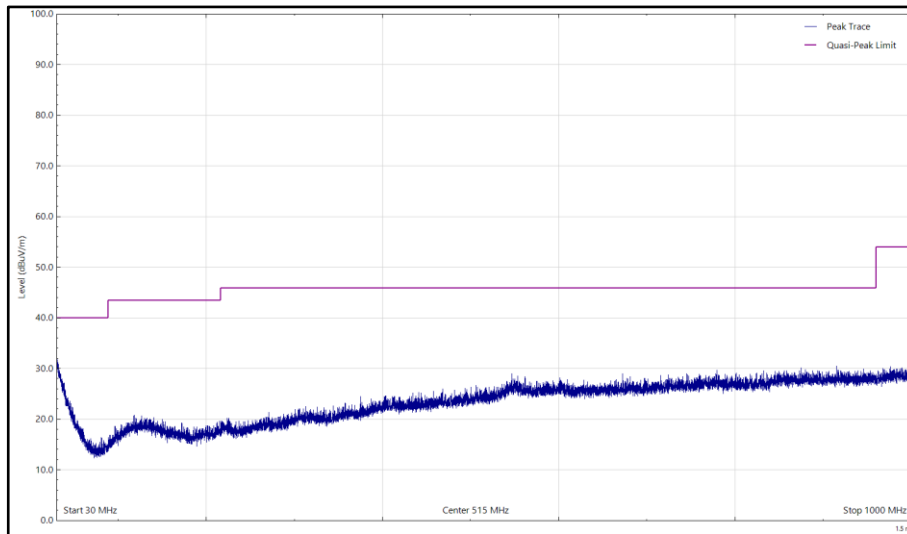
**Figure 31 – 2417 MHz (CH2), HT20, CDD, Core 0 + Core 1 and U-NII 1 5200 MHz, HT20, CDD, Core 0 + Core 1, 1 GHz to 40 GHz, Vertical, Average**



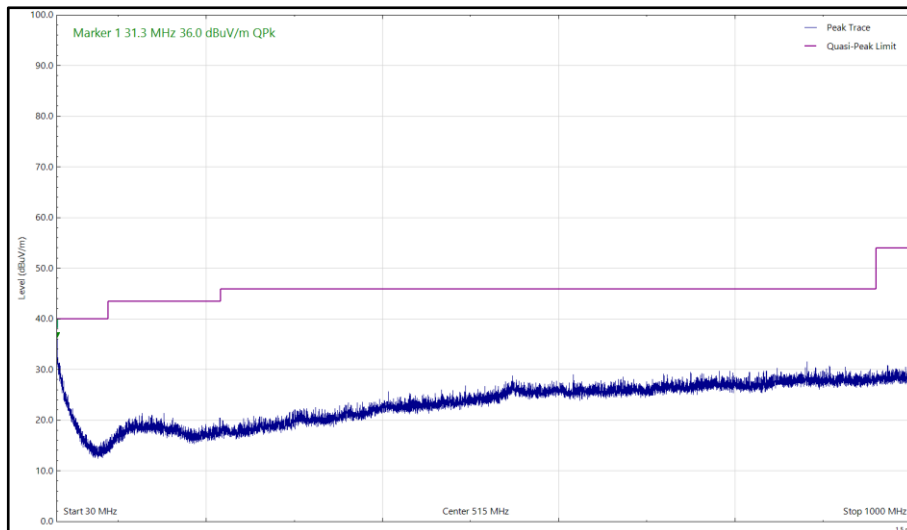
Frequency (MHz)	Level (dBuV/m)	Limit (dBuV/m)	Margin (dB)	Detector	Angle (°)	Height (cm)	Polarisation
31.270	36.0	40.0	-4.0	Q-Peak	7	392	Vertical
11359.962	37.2	54.0	-16.8	RMS	148	210	Vertical
11360.208	33.9	54.0	-20.1	RMS	141	113	Horizontal

**Table 10 – 2452 MHz (CH9), HT20, CDD, Core 0 + Core 1 and U-NII 1 5680 MHz (CH138), HT20 CDD, Core 0 + Core 1, 30 MHz to 40 GHz Emissions Results**

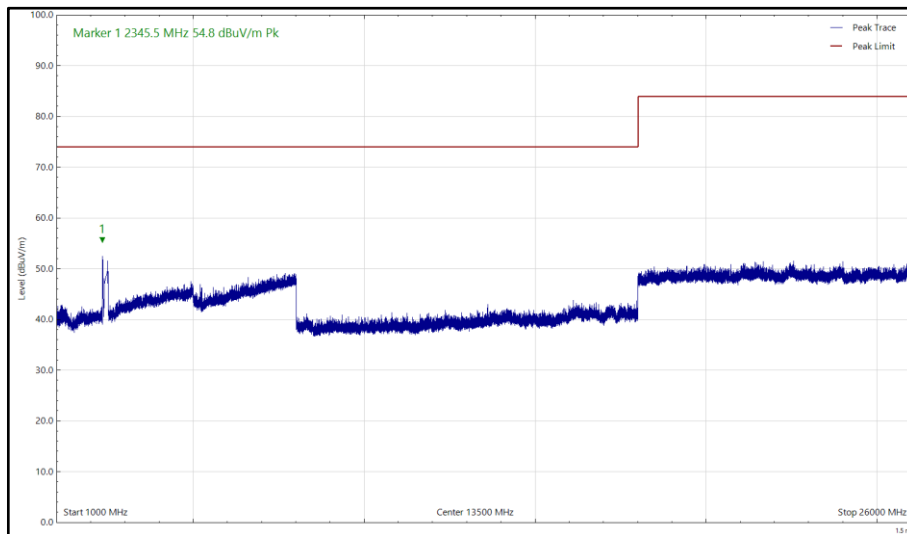
No other emissions were detected within 10 dB of the limit.



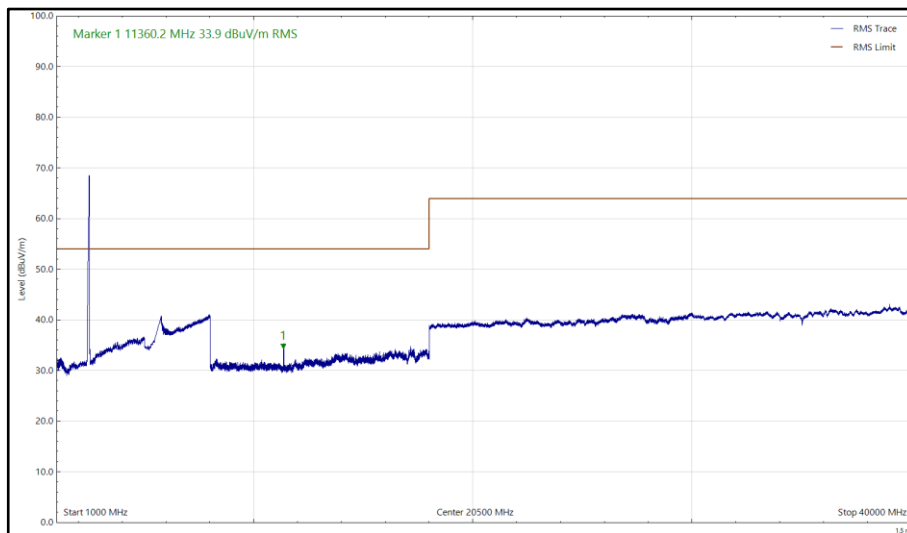
**Figure 32 – 2452 MHz (CH9), HT20, CDD, Core 0 + Core 1 and U-NII 1 5680 MHz (CH138), HT20 CDD, Core 0 + Core 1, 30 MHz to 1 GHz, Horizontal, Q-Peak**



**Figure 33 – 2452 MHz (CH9), HT20, CDD, Core 0 + Core 1 and U-NII 1 5680 MHz (CH138), HT20 CDD, Core 0 + Core 1, 30 MHz to 1 GHz, Vertical, Q-Peak**

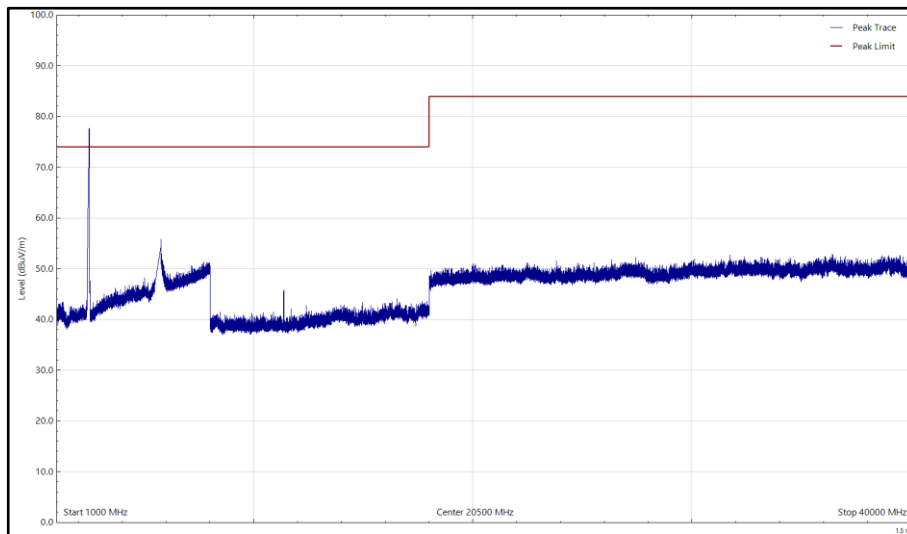


**Figure 34 – 2452 MHz (CH9), HT20, CDD, Core 0 + Core 1 and U-NII 1 5680 MHz (CH138), HT20 CDD, Core 0 + Core 1, 1 GHz to 40 GHz, Horizontal, Peak**

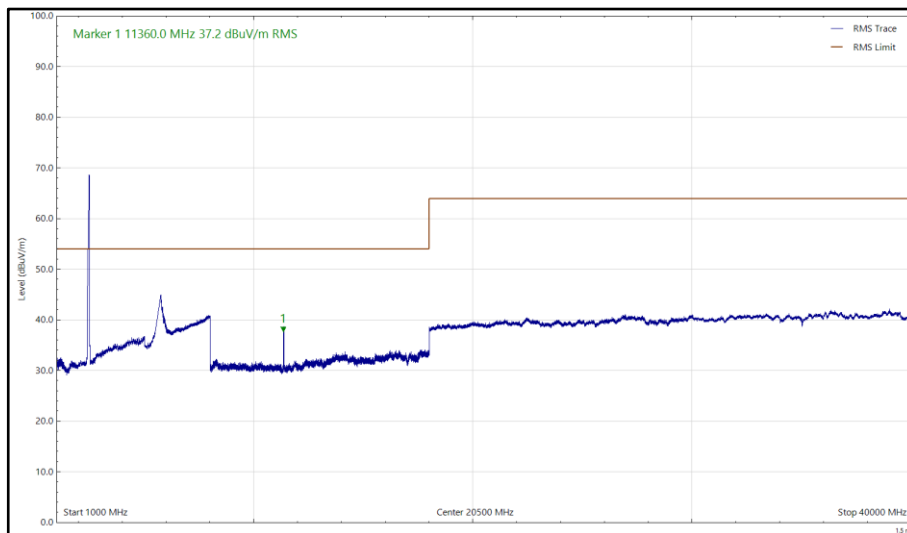


**Figure 35 – 2452 MHz (CH9), HT20, CDD, Core 0 + Core 1 and U-NII 1 5680 MHz (CH138), HT20 CDD, Core 0 + Core 1, 1 GHz to 40 GHz, Horizontal, Average**





**Figure 36 – 2452 MHz (CH9), HT20, CDD, Core 0 + Core 1 and U-NII 1 5680 MHz (CH138), HT20 CDD, Core 0 + Core 1, 1 GHz to 40 GHz, Vertical, Peak**



**Figure 37 – 2452 MHz (CH9), HT20, CDD, Core 0 + Core 1 and U-NII 1 5680 MHz (CH138), HT20 CDD, Core 0 + Core 1, 1 GHz to 40 GHz, Vertical, Average**



Limit Clause

The least stringent limit from the applicable rule parts was used to determine compliance for Radiated Emissions testing of multiple transmission sources.

Specification and Clause	Limit
FCC Part 15.247 (d)	-20 dBc
FCC Part 15.407 (b)	-27 dBm (EIRP) / 68.2 dBµV/m at 3 m
FCC Part 15.209 (Within restricted bands listed in 15.205)	Peak: 74 dBµV/m at 3 m Average 54 dBµV/m at 3 m
ISED RSS-247, Clause 5.5	-20 dBc
ISED RSS-247, Clause 6.2	-27 dBm (EIRP) / 68.2 dBµV/m at 3 m
ISED RSS-GEN, Clause 8.9 (Within restricted bands listed in clause 8.8)	Peak: 74 dBµV/m at 3 m Average 54 dBµV/m at 3 m

**Table 11 - Limit Table**



### 2.1.8 Test Location and Test Equipment Used

This test was carried out in RF Chamber 11.

Instrument	Manufacturer	Type No	TE No	Calibration Period (months)	Calibration Due
Power Supply Unit	Farnell	LB30-4	158	-	O/P Mon
Antenna 18-40GHz (Double Ridge Guide)	Link Microtek Ltd	AM180HA-K-TU2	230	24	27-Jul-2022
Antenna 18-40GHz (Double Ridge Guide)	Q-Par Angus Ltd	QSH 180K	1511	24	2-Oct-2021
18GHz - 40GHz Pre-Amplifier	Phase One	PSO4-0087	1534	12	18-Feb-2021
Antenna with permanent attenuator (Bilog)	Schaffner	CBL6143	2904	24	28-Nov-2021
Band Reject Filter - 2.425 GHz	Wainwright	WRCGV14-2390-2400-2450-2460-50SS	5066	12	1-Oct-2020
Band Reject Filter - 2.4585 GHz	Wainwright	WRCGV14-2423.5-2433.5-2483.5-2493.5-50SS	5068	12	1-Oct-2020
Band Reject Filter - 5.22 GHz	Wainwright	WRCJV12-5120-5150-5290-5320-50SS	5072	12	24-Sep-2020
Band Reject Filter - 5.690 GHz	Wainwright	WRCJV8-5635-5670-5710-5745-50SS	5080	12	25-Sep-2020
EMI Test Receiver	Rohde & Schwarz	ESW44	5084	12	28-Nov-2020
Cable (18 GHz)	Rosenberger	LU7-071-1000	5102	12	6-Oct-2020
Cable (18 GHz)	Rosenberger	LU7-071-1000	5103	12	6-Oct-2020
Cable (18 GHz)	Rosenberger	LU7-071-1000	5104	12	9-Dec-2020
Cable (18 GHz)	Rosenberger	LU7-071-1000	5105	12	6-Oct-2020
EmX Emissions Software	TUV SUD	EmX V.V1.6.3	5125	-	N/A - Software
Screened Room (11)	Rainford	Rainford	5136	36	1-Nov-2021
Mast	Maturo	TAM 4.0-P	5158	-	TU
Mast and Turntable Controller	Maturo	Maturo NCD	5159	-	TU
Turntable	Maturo	TT 15WF	5160	-	TU
Horn Antenna (1-10GHz)	Schwarzbeck	BBHA 9120 B	5215	12	10-Mar-2021
DRG Horn Antenna (7.5-18GHz)	Schwarzbeck	HWRD750	5216	12	10-Mar-2021
Pre Amp 1 - 26.5 GHz	Agilent Technologies	8449B	5445	12	6-May-2021
1m K-Type Cable	Junkosha	MWX241-01000KMSKMS/A	5512	12	3-Apr-2021
2m SMA Cable	Junkosha	MWX221-02000AMSAMS/A	5518	12	1-Apr-2021



8m N Type Cable	Junkosha	MWX221-08000NMSNMS/B	5522	12	24-Mar-2021
2m K Type Cable	Junkosha	MWX241-02000KMSKMS/A	5524	12	3-Apr-2021
7 GHz High pass Filter	Wainwright	WHKX12-5850-6800-18000-80SS	5550	12	23-May-2021
1200 MHz Low Pass Filter (02)	Mini-Circuits	VLF-1200+	5560	12	23-May-2021
8 - 18 GHz Amplifier	Wright Technologies	APS06-0061	5595	12	25-Aug-2021

**Table 12**

TU – Traceability Unscheduled



### 3 Measurement Uncertainty

For a 95% confidence level, the measurement uncertainties for defined systems are:

Test Name	Measurement Uncertainty
Radiated Spurious Emissions (Simultaneous Transmission)	30 MHz to 1 GHz: $\pm 5.2$ dB 1 GHz to 40 GHz: $\pm 6.3$ dB

**Table 13**

#### Measurement Uncertainty Decision Rule

Determination of conformity with the specification limits is based on the decision rule according to IEC Guide 115: 2007, clause 4.4.3 and 4.5.1.