



mmWave MPE (Averaged Power Density) Simulation

1	Introduction	2
2	MPE Simulation Methodology.....	2
3	MPE Measurements	3
4	MPE Simulations.....	4
5	Uncertainty Budget for Simulation	10
6	Simulation versus Measurement	10
	Appendix A: Worst Phase Derivation for Beam Pair	26
	Appendix B: 4 cm ² Averaged PD and Scaling Factor	27
	Appendix C: Simulated PD Distribution Plots.....	49



1 Introduction

This document provides an overview of the methodology used for Maximum Permissible Exposure (MPE) compliance of the 5G mmWave radios on next generation iPad. In the mmWave regime that this product will cover, the MPE is best represented by peak spatial-average power density (psPD).

Due to the presence of multiple antenna arrays and multiple antenna beams for each antenna array, we propose to use a combination of simulations and measurements to demonstrate MPE compliance. At a high level, the discussion is grouped into the following topics:

- Brief introduction to MPE simulation methodologies
- Explanation of the approach to demonstrate MPE (psPD) compliance in a device using measurements
- Brief review of the device configuration and operation, and detailed description of the simulation methodology and results

2 MPE Simulation Methodology

3D full-wave simulation is used to evaluate MPE for each antenna array module's beam. Each beam is created by invoking a pre-defined codebook that has the proper array elements' excitation (i.e., magnitude and phase) to create the beam.

The following steps are taken to verify the validity of the model used for MPE simulations and then the verified model is used for the MPE calculations:

1) EM Simulation:

- Import a CAD model that represents the actual product in the simulation tool
- Define material properties inside the product based on vendor's inputs
- Perform mesh seeding and solve

2) Apply Codebook:

- Apply array elements' excitation from the codebook and extract the fields
- Codebook shows the magnitude and phase of each antenna element, which determines each beam of the antenna array
- Codebook is generated to automate the simulation for different beams

3) MPE Calculations:

- Post-process the extracted fields including averaging the power density on the evaluation surface
- Averaging area is 4cm^2
- Calculate average power density (MPE)

4) Validate Simulation Model:

- Measure MPE
- Compare measurement vs simulation
- Once a correlation is established, and model's accuracy is verified, this model will be used for computational MPE assessments

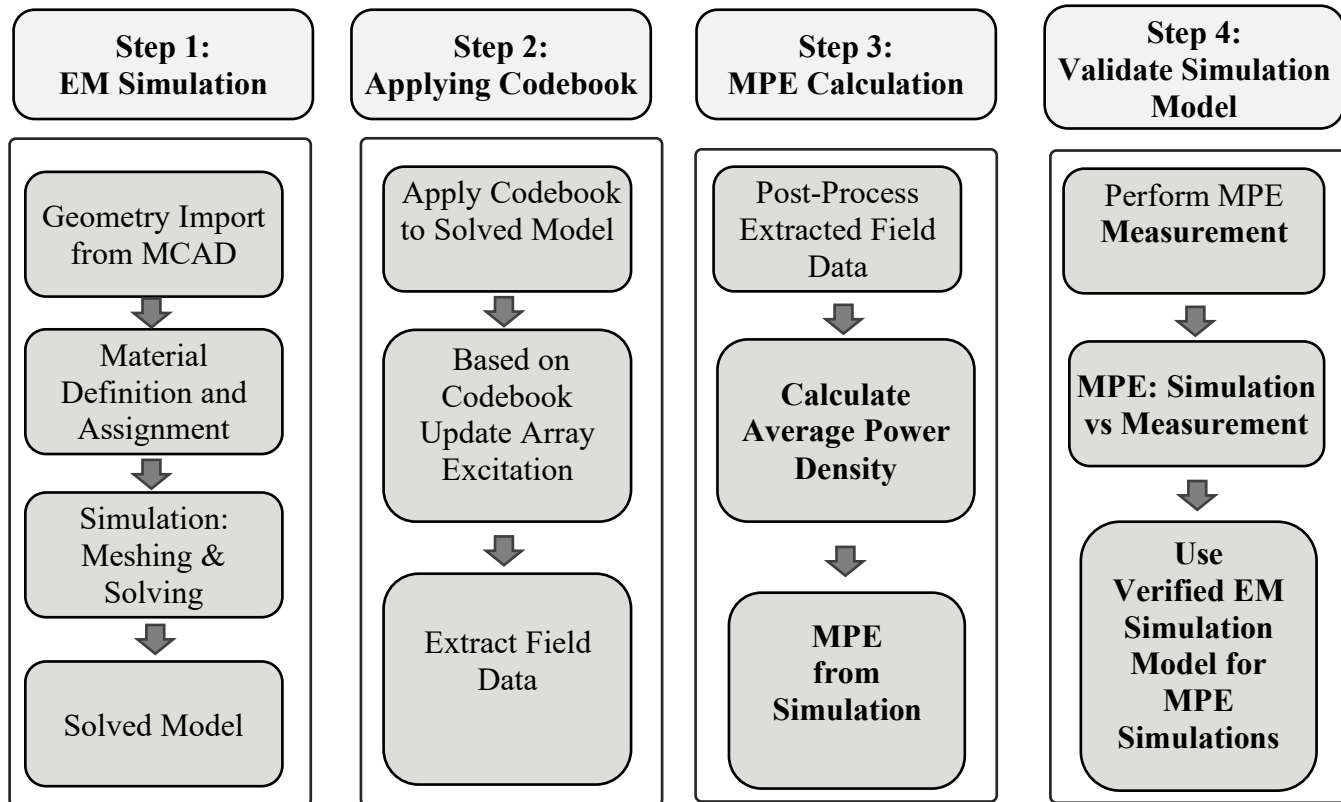

Figure 1. Model validation workflow for MPE simulation and evaluation.

3 MPE Measurements

A mmWave DAE SN 1411 module from SPEAG is used to measure the MPE above the DUT. Figure 2 shows the measurement setup. The mmWave E-field probe is used to measure the electric field above DUT. The near-field magnetic field and MPE are further obtained using this setup. For more details about the measurement algorithm, please refer to [1].

[1] S. Pfeifer, E. Carrasco, P. Crespo-Valero, E. Neufeld, S. Kuhn, T. Samaras, A. Christ, M. H. Capstick, and N. Kuster, "Total field reconstruction in the near field using pseudo-vector E-field measurement," *IEEE Trans. Electromagn. Compat.*, vol. 61, no. 2, pp. 476–486, Apr. 2019.

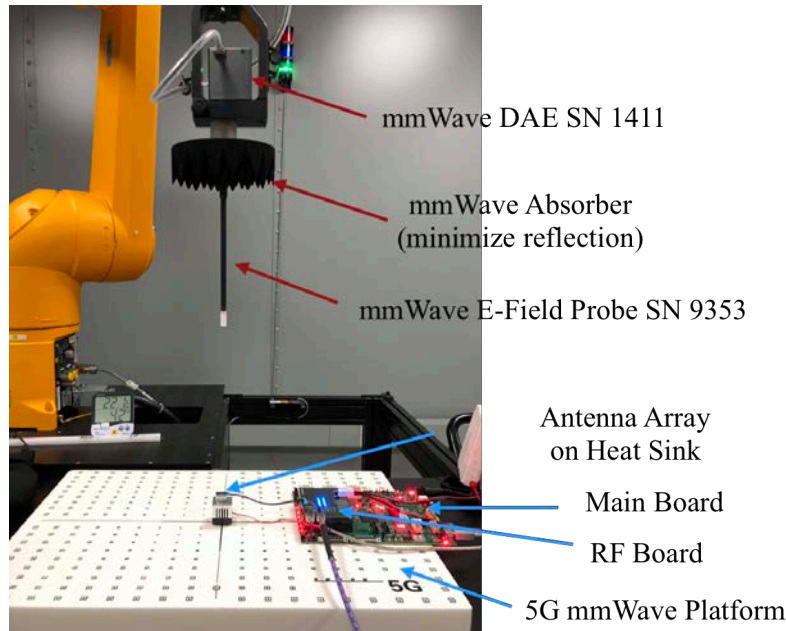

Figure 2. A representation of the MPE measurement setup.

The distance from the probe sensor tip to the edge of the housing is 1.5 mm, and there is 0.5 mm gap between the probe tip and the DUT surface to prevent any mechanical damages. Therefore, the closest distance that the setup can measure is 2 mm as shown below in Figure 3.

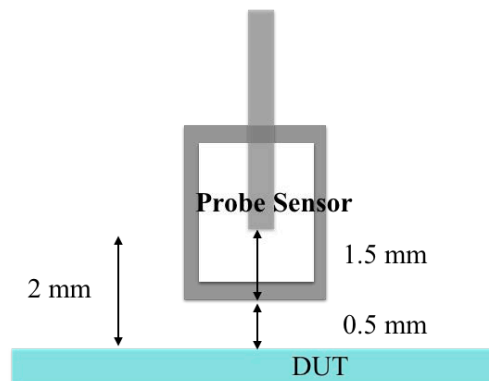

Figure 3. Schematic view of the probe showing that the minimum measurable distance is 2 mm.

4 MPE Simulations

In 5G, array antennas are designed to direct the beam to specific directions to improve link budgets. Most arrays can be configured by using the codebook with each code resulting in a different exposure. The number of codes in the codebook can be very large and measurements of all possible configurations have been shown to be impractical. Therefore, simulation is used to determine the configurations that result in the highest MPE.



Simulation Models

Figure 4 shows a schematic view of the iPad. There are three antenna arrays located at the top left corner, bottom right corner, and front. Arrays cover both horizontal and vertical polarizations.

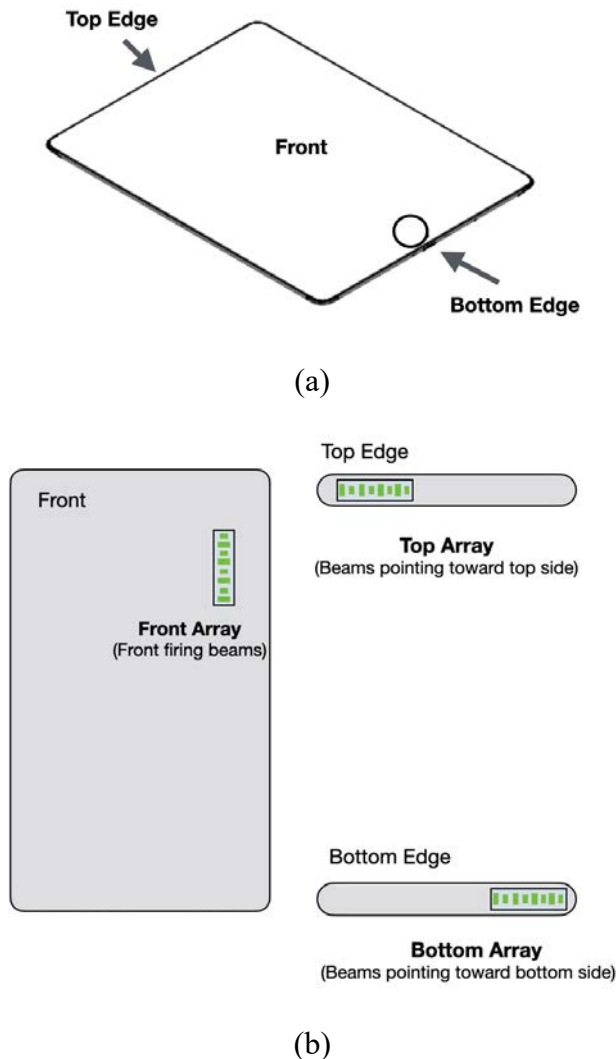

Figure 4. iPad schematic view (a) full view, (b) 5G arrays placement.

The measurements and simulations are correlated across different evaluation surfaces 2 mm away from each DUT surface, as shown in Fig. 5 (drawing not to scale). Six surfaces will be evaluated, respectively: front (S1), back (S2), left (S3), right (S4), top (S5), and bottom (S6). As Table 1 shows, for the three antenna modules, only the evaluation planes within 2.5 cm from the edges of the antenna modules will be considered. This does not apply to the front-to-back condition since the fields from the front module will be blocked at the back plane by the metal parts (such as battery, MLB) in between.

The “left” and “right” edges in the report are defined relative to the front of the device.

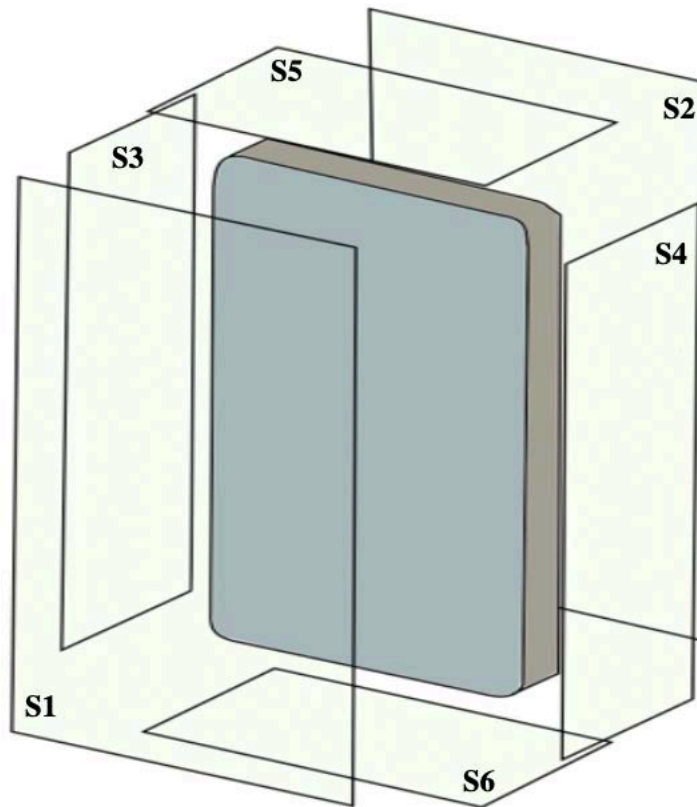

Figure 5. Evaluation surfaces for MPE (PD).

Table 1. PD Evaluation planes (any distance less than 1 cm is reported as 0 cm).

	Front (S1)	Rear (S2)	Left from Front View (S3)	Right from Front View (S4)	Top (S5)	Bottom (S6)
Top Module	Yes (0 cm)	Yes (0 cm)	Yes (0 cm)	No (14 cm)	Yes (0 cm)	No (24 cm)
Bottom Module	Yes (0 cm)	Yes (0 cm)	No (14 cm)	Yes (0 cm)	No (24 cm)	Yes (0 cm)
Front Module	Yes (0 cm)	Yes* (0 cm)	No (17 cm)	Yes (0 cm)	No (7 cm)	No (18 cm)

*MPE is reported but its value is very small because of the internal metallic objects' blockage.

Peak Spatial-Average Power Density Definition

After solving the 3D full-wave electromagnetic simulation, various physical quantities can be derived. To evaluate peak spatial-average power density, first, electric field \vec{E} and magnetic field \vec{H} are needed to calculate Poynting vector, as shown below:

$$\vec{S} = \frac{1}{2} \vec{E} \times \vec{H}^*$$



Having \vec{E} and \vec{H} values per mesh grid points from the simulation tool, we can calculate \vec{S} on a selected surface per each mesh grid point on that surface.

The peak spatial-average power density (psPD) on an evaluation area (A) can be calculated by performing an averaging as described, below:

$$\text{psPD} = \frac{1}{A} \int_A ||\text{Re}(\vec{S}) \cdot d\vec{A}|| = \frac{1}{2A} \int_A ||\text{Re}(\vec{E} \times \vec{H}^*) \cdot d\vec{A}||$$

Where $||\cdot||$ is the norm operation. The evaluated area A is 4 cm². To capture the worst-case conditions (i.e., highest psPD), simulations and measurements were performed assuming a 100% duty cycle.

Mesh and Convergence Criteria:

HFSS adapts the mesh based on the field gradient (variation) from one pass (iteration) to the next pass. The adaptive meshing process continues until the scattering matrix convergence criteria, ΔS , has achieved. Figure 6 is an example of the final adaptive mesh of a device. The simulation results of this report are all calculated with a ΔS target of 0.02.

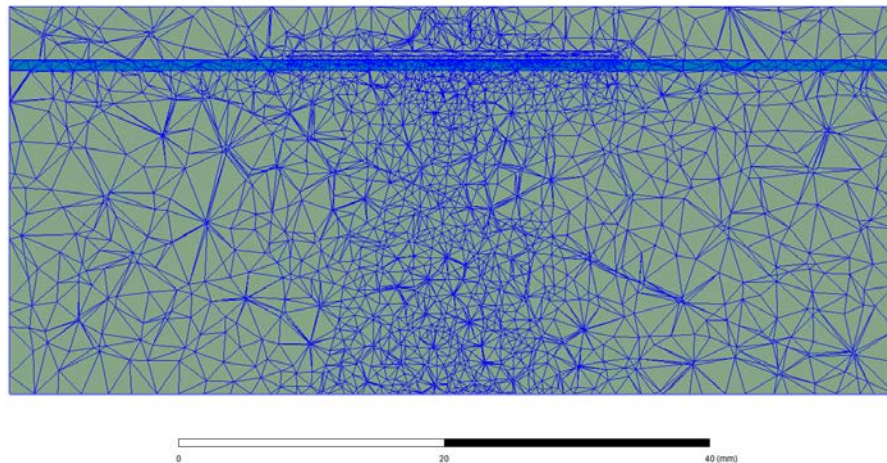

Figure 6. Example of the adaptive mesh technique.

It is important to make sure the mesh is refined to capture MPE or power density, accurately. This can be done by monitoring MPE levels vs different mesh densities, as Figure 7 depicts, showing that a fine enough mesh is needed to guarantee that the simulation achieves converged and correct results. The first row in Figure 7 is simulation with a coarse mesh, and the last row is with a fine mesh. From the results we can see that for the third mesh, the simulated result is within 1% of the result for the finest mesh. In these simulations, a refined mesh similar to the third row is applied to ensure an accurate result with the shortest processing time.

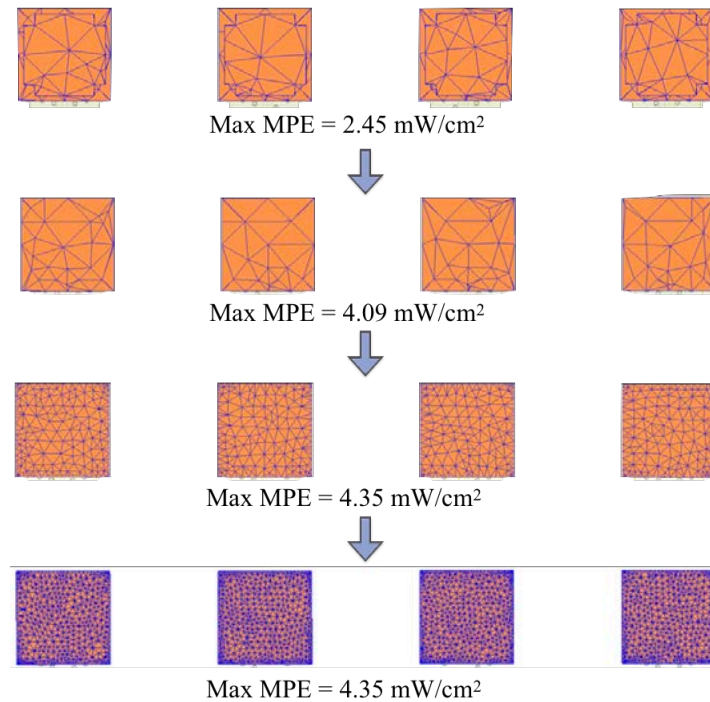

Figure 7. HFSS adaptive mesh shows that when the mesh is fine enough, MPE results will converge.

Boundary Conditions:

The boundary condition for simulating electromagnetic behavior in HFSS is to allow the electromagnetic waves to be electrically open at the boundary and radiated far away without reflection. HFSS can support the absorption boundary condition (ABC) for radiation boundary and normally requires a quarter-wavelength separation from the structure.

Source Excitation and Example Codebook:

Figure 8 shows an example of the codebook for the antenna modules. The first column of the codebook is the beam ID. The other notable columns are “Amplitude” and “Phase” columns which are the excitation amplitude and phase for each antenna element. Each beam has a “Paired_with” beam for concurrent MIMO streams. The last column is the index of the beam which is paired with the index shown in the second column. The “Amplitude” is in dBm, and “Phase” is in degrees.



Band	Beam_ID	Module	Ant_Group	Subarray	Ant_Type	Ant_Feed	Amplitude	Phase	Paired_with
260	7	1	0	0	PATCH	14;13	0;0	11.25;56.25	135
260	8	2	0	2	PATCH	9;10	0;0	168.75;0	136
260	9	2	0	2	PATCH	14;13	0;0	146.25;33.75	137
260	10	2	0	2	PATCH	14;13	0;0	146.25;168.75	138
260	11	0	0	4	PATCH	9;10	0;0	67.5;225	139
260	12	0	0	4	PATCH	9;10	0;0	123.75;135	140
260	13	0	0	4	PATCH	10;13	0;0	123.75;157.5	141
260	14	1	0	0	PATCH	14;13	0;0	180;11.25	142
260	15	1	0	0	PATCH	14;13	0;0	11.25;0	143
260	16	2	0	2	PATCH	14;13	0;0	236.25;67.5	144
260	17	2	0	2	PATCH	14;13	0;0	202.5;180	145
260	18	0	0	4	PATCH	13;14	0;0	33.75;0	146
260	19	0	0	4	PATCH	9;10	0;0	270;213.75	147
260	20	1	0	0	PATCH	14;13;9;10	0;0;0;0	101.25;225;180;0	148
260	21	1	0	0	PATCH	14;13;9;10	0;0;0;0	258.75;78.75;123.75;0	149
260	22	1	0	0	PATCH	14;13;9;10	0;0;0;0	11.25;270;33.75;0	150

Figure 8. An example version of the antenna codebook.

Averaging the Power Density for MPE:

Spatial averaging is needed to determine the MPE values from the Poynting vector (and power density) simulation results over the 4 cm² area required by the FCC. Figure 9 illustrates how the averaging is conducted in the post-processing.

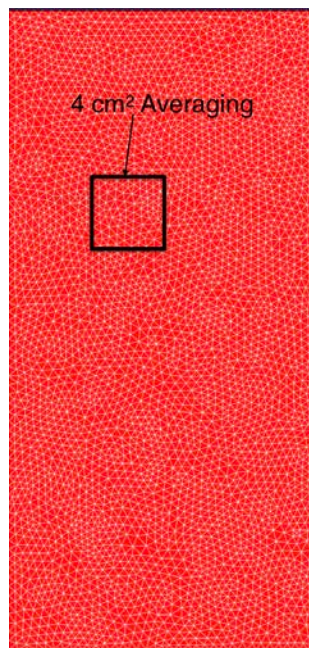

Figure 9. Averaging power density of 4cm² area to get MPE results.



5 Uncertainty Budget for Simulation

Below is a table summarizing the budget of the uncertainty contributions of the numerical algorithm and of the rendering of the simulation setup. The table was filled using the IEC 62704-4 ED1.

Table 2 – Preliminary budget of the uncertainty contributions of the numerical algorithm.

Uncertainty component	Subclause	Probability distribution	Divisor $f(d, h)^1$	C_i^2	Uncertainty %
Mesh resolution	5.1	Normal	1	1	0.6%
ABC	5.2	Normal	1	1	0.8%
Power budget	5.3	Normal	1	1	0.01%
Convergence	5.5	Rectangular	1,73	1	0.2%
DUT dielectrics	5.6	Normal	1	1	3.9%
Lossy conductors	5.7	Rectangular	1,73	1	1.2%
Combined standard uncertainty ($k = 1$)					6.71 %

Note 1: The divisor is a function of the probability distribution and degrees of freedom (ν_i and ν_{eff}).

Note 2: c_i is the sensitivity coefficient that is applied to convert the variability of the uncertainty component into a variability of psPD.

6 Simulation versus Measurement

To validate the accuracy of the model, measured paired beam EIRP values for the three modules were compared to the simulated EIRP for different paired beams at n261 band. In the entire report, the evaluation versus measurement is performed at middle channel and excitation power per array element at n261 band is 12 dBm and at n260 band, it is 11 dBm. The comparison is shown in Table 3, 4, 5. The third column presents the delta between the simulation and measurement results. Looking at the tables, one can see that the correlation between the simulation and measurement results are reasonable.



Table 3: EIRP comparison between simulation and measurement for “Top Module”.

Paired Beams	EIRP, Simulation (dBm)	EIRP, Measurement (dBm)	Delta, Sim-Meas. (dB)
166,38	25.8	26.6	-0.8
152,24	25.7	26.7	-1
153,25	25.25	26.02	-0.77

Table 4: EIRP comparison between simulation and measurement for “Bottom Module”.

Paired Beams	EIRP, Simulation (dBm)	EIRP, Measurement (dBm)	Delta, Sim-Meas. (dB)
169,41	26	26.7	-0.7
157,29	26	25.8	-0.2
156,28	25.3	26.5	-1.2

Table 5: EIRP comparison between simulation and measurement for “Front Module”.

Paired Beams	EIRP, Simulation (dBm)	EIRP, Measurement (dBm)	Delta, Sim-Meas. (dB)
172,44	27.91	29.4	-1.49
161,33	27.7	29.6	-1.9
160,32	27.7	28.9	-1.2

To validate model’s accuracy for MPE calculations, the simulated and measured field distributions for some selected beams from n261 band are shown in Figs. 10-12, below. The measurement data was collected and provided. There is a reasonable agreement between the simulation and measurement results. All plots are normalized to their own maximum and plotted in dB scale. Please note that for top and bottom arrays, S3 and S4 power density values are very small compared to the other presented surfaces. Also, S2, for the front array, has a very small value compared to the other surfaces.

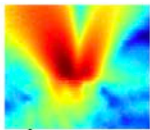
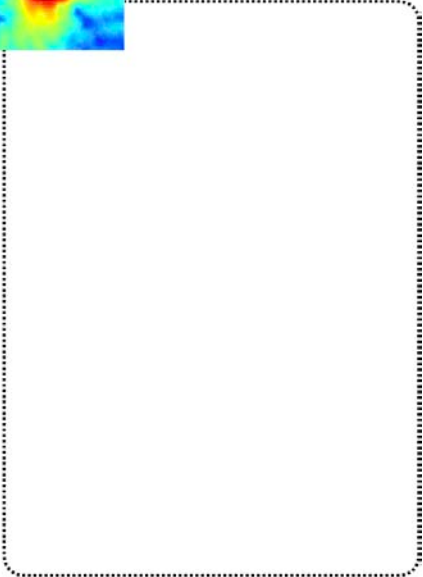
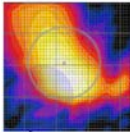
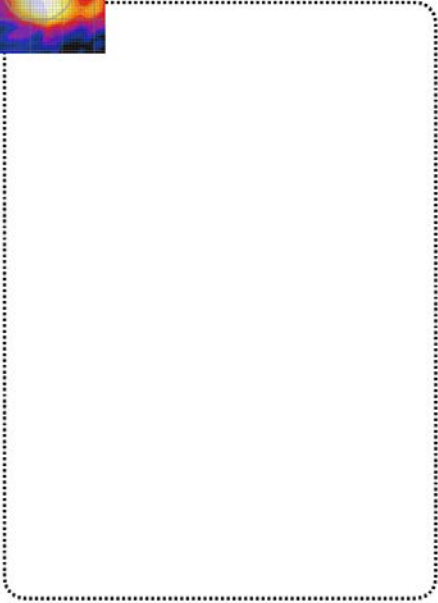
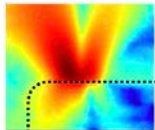
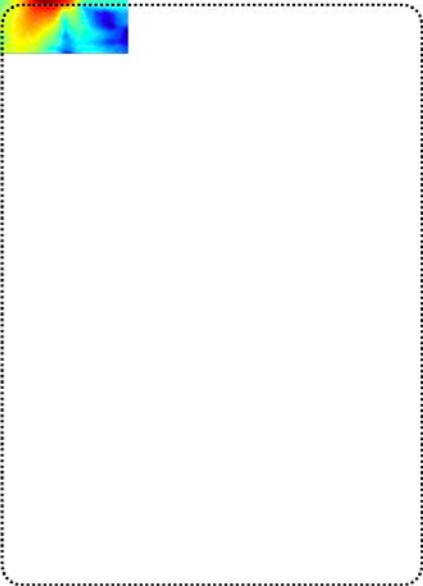
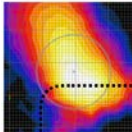
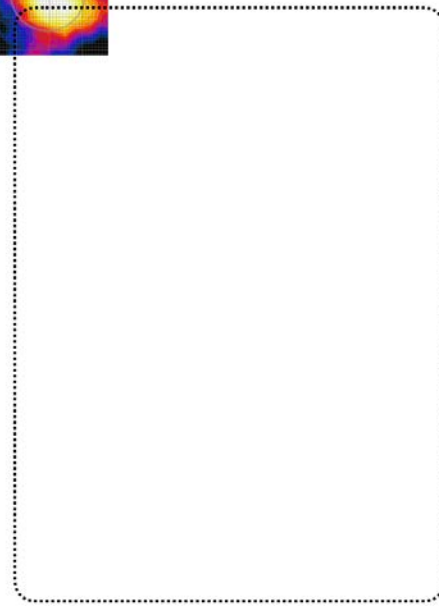

Beam ID	Surface	Measured Power Density	Simulated Power Density
150	S1	 	 
	S2	 	 

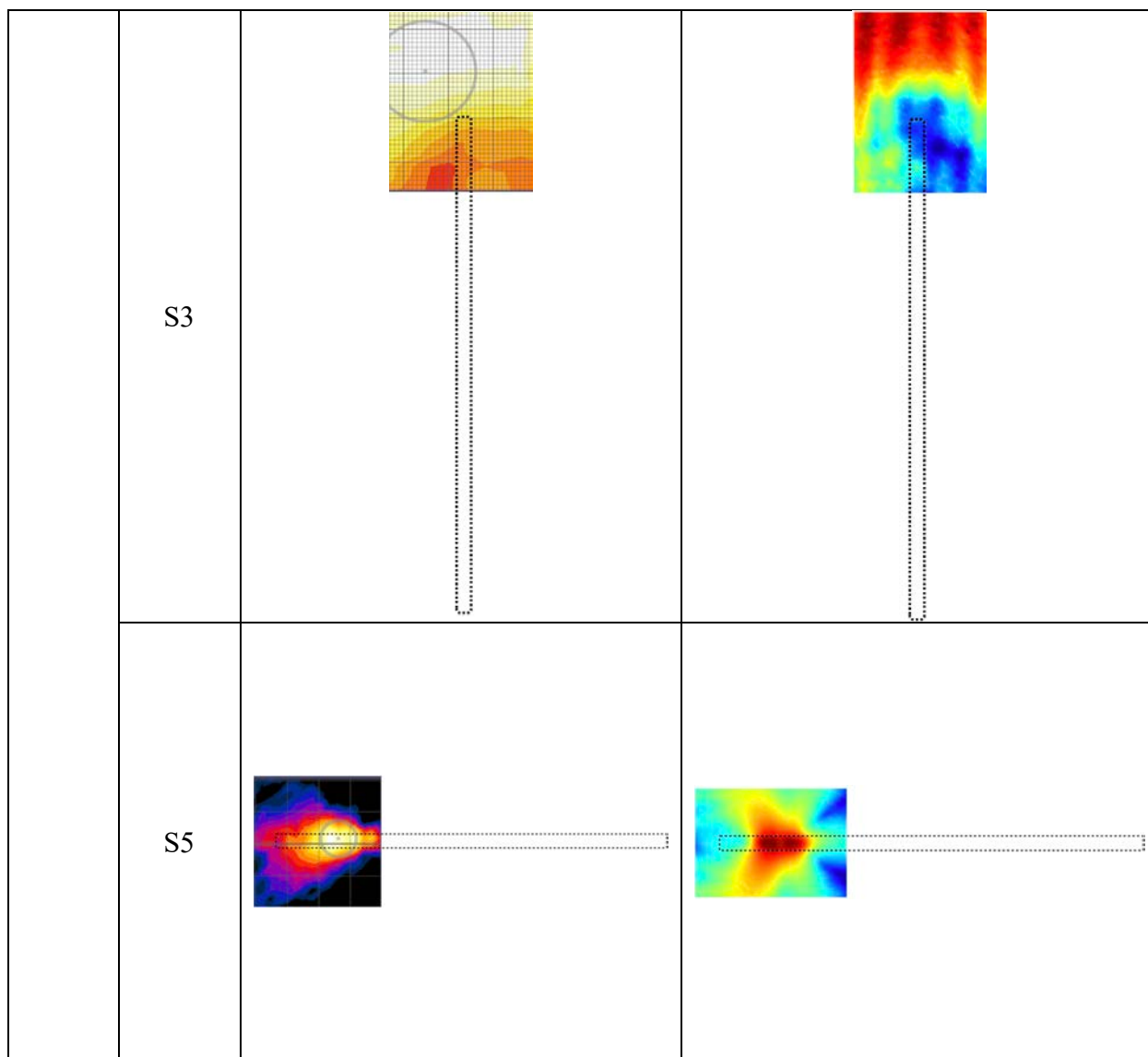
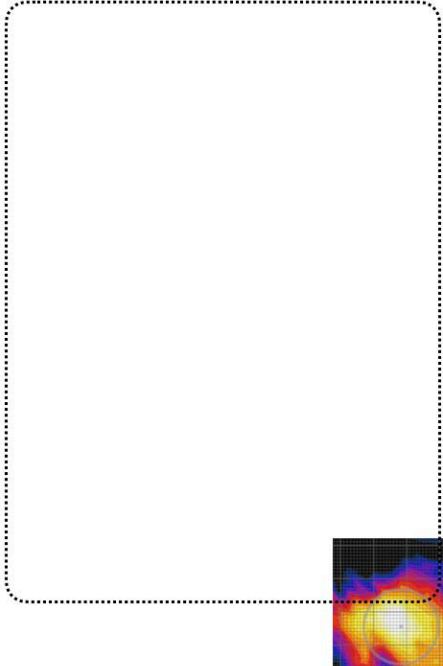
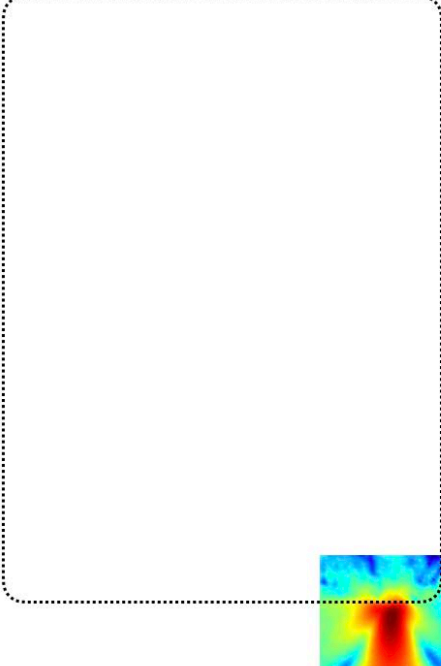
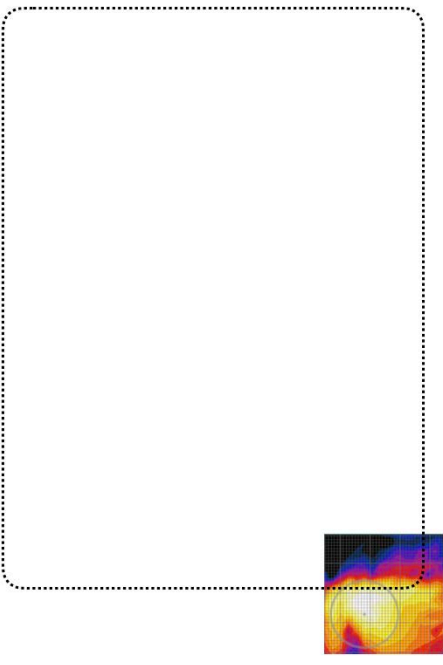
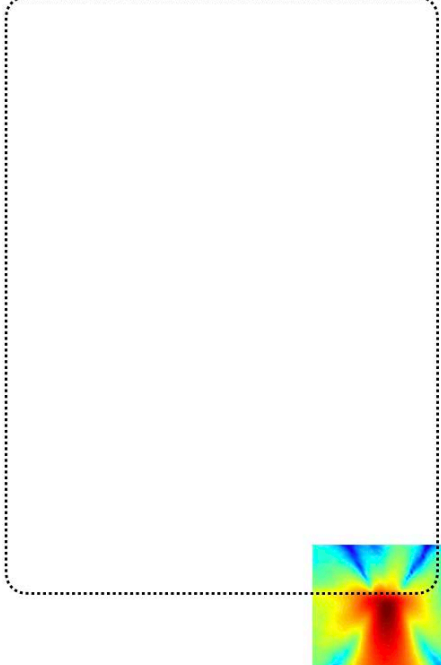

Figure 10. Top array: simulated and measured power density at 2 mm away from DUT. Measured max MPE from measurement is 6.28 mW/cm², and from simulation is 7.91 mW/cm² (scale: dB)



Beam ID	Surface	Measured Power Density	Simulated Power Density
158	S1		
	S2		

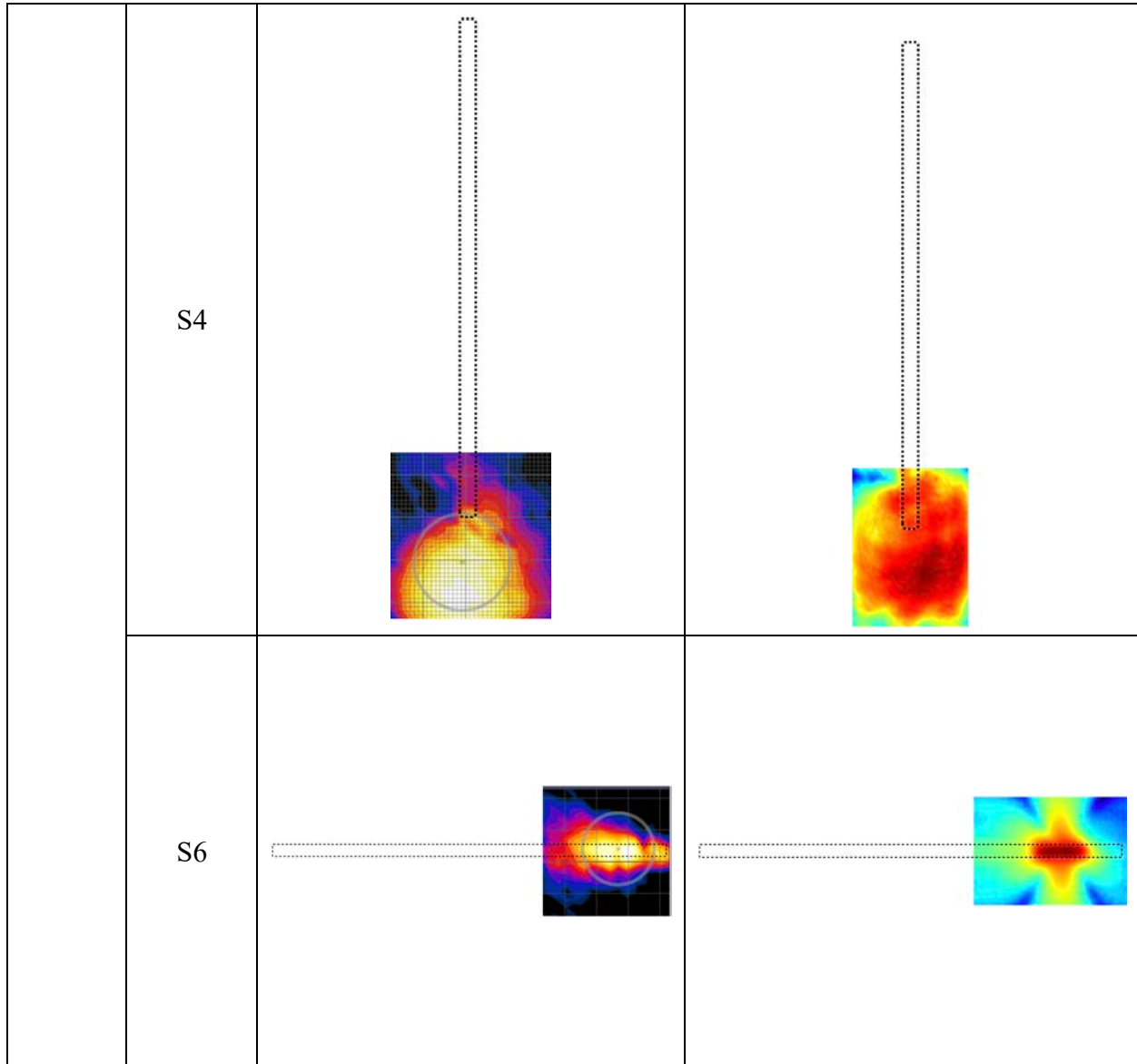
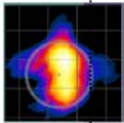
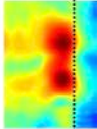
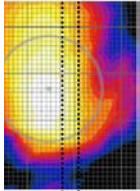
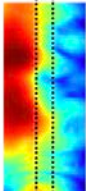

Figure 11. Bottom array: simulated and measured power density at 2 mm away from DUT. Measured max MPE for measurement is 5.63 mW/cm², and simulation is 8.17 mW/cm² (scale: dB).



Beam ID	Surface	Measured Power Density	Simulated Power Density
44	S1		
	S4		

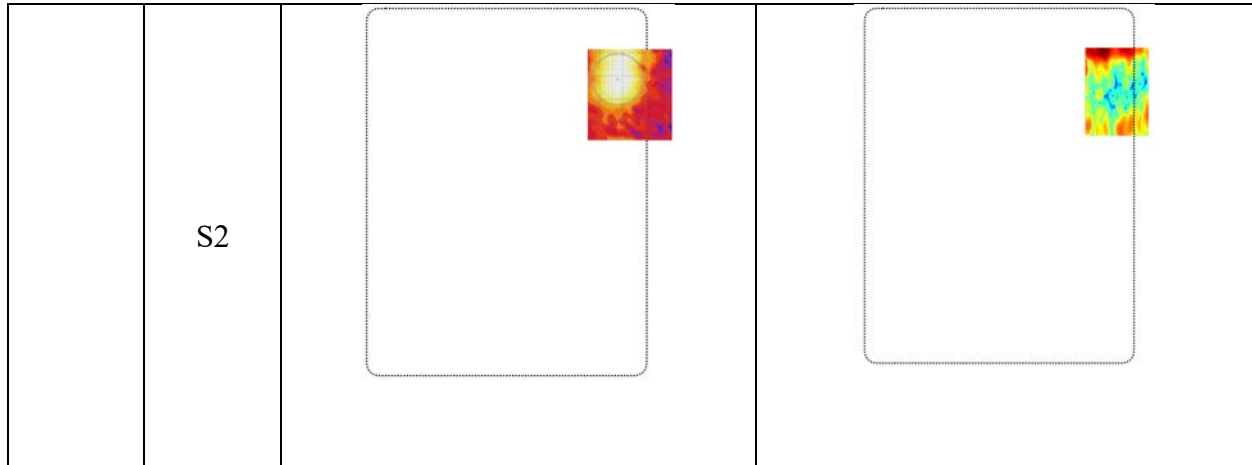

Figure 12. Front array: simulated and measured power density at 2 mm away from DUT. Measured max MPE for measurement is 6.45 mW/cm², and simulation is 4.12 mW/cm² (scale: dB).

In addition, measured and simulated MPE values for some selected beams are summarized below in Tables 6-8.



Table 6: MPE from simulation and measurement for “Top Module” at n261.

Beam ID	Simulation (dBmW/cm ²)	Measurement (dBmW/cm ²)	Delta = Sim-Meas (dB)
23	10.4	8.17	2.18
24	10.46	7.27	3.19
37	10.55	7.24	3.31
38	10.46	7.8	2.66
150	8.98	7.98	1

Table 7: MPE from simulation and measurement for “Bottom Module” at n261.

Beam ID	Simulation (dBmW/cm ²)	Measurement (dBmW/cm ²)	Delta = Sim-Meas (dB)
27	10.47	8.61	1.86
28	10.35	7.89	2.46
29	10.44	8.56	1.88
40	10.52	7.92	2.6
158	9.12	7.51	1.61

Table 8: MPE from simulation and measurement for “Front Module” at n261.

Beam ID	Simulation (dBmW/cm ²)	Measurement (dBmW/cm ²)	Delta = Sim-Meas (dB)
31	7.9	6.59	1.31
44	6.15	8.1	-1.91
160	7.91	7.75	0.16
161	8.43	7.63	0.8
172	8.64	8.1	0.59

Looking at the delta between the simulation and measurement, there is a good correlation between the simulation and measurement data for most of the beams. For a small portion of the beams the delta between the simulation and measurement is slightly higher but still within a reasonable margin. This delta is related to the measurement and simulation uncertainties. For example, we suspect that the unavoidable coupling between the E-field probe and antenna when conducting measurements, can play a role. To characterize the effect of measurement probe coupling, simulations and measurements at increasing distances from the DUT were compared. As is shown in Fig. 13, as the distance increases from 2 mm to 25 mm, the probe coupling effect decreases and the measurement results converge with the simulation results.

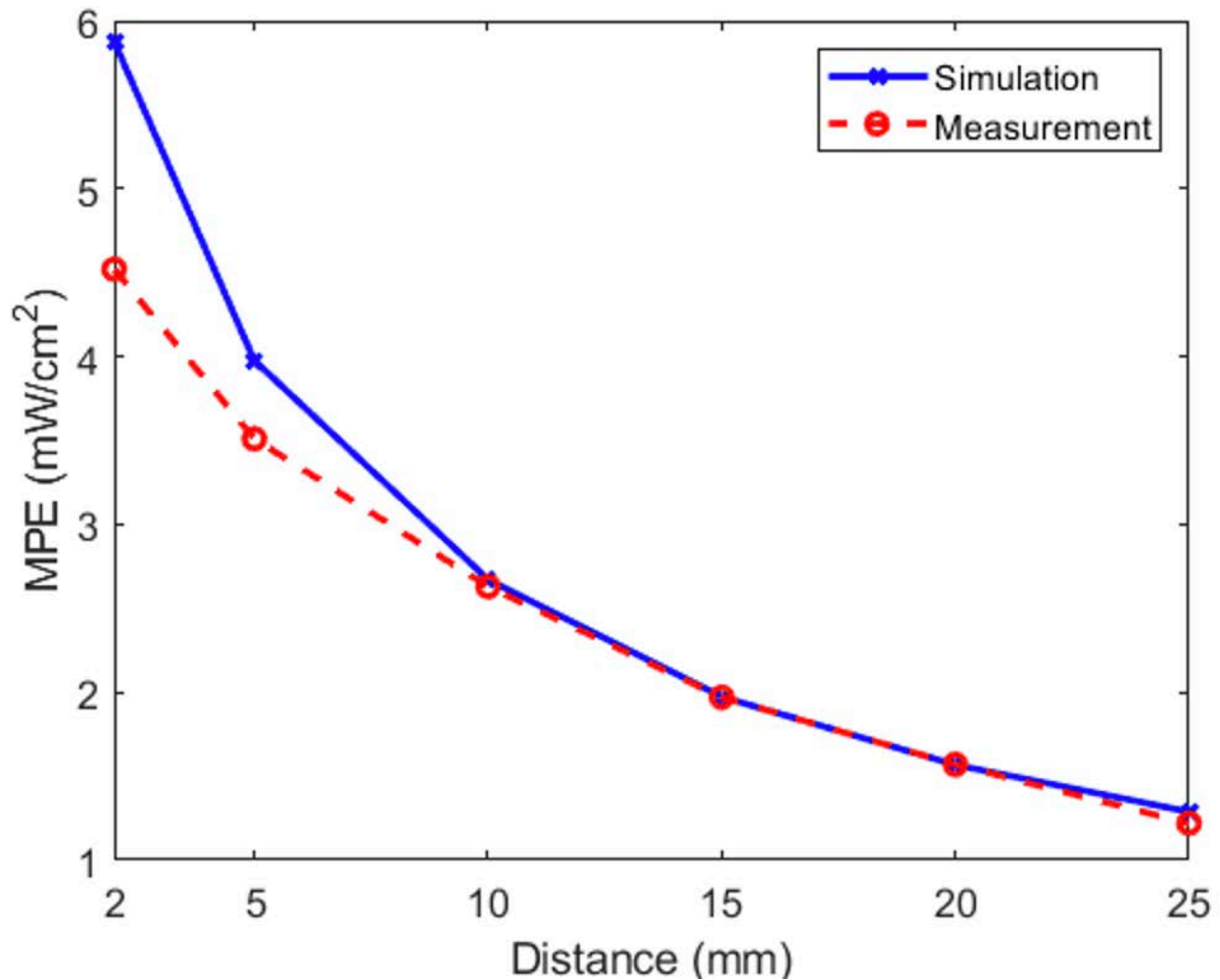
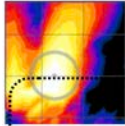
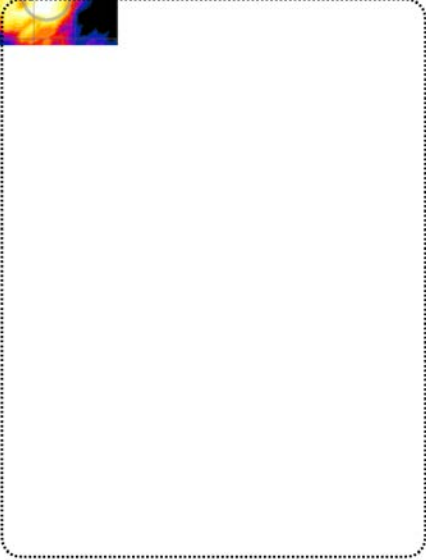
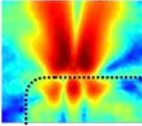
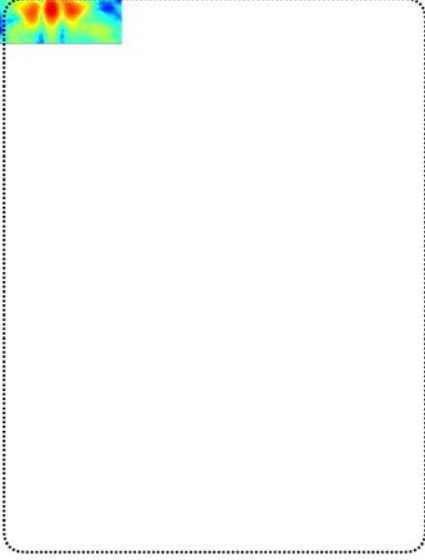
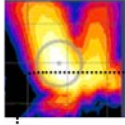
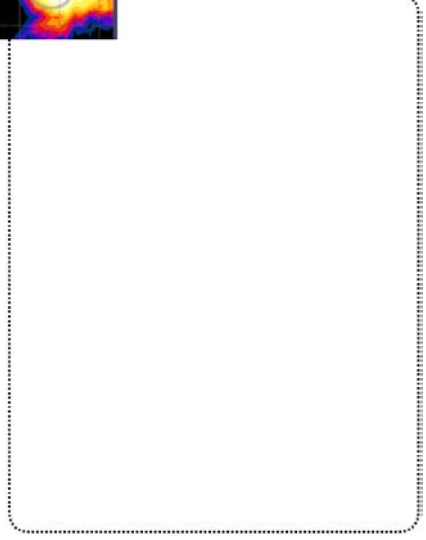
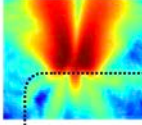
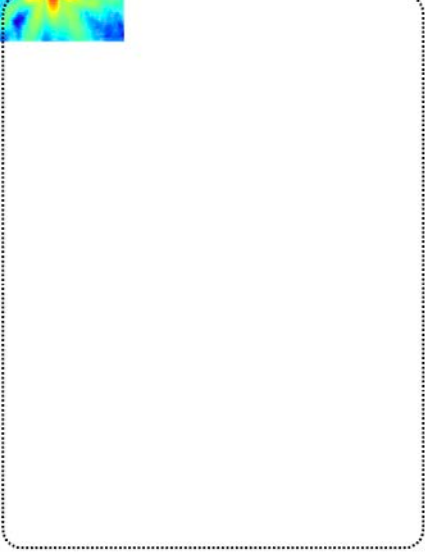

Figure 13. Simulation and measurement comparison with increasing distance from DUT, Front Module at n261, Beam 31.

For n260 band, some selected beams are shown in Figs. 14-16, below. The measurement data was collected and provided. There is a reasonable agreement between the simulation and measurement results. All plots are normalized to their own maximum and plotted in dB scale. Similar to n261 band, please note that for top and bottom arrays, S3 and S4 power density values are very small compared to the other presented surfaces. Also, S2, for the front array, has a very small value compared to the other surfaces.



Beam ID	Surface	Measured Power Density	Simulated Power Density
153	S1	 	 
	S2	 	 

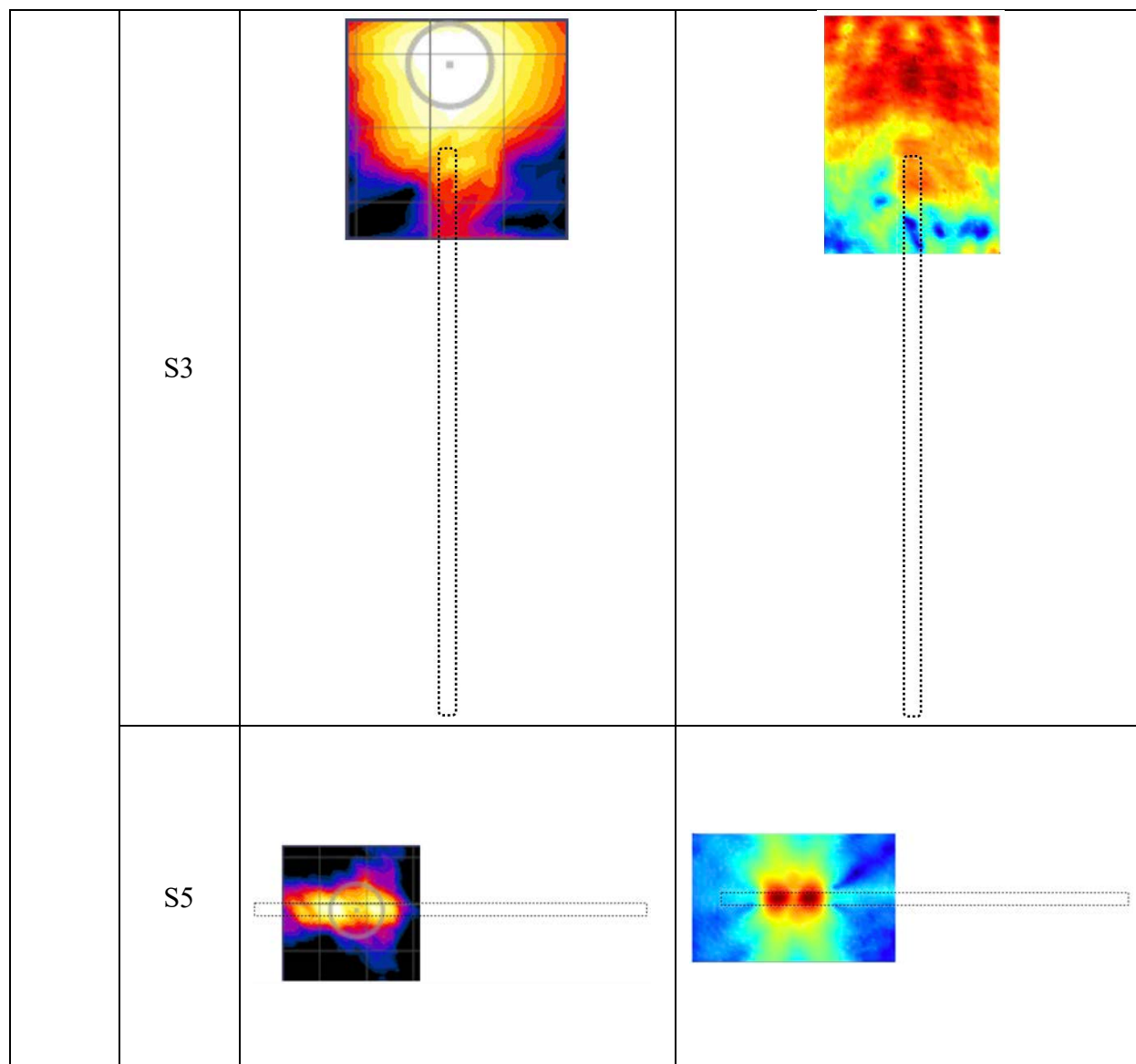
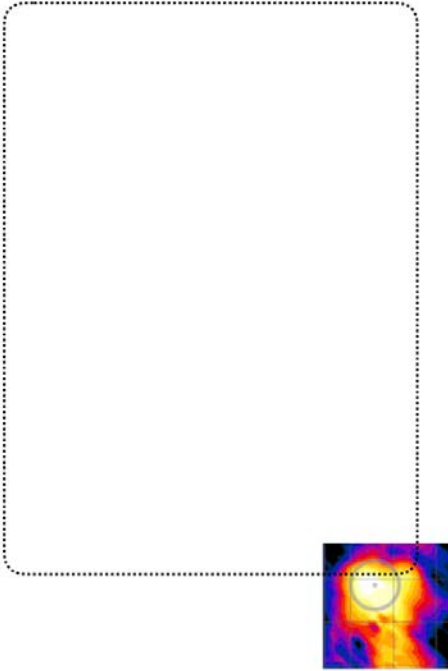
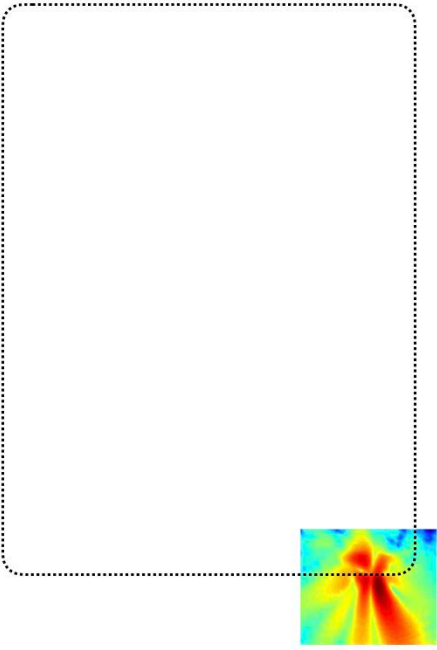
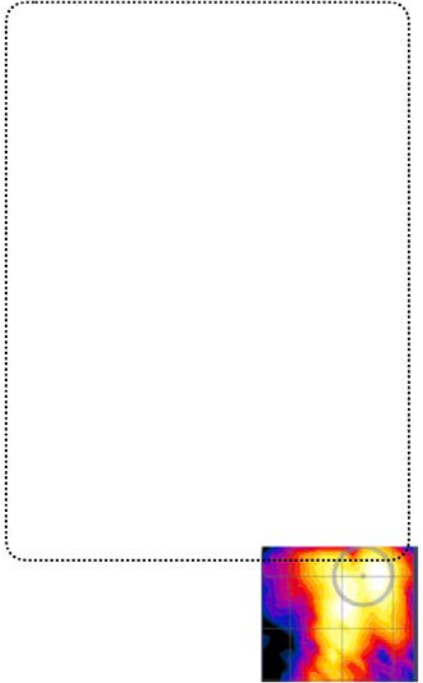
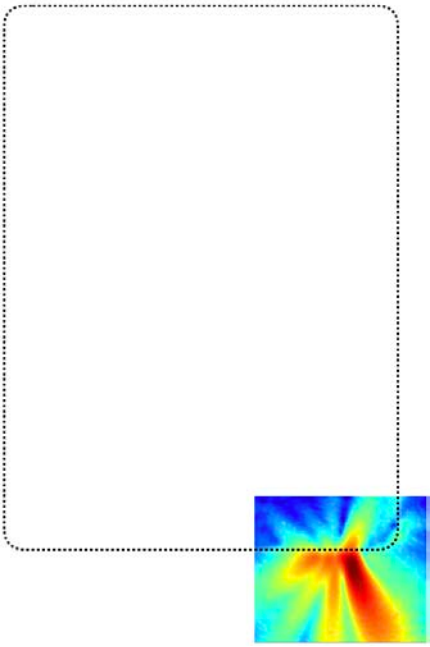

Figure 14. Top array: simulated and measured power density at 2 mm away from DUT. Measured max MPE from measurement is 6.59 mW/cm², and from simulation is 7.4 mW/cm² (scale: dB)



Beam ID	Surface	Measured Power Density	Simulated Power Density
29	S1		
	S2		

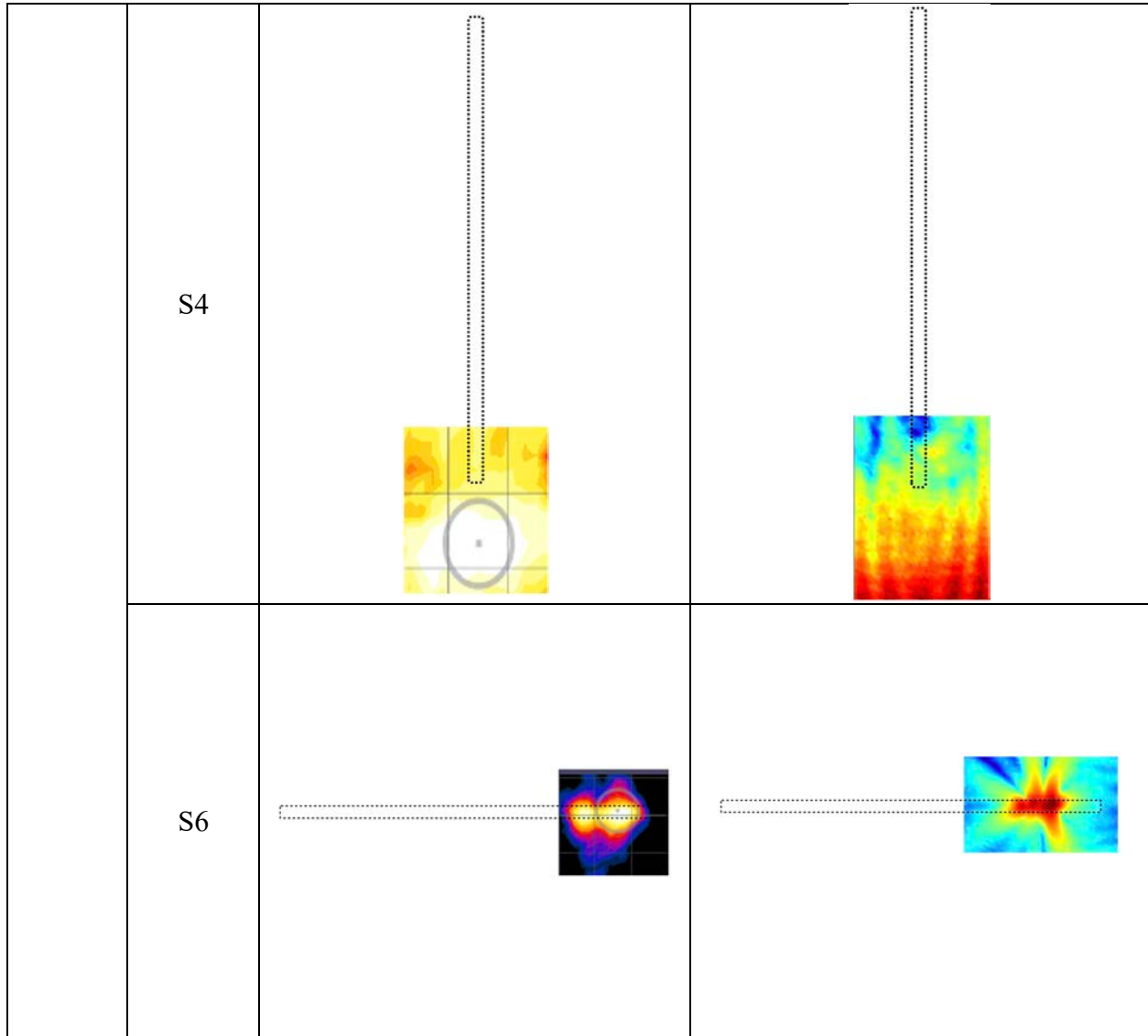

Figure 15. Bottom array: simulated and measured power density at 2 mm away from DUT. Measured max MPE for measurement is 4.56 mW/cm², and simulation is 5.5 mW/cm² (scale: dB).



Beam ID	Surface	Measured Power Density	Simulated Power Density
44	S1		
	S4		
	S2		

Figure 16. Front array: simulated and measured power density at 2 mm away from DUT. Measured max MPE for measurement is 3.31 mW/cm², and simulation is 3.97 mW/cm² (scale: dB).



In addition, measured and simulated MPE values for some selected beams at n260 are summarized below in Tables 9-11.

Table 9: MPE from simulation and measurement for “Top Module” at n260.

Beam ID	Simulation (dBmW/cm ²)	Measurement (dBmW/cm ²)	Delta = Sim-Meas (dB)
39	8.08	6.88	1.2
151	7.56	7.16	0.4
153	7.4	6.59	0.81
166	7.56	7.38	0.18
167	7.71	7.3	0.41

Table 10: MPE from simulation and measurement for “Bottom Module” at n260.

Beam ID	Simulation (dBmW/cm ²)	Measurement (dBmW/cm ²)	Delta = Sim-Meas (dB)
29	7.47	7.08	0.39
30	7.64	5.59	2.05
156	7.5	7.68	-0.2
158	7.75	6.82	0.93
170	7.65	7.3	0.35

Table 11: MPE from simulation and measurement for “Front Module” at n260.

Beam ID	Simulation (dBmW/cm ²)	Measurement (dBmW/cm ²)	Delta =Sim-Meas (dB)
31	6.97	4.1	2.87
44	5.93	5.19	0.74
161	6.76	7.14	-0.38
173	6.73	6.53	0.2
174	6.77	6.65	0.12



Appendix A: Worst Phase Derivation for Beam Pair

For beam pairs, since the relative phase between two beams is unknown, so finding the worst-case power density by sweeping the relative phase for all possible angles is required for conservative assessments.

Assuming E-field and H-field for beam ID a are $\{E_{x_a}, E_{y_a}, E_{z_a}\}$ and $\{H_{x_a}, H_{y_a}, H_{z_a}\}$, respectively; for beam pair which is ID b is $\{E_{x_b}, E_{y_b}, E_{z_b}\}$ and $\{H_{x_b}, H_{y_b}, H_{z_b}\}$, respectively. The relative phase between beam a and b is θ , the combined E and H field after beam pairing is:

$$E_{x_pair_i}(\theta) = E_{x_a} + E_{x_b} \times e^{-j\omega\theta}$$

$$E_{y_pair_i}(\theta) = E_{y_a} + E_{y_b} \times e^{-j\omega\theta}$$

$$E_{z_pair_i}(\theta) = E_{z_a} + E_{z_b} \times e^{-j\omega\theta}$$

$$H_{x_pair_i}(\theta) = H_{x_a} + H_{x_b} \times e^{-j\omega\theta}$$

$$H_{y_pair_i}(\theta) = H_{y_a} + H_{y_b} \times e^{-j\omega\theta}$$

$$H_{z_pair_i}(\theta) = H_{z_a} + H_{z_b} \times e^{-j\omega\theta}$$

The beam pair Poynting vector can be calculated as:

$$S_{x_pair_i}(\theta) = 0.5 \times E_{y_pair_i}(\theta) \times H_{z_pair_i}(\theta)^* - 0.5 \times E_{z_pair_i}(\theta) \times H_{y_pair_i}(\theta)^*$$

$$S_{y_pair_i}(\theta) = 0.5 \times E_{z_pair_i}(\theta) \times H_{x_pair_i}(\theta)^* - 0.5 \times E_{x_pair_i}(\theta) \times H_{z_pair_i}(\theta)^*$$

$$S_{z_pair_i}(\theta) = 0.5 \times E_{x_pair_i}(\theta) \times H_{y_pair_i}(\theta)^* - 0.5 \times E_{y_pair_i}(\theta) \times H_{x_pair_i}(\theta)^*$$

The local power density per gird point (PD) for the beam pair can be calculated as:

$$PD(\theta) = [\text{Re}(S_{x_pair_i}(\theta))]^2 + (\text{Re}(S_{y_pair_i}(\theta)))^2 + (\text{Re}(S_{z_pair_i}(\theta)))^2]^{1/2}$$

One can sweep θ from 0 to 360 degrees to find the worst-case situation (highest PD).



Appendix B: 4 cm² Averaged PD and Scaling Factor

4 cm² Averaged PD: The following tables show the simulated averaged PD over 4cm² area (i.e., psPD) results for all three different modules, at both band n261 and band n260. The data is provided for single polarization and paired beams.



Data for Single Polarization Beams:

a) Simulated psPD (mW/cm^2) with 4 cm^2 averaging for top module at n261

Module	Channel	LB				MB				HB			
Top Module, n261	BeamID	S1	S2	S3	S5	S1	S2	S3	S5	S1	S2	S3	S5
	0	0.96	1.04	0.08	2.85	0.91	0.98	0.07	2.78	0.91	1	0.08	2.88
	1	0.92	0.99	0.08	2.83	0.87	0.95	0.1	2.78	0.86	0.93	0.1	2.81
	6	2.36	2.15	0.32	5.57	2.41	2.13	0.3	5.54	2.42	2.14	0.31	5.61
	7	2.26	2.58	0.02	6.75	2.19	2.53	0.04	6.69	2.02	2.33	0.06	6.35
	8	2.1	2.29	0.06	5.23	2.13	2.27	0.05	5.22	2.08	2.19	0.03	5.05
	15	2.7	2.72	0.14	6.61	2.62	2.62	0.12	6.33	2.41	2.42	0.11	5.77
	16	1.49	1.79	0.14	5.24	1.49	1.87	0.19	5.5	1.54	1.83	0.24	5.85
	21	3.14	2.66	0.72	7.81	3.62	3	0.79	8.74	4.06	3.37	0.94	9.78
	22	4.89	4.68	0.33	11.04	4.63	4.22	0.32	10.61	4.34	3.88	0.27	10.09
	23	4.24	4.51	0.23	11.25	4.31	4.75	0.24	11.5	4.03	4.51	0.23	11.01
	24	3.92	4.63	0.15	10.75	4.12	4.75	0.21	11.29	4.06	4.62	0.29	11.15
	25	3.02	3.4	0.3	8.44	3.24	3.66	0.34	9.22	3.47	3.93	0.37	9.62
	35	4.64	4.18	0.77	10.81	4.69	4.27	0.8	10.8	4.55	3.96	0.76	10.19
	36	4.55	4.55	0.21	11.21	4.4	4.41	0.29	11.08	4.25	4.3	0.34	10.88
	37	4.22	4.82	0.16	10.99	4.28	4.91	0.15	11.23	4.05	4.52	0.12	10.63
	38	3.37	4.01	0.26	9.28	3.63	4.19	0.33	10.11	3.81	4.41	0.38	10.75
	128	0.83	0.84	0.21	2.8	0.71	0.74	0.18	2.41	0.65	0.7	0.16	2.19
	129	0.94	0.97	0.13	3.13	0.86	0.9	0.12	2.84	0.78	0.84	0.09	2.61
	134	1.93	1.62	0.04	4.91	1.9	1.54	0.04	4.61	1.8	1.47	0.04	4.41
	135	1.47	1.96	0.73	6.15	1.4	1.84	0.67	5.87	1.33	1.78	0.62	5.61
	136	1.47	1.94	0.21	4.96	1.43	1.91	0.22	4.88	1.44	1.87	0.2	4.85
	143	1.77	1.47	0.45	5.71	1.71	1.4	0.41	5.38	1.65	1.36	0.39	5.19
	144	1.68	2.18	0.42	5.44	1.63	2.11	0.39	5.29	1.51	2.02	0.36	5.02
	149	3.5	3.31	0.04	8.24	3.47	3.34	0.04	8.06	3.41	3.42	0.03	7.89
	150	4.21	3.36	0.28	9.37	4.1	3.36	0.25	9.15	3.89	3.29	0.27	8.89
	151	3.53	2.99	1.21	10.28	3.51	3.02	1.1	10.24	3.5	2.96	1.01	10.19
	152	3.47	5.1	1.49	11.55	3.21	4.8	1.41	10.84	3	4.6	1.17	10.18
153	3.36	4.32	0.58	8.61	3.22	4.02	0.5	8.65	3.1	3.75	0.47	8.12	
163	3.81	3.34	0.14	8.27	3.75	3.41	0.11	8.11	3.64	3.38	0.11	7.94	
164	4.89	3.11	0.21	10.97	4.65	3.07	0.2	10.49	4.45	3.53	0.18	10.06	
165	3.08	4.34	2.06	11.14	2.82	4.12	1.9	10.39	2.61	3.99	1.68	9.86	
166	3.43	4.77	0.83	9.2	3.2	4.47	0.79	8.56	3.03	4.2	0.71	7.91	



b) Simulated psPD (mW/cm^2) with 4 cm^2 averaging for bottom module at n261

Module	Channel	LB				MB				HB			
Bottom Module, n261	BeamID	S1	S2	S4	S6	S1	S2	S4	S6	S1	S2	S4	S6
	2	1.04	1.02	0.11	3.04	1.09	1.05	0.1	3.13	1.07	0.99	0.12	3.09
	3	0.92	0.99	0.08	2.83	0.87	0.95	0.1	2.78	0.86	0.93	0.1	2.81
	9	2.36	2.15	0.32	5.57	2.41	2.13	0.3	5.54	2.42	2.14	0.31	5.61
	10	2.38	2.67	0.01	6.86	2.37	2.6	0.02	6.75	2.09	2.38	0.04	6.32
	11	1.38	1.55	0.19	5.14	1.32	1.62	0.26	5.25	1.46	1.61	0.32	5.68
	17	2.7	2.72	0.14	6.61	2.62	2.62	0.12	6.33	2.41	2.42	0.11	5.77
	18	2.1	2.29	0.06	5.23	2.13	2.27	0.05	5.22	2.08	2.19	0.03	5.05
	26	3.47	2.96	0.76	8.44	4.06	3.41	0.83	9.38	4.43	3.73	0.97	10.2
	27	4.74	4.53	0.68	10.95	4.66	4.3	0.68	10.59	4.32	3.76	0.61	10.15
	28	4.18	4.55	0.24	11.01	4.19	4.78	0.24	11.27	4	4.49	0.2	10.77
	29	3.74	4.4	0.21	10.34	4	4.67	0.23	10.76	4.05	4.81	0.32	11.26
	30	2.99	3.39	0.31	8.44	3.23	3.7	0.29	8.95	3.49	4.01	0.33	9.87
	39	4.17	3.63	0.76	9.76	4.46	3.82	0.83	10.24	4.46	3.78	0.87	10.17
	40	4.63	4.55	0.17	11.03	4.44	4.22	0.27	10.67	4.31	4.07	0.34	10.64
	41	3.77	4.51	0.16	10.31	3.98	4.64	0.22	10.85	3.92	4.51	0.31	10.75
	42	3.21	3.72	0.27	8.92	3.46	3.93	0.32	9.78	3.69	4.2	0.36	10.58
	130	0.83	0.88	0.16	2.74	0.9	0.91	0.16	2.89	0.89	0.9	0.15	2.87
	131	0.94	0.97	0.13	3.13	0.86	0.9	0.12	2.84	0.78	0.84	0.09	2.61
	137	1.95	1.59	0.07	5.02	1.85	1.51	0.07	4.7	1.75	1.44	0.07	4.5
	138	1.4	1.87	0.73	6.04	1.21	1.75	0.66	5.49	1.17	1.69	0.61	5.31
	139	1.73	1.95	0.24	4.89	1.68	1.89	0.21	4.72	1.59	1.8	0.18	4.46
	145	1.77	1.47	0.45	5.71	1.71	1.4	0.41	5.38	1.65	1.36	0.39	5.19
	146	1.36	1.97	0.31	5.32	1.37	1.94	0.31	5.24	1.39	1.92	0.29	5.24
	154	3.4	3.3	0.06	8.27	3.35	3.32	0.05	8.06	3.29	3.26	0.03	7.89
	155	3.6	3.3	0.36	9.49	3.56	3.31	0.34	9.28	3.38	3.24	0.34	9.04
	156	4.01	3.35	0.79	10.68	4.04	3.3	0.74	10.39	3.94	3.23	0.67	10.15
	157	3.52	5.12	1.29	11.33	3.34	4.88	1.18	10.59	3.11	4.67	1.12	9.92
158	3.36	4.32	0.58	8.61	3.22	4.02	0.5	8.65	3.1	3.75	0.47	8.12	
167	3.71	3.3	0.23	8.34	3.77	3.36	0.18	8.17	3.63	3.32	0.19	7.99	
168	4.84	3.75	0.19	10.89	4.73	3.58	0.19	10.4	4.42	3.46	0.2	9.96	
169	2.18	2.84	1.75	8.87	2.55	2.72	1.61	9.34	2.65	2.67	1.51	9.39	
170	3.38	4.62	0.69	9.43	3.21	4.32	0.66	8.74	3.03	4.05	0.62	8.65	



c) Simulated psPD (mW/cm^2) with 4 cm^2 averaging for front module at n261

Module	Channel	LB			MB			HB		
Front Array, n261	BeamID	S1	S2	S4	S1	S2	S4	S1	S2	S4
	4	1.62	0.03	0.28	2	0.02	0.4	2.49	0.02	0.48
	5	1.43	0.03	0.29	2	0.04	0.46	2.41	0.04	0.56
	12	3.57	0.08	0.8	4.21	0.06	0.91	4.95	0.06	1.07
	13	3.81	0.08	0.66	3.81	0.06	0.68	4.26	0.06	0.73
	14	3.59	0.05	0.45	3.36	0.04	0.45	3.62	0.04	0.51
	19	3.66	0.09	0.74	3.86	0.07	0.78	4.36	0.07	0.83
	20	3.79	0.06	0.49	3.5	0.03	0.55	3.87	0.04	0.64
	31	5.07	0.1	1.17	6.24	0.14	1.35	7.6	0.17	1.6
	32	5.02	0.14	1.2	5.93	0.1	1.18	6.85	0.1	1.25
	33	4.98	0.1	0.92	4.28	0.09	0.97	4.57	0.1	1.07
	34	4.25	0.1	0.78	5.28	0.08	1.27	6.4	0.11	1.47
	43	5.14	0.14	1.2	6.13	0.15	1.27	7.39	0.18	1.46
	44	4.47	0.12	1.02	4.39	0.1	1.18	6.02	0.09	1.08
	45	5.21	0.12	0.86	4.79	0.08	1.06	5.58	0.1	1.36
	132	1.95	0.04	0.45	2.4	0.04	0.55	2.32	0.03	0.51
	133	1.4	0.03	0.26	1.63	0.03	0.33	1.89	0.03	0.37
	140	2.98	0.05	0.5	4.06	0.07	0.71	4.63	0.07	0.7
	141	3.76	0.07	0.6	4.77	0.07	0.81	4.71	0.07	0.84
	142	2.87	0.06	0.52	3.29	0.05	0.66	3.76	0.05	0.76
	147	3.47	0.05	0.5	4.61	0.07	0.75	4.78	0.08	0.76
	148	3.72	0.08	0.71	4.5	0.09	0.88	4.34	0.09	0.86
	159	5.29	0.12	1.41	5.77	0.12	1.49	6.5	0.13	1.18
	160	5.07	0.08	0.95	6.73	0.09	1.18	7.36	0.1	1.44
161	5.57	0.09	0.84	6.92	0.09	1.27	7.19	0.13	1.42	
162	4.67	0.18	1.08	5.17	0.17	1.18	5.28	0.14	1.2	
171	5.26	0.09	1.13	6.41	0.13	1.33	6.89	0.13	1.52	
172	5.95	0.1	0.82	7.18	0.11	1.19	7.74	0.09	1.39	
173	4.93	0.15	0.87	5.91	0.16	1.17	6.09	0.15	1.27	



d) Simulated psPD (mW/cm^2) with 4 cm^2 averaging for top module at n260

Module	Channel	LB				MB				HB			
Top Module, n260	BeamID	S1	S2	S3	S5	S1	S2	S3	S5	S1	S2	S3	S5
	0	0.62	0.65	0.05	1.74	0.48	0.69	0.04	1.45	0.26	0.73	0.05	1.39
	1	0.51	0.58	0.04	1.51	0.33	0.53	0.04	1.18	0.17	0.57	0.02	0.98
	6	1.13	1.01	0.2	3.18	1.16	1.06	0.09	2.98	1.27	0.84	0.17	2.65
	7	1.33	0.97	0.12	3.31	1.4	1.14	0.14	3.31	1.36	0.7	0.12	2.83
	8	1.04	0.87	0.08	2.92	1.26	0.76	0.15	2.83	0.88	0.61	0.06	1.93
	15	1.21	0.75	0.2	3.2	1.24	0.88	0.14	2.94	1.27	0.62	0.17	2.54
	16	1.41	1.17	0.1	3.41	1.53	1.35	0.13	3.52	1.44	0.86	0.09	3.09
	21	3.06	3.11	0.08	6.34	3.25	2.97	0.09	5.99	2.11	2.54	0.16	5.08
	22	2.12	1.9	0.26	5.64	2.18	1.97	0.17	5.52	1.78	1.09	0.42	3.46
	23	1.55	0.99	0.32	4.01	1.61	1.28	0.31	3.35	1.81	1.3	0.23	3.32
	24	1.6	1.49	0.27	4.06	2.76	2.22	0.37	5.44	1.88	1.15	0.1	3.49
	25	2.66	2.46	0.13	5.47	3.13	2.5	0.14	5.77	2.68	2.09	0.17	4.9
	36	2.74	2.73	0.16	6.36	2.65	2.45	0.08	5.66	1.63	2.13	0.22	3.8
	37	1.6	1.35	0.33	4.12	1.72	1.74	0.26	4.12	1.8	0.91	0.4	3.31
	38	1.44	1.18	0.26	3.59	2.13	1.4	0.4	4.12	1.69	1.25	0.13	3.21
	39	1.97	1.89	0.18	3.91	2.99	2.49	0.21	6.41	2.25	1.36	0.15	4.03
	128	0.76	0.75	0.05	2.13	0.65	0.55	0.06	1.66	0.45	0.35	0.06	1.11
	129	0.64	0.71	0.05	2	0.78	0.56	0.05	1.81	0.51	0.31	0.04	1.1
	134	1.1	0.98	0.2	3.85	0.69	0.88	0.18	2.76	0.81	0.82	0.1	2.03
	135	1.39	1.45	0.13	3.73	1.34	1.2	0.16	3.19	0.85	0.87	0.1	2.25
	136	1.65	1.87	0.04	4.28	1.65	1.59	0.03	3.91	1.04	1.04	0.05	2.89
	143	1.3	1.29	0.17	3.63	1.23	1.04	0.2	2.95	0.83	0.78	0.12	2.1
	144	1.44	1.53	0.11	3.78	1.4	1.3	0.14	3.33	0.89	0.9	0.09	2.37
	149	2.71	3.08	0.29	7.64	1.91	2.03	0.25	5.36	1.44	1.56	0.19	3.8
	150	2.67	2.69	0.12	7.59	2.2	1.56	0.28	5	1.49	1.4	0.1	2.91
	151	2.5	2.49	0.34	7.55	2.29	1.73	0.45	5.53	1.49	1.68	0.22	4.41
	152	2.65	2.84	0.36	6.75	2.43	2.41	0.31	5.85	1.31	1.4	0.11	3.93
153	2.38	2.54	0.09	6.65	1.98	1.84	0.13	5.29	1.51	1.5	0.18	3.71	
164	2.59	2.57	0.39	7.7	1.94	1.66	0.29	4.13	1.03	1.64	0.22	3.24	
165	2.6	2.66	0.15	7.72	2.21	1.68	0.33	4.67	1.54	1.61	0.11	3.51	
166	2.17	2.45	0.44	7.33	2.31	2.13	0.39	5.96	1.38	1.44	0.2	4.2	
167	2.63	2.96	0.16	6.68	2.8	2.51	0.13	6.12	1.46	1.64	0.09	3.89	



e) Simulated psPD (mW/cm²) with 4 cm² averaging for bottom module at n260

Module	Channel	LB				MB				HB			
Bottom Module, n260	BeamID	S1	S2	S4	S6	S1	S2	S4	S6	S1	S2	S4	S6
	2	0.74	0.53	0.06	1.73	0.98	0.51	0.05	1.88	1.11	0.24	0.1	1.71
	3	0.51	0.58	0.04	1.51	0.33	0.53	0.04	1.18	0.17	0.57	0.02	0.98
	9	1.2	1.13	0.18	3.24	1.28	1.12	0.08	3.07	1.29	0.98	0.15	2.87
	10	1.33	0.97	0.12	3.31	1.4	1.14	0.14	3.31	1.36	0.7	0.12	2.83
	11	1.08	0.86	0.07	2.95	1.3	0.8	0.14	2.88	0.89	0.63	0.06	2.02
	17	1.2	0.75	0.21	3.21	1.17	0.88	0.13	2.91	1.24	0.64	0.18	2.53
	18	1.47	1.23	0.08	3.45	1.56	1.42	0.12	3.57	1.46	0.91	0.09	3.17
	26	3.02	3.24	0.13	6.37	3.04	2.95	0.09	5.76	2.04	2.5	0.15	5.16
	27	2.28	2.24	0.22	5.58	2.3	2.23	0.13	5.49	1.7	1.34	0.38	3.63
	28	1.71	1.16	0.32	4.38	1.62	1.46	0.33	3.64	1.85	1.21	0.31	3.57
	29	1.53	1.4	0.27	4.04	2.52	1.87	0.45	5	1.79	1.18	0.09	3.27
	30	2.2	2.05	0.11	4.83	3.1	2.7	0.17	5.73	2.51	1.77	0.18	4.45
	40	2.91	3.08	0.13	6.45	2.7	2.58	0.07	5.72	1.84	2.09	0.13	5.13
	41	1.71	1.58	0.3	5.03	1.82	1.81	0.26	5.34	1.84	0.91	0.43	3.52
	42	1.55	1.2	0.23	3.8	2.15	1.38	0.42	4.18	1.71	1.25	0.14	3.32
	43	1.91	1.73	0.21	3.52	2.95	2.47	0.28	5.69	2.15	1.3	0.13	3.84
	130	0.6	0.66	0.06	1.83	0.56	0.59	0.05	1.57	0.38	0.55	0.01	1.25
	131	0.64	0.71	0.05	2	0.78	0.56	0.05	1.81	0.51	0.31	0.04	1.1
	137	1.27	1.31	0.11	3.83	1.09	1.13	0.09	3.06	0.92	0.96	0.04	2.23
	138	1.37	1.4	0.15	3.71	1.31	1.15	0.18	3.12	0.83	0.85	0.11	2.19
	139	1.64	1.78	0.02	4.27	1.61	1.6	0.02	3.9	1.04	1.05	0.05	2.89
	145	1.3	1.29	0.17	3.63	1.23	1.04	0.2	2.95	0.83	0.78	0.12	2.1
	146	1.42	1.49	0.12	3.74	1.38	1.25	0.16	3.26	0.86	0.88	0.1	2.31
	154	2.56	2.58	0.41	7.55	1.92	1.8	0.29	4.67	1.45	1.84	0.19	4.18
	155	2.69	2.71	0.17	7.68	2.23	1.65	0.26	5	1.45	1.42	0.17	2.88
156	2.6	2.6	0.31	7.67	2.34	1.86	0.41	5.56	1.53	1.67	0.22	4.48	
157	2.47	2.55	0.45	6.67	2.31	2.1	0.4	5.63	1.36	1.45	0.14	4.18	
158	2.71	2.99	0.08	6.64	2.13	2.2	0.09	5.44	0.89	1.46	0.16	3.76	
168	2.65	2.56	0.43	7.55	2.07	1.51	0.3	4.63	1.11	1.47	0.18	2.55	
169	2.66	2.76	0.14	7.88	2.3	1.84	0.32	5.53	1.59	1.61	0.11	4.1	
170	2.24	2.22	0.42	6.97	2.19	1.9	0.4	5.87	1.43	1.57	0.2	4.23	
171	2.53	2.9	0.23	6.64	2.21	2.41	0.18	5.34	1.42	1.39	0.1	3.84	



f) Simulated psPD (mW/cm²) with 4 cm² averaging for front module at n260

Module	Channel	LB			MB			HB		
Front Module, n260	BeamID	S1	S2	S4	S1	S2	S4	S1	S2	S4
	4	1.62	0.01	0.38	1.35	0.02	0.33	1.46	0.01	0.34
	5	1.02	0.03	0.27	1.15	0.02	0.31	1.28	0.01	0.34
	12	2.77	0.04	0.56	2.44	0.02	0.38	2.2	0.03	0.39
	13	2.88	0.04	0.83	2	0.04	0.64	2.82	0.05	0.87
	14	2.67	0.04	0.34	2.85	0.03	0.45	2.72	0.03	0.32
	19	3.16	0.03	0.92	2.06	0.04	0.75	3.02	0.03	0.95
	20	2.38	0.04	0.51	2.35	0.03	0.36	2.17	0.04	0.47
	31	5.07	0.1	1.16	4.2	0.07	0.92	4.11	0.06	0.51
	32	5.18	0.05	1.96	4.03	0.04	1.69	4.23	0.04	1.06
	33	5.06	0.07	1.81	3.9	0.06	1.45	5.7	0.04	1.61
	34	3.8	0.09	0.73	3.53	0.05	0.89	3.64	0.1	1.16
	35	4.13	0.08	0.63	4.04	0.04	0.64	3.78	0.08	0.7
	44	4.98	0.09	1.4	3.88	0.05	1.1	3.73	0.07	0.79
	45	4.92	0.06	1.96	4.38	0.05	1.76	4.36	0.03	1.63
	46	4.47	0.07	1.25	3.41	0.1	1.09	4.91	0.07	1.52
	47	4.01	0.1	0.82	3.87	0.05	0.84	3.66	0.1	0.93
	132	1.42	0.01	0.3	1.21	0.02	0.28	1.24	0.01	0.28
	133	1.73	0.02	0.29	1.18	0.01	0.17	1.06	0.01	0.17
	140	2.37	0.04	0.42	2.31	0.03	0.29	2.41	0.02	0.28
	141	2.17	0.02	0.48	2.04	0.03	0.58	2.12	0.02	0.71
	142	2.89	0.04	0.67	2.34	0.02	0.49	2.74	0.02	0.48
	147	2.13	0.03	0.41	1.93	0.04	0.45	1.87	0.03	0.51
	148	2.56	0.01	0.7	2.19	0.02	0.7	2.56	0.01	0.79
	159	4.43	0.05	0.92	3	0.05	0.67	2.86	0.09	0.89
	160	4.03	0.04	0.9	3.91	0.05	1.07	3.76	0.05	1.21
	161	4.62	0.04	1.15	4.63	0.07	1.19	4.36	0.02	1.28
	162	4.53	0.06	1.1	4.56	0.04	1.05	4.77	0.04	1.02
163	3.72	0.06	0.57	2.8	0.05	0.59	4.41	0.08	0.46	
172	4.71	0.05	0.97	3.38	0.05	0.8	3.34	0.08	1.15	
173	4.42	0.04	1.07	4.59	0.07	1.27	4.43	0.02	1.27	
174	4.56	0.05	1.06	4.59	0.06	1.05	4.6	0.03	1.3	
175	4.22	0.07	0.95	4.7	0.07	0.87	4.52	0.06	0.71	



Data for Paired Beams:

a) Simulated psPD (mW/cm^2) with 4 cm^2 averaging for top module at n261

Module	Channel		LB				MB				HB			
	Beam ID1	Beam ID2	S1	S2	S3	S5	S1	S2	S3	S5	S1	S2	S3	S5
Top Module, n261	0	128	2.17	2.05	0.3	6.25	1.98	1.87	0.27	5.71	1.87	1.87	0.28	5.57
	1	129	2.01	2.04	0.19	6.22	1.83	2.01	0.2	5.87	1.76	2.05	0.2	5.84
	6	134	4.55	4.12	0.39	11.5	4.39	3.98	0.37	10.9	4.24	3.9	0.36	10.5
	7	135	4.58	4.99	0.82	13.3	4.39	4.84	0.75	12.7	4.1	4.55	0.73	12.1
	8	136	3.71	5.07	0.29	11.1	3.74	4.75	0.27	10.6	3.76	4.32	0.24	10.3
	15	143	5.97	4.98	0.53	13.5	5.63	4.84	0.51	12.7	5.19	4.64	0.48	11.7
	16	144	3.18	3.8	0.69	10.2	3.35	3.84	0.63	10	3.37	3.94	0.67	10.6
	21	149	5.81	5.37	0.84	17	6.26	5.61	0.97	17.7	6.58	5.97	1.09	18.1
	22	150	9.48	7.97	0.47	21.7	8.81	7.33	0.47	20.3	8.45	6.66	0.55	19.8
	23	151	7.99	7.51	1.41	22.3	7.65	7.96	1.28	21.5	7.34	7.82	1.18	20.5
	24	152	6.91	9.46	1.84	21.2	6.89	9.03	1.79	19.8	6.89	8.95	1.79	19
	25	153	6.37	8.44	1.19	17.2	6.36	7.99	1.02	16.7	6.29	6.38	0.99	17.1
	35	163	8.22	6.84	0.93	19.7	8.43	6.9	0.95	19.5	8.07	6.52	0.86	18.9
	36	164	10.1	7.93	0.55	24.5	9.41	7.97	0.68	23.2	8.86	7.92	0.74	21.9
	37	165	6.45	8.09	2.18	19.5	6.22	6.89	2.05	19.7	6	6.55	1.95	18.8
	38	166	6.87	9.25	1.48	19.1	6.76	8.77	1.4	18.6	6.65	8.49	1.38	18.4



b) Simulated psPD (mW/cm^2) with 4 cm^2 averaging for bottom module at n261

Module	Channel		LB				MB				HB			
Bottom Module, n261	Beam ID1	Beam ID2	S1	S2	S4	S6	S1	S2	S4	S6	S1	S2	S4	S6
	2	130	2.04	2.23	0.28	6.49	2.11	2.19	0.25	6.29	2.07	2.11	0.27	6.13
	3	131	2.01	2.04	0.19	6.22	1.83	2.01	0.2	5.87	1.76	2.05	0.2	5.84
	9	137	4.71	3.95	0.38	11.5	4.47	3.84	0.36	11	4.32	3.78	0.36	10.6
	10	138	4.97	5.18	0.79	13.5	4.78	5.09	0.73	12.9	4.41	4.71	0.71	12.1
	11	139	3.33	3.79	0.57	9.95	3.51	3.75	0.54	9.92	3.49	3.82	0.6	10.4
	17	145	5.97	4.98	0.53	13.5	5.63	4.84	0.51	12.7	5.19	4.64	0.48	11.7
	18	146	3.85	5.14	0.35	11.6	3.9	4.75	0.32	11.2	3.9	4.63	0.3	11
	26	154	6.29	5.45	0.96	17.7	6.79	5.86	1.04	18.4	7.1	6.13	1.13	18.8
	27	155	8.96	8.14	0.95	21.3	8.78	7.87	0.87	20.7	8.37	7.35	0.8	19.9
	28	156	8.77	8.27	0.99	22.9	8.49	8.73	0.9	22	8.26	8.74	0.84	20.8
	29	157	6.62	9.17	1.83	19.6	6.53	8.16	1.7	18.7	6.39	8.11	1.71	19.4
	30	158	6.14	8.17	1.14	17.2	6.13	7.43	0.96	16.2	6.01	6.44	0.93	17.1
	39	167	7.57	6.11	0.92	19	7.75	6.42	0.96	19.5	7.67	6.45	0.98	19.4
	40	168	9.99	7.81	0.49	23.5	9.41	7.48	0.59	22.2	8.83	7.26	0.68	21.4
41	169	7.12	8.18	1.98	19.7	7.61	8.62	1.93	20.1	7.87	8.66	1.86	20.1	
42	170	6.72	8.78	1.34	18.3	6.54	8.24	1.19	17.9	6.37	7.31	1.18	17.5	



c) Simulated psPD (mW/cm^2) with 4 cm^2 averaging for front module at n261

Module	Channel		LB			MB			HB		
Front Module, n261	Beam ID1	Beam ID2	S1	S2	S4	S1	S2	S4	S1	S2	S4
	4	132	4.71	0.11	1.12	5.09	0.09	1.23	5.65	0.08	1.12
	5	133	3.34	0.1	0.75	4.16	0.1	1.01	4.98	0.09	1.06
	12	140	7.33	0.18	1.49	8.61	0.13	1.72	10.2	0.15	1.81
	13	141	7.9	0.14	1.54	8.57	0.17	1.62	9.46	0.19	1.66
	14	142	4.78	0.11	0.91	5.27	0.09	1.14	5.65	0.09	1.42
	19	147	7.59	0.16	1.69	8.59	0.18	1.85	9.9	0.18	1.89
	20	148	8.1	0.15	1.39	7.94	0.13	1.64	8.89	0.13	1.84
	31	159	10.7	0.23	2.59	13.8	0.31	3.05	17.1	0.38	3.65
	32	160	10.3	0.31	2.67	13.4	0.27	2.86	15.6	0.27	3.05
	33	161	11.9	0.26	2.05	12.8	0.26	2.48	14	0.28	2.63
	34	162	11.6	0.44	2.96	12.4	0.34	2.47	12.8	0.27	2.79
	43	171	10.8	0.29	2.79	14.2	0.37	3.3	17.4	0.42	3.69
	44	172	11.6	0.28	2.21	14.1	0.25	2.77	15.8	0.21	2.99
	45	173	11	0.4	2.3	13	0.37	2.57	12.8	0.33	2.79



d) Simulated psPD (mW/cm^2) with 4 cm^2 averaging for top module at n260

Module	Channel		LB				MB				HB			
Top Module, n260	Beam ID1	Beam ID2	S1	S2	S3	S5	S1	S2	S3	S5	S1	S2	S3	S5
	0	128	1.6	1.55	0.14	4.32	1.41	1.35	0.13	3.58	0.87	1.38	0.14	2.77
	1	129	1.32	1.69	0.11	4.09	1.54	1.28	0.11	3.73	0.78	1.15	0.07	2.17
	6	134	2.83	2.4	0.48	7.7	2.61	2.69	0.43	6.67	2.25	2.35	0.48	5.69
	7	135	3.38	2.7	0.36	7.96	3.25	2.41	0.43	7.01	2.46	1.67	0.3	5.28
	8	136	2.86	3.05	0.14	7.71	3.42	2.85	0.24	7.29	2.42	1.79	0.17	5.37
	15	143	3.01	2.29	0.51	7.8	2.76	1.96	0.47	6.62	2.22	1.88	0.43	5.22
	16	144	3.46	2.86	0.25	8.16	3.45	2.79	0.36	7.38	2.5	1.99	0.24	5.93
	21	149	6.43	6.52	0.43	13.8	6.01	6.84	0.38	12	4.29	5.83	0.54	9.99
	22	150	5.25	5.04	0.59	13.8	4.82	4.78	0.79	11.6	3.59	3.45	0.98	7.63
	23	151	4.59	4	0.8	12.8	4.74	3.57	1.04	9.62	3.61	3.53	0.67	8.47
	24	152	4.93	5.15	0.73	11.3	6.59	4.95	0.91	11.6	3.51	3.26	0.25	8.78
	25	153	6.44	6.27	0.39	12.4	6.42	5.73	0.38	11.8	4.15	3.86	0.63	10.7
	36	164	6.18	5.78	0.66	14.4	5.11	5.44	0.41	12.2	3.89	5.58	0.43	10
	37	165	4.46	4.26	0.75	13	4.48	4.35	0.98	10.8	3.93	3.04	0.93	7.82
	38	166	4.59	4.46	0.78	10.7	5.6	4.03	1.28	10.2	3.27	3.72	0.51	8.74
	39	167	5.32	5.44	0.47	11.8	7.05	5.61	0.49	11.9	4.52	3.3	0.48	9.11



e) Simulated psPD (mW/cm^2) with 4 cm^2 averaging for bottom module at n260

Module	Channel		LB				MB				HB			
	Beam ID1	Beam ID2	S1	S2	S4	S6	S1	S2	S4	S6	S1	S2	S4	S6
Bottom Module, n260	2	130	1.61	1.27	0.16	3.92	1.94	1.46	0.14	3.68	1.9	1.07	0.15	3.2
	3	131	1.32	1.69	0.11	4.09	1.54	1.28	0.11	3.73	0.78	1.15	0.07	2.17
	9	137	2.37	2.33	0.41	5.38	2.37	2.5	0.27	4.66	1.85	2.05	0.26	4.84
	10	138	3.36	2.65	0.39	7.94	3.18	2.35	0.45	6.97	2.48	1.65	0.32	5.19
	11	139	2.96	3.05	0.13	7.74	3.43	2.86	0.21	7.41	2.49	1.77	0.17	5.45
	17	145	2.98	2.3	0.51	7.78	2.69	2	0.46	6.57	2.18	1.94	0.44	5.33
	18	146	3.44	2.89	0.26	8.15	3.4	2.77	0.36	7.33	2.59	2.15	0.22	6.01
	26	154	5.65	6.13	0.61	14	5.6	7.09	0.52	13.4	4.2	6.02	0.52	10.2
	27	155	5.57	5.4	0.5	13.8	5.05	5.21	0.7	11.6	3.32	3.87	0.93	7.94
	28	156	4.78	4.16	0.75	13.6	4.26	4.09	0.96	10.9	3.81	3.28	0.73	8.12
	29	157	4.73	4.64	0.83	10.3	6.27	4.56	1.15	11.1	3.45	3.42	0.32	8.46
	30	158	5.77	5.45	0.37	12	6.62	5.56	0.27	11.3	4.77	3.65	0.67	9.94
	40	168	6.07	6.04	0.74	14.6	5.19	5.63	0.45	12	3.96	5.75	0.38	10.5
	41	169	4.81	4.66	0.7	13.4	4.39	4.67	0.93	12	4	3.09	0.96	8.03
	42	170	4.58	4.08	0.72	12.3	5.44	3.87	1.26	10.2	3.24	3.57	0.55	8.48
	43	171	5.2	5.06	0.57	11.5	6.94	5.29	0.64	11.8	4.23	3.19	0.41	8.85



f) Simulated psPD (mW/cm^2) with 4 cm^2 averaging for front module at n260

Module	Channel		LB			MB			HB		
	BeamID1	BeamID2	S1	S2	S4	S1	S2	S4	S1	S2	S4
Front Module, n260	4	132	3.77	0.03	1.03	2.97	0.04	0.68	3.76	0.03	0.65
	5	133	3.26	0.07	0.77	2.79	0.05	0.68	2.81	0.04	0.69
	12	140	5.92	0.07	1.4	4.8	0.07	0.9	4.65	0.09	0.79
	13	141	5.39	0.08	1.35	4.7	0.09	1.36	5.27	0.06	1.59
	14	142	6.27	0.07	1.3	5.27	0.06	1.06	6.15	0.08	0.99
	19	147	6.01	0.06	1.61	4.95	0.09	1.31	5.44	0.09	1.57
	20	148	5.93	0.06	1.31	5.38	0.08	1.26	5.54	0.07	1.25
	31	159	11.9	0.17	2.94	8.83	0.13	1.83	7.86	0.23	1.57
	32	160	11.5	0.12	3.62	9.88	0.13	2.7	8.44	0.12	2.54
	33	161	12	0.13	3.61	9.47	0.16	2.86	12.3	0.08	3.37
	34	162	11.1	0.2	2.25	9.86	0.15	2.13	11	0.22	2.66
	35	163	9.89	0.17	1.93	9.25	0.13	1.59	8.31	0.26	1.24
	44	172	11.6	0.13	3.38	8.73	0.13	2.25	7.37	0.18	2.03
	45	173	12.2	0.13	4	10.2	0.16	3.16	12	0.08	3.47
	46	174	11.2	0.13	2.65	9	0.17	2.58	12	0.12	3.14
	47	175	11.3	0.24	2.16	9.91	0.16	1.93	10.5	0.28	1.97

Scaling factor calculation: The following tables show the scaling factor results for all three different modules, at both n261 and n260 bands. The scaling factor is defined as the MPE internal design limit (0.6 mW/cm^2) divided by the simulated peak spatial average power density. The data is provided for both single polarization beams and paired beams. In the tables below, the values reported represent the scaled factors for low-band, mid-band and high-band results (S_{LB} , S_{MB} , and S_{HB} , respectively) and the scaling factor SF is the most restrictive of the three band-specific values.



Data for Single Polarization Beams:

a) *Scaling factor for top module n261*

Beam ID	S_LB	S_MB	S_HB	SF
0	0.21	0.22	0.21	0.21
1	0.21	0.22	0.21	0.21
6	0.11	0.11	0.11	0.11
7	0.09	0.09	0.09	0.09
8	0.11	0.11	0.12	0.11
15	0.09	0.09	0.1	0.09
16	0.11	0.11	0.1	0.1
21	0.08	0.07	0.06	0.06
22	0.05	0.06	0.06	0.05
23	0.05	0.05	0.05	0.05
24	0.06	0.05	0.05	0.05
25	0.07	0.07	0.06	0.06
35	0.06	0.06	0.06	0.06
36	0.05	0.05	0.06	0.05
37	0.05	0.05	0.06	0.05
38	0.06	0.06	0.06	0.06
128	0.21	0.25	0.27	0.21
129	0.19	0.21	0.23	0.19
134	0.12	0.13	0.14	0.12
135	0.1	0.1	0.11	0.1
136	0.12	0.12	0.12	0.12
143	0.11	0.11	0.12	0.11
144	0.11	0.11	0.12	0.11
149	0.07	0.07	0.08	0.07
150	0.06	0.07	0.07	0.06
151	0.06	0.06	0.06	0.06
152	0.05	0.06	0.06	0.05
153	0.07	0.07	0.07	0.07
163	0.07	0.07	0.08	0.07
164	0.05	0.06	0.06	0.05
165	0.05	0.06	0.06	0.05
166	0.07	0.07	0.08	0.07



b) Scaling factor for bottom module n261

Beam ID	S_LB	S_MB	S_HB	SF
2	0.2	0.19	0.19	0.19
3	0.21	0.22	0.21	0.21
9	0.11	0.11	0.11	0.11
10	0.09	0.09	0.09	0.09
11	0.12	0.11	0.11	0.11
17	0.09	0.09	0.1	0.09
18	0.11	0.11	0.12	0.11
26	0.07	0.06	0.06	0.06
27	0.05	0.06	0.06	0.05
28	0.05	0.05	0.06	0.05
29	0.06	0.06	0.05	0.05
30	0.07	0.07	0.06	0.06
39	0.06	0.06	0.06	0.06
40	0.05	0.06	0.06	0.05
41	0.06	0.06	0.06	0.06
42	0.07	0.06	0.06	0.06
130	0.22	0.21	0.21	0.21
131	0.19	0.21	0.23	0.19
137	0.12	0.13	0.13	0.12
138	0.1	0.11	0.11	0.1
139	0.12	0.13	0.13	0.12
145	0.11	0.11	0.12	0.11
146	0.11	0.11	0.11	0.11
154	0.07	0.07	0.08	0.07
155	0.06	0.06	0.07	0.06
156	0.06	0.06	0.06	0.06
157	0.05	0.06	0.06	0.05
158	0.07	0.07	0.07	0.07
167	0.07	0.07	0.08	0.07
168	0.06	0.06	0.06	0.06
169	0.07	0.06	0.06	0.06
170	0.06	0.07	0.07	0.06



c) Scaling factor for front module n261

Beam ID	S_LB	S_MB	S_HB	SF
4	0.37	0.3	0.24	0.24
5	0.42	0.3	0.25	0.25
12	0.17	0.14	0.12	0.12
13	0.16	0.16	0.14	0.14
14	0.17	0.18	0.17	0.17
19	0.16	0.16	0.14	0.14
20	0.16	0.17	0.16	0.16
31	0.12	0.1	0.08	0.08
32	0.12	0.1	0.09	0.09
33	0.12	0.14	0.13	0.12
34	0.14	0.11	0.09	0.09
43	0.12	0.1	0.08	0.08
44	0.13	0.14	0.1	0.1
45	0.12	0.13	0.11	0.11
132	0.31	0.25	0.26	0.25
133	0.43	0.37	0.32	0.32
140	0.2	0.15	0.13	0.13
141	0.16	0.13	0.13	0.13
142	0.21	0.18	0.16	0.16
147	0.17	0.13	0.13	0.13
148	0.16	0.13	0.14	0.13
159	0.11	0.1	0.09	0.09
160	0.12	0.09	0.08	0.08
161	0.11	0.09	0.08	0.08
162	0.13	0.12	0.11	0.11
171	0.11	0.09	0.09	0.09
172	0.1	0.08	0.08	0.08
173	0.12	0.1	0.1	0.1
172	0.13	0.18	0.18	0.13
173	0.14	0.13	0.14	0.13
174	0.13	0.13	0.13	0.13
175	0.14	0.13	0.13	0.13



d) Scaling factor for top module n260

Beam ID	S_LB	S_MB	S_HB	SF
0	0.34	0.41	0.43	0.34
1	0.4	0.51	0.61	0.4
6	0.19	0.2	0.23	0.19
7	0.18	0.18	0.21	0.18
8	0.21	0.21	0.31	0.21
15	0.19	0.2	0.24	0.19
16	0.18	0.17	0.19	0.17
21	0.09	0.1	0.12	0.09
22	0.11	0.11	0.17	0.11
23	0.15	0.18	0.18	0.15
24	0.15	0.11	0.17	0.11
25	0.11	0.1	0.12	0.1
36	0.09	0.11	0.16	0.09
37	0.15	0.15	0.18	0.15
38	0.17	0.15	0.19	0.15
39	0.15	0.09	0.15	0.09
128	0.28	0.36	0.54	0.28
129	0.3	0.33	0.55	0.3
134	0.16	0.22	0.3	0.16
135	0.16	0.19	0.27	0.16
136	0.14	0.15	0.21	0.14
143	0.17	0.2	0.29	0.17
144	0.16	0.18	0.25	0.16
149	0.08	0.11	0.16	0.08
150	0.08	0.12	0.21	0.08
151	0.08	0.11	0.14	0.08
152	0.09	0.1	0.15	0.09
153	0.09	0.11	0.16	0.09
164	0.08	0.15	0.19	0.08
165	0.08	0.13	0.17	0.08
166	0.08	0.1	0.14	0.08
167	0.09	0.1	0.15	0.09



e) *Scaling factor for bottom module n260*

Beam ID	S_LB	S_MB	S_HB	SF
2	0.35	0.32	0.35	0.32
3	0.4	0.51	0.61	0.4
9	0.19	0.2	0.21	0.19
10	0.18	0.18	0.21	0.18
11	0.2	0.21	0.3	0.2
17	0.19	0.21	0.24	0.19
18	0.17	0.17	0.19	0.17
26	0.09	0.1	0.12	0.09
27	0.11	0.11	0.17	0.11
28	0.14	0.16	0.17	0.14
29	0.15	0.12	0.18	0.12
30	0.12	0.1	0.13	0.1
40	0.09	0.1	0.12	0.09
41	0.12	0.11	0.17	0.11
42	0.16	0.14	0.18	0.14
43	0.17	0.11	0.16	0.11
130	0.33	0.38	0.48	0.33
131	0.3	0.33	0.55	0.3
137	0.16	0.2	0.27	0.16
138	0.16	0.19	0.27	0.16
139	0.14	0.15	0.21	0.14
145	0.17	0.2	0.29	0.17
146	0.16	0.18	0.26	0.16
154	0.08	0.13	0.14	0.08
155	0.08	0.12	0.21	0.08
156	0.08	0.11	0.13	0.08
157	0.09	0.11	0.14	0.09
158	0.09	0.11	0.16	0.09
168	0.08	0.13	0.24	0.08
169	0.08	0.11	0.15	0.08
170	0.09	0.1	0.14	0.09
171	0.09	0.11	0.16	0.09



f) Scaling factor for front module n260

Beam ID	S_LB	S_MB	S_HB	SF
4	0.37	0.44	0.41	0.37
5	0.59	0.52	0.47	0.47
12	0.22	0.25	0.27	0.22
13	0.21	0.3	0.21	0.21
14	0.22	0.21	0.22	0.21
19	0.19	0.29	0.2	0.19
20	0.25	0.26	0.28	0.25
31	0.12	0.14	0.15	0.12
32	0.12	0.15	0.14	0.12
33	0.12	0.15	0.11	0.11
34	0.16	0.17	0.16	0.16
35	0.15	0.15	0.16	0.15
44	0.12	0.15	0.16	0.12
45	0.12	0.14	0.14	0.12
46	0.13	0.18	0.12	0.12
47	0.15	0.16	0.16	0.15
132	0.42	0.5	0.48	0.42
133	0.35	0.51	0.57	0.35
140	0.25	0.26	0.25	0.25
141	0.28	0.29	0.28	0.28
142	0.21	0.26	0.22	0.21
147	0.28	0.31	0.32	0.28
148	0.23	0.27	0.23	0.23
159	0.14	0.2	0.21	0.14
160	0.15	0.15	0.16	0.15
161	0.13	0.13	0.14	0.13
162	0.13	0.13	0.13	0.13
163	0.16	0.21	0.14	0.14
172	0.13	0.18	0.18	0.13
173	0.14	0.13	0.14	0.13
174	0.13	0.13	0.13	0.13
175	0.14	0.13	0.13	0.13



Data for Paired Beams:

a) Scaling factor for top module n261

BeamID1	BeamID2	S_LB	S_MB	S_HB	SF
0	128	0.1	0.11	0.11	0.1
1	129	0.1	0.1	0.1	0.1
6	134	0.05	0.05	0.06	0.05
7	135	0.05	0.05	0.05	0.05
8	136	0.05	0.06	0.06	0.05
15	143	0.04	0.05	0.05	0.04
16	144	0.06	0.06	0.06	0.06
21	149	0.04	0.03	0.03	0.03
22	150	0.03	0.03	0.03	0.03
23	151	0.03	0.03	0.03	0.03
24	152	0.03	0.03	0.03	0.03
25	153	0.03	0.04	0.04	0.03
35	163	0.03	0.03	0.03	0.03
36	164	0.02	0.03	0.03	0.02
37	165	0.03	0.03	0.03	0.03
38	166	0.03	0.03	0.03	0.03

b) Scaling factor for bottom module n261

BeamID1	BeamID2	S_LB	S_MB	S_HB	SF
2	130	0.09	0.1	0.1	0.09
3	131	0.1	0.1	0.1	0.1
9	137	0.05	0.05	0.06	0.05
10	138	0.04	0.05	0.05	0.04
11	139	0.06	0.06	0.06	0.06
17	145	0.04	0.05	0.05	0.04
18	146	0.05	0.05	0.05	0.05
26	154	0.03	0.03	0.03	0.03
27	155	0.03	0.03	0.03	0.03
28	156	0.03	0.03	0.03	0.03
29	157	0.03	0.03	0.03	0.03
30	158	0.03	0.04	0.04	0.03
39	167	0.03	0.03	0.03	0.03
40	168	0.03	0.03	0.03	0.03
41	169	0.03	0.03	0.03	0.03
42	170	0.03	0.03	0.03	0.03



c) Scaling factor for front module n261

BeamID1	BeamID2	S_LB	S_MB	S_HB	SF
4	132	0.13	0.12	0.11	0.11
5	133	0.18	0.14	0.12	0.12
12	140	0.08	0.07	0.06	0.06
13	141	0.08	0.07	0.06	0.06
14	142	0.13	0.11	0.11	0.11
19	147	0.08	0.07	0.06	0.06
20	148	0.07	0.08	0.07	0.07
31	159	0.06	0.04	0.04	0.04
32	160	0.06	0.04	0.04	0.04
33	161	0.05	0.05	0.04	0.04
34	162	0.05	0.05	0.05	0.05
43	171	0.06	0.04	0.03	0.03
44	172	0.05	0.04	0.04	0.04
45	173	0.05	0.05	0.05	0.05
46	174	0.05	0.07	0.05	0.05
47	175	0.05	0.06	0.06	0.05

d) Scaling factor for top module n260

BeamID1	BeamID2	S_LB	S_MB	S_HB	SF
0	128	0.14	0.17	0.22	0.14
1	129	0.15	0.16	0.28	0.15
6	134	0.08	0.09	0.11	0.08
7	135	0.08	0.09	0.11	0.08
8	136	0.08	0.08	0.11	0.08
15	143	0.08	0.09	0.11	0.08
16	144	0.07	0.08	0.1	0.07
21	149	0.04	0.05	0.06	0.04
22	150	0.04	0.05	0.08	0.04
23	151	0.05	0.06	0.07	0.05
24	152	0.05	0.05	0.07	0.05
25	153	0.05	0.05	0.06	0.05
36	164	0.04	0.05	0.06	0.04
37	165	0.05	0.06	0.08	0.05
38	166	0.06	0.06	0.07	0.06
39	167	0.05	0.05	0.07	0.05



e) Scaling factor for bottom module n260

BeamID1	BeamID2	S_LB	S_MB	S_HB	SF
2	130	0.15	0.16	0.19	0.15
3	131	0.15	0.16	0.28	0.15
9	137	0.11	0.13	0.12	0.11
10	138	0.08	0.09	0.12	0.08
11	139	0.08	0.08	0.11	0.08
17	145	0.08	0.09	0.11	0.08
18	146	0.07	0.08	0.1	0.07
26	154	0.04	0.04	0.06	0.04
27	155	0.04	0.05	0.08	0.04
28	156	0.04	0.06	0.07	0.04
29	157	0.06	0.05	0.07	0.05
30	158	0.05	0.05	0.06	0.05
40	168	0.04	0.05	0.06	0.04
41	169	0.04	0.05	0.07	0.04
42	170	0.05	0.06	0.07	0.05
43	171	0.05	0.05	0.07	0.05

f) Scaling factor for front module n260

BeamID1	BeamID2	S_LB	S_MB	S_HB	SF
4	132	0.16	0.2	0.16	0.16
5	133	0.18	0.22	0.21	0.18
12	140	0.1	0.13	0.13	0.1
13	141	0.11	0.13	0.11	0.11
14	142	0.1	0.11	0.1	0.1
19	147	0.1	0.12	0.11	0.1
20	148	0.1	0.11	0.11	0.1
31	159	0.05	0.07	0.08	0.05
32	160	0.05	0.06	0.07	0.05
33	161	0.05	0.06	0.05	0.05
34	162	0.05	0.06	0.05	0.05
35	163	0.06	0.06	0.07	0.06
44	172	0.05	0.07	0.08	0.05
45	173	0.05	0.06	0.05	0.05
46	174	0.05	0.07	0.05	0.05
47	175	0.05	0.06	0.06	0.05



Appendix C: Simulated PD Distribution Plots

The evaluation planes are illustrated in the figure, below.

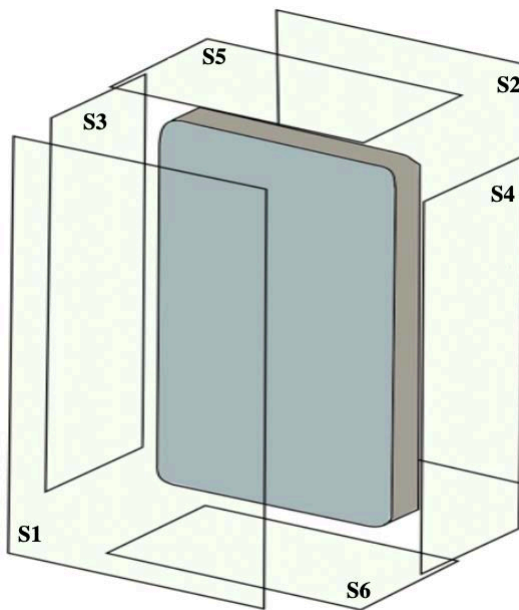

Table C1. PD Evaluation planes (any distance less than 1 cm is reported as 0 cm).

	Front (S1)	Rear (S2)	Left from Front View (S3)	Right from Front View (S4)	Top (S5)	Bottom (S6)
Top Module	Yes (0 cm)	Yes (0 cm)	Yes (0 cm)	No (14 cm)	Yes (0 cm)	No (24 cm)
Bottom Module	Yes (0 cm)	Yes (0 cm)	No (14 cm)	Yes (0 cm)	No (24 cm)	Yes (0 cm)
Front Module	Yes (0 cm)	Yes (0 cm)	No (17 cm)	Yes (0 cm)	No (7 cm)	No (18 cm)

The power density plots (i.e., power density per grid points without any averaging) for all the Beam IDs across nearby evaluation planes for the top, bottom, and front module arrays are shown, below (unit: [W/m²]). For the front array, plots are not provided for S2 because the iPad body introduces a shielding effect and the leaking field to S2 is very weak (this was reflected in the reported very low value MPE's). Also, please note that each surface plot is normalized to the maximum power density of all evaluated surfaces for that Beam ID.



Module: Top Array, Band:n261, Power Density Plot for Beam ID:0

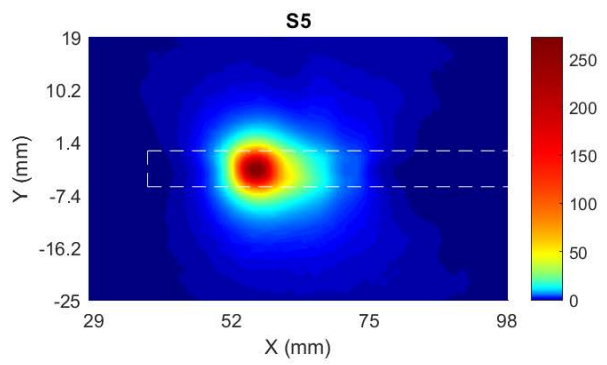
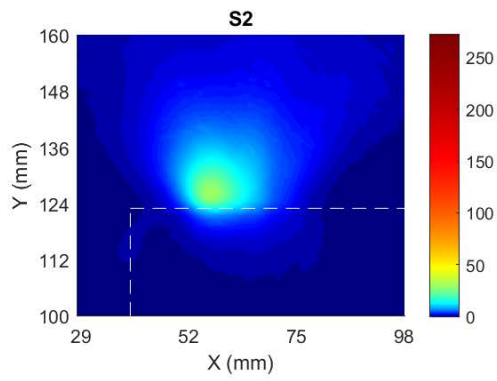
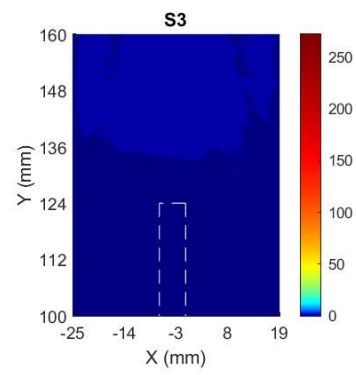
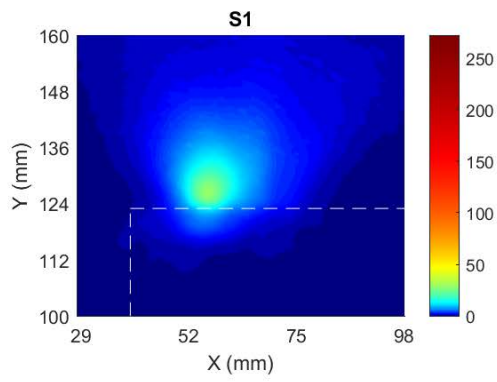



Module: Top Array, Band:n261, Power Density Plot for Beam ID:1

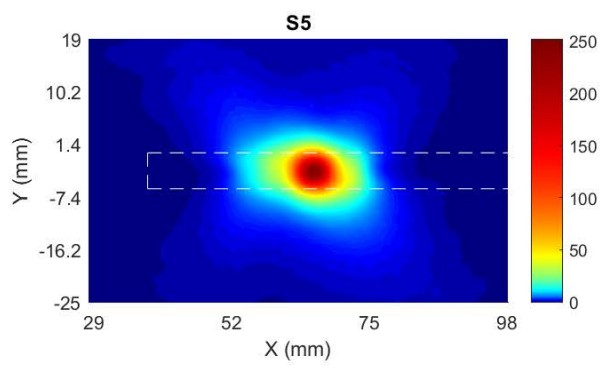
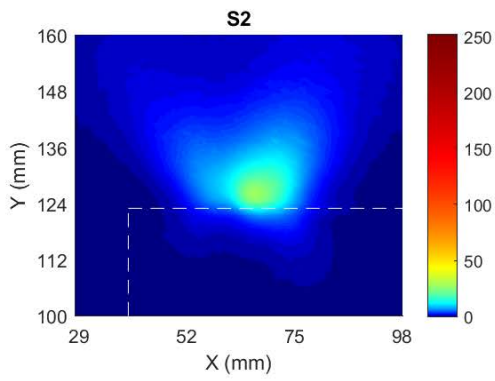
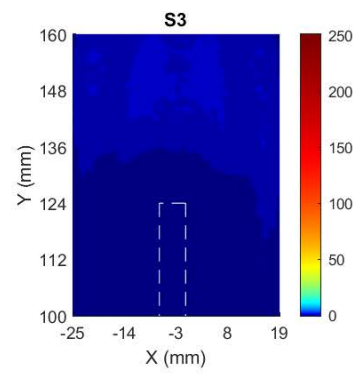
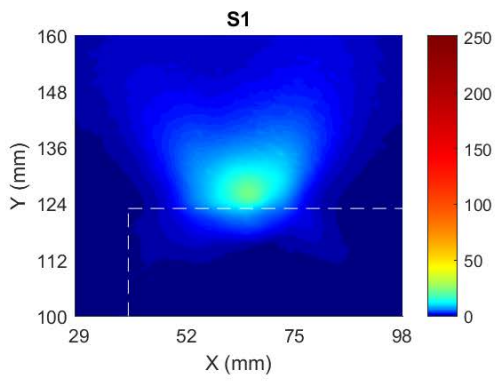



Module: Top Array, Band:n261, Power Density Plot for Beam ID:6

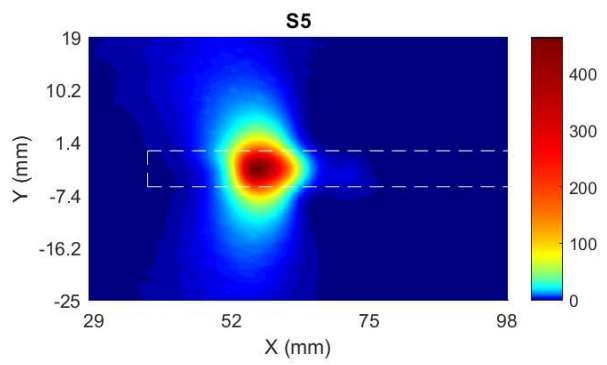
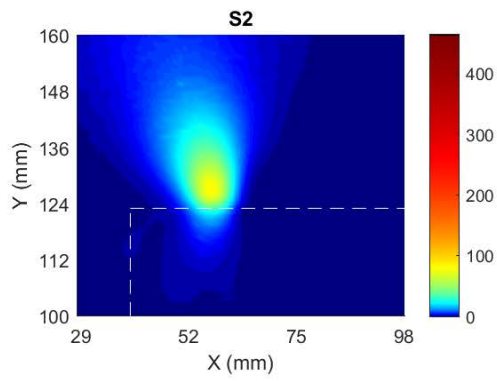
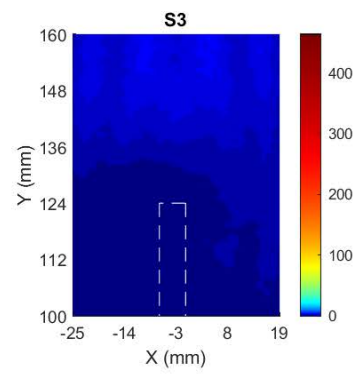
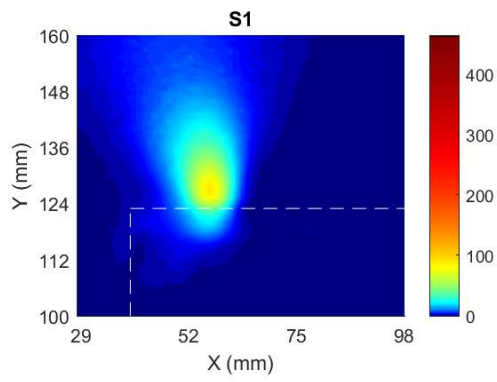



Module: Top Array, Band:n261, Power Density Plot for Beam ID:7

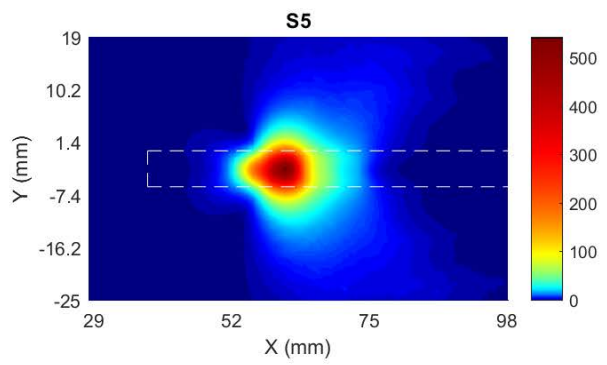
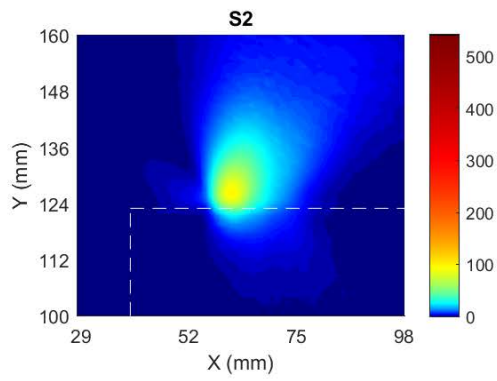
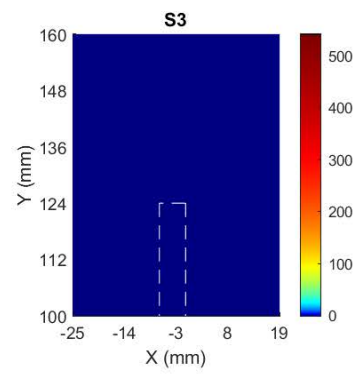
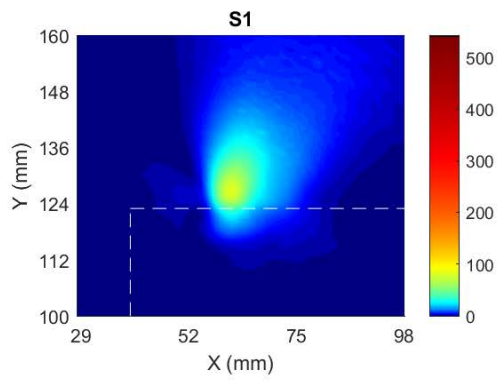



Module: Top Array, Band:n261, Power Density Plot for Beam ID:8

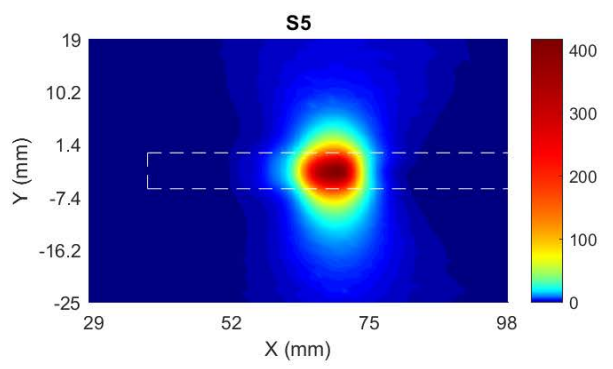
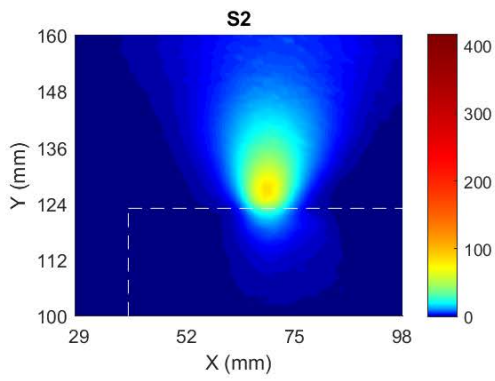
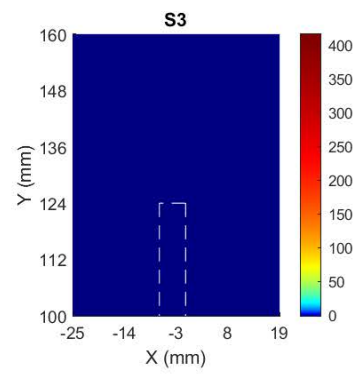
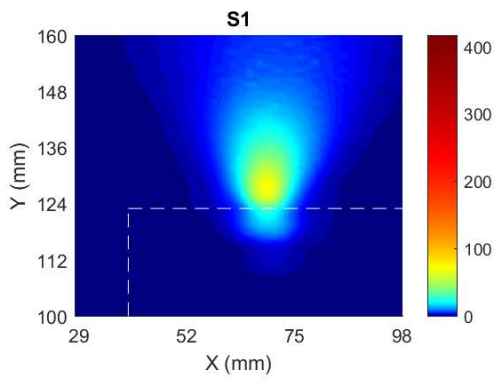



Module: Top Array, Band:n261, Power Density Plot for Beam ID:15

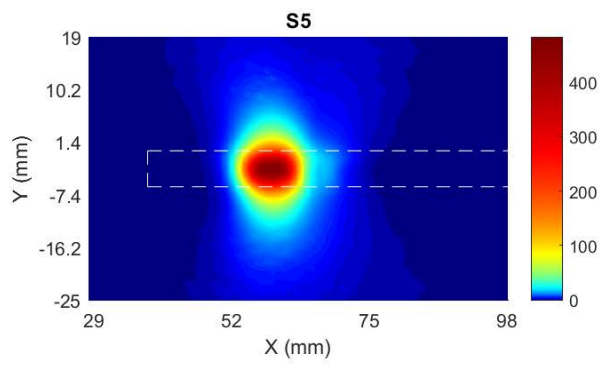
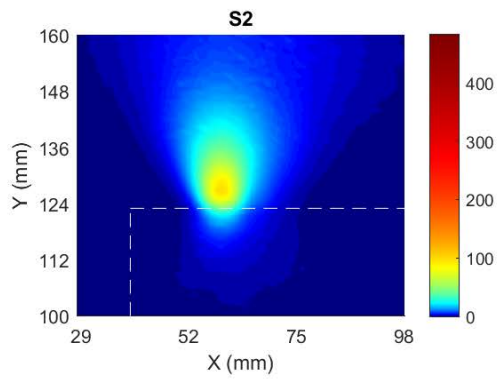
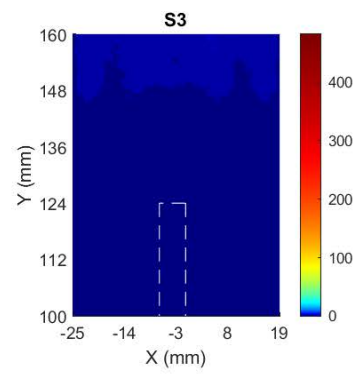
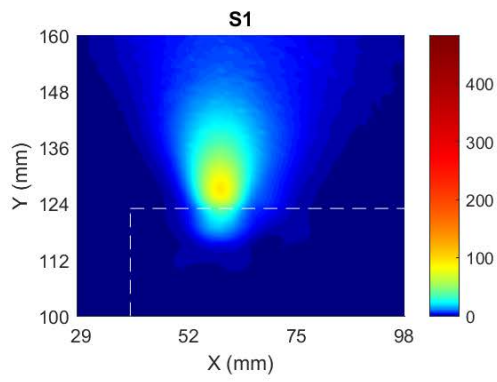



Module: Top Array, Band:n261, Power Density Plot for Beam ID:16

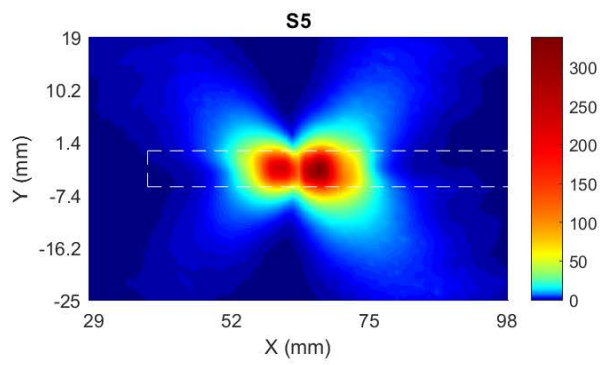
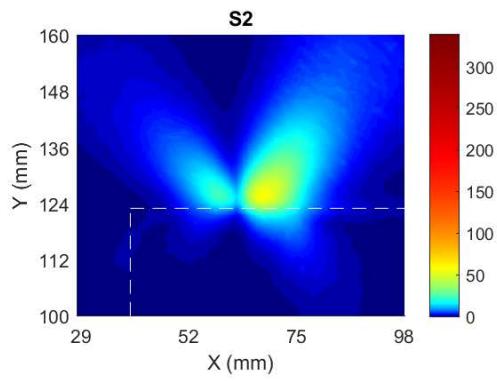
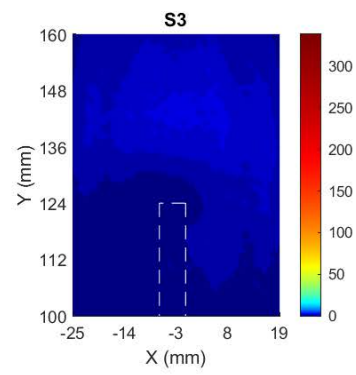
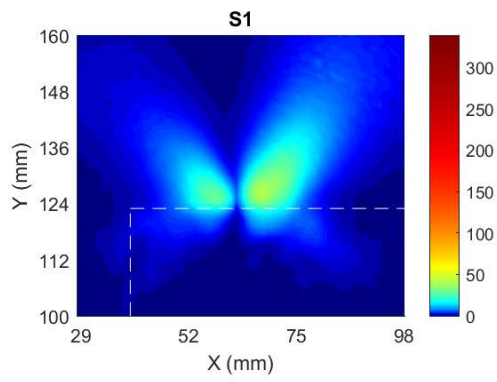



Module: Top Array, Band:n261, Power Density Plot for Beam ID:21

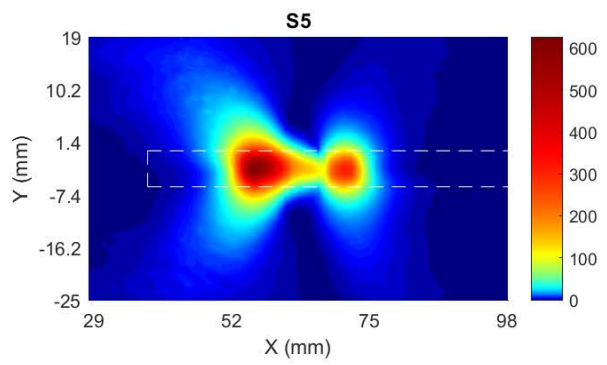
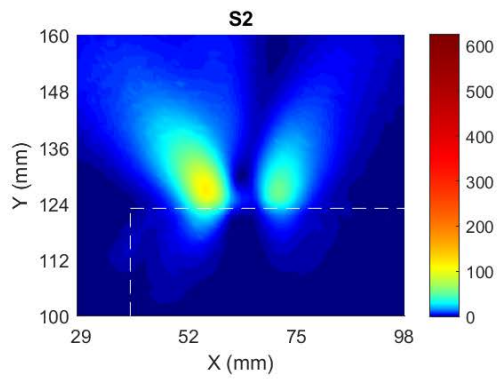
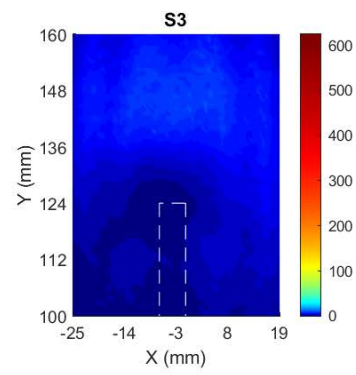
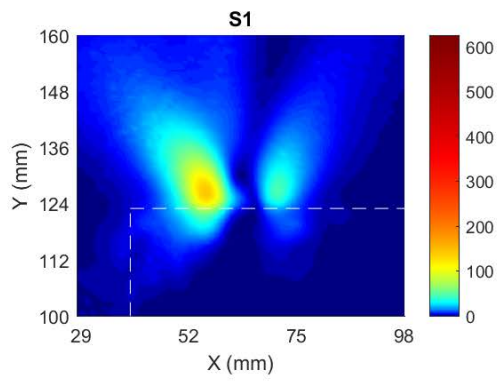



Module: Top Array, Band:n261, Power Density Plot for Beam ID:22

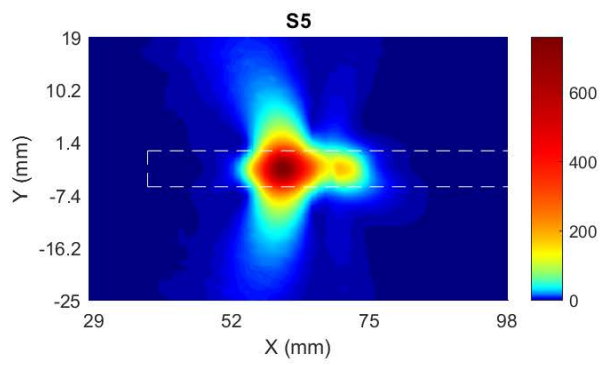
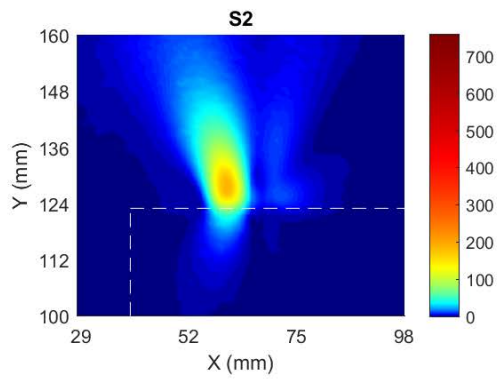
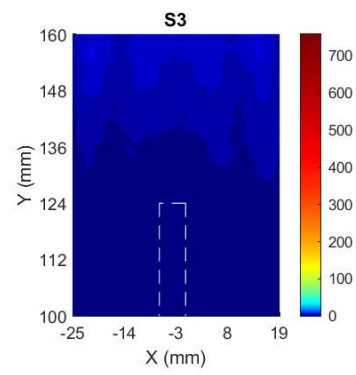
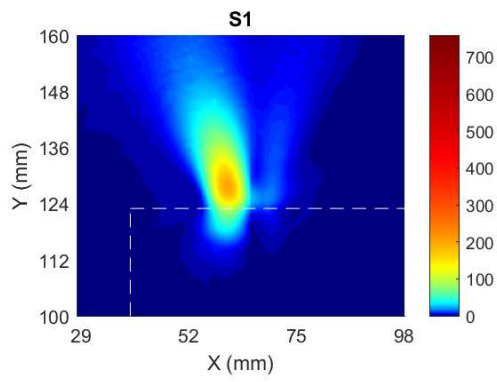



Module: Top Array, Band:n261, Power Density Plot for Beam ID:23

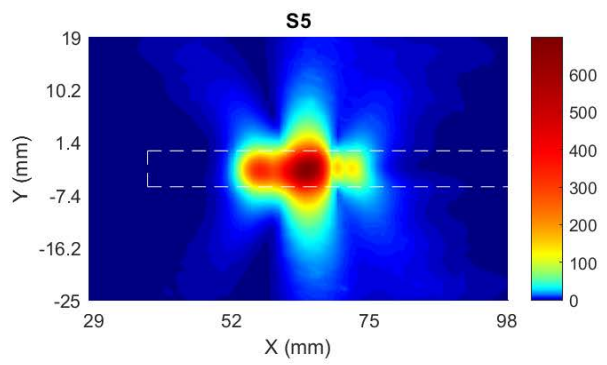
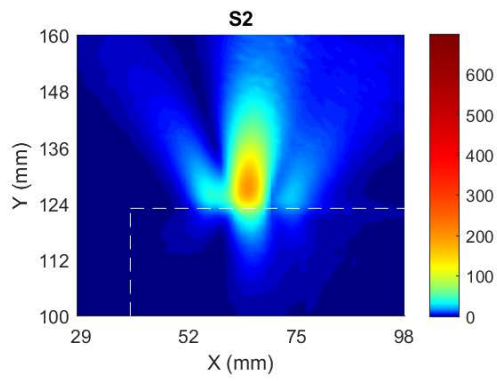
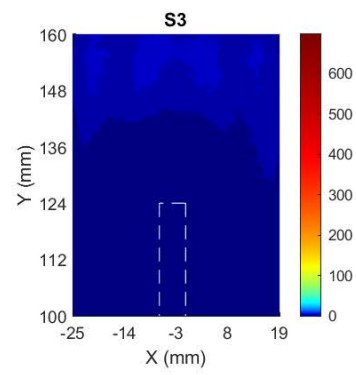
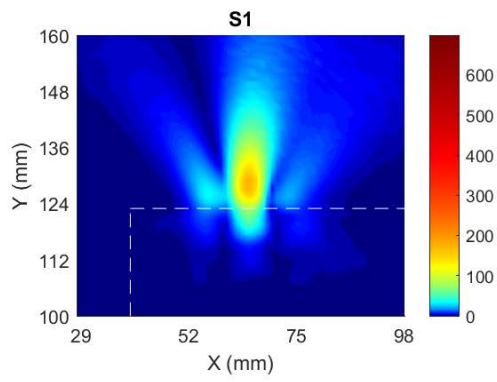



Module: Top Array, Band:n261, Power Density Plot for Beam ID:24

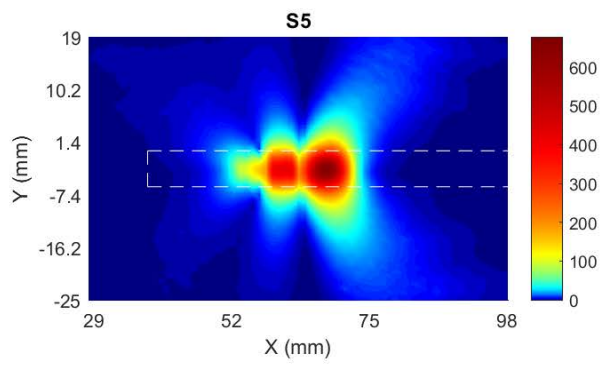
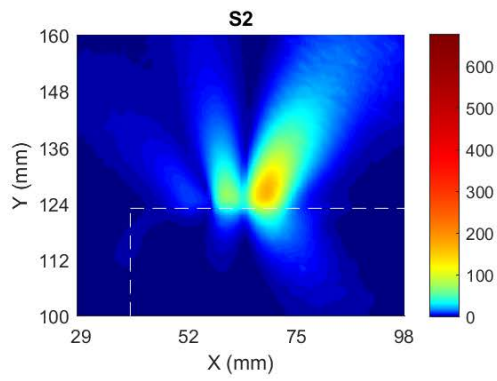
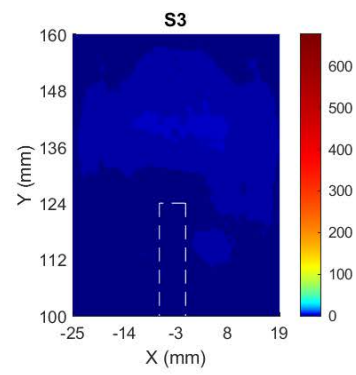
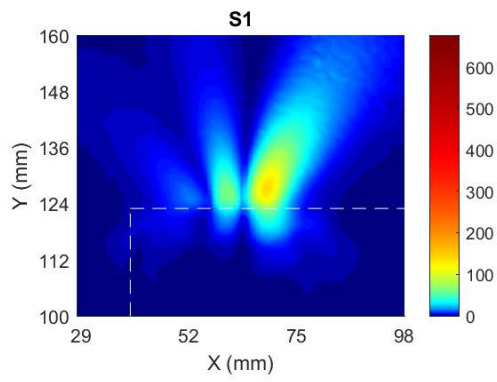



Module: Top Array, Band:n261, Power Density Plot for Beam ID:25

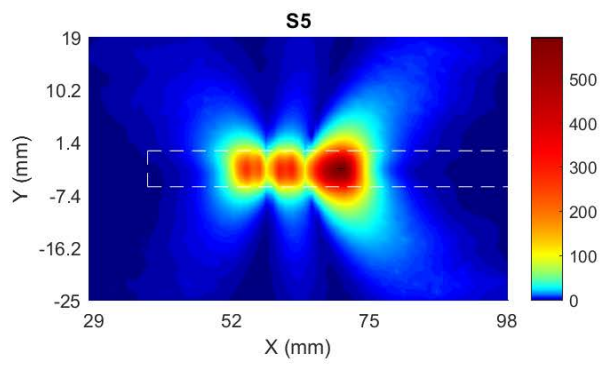
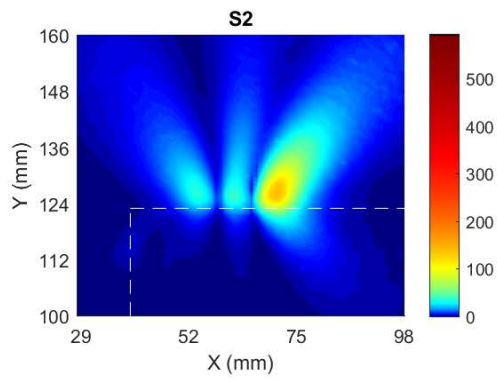
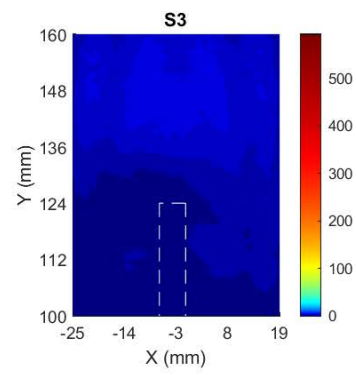
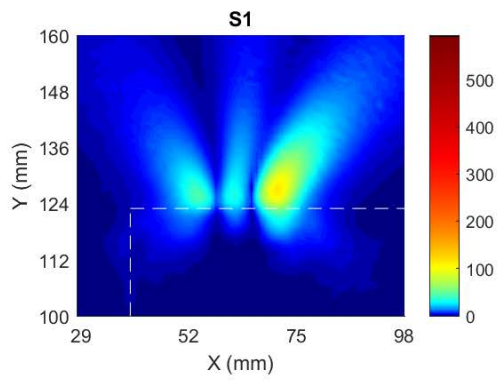



Module: Top Array, Band:n261, Power Density Plot for Beam ID:35

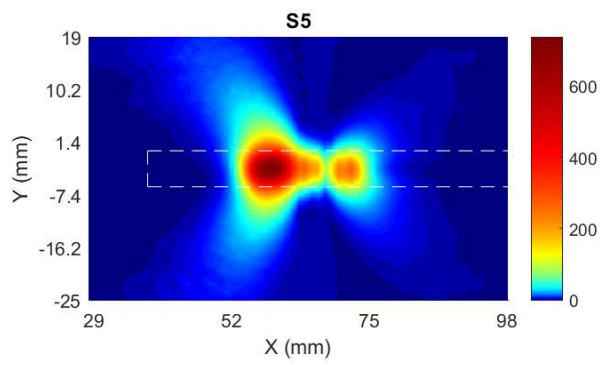
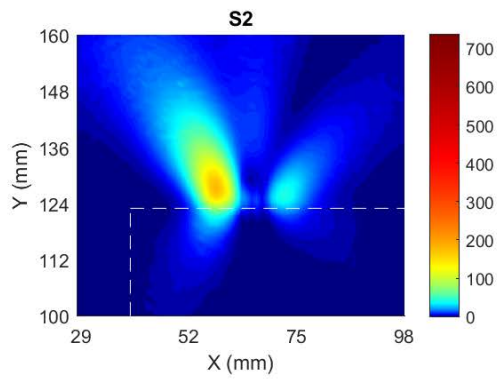
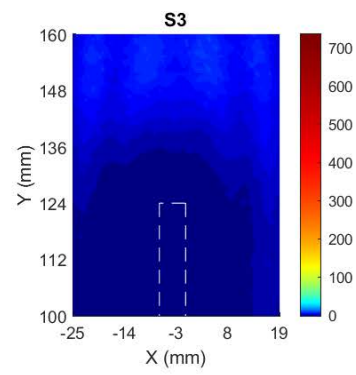
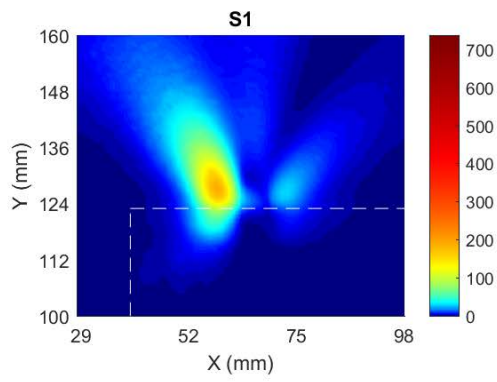



Module: Top Array, Band:n261, Power Density Plot for Beam ID:36

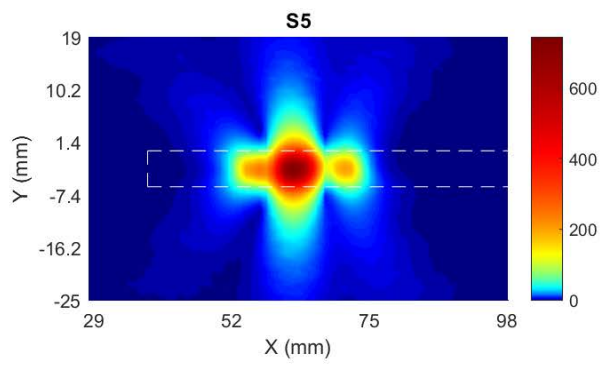
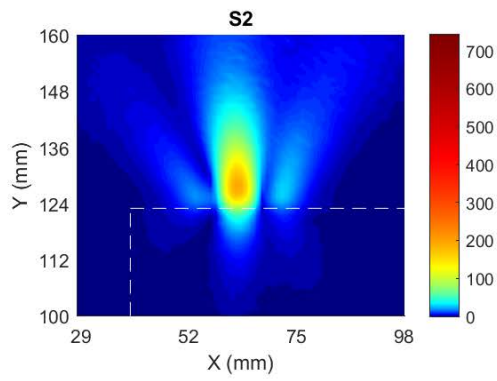
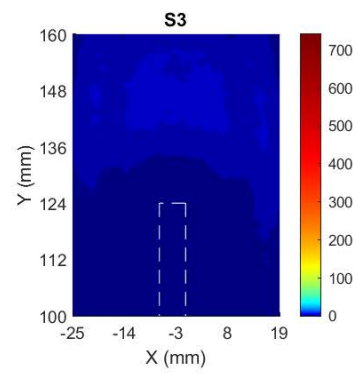
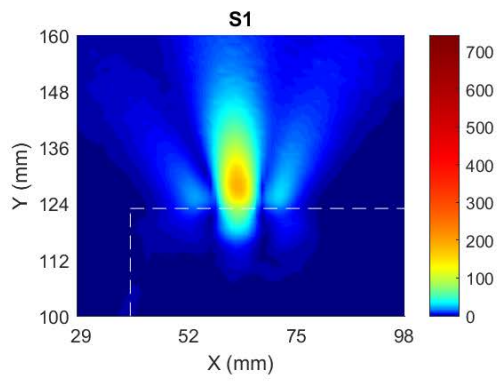



Module: Top Array, Band:n261, Power Density Plot for Beam ID:37

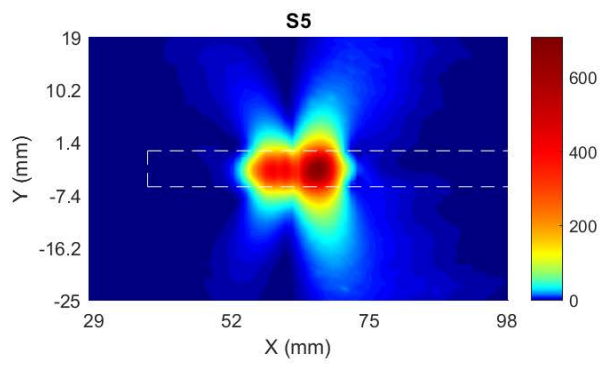
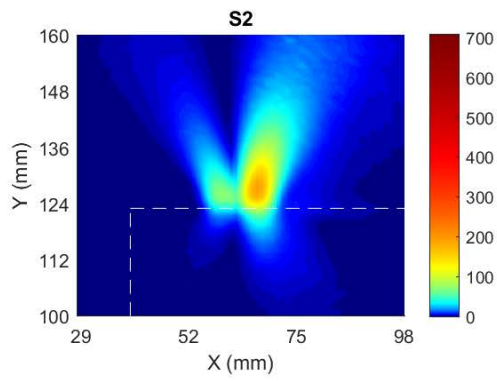
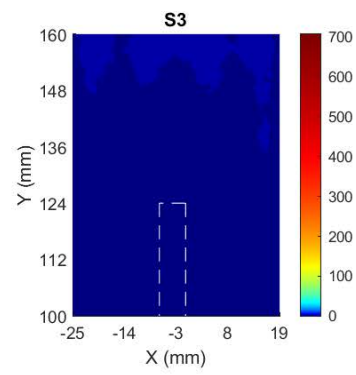
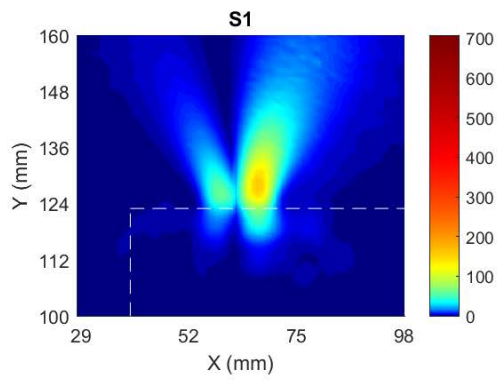



Module: Top Array, Band:n261, Power Density Plot for Beam ID:38

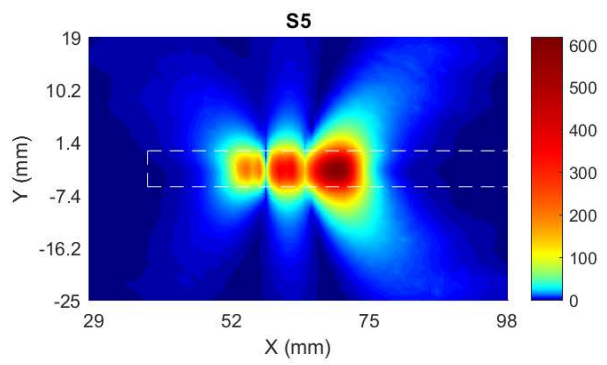
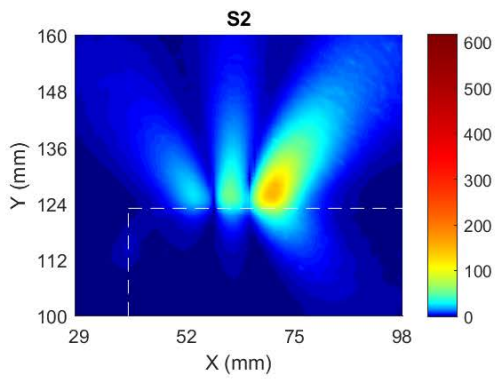
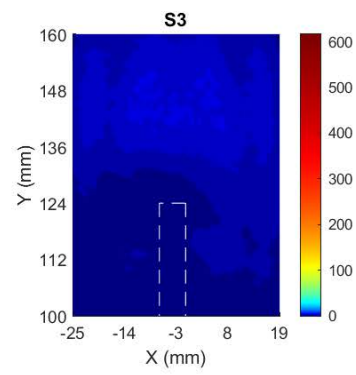
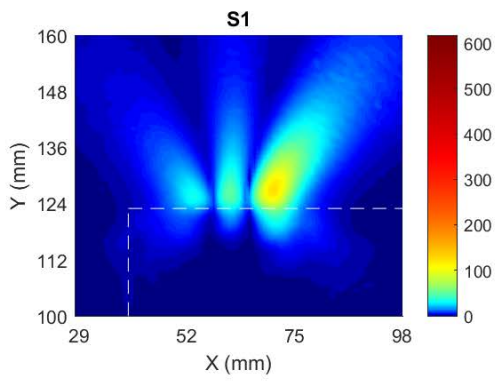



Module: Top Array, Band:n261, Power Density Plot for Beam ID:128

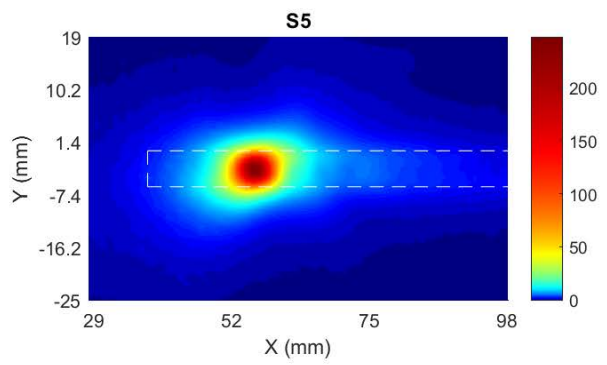
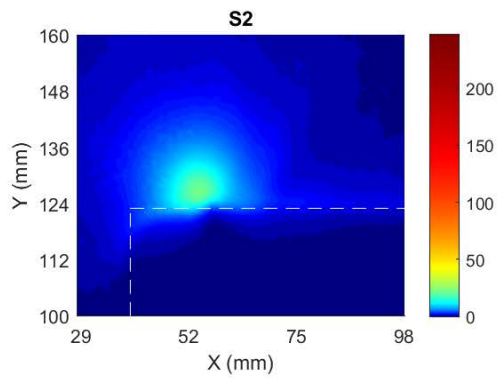
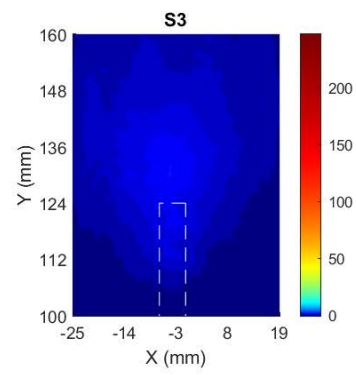
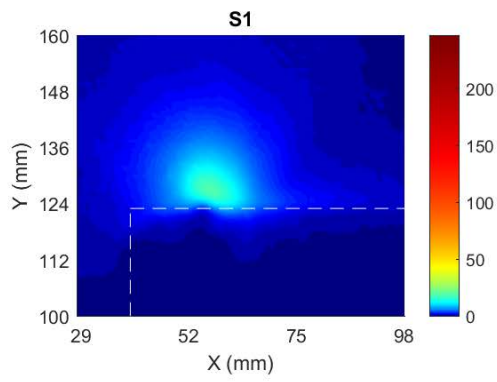



Module: Top Array, Band:n261, Power Density Plot for Beam ID:129

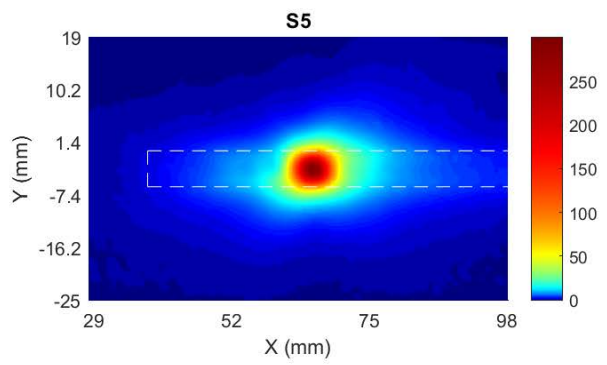
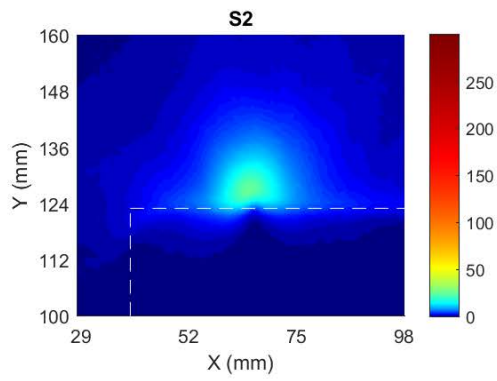
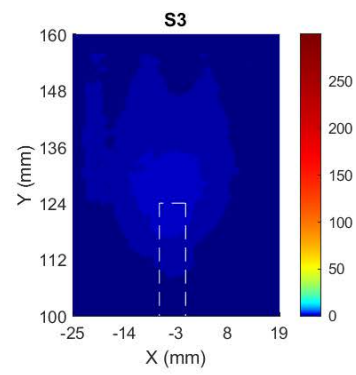
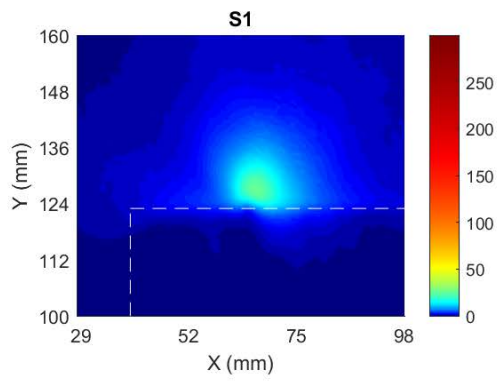



Module: Top Array, Band:n261, Power Density Plot for Beam ID:134

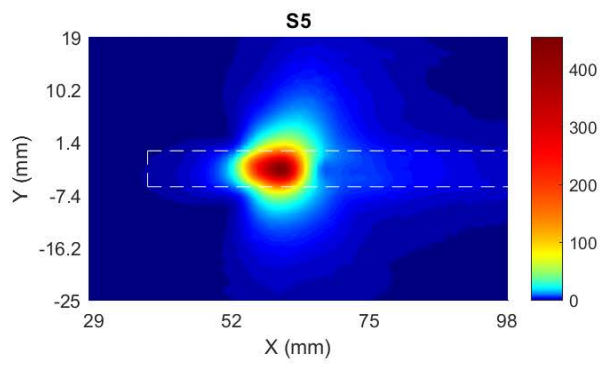
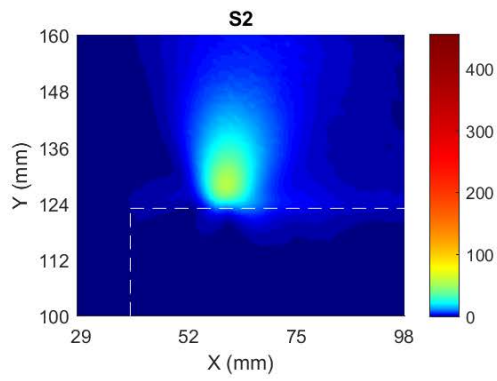
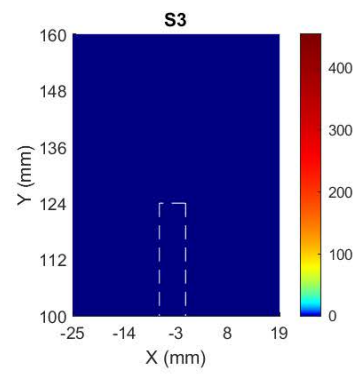
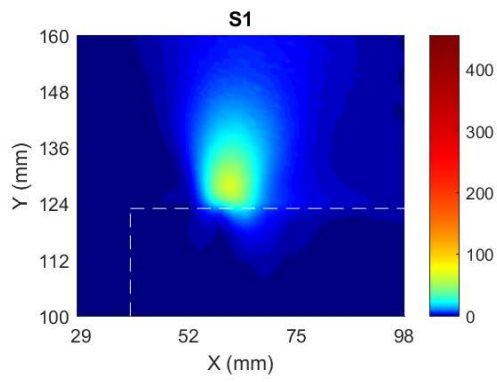



Module: Top Array, Band:n261, Power Density Plot for Beam ID:135

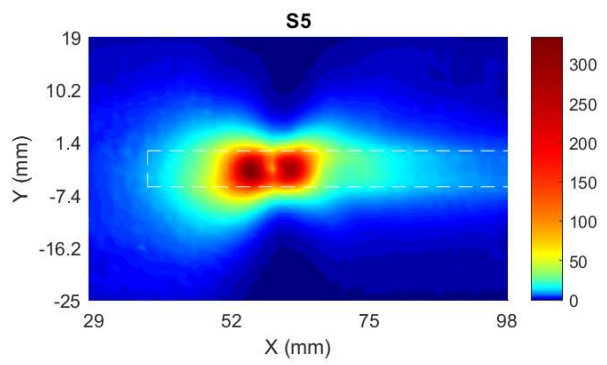
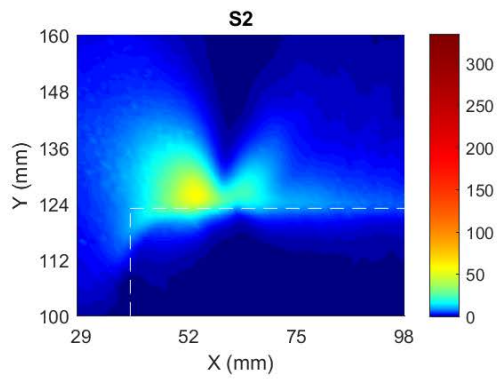
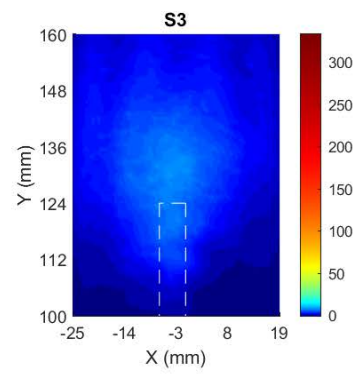
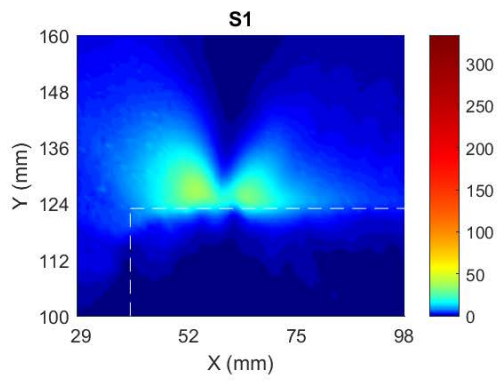



Module: Top Array, Band:n261, Power Density Plot for Beam ID:136

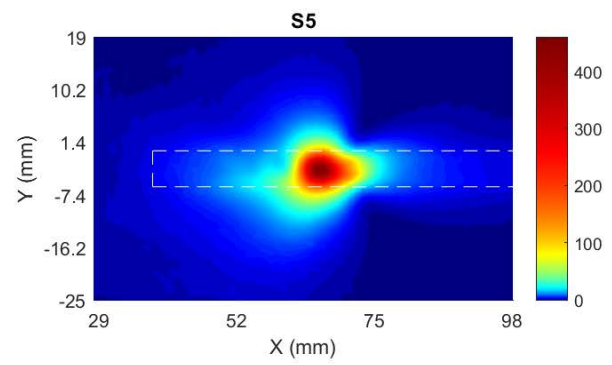
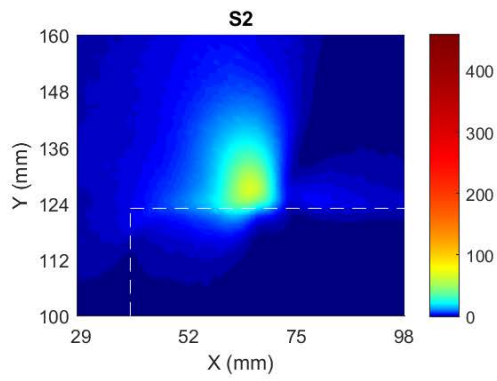
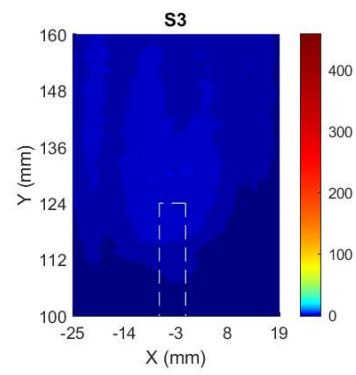
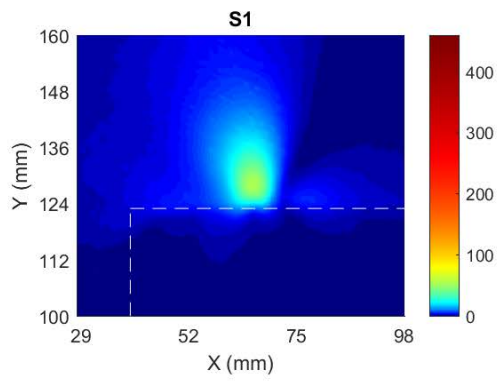



Module: Top Array, Band:n261, Power Density Plot for Beam ID:143

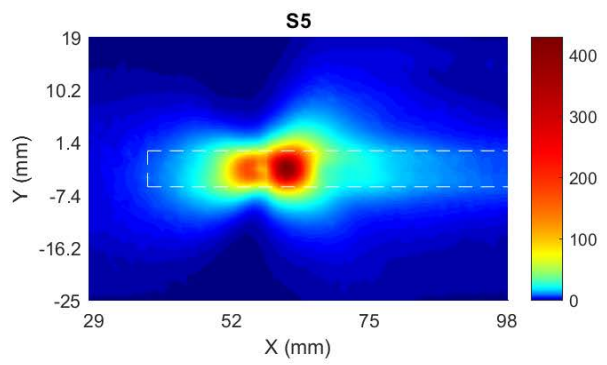
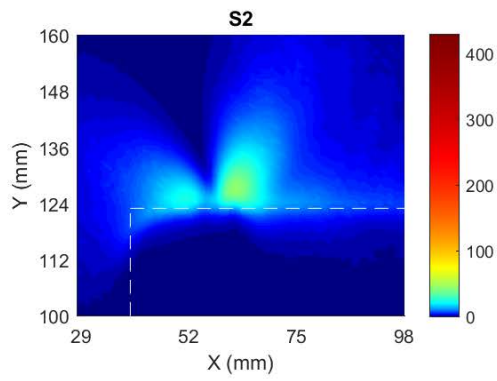
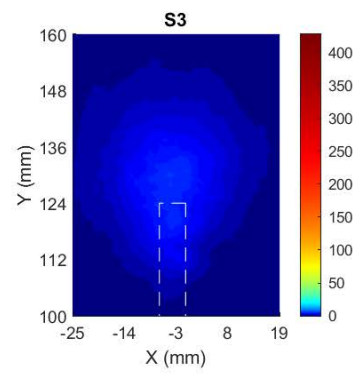
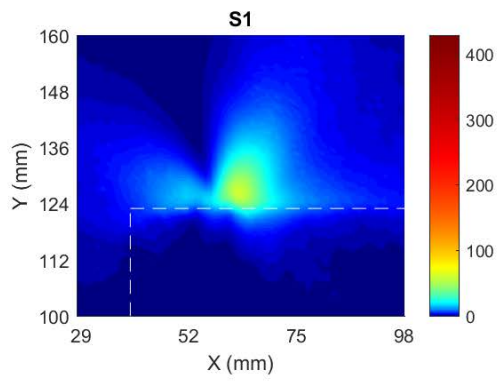



Module: Top Array, Band:n261, Power Density Plot for Beam ID:144

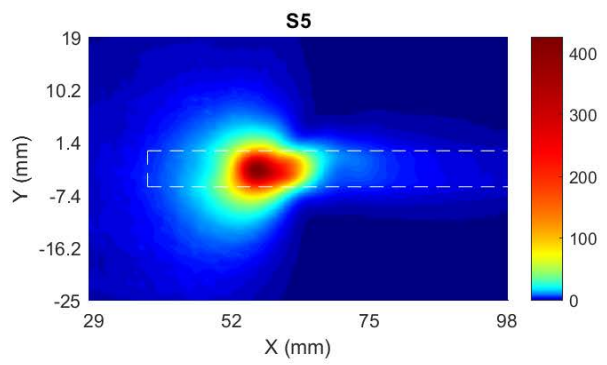
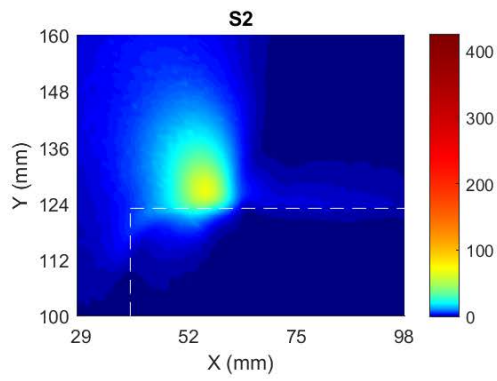
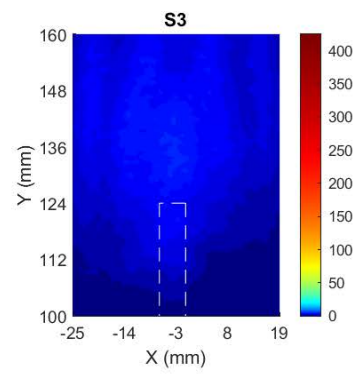
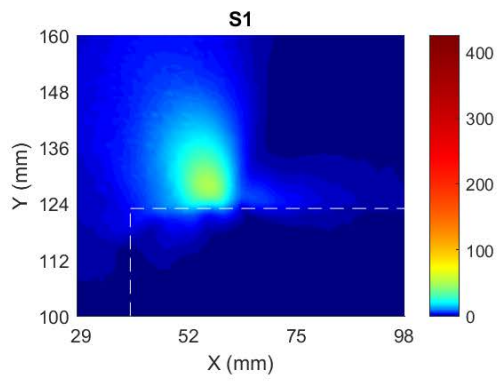



Module: Top Array, Band:n261, Power Density Plot for Beam ID:149

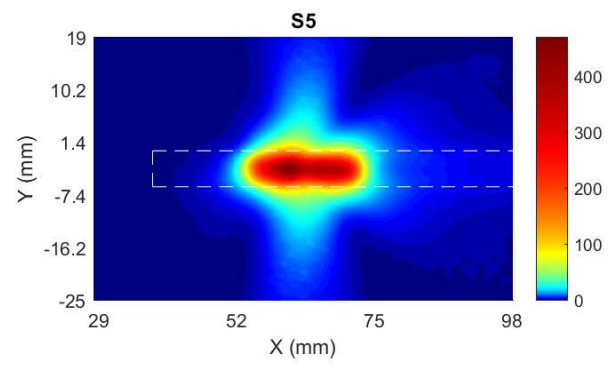
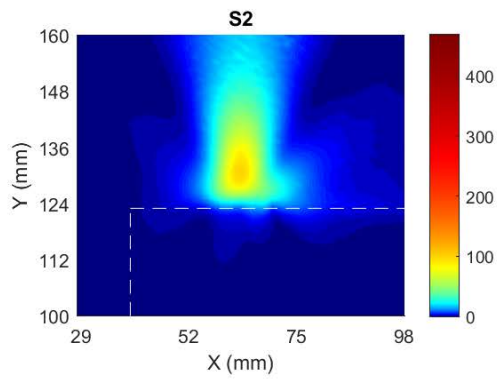
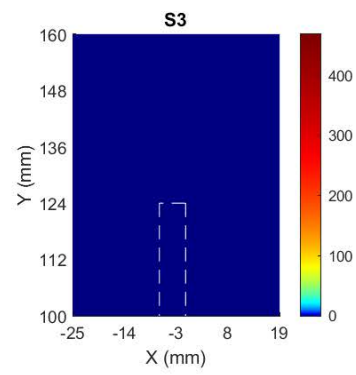
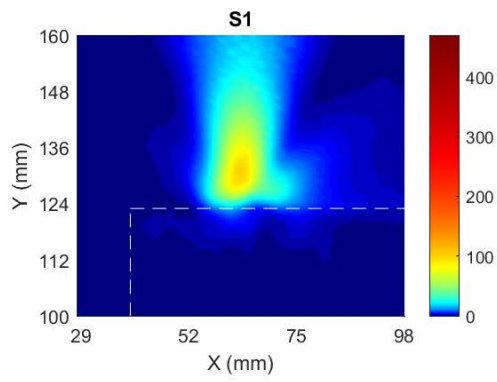



Module: Top Array, Band:n261, Power Density Plot for Beam ID:150

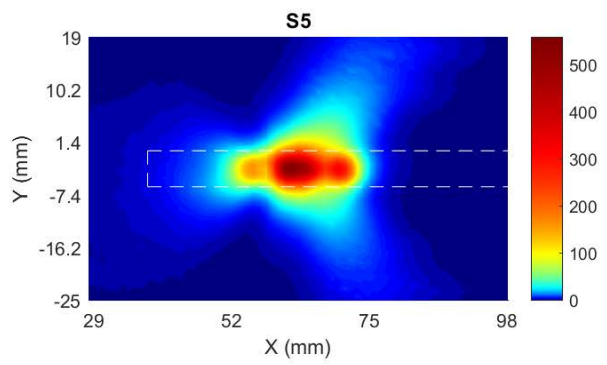
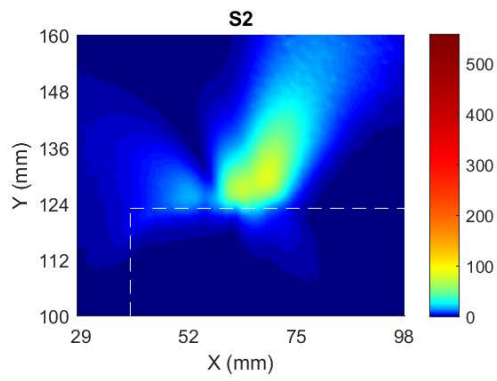
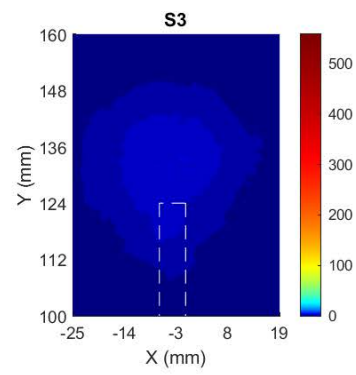
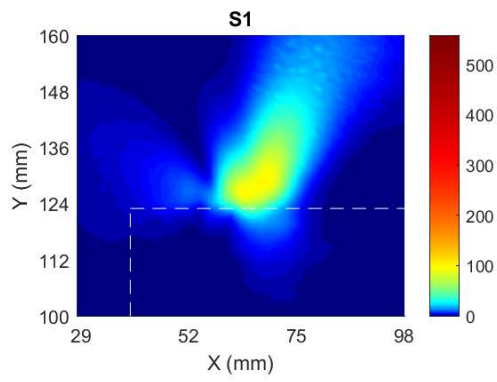



Module: Top Array, Band:n261, Power Density Plot for Beam ID:151

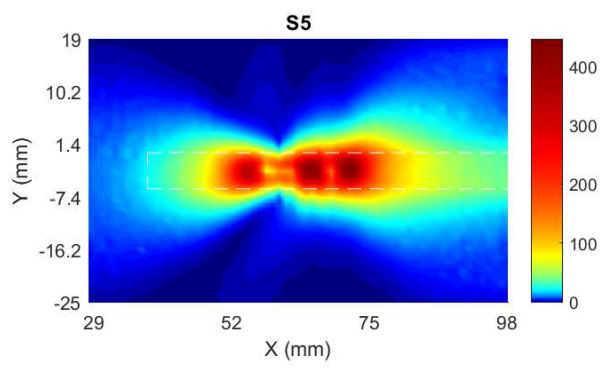
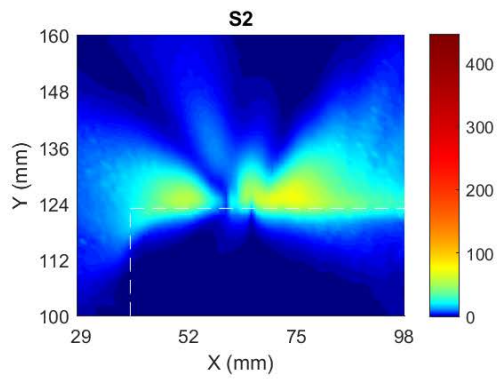
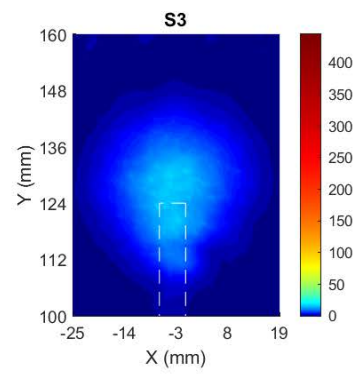
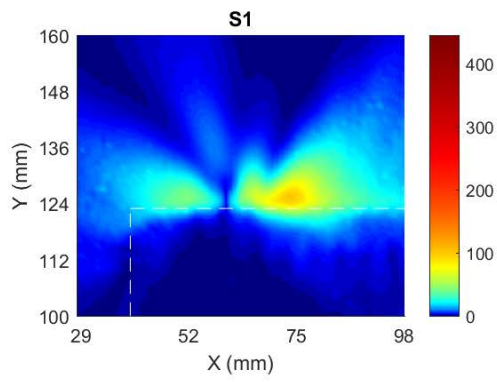



Module: Top Array, Band:n261, Power Density Plot for Beam ID:152

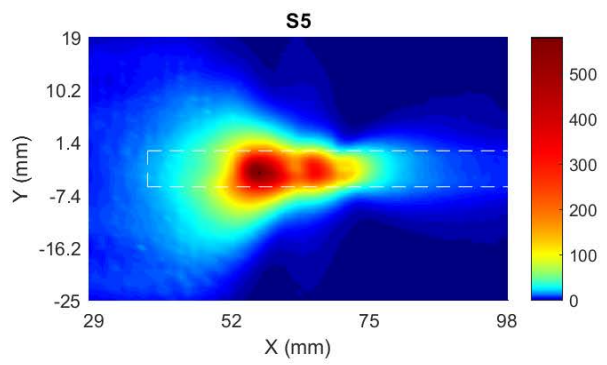
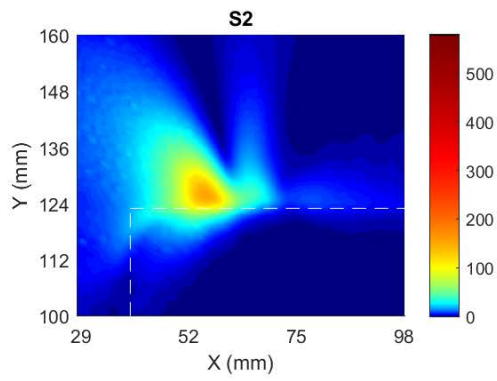
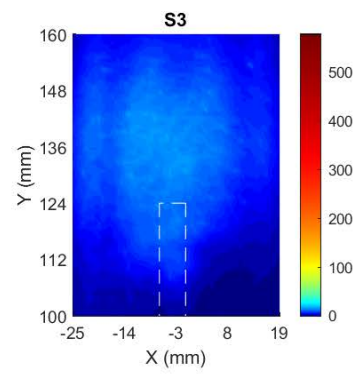
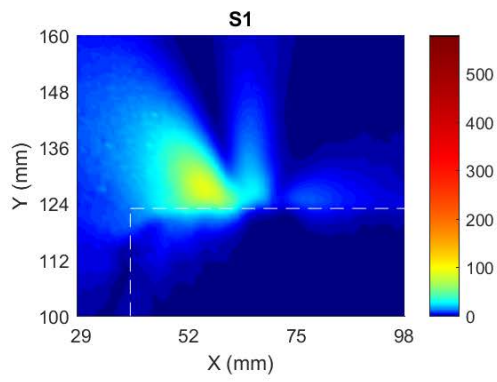



Module: Top Array, Band:n261, Power Density Plot for Beam ID:153

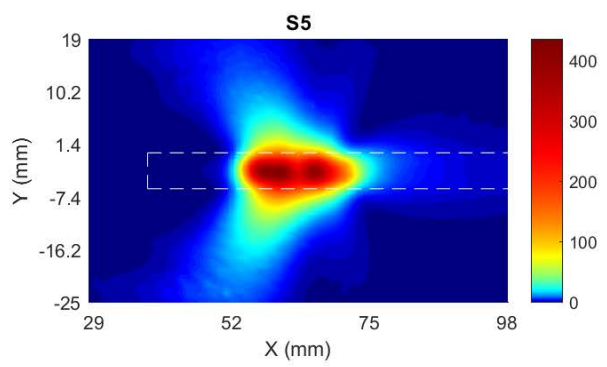
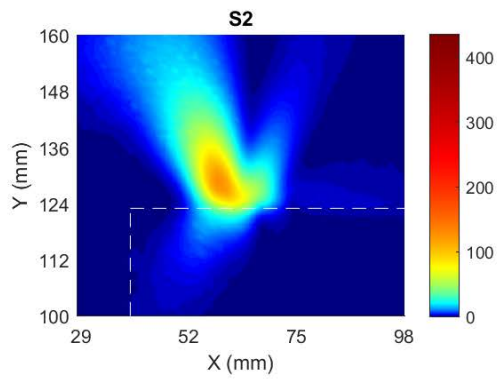
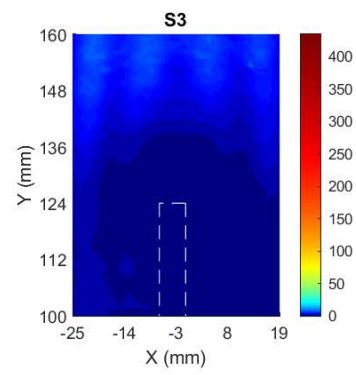
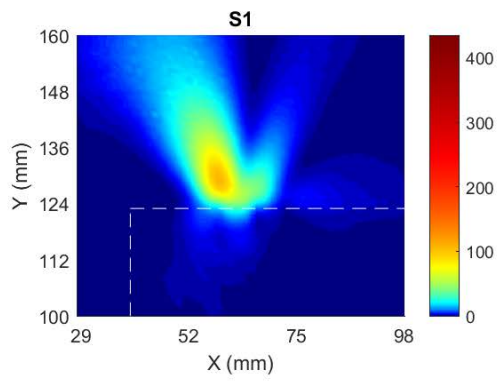



Module: Top Array, Band:n261, Power Density Plot for Beam ID:163

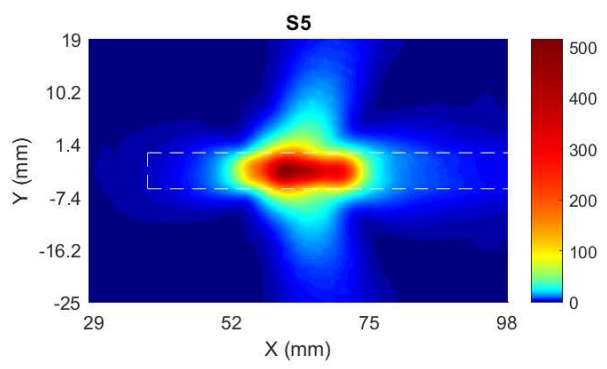
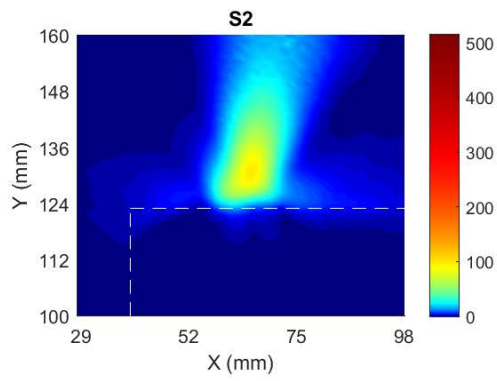
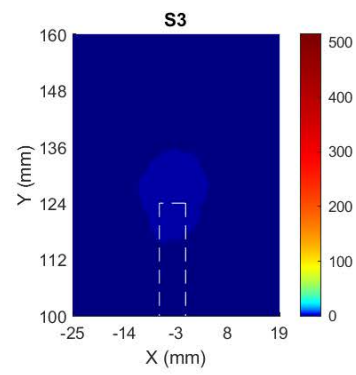
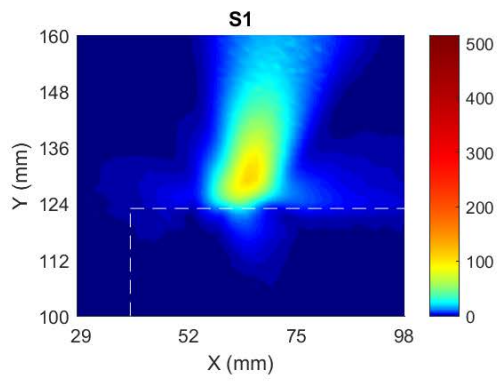



Module: Top Array, Band:n261, Power Density Plot for Beam ID:164

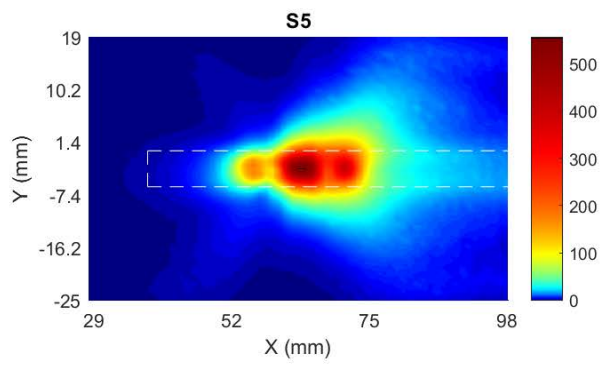
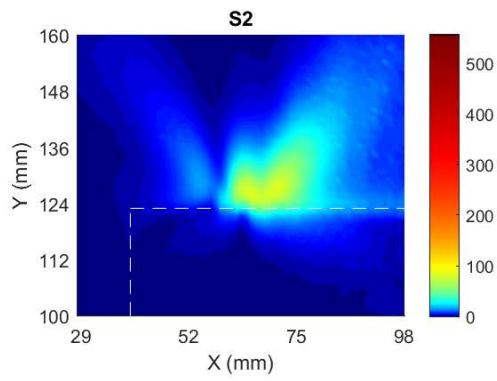
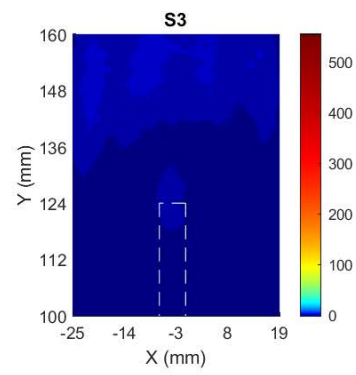
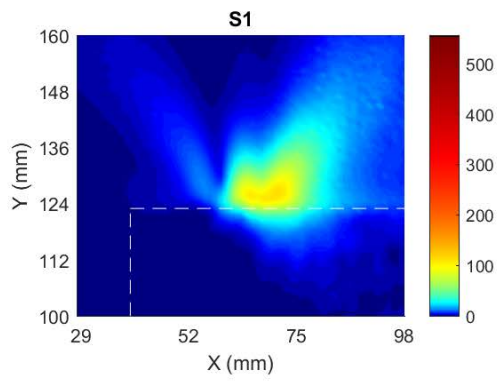



Module: Top Array, Band:n261, Power Density Plot for Beam ID:165

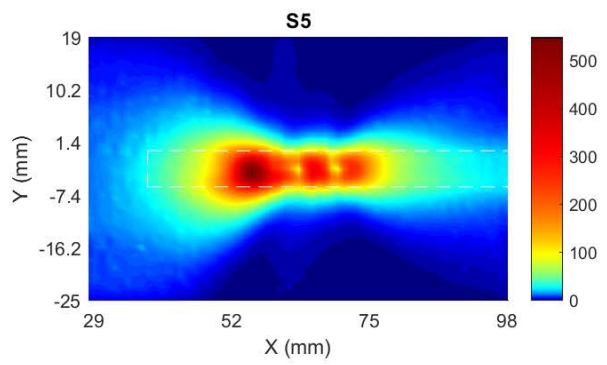
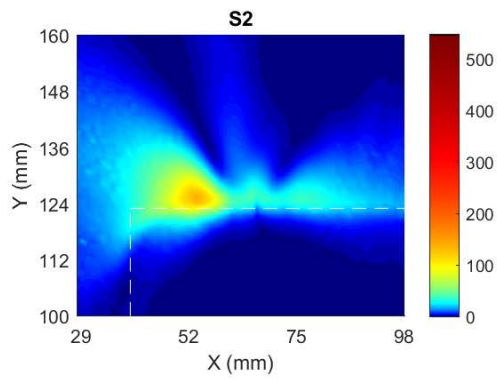
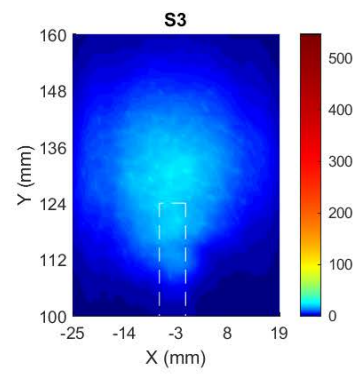
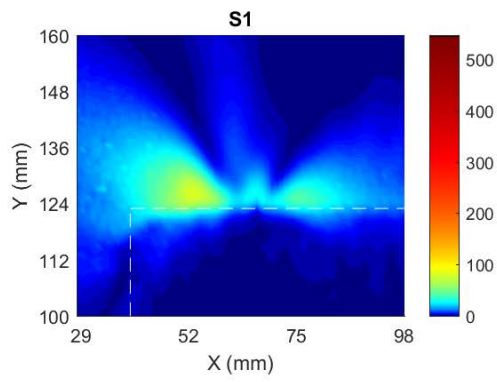



Module: Top Array, Band:n261, Power Density Plot for Beam ID:166

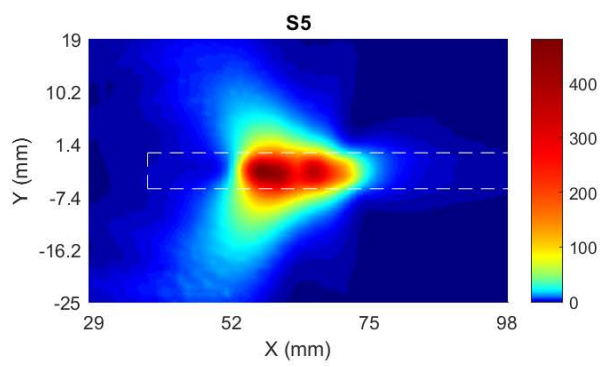
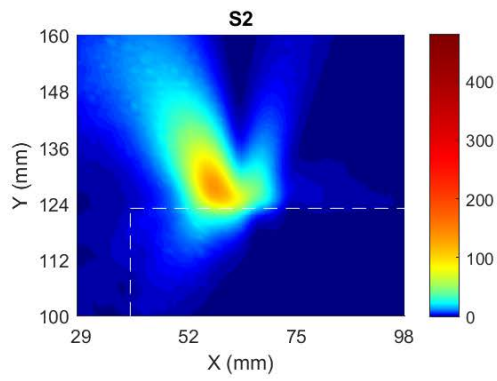
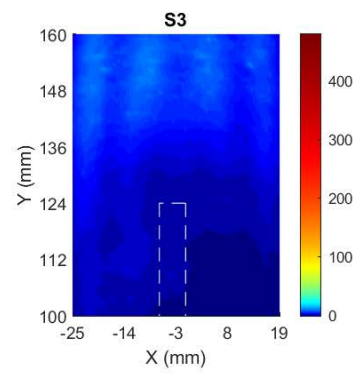
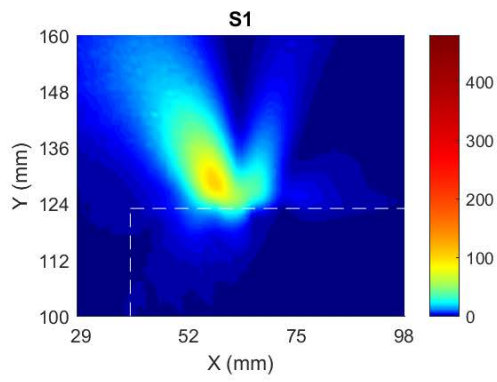



Module: Bottom Array, Band:n261, Power Density Plot for Beam ID:2

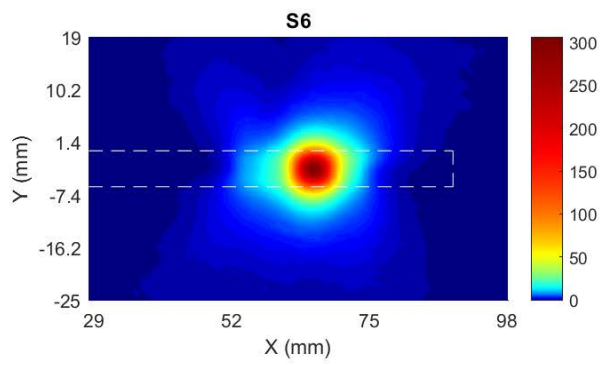
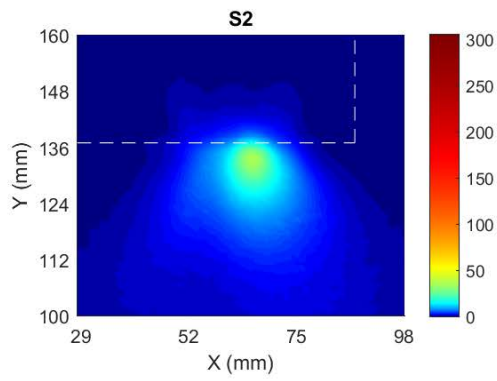
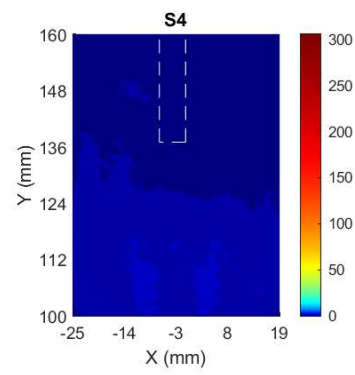
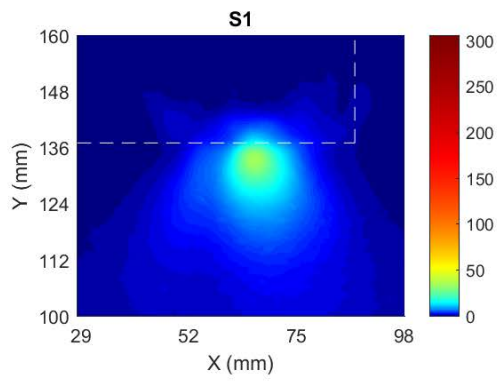



Module: Bottom Array, Band:n261, Power Density Plot for Beam ID:3

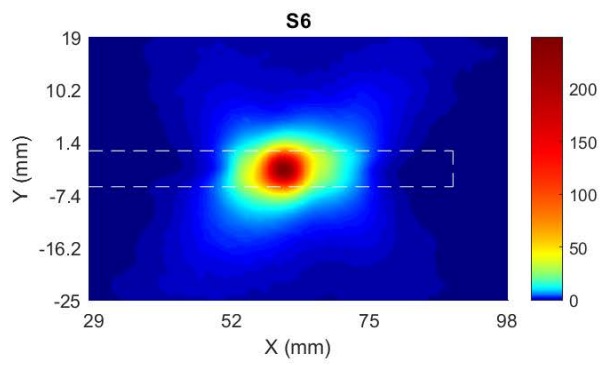
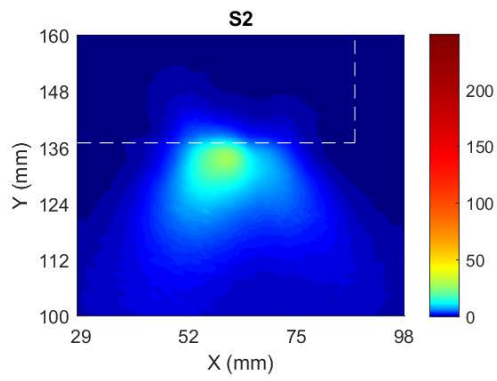
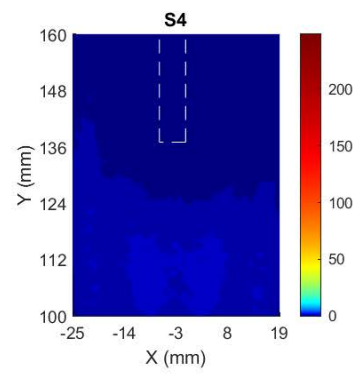
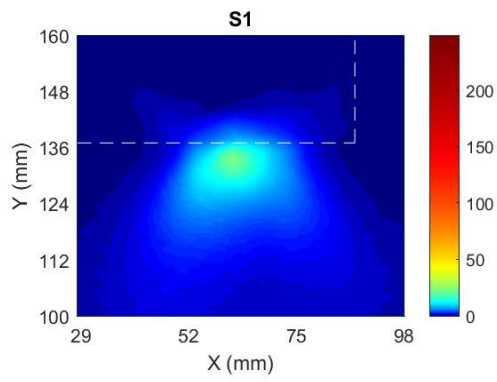



Module: Bottom Array, Band:n261, Power Density Plot for Beam ID:9

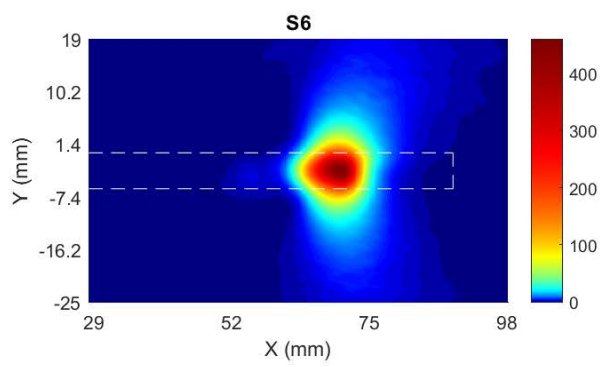
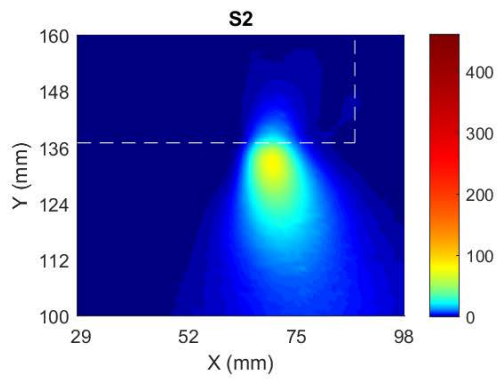
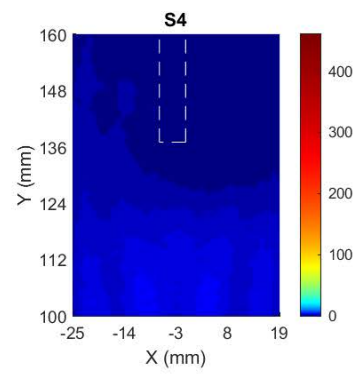
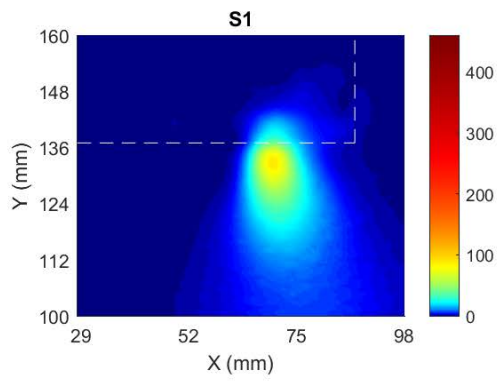



Module: Bottom Array, Band:n261, Power Density Plot for Beam ID:10

