



**FCC 47 CFR PART 15 SUBPART E
INDUSTRY CANADA RSS-247 ISSUE 1**

CERTIFICATION TEST REPORT

FOR

PORTABLE COMPUTER

MODEL NUMBER: A1707

FCC ID: BCGA1707

IC: 579C-A1707

REPORT NUMBER: 16U23800-E4V2

ISSUE DATE: OCTOBER 13, 2016

Prepared for

APPLE, INC.

1 INFINITE LOOP

CUPERTINO, CA 95014, U.S.A.

Prepared by

UL VERIFICATION SERVICES INC.

47173 BENICIA STREET

FREMONT, CA 94538, U.S.A.

TEL: (510) 771-1000

FAX: (510) 661-0888



NVLAP LAB CODE 200065-0

Revision History

<u>Rev.</u>	<u>Issue Date</u>	<u>Revisions</u>	<u>Revised By</u>
V1	09/28/2016	Initial Issue	MENGISTU MEKURIA
V2	10/13/2016	Updated Section 2 and 5.2 to address TCB's questions	Tina Chu

TABLE OF CONTENTS

1. ATTESTATION OF TEST RESULTS	12
2. TEST METHODOLOGY	13
3. FACILITIES AND ACCREDITATION	13
4. CALIBRATION AND UNCERTAINTY	14
4.1. MEASURING INSTRUMENT CALIBRATION	14
4.2. SAMPLE CALCULATION	14
4.3. MEASUREMENT UNCERTAINTY	14
5. EQUIPMENT UNDER TEST	15
5.1. DESCRIPTION OF EUT	15
5.2. MAXIMUM OUTPUT POWER	15
5.3. WORST-CASE CONFIGURATION AND MODE	17
5.4. DESCRIPTION OF AVAILABLE ANTENNAS	17
5.5. SOFTWARE AND FIRMWARE	17
5.6. DESCRIPTION OF TEST SETUP	18
6. TEST AND MEASUREMENT EQUIPMENT	23
7. ON TIME, DUTY CYCLE AND MEASUREMENT METHODS	24
7.1. ON TIME AND DUTY CYCLE	24
7.2. MEASUREMENT METHODS	36
8. ANTENNA PORT TEST RESULTS	37
8.1. 802.11n HT20 CHAIN 0 MODE IN THE 5.8 GHz BAND	37
8.1.1. 6 dB BANDWIDTH	37
8.1.2. 26 dB BANDWIDTH	40
8.1.3. 99% BANDWIDTH	43
8.1.4. AVERAGE POWER (FCC/IC)	46
8.1.5. OUTPUT POWER (FCC/IC)	47
8.1.6. PSD (FCC/IC)	49
8.2. 802.11n HT20 CHAIN 1 MODE IN THE 5.8 GHz BAND	53
8.2.1. 6 dB BANDWIDTH	53
8.2.2. 26 dB BANDWIDTH	56
8.2.3. 99% BANDWIDTH	59
8.2.4. AVERAGE POWER (FCC/IC)	62
8.2.5. OUTPUT POWER (FCC/IC)	63
8.2.6. PSD (FCC/IC)	65
8.3. 802.11n HT20 CHAIN 2 MODE IN THE 5.8 GHz BAND	69
8.3.1. 6 dB BANDWIDTH	69
8.3.2. 26 dB BANDWIDTH	72
8.3.3. 99% BANDWIDTH	75
8.3.4. AVERAGE POWER (FCC/IC)	78

8.3.5.	OUTPUT POWER (FCC/IC)	79
8.3.6.	PSD (FCC/IC).....	81
8.4.	<i>802.11n HT20 2Tx (CHAIN 0 + CHAIN 1) CDD MODE IN THE 5.8 GHz BAND</i>	<i>85</i>
8.4.1.	6 dB BANDWIDTH	85
8.4.2.	26 dB BANDWIDTH	89
8.4.3.	99% BANDWIDTH.....	93
8.4.4.	AVERAGE POWER (FCC/IC)	97
8.4.5.	OUTPUT POWER (FCC/IC)	98
8.4.6.	PSD (FCC/IC).....	100
8.5.	<i>802.11n HT20 2Tx (CHAIN 0 + CHAIN 2) CDD MODE IN THE 5.8 GHz BAND</i>	<i>105</i>
8.5.1.	6 dB BANDWIDTH	105
8.5.2.	26 dB BANDWIDTH	109
8.5.3.	99% BANDWIDTH.....	113
8.5.4.	AVERAGE POWER (FCC/IC)	117
8.5.5.	OUTPUT POWER (FCC/IC)	118
8.5.6.	PSD (FCC/IC).....	120
8.6.	<i>802.11n HT20 2Tx (CHAIN 1 + CHAIN 2) CDD MODE IN THE 5.8 GHz BAND</i>	<i>125</i>
8.6.1.	6 dB BANDWIDTH	125
8.6.2.	26 dB BANDWIDTH	129
8.6.3.	99% BANDWIDTH.....	133
8.6.4.	AVERAGE POWER (FCC/IC)	137
8.6.5.	OUTPUT POWER (FCC/IC)	138
8.6.6.	PSD (FCC/IC).....	140
8.7.	<i>802.11n HT20 2Tx (CHAIN 0 + CHAIN 1) STBC MODE IN THE 5.8 GHz BAND</i>	<i>145</i>
8.7.1.	6 dB BANDWIDTH	145
8.7.2.	26 dB BANDWIDTH	149
8.7.3.	99% BANDWIDTH.....	153
8.7.4.	AVERAGE POWER (FCC/IC)	157
8.7.5.	OUTPUT POWER (FCC/IC)	158
8.7.6.	PSD (FCC/IC).....	160
8.8.	<i>802.11n HT20 2Tx (CHAIN 0 + CHAIN 2) STBC MODE IN THE 5.8 GHz BAND</i>	<i>165</i>
8.8.1.	6 dB BANDWIDTH	165
8.8.2.	26 dB BANDWIDTH	169
8.8.3.	99% BANDWIDTH.....	173
8.8.4.	AVERAGE POWER (FCC/IC)	177
8.8.5.	OUTPUT POWER(FCC/IC)	178
8.8.6.	PSD (FCC/IC).....	180
8.9.	<i>802.11n HT20 2Tx (CHAIN 1 + CHAIN 2) STBC MODE IN THE 5.8 GHz BAND</i>	<i>185</i>
8.9.1.	6 dB BANDWIDTH	185
8.9.2.	26 dB BANDWIDTH	189
8.9.3.	99% BANDWIDTH.....	193
8.9.4.	AVERAGE POWER (FCC/IC)	197
8.9.5.	OUTPUT POWER (FCC/IC)	198
8.9.6.	PSD (FCC/IC).....	200
8.10.	<i>802.11ac VHT20 2Tx (CHAIN 0 + CHAIN 1) BEAM FORMING MODE IN THE 5.8 GHz BAND 205</i>	
8.10.1.	6 dB BANDWIDTH.....	205
8.10.2.	26 dB BANDWIDTH.....	209
8.10.3.	99% BANDWIDTH.....	213
8.10.4.	AVERAGE POWER (FCC)	217

8.10.5.	OUTPUT POWER (FCC).....	218
8.10.6.	PSD (FCC).....	220
8.10.7.	AVERAGE POWER (IC).....	225
8.10.8.	OUTPUT POWER (IC).....	226
8.10.9.	PSD (IC).....	228
8.11.	<i>802.11ac VHT20 2Tx (CHAIN 0 + CHAIN 2) BEAM FORMING MODE IN THE 5.8 GHz BAND 233</i>	
8.11.1.	6 dB BANDWIDTH.....	233
8.11.2.	26 dB BANDWIDTH.....	237
8.11.3.	99% BANDWIDTH.....	241
8.11.4.	AVERAGE POWER (FCC).....	245
8.11.5.	OUTPUT POWER (FCC).....	246
8.11.6.	PSD (FCC).....	248
8.11.7.	AVERAGE POWER (IC).....	253
8.11.8.	OUTPUT POWER (IC).....	254
8.11.9.	PSD (IC).....	256
8.12.	<i>802.11ac VHT20 2Tx (CHAIN 1 + CHAIN 2) BEAM FORMING MODE IN THE 5.8 GHz BAND 261</i>	
8.12.1.	6 dB BANDWIDTH.....	261
8.12.2.	26 dB BANDWIDTH.....	265
8.12.3.	99% BANDWIDTH.....	269
8.12.4.	AVERAGE POWER (FCC).....	273
8.12.5.	OUTPUT POWER (FCC).....	274
8.12.6.	PSD (FCC).....	276
8.12.7.	AVERAGE POWER (IC).....	281
8.12.8.	OUTPUT POWER (IC).....	282
8.12.9.	PSD (IC).....	284
8.13.	<i>802.11n HT20 3Tx CDD MODE IN THE 5.8 GHz BAND.....</i>	<i>289</i>
8.13.1.	6 dB BANDWIDTH.....	289
8.13.2.	26 dB BANDWIDTH.....	295
8.13.3.	99% BANDWIDTH.....	301
8.13.4.	AVERAGE POWER (FCC).....	307
8.13.5.	OUTPUT POWER (FCC).....	308
8.13.6.	PSD (FCC).....	310
8.13.7.	AVERAGE POWER (IC).....	317
8.13.8.	OUTPUT POWER (IC).....	318
8.13.9.	PSD (IC).....	320
8.14.	<i>802.11n HT20 3Tx STBC MODE IN THE 5.8 GHz BAND.....</i>	<i>327</i>
8.14.1.	6 dB BANDWIDTH.....	327
8.14.2.	26 dB BANDWIDTH.....	333
8.14.3.	99% BANDWIDTH.....	339
8.14.4.	AVERAGE POWER (FCC).....	345
8.14.5.	OUTPUT POWER (FCC).....	346
8.14.6.	PSD (FCC).....	348
8.14.7.	AVERAGE POWER (IC).....	355
8.14.8.	OUTPUT POWER (IC).....	356
8.14.9.	PSD (IC).....	358
8.15.	<i>802.11ac VHT20 3Tx BEAM FORMING MODE IN THE 5.8 GHz BAND.....</i>	<i>365</i>
8.15.1.	6 dB BANDWIDTH.....	365
8.15.2.	26 dB BANDWIDTH.....	371
8.15.3.	99% BANDWIDTH.....	377

8.15.4.	AVERAGE POWER (FCC)	383
8.15.5.	OUTPUT POWER (FCC)	384
8.15.6.	PSD (FCC).....	386
8.15.7.	AVERAGE POWER (IC)	393
8.15.8.	OUTPUT POWER (IC).....	394
8.15.9.	PSD (IC)	396
8.16.	<i>802.11n HT40 CHAIN 0 MODE IN THE 5.8 GHz BAND</i>	403
8.16.1.	6 dB BANDWIDTH.....	403
8.16.2.	26 dB BANDWIDTH.....	405
8.16.3.	99% BANDWIDTH	407
8.16.4.	AVERAGE POWER (FCC)	409
8.16.5.	OUTPUT POWER (FCC)	410
8.16.6.	PSD (FCC).....	412
8.16.7.	AVERAGE POWER (IC)	415
8.16.8.	OUTPUT POWER (IC).....	416
8.16.9.	PSD (IC)	418
8.17.	<i>802.11n HT40 CHAIN 1 MODE IN THE 5.8 GHz BAND</i>	421
8.17.1.	6 dB BANDWIDTH.....	421
8.17.2.	26 dB BANDWIDTH.....	423
8.17.3.	99% BANDWIDTH	425
8.17.4.	AVERAGE POWER (FCC)	427
8.17.5.	OUTPUT POWER (FCC)	428
8.17.6.	PSD (FCC).....	430
8.17.7.	AVERAGE POWER (IC)	433
8.17.8.	OUTPUT POWER (IC).....	434
8.17.9.	PSD (IC)	436
8.18.	<i>802.11n HT40 CHAIN 2 MODE IN THE 5.8 GHz BAND</i>	439
8.18.1.	6 dB BANDWIDTH.....	439
8.18.2.	26 dB BANDWIDTH.....	441
8.18.3.	99% BANDWIDTH	443
8.18.4.	AVERAGE POWER (FCC)	445
8.18.5.	OUTPUT POWER (FCC)	446
8.18.6.	PSD (FCC).....	448
8.18.7.	AVERAGE POWER (IC)	451
8.18.8.	OUTPUT POWER (IC).....	452
8.18.9.	PSD (IC)	454
8.19.	<i>802.11n HT40 2Tx (CHAIN 0 + CHAIN 1) CDD MODE IN THE 5.8 GHz BAND</i>	457
8.19.1.	6 dB BANDWIDTH.....	457
8.19.2.	26 dB BANDWIDTH.....	460
8.19.3.	99% BANDWIDTH	463
8.19.4.	AVERAGE POWER (FCC)	466
8.19.5.	OUTPUT POWER (FCC)	467
8.19.6.	PSD (FCC).....	469
8.19.7.	AVERAGE POWER (IC)	473
8.19.8.	OUTPUT POWER (IC).....	474
8.19.9.	PSD (IC)	476
8.20.	<i>802.11n HT40 2Tx (CHAIN 0 + CHAIN 2) CDD MODE IN THE 5.8 GHz BAND</i>	480
8.20.1.	6 dB BANDWIDTH.....	480
8.20.2.	26 dB BANDWIDTH.....	483
8.20.3.	99% BANDWIDTH	486
8.20.4.	AVERAGE POWER (FCC)	489

8.20.5.	OUTPUT POWER (FCC)	490
8.20.6.	PSD (FCC).....	492
8.20.7.	AVERAGE POWER (IC)	496
8.20.8.	OUTPUT POWER (IC).....	497
8.20.9.	PSD (IC)	499
8.21.	<i>802.11n HT40 2Tx (CHAIN 1 + CHAIN 2) CDD MODE IN THE 5.8 GHz BAND.....</i>	<i>503</i>
8.21.1.	6 dB BANDWIDTH.....	503
8.21.2.	26 dB BANDWIDTH.....	506
8.21.3.	99% BANDWIDTH.....	509
8.21.4.	AVERAGE POWER (FCC)	512
8.21.5.	OUTPUT POWER (FCC)	513
8.21.6.	PSD (FCC).....	515
8.21.7.	AVERAGE POWER (IC)	519
8.21.8.	OUTPUT POWER (IC).....	520
8.21.9.	PSD (IC)	522
8.22.	<i>802.11n HT40 2Tx (CHAIN 0 + CHAIN 1) STBC MODE IN THE 5.8 GHz BAND.....</i>	<i>526</i>
8.22.1.	6 dB BANDWIDTH.....	526
8.22.2.	26 dB BANDWIDTH.....	529
8.22.3.	99% BANDWIDTH.....	532
8.22.4.	AVERAGE POWER (FCC)	535
8.22.5.	OUTPUT POWER (FCC)	536
8.22.6.	PSD (FCC).....	538
8.22.7.	AVERAGE POWER (IC)	542
8.22.8.	OUTPUT POWER (IC).....	543
8.22.9.	PSD (IC)	545
8.23.	<i>802.11n HT40 2Tx (CHAIN 0 + CHAIN 2) STBC MODE IN THE 5.8 GHz BAND.....</i>	<i>549</i>
8.23.1.	6 dB BANDWIDTH.....	549
8.23.2.	26 dB BANDWIDTH.....	552
8.23.3.	99% BANDWIDTH.....	555
8.23.4.	AVERAGE POWER (FCC)	558
8.23.5.	OUTPUT POWER (FCC)	559
8.23.6.	PSD (FCC).....	561
8.23.7.	AVERAGE POWER (IC)	565
8.23.8.	OUTPUT POWER (IC).....	566
8.23.9.	PSD (IC)	568
8.24.	<i>802.11n HT40 2Tx (CHAIN 1 + CHAIN 2) STBC MODE IN THE 5.8 GHz BAND.....</i>	<i>572</i>
8.24.1.	6 dB BANDWIDTH.....	572
8.24.2.	26 dB BANDWIDTH.....	575
8.24.3.	99% BANDWIDTH.....	578
8.24.4.	AVERAGE POWER (FCC)	581
8.24.5.	OUTPUT POWER (FCC)	582
8.24.6.	PSD (FCC).....	584
8.24.1.	AVERAGE POWER (IC)	588
8.24.2.	OUTPUT POWER (IC).....	589
8.24.3.	PSD (IC)	591
8.25.	<i>802.11ac VHT40 2Tx (CHAIN 0 + CHAIN 1) BEAM FORMING MODE IN THE 5.8 GHz BAND 595</i>	
8.25.1.	6 dB BANDWIDTH.....	595
8.25.2.	26 dB BANDWIDTH.....	598
8.25.3.	99% BANDWIDTH.....	601
8.25.4.	AVERAGE POWER (FCC)	604

8.25.5.	OUTPUT POWER (FCC)	605
8.25.6.	PSD (FCC)	607
8.25.1.	AVERAGE POWER (IC)	611
8.25.2.	OUTPUT POWER (IC)	612
8.25.3.	PSD (IC)	614
8.26.	<i>802.11ac VHT40 2Tx (CHAIN 0 + CHAIN 2) BEAM FORMING MODE IN THE 5.8 GHz BAND 618</i>	
8.26.1.	6 dB BANDWIDTH	618
8.26.2.	26 dB BANDWIDTH	621
8.26.3.	99% BANDWIDTH	624
8.26.4.	AVERAGE POWER (FCC)	627
8.26.5.	OUTPUT POWER (FCC)	628
8.26.6.	PSD (FCC)	630
8.26.1.	AVERAGE POWER (IC)	634
8.26.2.	OUTPUT POWER (IC)	635
8.26.3.	PSD (IC)	637
8.27.	<i>802.11ac VHT40 2Tx (CHAIN 1 + CHAIN 2) BEAM FORMING MODE IN THE 5.8 GHz BAND 641</i>	
8.27.1.	6 dB BANDWIDTH	641
8.27.2.	26 dB BANDWIDTH	644
8.27.3.	99% BANDWIDTH	647
8.27.4.	AVERAGE POWER (FCC)	650
8.27.5.	OUTPUT POWER (FCC)	651
8.27.6.	PSD (FCC)	653
8.27.1.	AVERAGE POWER (IC)	657
8.27.2.	OUTPUT POWER (IC)	658
8.27.3.	PSD (IC)	660
8.28.	<i>802.11n HT40 3Tx CDD MODE IN THE 5.8 GHz BAND</i>	664
8.28.1.	6 dB BANDWIDTH	664
8.28.2.	26 dB BANDWIDTH	668
8.28.3.	99% BANDWIDTH	672
8.28.4.	AVERAGE POWER (FCC)	676
8.28.5.	OUTPUT POWER (FCC)	677
8.28.6.	PSD (FCC)	679
8.28.1.	AVERAGE POWER (IC)	684
8.28.2.	OUTPUT POWER (IC)	685
8.28.3.	PSD (IC)	687
8.29.	<i>802.11n HT40 3Tx STBC MODE IN THE 5.8 GHz BAND</i>	692
8.29.1.	6 dB BANDWIDTH	692
8.29.2.	26 dB BANDWIDTH	696
8.29.3.	99% BANDWIDTH	700
8.29.4.	AVERAGE POWER (FCC)	704
8.29.5.	OUTPUT POWER (FCC)	705
8.29.6.	PSD (FCC)	707
8.29.1.	AVERAGE POWER (IC)	712
8.29.2.	OUTPUT POWER (IC)	713
8.29.3.	PSD (IC)	715
8.30.	<i>802.11ac VHT40 3Tx BEAM FORMING MODE IN THE 5.8 GHz BAND</i>	720
8.30.1.	6 dB BANDWIDTH	720
8.30.2.	26 dB BANDWIDTH	724
8.30.3.	99% BANDWIDTH	728

8.30.4.	AVERAGE POWER (FCC)	732
8.30.5.	OUTPUT POWER (FCC)	733
8.30.6.	PSD (FCC).....	735
8.30.1.	AVERAGE POWER (IC)	740
8.30.2.	OUTPUT POWER (IC).....	741
8.30.3.	PSD (IC)	743
8.31.	<i>802.11ac VHT80 CHAIN 0 MODE IN THE 5.8 GHz BAND</i>	748
8.31.1.	6 dB BANDWIDTH.....	748
8.31.2.	26 dB BANDWIDTH.....	749
8.31.3.	99% BANDWIDTH	750
8.31.4.	AVERAGE POWER (FCC/IC)	751
8.31.5.	OUTPUT POWER (FCC/IC)	752
8.31.6.	PSD (FCC/IC)	754
8.32.	<i>802.11ac VHT80 CHAIN 1 MODE IN THE 5.8 GHz BAND</i>	756
8.32.1.	6 dB BANDWIDTH.....	756
8.32.2.	26 dB BANDWIDTH.....	757
8.32.3.	99% BANDWIDTH	758
8.32.4.	AVERAGE POWER (FCC/IC)	759
8.32.5.	OUTPUT POWER (FCC/IC)	760
8.32.6.	PSD (FCC/IC)	762
8.33.	<i>802.11ac VHT80 CHAIN 2 MODE IN THE 5.8 GHz BAND</i>	764
8.33.1.	6 dB BANDWIDTH.....	764
8.33.2.	26 dB BANDWIDTH.....	765
8.33.3.	99% BANDWIDTH	766
8.33.4.	AVERAGE POWER (FCC/IC)	767
8.33.5.	OUTPUT POWER (FCC/IC)	768
8.33.6.	PSD (FCC/IC)	770
8.34.	<i>802.11ac VHT80 2Tx (CHAIN 0 + CHAIN 1) CDD MODE IN THE 5.8 GHz BAND</i>	772
8.34.1.	6 dB BANDWIDTH.....	772
8.34.2.	26 dB BANDWIDTH.....	774
8.34.3.	99% BANDWIDTH	776
8.34.4.	AVERAGE POWER (FCC)	778
8.34.5.	OUTPUT POWER (FCC)	779
8.34.6.	PSD (FCC).....	781
8.34.7.	AVERAGE POWER (IC)	784
8.34.8.	OUTPUT POWER (IC).....	785
8.34.9.	PSD (IC)	787
8.35.	<i>802.11ac VHT80 2Tx (CHAIN 0 + CHAIN 2) CDD MODE IN THE 5.8 GHz BAND</i>	790
8.35.1.	6 dB BANDWIDTH.....	790
8.35.2.	26 dB BANDWIDTH.....	792
8.35.3.	99% BANDWIDTH	794
8.35.4.	AVERAGE POWER (FCC)	796
8.35.5.	OUTPUT POWER (FCC)	797
8.35.6.	PSD (FCC).....	799
8.35.7.	AVERAGE POWER (IC)	802
8.35.8.	OUTPUT POWER (IC).....	803
8.35.9.	PSD (IC)	805
8.36.	<i>802.11ac VHT80 2Tx (CHAIN 1 + CHAIN 2) CDD MODE IN THE 5.8 GHz BAND</i>	808
8.36.1.	6 dB BANDWIDTH.....	808
8.36.2.	26 dB BANDWIDTH.....	810

8.36.3.	99% BANDWIDTH.....	812
8.36.4.	AVERAGE POWER (FCC).....	814
8.36.5.	OUTPUT POWER (FCC).....	815
8.36.6.	PSD (FCC).....	817
8.36.7.	AVERAGE POWER (IC).....	820
8.36.8.	OUTPUT POWER (IC).....	821
8.36.9.	PSD (IC).....	823
8.37.	<i>802.11ac VHT80 2Tx (CHAIN 0 + CHAIN 1) STBC MODE IN THE 5.8 GHz BAND.....</i>	<i>826</i>
8.37.1.	6 dB BANDWIDTH.....	826
8.37.2.	26 dB BANDWIDTH.....	828
8.37.3.	99% BANDWIDTH.....	830
8.37.4.	AVERAGE POWER (FCC).....	832
8.37.5.	OUTPUT POWER (FCC).....	833
8.37.6.	PSD (FCC).....	835
8.37.7.	AVERAGE POWER (IC).....	838
8.37.8.	OUTPUT POWER (IC).....	839
8.37.9.	PSD (IC).....	841
8.38.	<i>802.11ac VHT80 2Tx (CHAIN 0 + CHAIN 2) STBC MODE IN THE 5.8 GHz BAND.....</i>	<i>844</i>
8.38.1.	6 dB BANDWIDTH.....	844
8.38.2.	26 dB BANDWIDTH.....	846
8.38.3.	99% BANDWIDTH.....	848
8.38.4.	AVERAGE POWER (FCC).....	850
8.38.5.	OUTPUT POWER (FCC).....	851
8.38.6.	PSD (FCC).....	853
8.38.7.	AVERAGE POWER (IC).....	856
8.38.8.	OUTPUT POWER (IC).....	857
8.38.9.	PSD (IC).....	859
8.39.	<i>802.11ac VHT80 2Tx (CHAIN 1 + CHAIN 2) STBC MODE IN THE 5.8 GHz BAND.....</i>	<i>862</i>
8.39.1.	6 dB BANDWIDTH.....	862
8.39.2.	26 dB BANDWIDTH.....	864
8.39.3.	99% BANDWIDTH.....	866
8.39.4.	AVERAGE POWER (FCC).....	868
8.39.5.	OUTPUT POWER (FCC).....	869
8.39.6.	PSD (FCC).....	871
8.39.7.	AVERAGE POWER (IC).....	874
8.39.8.	OUTPUT POWER (IC).....	875
8.39.9.	PSD (IC).....	877
8.40.	<i>802.11ac VHT80 2Tx (CHAIN 0 + CHAIN 1) BEAM FORMING MODE IN THE 5.8 GHz BAND 880</i>	
8.40.1.	6 dB BANDWIDTH.....	880
8.40.2.	26 dB BANDWIDTH.....	882
8.40.3.	99% BANDWIDTH.....	884
8.40.4.	AVERAGE POWER (FCC).....	886
8.40.5.	OUTPUT POWER (FCC).....	887
8.40.6.	PSD (FCC).....	889
8.40.7.	AVERAGE POWER (IC).....	892
8.40.8.	OUTPUT POWER (IC).....	893
8.40.9.	PSD (IC).....	895
8.41.	<i>802.11ac VHT80 2Tx (CHAIN 0 + CHAIN 2) BEAM FORMING MODE IN THE 5.8 GHz BAND 898</i>	
8.41.1.	6 dB BANDWIDTH.....	898

8.41.2.	26 dB BANDWIDTH.....	900
8.41.3.	99% BANDWIDTH.....	902
8.41.4.	AVERAGE POWER (FCC)	904
8.41.5.	OUTPUT POWER (FCC)	905
8.41.6.	PSD (FCC).....	907
8.41.7.	AVERAGE POWER (IC)	910
8.41.8.	OUTPUT POWER (IC).....	911
8.41.9.	PSD (IC)	913
8.42.	<i>802.11ac VHT80 2Tx (CHAIN 1 + CHAIN 2) BEAM FORMING MODE IN THE 5.8 GHz BAND 916</i>	
8.42.1.	6 dB BANDWIDTH.....	916
8.42.2.	26 dB BANDWIDTH.....	918
8.42.3.	99% BANDWIDTH.....	920
8.42.4.	AVERAGE POWER (FCC)	922
8.42.5.	OUTPUT POWER (FCC)	923
8.42.6.	PSD (FCC).....	925
8.42.7.	AVERAGE POWER (IC)	928
8.42.8.	OUTPUT POWER (IC).....	929
8.42.9.	PSD (IC)	931
8.43.	<i>802.11ac VHT80 3Tx CDD MODE IN THE 5.8 GHz BAND.....</i>	<i>934</i>
8.43.1.	6 dB BANDWIDTH.....	934
8.43.2.	26 dB BANDWIDTH.....	937
8.43.3.	99% BANDWIDTH.....	940
8.43.4.	AVERAGE POWER (FCC)	943
8.43.5.	OUTPUT POWER (FCC)	944
8.43.6.	PSD (FCC).....	946
8.43.7.	AVERAGE POWER (IC)	950
8.43.8.	OUTPUT POWER (IC).....	951
8.43.9.	PSD (IC)	953
8.44.	<i>802.11ac VHT80 3Tx STBC MODE IN THE 5.8 GHz BAND.....</i>	<i>957</i>
8.44.1.	6 dB BANDWIDTH.....	957
8.44.2.	26 dB BANDWIDTH.....	960
8.44.3.	99% BANDWIDTH.....	963
8.44.4.	AVERAGE POWER (FCC)	966
8.44.5.	OUTPUT POWER (FCC)	967
8.44.6.	PSD (FCC).....	969
8.44.7.	AVERAGE POWER (IC)	973
8.44.8.	OUTPUT POWER (IC).....	974
8.44.9.	PSD (IC)	976
8.45.	<i>802.11ac VHT80 3Tx BEAM FORMING MODE IN THE 5.8 GHz BAND.....</i>	<i>980</i>
8.45.1.	6 dB BANDWIDTH.....	980
8.45.2.	26 dB BANDWIDTH.....	983
8.45.3.	99% BANDWIDTH.....	986
8.45.4.	AVERAGE POWER (FCC)	989
8.45.5.	OUTPUT POWER (FCC)	990
8.45.6.	PSD (FCC).....	992
8.45.7.	AVERAGE POWER (IC)	996
8.45.8.	OUTPUT POWER (IC).....	997
8.45.9.	PSD (IC)	999

1. ATTESTATION OF TEST RESULTS

COMPANY NAME: APPLE, INC.
1 INFINITE LOOP
CUPERTINO, CA 95014, U.S.A.

EUT DESCRIPTION: PORTABLE COMPUTER

MODEL: A1707

SERIAL NUMBER: C02S3004H7CF (CONDUCTED);
C02S400FH7C9 (RADIATED/DFS)

DATE TESTED: AUGUST 02, 2016- SEPTEMBER 19, 2016

APPLICABLE STANDARDS	
STANDARD	TEST RESULTS
CFR 47 Part 15 Subpart E	Pass
INDUSTRY CANADA RSS-247 Issue 1	Pass
INDUSTRY CANADA RSS-GEN Issue 4	Pass

UL Verification Services Inc. tested the above equipment in accordance with the requirements set forth in the above standards. All indications of Pass/Fail in this report are opinions expressed by UL Verification Services Inc. based on interpretations and/or observations of test results. Measurement Uncertainties were not taken into account and are published for informational purposes only. The test results show that the equipment tested is capable of demonstrating compliance with the requirements as documented in this report.

Note: The results documented in this report apply only to the tested sample, under the conditions and modes of operation as described herein. This document may not be altered or revised in any way unless done so by UL Verification Services Inc. and all revisions are duly noted in the revisions section. Any alteration of this document not carried out by UL Verification Services Inc. will constitute fraud and shall nullify the document. This report must not be used by the client to claim product certification, approval, or endorsement by NVLAP, NIST, any agency of the Federal Government, or any agency of any government.

Approved & Released For
UL Verification Services Inc. By:

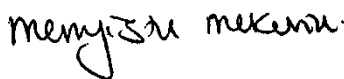

MENGISTU MEKURIA
SENIOR ENGINEER
UL VERIFICATION SERVICES INC.

Prepared By:



ERIC YU
EMC LAB ENGINEER
UL VERIFICATION SERVICES INC.

2. TEST METHODOLOGY

FCC: The tests documented in this report were performed in accordance with FCC CFR 47 Part 2, FCC CFR 47 Part 15, FCC 14-30, FCC KDB 662911 D01 v02r01, FCC KDB 905462 D02 v02/D03 v01r01/D06 v02/ D07 v01r01, FCC KDB 789033 D02 v01r03, FCC KDB 644545 D03 v01, ANSI C63.10-2013.

IC: The tests documented in this report were performed in accordance with FCC KDB 789033 D02 v01r03, FCC KDB 905462 D02 v02/D03 v01r01, ANSI C63.10-2013, RSS-GEN Issue 4, and RSS-247 Issue 1

3. FACILITIES AND ACCREDITATION

The test sites and measurement facilities used to collect data are located at 47173 and 47266 Benicia Street, Fremont, California, USA. Line conducted emissions are measured only at the 47173 address. The following table identifies which facilities were utilized for radiated emission measurements documented in this report. Specific facilities are also identified in the test results sections.

47173 Benicia Street	47266 Benicia Street
<input type="checkbox"/> Chamber A	<input checked="" type="checkbox"/> Chamber D
<input type="checkbox"/> Chamber B	<input checked="" type="checkbox"/> Chamber E
<input type="checkbox"/> Chamber C	<input type="checkbox"/> Chamber F
	<input checked="" type="checkbox"/> Chamber G
	<input checked="" type="checkbox"/> Chamber H

The above test sites and facilities are covered under FCC Test Firm Registration # 208313. Chambers A through H are covered under Industry Canada company address code 2324B with site numbers 2324B -1 through 2324B-8, respectively.

UL Verification Services Inc. is accredited by NVLAP, Laboratory Code 200065-0. The full scope of accreditation can be viewed at <http://ts.nist.gov/standards/scopes/2000650.htm>.

4. CALIBRATION AND UNCERTAINTY

4.1. MEASURING INSTRUMENT CALIBRATION

The measuring equipment utilized to perform the tests documented in this report has been calibrated in accordance with the manufacturer's recommendations, and is traceable to recognized national standards.

4.2. SAMPLE CALCULATION

Where relevant, the following sample calculation is provided:

$$\begin{aligned} \text{Field Strength (dBuV/m)} &= \text{Measured Voltage (dBuV)} + \text{Antenna Factor (dB/m)} + \text{Cable} \\ &\text{Loss (dB)} - \text{Preamp Gain (dB)} \\ 36.5 \text{ dBuV} + 18.7 \text{ dB/m} + 0.6 \text{ dB} - 26.9 \text{ dB} &= 28.9 \text{ dBuV/m} \end{aligned}$$

4.3. MEASUREMENT UNCERTAINTY

Where relevant, the following measurement uncertainty levels have been estimated for tests performed on the apparatus:

PARAMETER	UNCERTAINTY
Conducted Disturbance, 9KHz to 0.15 MHz	3.84 dB
Conducted Disturbance, 0.15 to 30 MHz	3.65 dB
Radiated Disturbance, 9KHz to 30 MHz	3.15 dB
Radiated Disturbance, 30 to 1000 MHz	5.36 dB
Radiated Disturbance, 1000 to 18000 MHz	4.32 dB
Radiated Disturbance, 18000 to 26000 MHz	4.45 dB
Radiated Disturbance, 26000 to 40000 MHz	5.24 dB

Uncertainty figures are valid to a confidence level of 95%.

5. EQUIPMENT UNDER TEST

5.1. DESCRIPTION OF EUT

The EUT is a portable computer with Bluetooth and WLAN Radios (AC 80 MHz Beam Forming).

5.2. MAXIMUM OUTPUT POWER

The transmitter has a maximum average conducted output power as follows:

5.8GHz Band FCC

Frequency Range (MHz)	Mode	Output Power (dBm)	Output Power (mW)
5745 - 5825	802.11a	Covered by 802.11n HT20 SISO	
	802.11n HT20 SISO	12.73	18.75
	802.11a 2TX CDD	Covered by 802.11n HT20 CDD	
	802.11n HT20 2TX CDD	15.70	37.15
	802.11n HT20 2TX STBC/SDM	15.73	37.41
	802.11ac VHT20 2TX Beam Forming	15.72	37.33
	802.11n HT20 3TX CDD	17.51	56.36
	802.11n HT20 3TX STBC/SDM	17.49	56.10
5755 - 5795	802.11ac VHT20 3TX Beam Forming	17.47	55.85
	802.11n HT40 SISO	17.97	62.66
	802.11n HT40 2TX CDD	15.74	37.50
	802.11n HT40 2TX STBC/SDM	15.73	37.41
	802.11ac VHT40 2TX Beam Forming	15.76	37.67
	802.11n HT40 3TX CDD	17.46	55.72
	802.11n HT40 3TX STBC/SDM	17.47	55.85
5775	802.11ac VHT40 3TX Beam Forming	17.44	55.46
	802.11ac VHT80 SISO	12.71	18.66
	802.11ac VHT80 2TX CDD	15.73	37.41
	802.11ac VHT80 2TX STBC/SDM	15.69	37.07
	802.11ac VHT80 2TX Beam Forming	15.71	37.24
	802.11ac VHT80 3TX CDD	17.47	55.85
	802.11ac VHT80 3TX STBC/SDM	17.47	55.85
	802.11ac VHT803TX Beam Forming	17.34	54.20

5.8GHz Band IC

Frequency Range (MHz)	Mode	Output Power (dBm)	Output Power (mW)
5745 - 5825	802.11a	Covered by 802.11n HT20 SISO	
	802.11n HT20 SISO	12.73	18.75
	802.11a 2TX CDD	Covered by 802.11n HT20 CDD	
	802.11n HT20 2TX CDD	15.70	37.15
	802.11n HT20 2TX STBC/SDM	15.73	37.41
	802.11ac VHT20 2TX Beam Forming	15.70	37.15
	802.11n HT20 3TX CDD	17.51	56.36
	802.11n HT20 3TX STBC/SDM	17.48	55.98
5755 - 5795	802.11ac VHT20 3TX Beam Forming	17.47	55.85
	802.11n HT40 SISO	12.75	18.84
	802.11n HT40 2TX CDD	15.74	37.50
	802.11n HT40 2TX STBC/SDM	14.47	27.99
	802.11ac VHT40 2TX Beam Forming	15.74	37.50
	802.11n HT40 3TX CDD	17.46	55.72
	802.11n HT40 3TX STBC/SDM	17.44	55.46
5775	802.11ac VHT40 3TX Beam Forming	17.36	54.45
	802.11ac VHT80 SISO	12.71	18.66
	802.11ac VHT80 2TX CDD	13.48	22.28
	802.11ac VHT80 2TX STBC/SDM	13.47	22.23
	802.11ac VHT80 2TX Beam Forming	10.98	12.53
	802.11ac VHT80 3TX CDD	12.20	16.60
	802.11ac VHT80 3TX STBC/SDM	15.20	33.11
	802.11ac VHT803TX Beam Forming	12.23	16.71

5.3. WORST-CASE CONFIGURATION AND MODE

For radiated harmonics spurious and power line conducted emissions were performed with the EUT set at the CDD mode at highest power setting among the CDD/STBC/SDM/Beamforming modes as worst-case scenario.

For SISO modes, there are three transmission antennas. The antenna used in any given time can be either Chain 0, Chain 1 or Chain 2. All antenna ports have the same power; output power and PSD measurement for SISO modes on both antennas are reported. For 2TX MIMO modes, Chain 0/Chain 1, Chain 0/Chain 2, Chain 1/Chain 2 used at the same time. For 3TX MIMO mode, Chain 0/Chain 1/Chain 2 used at the same time.

Worst-case data rates as provided by the client were:

- 802.11a mode: 6 Mbps
- 802.11n HT20 mode: MCS0
- 802.11n HT40 mode: MCS0
- 802.11ac VHT20 mode: MCS0
- 802.11ac VHT40 mode: MCS0
- 802.11ac VHT80 mode: MCS0

802.11ac VHT20 and VHT40 mode are different from 802.11nHT20 and HT40 only in control messages and have the same power settings.

For simultaneous transmission of multiple channels from the same antenna in the 2.4GHz and 5GHz bands, tests were conducted for various configurations having the highest power. No noticeable new emission was found.

5.4. DESCRIPTION OF AVAILABLE ANTENNAS

Frequency Band (GHz)	Antenna Gain (dBi)		
	Chain 0	Chain 1	Chain 2
5.8	4.00	6.30	4.70

5.5. SOFTWARE AND FIRMWARE

The firmware version installed in the EUT during testing was 7.21.170.1.

5.6. DESCRIPTION OF TEST SETUP

SUPPORT EQUIPMENT

Support Equipment List				
Description	Manufacturer	Model	Serial Number	FCC ID
AC/ DC Adapter	Apple Inc.	A1540	N/A	N/A

I/O CABLES (CONDUCTED TEST)

I/O Cable List						
Cable No	Port	# of identical ports	Connector Type	Cable Type	Cable Length (m)	Remarks
1	Antenna	2	SMA	Un-Shielded	0.2	To Spectrum Analyzer
2	DC	1	Lightning	Un-Shielded	2	N/A

I/O CABLES (ABOVE 1G RADIATED TEST)

I/O Cable List						
Cable No	Port	# of identical ports	Connector Type	Cable Type	Cable Length (m)	Remarks
1	DC	1	Lightning	Un-Shielded	2	N/A

I/O CABLES (BELOW 1G RADIATED AND AC POWER CONDUCTED TEST)

I/O Cable List						
Cable No	Port	# of identical ports	Connector Type	Cable Type	Cable Length (m)	Remarks
1	DC	1	Lightning	Un-Shielded	2	NA
2	Audio	1	Jack	Un-Shielded	0.5	NA

TEST SETUP- CONDUCTED PORT

The EUT was tested connected to spectrum analyzer via antenna port. Test software exercised the EUT.

SETUP DIAGRAM

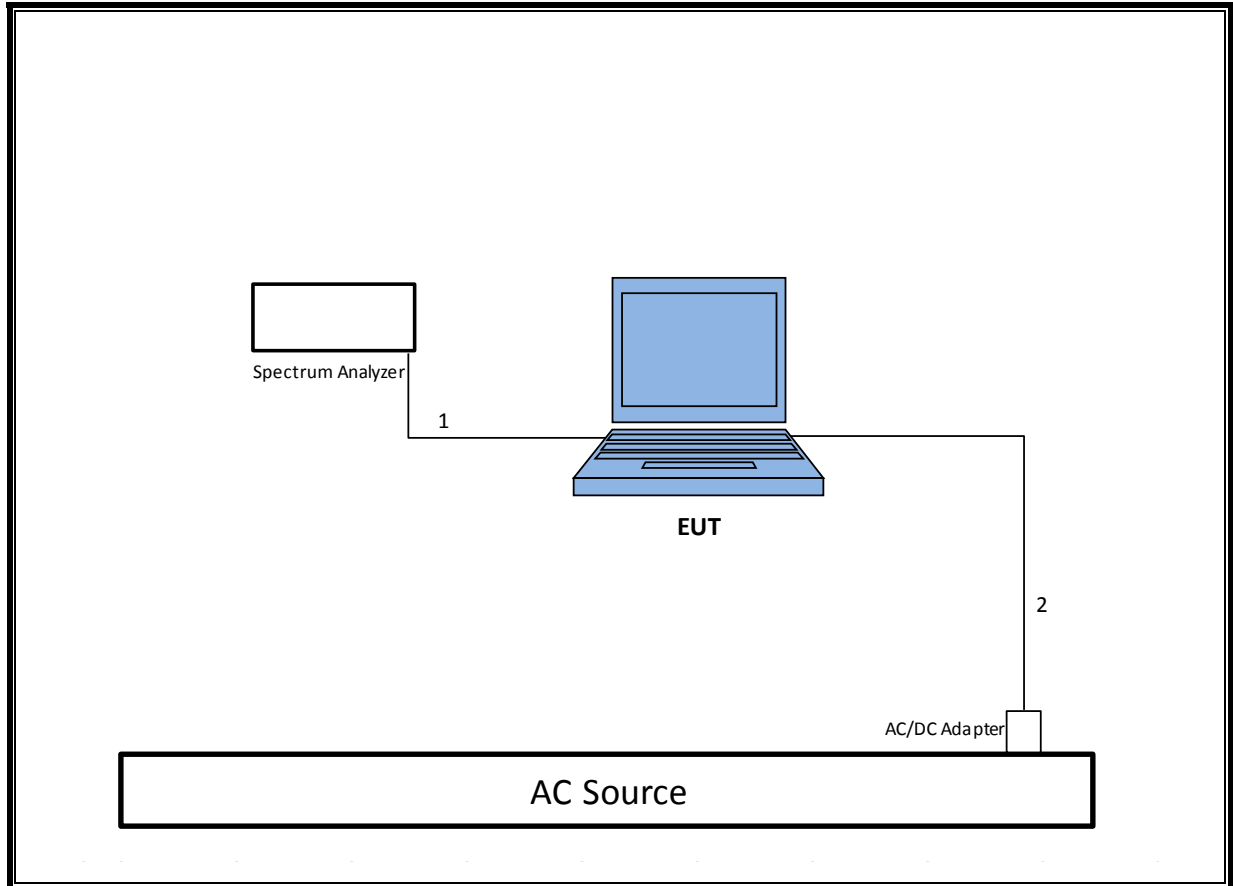

TEST SETUP- RADIATED- ABOVE 1 GHz

The EUT was powered by AC/DC adapter. Test software exercised the EUT.

SETUP DIAGRAM

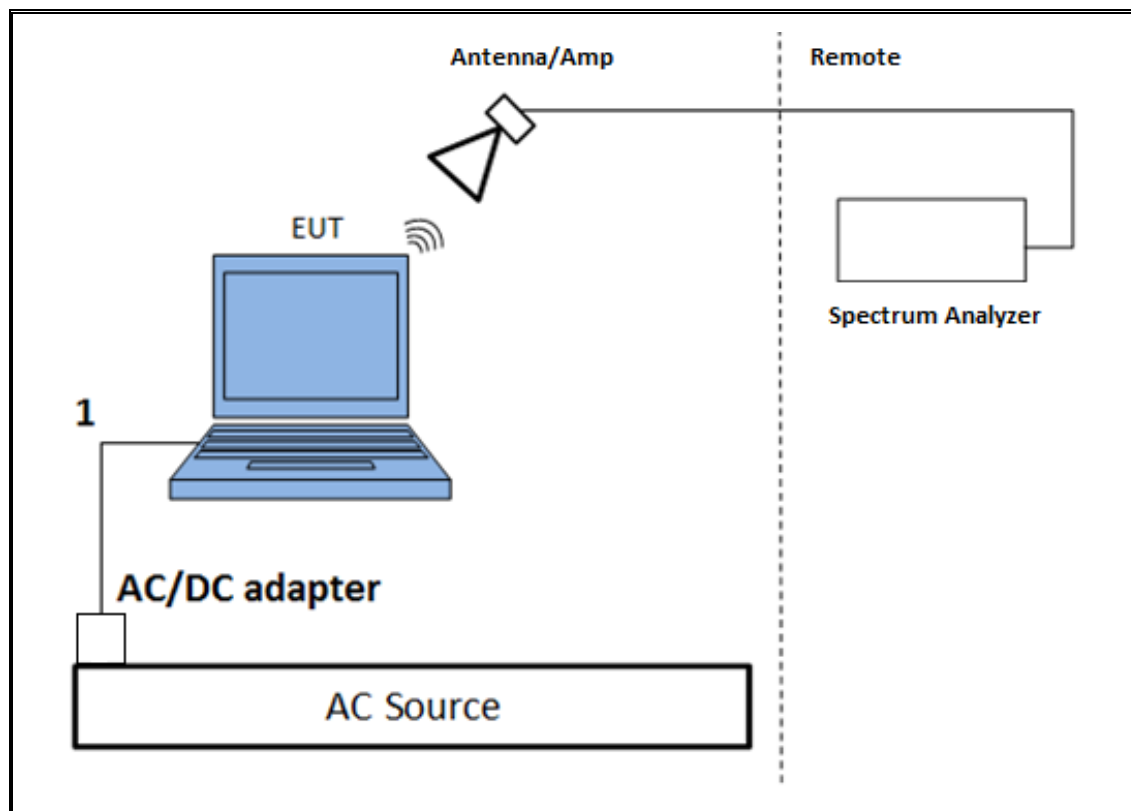

TEST SETUP- RADIATED- BELOW 1 GHz

The EUT was powered by AC/DC adapter and with earphone plugged in. Test software exercised the EUT.

SETUP DIAGRAM

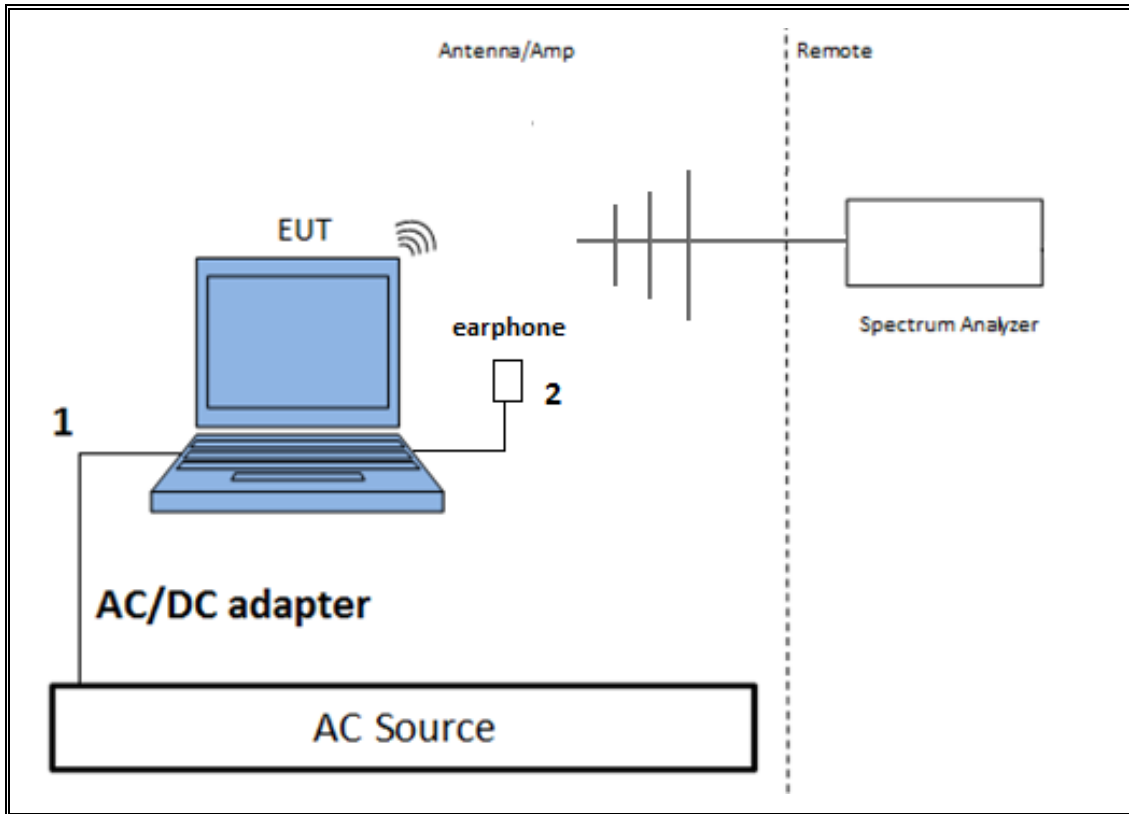

TEST SETUP- AC LINE CONDUCTED TESTS

The EUT was powered by AC/DC adapter and with earphone plugged in. Test software exercised the EUT.

SETUP DIAGRAM

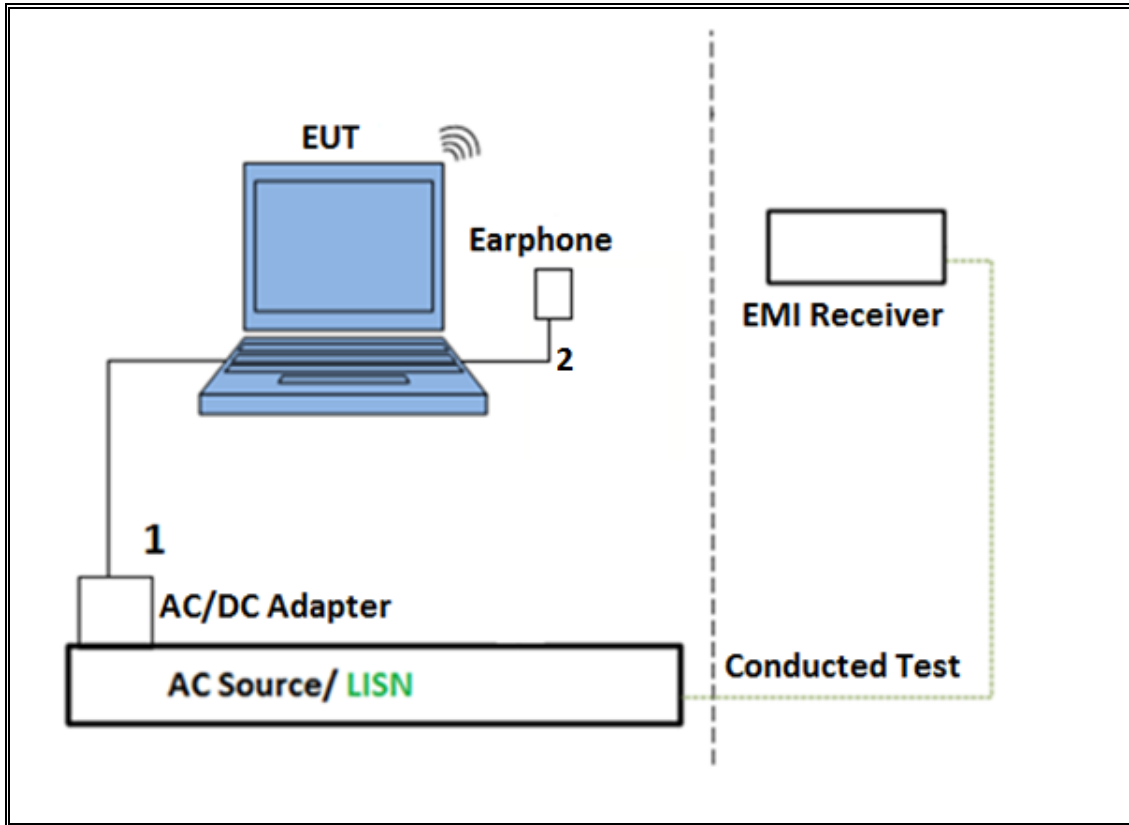

6. TEST AND MEASUREMENT EQUIPMENT

The following test and measurement equipment was utilized for the tests documented in this report:

Test Equipment List				
Description	Manufacturer	Model	T Number	Cal Due
Antenna, Horn 1-18GHz	ETS Lindgren	3117	T120	4/5/2017
Antenna, Broadband Hybrid, 30MHz to 2000MHz	Sunol Sciences	JB3	T122	1/29/2017
Amplifier, 10KHz to 1GHz, 32dB	Sonoma	310N	T173	6/17/2017
Spectrum Analyzer, PXA, 3Hz to 44GHz	Agilent	N9030A	T341	10/14/2016
Antenna, Horn 1-18GHz	ETS Lindgren	3117	T862	4/18/2017
Antenna, Broadband Hybrid, 30MHz to 2000MHz	Sunol Sciences	JB3	T899	5/26/2017
Amplifier, 1 - 18GHz	Miteq	AFS42-00101800-25-S-42	T491	5/31/2017
Amplifier, 10KHz to 1GHz, 32dB	Sonoma	310N	T834	6/17/2017
Spectrum Analyzer, PXA, 3Hz to 44GHz	Agilent	N9030A	T905	6/21/2017
Power Meter, P-series single channel	Agilent	N1911A	T1271	7/8/2017
Power Sensor, P - series, 50MHz to 18GHz, Wideband	Agilent	N1921A	T1228	6/20/2017
Antenna, Horn 18 to 26.5GHz	ARA	MWH-1826	T447	6/16/2017
***Spectrum Analyzer, 40 GHz	Agilent	8564E	T106	9/7/2017
Amplifier, 1 to 26.5GHz, 23.5dB Gain minimum	Keysight	8449B	T402	7/5/2017
AC Line Conducted				
EMI Test Receiver 9KHz-7GHz	Rohde & Schwarz	ESCI7	T1436	12/19/2016
LISN for Conducted Emissions CISPR-16	Fischer	50/250-25-2-01	T1310	6/8/2017
**AC Source	Shaffner	NSG 1007	T134	9/11/2016
UL SOFTWARE				
* Radiated Software	UL	UL EMC	Ver 9.5, June 24, 2015	
* Conducted Software	UL	UL EMC	Ver 4.0, January 11, 2016	
* AC Line Conducted Software	UL	UL EMC	Ver 9.5, May 26, 2015	

Note: * indicates automation software version used in the compliance certification testing

** equipment was used before calibration due date.

*** equipment was used after calibration.

7. ON TIME, DUTY CYCLE AND MEASUREMENT METHODS

7.1. ON TIME AND DUTY CYCLE

LIMITS

None; for reporting purposes only.

PROCEDURE

KDB 789033 Zero-Span Spectrum Analyzer Method.

RESULTS

Mode	ON Time B (msec)	Period (msec)	Duty Cycle x (linear)	Duty Cycle (%)	Duty Cycle Correction Factor (dB)	1/B Minimum VBW (kHz)
802.11n HT20 1TX	1.911	1.929	0.991	99.07%	0.00	0.010
802.11n HT20 CDD 2TX	1.917	1.938	0.989	98.92%	0.00	0.010
802.11n HT20 CDD 3TX	2.290	2.311	0.991	99.09%	0.00	0.010
802.11n HT20 STBC/SDM 2TX	2.289	2.307	0.992	99.22%	0.00	0.010
802.11n HT20 STBC/SDM 3TX	2.286	2.314	0.988	98.79%	0.00	0.010
802.11n HT20 BF 2TX	1.996	2.544	0.785	78.47%	1.05	0.501
802.11n HT20 BF 3TX	1.993	2.338	0.853	85.26%	0.69	0.502
802.11n HT40 1TX	1.122	1.140	0.984	98.42%	0.00	0.010
802.11n HT40 CDD 2TX	1.124	1.140	0.986	98.60%	0.00	0.010
802.11n HT40 CDD 3TX	1.123	1.140	0.985	98.51%	0.00	0.010
802.11n HT40 STBC/SDM 2TX	1.128	1.146	0.984	98.43%	0.00	0.010
802.11n HT40 STBC/SDM 3TX	1.127	1.145	0.984	98.43%	0.00	0.010
802.11n HT40 BF 2TX	2.823	3.386	0.834	83.38%	0.79	0.354
802.11n HT40 BF 3TX	2.055	2.350	0.874	87.45%	0.58	0.487
802.11ac VHT80 1TX	0.942	0.962	0.979	97.92%	0.09	1.062
802.11ac VHT80 CDD 2TX	0.460	0.479	0.960	95.99%	0.18	2.175
802.11ac VHT80 CDD 3TX	0.460	0.479	0.960	96.03%	0.18	2.174
802.11ac VHT80 STBC/SDM 2TX	0.467	0.488	0.958	95.84%	0.18	2.140
802.11ac VHT80 STBC/SDM 3TX	0.467	0.487	0.959	95.89%	0.18	2.141
802.11ac VHT80 BF 2TX	2.620	3.090	0.848	84.79%	0.72	0.382
802.11ac VHT80 BF 3TX	2.275	2.625	0.867	86.67%	0.62	0.440

DUTY CYCLE PLOTS

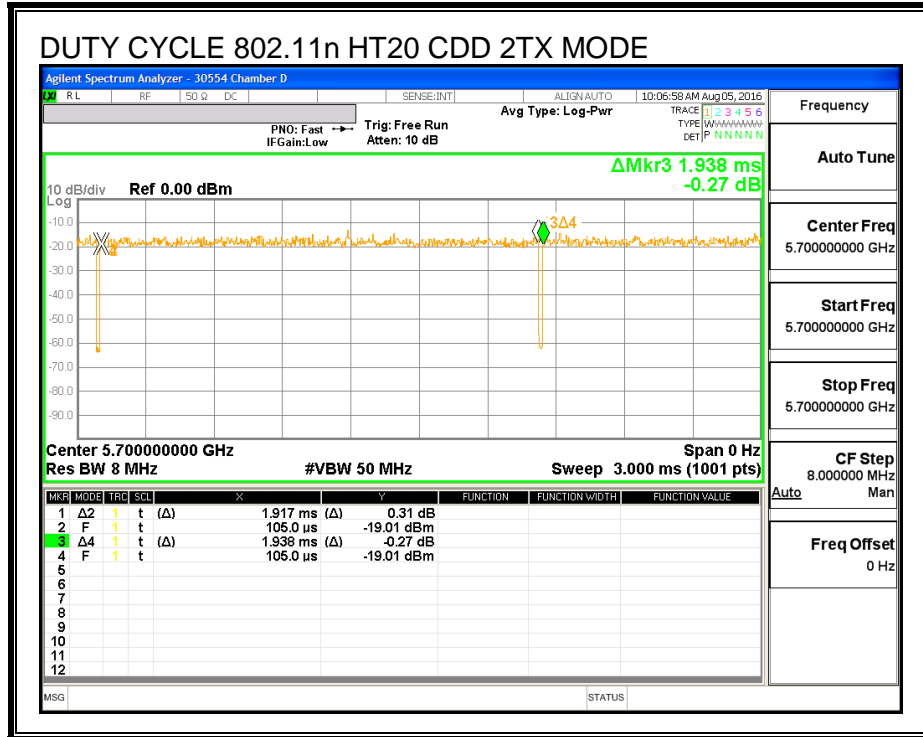
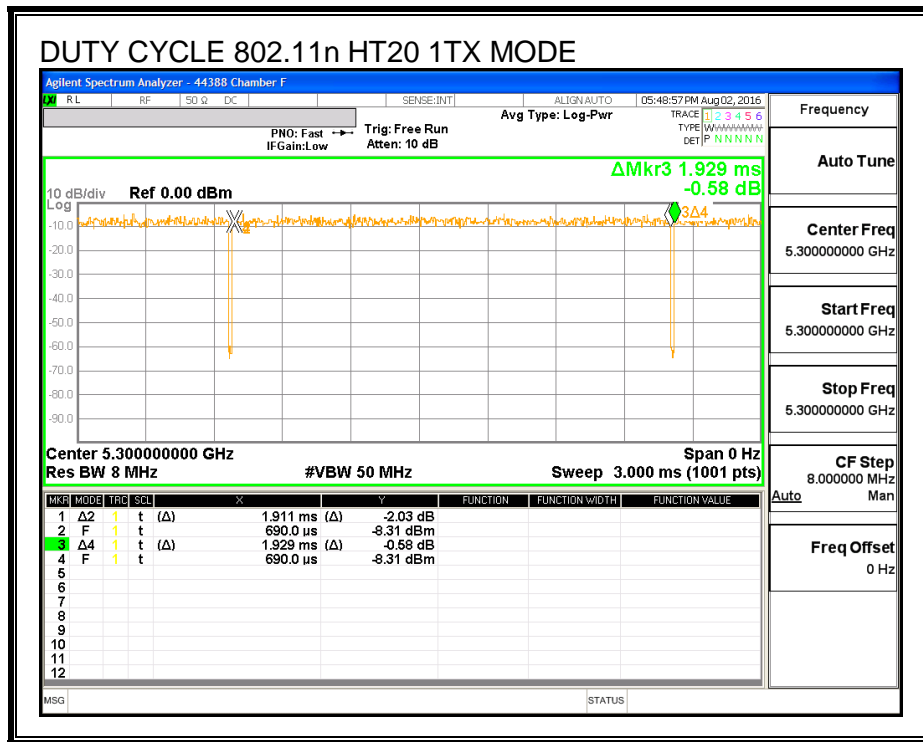

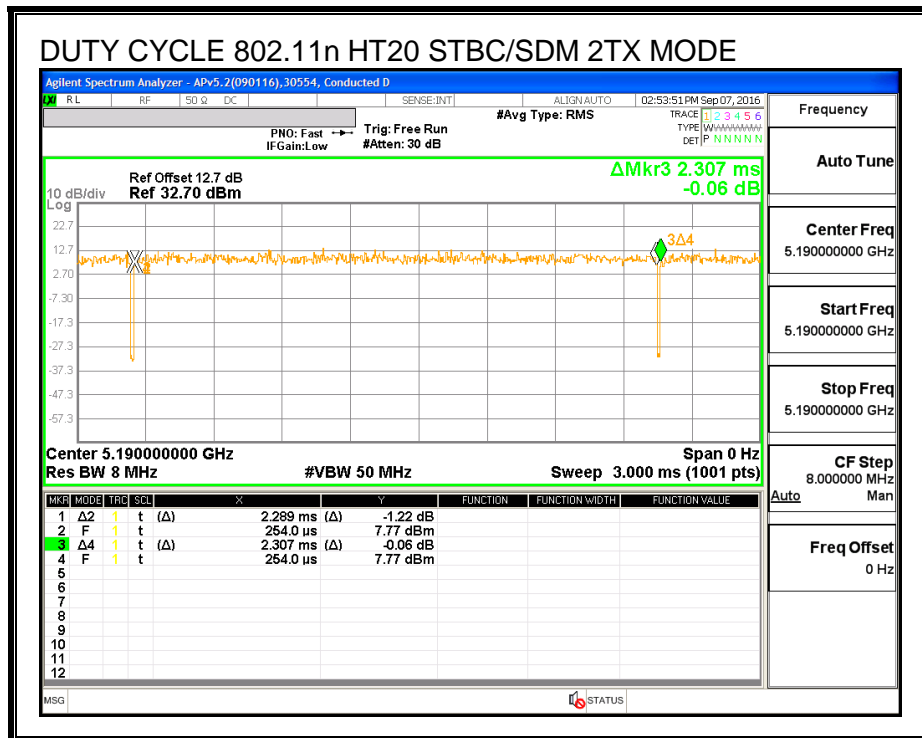
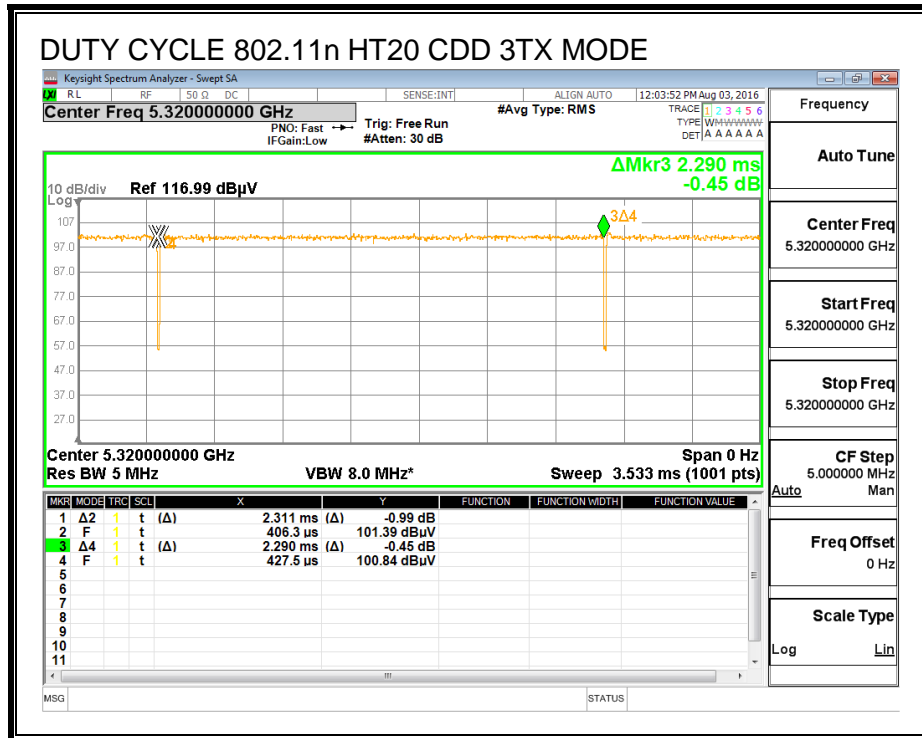

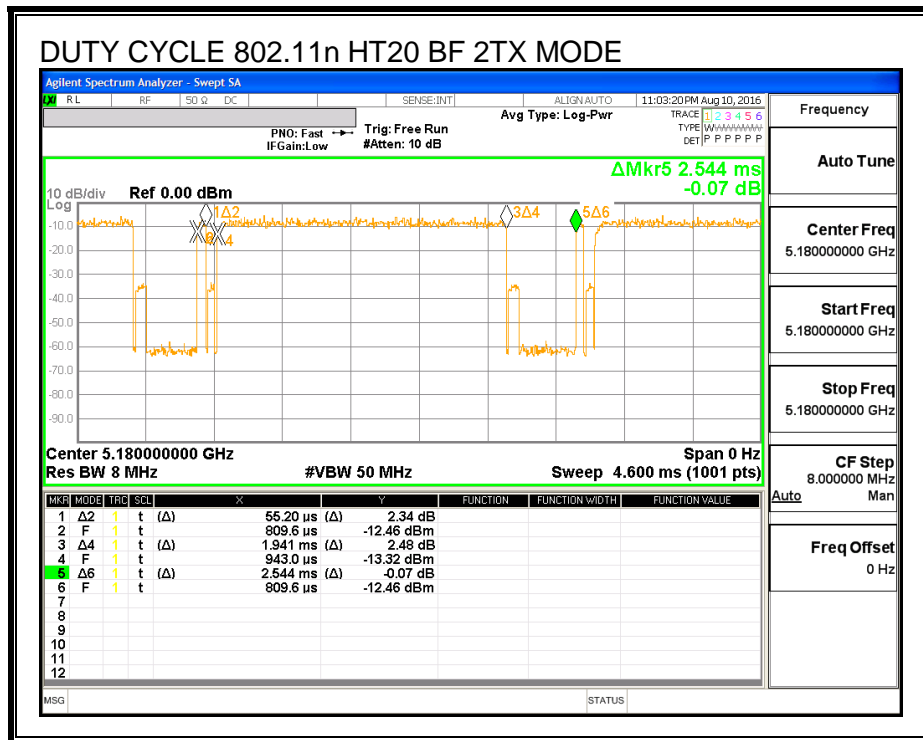
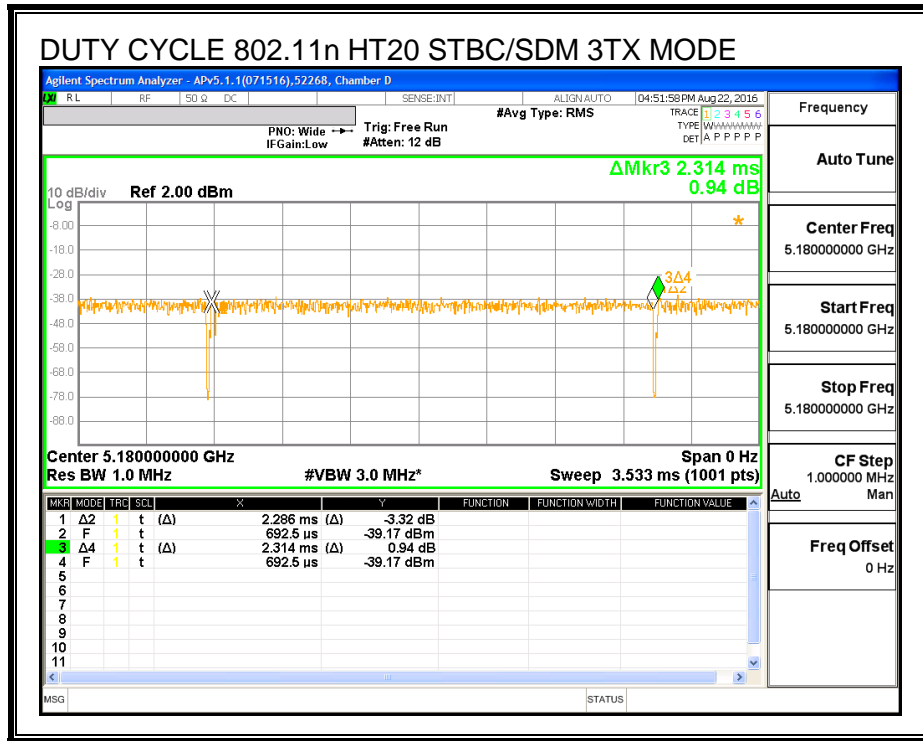

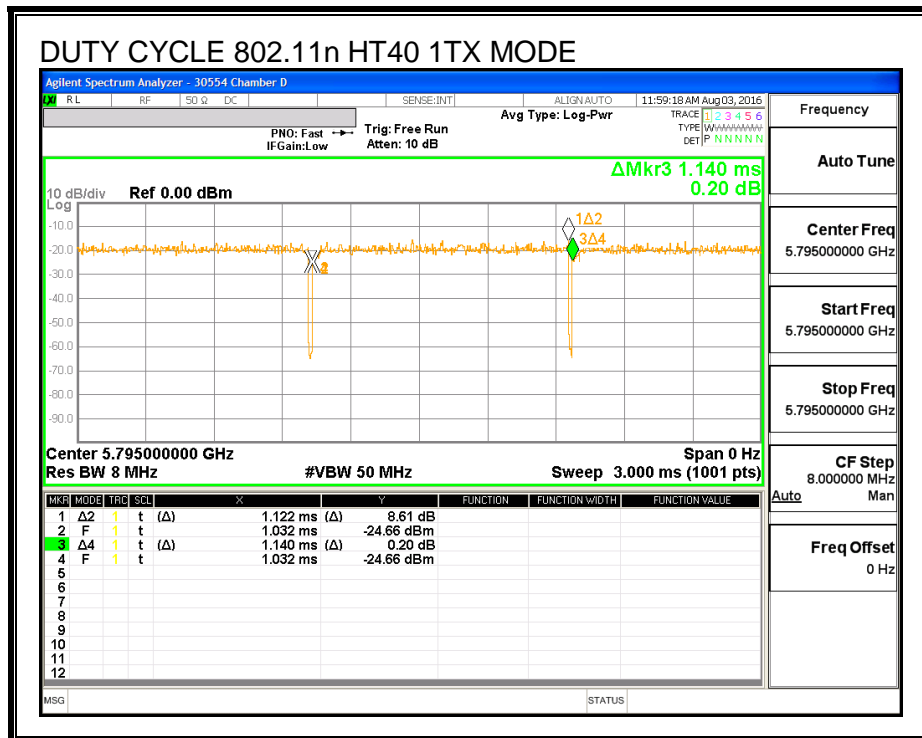
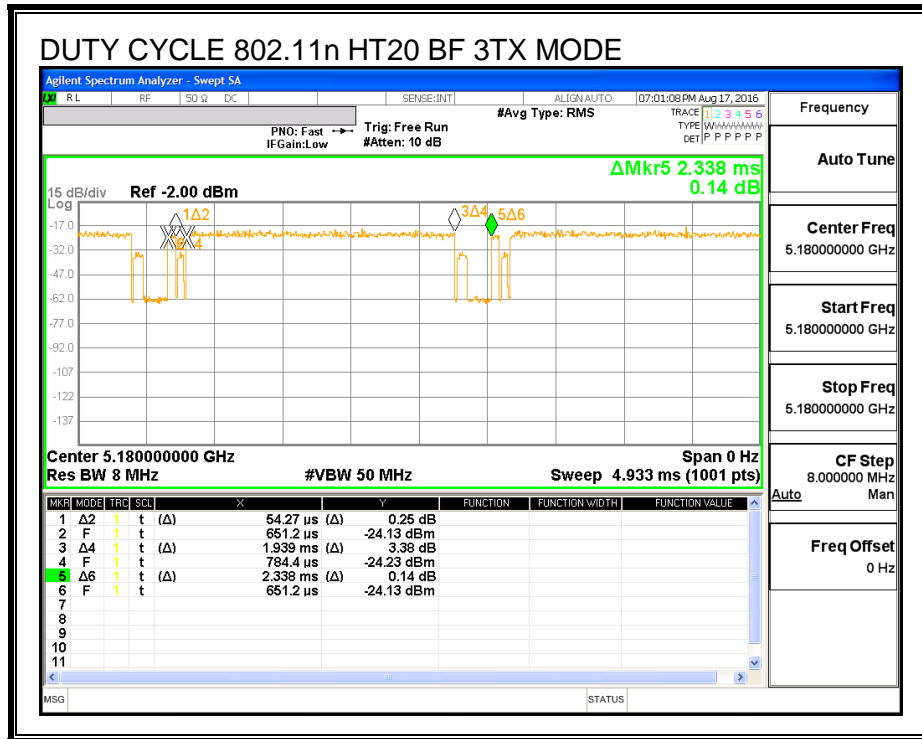

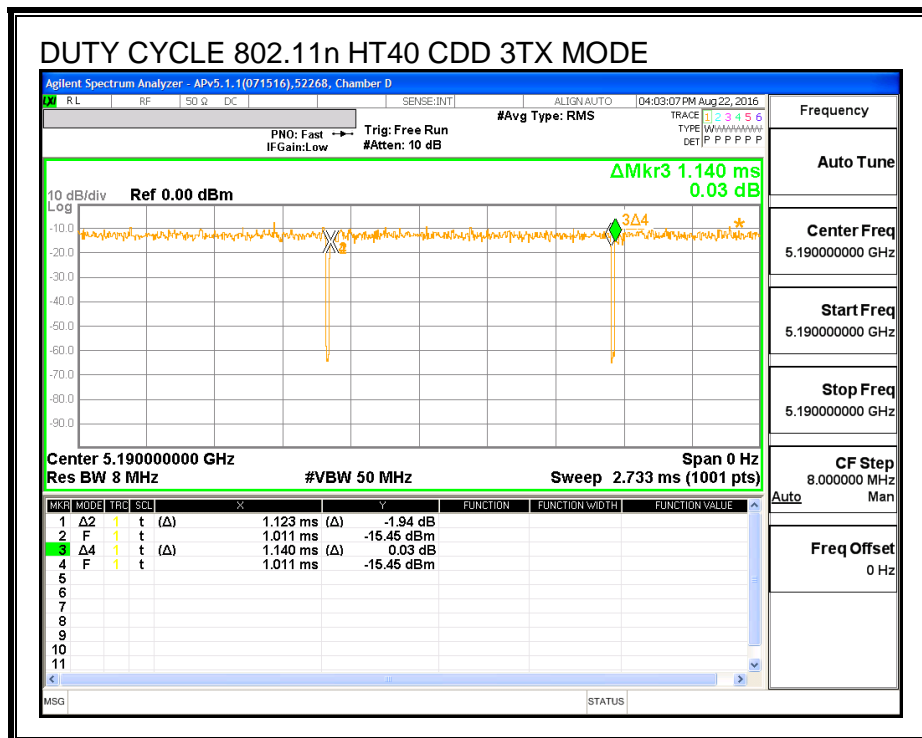
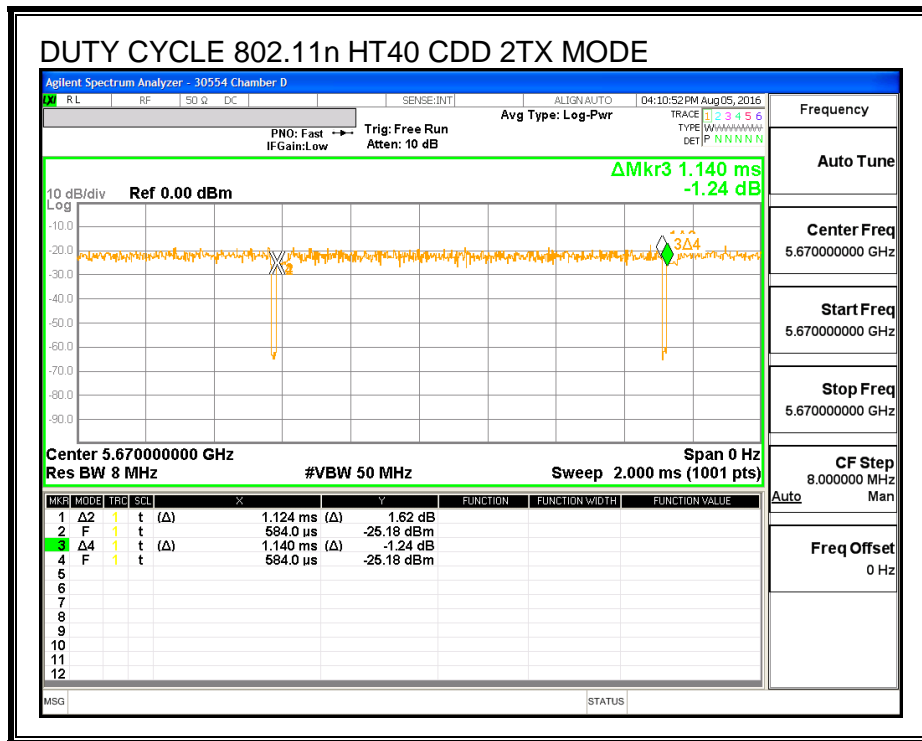

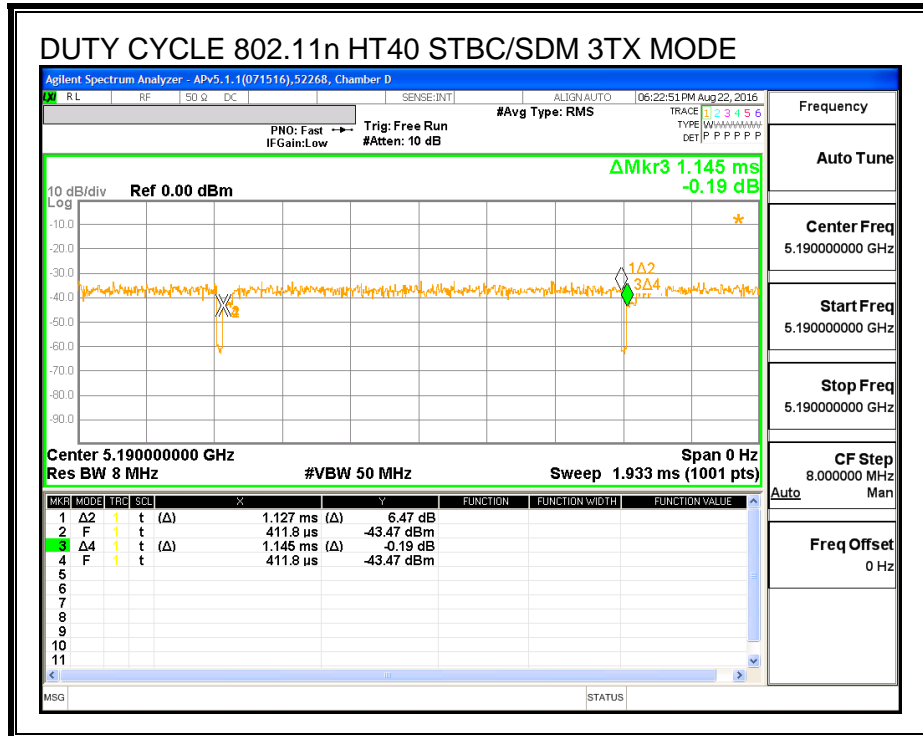
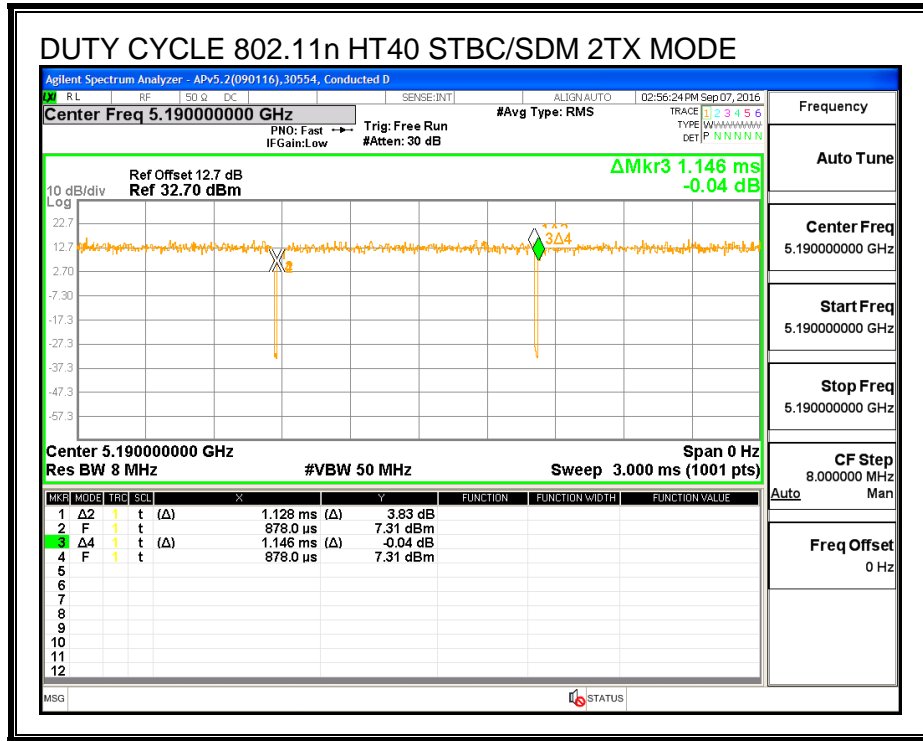

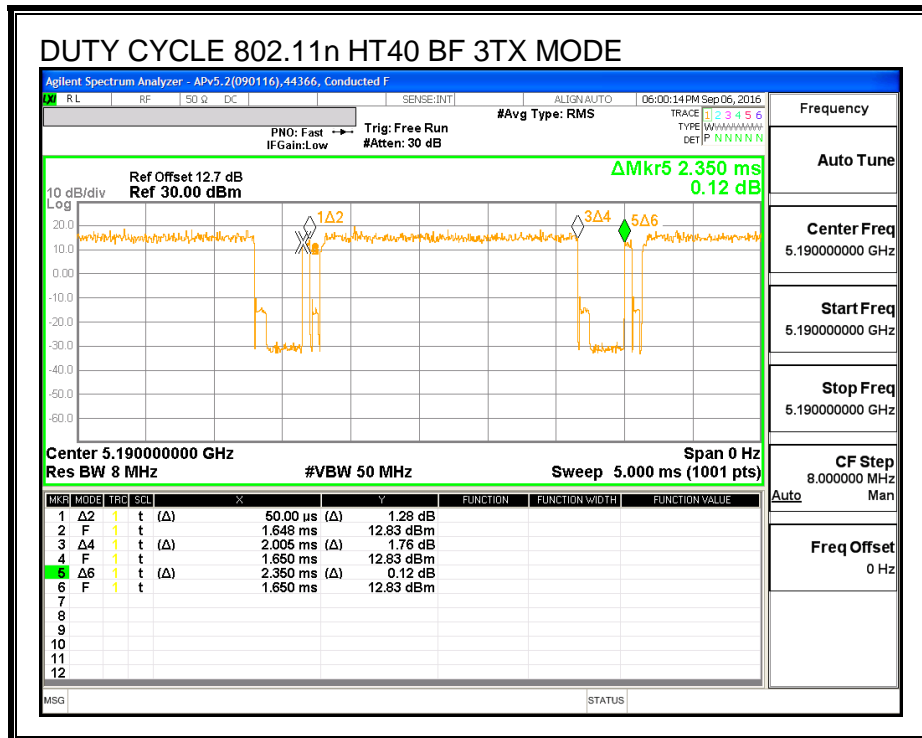
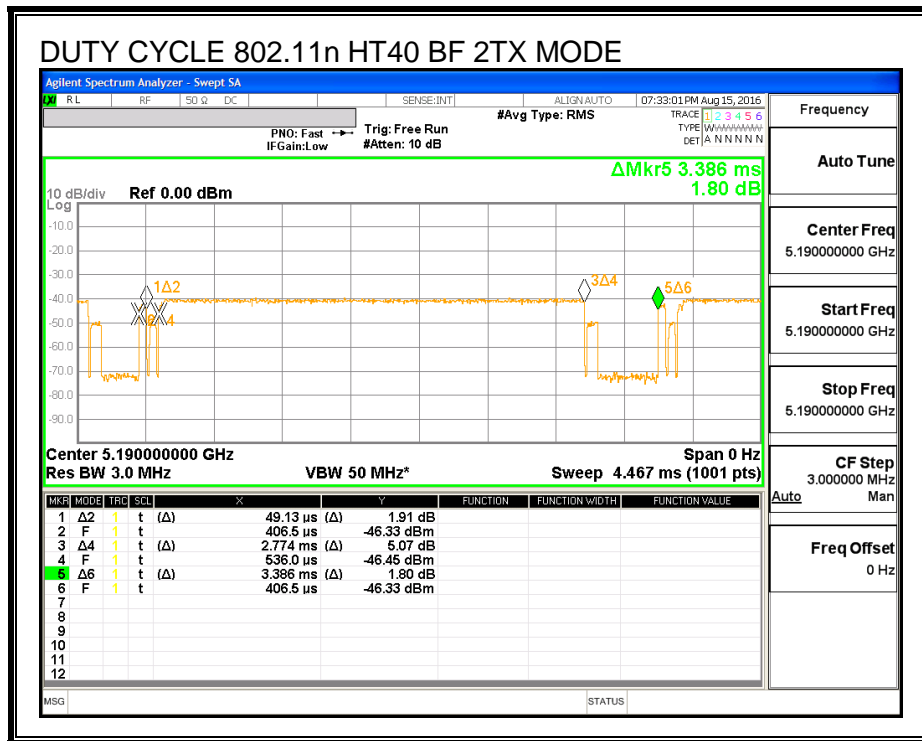

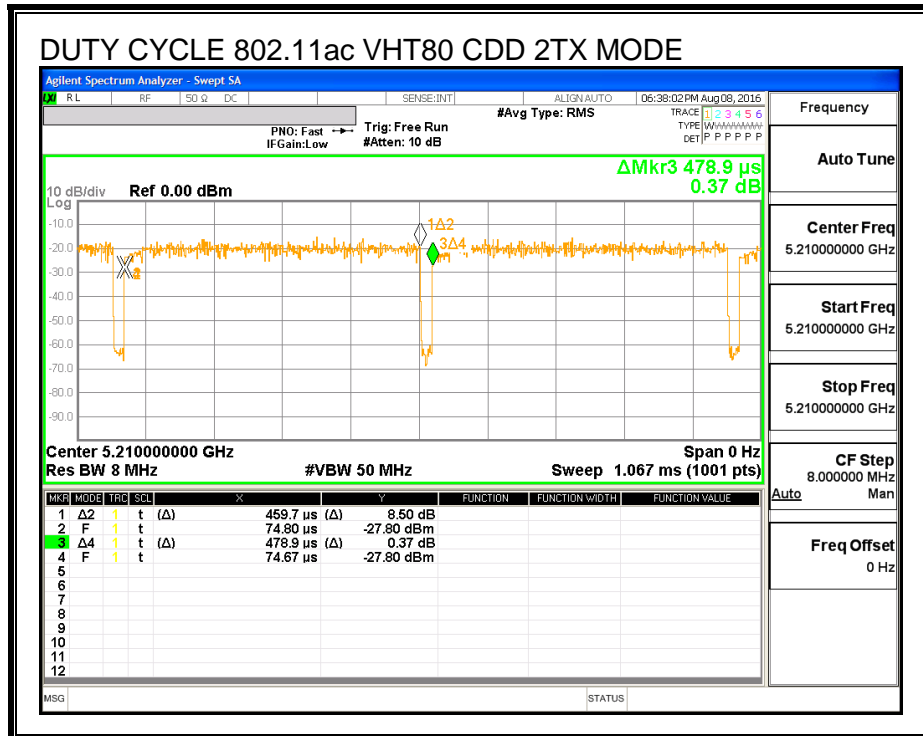
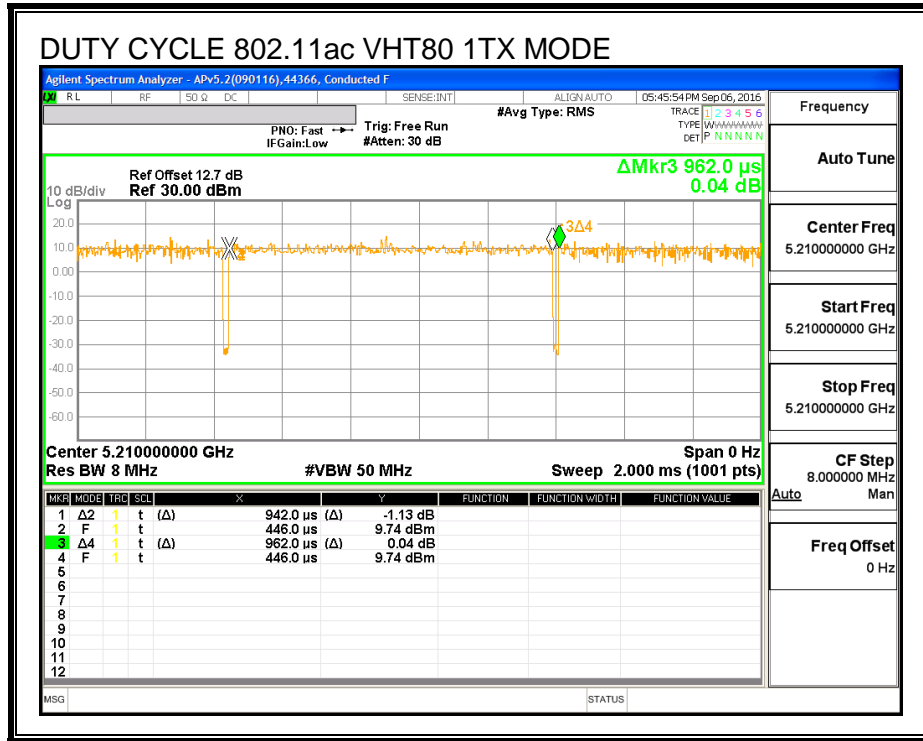

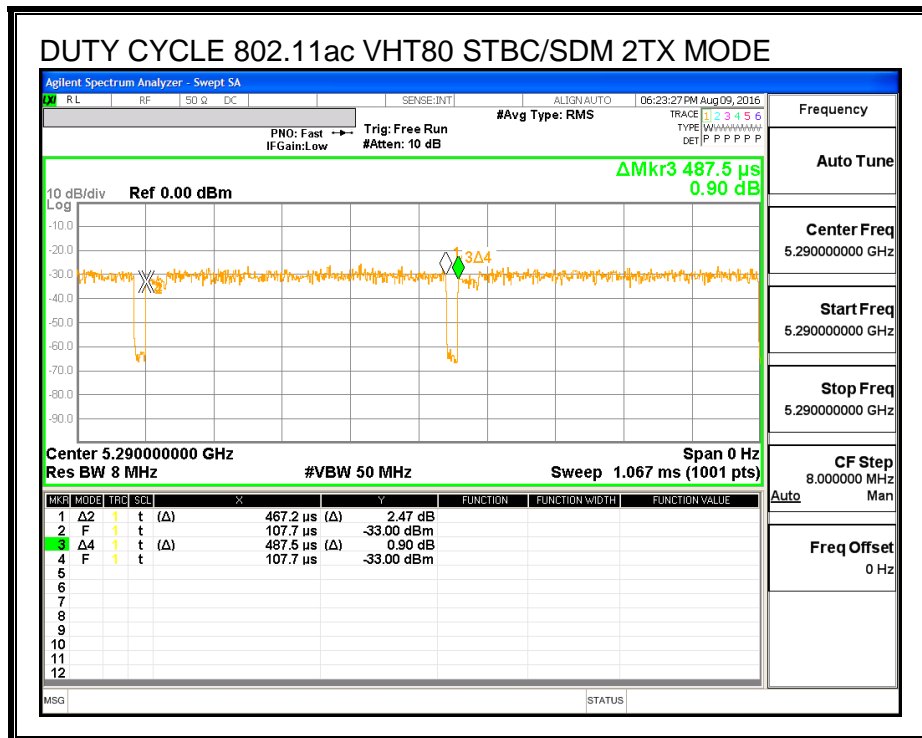
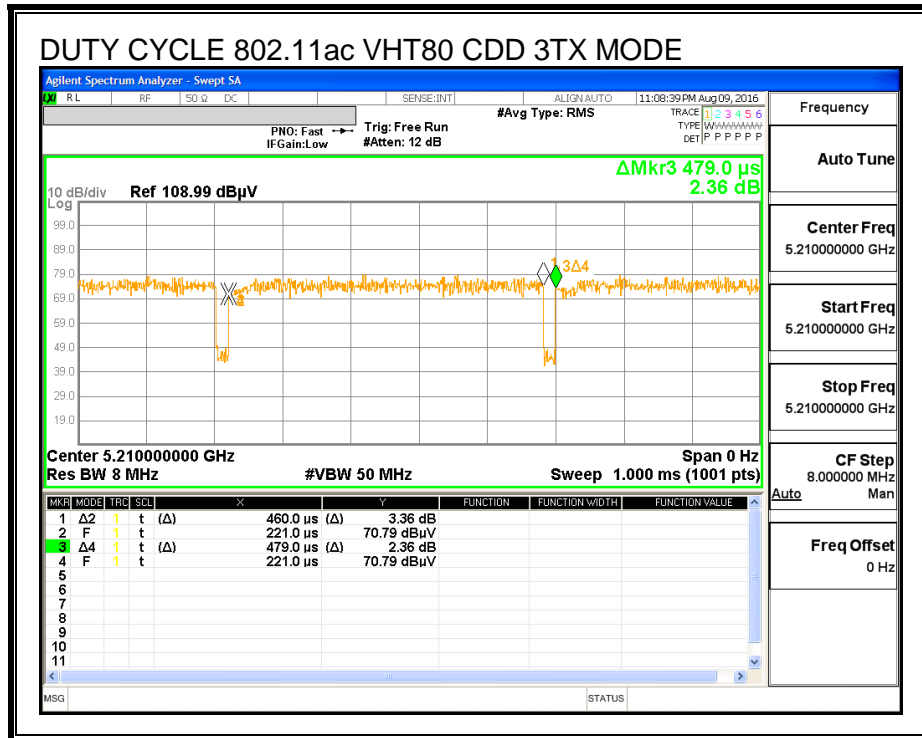

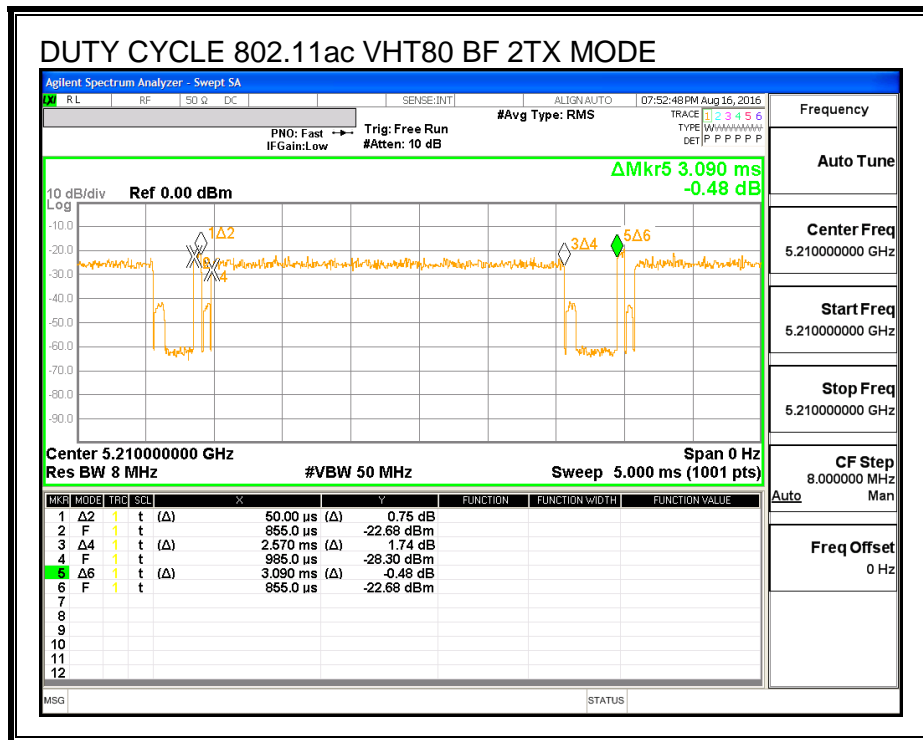
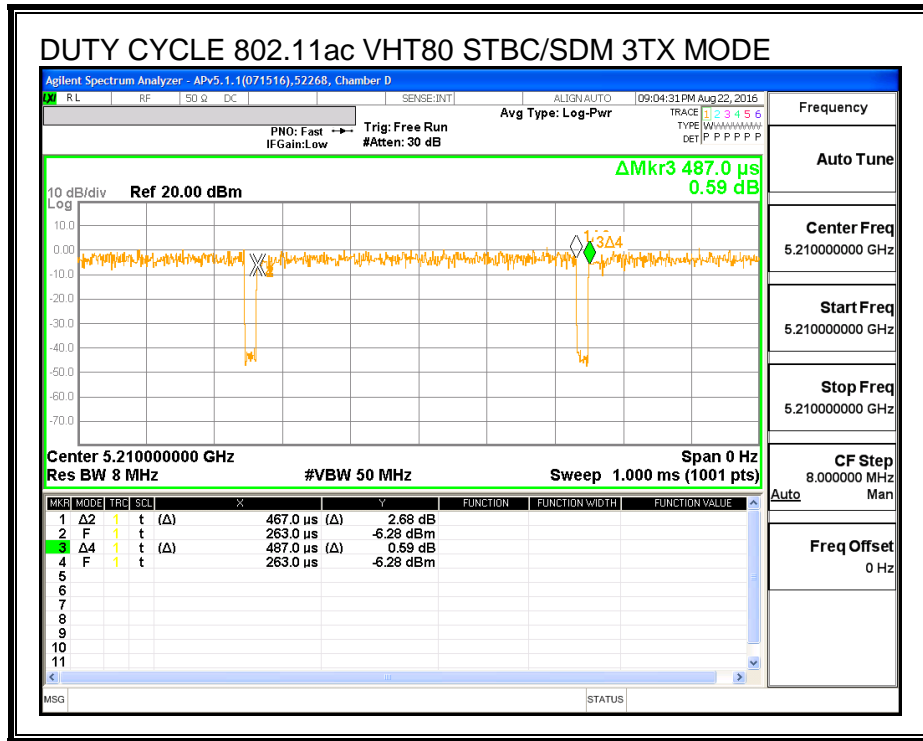

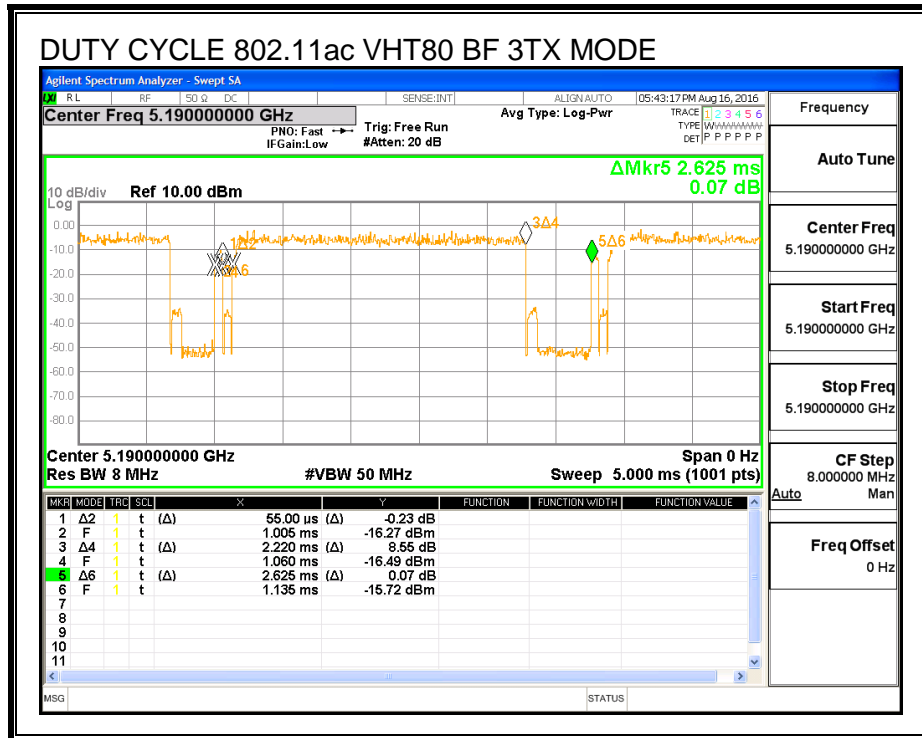

7.2. MEASUREMENT METHODS

6 dB Emission BW: KDB 789033 D02 v01r03, Section C.

26 dB Emission BW: KDB 789033 D02 v01r03, Section C.

99% Occupied BW: KDB 789033 D02 v01r03, Section D.

Conducted Output Power: KDB 789033 D02 v01r03, Section E.3.b (Method PM-G).

Power Spectral Density: KDB 789033 D02 v01r03, Section F (Method SA-2).

Unwanted emissions in restricted bands: KDB 789033 D02 v01r03, Sections G.3, G.4, G.5, and G.6.

Unwanted emissions in non-restricted bands: KDB 789033 D02 v01r03, Sections G.3, G.4, and G.5.

8. ANTENNA PORT TEST RESULTS

8.1. 802.11n HT20 CHAIN 0 MODE IN THE 5.8 GHz BAND

8.1.1. 6 dB BANDWIDTH

LIMITS

FCC §15.407 (e)

The minimum 6 dB bandwidth shall be at least 500 kHz.

RESULTS

Channel	Frequency (MHz)	6 dB Bandwidth (MHz)	Minimum Limit (MHz)
Low	5745	17.631	0.5
Mid	5785	17.631	0.5
High	5825	17.658	0.5

6 dB BANDWIDTH

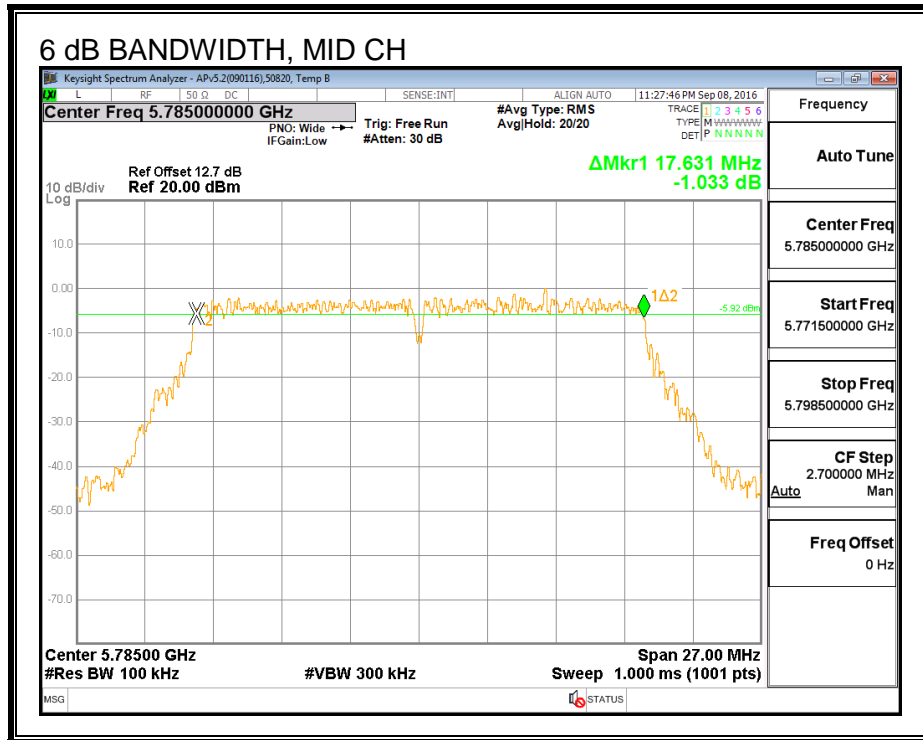
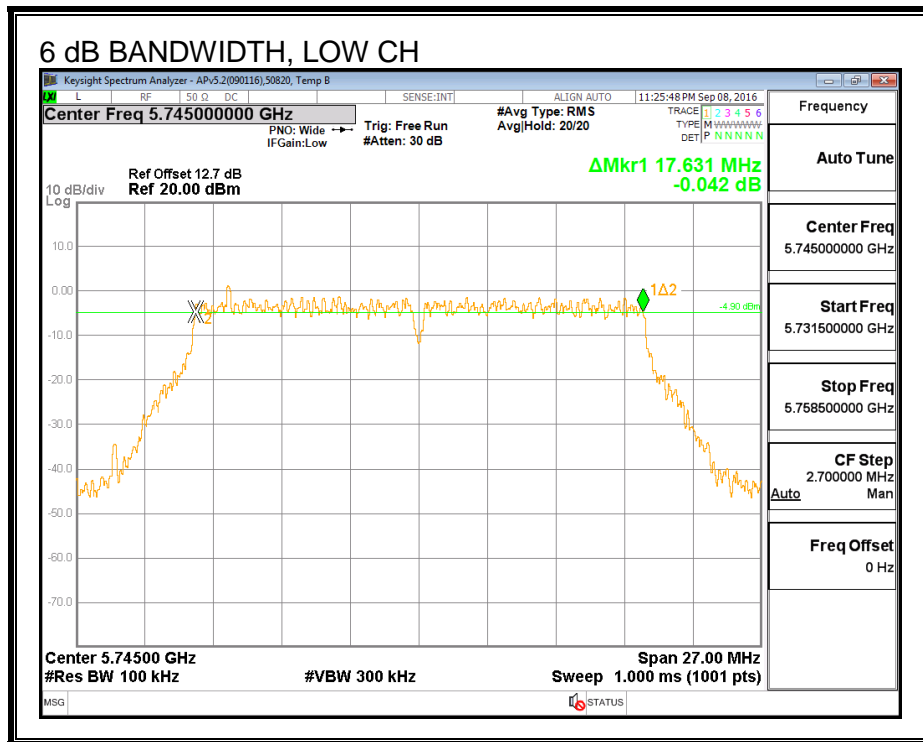

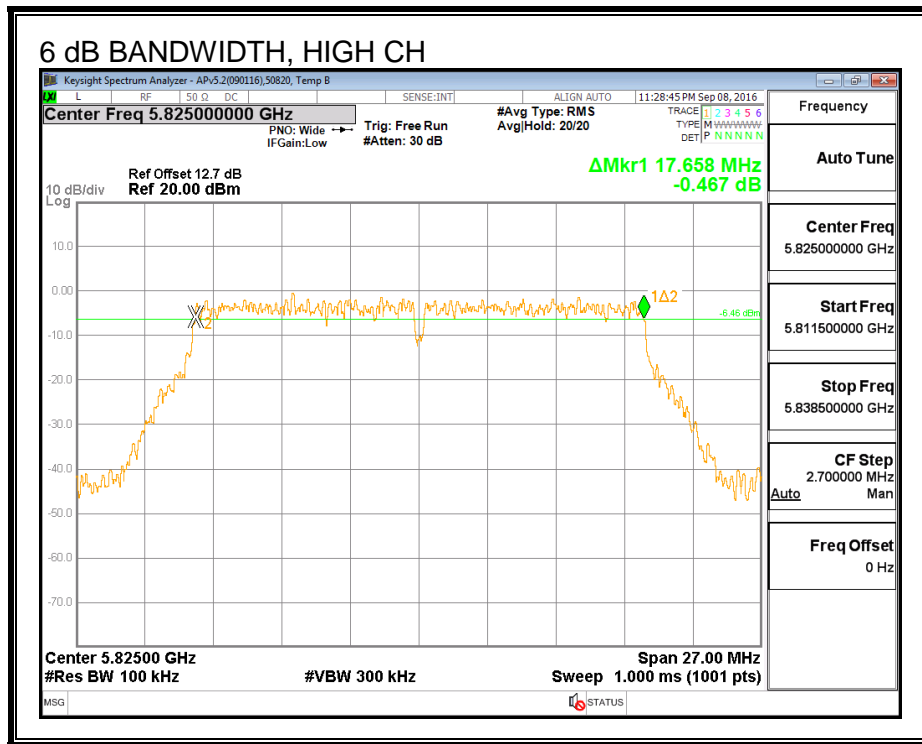

8.1.2. 26 dB BANDWIDTH

LIMITS

None, for reporting purposes only

RESULTS

Channel	Frequency (MHz)	26 dB Bandwidth (MHz)
Low	5745	21.879
Mid	5785	21.945
High	5825	21.879

26 dB BANDWIDTH

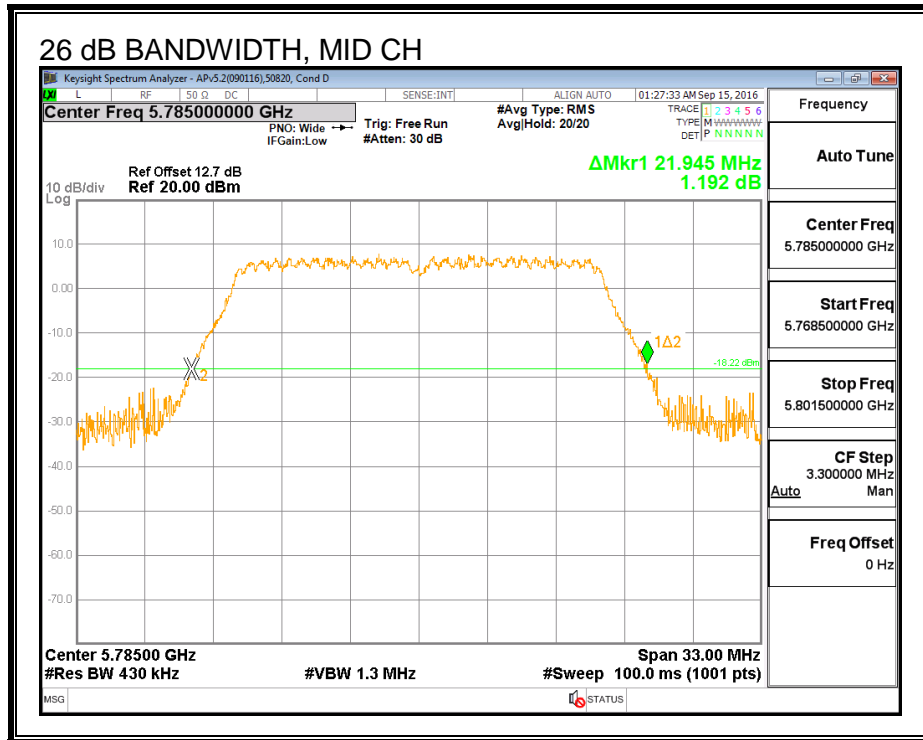
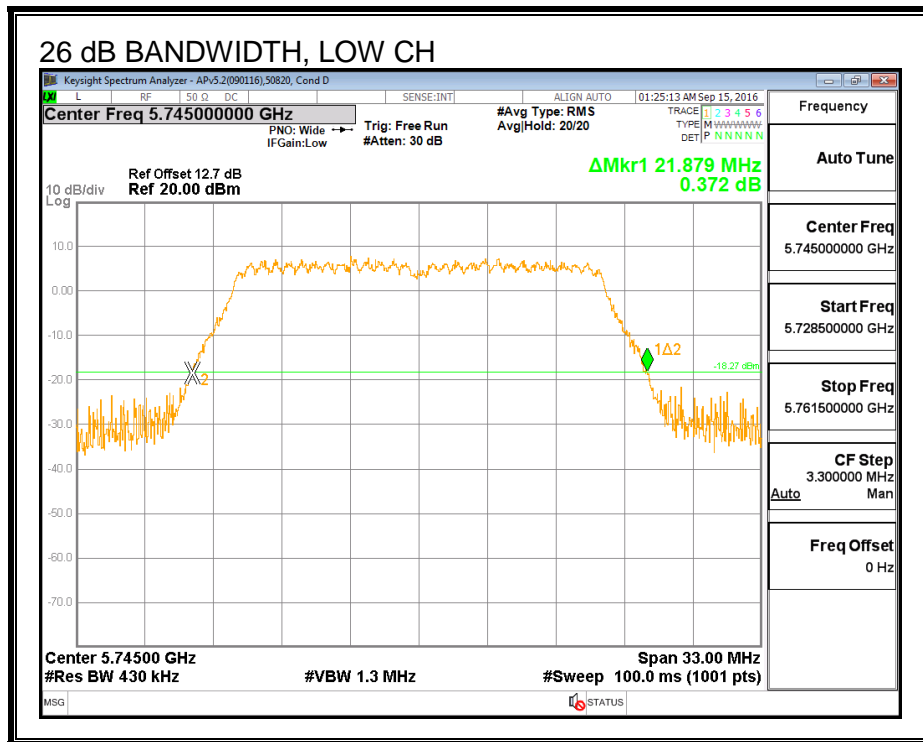

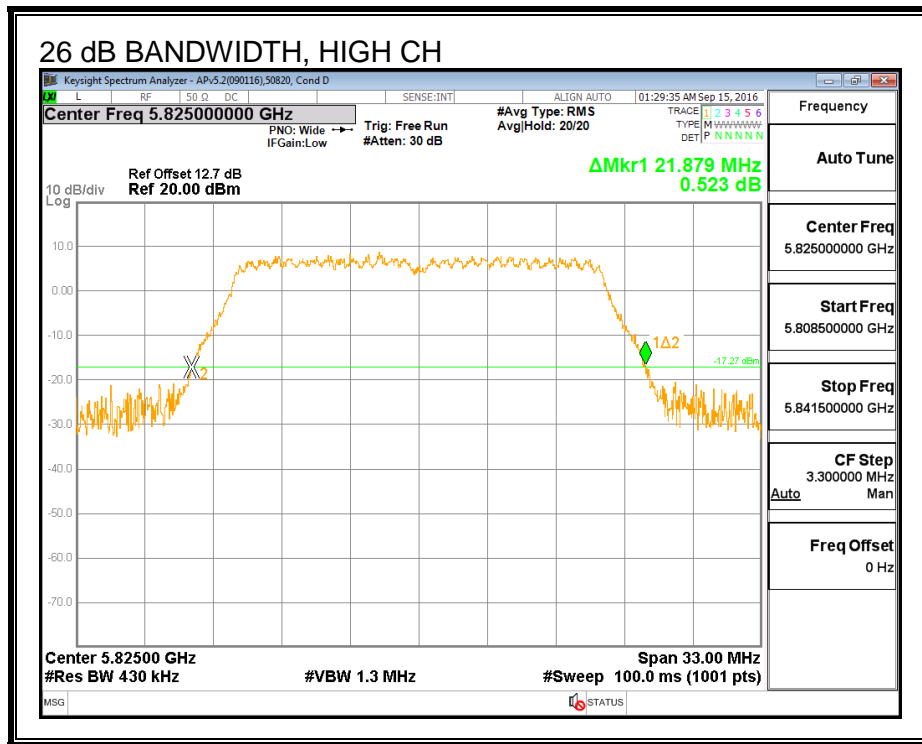

8.1.3. 99% BANDWIDTH

LIMITS

None; for reporting purposes only.

RESULTS

Frequency (MHz)	99% Bandwidth (MHz)
5745	17.760
5785	17.758
5825	17.777

99% BANDWIDTH

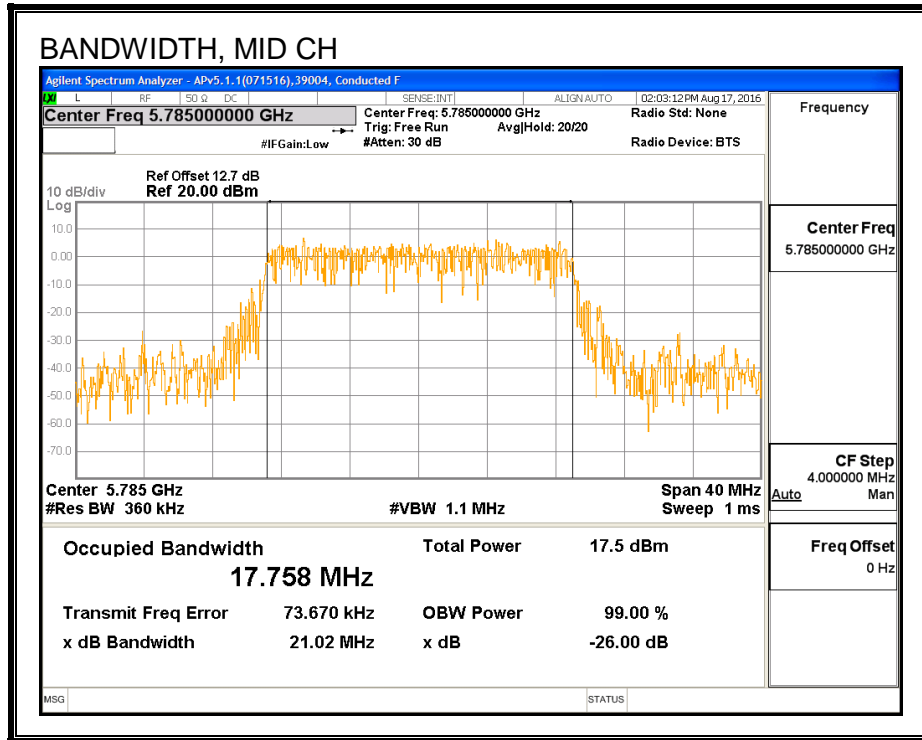
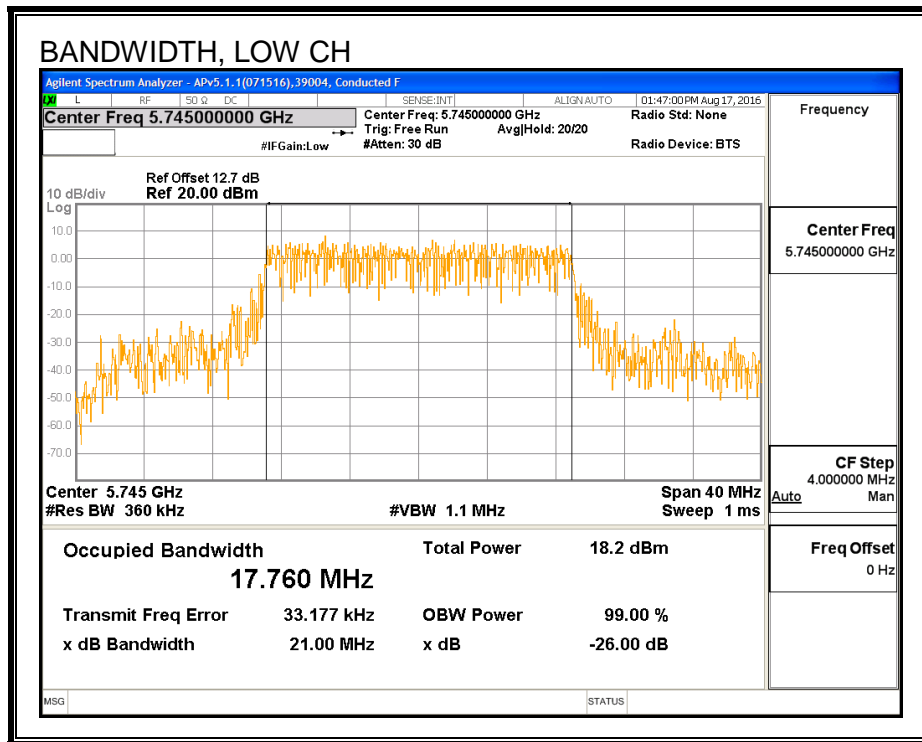

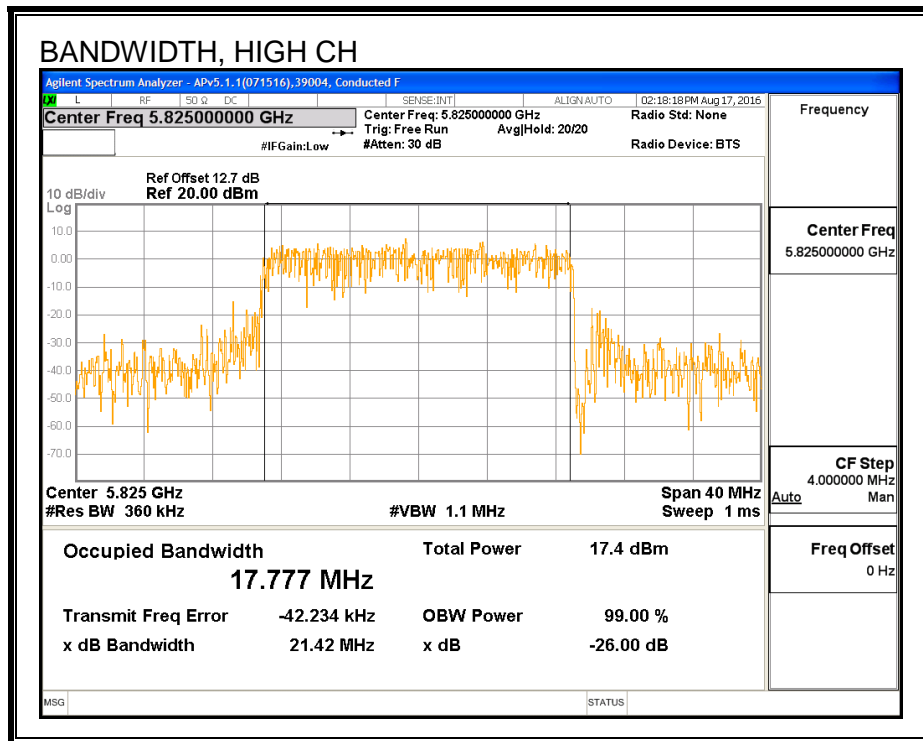

8.1.4. AVERAGE POWER (FCC/IC)

LIMITS

None; for reporting purposes only.

TEST PROCEDURE

Measurements perform using a wideband gated RF power meter.

RESULTS

ID:	30554	Date:	9/12/16
------------	-------	--------------	---------

Channel	Frequency (MHz)	Power (dBm)
Low	5745	12.73
Mid	5785	12.62
High	5825	12.66

8.1.5. OUTPUT POWER (FCC/IC)

LIMITS

FCC §15.407 (a) (3)

For the band 5.725-5.85 GHz, the maximum conducted output power over the frequency band of operation shall not exceed 1 W. In addition, the maximum power spectral density shall not exceed 30 dBm in any 500-kHz band. If transmitting antennas of directional gain greater than 6 dBi are used, both the maximum conducted output power and the maximum power spectral density shall be reduced by the amount in dB that the directional gain of the antenna exceeds 6 dBi.

IC RSS-247 (6.2.4) (1)

For the band 5.725-5.85 GHz, the maximum conducted output power over the frequency band of operation shall not exceed 1 W. In addition, the maximum power spectral density shall not exceed 30 dBm in any 500-kHz band. If transmitting antennas of directional gain greater than 6 dBi are used, both the maximum conducted output power and the maximum power spectral density shall be reduced by the amount in dB that the directional gain of the antenna exceeds 6 dBi.

TEST PROCEDURE

Measurements perform using a wideband gated RF power meter provided that the gate parameters are adjusted such that the power is measured only when the EUT is transmitting at its maximum power control level. Since the measurement is made only during the ON time of the transmitter, no duty cycle correction factor is required.

DIRECTIONAL ANTENNA GAIN

There is only one transmitter output therefore the directional gain is equal to the antenna gain.

RESULTS

ID:	30554	Date:	9/12/16
------------	-------	--------------	---------

Antenna Gain and Limit

Channel	Frequency (MHz)	Directional Gain for Power (dBi)	Power Limit (dBm)
Low	5745	4.00	30.00
Mid	5785	4.00	30.00
High	5825	4.00	30.00

Output Power Results

Channel	Frequency (MHz)	Chain 0 Meas Power (dBm)	Total Corr'd Power (dBm)	Power Limit (dBm)	Power Margin (dB)
Low	5745	12.73	12.73	30.00	-17.27
Mid	5785	12.62	12.62	30.00	-17.38
High	5825	12.66	12.66	30.00	-17.34

8.1.6. PSD (FCC/IC)

LIMITS

FCC §15.407 (a) (3)

For the band 5.725-5.85 GHz, the maximum conducted output power over the frequency band of operation shall not exceed 1 W. In addition, the maximum power spectral density shall not exceed 30 dBm in any 500-kHz band. If transmitting antennas of directional gain greater than 6 dBi are used, both the maximum conducted output power and the maximum power spectral density shall be reduced by the amount in dB that the directional gain of the antenna exceeds 6 dBi.

IC RSS-247 (6.2.4) (1)

For the band 5.725-5.85 GHz, the maximum conducted output power over the frequency band of operation shall not exceed 1 W. In addition, the maximum power spectral density shall not exceed 30 dBm in any 500-kHz band. If transmitting antennas of directional gain greater than 6 dBi are used, both the maximum conducted output power and the maximum power spectral density shall be reduced by the amount in dB that the directional gain of the antenna exceeds 6 dBi.

DIRECTIONAL ANTENNA GAIN

There is only one transmitter output therefore the directional gain is equal to the antenna gain.

RESULTS

Antenna Gain and Limits

Channel	Frequency (MHz)	Directional Gain (dBi)	PSD Limit (dBm)
Low	5745	4.00	30.00
Mid	5785	4.00	30.00
High	5825	4.00	30.00

Duty Cycle CF (dB)	0.00	Included in Calculations of Corr'd PSD
---------------------------	------	---

PSD Results

Channel	Frequency (MHz)	Chain 0 Meas PSD (dBm)	Total Corr'd PSD (dBm)	PSD Limit (dBm)	PSD Margin (dB)
Low	5745	-1.36	-1.36	30.00	-31.36
Mid	5785	-1.30	-1.30	30.00	-31.30
High	5825	-1.36	-1.36	30.00	-31.36

PSD

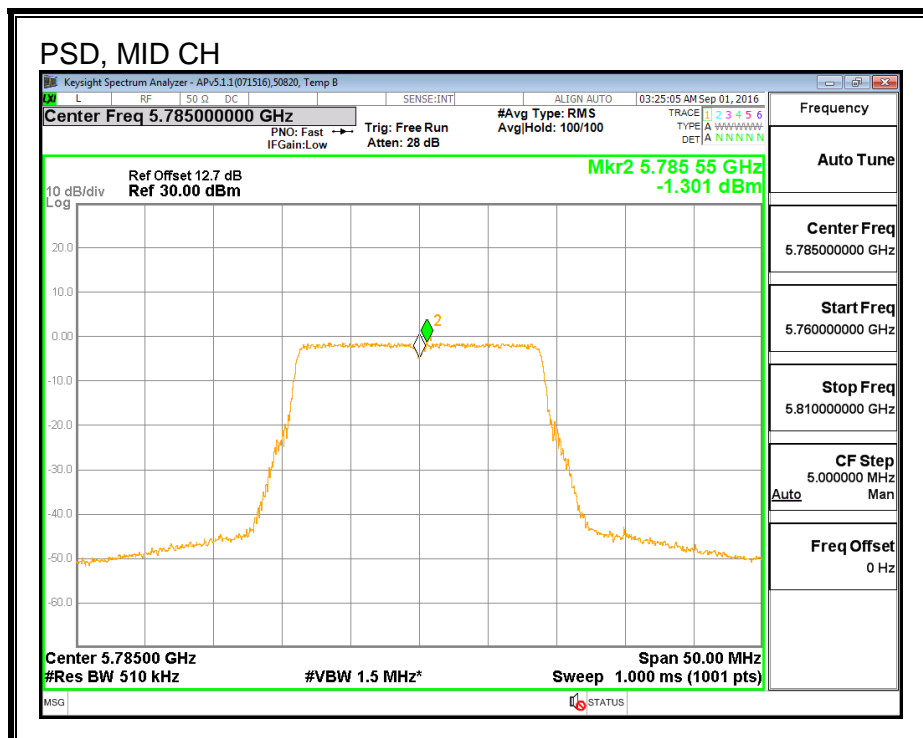
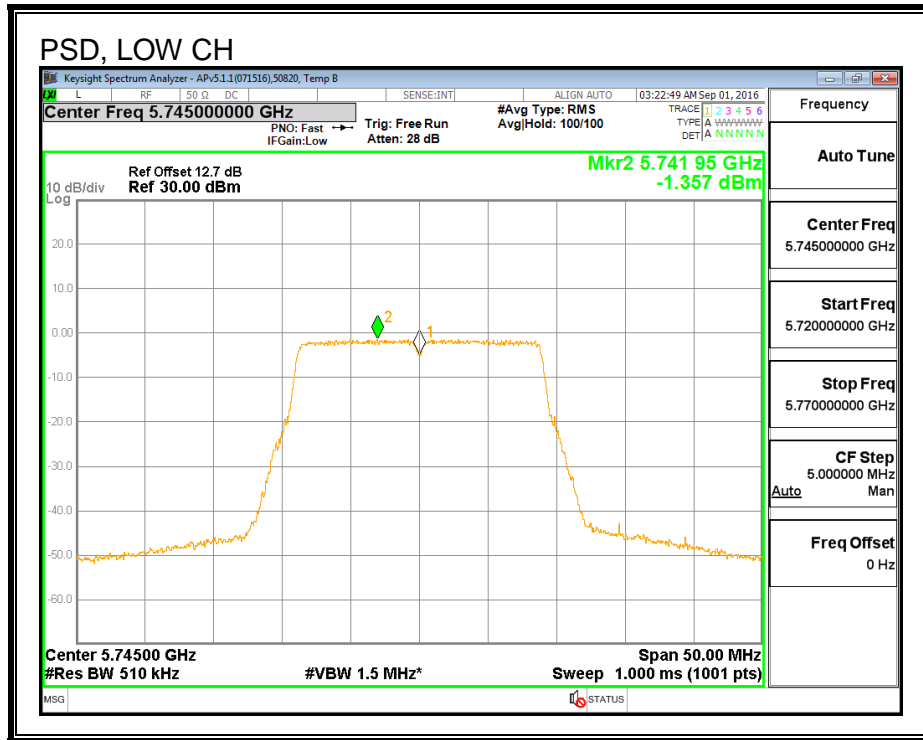

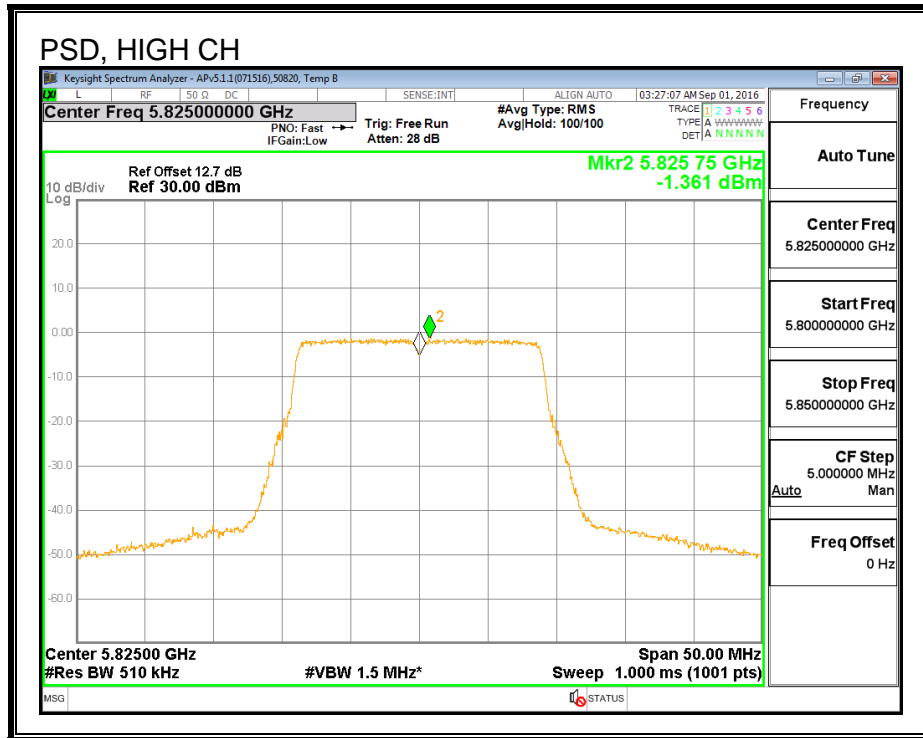

8.2. 802.11n HT20 CHAIN 1 MODE IN THE 5.8 GHz BAND

8.2.1. 6 dB BANDWIDTH

LIMITS

FCC §15.407 (e)

The minimum 6 dB bandwidth shall be at least 500 kHz.

RESULTS

Channel	Frequency (MHz)	6 dB Bandwidth (MHz)	Minimum Limit (MHz)
Low	5745	17.766	0.5
Mid	5785	17.604	0.5
High	5825	17.577	0.5

6 dB BANDWIDTH

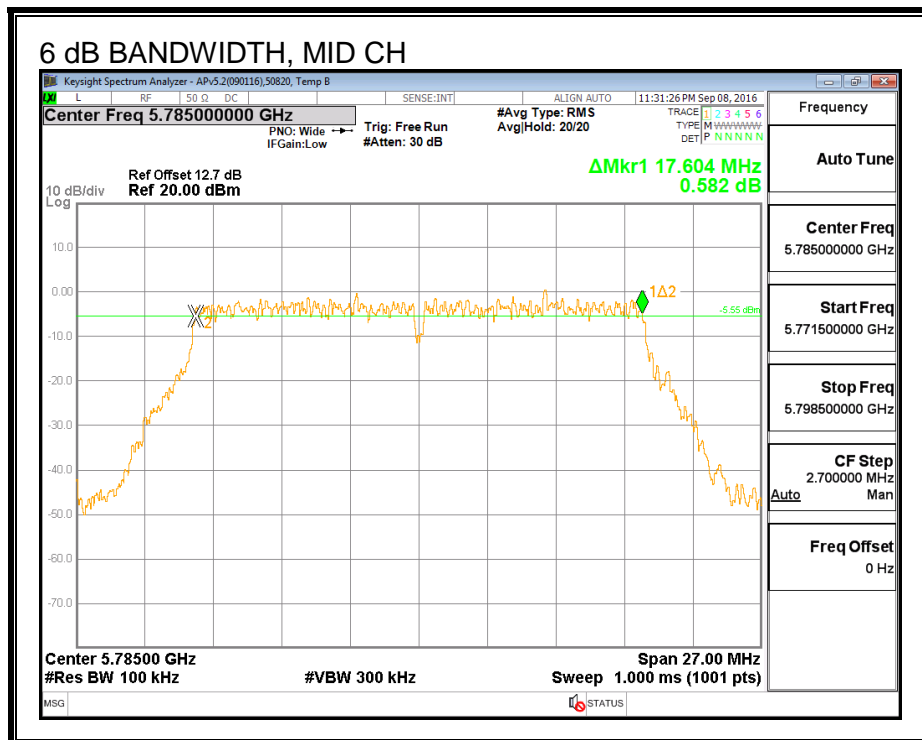
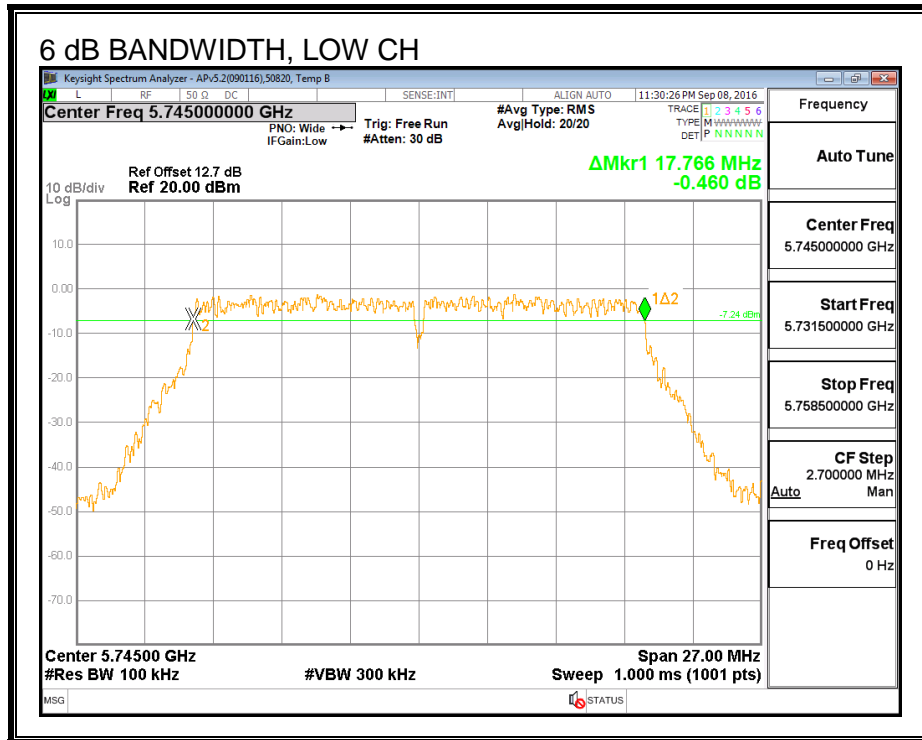

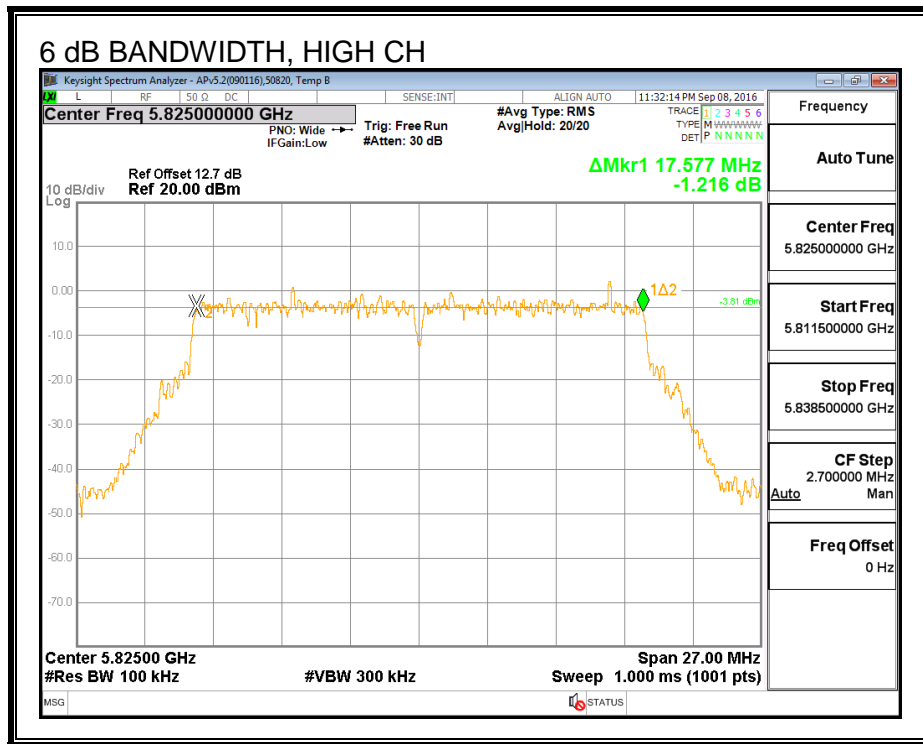

8.2.2. 26 dB BANDWIDTH

LIMITS

None, for reporting purposes only

RESULTS

Channel	Frequency (MHz)	26 dB Bandwidth (MHz)
Low	5745	21.912
Mid	5785	22.032
High	5825	22.066

26 dB BANDWIDTH

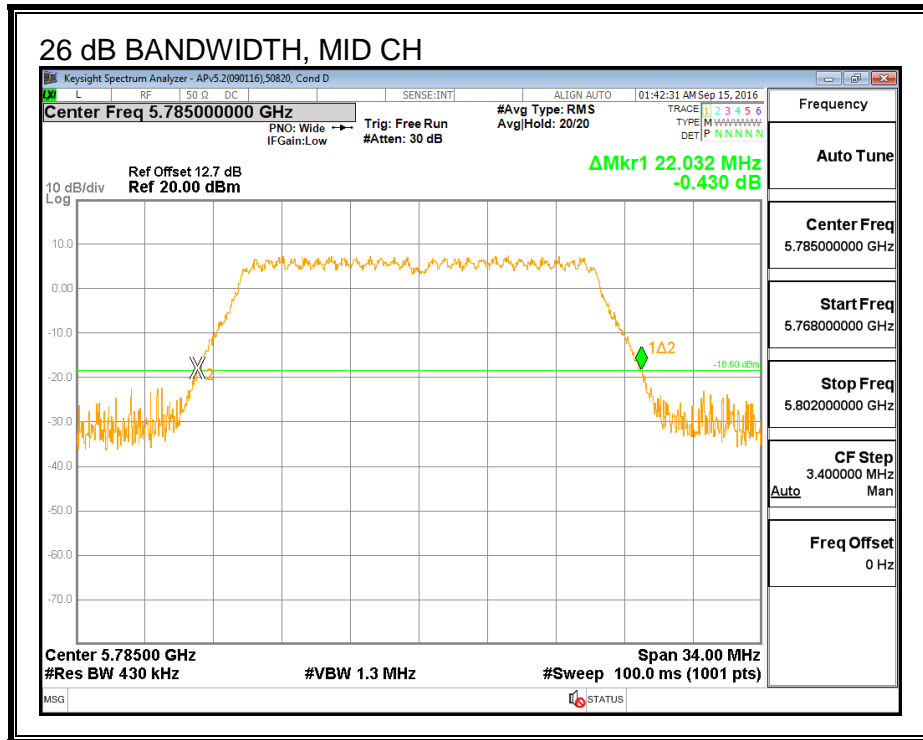
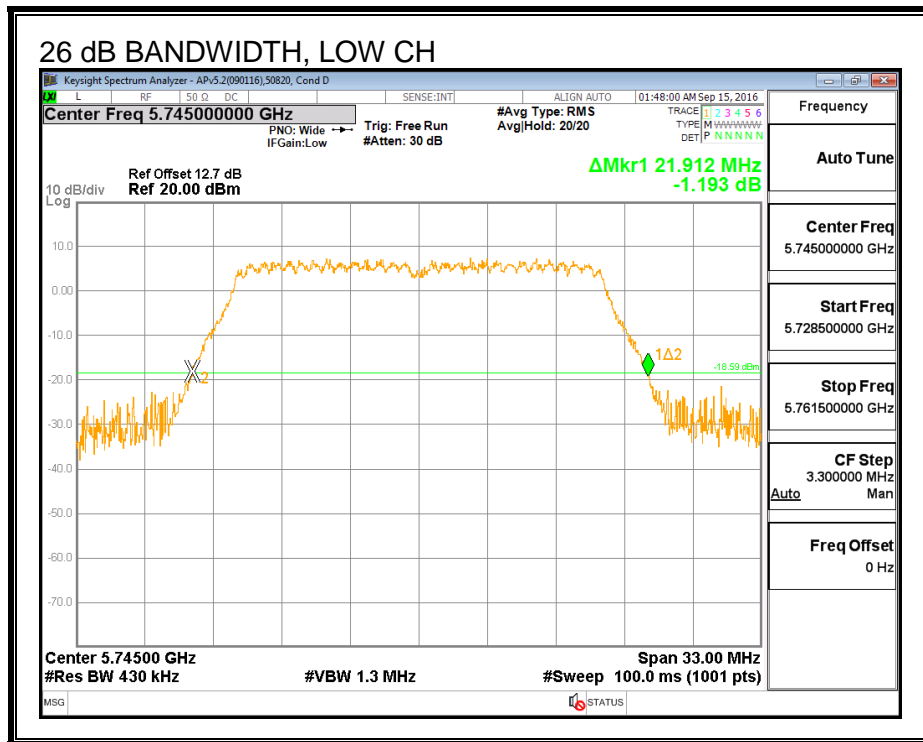

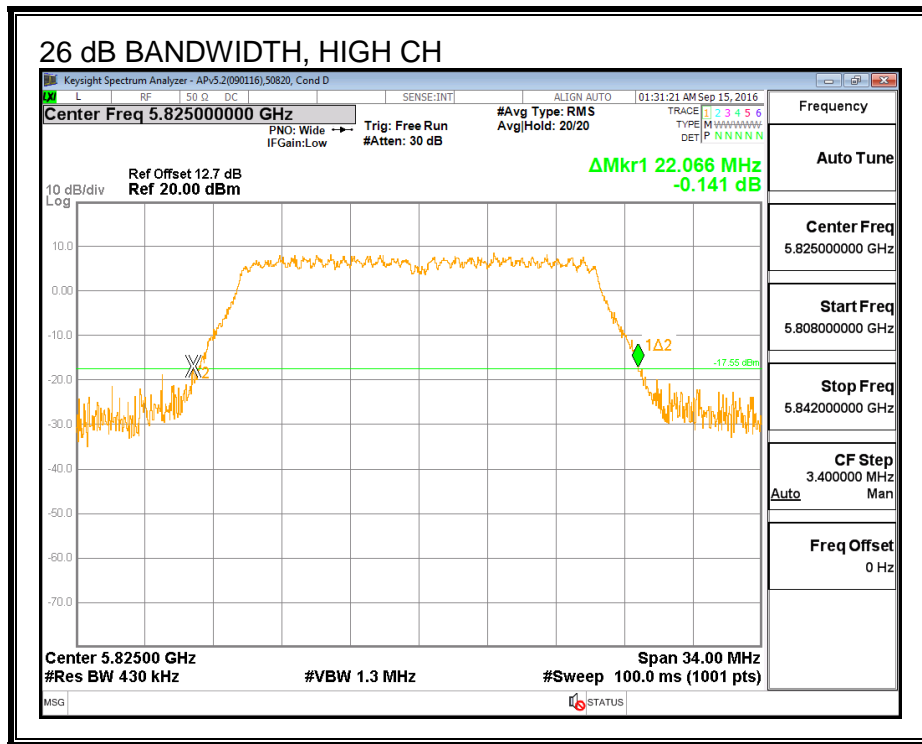

8.2.3. 99% BANDWIDTH

LIMITS

None; for reporting purposes only.

RESULTS

Channel	Frequency (MHz)	99% Bandwidth (MHz)
Low	5745	17.756
Mid	5785	17.795
High	5825	17.756

99% BANDWIDTH

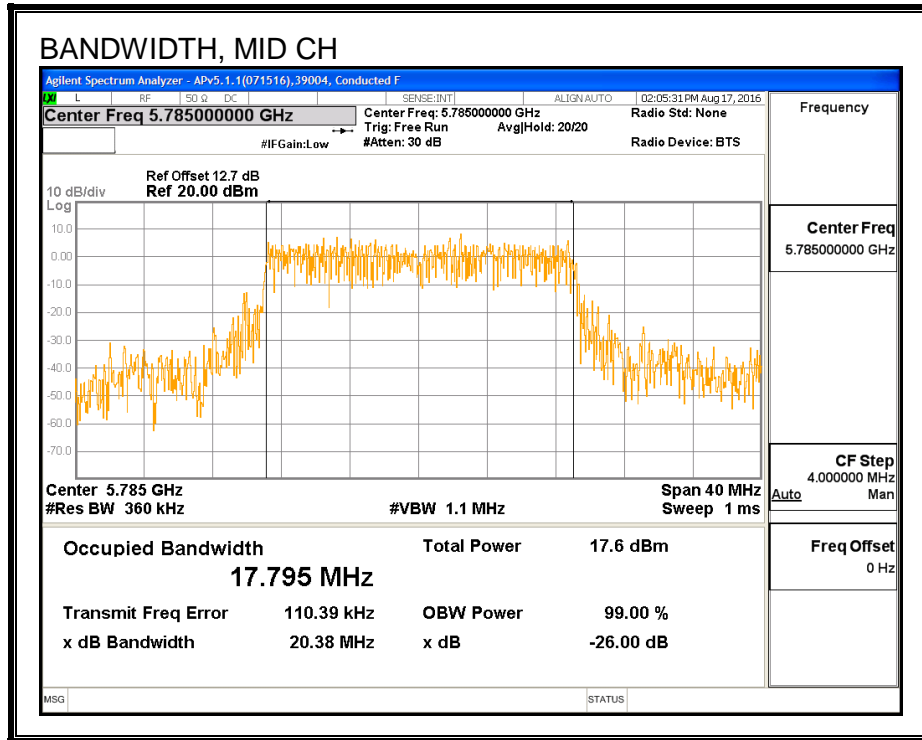
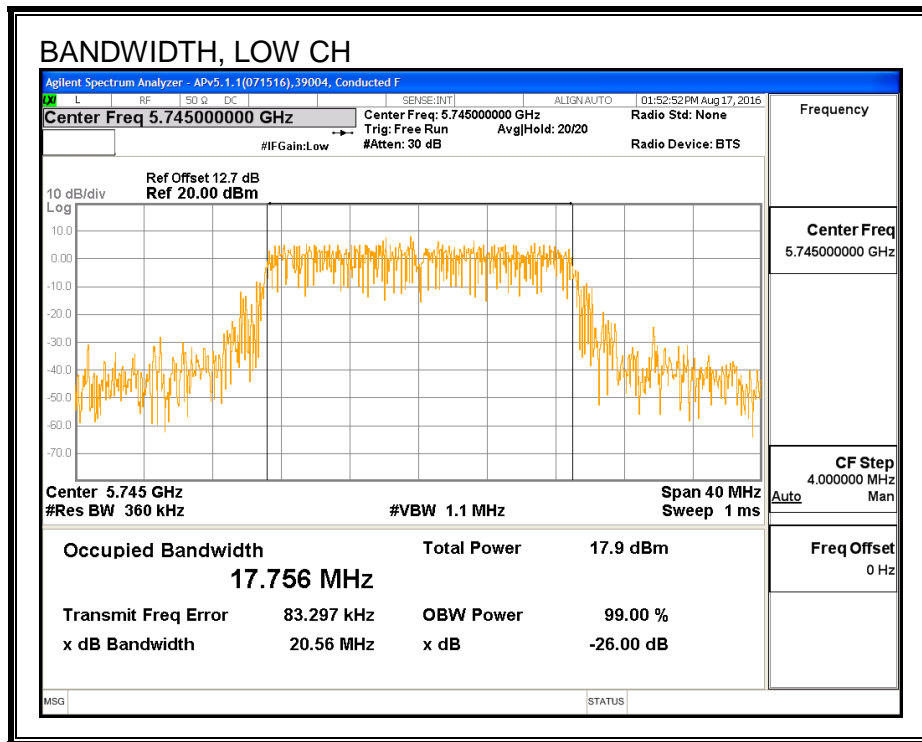

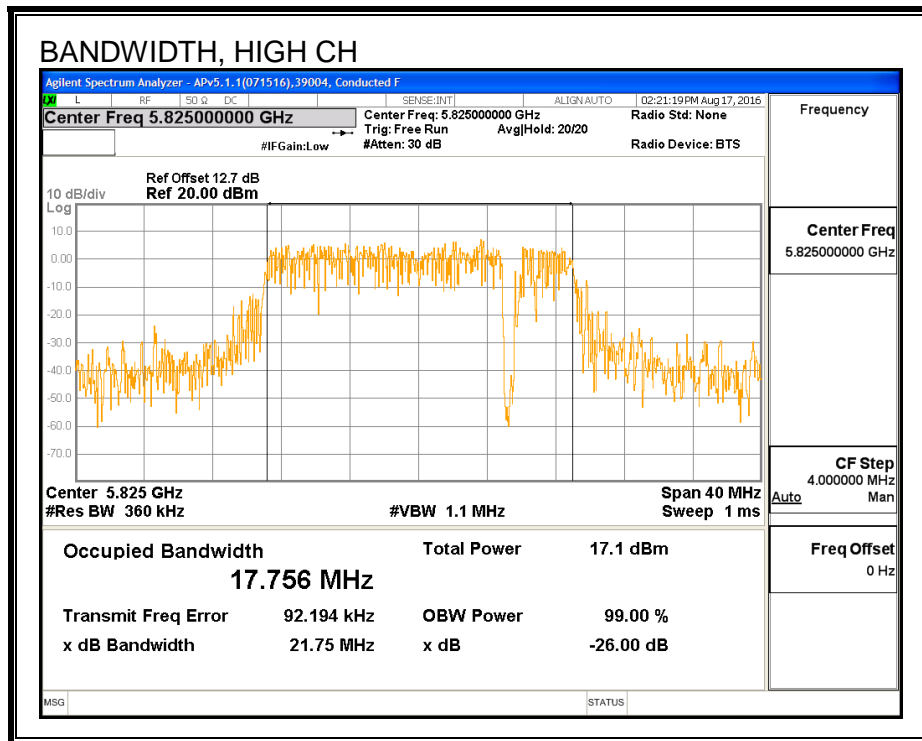

8.2.4. AVERAGE POWER (FCC/IC)

LIMITS

None; for reporting purposes only.

TEST PROCEDURE

Measurements perform using a wideband gated RF power meter.

RESULTS

ID:	30554	Date:	9/12/16
------------	-------	--------------	---------

Channel	Frequency (MHz)	Power (dBm)
Low	5745	12.68
Mid	5785	12.66
High	5825	12.62

8.2.5. OUTPUT POWER (FCC/IC)

LIMITS

FCC §15.407 (a) (3)

For the band 5.725-5.85 GHz, the maximum conducted output power over the frequency band of operation shall not exceed 1 W. In addition, the maximum power spectral density shall not exceed 30 dBm in any 500-kHz band. If transmitting antennas of directional gain greater than 6 dBi are used, both the maximum conducted output power and the maximum power spectral density shall be reduced by the amount in dB that the directional gain of the antenna exceeds 6 dBi.

IC RSS-247 (6.2.4) (1)

For the band 5.725-5.85 GHz, the maximum conducted output power over the frequency band of operation shall not exceed 1 W. In addition, the maximum power spectral density shall not exceed 30 dBm in any 500-kHz band. If transmitting antennas of directional gain greater than 6 dBi are used, both the maximum conducted output power and the maximum power spectral density shall be reduced by the amount in dB that the directional gain of the antenna exceeds 6 dBi.

TEST PROCEDURE

Measurements perform using a wideband gated RF power meter provided that the gate parameters are adjusted such that the power is measured only when the EUT is transmitting at its maximum power control level. Since the measurement is made only during the ON time of the transmitter, no duty cycle correction factor is required.

DIRECTIONAL ANTENNA GAIN

There is only one transmitter output therefore the directional gain is equal to the antenna gain.

RESULTS

ID:	30554	Date:	9/12/16
------------	-------	--------------	---------

Antenna Gain and Limit

Channel	Frequency (MHz)	Directional Gain for Power (dBi)	Power Limit (dBm)
Low	5745	6.30	29.70
Mid	5785	6.30	29.70
High	5825	6.30	29.70

Output Power Results

Channel	Frequency (MHz)	Chain 1 Meas Power (dBm)	Total Corr'd Power (dBm)	Power Limit (dBm)	Power Margin (dB)
Low	5745	12.68	12.68	29.70	-17.02
Mid	5785	12.66	12.66	29.70	-17.04
High	5825	12.62	12.62	29.70	-17.08

8.2.6. PSD (FCC/IC)

LIMITS

FCC §15.407 (a) (3)

For the band 5.725-5.85 GHz, the maximum conducted output power over the frequency band of operation shall not exceed 1 W. In addition, the maximum power spectral density shall not exceed 30 dBm in any 500-kHz band. If transmitting antennas of directional gain greater than 6 dBi are used, both the maximum conducted output power and the maximum power spectral density shall be reduced by the amount in dB that the directional gain of the antenna exceeds 6 dBi.

IC RSS-247 (6.2.4) (1)

For the band 5.725-5.85 GHz, the maximum conducted output power over the frequency band of operation shall not exceed 1 W. In addition, the maximum power spectral density shall not exceed 30 dBm in any 500-kHz band. If transmitting antennas of directional gain greater than 6 dBi are used, both the maximum conducted output power and the maximum power spectral density shall be reduced by the amount in dB that the directional gain of the antenna exceeds 6 dBi.

DIRECTIONAL ANTENNA GAIN

There is only one transmitter output therefore the directional gain is equal to the antenna gain.

RESULTS

Antenna Gain and Limits

Channel	Frequency (MHz)	Directional Gain (dBi)	PSD Limit (dBm)
Low	5745	6.30	29.70
Mid	5785	6.30	29.70
High	5825	6.30	29.70

Duty Cycle CF (dB)	0.00	Included in Calculations of Corr'd PSD
---------------------------	------	---

PSD Results

Channel	Frequency (MHz)	Chain 1 Meas PSD (dBm)	Total Corr'd PSD (dBm)	PSD Limit (dBm)	PSD Margin (dB)
Low	5745	-1.41	-1.41	29.70	-31.11
Mid	5785	-1.20	-1.20	29.70	-30.90
High	5825	-1.66	-1.66	29.70	-31.36

PSD

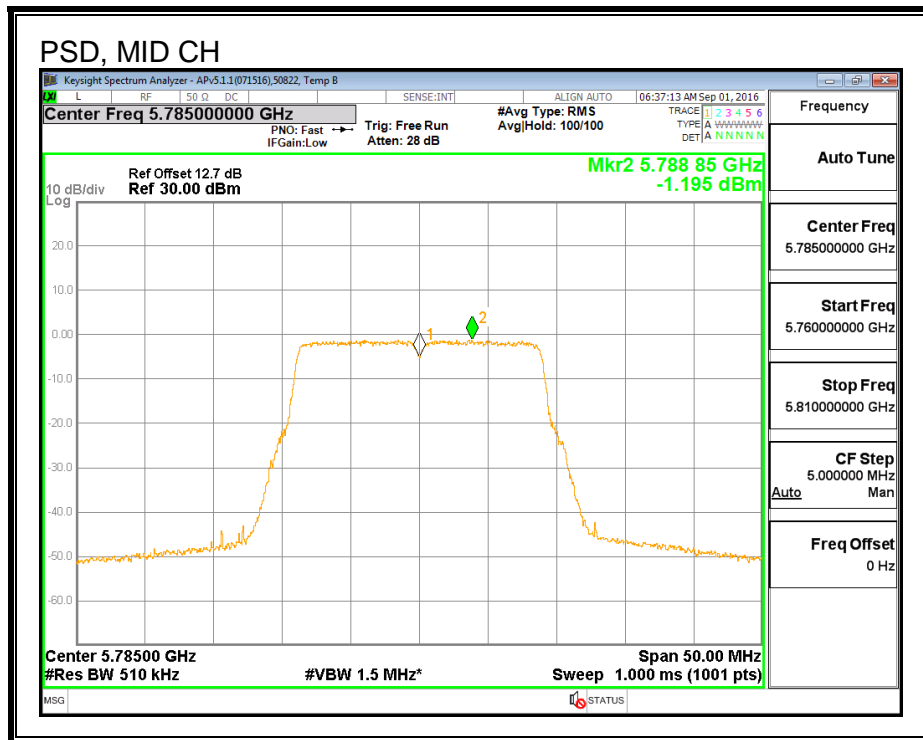
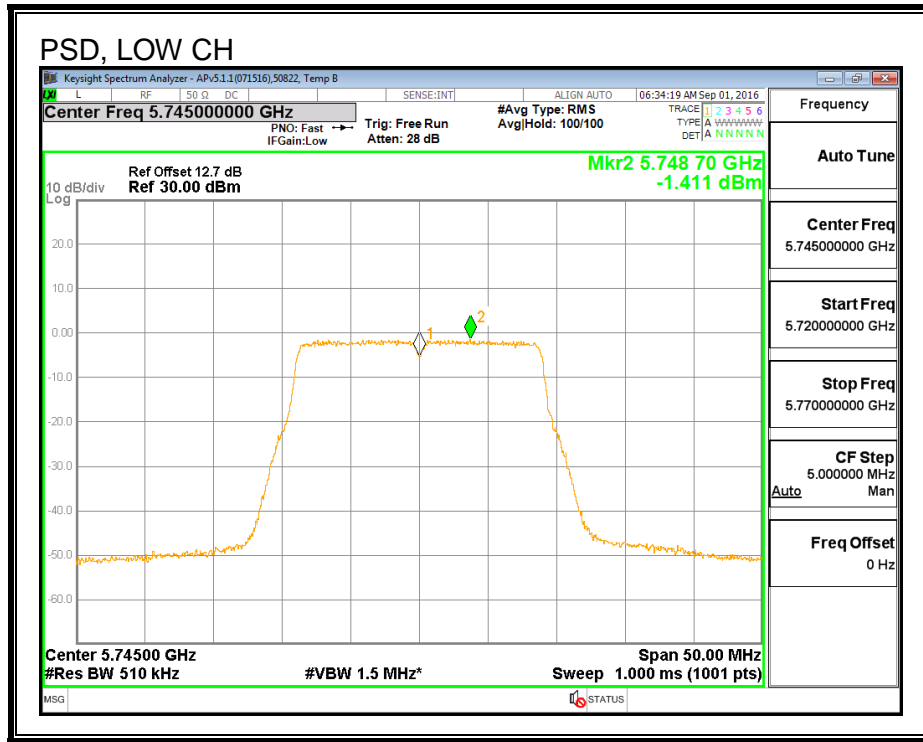

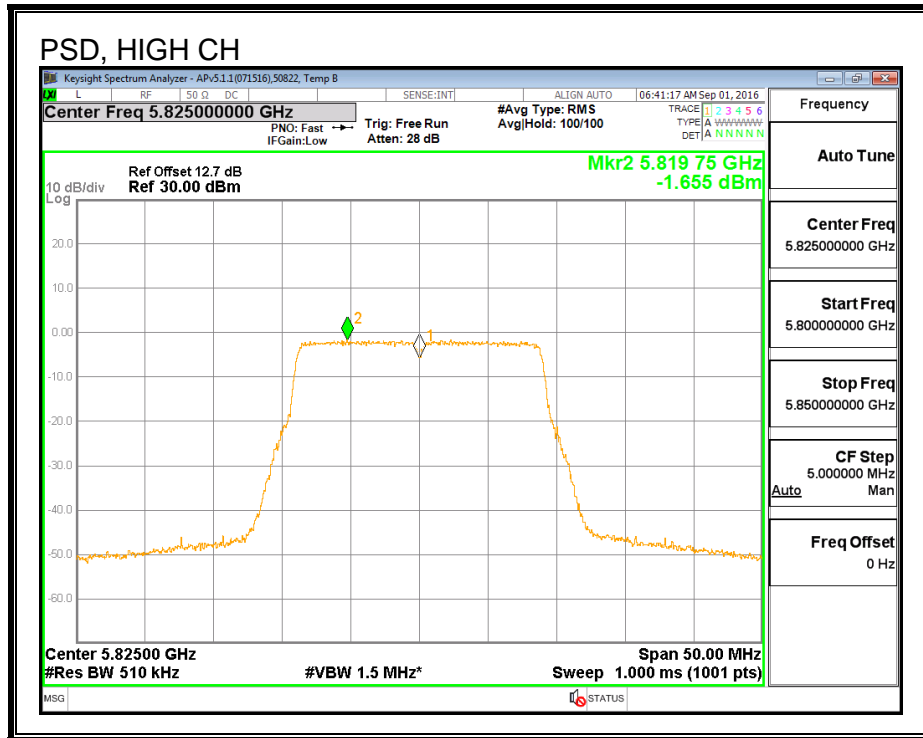

8.3. 802.11n HT20 CHAIN 2 MODE IN THE 5.8 GHz BAND

8.3.1. 6 dB BANDWIDTH

LIMITS

FCC §15.407 (e)

The minimum 6 dB bandwidth shall be at least 500 kHz.

RESULTS

Channel	Frequency (MHz)	6 dB Bandwidth (MHz)	Minimum Limit (MHz)
Low	5745	17.793	0.5
Mid	5785	17.712	0.5
High	5825	17.631	0.5

6 dB BANDWIDTH

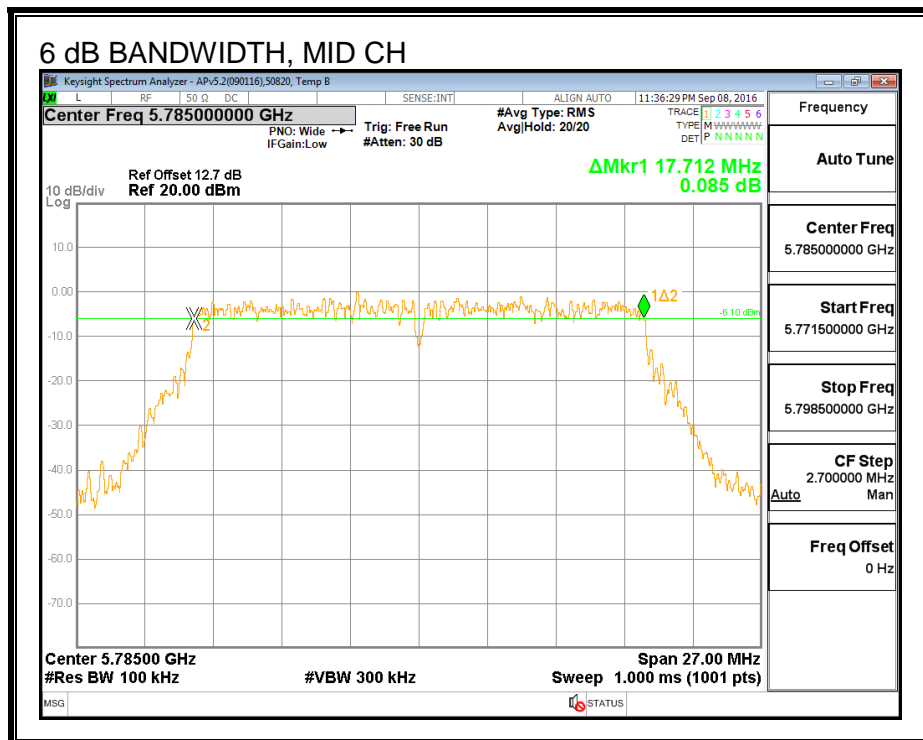
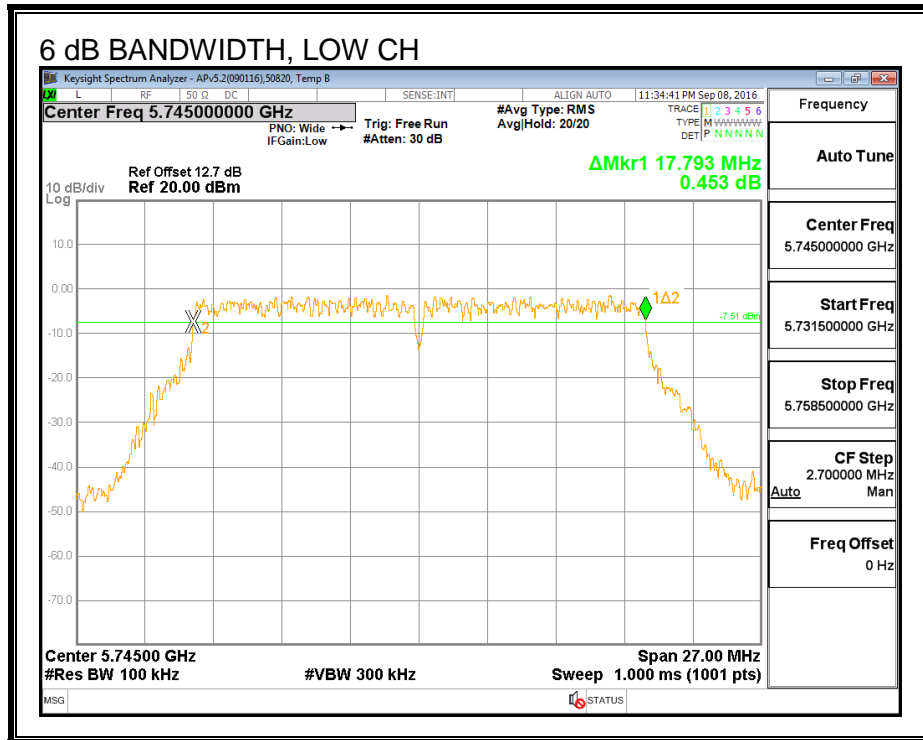

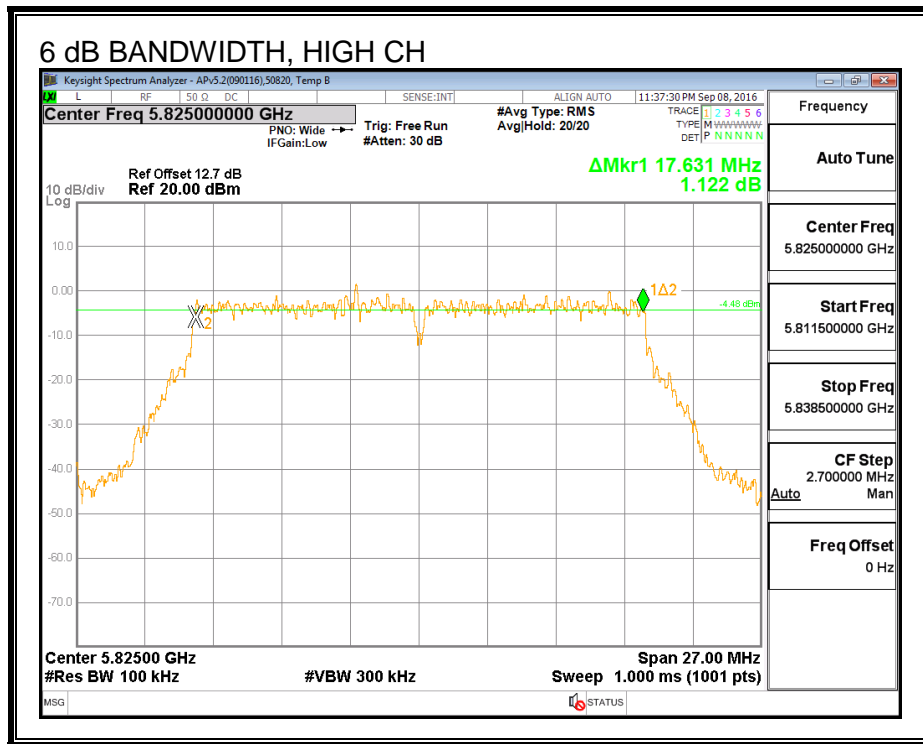

8.3.2. 26 dB BANDWIDTH

LIMITS

None, for reporting purposes only

RESULTS

Channel	Frequency (MHz)	26 dB Bandwidth (MHz)
Low	5745	21.912
Mid	5785	21.978
High	5825	22.202

26 dB BANDWIDTH

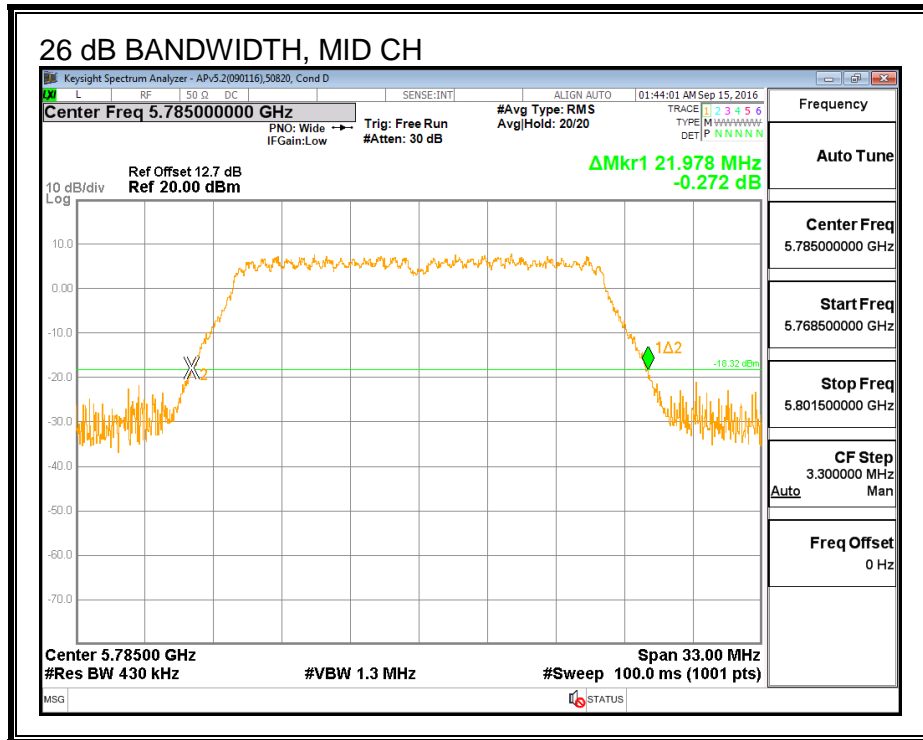
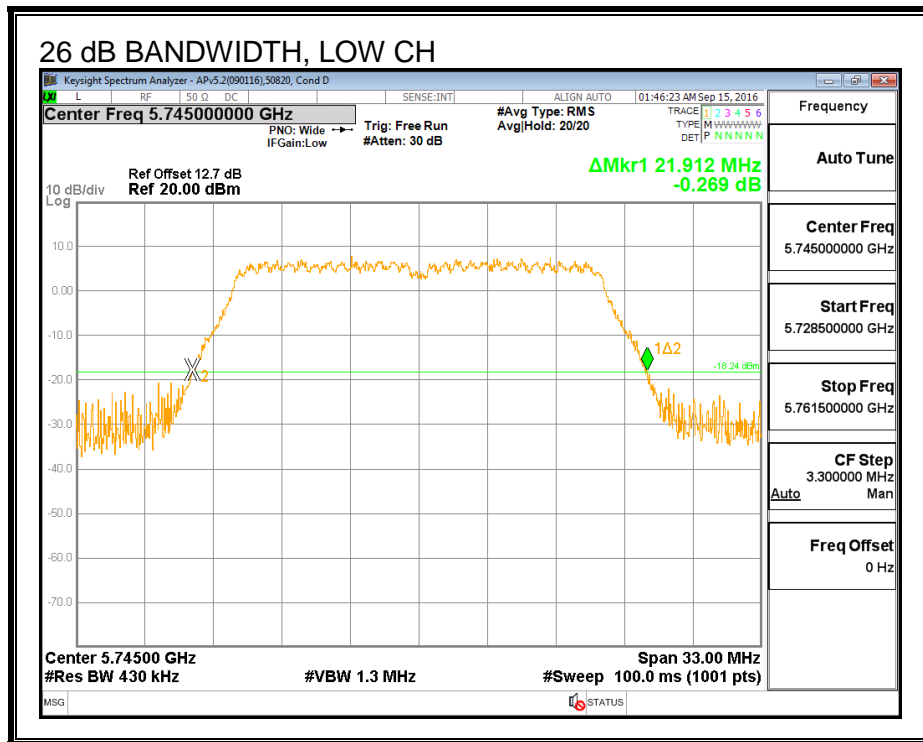

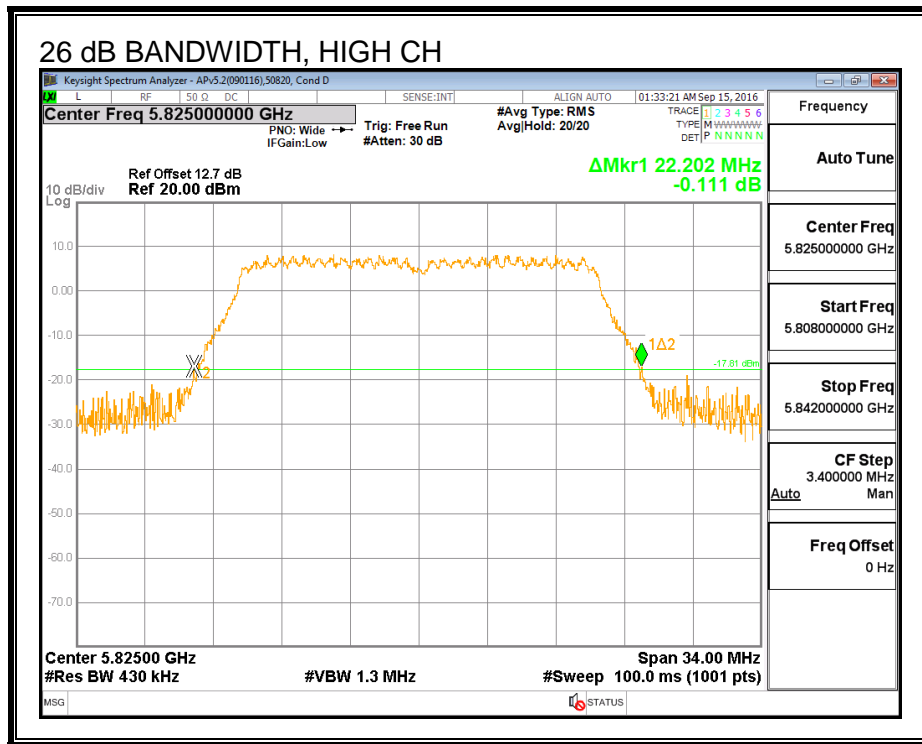

8.3.3. 99% BANDWIDTH

LIMITS

None; for reporting purposes only.

RESULTS

Channel	Frequency (MHz)	99% Bandwidth (MHz)
Low	5745	17.775
Mid	5785	17.183
High	5825	17.863

99% BANDWIDTH

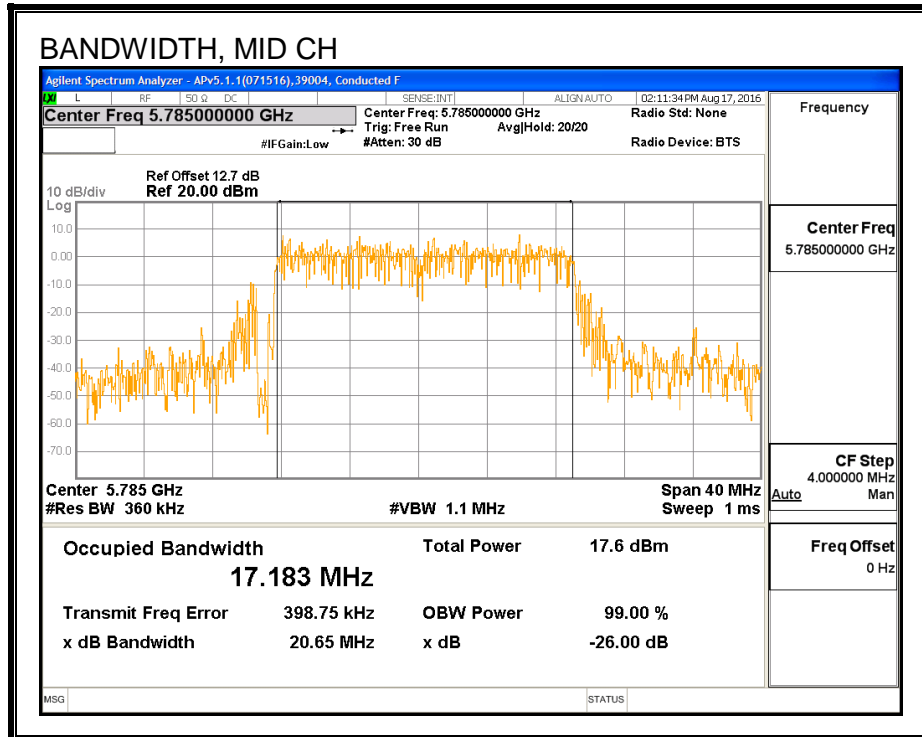
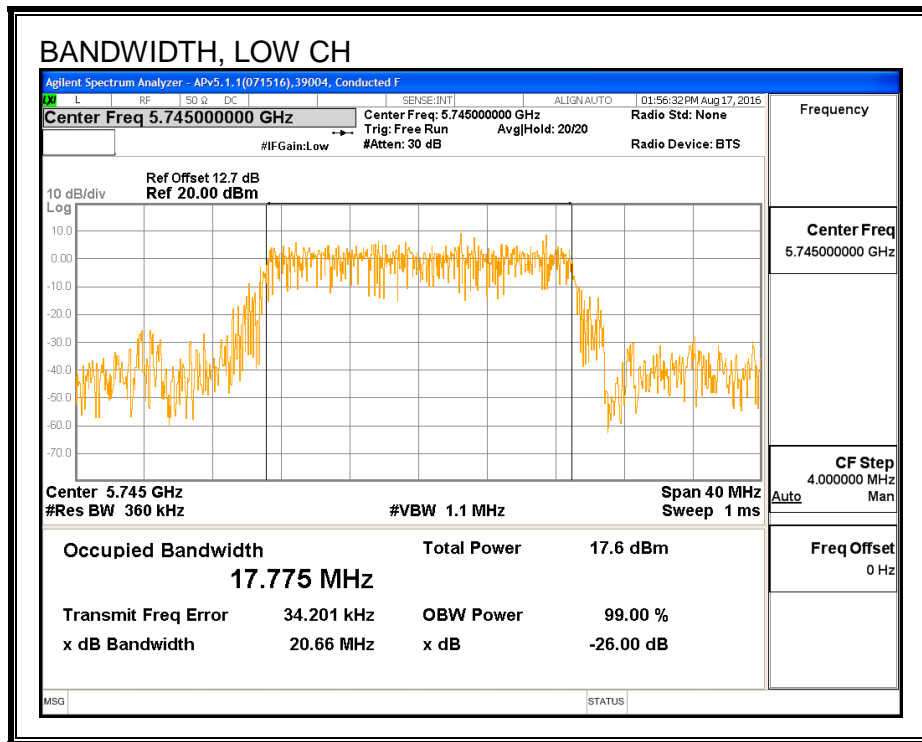

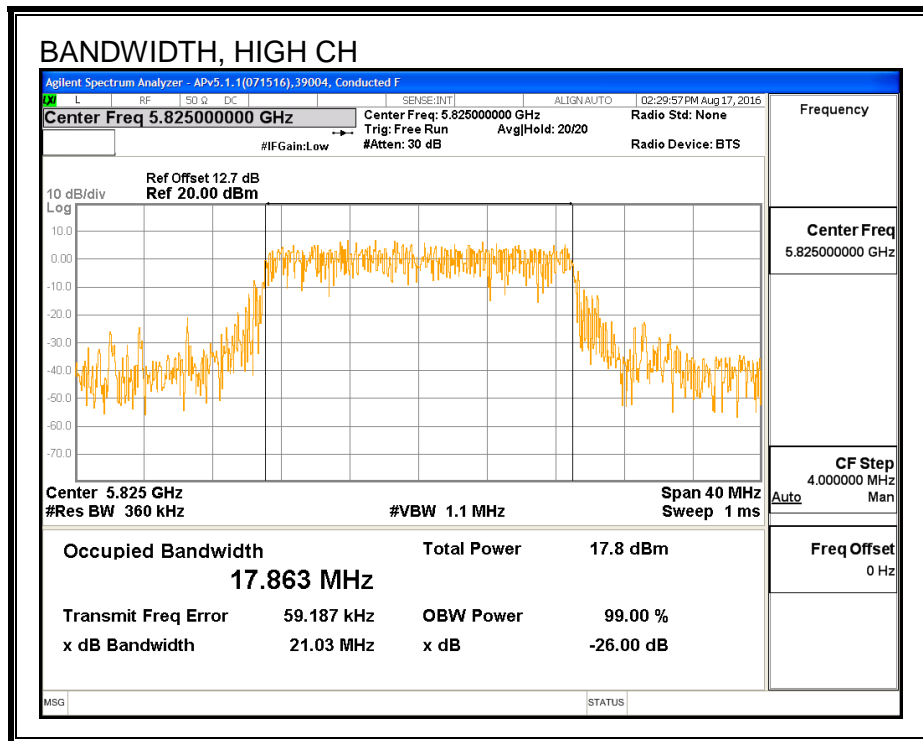

8.3.4. AVERAGE POWER (FCC/IC)

LIMITS

None; for reporting purposes only.

TEST PROCEDURE

Measurements perform using a wideband gated RF power meter.

RESULTS

ID:	30554	Date:	9/12/16
------------	-------	--------------	---------

Channel	Frequency (MHz)	Power (dBm)
Low	5745	12.58
Mid	5785	12.61
High	5825	12.64

8.3.5. OUTPUT POWER (FCC/IC)

LIMITS

FCC §15.407 (a) (3)

For the band 5.725-5.85 GHz, the maximum conducted output power over the frequency band of operation shall not exceed 1 W. In addition, the maximum power spectral density shall not exceed 30 dBm in any 500-kHz band. If transmitting antennas of directional gain greater than 6 dBi are used, both the maximum conducted output power and the maximum power spectral density shall be reduced by the amount in dB that the directional gain of the antenna exceeds 6 dBi.

IC RSS-247 (6.2.4) (1)

For the band 5.725-5.85 GHz, the maximum conducted output power over the frequency band of operation shall not exceed 1 W. In addition, the maximum power spectral density shall not exceed 30 dBm in any 500-kHz band. If transmitting antennas of directional gain greater than 6 dBi are used, both the maximum conducted output power and the maximum power spectral density shall be reduced by the amount in dB that the directional gain of the antenna exceeds 6 dBi.

TEST PROCEDURE

Measurements perform using a wideband gated RF power meter provided that the gate parameters are adjusted such that the power is measured only when the EUT is transmitting at its maximum power control level. Since the measurement is made only during the ON time of the transmitter, no duty cycle correction factor is required.

DIRECTIONAL ANTENNA GAIN

There is only one transmitter output therefore the directional gain is equal to the antenna gain.

RESULTS

ID:	30554	Date:	9/12/16
------------	-------	--------------	---------

Antenna Gain and Limit

Channel	Frequency (MHz)	Directional Gain for Power (dBi)	Power Limit (dBm)
Low	5745	4.70	30.00
Mid	5785	4.70	30.00
High	5825	4.70	30.00

Output Power Results

Channel	Frequency (MHz)	Chain 2 Meas Power (dBm)	Total Corr'd Power (dBm)	Power Limit (dBm)	Power Margin (dB)
Low	5745	12.58	12.58	30.00	-17.42
Mid	5785	12.61	12.61	30.00	-17.39
High	5825	12.64	12.64	30.00	-17.36

8.3.6. PSD (FCC/IC)

LIMITS

FCC §15.407 (a) (3)

For the band 5.725-5.85 GHz, the maximum conducted output power over the frequency band of operation shall not exceed 1 W. In addition, the maximum power spectral density shall not exceed 30 dBm in any 500-kHz band. If transmitting antennas of directional gain greater than 6 dBi are used, both the maximum conducted output power and the maximum power spectral density

IC RSS-247 (6.2.4) (1)

For the band 5.725-5.85 GHz, the maximum conducted output power over the frequency band of operation shall not exceed 1 W. In addition, the maximum power spectral density shall not exceed 30 dBm in any 500-kHz band. If transmitting antennas of directional gain greater than 6 dBi are used, both the maximum conducted output power and the maximum power spectral density shall be reduced by the amount in dB that the directional gain of the antenna exceeds 6 dBi.

shall be reduced by the amount in dB that the directional gain of the antenna exceeds 6 dBi.

DIRECTIONAL ANTENNA GAIN

There is only one transmitter output therefore the directional gain is equal to the antenna gain.

RESULTS

Antenna Gain and Limits

Channel	Frequency (MHz)	Directional Gain (dBi)	PSD Limit (dBm)
Low	5745	4.70	30.00
Mid	5785	4.70	30.00
High	5825	4.70	30.00

Duty Cycle CF (dB)	0.00	Included in Calculations of Corr'd PSD
---------------------------	------	---

PSD Results

Channel	Frequency (MHz)	Chain 2 Meas PSD (dBm)	Total Corr'd PSD (dBm)	PSD Limit (dBm)	PSD Margin (dB)
Low	5745	-1.24	-1.24	30.00	-31.24
Mid	5785	-1.28	-1.28	30.00	-31.28
High	5825	-1.52	-1.52	30.00	-31.52

PSD

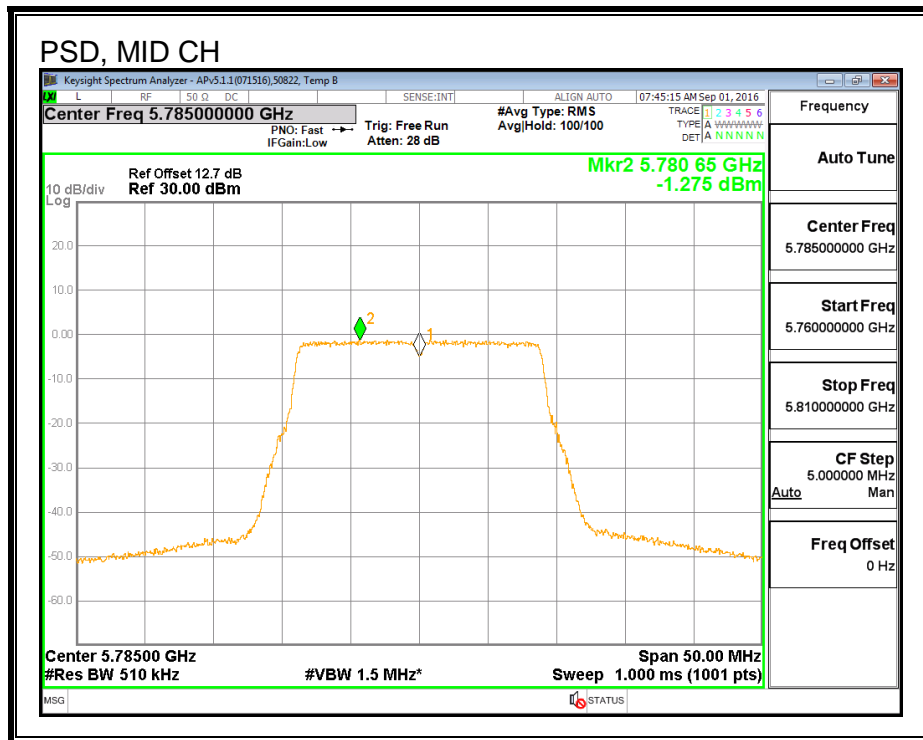
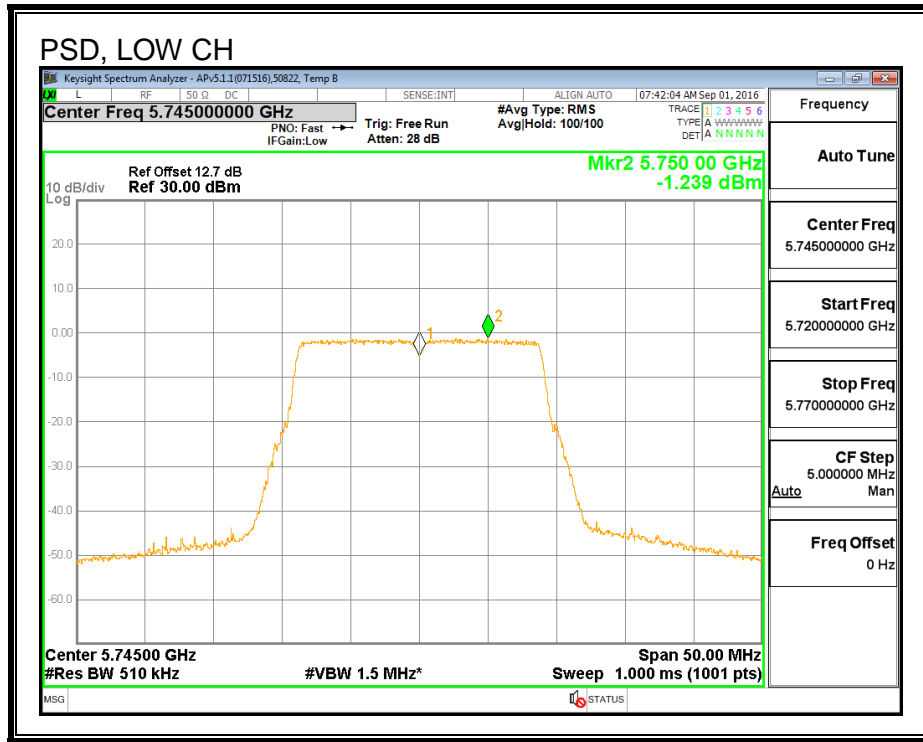

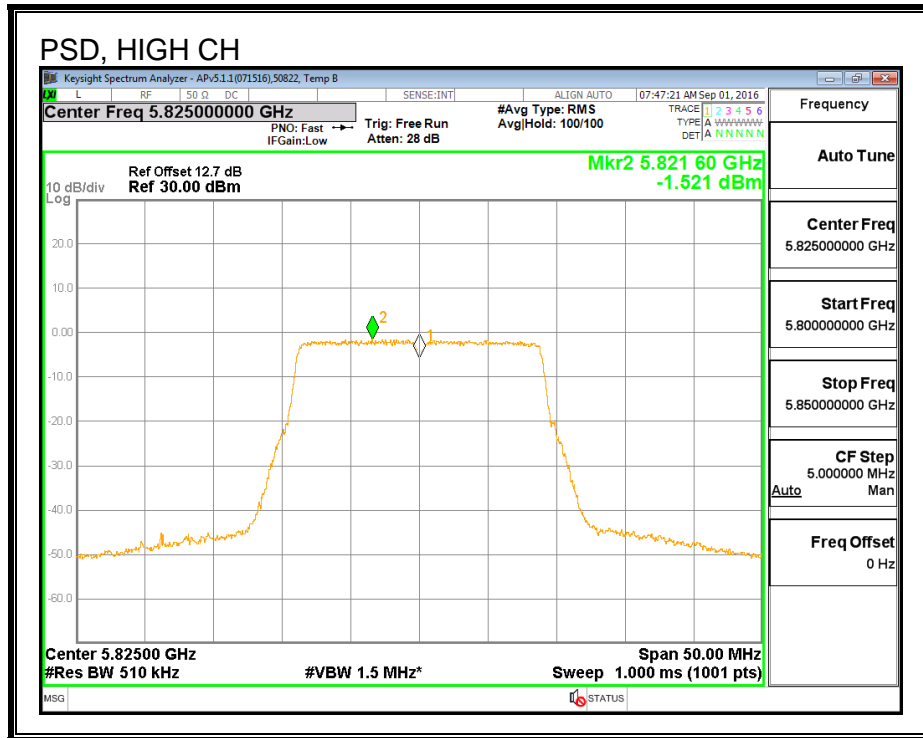

8.4. 802.11n HT20 2Tx (CHAIN 0 + CHAIN 1) CDD MODE IN THE 5.8 GHz BAND

8.4.1. 6 dB BANDWIDTH

LIMITS

FCC §15.407 (e)

The minimum 6 dB bandwidth shall be at least 500 kHz.

RESULTS

Channel	Frequency (MHz)	6 dB BW Chain 0 (MHz)	6 dB BW Chain 1 (MHz)	Minimum Limit (MHz)
Low	5745	17.712	17.847	0.5
Mid	5785	17.793	17.793	0.5
High	5825	17.577	17.712	0.5

6 dB BANDWIDTH, CHAIN 0

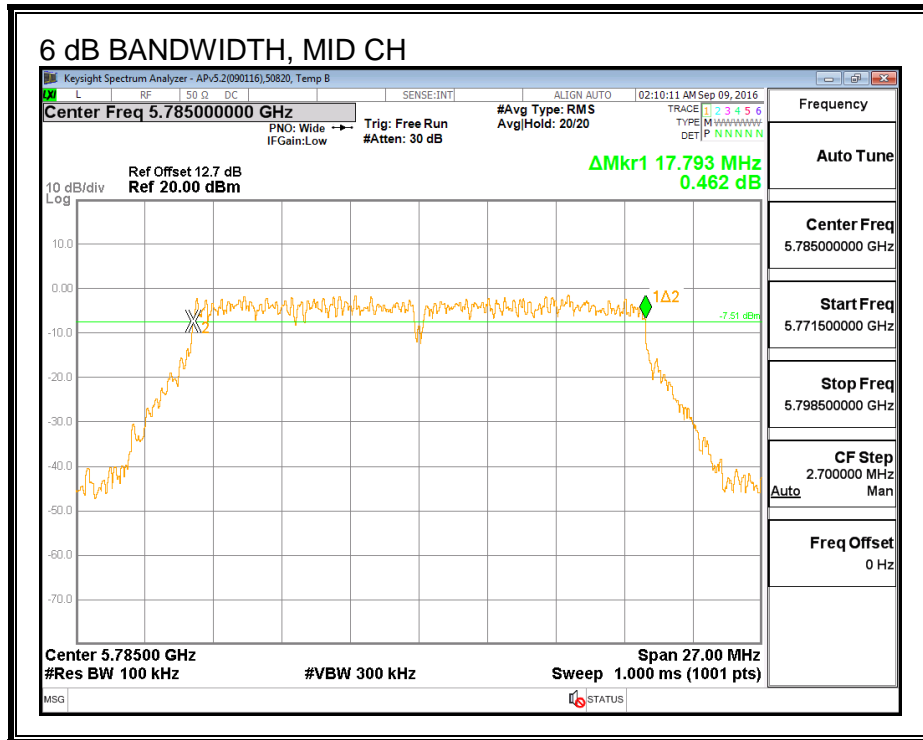
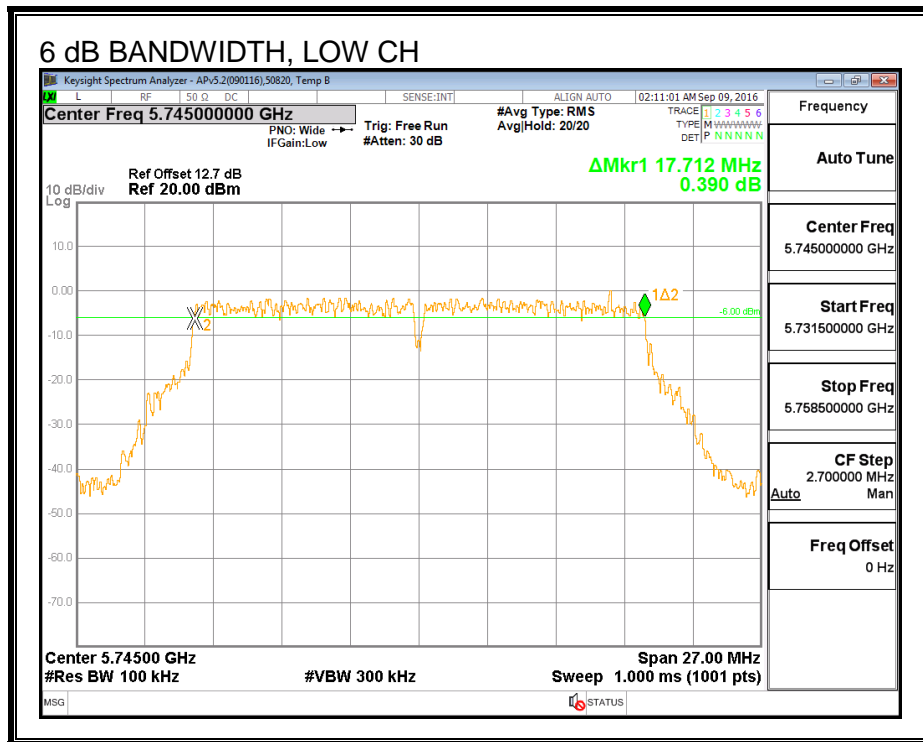

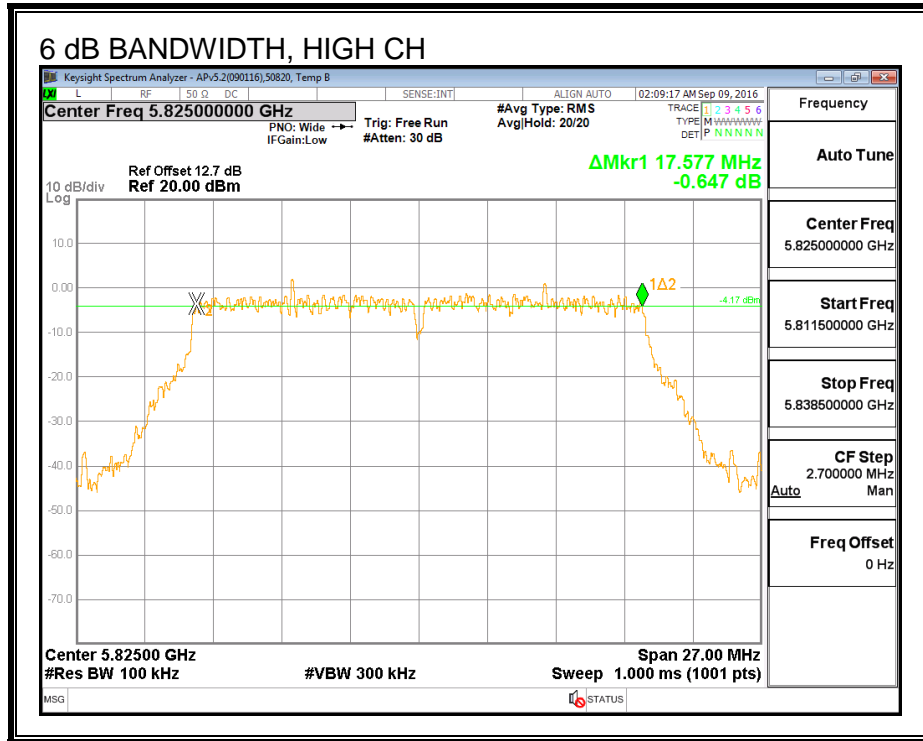

6 dB BANDWIDTH, CHAIN 1

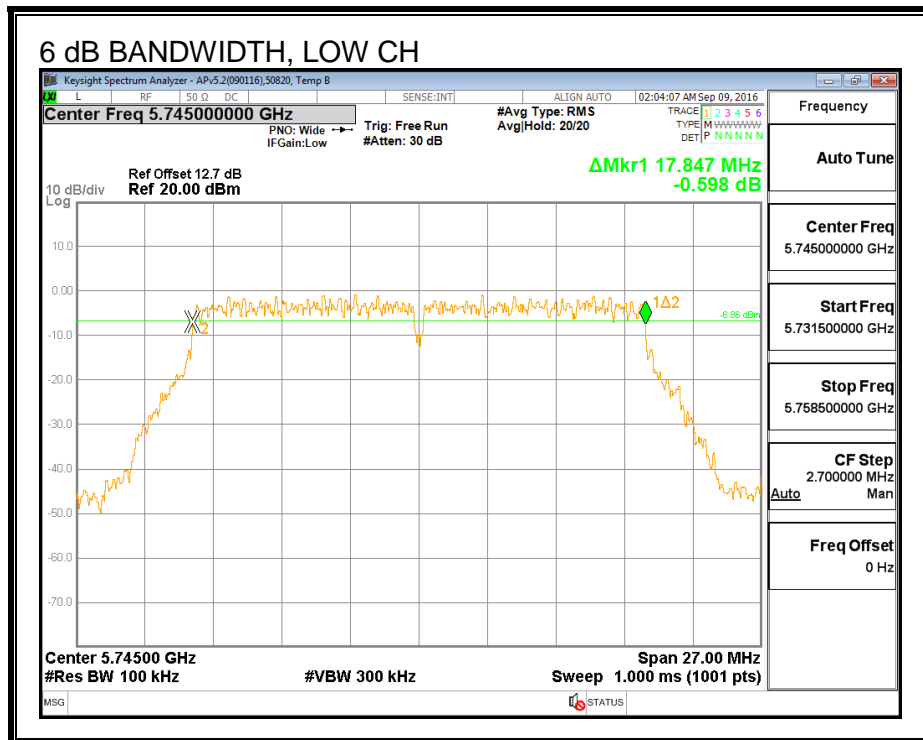

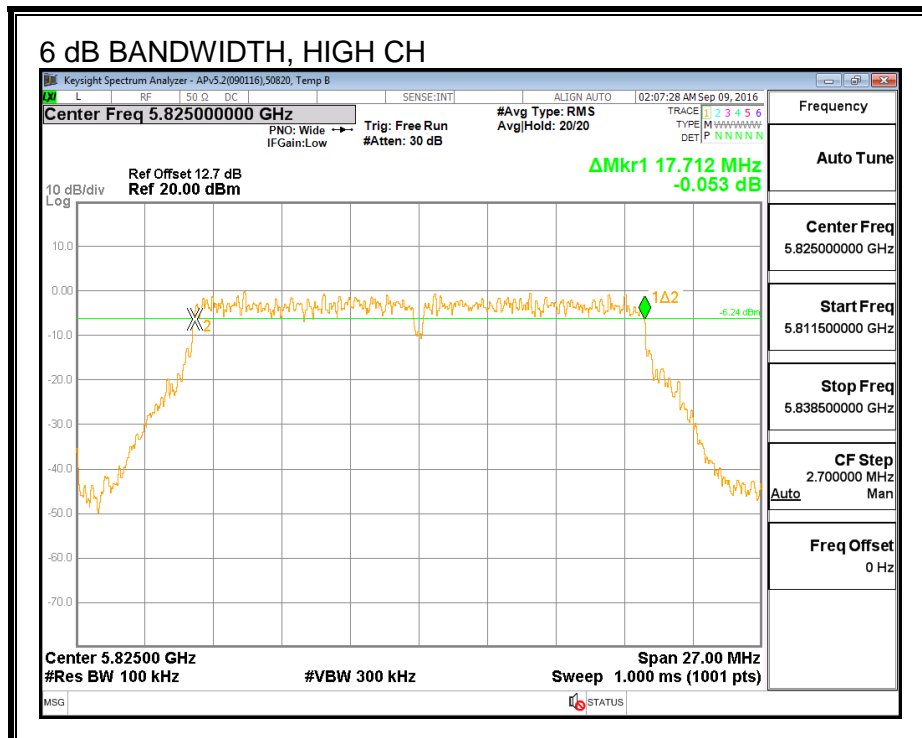
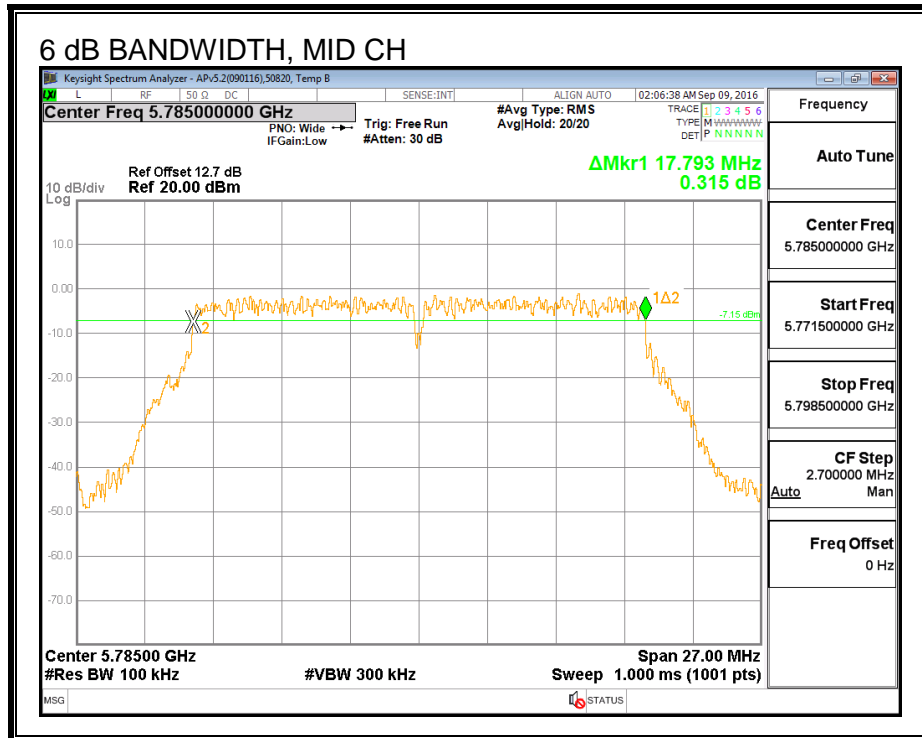

8.4.2. 26 dB BANDWIDTH

LIMITS

None, for reporting purposes only.

RESULTS

Channel	Frequency (MHz)	26 dB BW Chain 0 (MHz)	26 dB BW Chain 1 (MHz)
Low	5745	22.134	21.780
Mid	5785	22.134	21.813
High	5825	22.304	21.813

26 dB BANDWIDTH, CHAIN 0

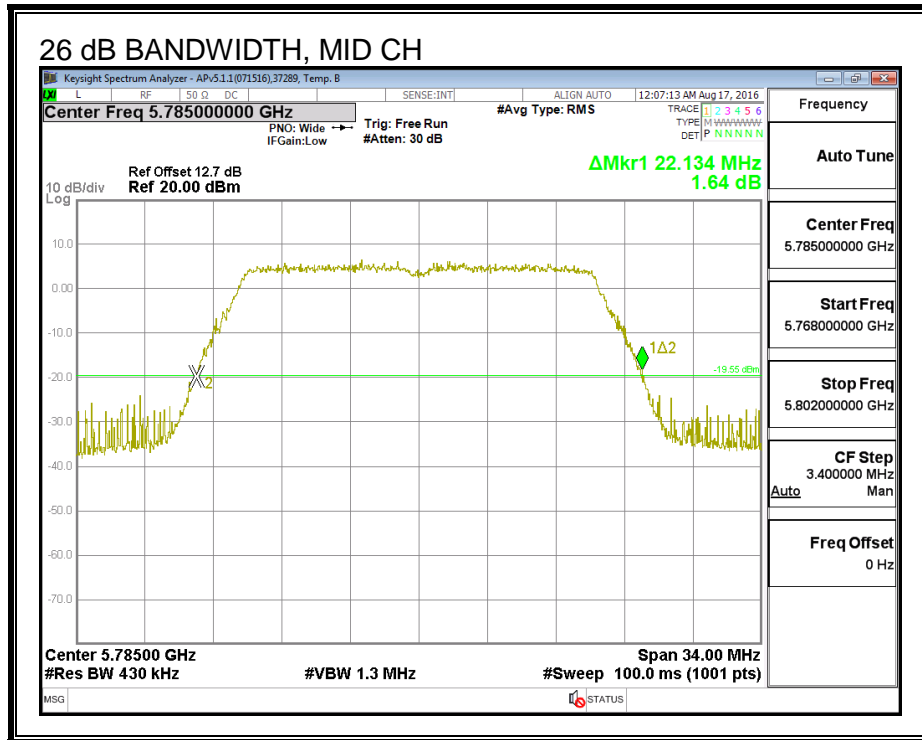
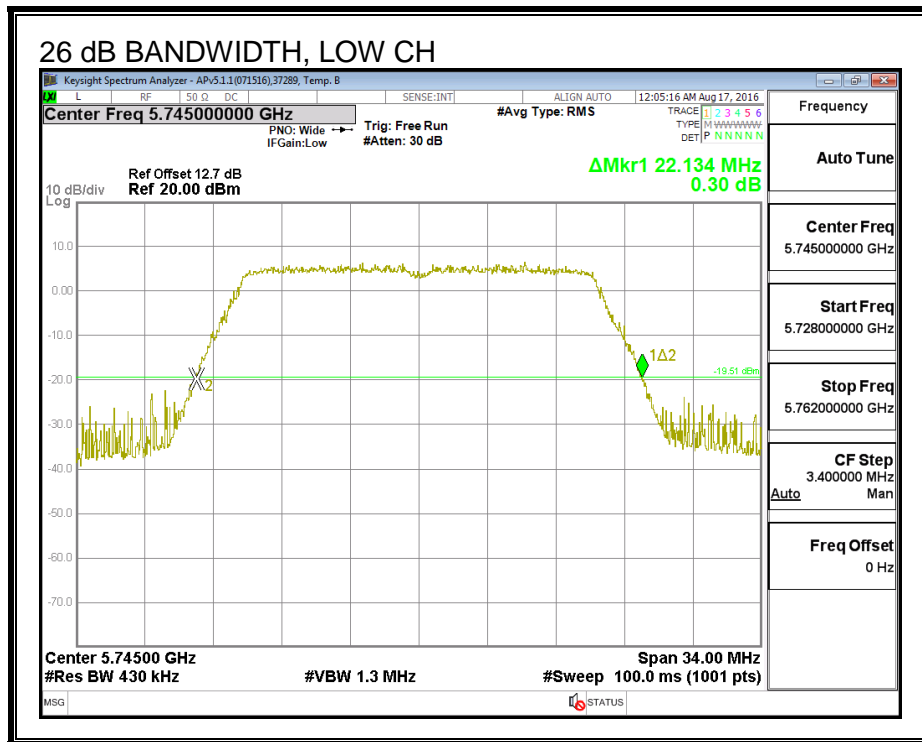

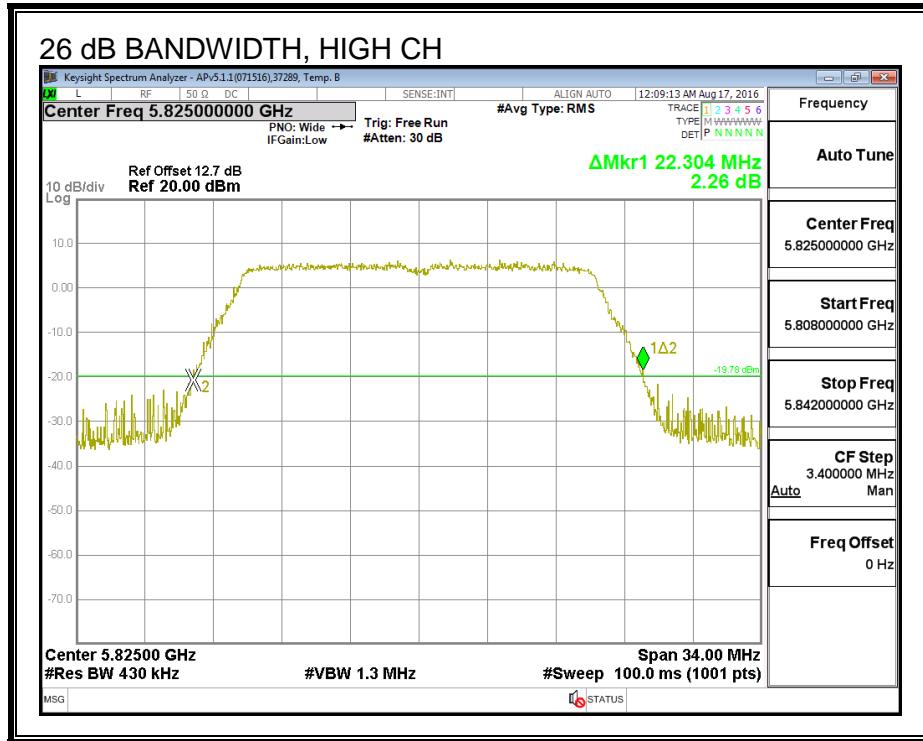

26 dB BANDWIDTH, CHAIN 1

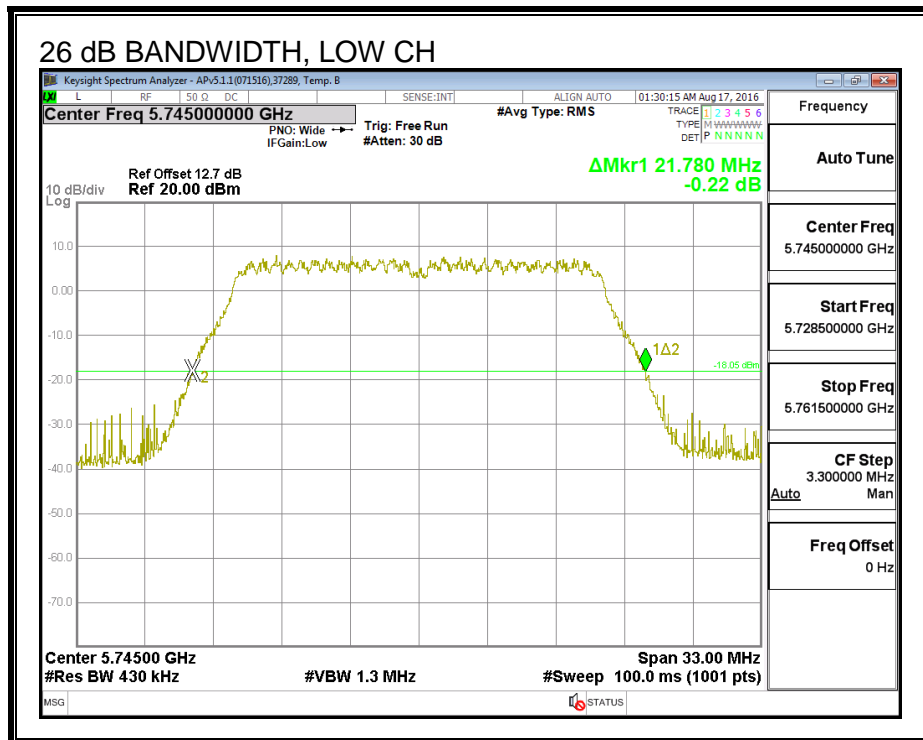

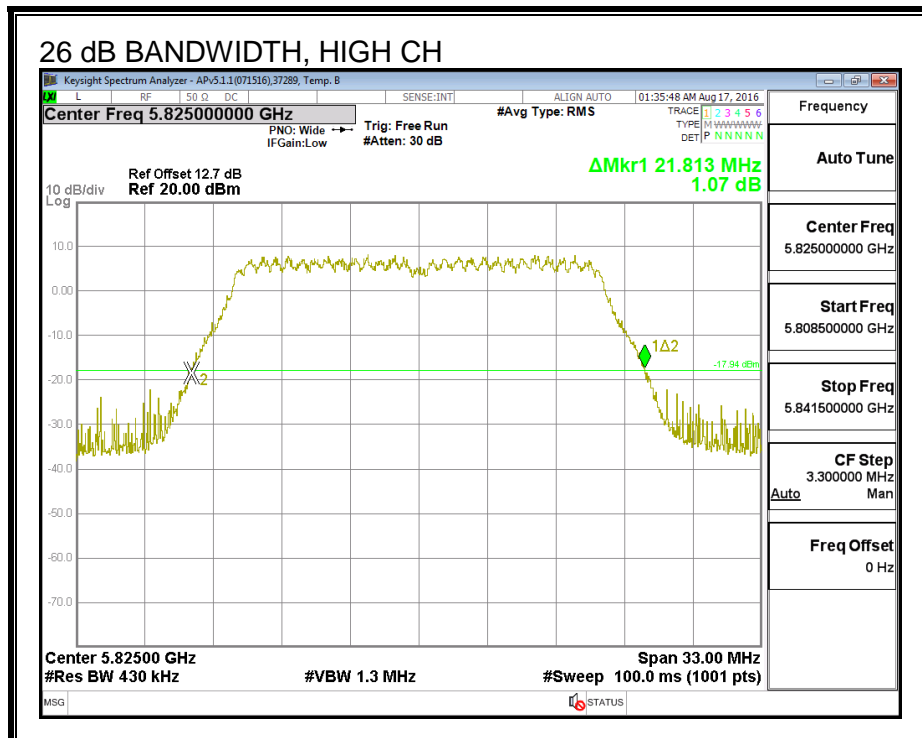
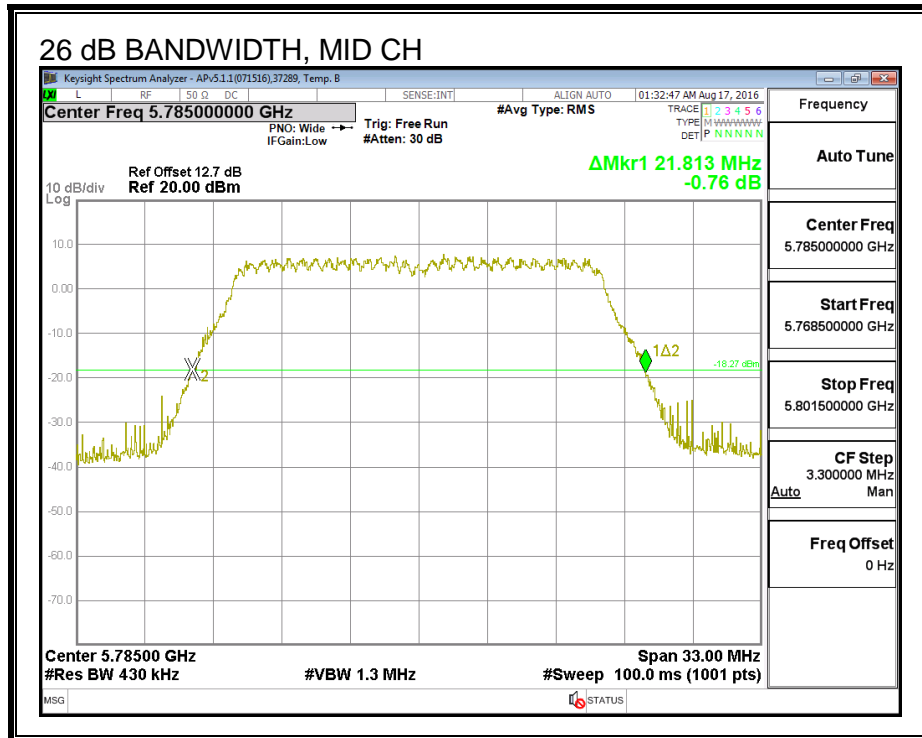

8.4.3. 99% BANDWIDTH

LIMITS

None; for reporting purposes only.

RESULTS

Channel	Frequency (MHz)	99% BW Chain 0 (MHz)	99% BW Chain 1 (MHz)
Low	5745	17.791	17.811
Mid	5785	17.729	17.706
High	5825	17.817	17.767

99% BANDWIDTH, CHAIN 0

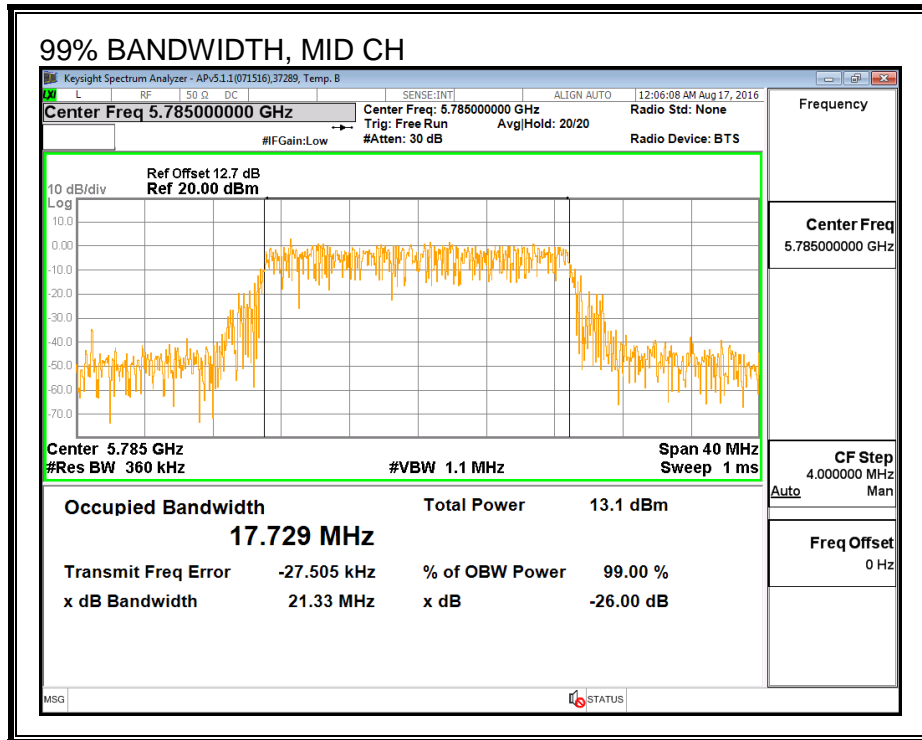
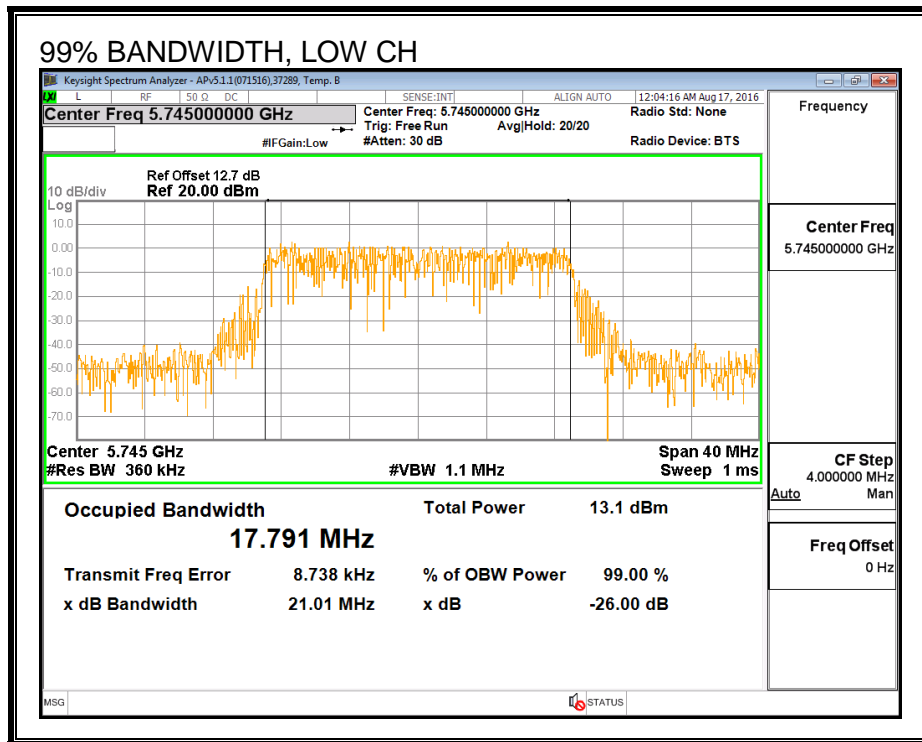

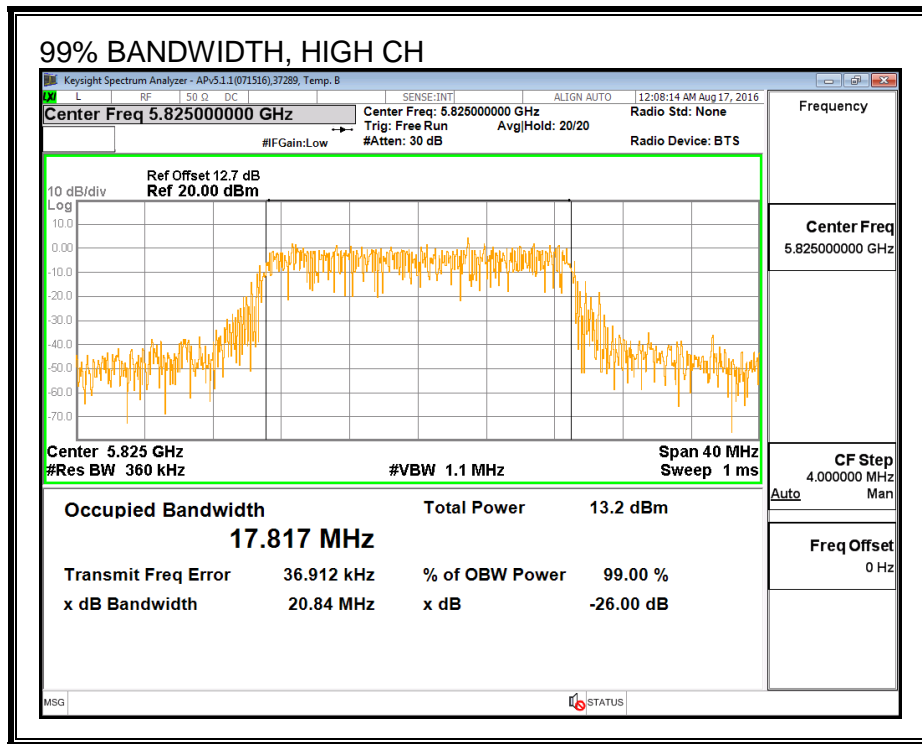

99% BANDWIDTH, CHAIN 1

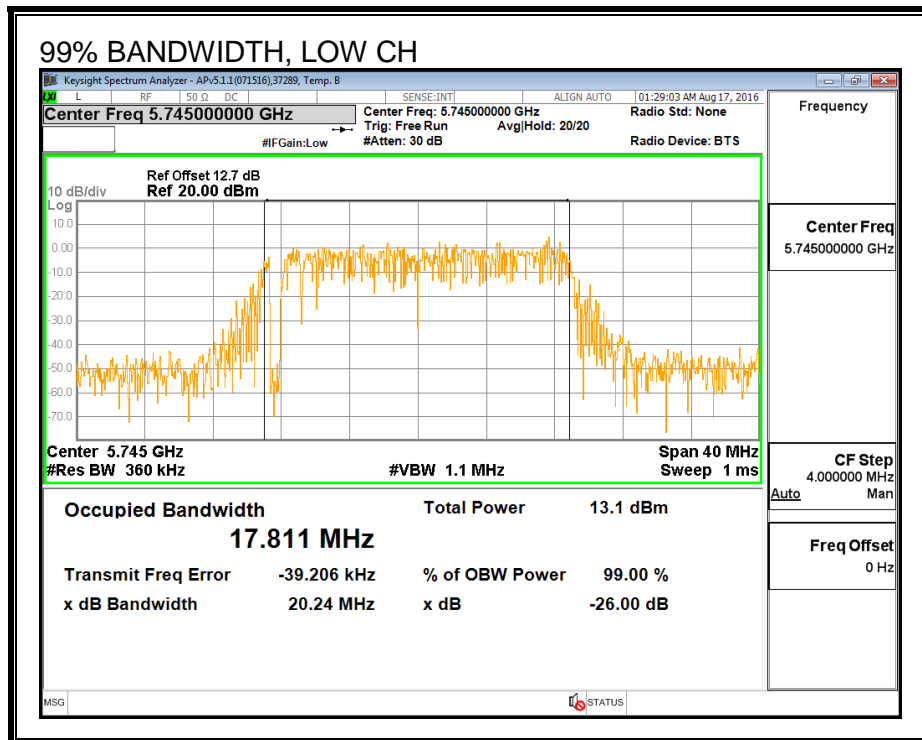

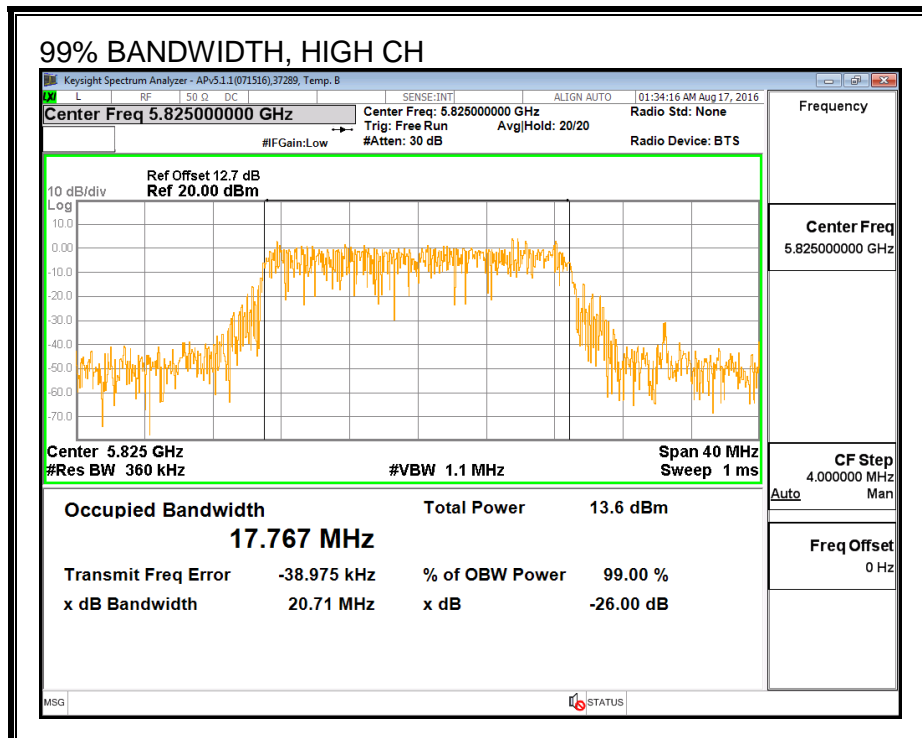
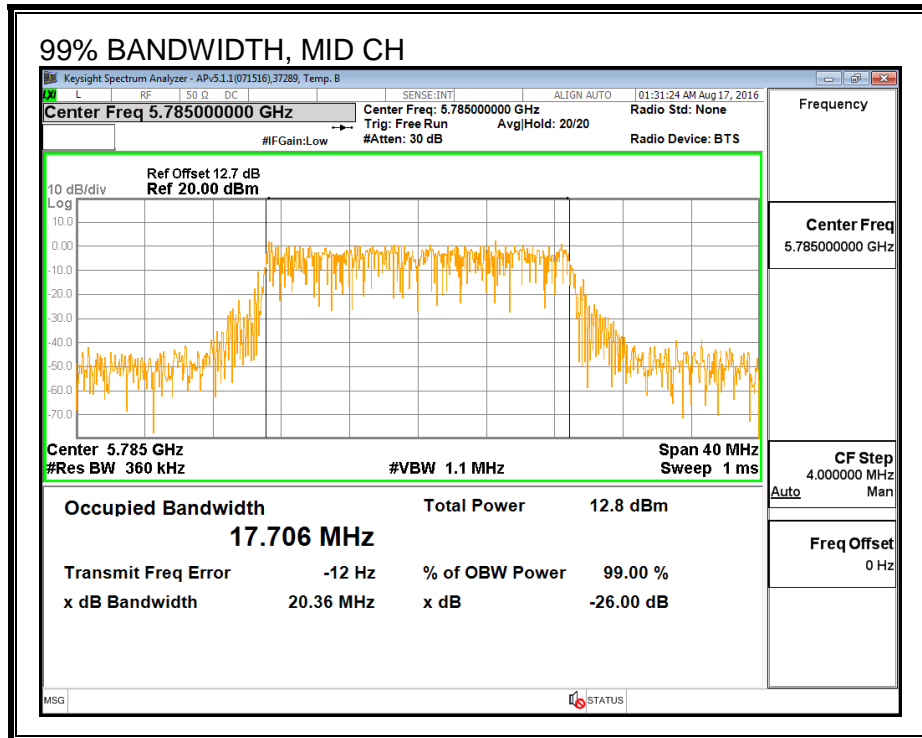

8.4.4. AVERAGE POWER (FCC/IC)

LIMITS

None; for reporting purposes only.

TEST PROCEDURE

Measurements perform using a wideband gated RF power meter.

RESULTS

ID:	43573	Date:	9/7/16
------------	-------	--------------	--------

Channel	Frequency (MHz)	Chain 0 Power (dBm)	Chain 1 Power (dBm)	Total Power (dBm)
Low	5745	12.65	12.62	15.65
Mid	5785	12.66	12.70	15.69
High	5825	12.67	12.67	15.68

8.4.5. OUTPUT POWER (FCC/IC)

LIMITS

FCC §15.407 (a) (3)

For the band 5.725-5.85 GHz, the maximum conducted output power over the frequency band of operation shall not exceed 1 W. In addition, the maximum power spectral density shall not exceed 30 dBm in any 500-kHz band. If transmitting antennas of directional gain greater than 6 dBi are used, both the maximum conducted output power and the maximum power spectral density shall be reduced by the amount in dB that the directional gain of the antenna exceeds 6 dBi.

IC RSS-247 (6.2.4) (1)

For the band 5.725-5.85 GHz, the maximum conducted output power over the frequency band of operation shall not exceed 1 W. In addition, the maximum power spectral density shall not exceed 30 dBm in any 500-kHz band. If transmitting antennas of directional gain greater than 6 dBi are used, both the maximum conducted output power and the maximum power spectral density shall be reduced by the amount in dB that the directional gain of the antenna exceeds 6 dBi.

TEST PROCEDURE

Measurements perform using a wideband gated RF power meter provided that the gate parameters are adjusted such that the power is measured only when the EUT is transmitting at its maximum power control level. Since the measurement is made only during the ON time of the transmitter, no duty cycle correction factor is required.

DIRECTIONAL ANTENNA GAIN

The TX chains are uncorrelated and the antenna gain is unequal among the chains. The directional gain is:

Chain 0 Antenna Gain (dBi)	Chain 1 Antenna Gain (dBi)	Uncorrelated Chains Directional Gain (dBi)
4.00	6.30	5.30

RESULTS

ID:	43573	Date:	9/7/16
------------	-------	--------------	--------

Antenna Gain and Limit

Channel	Frequency (MHz)	Directional Gain for Power (dBi)	Power Limit (dBm)
Low	5745	5.30	30.00
Mid	5785	5.30	30.00
High	5825	5.30	30.00

Output Power Results

Channel	Frequency (MHz)	Chain 0 Meas Power (dBm)	Chain 1 Meas Power (dBm)	Total Corr'd Power (dBm)	Power Limit (dBm)	Power Margin (dB)
Low	5745	12.65	12.62	15.65	30.00	-14.35
Mid	5785	12.66	12.70	15.69	30.00	-14.31
High	5825	12.67	12.67	15.68	30.00	-14.32

8.4.6. PSD (FCC/IC)

LIMITS

FCC §15.407 (a) (3)

For the band 5.725-5.85 GHz, the maximum conducted output power over the frequency band of operation shall not exceed 1 W. In addition, the maximum power spectral density shall not exceed 30 dBm in any 500-kHz band. If transmitting antennas of directional gain greater than 6 dBi are used, both the maximum conducted output power and the maximum power spectral density shall be reduced by the amount in dB that the directional gain of the antenna exceeds 6 dBi.

IC RSS-247 (6.2.4) (1)

For the band 5.725-5.85 GHz, the maximum conducted output power over the frequency band of operation shall not exceed 1 W. In addition, the maximum power spectral density shall not exceed 30 dBm in any 500-kHz band. If transmitting antennas of directional gain greater than 6 dBi are used, both the maximum conducted output power and the maximum power spectral density shall be reduced by the amount in dB that the directional gain of the antenna exceeds 6 dBi.

DIRECTIONAL ANTENNA GAIN

The TX chains are correlated and the antenna gain is unequal among the chains. The directional gain is:

Chain 0 Antenna Gain (dBi)	Chain 1 Antenna Gain (dBi)	Correlated Chains Directional Gain (dBi)
4.00	6.30	8.24