



# **CERTIFICATION TEST REPORT**

**Report Number. :** 16U23816-E2V2

**Applicant :** APPLE, INC  
1 INFINITE LOOP  
CUPERTINO, CA 95014, U.S.A.

**Model :** A1671, A1821

**FCC ID :** BCGA1671

**IC :** 579C-A1671

**EUT Description :** TABLET DEVICE

**Test Standard(s) :** FCC 47 CFR PART 15 SUBPART C  
INDUSTRY CANADA RSS - 247 ISSUE 1

**Date Of Issue:**  
March 01, 2017

**Prepared by:**  
UL Verification Services Inc.  
47173 Benicia Street  
Fremont, CA 94538, U.S.A.  
TEL: (510) 771-1000  
FAX: (510) 661-0888

**NVLAP<sup>®</sup>**  
TESTING  
NVLAP LAB CODE 200065-0

---

Revision History

<u>Rev.</u>	<u>Issue Date</u>	<u>Revisions</u>	<u>Revised By</u>
V1	02/21/2017	Initial Review	Mengistu Mekuria
V2	03/01/2017	Address TCB's Question	Chin Pang

## TABLE OF CONTENTS

<b>1. ATTESTATION OF TEST RESULTS .....</b>	<b>6</b>
<b>2. TEST METHODOLOGY .....</b>	<b>7</b>
<b>3. FACILITIES AND ACCREDITATION .....</b>	<b>7</b>
<b>4. CALIBRATION AND UNCERTAINTY .....</b>	<b>8</b>
4.1. <i>MEASURING INSTRUMENT CALIBRATION .....</i>	<i>8</i>
4.2. <i>SAMPLE CALCULATION .....</i>	<i>8</i>
4.3. <i>MEASUREMENT UNCERTAINTY.....</i>	<i>8</i>
<b>5. EQUIPMENT UNDER TEST.....</b>	<b>9</b>
5.1. <i>DESCRIPTION OF EUT .....</i>	<i>9</i>
5.1. <i>DESCRIPTION OF MODELS DIFFERENCES.....</i>	<i>9</i>
5.2. <i>MAXIMUM OUTPUT POWER.....</i>	<i>9</i>
5.3. <i>DESCRIPTION OF AVAILABLE ANTENNAS .....</i>	<i>9</i>
5.4. <i>SOFTWARE AND FIRMWARE.....</i>	<i>9</i>
5.5. <i>WORST-CASE CONFIGURATION AND MODE.....</i>	<i>10</i>
5.6. <i>DESCRIPTION OF TEST SETUP.....</i>	<i>11</i>
<b>6. TEST AND MEASUREMENT EQUIPMENT .....</b>	<b>17</b>
<b>7. MEASUREMENT METHODS .....</b>	<b>18</b>
<b>8. ANTENNA PORT TEST RESULTS.....</b>	<b>19</b>
8.1. <i>ON TIME AND DUTY CYCLE.....</i>	<i>19</i>
8.1.1. <i>HIGH POWER MODE.....</i>	<i>20</i>
8.1.2. <i>LOW POWER MODE .....</i>	<i>21</i>
8.2. <i>HIGH POWER BASIC DATA RATE GFSK MODULATION.....</i>	<i>22</i>
8.2.1. <i>20 dB AND 99% BANDWIDTH .....</i>	<i>22</i>
8.2.2. <i>HOPPING FREQUENCY SEPARATION .....</i>	<i>25</i>
8.2.3. <i>NUMBER OF HOPPING CHANNELS.....</i>	<i>26</i>
8.2.4. <i>AVERAGE TIME OF OCCUPANCY .....</i>	<i>29</i>
8.2.5. <i>OUTPUT POWER .....</i>	<i>33</i>
8.2.6. <i>AVERAGE POWER.....</i>	<i>34</i>
8.2.7. <i>CONDUCTED BANDEDGE AND SPURIOUS EMISSIONS.....</i>	<i>35</i>
8.3. <i>HIGH POWER ENHANCED DATA RATE DQPSK MODULATION.....</i>	<i>39</i>
8.3.1. <i>OUTPUT POWER .....</i>	<i>39</i>
8.3.2. <i>AVERAGE POWER.....</i>	<i>40</i>
8.4. <i>HIGH POWER ENHANCED DATA RATE 8PSK MODULATION .....</i>	<i>41</i>
8.4.1. <i>20 dB AND 99% BANDWIDTH .....</i>	<i>41</i>
8.4.2. <i>HOPPING FREQUENCY SEPARATION .....</i>	<i>44</i>
8.4.3. <i>NUMBER OF HOPPING CHANNELS.....</i>	<i>45</i>

8.4.4.	AVERAGE TIME OF OCCUPANCY .....	48
8.4.5.	OUTPUT POWER .....	52
8.4.6.	AVERAGE POWER.....	53
8.4.7.	CONDUCTED BANDEDGE AND SPURIOUS EMISSIONS.....	54
8.5.	LOW POWER BASIC DATA RATE GFSK MODULATION.....	58
8.5.1.	20 dB AND 99% BANDWIDTH .....	58
8.5.2.	HOPPING FREQUENCY SEPARATION .....	61
8.5.3.	NUMBER OF HOPPING CHANNELS.....	62
8.5.4.	AVERAGE TIME OF OCCUPANCY .....	65
8.5.5.	OUTPUT POWER .....	69
8.5.6.	AVERAGE POWER.....	70
8.5.7.	CONDUCTED BANDEDGE AND SPURIOUS EMISSIONS.....	71
8.6.	LOW POWER ENHANCED DATA RATE DQPSK MODULATION.....	75
8.6.1.	OUTPUT POWER .....	75
8.6.2.	AVERAGE POWER.....	76
8.7.	LOW POWER ENHANCED DATA RATE 8PSK MODULATION .....	77
8.7.1.	20 dB AND 99% BANDWIDTH .....	77
8.7.2.	HOPPING FREQUENCY SEPARATION .....	80
8.7.3.	NUMBER OF HOPPING CHANNELS.....	81
8.7.4.	AVERAGE TIME OF OCCUPANCY .....	84
8.7.5.	OUTPUT POWER .....	88
8.7.6.	AVERAGE POWER.....	89
8.7.7.	CONDUCTED BANDEDGE AND SPURIOUS EMISSIONS.....	90
<b>9.</b>	<b>RADIATED TEST RESULTS.....</b>	<b>94</b>
9.1.	LIMITS AND PROCEDURE.....	94
9.2.	HIGH POWER BASIC DATA RATE GFSK MODULATION.....	95
9.2.1.	RESTRICTED BANDEDGE (LOW CHANNEL).....	95
9.2.2.	AUTHORIZED BANDEDGE (HIGH CHANNEL).....	97
9.2.3.	HARMONICS AND SPURIOUS EMISSIONS .....	99
9.3.	HIGH POWER ENHANCED DATA RATE 8PSK MODULATION .....	105
9.3.1.	RESTRICTED BANDEDGE (LOW CHANNEL).....	105
9.3.2.	AUTHORIZED BANDEDGE (HIGH CHANNEL).....	107
9.3.3.	HARMONICS AND SPURIOUS EMISSIONS .....	109
9.4.	LOW POWER BASIC DATA RATE GFSK MODULATION.....	115
9.4.1.	RESTRICTED BANDEDGE (LOW CHANNEL).....	115
9.4.2.	AUTHORIZED BANDEDGE (HIGH CHANNEL).....	117
9.4.3.	HARMONICS AND SPURIOUS EMISSIONS .....	119
9.5.	LOW POWER ENHANCED DATA RATE 8PSK MODULATION .....	125
9.5.1.	RESTRICTED BANDEDGE (LOW CHANNEL).....	125
9.5.2.	AUTHORIZED BANDEDGE (HIGH CHANNEL).....	127
9.5.3.	HARMONICS AND SPURIOUS EMISSIONS .....	129
9.6.	WORST-CASE CO-LOCATION.....	135
9.7.	WORST-CASE BELOW 1 GHz.....	137
9.8.	WORST-CASE ABOVE 18 GHz .....	139
<b>10.</b>	<b>AC POWER LINE CONDUCTED EMISSIONS .....</b>	<b>141</b>
10.1.	EUT POWERED BY AC/DC ADAPTER VIA USB CABLE.....	142

---

10.2. EUT POWERED BY HOST PC VIA USB CABLE..... 144

**11. SETUP PHOTOS ..... 146**

# 1. ATTESTATION OF TEST RESULTS

**COMPANY NAME:** APPLE  
1 INFINITE LOOP  
CUPERTINO, CA 95014, U.S.A.

**EUT DESCRIPTION:** TABLE DEVICE

**MODEL:** A1671, A1821

**SERIAL NUMBER:** DLXST016HPJQ (Conducted), DLXST00NHPJQ (Radiated)

**DATE TESTED:** NOVEMBER 23, 2016 – JANUARY 17, 2017

APPLICABLE STANDARDS	
STANDARD	TEST RESULTS
CFR 47 Part 15 Subpart C	Pass
INDUSTRY CANADA RSS-247 Issue 1	Pass
INDUSTRY CANADA RSS-GEN Issue 4	Pass

UL Verification Services Inc. tested the above equipment in accordance with the requirements set forth in the above standards. All indications of Pass/Fail in this report are opinions expressed by UL Verification Services Inc. based on interpretations and/or observations of test results. Measurement Uncertainties were not taken into account and are published for informational purposes only. The test results show that the equipment tested is capable of demonstrating compliance with the requirements as documented in this report.

**Note:** The results documented in this report apply only to the tested sample, under the conditions and modes of operation as described herein. This document may not be altered or revised in any way unless done so by UL Verification Services Inc. and all revisions are duly noted in the revisions section. Any alteration of this document not carried out by UL Verification Services Inc. will constitute fraud and shall nullify the document. This report must not be used by the client to claim product certification, approval, or endorsement by NVLAP, NIST, any agency of the Federal Government, or any agency of any government.

Approved & Released For  
UL Verification Services Inc. By:

Prepared By:

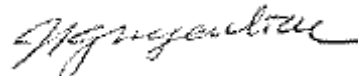
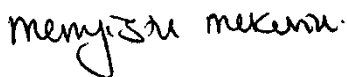

MENGISTU MEKURIA  
SENIOR ENGINEER  
UL VERIFICATION SERVICES INC.

LIEU NGUYEN  
TEST ENGINEER  
UL VERIFICATION SERVICES INC.

## 2. TEST METHODOLOGY

The tests documented in this report were performed in accordance with FCC CFR 47 Part 2, FCC CFR 47 Part 15, ANSI C63.10-2013, RSS-GEN Issue 4, and RSS-247 Issue 1.

## 3. FACILITIES AND ACCREDITATION

The test sites and measurement facilities used to collect data are located at 47173 and 47266 Benicia Street, Fremont, California, USA. Line conducted emissions are measured only at the 47173 address. The following table identifies which facilities were utilized for radiated emission measurements documented in this report. Specific facilities are also identified in the test results sections.

47173 Benicia Street	47266 Benicia Street
<input type="checkbox"/> Chamber A (IC:2324B-1)	<input checked="" type="checkbox"/> Chamber D (IC:2324B-4)
<input type="checkbox"/> Chamber B (IC:2324B-2)	<input checked="" type="checkbox"/> Chamber E (IC:2324B-5)
<input type="checkbox"/> Chamber C (IC:2324B-3)	<input checked="" type="checkbox"/> Chamber F (IC:2324B-6)
	<input type="checkbox"/> Chamber G (IC:2324B-7)
	<input type="checkbox"/> Chamber H (IC:2324B-8)

The above test sites and facilities are covered under FCC Test Firm Registration # 208313.

UL Verification Services Inc. is accredited by NVLAP, Laboratory Code 200065-0. The full scope of accreditation can be viewed at <http://ts.nist.gov/standards/scopes/2000650.htm>.

## 4. CALIBRATION AND UNCERTAINTY

### 4.1. MEASURING INSTRUMENT CALIBRATION

The measuring equipment utilized to perform the tests documented in this report has been calibrated in accordance with the manufacturer's recommendations, and is traceable to recognized national standards.

### 4.2. SAMPLE CALCULATION

Where relevant, the following sample calculation is provided:

$$\begin{aligned} \text{Field Strength (dBuV/m)} &= \text{Measured Voltage (dBuV)} + \text{Antenna Factor (dB/m)} + \\ &\text{Cable Loss (dB)} - \text{Preamp Gain (dB)} \\ 36.5 \text{ dBuV} + 18.7 \text{ dB/m} + 0.6 \text{ dB} - 26.9 \text{ dB} &= 28.9 \text{ dBuV/m} \end{aligned}$$

### 4.3. MEASUREMENT UNCERTAINTY

Where relevant, the following measurement uncertainty levels have been estimated for tests performed on the apparatus:

Parameter	Uncertainty
Worst Case Conducted Disturbance, 9KHz to 0.15 MHz	3.84 dB
Worst Case Conducted Disturbance, 0.15 to 30 MHz	3.65 dB
Worst Case Radiated Disturbance, 9KHz to 30 MHz	3.15 dB
Worst Case Radiated Disturbance, 30 to 1000 MHz	5.36 dB
Worst Case Radiated Disturbance, 1000 to 18000 MHz	4.32 dB
Worst Case Radiated Disturbance, 18000 to 26000 MHz	4.45 dB
Worst Case Radiated Disturbance, 26000 to 40000 MHz	5.24 dB

Uncertainty figures are valid to a confidence level of 95%.

## 5. EQUIPMENT UNDER TEST

### 5.1. DESCRIPTION OF EUT

The EUT, model number A1671, A1821 is a tablet with multimedia functions (music, application support, and video), Cellular GSM/GPRS/EGPRS/CDMA2000 1xRTT/1x Advanced/EVDO Rev.A/WCDMA /HSPA+/DC- HSDPA/LTE FDD & Carrier Aggregation/TDD/TD-SCDMA radio, IEEE 802.11a/b/g/n/ac radio, and Bluetooth radio. The rechargeable battery is not user accessible.

### 5.1. DESCRIPTION OF MODELS DIFFERENCES

Both Model A1671 and A1821 have identical PCB layout, design and functionality, except that A1671 supports second electronic-UICC based SIM or “soft SIM” (called eSIM) beside the regular UICC based SIM and A1821 will come with eSIM removed. RF and electromagnetic characteristic are independent of the eSIM element. Both Models have exactly same technology and band support. Model A1671 is used for EMC/RSE Testing and that data will be used for both Models

### 5.2. MAXIMUM OUTPUT POWER

The transmitter has a maximum peak conducted output power as follows:

Frequency Range (MHz)	Mode	Output Power (dBm)	Output Power (mW)
2402 - 2480	Basic GFSK	17.27	53.33
2402 - 2480	DQPSK	17.70	58.88
2402 - 2480	Enhanced 8PSK	17.83	60.67

### 5.3. DESCRIPTION OF AVAILABLE ANTENNAS

Frequency Band (GHz)	Antenna Gain (dBi)
2.4	-0.48

### 5.4. SOFTWARE AND FIRMWARE

The firmware installed in the EUT during testing was 14E232.

## 5.5. WORST-CASE CONFIGURATION AND MODE

For below 1G, 18-26GHz radiated emission, and power line conducted emissions were performed with the EUT set to transmit at the channel with highest output power as worst-case scenario.

The fundamental of the EUT was investigated in three orthogonal orientations X/Y/Z, it was determined that Y (Landscape) orientation was worst-case orientation. Therefore, all final radiated testing was performed with the EUT in Y orientation.

Worst-case data rates were:

GFSK mode: DH5  
8PSK mode: 3-DH5

DQPSK mode has been verified to have the lowest power.

There are two vendors of the WiFi/Bluetooth radio modules: variant 1 and variant 2. The WiFi/Bluetooth radio modules have the same mechanical outline (e.g., the same package dimension and pin-out layout), use the same on-board antenna matching circuit, have an identical antenna structure, and are built and tested to conform to the same specifications and to operate within the same tolerances.

Baseline testing was performed on the two variants to determine the worst case on all conducted power and radiated emissions.

## 5.6. DESCRIPTION OF TEST SETUP

### SUPPORT EQUIPMENT

Support Equipment List				
Description	Manufacturer	Model	Serial Number	FCC ID
Laptop	Apple	A1286	7313700NAGW	N/A
Laptop AC/DC adapter	Apple	A1343	C062172045DDJ94A6	N/A
Earphone	Apple	NA	NA	N/A
EUT AC/DC adapter	Apple	A1357	W010A051	N/A

### I/O CABLES (CONDUCTED TEST)

I/O Cable List						
Cable No	Port	# of identical ports	Connector Type	Cable Type	Cable Length (m)	Remarks
1	Antenna	1	SMA	Un-Shielded	0.2	To spectrum Analyzer
2	USB	1	USB	Shielded	1	N/A
3	AC	1	AC	Un-shielded	2	N/A

### I/O CABLES (RADIATED ABOVE 1 GHZ)

I/O Cable List						
Cable No	Port	# of identical ports	Connector Type	Cable Type	Cable Length (m)	Remarks
None Used						

### I/O CABLES (RADIATED BELOW 1 GHZ AND AC LINE CONDUCTED: AC/DC ADAPTER CONFIGURATION)

I/O Cable List						
Cable No	Port	# of identical	Connector Type	Cable Type	Cable Length (m)	Remarks
1	Earphone Jack	1	3.5mm Audio	Shielded	0.9	N/A
2	USB	1	USB	shielded	1	N/A

### I/O CABLES (AC LINE CONDUCTED: LAPTOP CONFIGUARTION)

I/O Cable List						
Cable No	Port	# of identical	Connector Type	Cable Type	Cable Length (m)	Remarks
1	Earphone Jack	1	3.5mm Audio	Shielded	0.9	N/A
2	USB	1	USB	Shielded	1	N/A
3	AC	1	AC	Un-shielded	2	N/A

**TEST SETUP - CONDUCTED TESTS**

The EUT was connected to a host Laptop via USB cable adapter and spectrum analyzer to antenna port. Test software exercised the EUT.

**SETUP DIAGRAM**

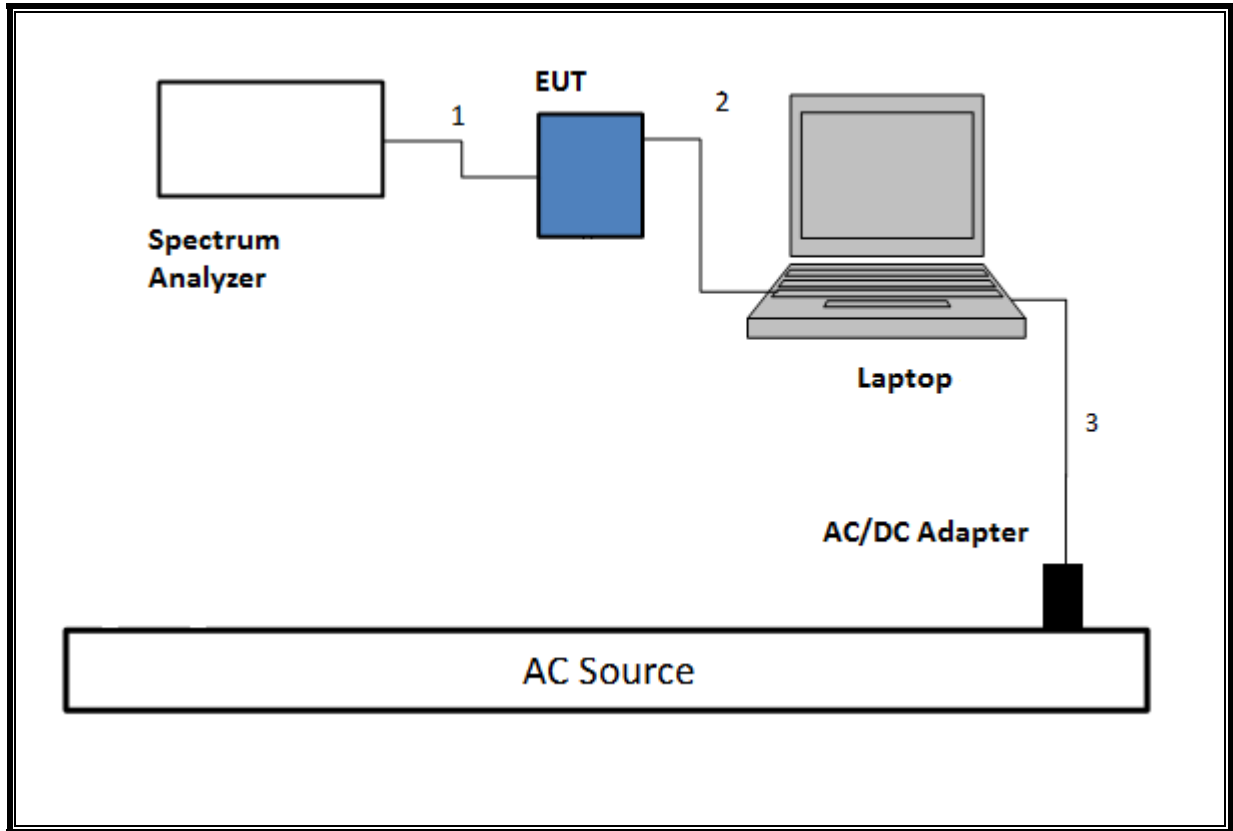

**TEST SETUP- RADIATED-ABOVE 1 GHZ**

The EUT was powered by battery. Test software exercised the EUT.

**SETUP DIAGRAM**

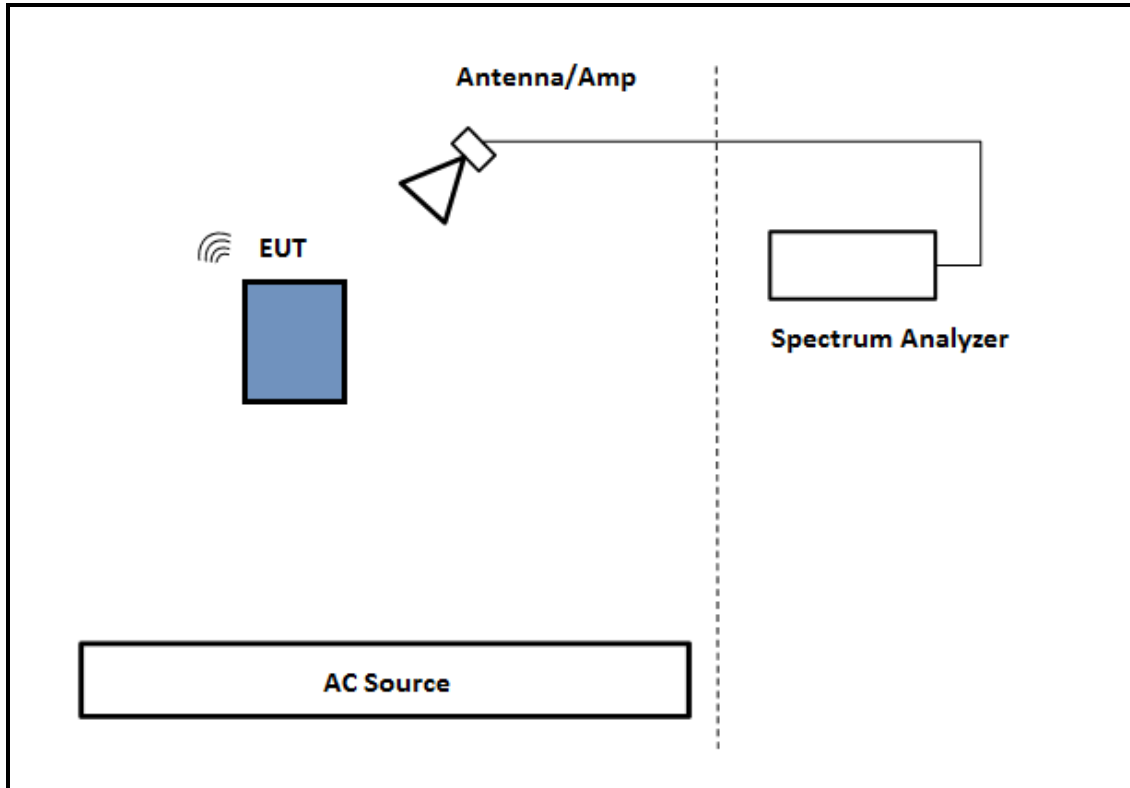

**TEST SETUP- BELOW 1GHz**

The EUT was powered by AC/DC adapter and connected with earphone. Test software exercised the EUT.

**SETUP DIAGRAM**

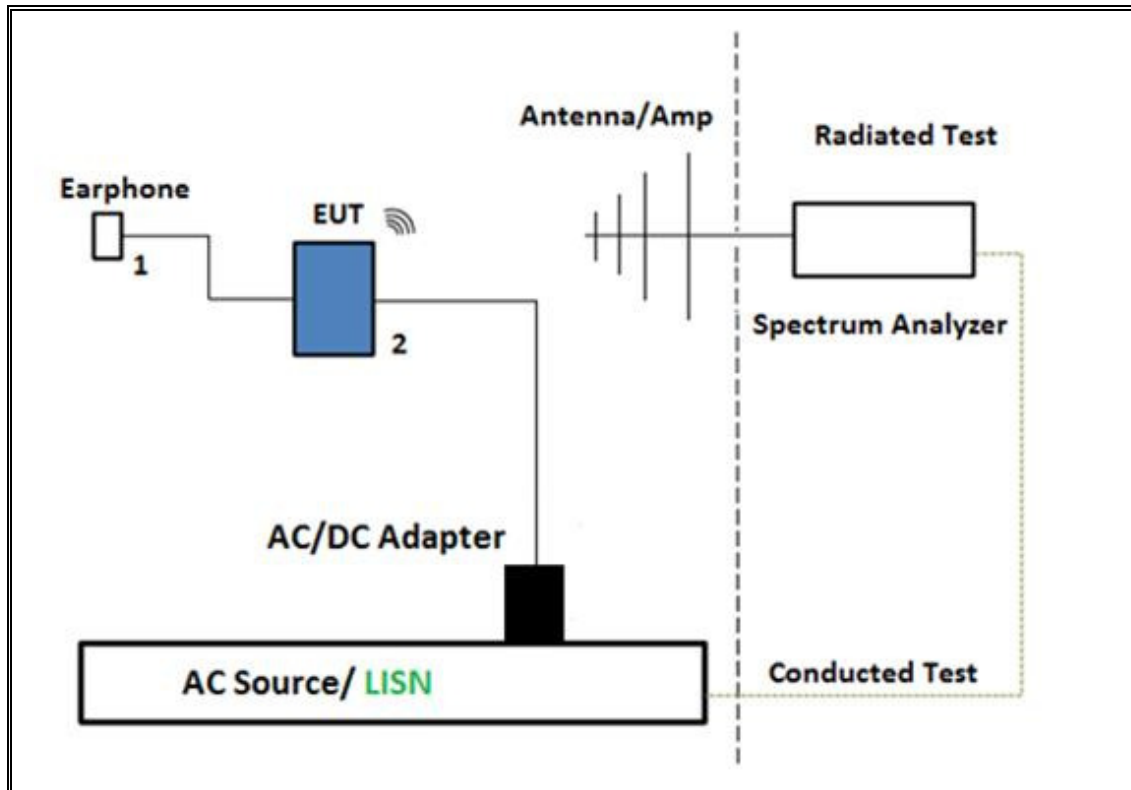

**TEST SETUP- AC LINE CONDUCTED: AC/DC ADAPTER CONFIGURATION**

The EUT was tested with earphone connected and powered by AC/DC adapter via USB cable. Test software exercised the EUT.

**SETUP DIAGRAM**

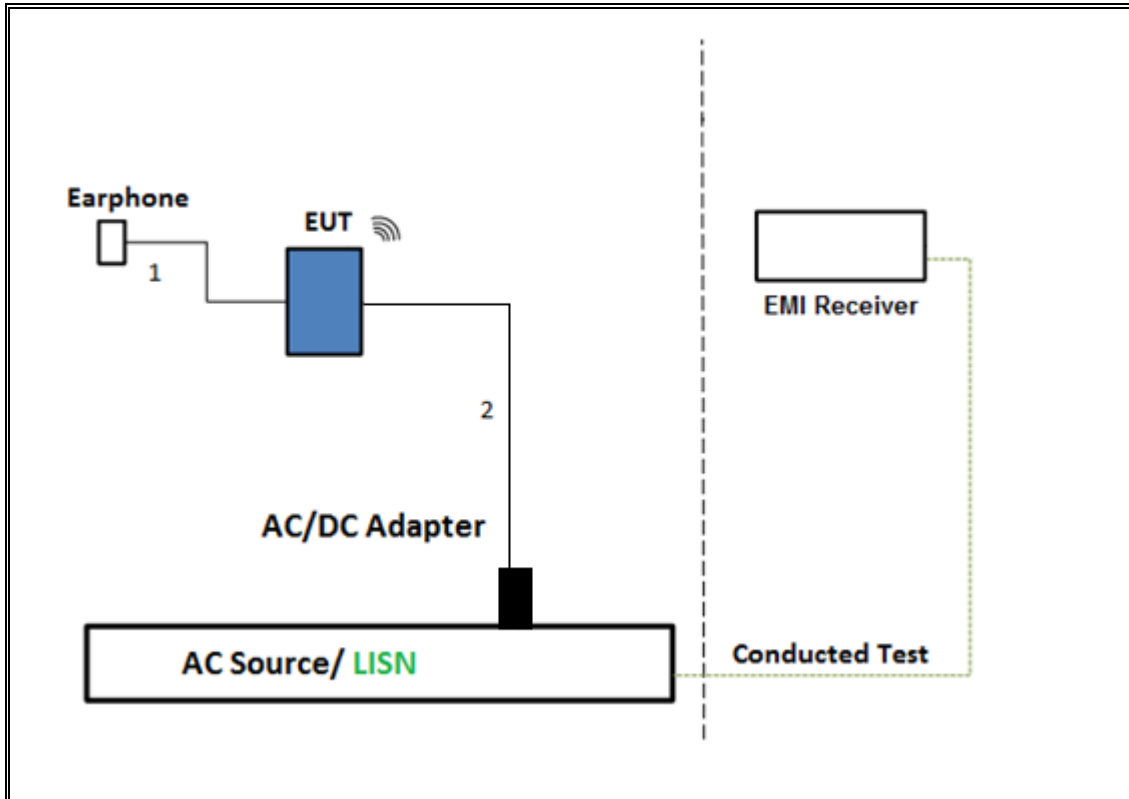

**TEST SETUP- AC LINE CONDUCTED: LAPTOP CONFIGURATION**

The EUT was tested with earphone connected and powered by host PC via USB cable. Test software exercised the EUT.

**SETUP DIAGRAM**

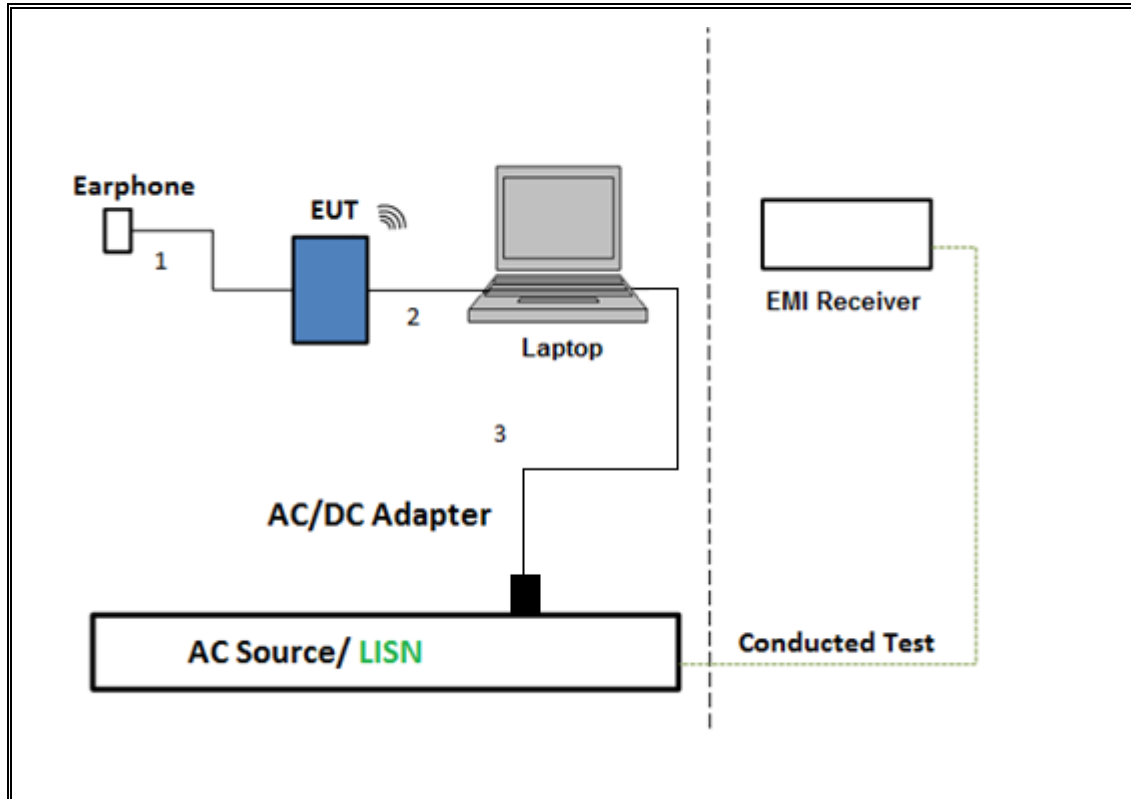

## 6. TEST AND MEASUREMENT EQUIPMENT

The following test and measurement equipment was utilized for the tests documented in this report:

TEST EQUIPMENT LIST				
Description	Manufacturer	Model	Asset	Cal Due
Amplifier, 1 - 18GHz	MITEQ	AFS42-00101800-25-S-42	T491	05/31/2017
Antenna, Active Loop 9KHz to 30MHz	ETS-Lindgren	6502	T757	05/31/2017
Antenna, Broadband Hybrid, 30MHz to 2000MHz	Sunol Sciences Corp.	JB3	T900	05/03/2017
Antenna, Double Ridge Guide Horn Antenna 700MHz to 18GHz	A.H. SYSTEMS, INC.	SAS-571	T962	09/15/2017
Antenna, Double Ridge Guide Horn Antenna 700MHz to 18GHz	A.H. SYSTEMS, INC.	SAS-571	T963	09/29/2017
Antenna, Horn 1-18GHz	ETS-Lindgren	3117	T344	02/22/2017
Antenna, Horn 1-18GHz	ETS-Lindgren	3117	T712	01/12/2017
Filter, HPF 3.0GHz	MICRO-TRONICS	HPM17543	T898	05/31/2017
Power Meter, P-series single channel	Keysight	N1912A	T1245	05/03/2017
Power Sensor, P - series, 50MHz to 18GHz, Wideband	Keysight	N1921A	T750	10/17/2017
Power Sensor, P - series, 50MHz to 18GHz, Wideband	Keysight	N1921A	T1226	05/18/2017
Spectrum Analyzer, PXA, 3Hz to 44GHz	Keysight	N9030A	T1466	03/09/2017
Antenna, Horn 18 to 26.5GHz	ARA	MWH-1826/B	T447	06/16/2017
Amplifier, 1 to 26.5GHz, 23.5dB Gain minimum	Keysight	8449B	T402	7/5/2017
AC Line Conducted				
*EMI Test Receiver 9KHz-7GHz	Rohde & Schwarz	ESCI7	T1436	12/19/2016
LISN for Conducted Emissions CISPR-16	Fischer	50/250-25-2-01	T1310	06/08/2017
Power Cable, Line Conducted Emissions	UL	PG1	T861	9/1/2017
UL AUTOMATION SOFTWARE				
Radiated Software	UL	UL EMC	Ver 9.5, April 26, 2016	
Conducted Software	UL	UL EMC	Ver 5.4, October 13, 2016	
AC Line Conducted Software	UL	UL EMC	Ver 9.5, May 26, 2015	

NOTE: \*testing is completed before equipment calibration expiration date.

## 7. MEASUREMENT METHODS

On Time and Duty Cycle: ANSI C63.10-2013 Section 11.6

Occupied BW (99%): ANSI C63.10-2013 Section 6.9.3

Carrier Frequency Separation: ANSI C63.10-2013 Section 7.8.2

Number of Hopping Frequencies: ANSI C63.10-2013 Section 7.8.3

Time of Occupancy (Dwell Time): ANSI C63.10-2013 Section 7.8.4

Peak Output Power: ANSI C63.10-2013 Section 7.8.5

Conducted Spurious Emissions: ANSI C63.10-2013 Section 7.8.8

Conducted Band-Edge: ANSI C63.10-2013 Section 6.10.4

Radiated Spurious Emissions 30-1000MHz: ANSI C63.10-2013 Section 6.3 and 6.5

Radiated Spurious Emissions above 1GHz: ANSI C63.10-2013 Section 6.3 and 6.6

Radiated Band-edge: ANSI C63.10-2013 Section 6.10.5

AC Power-line conducted emissions: ANSI C63.10-2013, Section 6.2.

## 8. ANTENNA PORT TEST RESULTS

### 8.1. ON TIME AND DUTY CYCLE

#### LIMITS

None; for reporting purposes only.

#### PROCEDURE

ANSI C63.10, Section 11.6 : Zero-Span Spectrum Analyzer Method.

#### ON TIME AND DUTY CYCLE RESULTS

Mode	ON Time B (msec)	Period (msec)	Duty Cycle x (linear)	Duty Cycle (%)	Duty Cycle Correction Factor (dB)	1/B Minimum VBW (kHz)
GFSK HIGH POWER	1.000	1.000	1.000	100.00%	0.00	0.010
8PSK HIGH POWER	1.000	1.000	1.000	100.00%	0.00	0.010
GFSK LOW POWER	1.000	1.000	1.000	100.00%	0.00	0.010
8PSK LOW POWER	1.000	1.000	1.000	100.00%	0.00	0.010

**DUTY CYCLE PLOTS**

**8.1.1. HIGH POWER MODE**

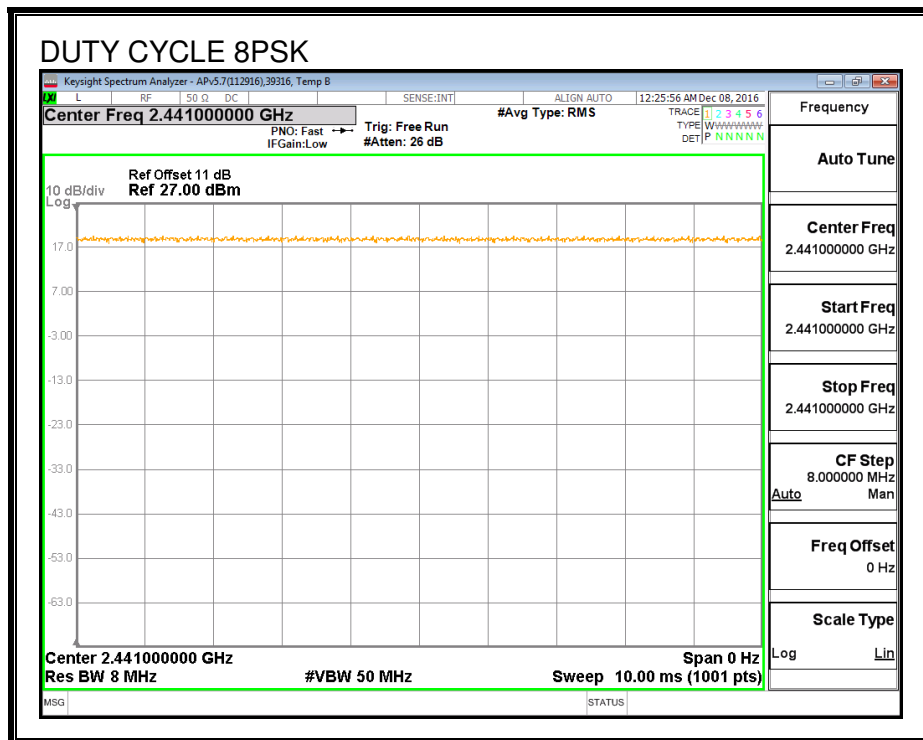
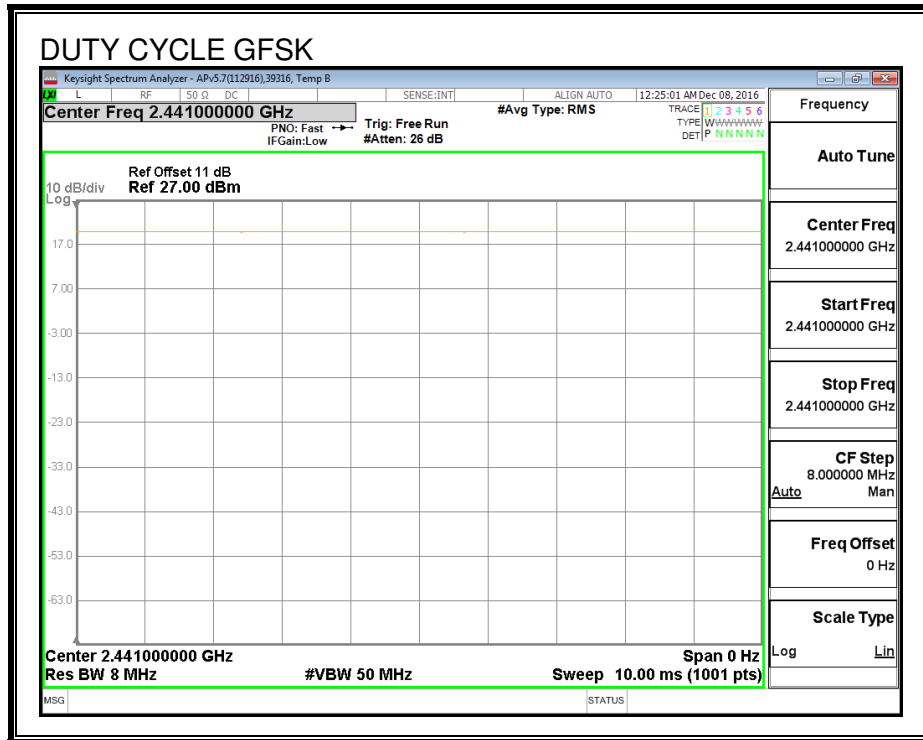

### 8.1.2. LOW POWER MODE

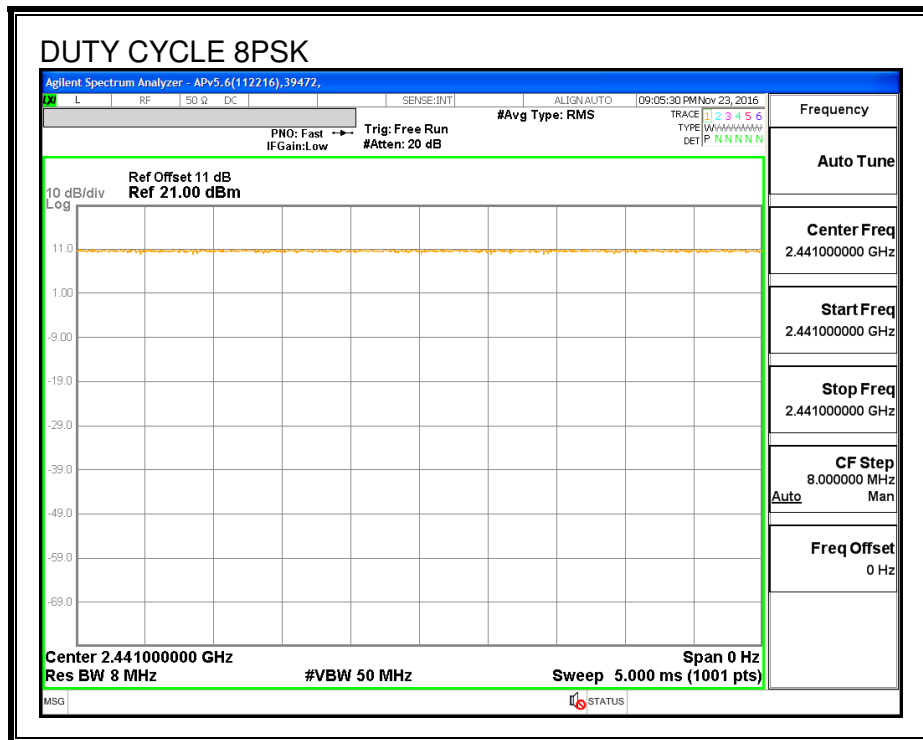
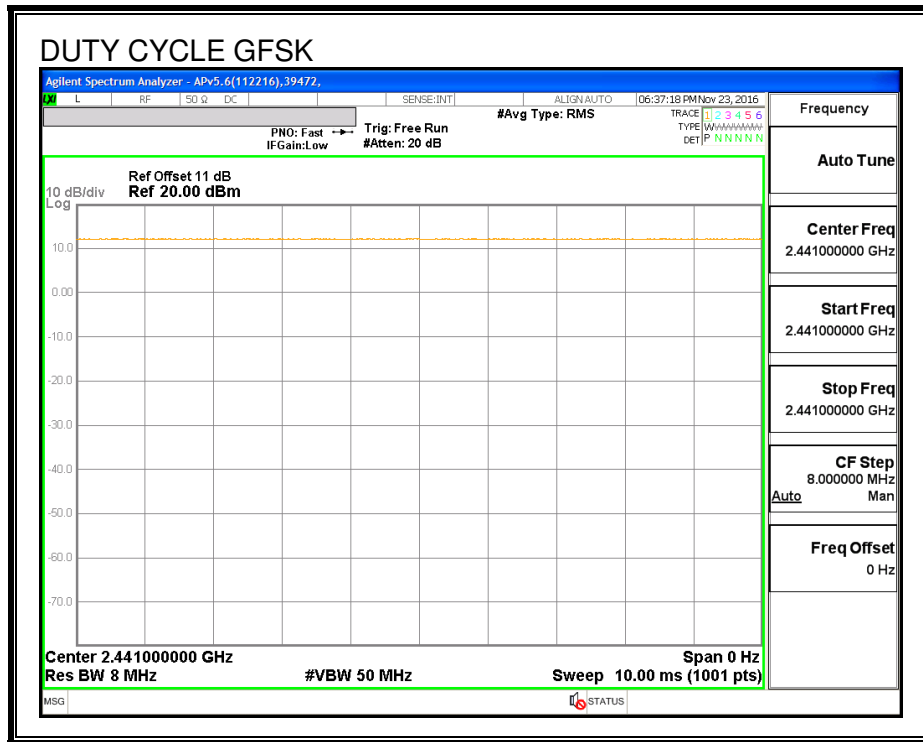

---

## 8.2. HIGH POWER BASIC DATA RATE GFSK MODULATION

### 8.2.1. 20 dB AND 99% BANDWIDTH

#### LIMITS

None; for reporting purposes only.

#### TEST PROCEDURE

The transmitter output is connected to a spectrum analyzer. The RBW is set to  $\geq 1\%$  of the 20 dB bandwidth. The VBW is set to  $\geq$  RBW. The sweep time is coupled

#### RESULTS

Channel	Frequency (MHz)	20 dB Bandwidth (KHz)	99% Bandwidth (KHz)
Low	2402	892.2	859.89
Middle	2441	862.3	864.37
High	2480	858.7	860.96

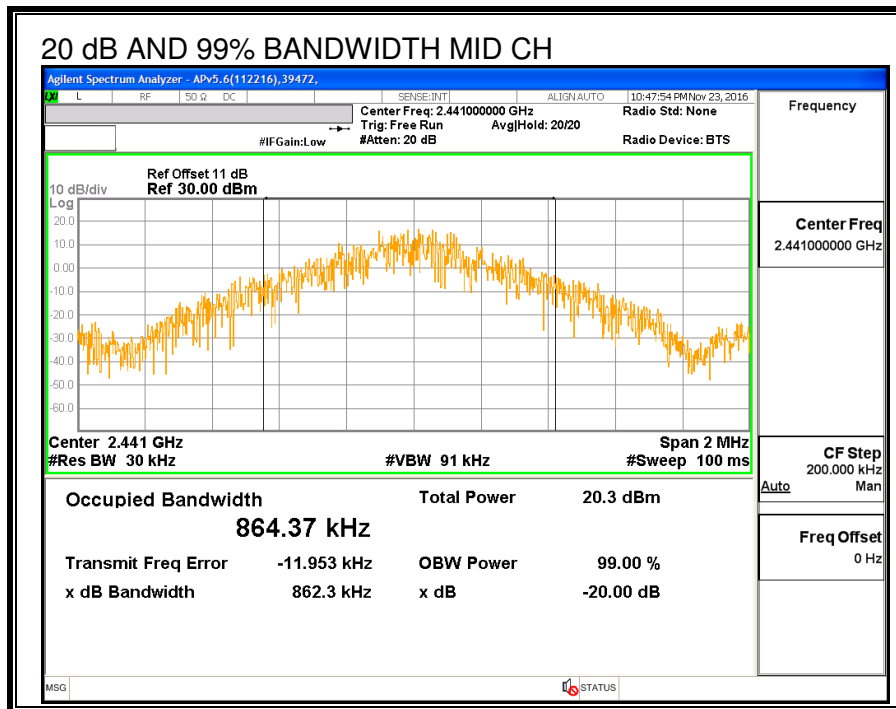
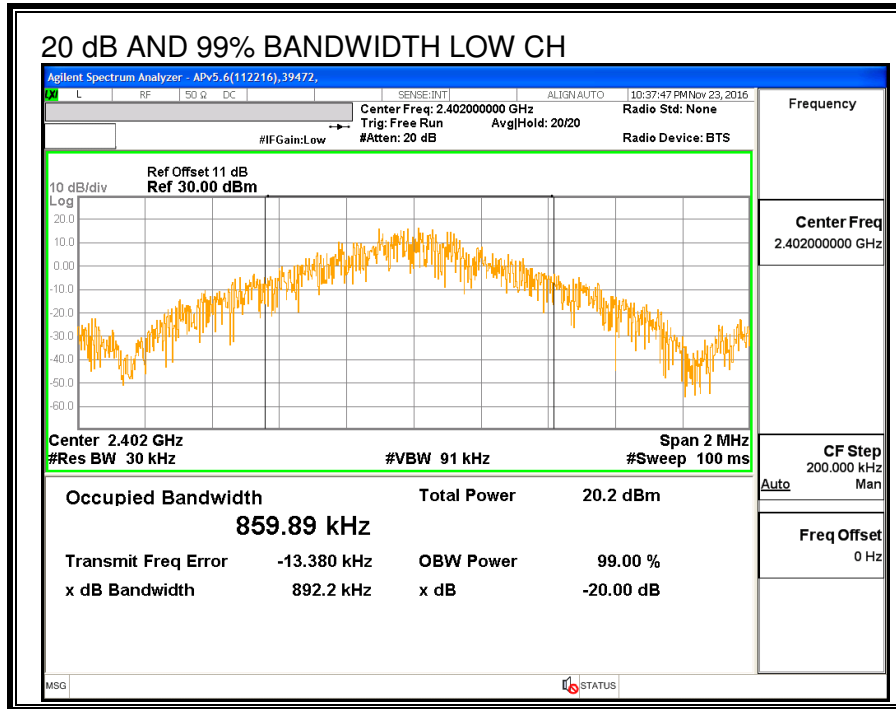

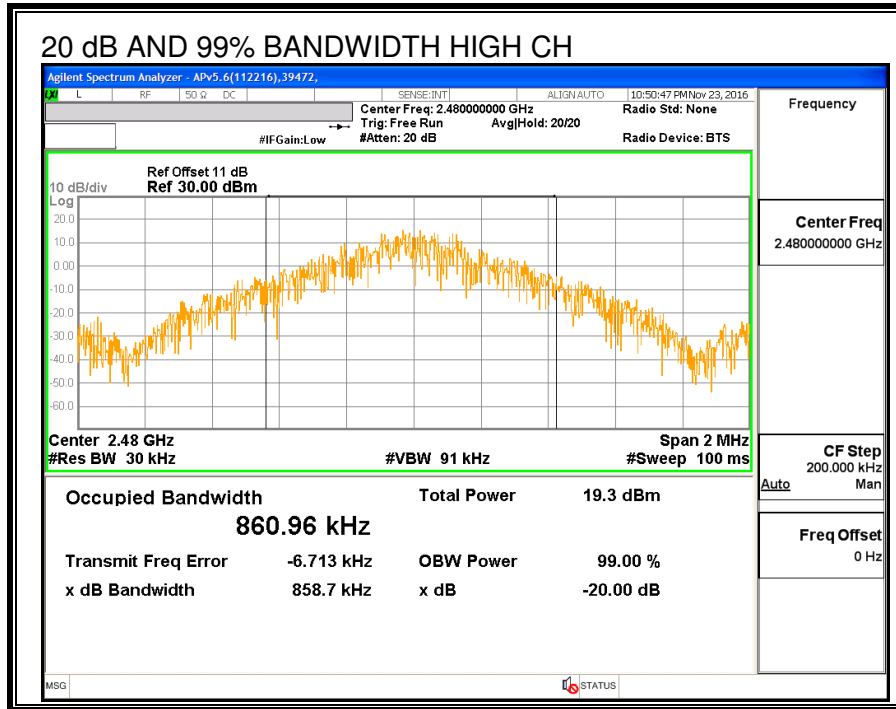

## 8.2.2. HOPPING FREQUENCY SEPARATION

### LIMITS

FCC §15.247 (a) (1)

IC RSS-247 (5.1) (2)

Frequency hopping systems shall have hopping channel carrier frequencies separated by a minimum of 25 kHz or the 20 dB bandwidth of the hopping channel, whichever is greater.

Alternatively, frequency hopping systems operating in the 2400-2483.5 MHz band may have hopping channel carrier frequencies that are separated by 25 kHz or two-thirds of the 20 dB bandwidth of the hopping channel, whichever is greater, provided the systems operate with an output power no greater than 125 mW.

### TEST PROCEDURE

The transmitter output is connected to a spectrum analyzer. The RBW is set to 300 kHz and the VBW is set to 910 kHz. The sweep time is coupled.

### RESULTS

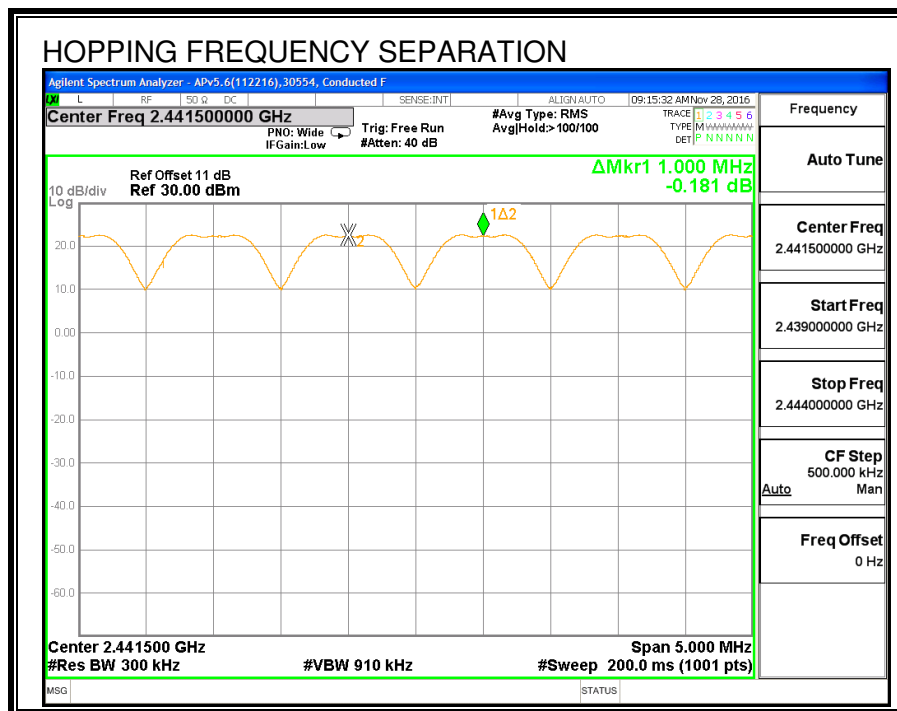

### 8.2.3. NUMBER OF HOPPING CHANNELS

#### LIMITS

FCC §15.247 (a) (1) (iii)

IC RSS-247 (5.1) (4)

Frequency hopping systems in the 2400 – 2483.5 MHz band shall use at least 15 non-overlapping channels.

#### TEST PROCEDURE

The transmitter output is connected to a spectrum analyzer. The span is set to cover the entire authorized band, in either a single sweep or in multiple contiguous sweeps. The RBW is set to a maximum of 1 % of the span. The analyzer is set to Max Hold.

#### RESULTS

Normal Mode: 79 Channels observed.

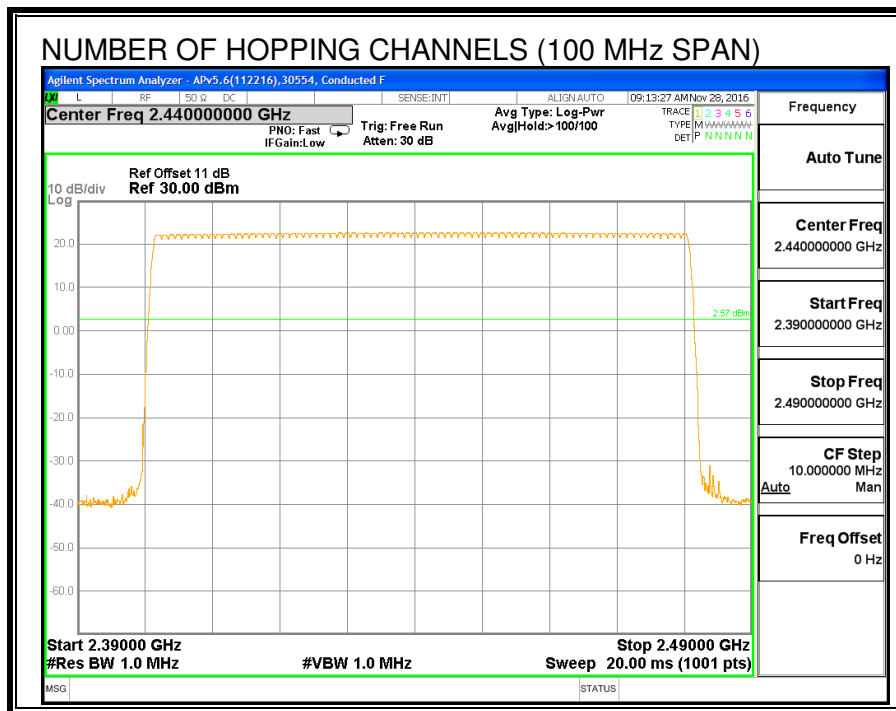

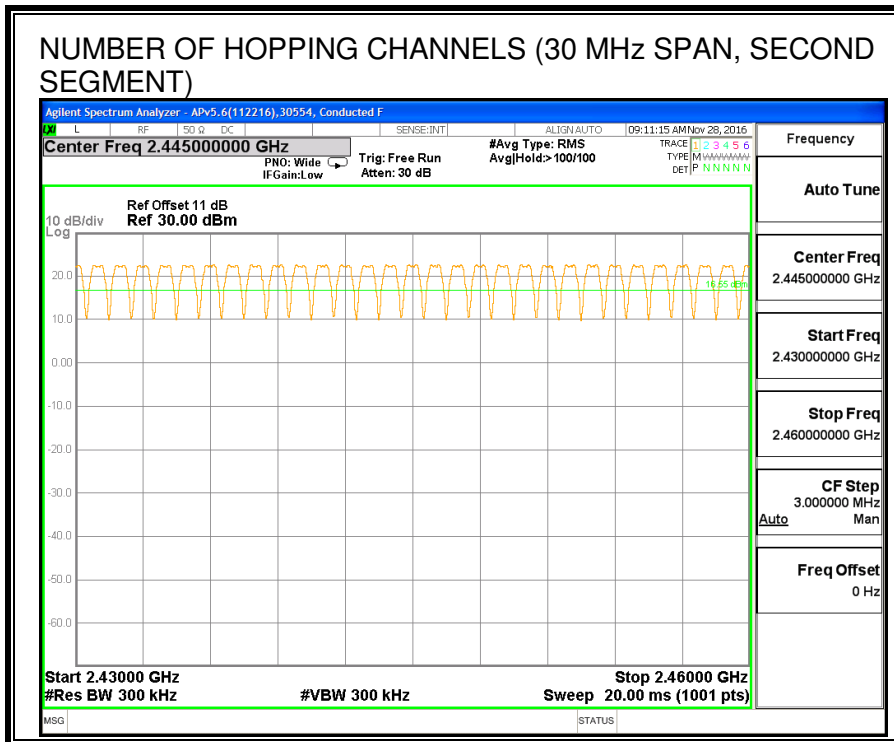
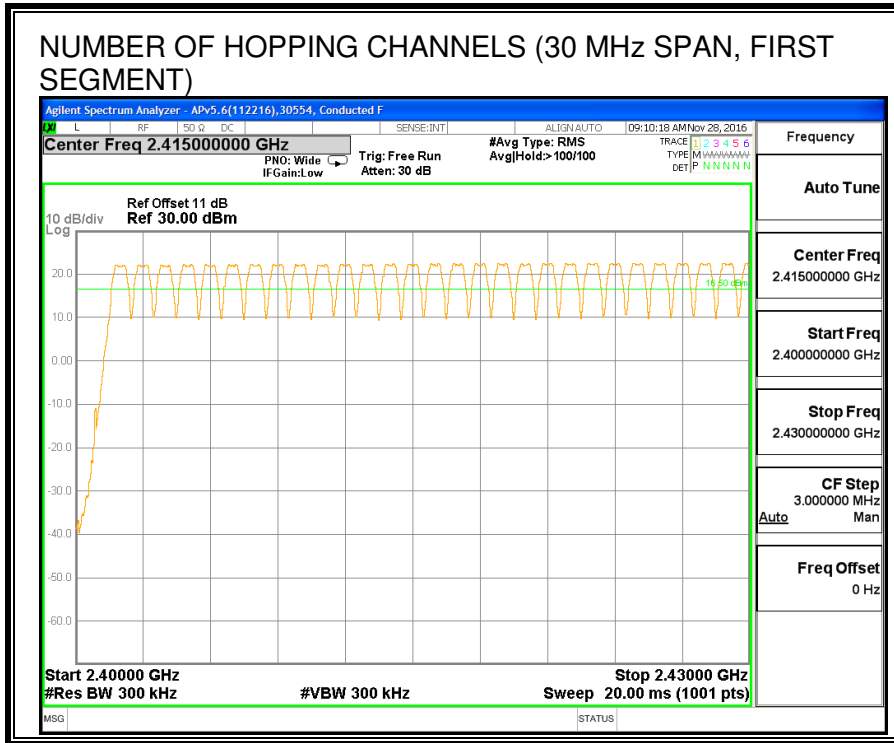

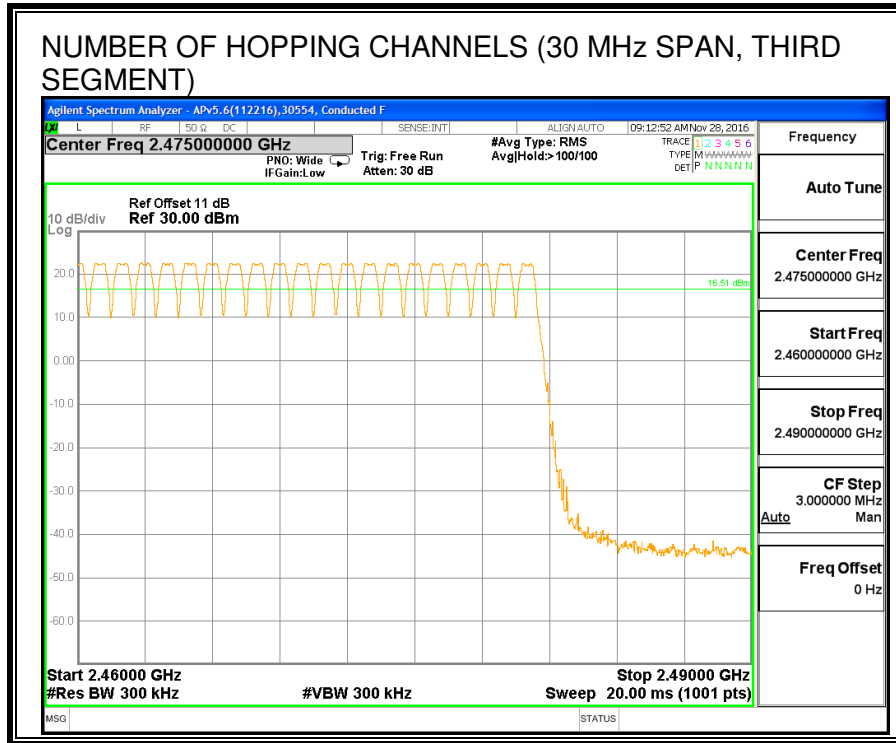

**8.2.4. AVERAGE TIME OF OCCUPANCY**

**LIMITS**

FCC §15.247 (a) (1) (iii)

IC RSS-247 (5.1) (4)

The average time of occupancy on any channel shall not be greater than 0.4 seconds within a period of 0.4 seconds multiplied by the number of hopping channels employed.

**TEST PROCEDURE**

The transmitter output is connected to a spectrum analyzer. The span is set to 0 Hz, centered on a single, selected hopping channel. The width of a single pulse is measured in a fast scan. The number of pulses is measured in a 3.16 second scan, to enable resolution of each occurrence.

The average time of occupancy in the specified 31.6 second period (79 channels \* 0.4 s) is equal to  $10 * (\# \text{ of pulses in } 3.16 \text{ s}) * \text{ pulse width}$ .

For AFH mode, the average time of occupancy in the specified 8 second period (20 channels \* 0.4 seconds) is equal to  $10 * (\# \text{ of pulses in } 0.8 \text{ s}) * \text{ pulse width}$ .

**RESULTS**

DH Packet	Pulse Width (msec)	Number of Pulses in 3.16 seconds	Average Time of Occupancy (sec)	Limit (sec)	Margin (sec)
<b>GFSK Normal Mode</b>					
DH1	0.394	31	0.122	0.4	-0.278
DH3	1.648	15	0.247	0.4	-0.153
DH5	2.896	10	0.290	0.4	-0.110
DH Packet	Pulse Width (msec)	Number of Pulses in 0.8 seconds	Average Time of Occupancy (sec)	Limit (sec)	Margin (sec)
<b>GFSK AFH Mode</b>					
DH1	0.394	7.75	0.031	0.4	-0.369
DH3	1.648	3.75	0.062	0.4	-0.338
DH5	2.896	2.5	0.072	0.4	-0.328

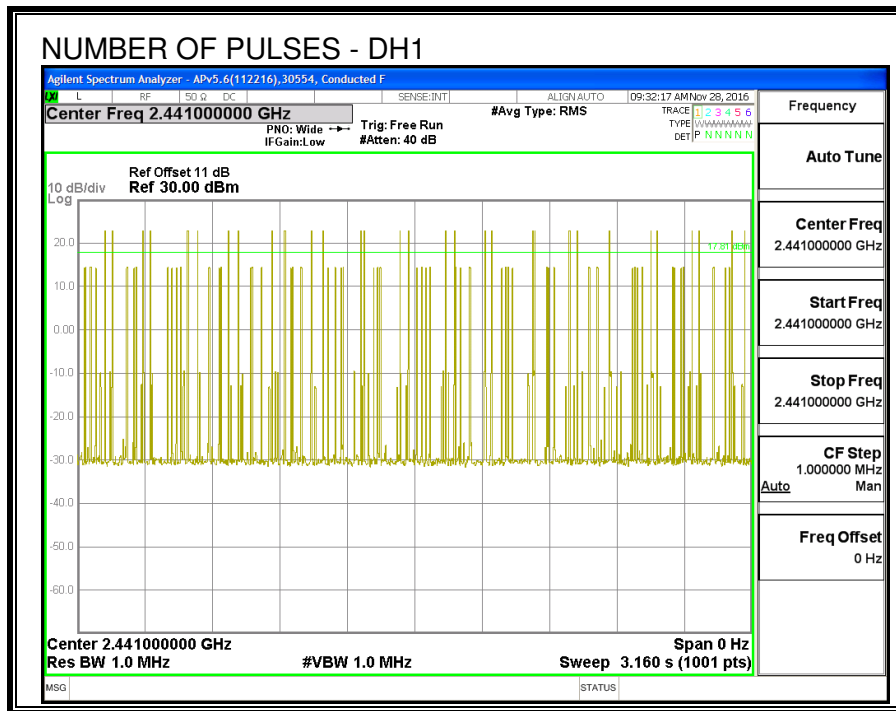
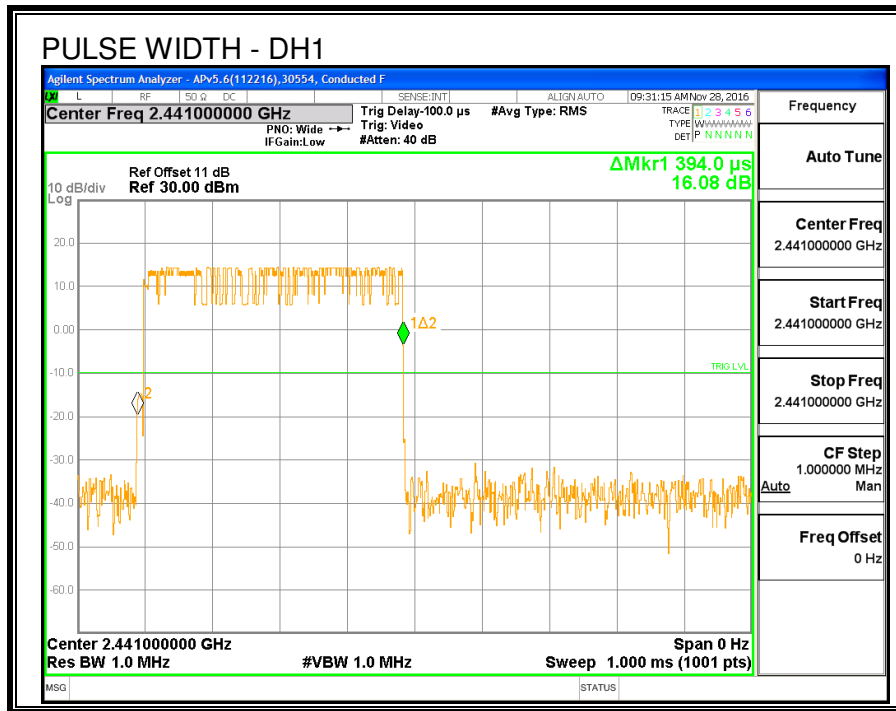

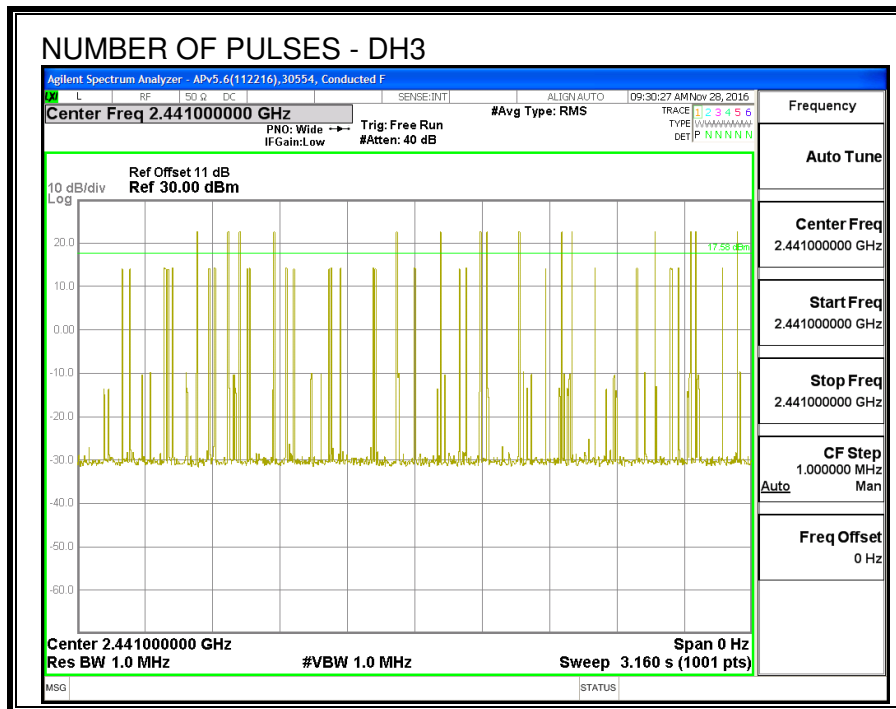
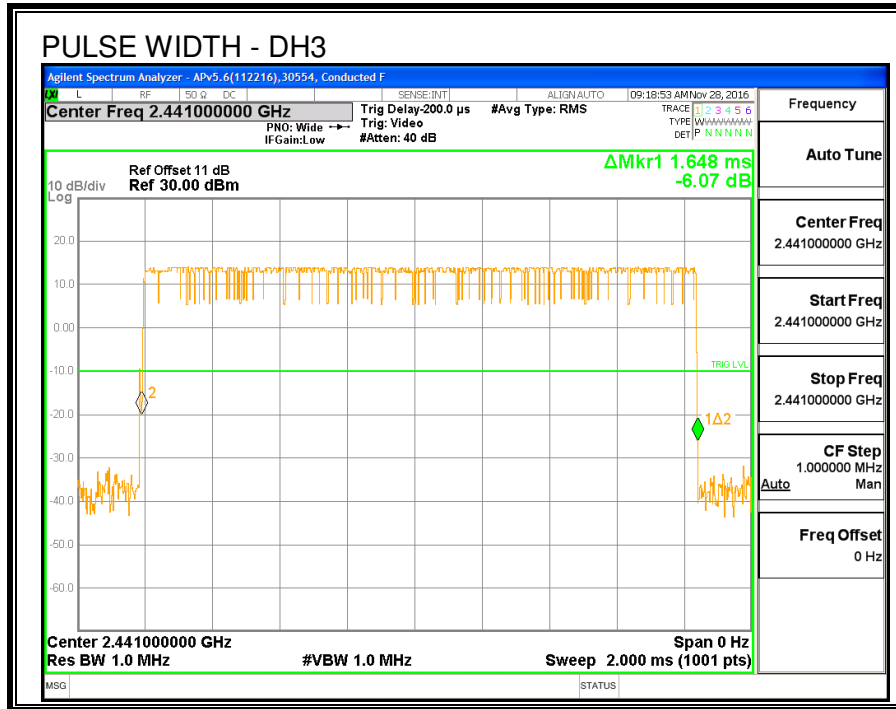

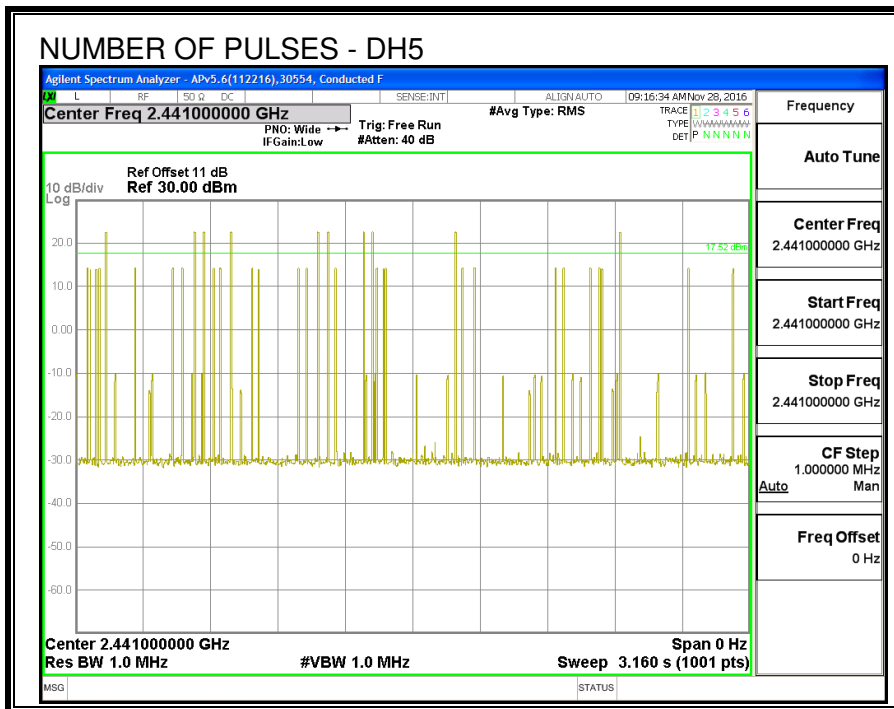
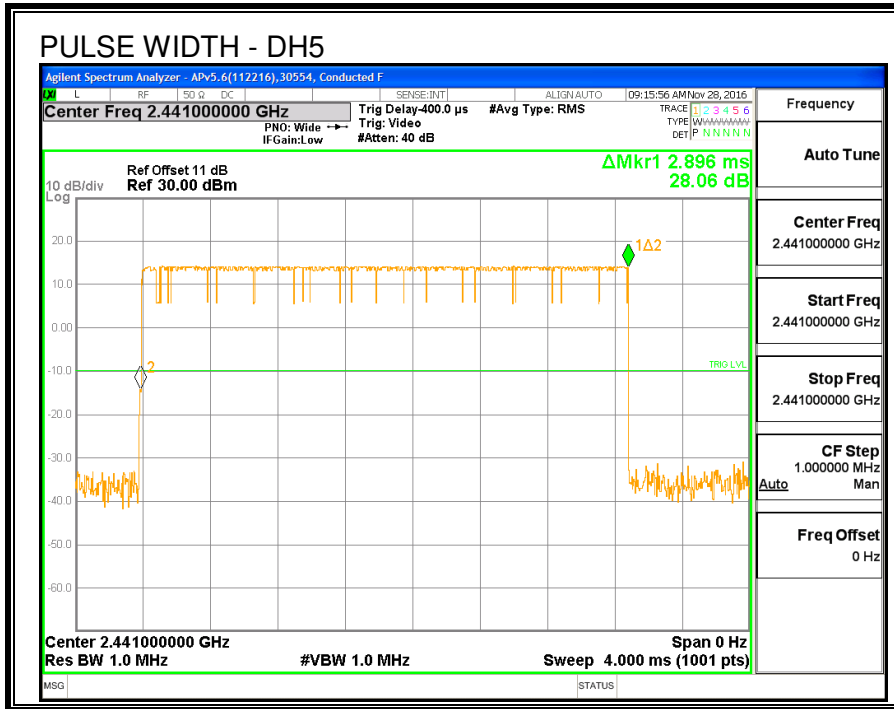

### 8.2.5. OUTPUT POWER

<b>ID:</b>	43578	<b>Date:</b>	1/19/17
------------	-------	--------------	---------

#### LIMITS

§15.247 (b) (1)

RSS-247 (5.4) (2)

The maximum antenna gain is less than 6 dBi, therefore the limit is 30 dBm.

#### TEST PROCEDURE

The transmitter output is connected to a wideband peak and average power meter.

#### RESULTS

Channel	Frequency (MHz)	Output Power (dBm)	Limit (dBm)	Margin (dB)
Low	2402	17.27	21	-3.73
Middle	2441	17.15	21	-3.85
High	2480	16.87	21	-4.13

---

### 8.2.6. AVERAGE POWER

<b>ID:</b>	43578	<b>Date:</b>	1/19/17
------------	-------	--------------	---------

#### LIMITS

None; for reporting purposes only.

#### TEST PROCEDURE

The transmitter output is connected to a power meter.

#### RESULTS

The cable assembly insertion loss of 11 dB (including 10 dB pad and 1 dB cable) was entered as an offset in the power meter to allow for direct reading of power.

Channel	Frequency (MHz)	Average Power (dBm)
Low	2402	16.98
Middle	2441	16.88
High	2480	16.52

### 8.2.7. CONDUCTED BANDEDGE AND SPURIOUS EMISSIONS

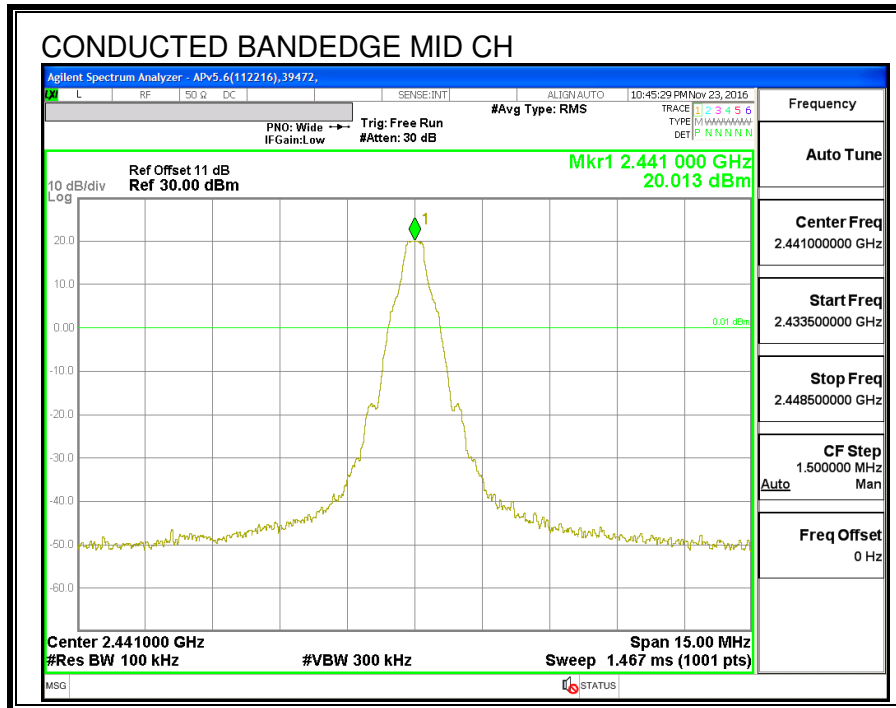
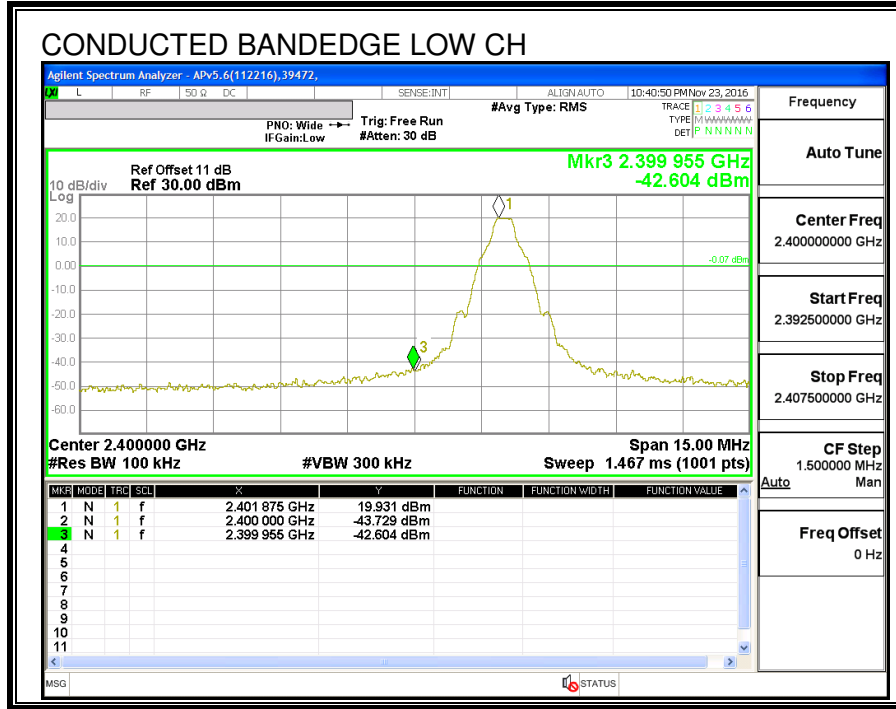

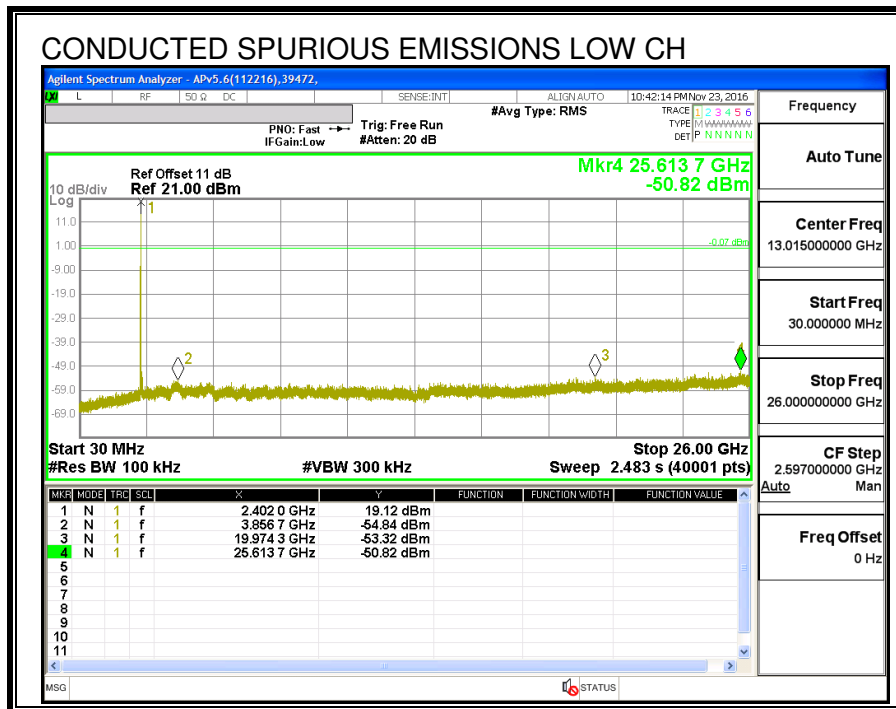
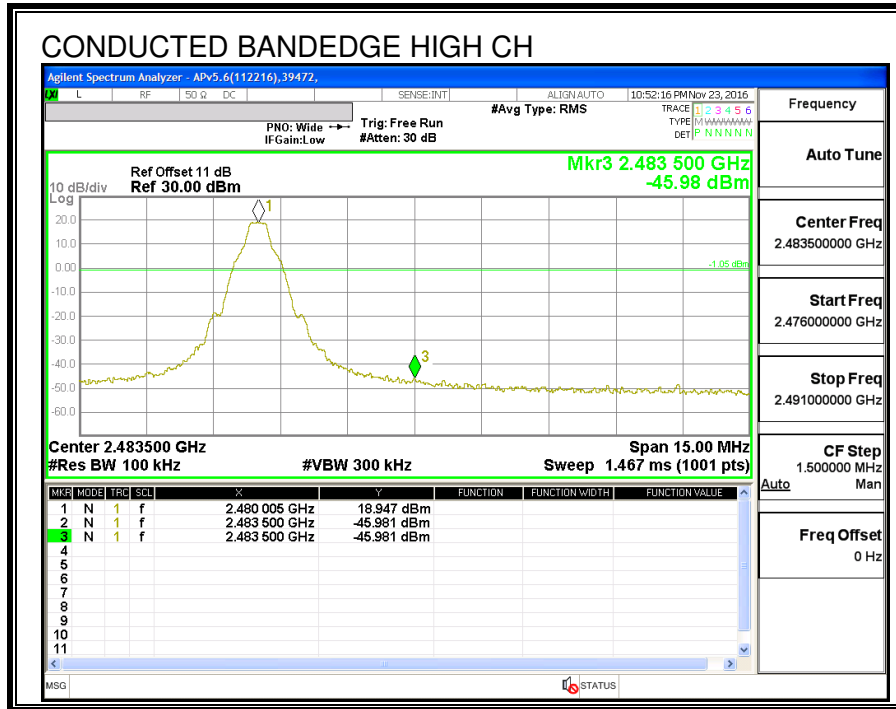

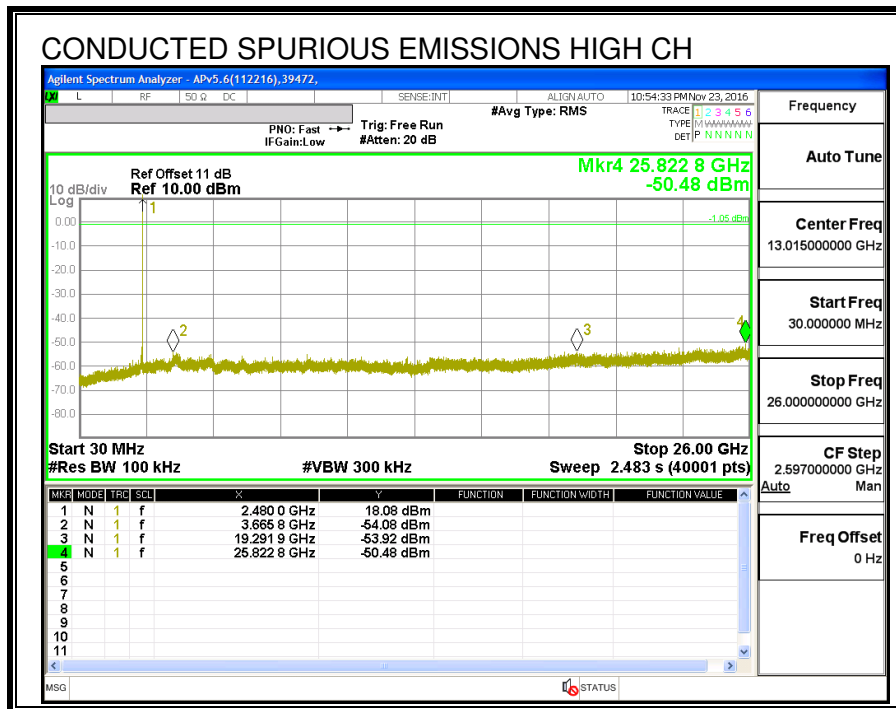
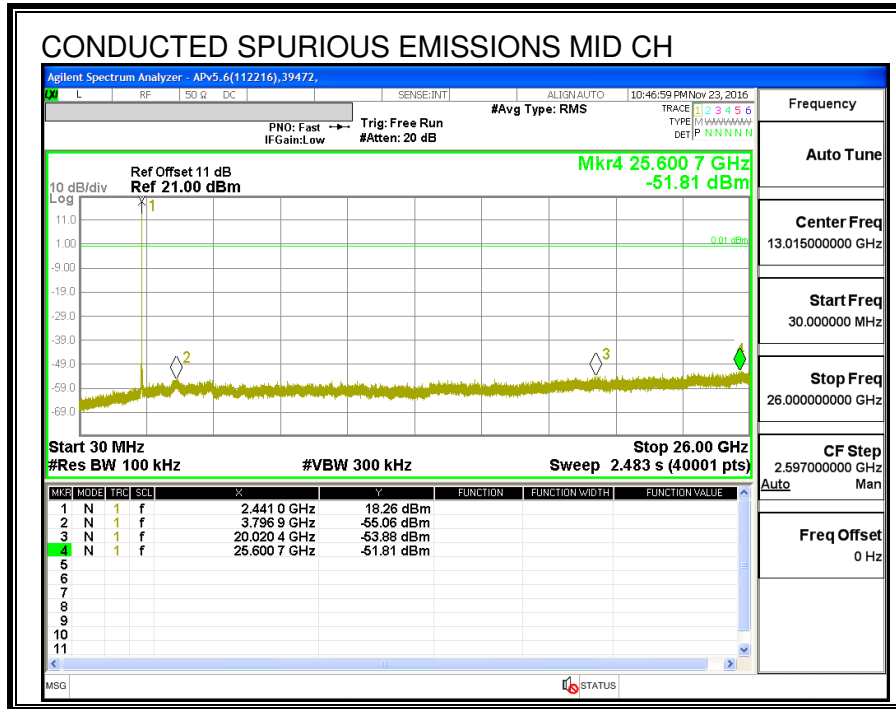

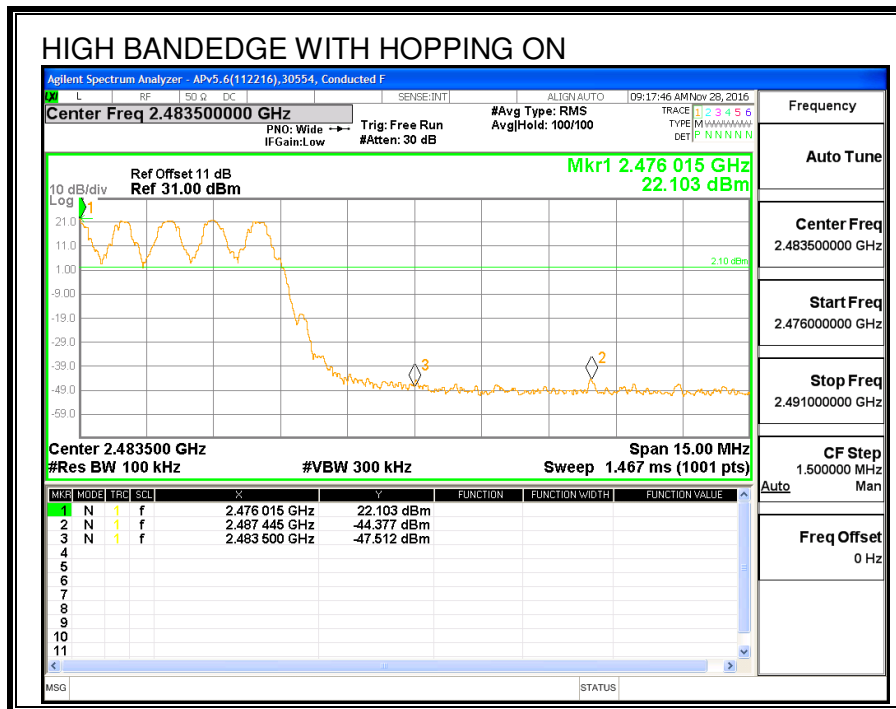
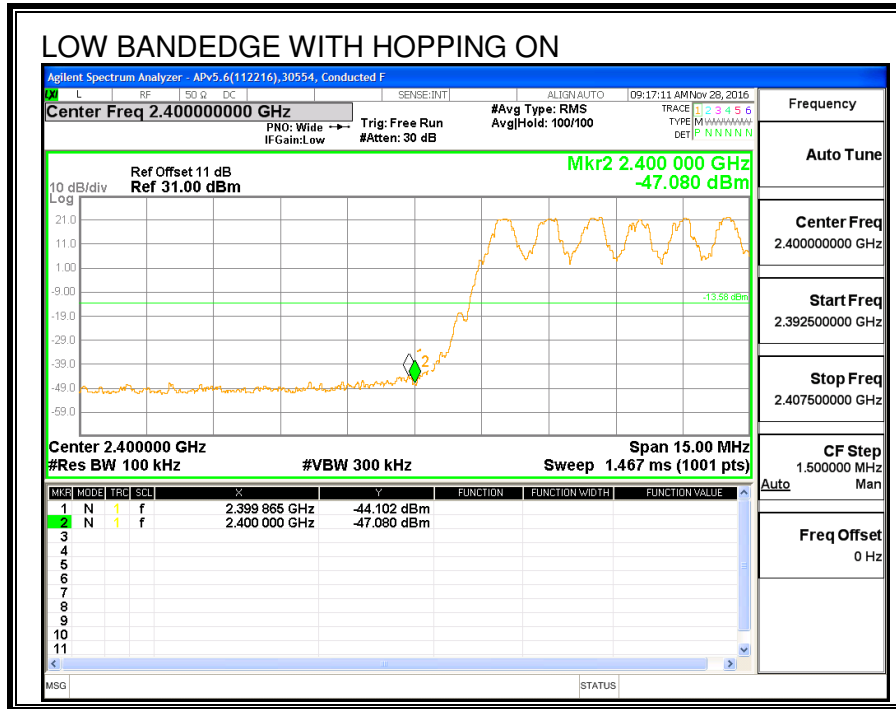

### 8.3. HIGH POWER ENHANCED DATA RATE DQPSK MODULATION

#### 8.3.1. OUTPUT POWER

<b>ID:</b>	43578	<b>Date:</b>	1/19/17
------------	-------	--------------	---------

#### LIMITS

§15.247 (b) (1)

RSS-247 (5.4) (2)

The maximum antenna gain is less than 6 dBi, therefore the limit is 30 dBm.

#### TEST PROCEDURE

The transmitter output is connected to a wideband peak and average power meter.

#### RESULTS

Channel	Frequency (MHz)	Output Power (dBm)	Limit (dBm)	Margin (dB)
Low	2402	17.68	21	-3.32
Middle	2441	17.51	21	-3.49
High	2480	17.70	21	-3.30

### 8.3.2. AVERAGE POWER

<b>ID:</b>	43578	<b>Date:</b>	1/19/17
------------	-------	--------------	---------

#### LIMITS

None; for reporting purposes only.

#### TEST PROCEDURE

The transmitter output is connected to a power meter.

#### RESULTS

The cable assembly insertion loss of 11 dB (including 10 dB pad and 1 dB cable) was entered as an offset in the power meter to allow for direct reading of power.

Channel	Frequency (MHz)	Average Power (dBm)
Low	2402	14.41
Middle	2441	14.25
High	2480	14.45

---

## 8.4. HIGH POWER ENHANCED DATA RATE 8PSK MODULATION

### 8.4.1. 20 dB AND 99% BANDWIDTH

#### LIMITS

None; for reporting purposes only.

#### TEST PROCEDURE

The transmitter output is connected to a spectrum analyzer. The RBW is set to  $\geq 1\%$  of the 20 dB bandwidth. The VBW is set to  $\geq$  RBW. The sweep time is coupled.

#### RESULTS

Channel	Frequency (MHz)	20 dB Bandwidth (KHz)	99% Bandwidth (KHz)
Low	2402	1364	1220.1
Middle	2441	1314	1228.4
High	2480	1299	1202.1

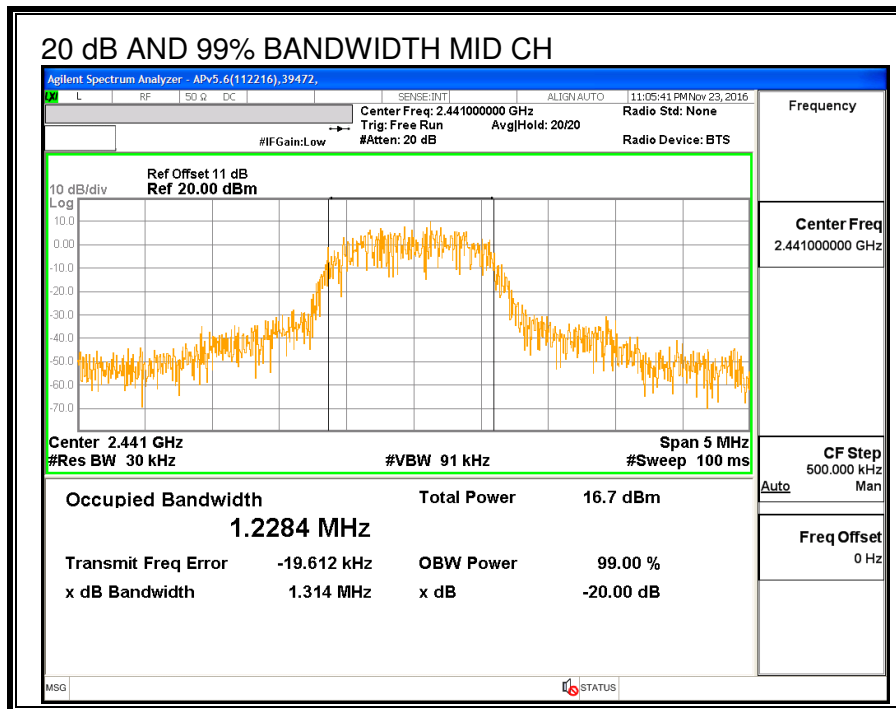
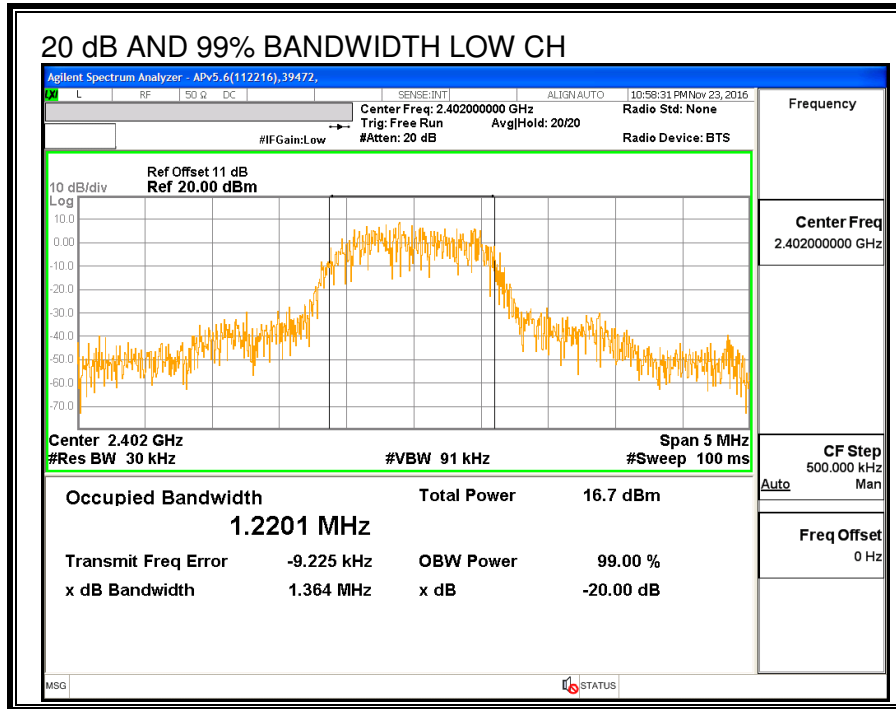

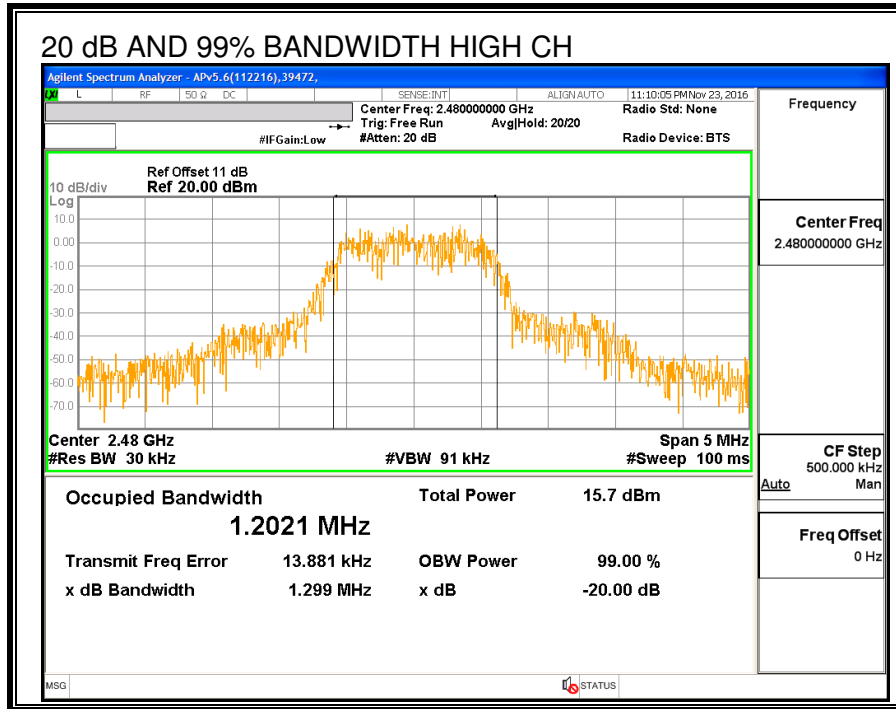

### 8.4.2. HOPPING FREQUENCY SEPARATION

#### LIMITS

FCC §15.247 (a) (1)

IC RSS-247 (5.1) (2)

Frequency hopping systems shall have hopping channel carrier frequencies separated by a minimum of 25 kHz or the 20 dB bandwidth of the hopping channel, whichever is greater.

Alternatively, frequency hopping systems operating in the 2400-2483.5 MHz band may have hopping channel carrier frequencies that are separated by 25 kHz or two-thirds of the 20 dB bandwidth of the hopping channel, whichever is greater, provided the systems operate with an output power no greater than 125 mW.

#### TEST PROCEDURE

The transmitter output is connected to a spectrum analyzer. The RBW is set to 300 kHz and the VBW is set to 910 kHz. The sweep time is coupled.

#### RESULTS

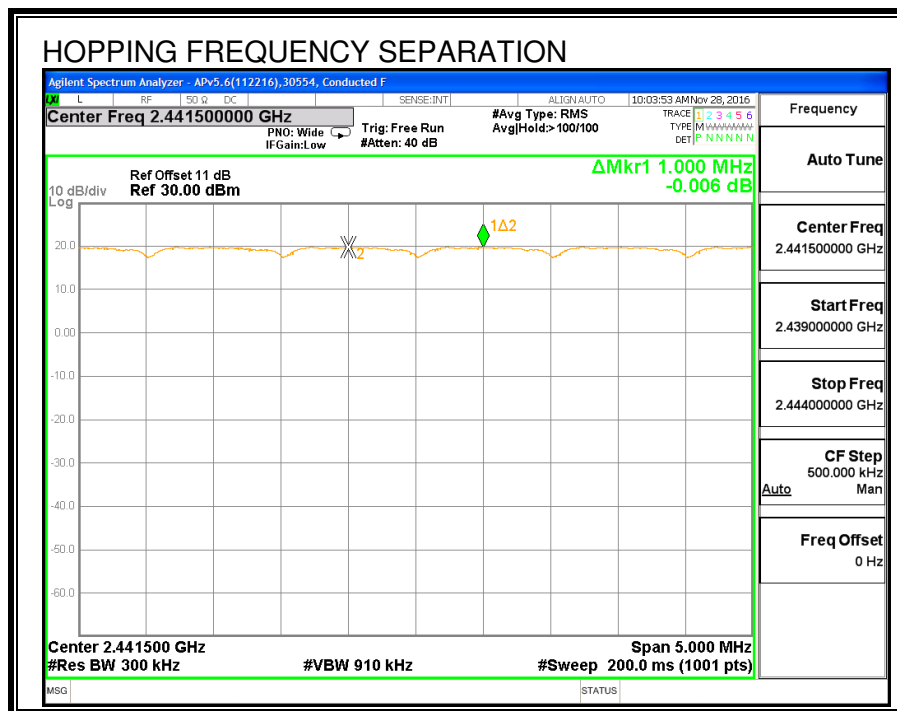

### 8.4.3. NUMBER OF HOPPING CHANNELS

#### LIMITS

FCC §15.247 (a) (1) (iii)

IC RSS-247 (5.1) (4)

Frequency hopping systems in the 2400 – 2483.5 MHz band shall use at least 15 non-overlapping channels.

#### TEST PROCEDURE

The transmitter output is connected to a spectrum analyzer. The span is set to cover the entire authorized band, in either a single sweep or in multiple contiguous sweeps. The RBW is set to a maximum of 1 % of the span. The analyzer is set to Max Hold.

#### RESULTS

Normal Mode: 79 Channels observed.

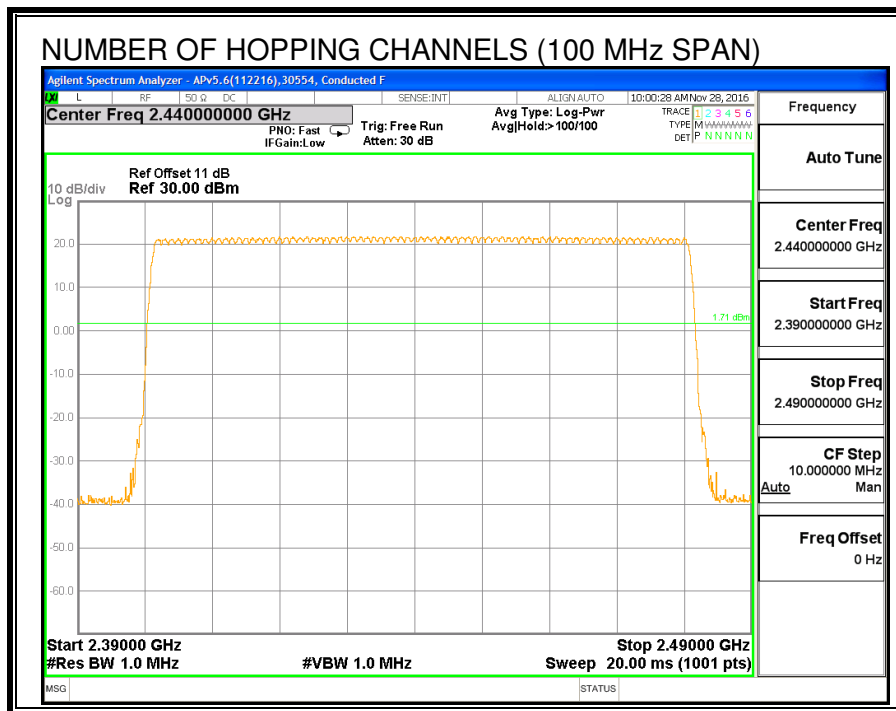

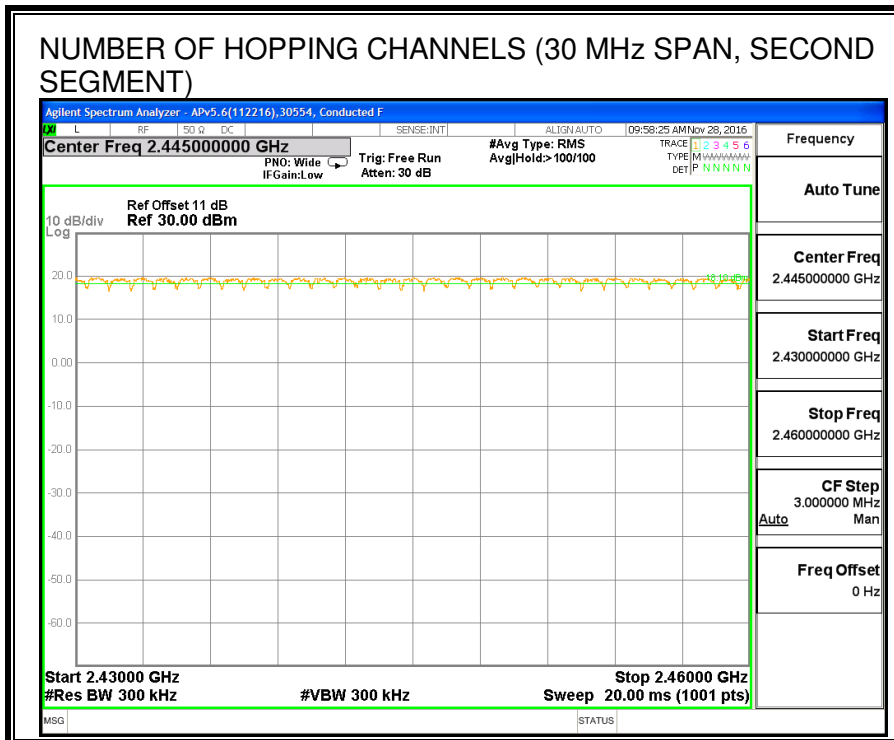
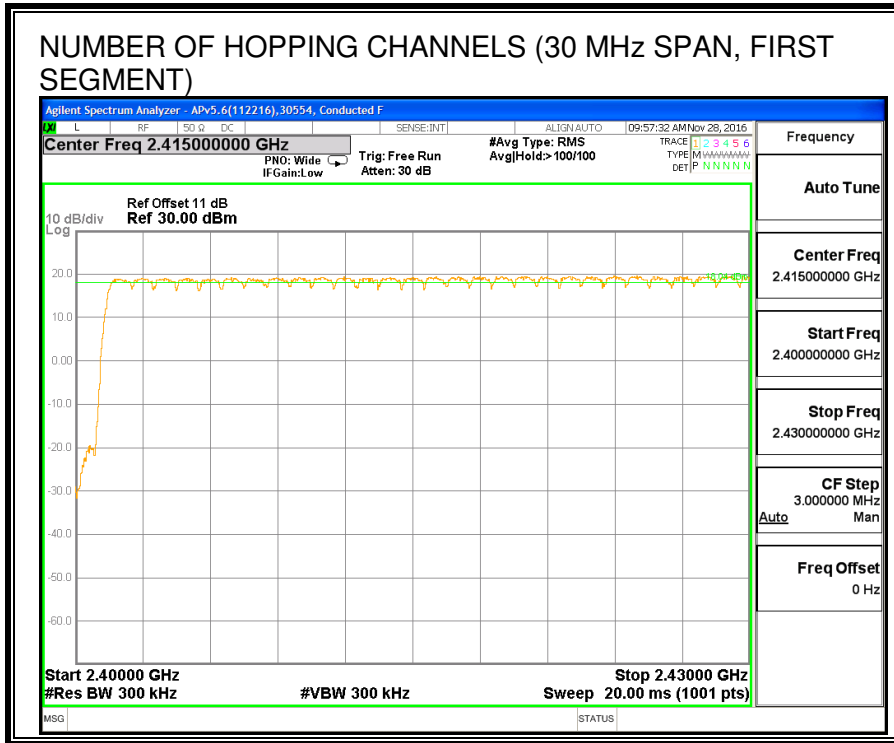

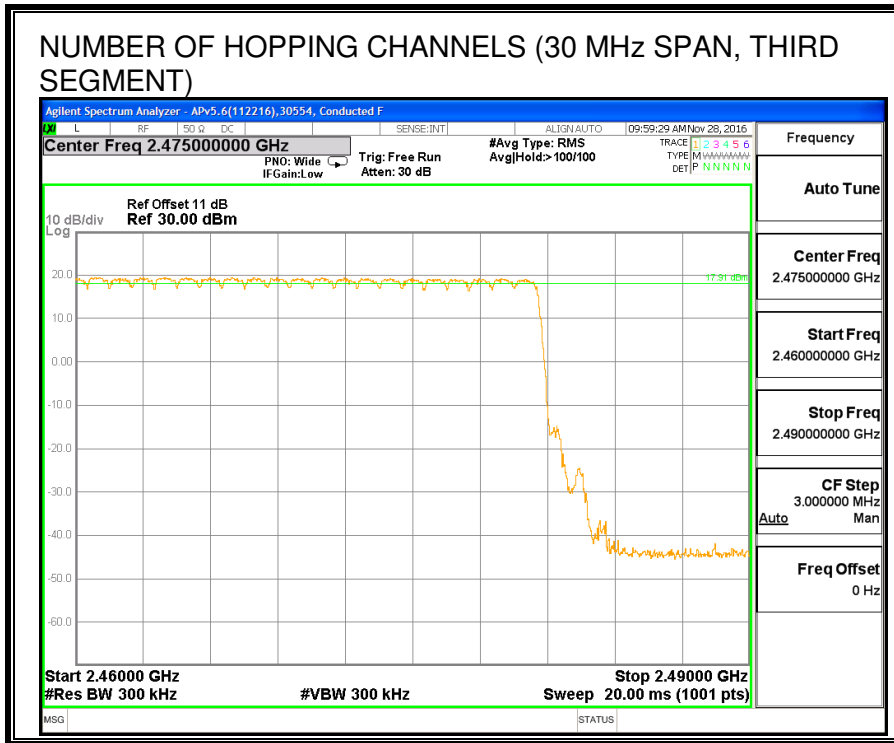

### 8.4.4. AVERAGE TIME OF OCCUPANCY

#### LIMITS

FCC §15.247 (a) (1) (iii)

IC RSS-247 (5.1) (4)

The average time of occupancy on any channel shall not be greater than 0.4 seconds within a period of 0.4 seconds multiplied by the number of hopping channels employed.

#### TEST PROCEDURE

The transmitter output is connected to a spectrum analyzer. The span is set to 0 Hz, centered on a single, selected hopping channel. The width of a single pulse is measured in a fast scan. The number of pulses is measured in a 3.16 second scan, to enable resolution of each occurrence.

The average time of occupancy in the specified 31.6 second period (79 channels \* 0.4 s) is equal to  $10 * (\# \text{ of pulses in } 3.16 \text{ s}) * \text{ pulse width}$ .

#### RESULTS

DH Packet	Pulse Width (msec)	Number of Pulses in 3.16 seconds	Average Time of Occupancy (sec)	Limit (sec)	Margin (sec)
8PSK (EDR) Mode					
3DH1	0.401	31	0.124	0.4	-0.276
3DH3	1.652	17	0.281	0.4	-0.119
3DH5	2.904	12	0.348	0.4	-0.052

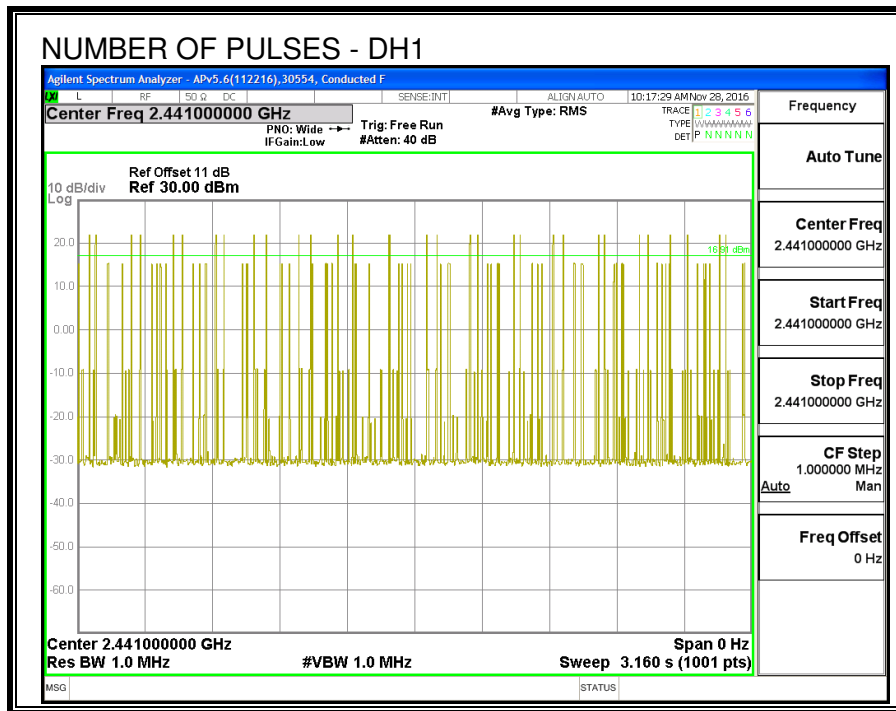

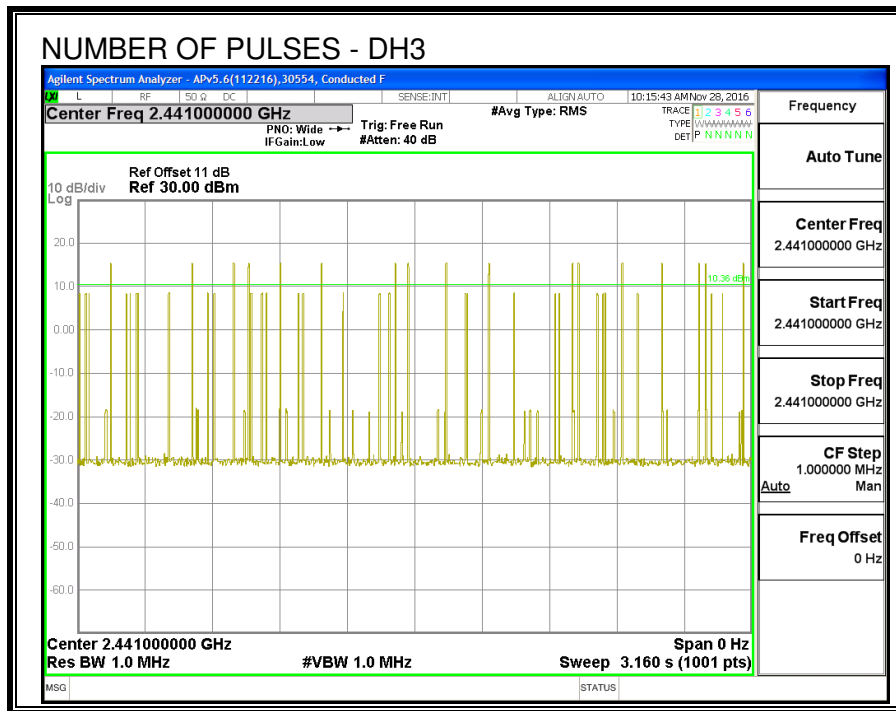
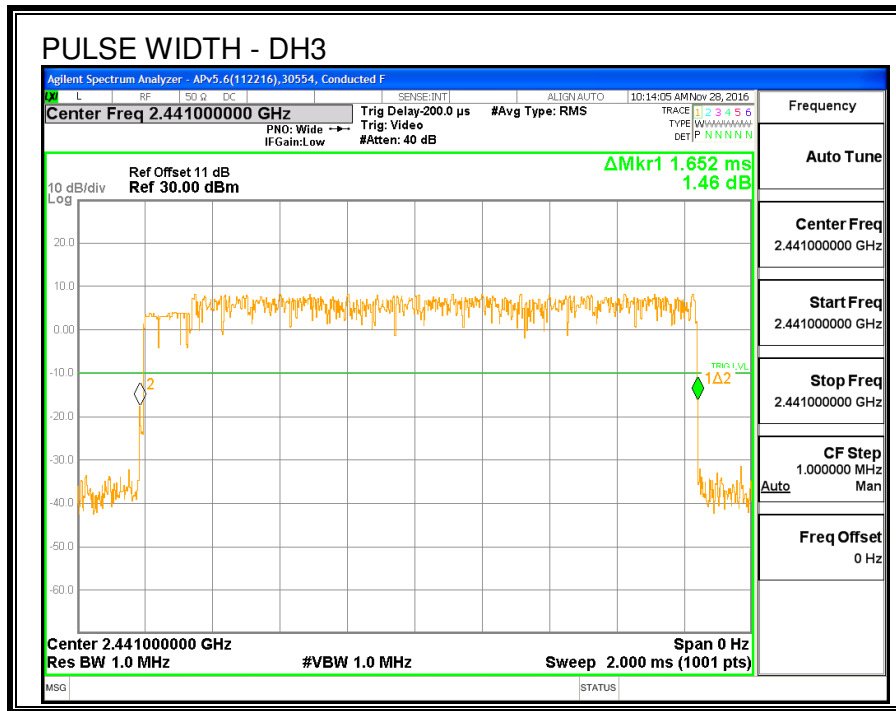

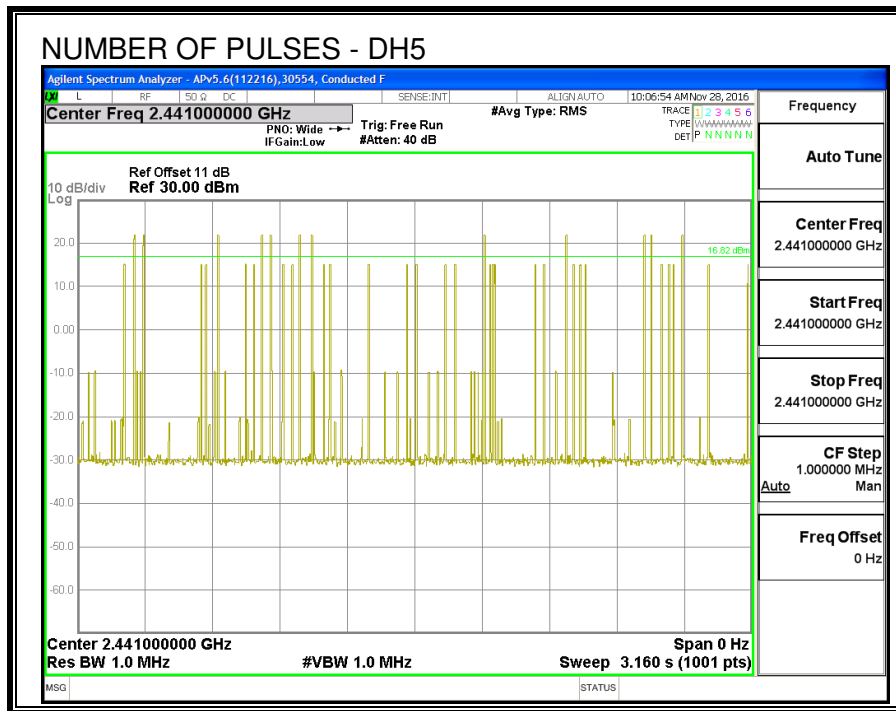
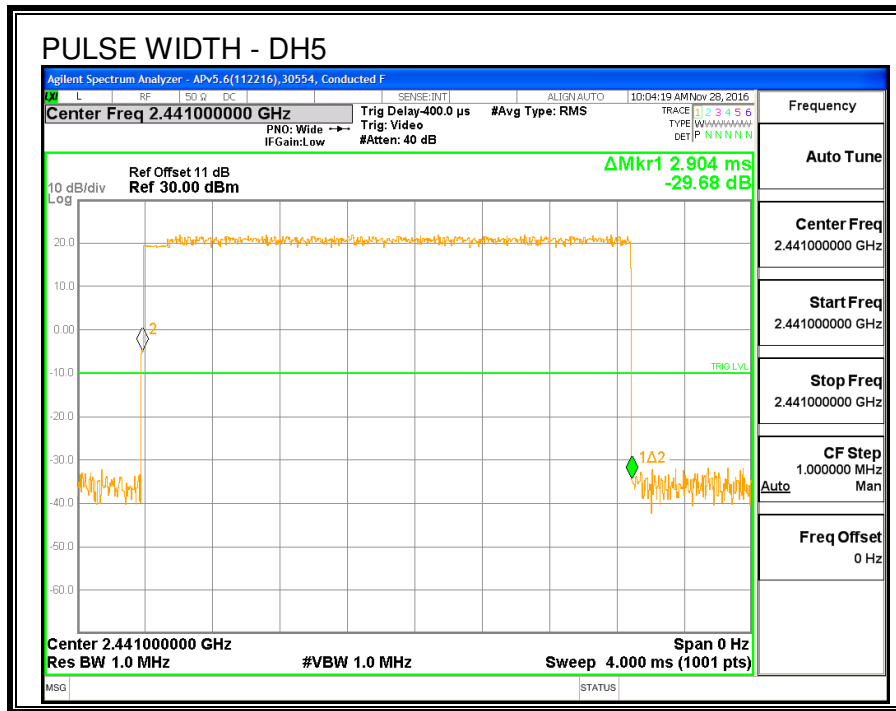

### 8.4.5. OUTPUT POWER

<b>ID:</b>	43578	<b>Date:</b>	1/19/17
------------	-------	--------------	---------

#### LIMITS

§15.247 (b) (1)

RSS-247 (5.4) (2)

The maximum antenna gain is less than 6 dBi, therefore the limit is 30 dBm.

#### TEST PROCEDURE

The transmitter output is connected to a wideband peak and average power meter.

#### RESULTS

Channel	Frequency (MHz)	Output Power (dBm)	Limit (dBm)	Margin (dB)
Low	2402	17.82	21	-3.18
Middle	2441	17.60	21	-3.40
High	2480	17.83	21	-3.17

---

### 8.4.6. AVERAGE POWER

<b>ID:</b>	43578	<b>Date:</b>	1/19/17
------------	-------	--------------	---------

#### LIMITS

None; for reporting purposes only.

#### TEST PROCEDURE

The transmitter output is connected to a power meter.

#### RESULTS

The cable assembly insertion loss of 11 dB (including 10 dB pad and 1 dB cable) was entered as an offset in the power meter to allow for direct reading of power.

Channel	Frequency (MHz)	Average Power (dBm)
Low	2402	14.47
Middle	2441	14.31
High	2480	14.50

### 8.4.7. CONDUCTED BANDEDGE AND SPURIOUS EMISSIONS

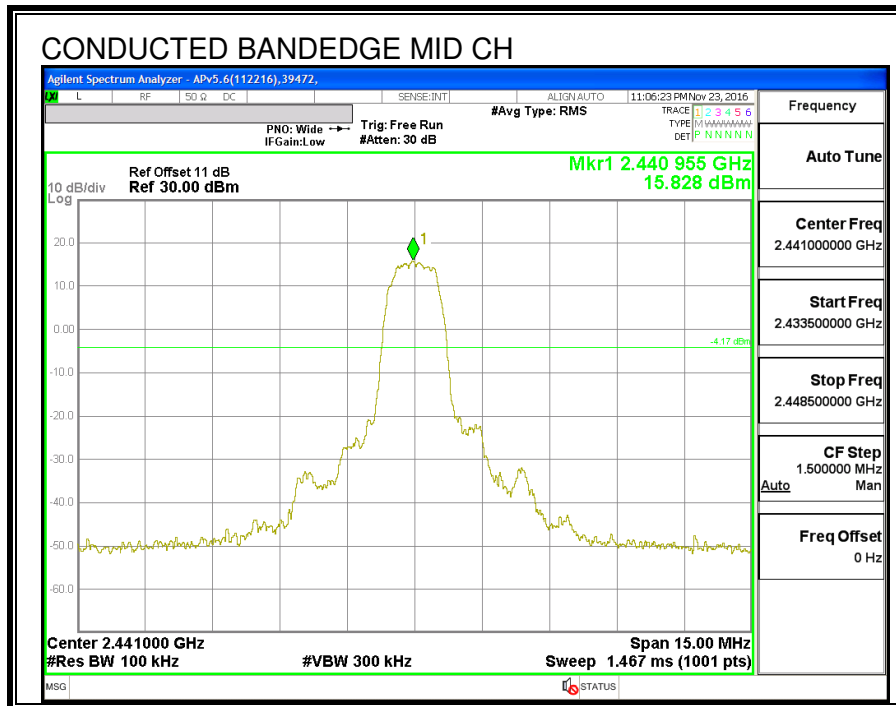
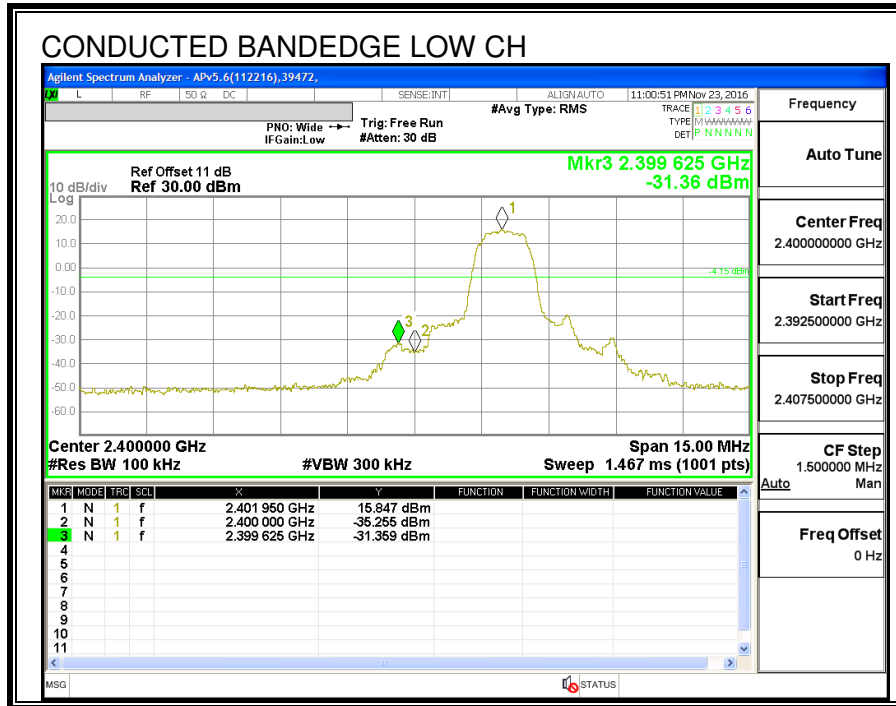

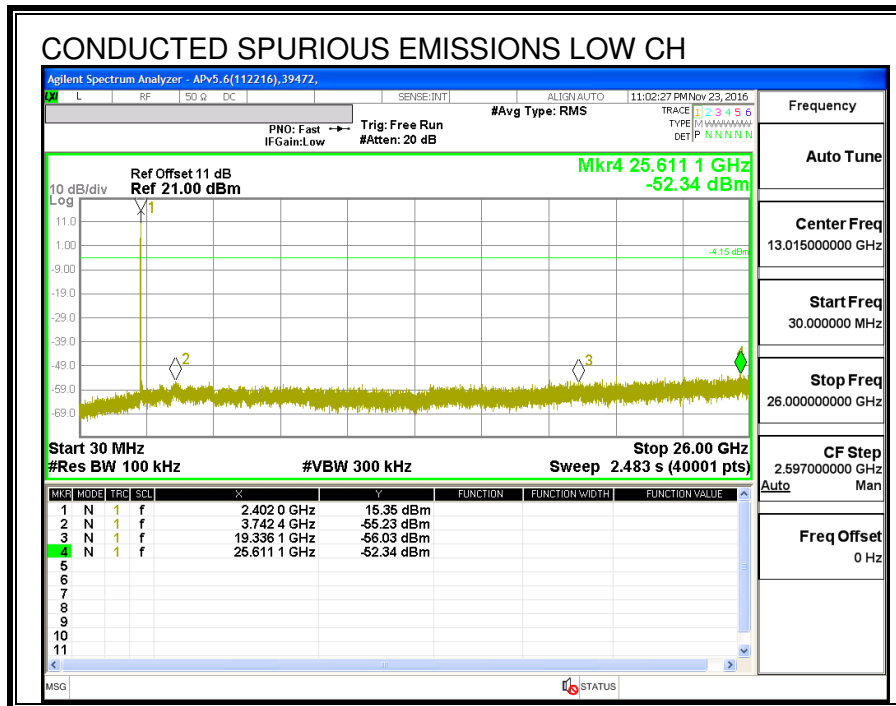
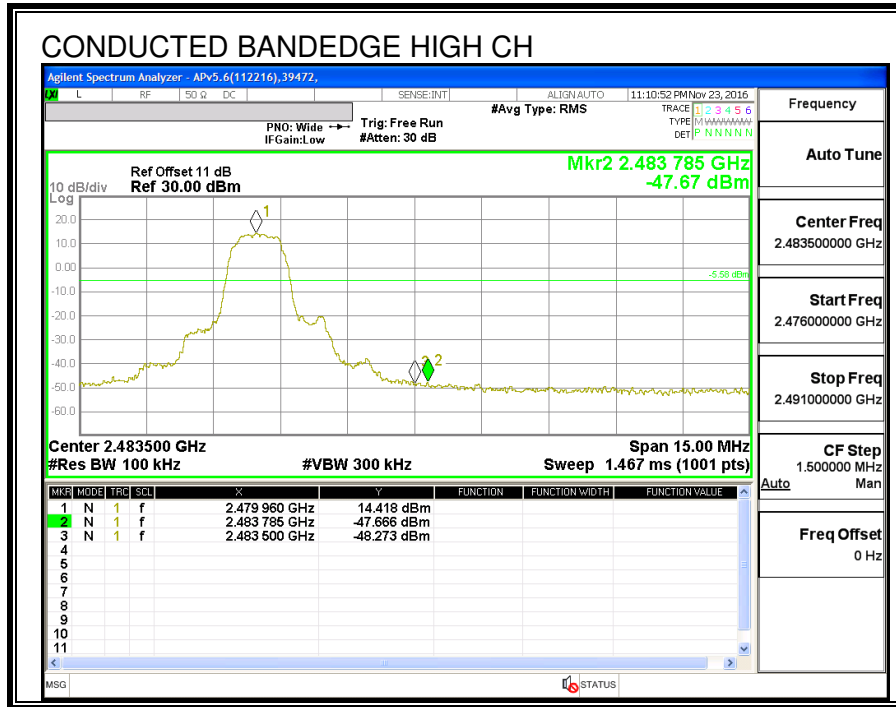

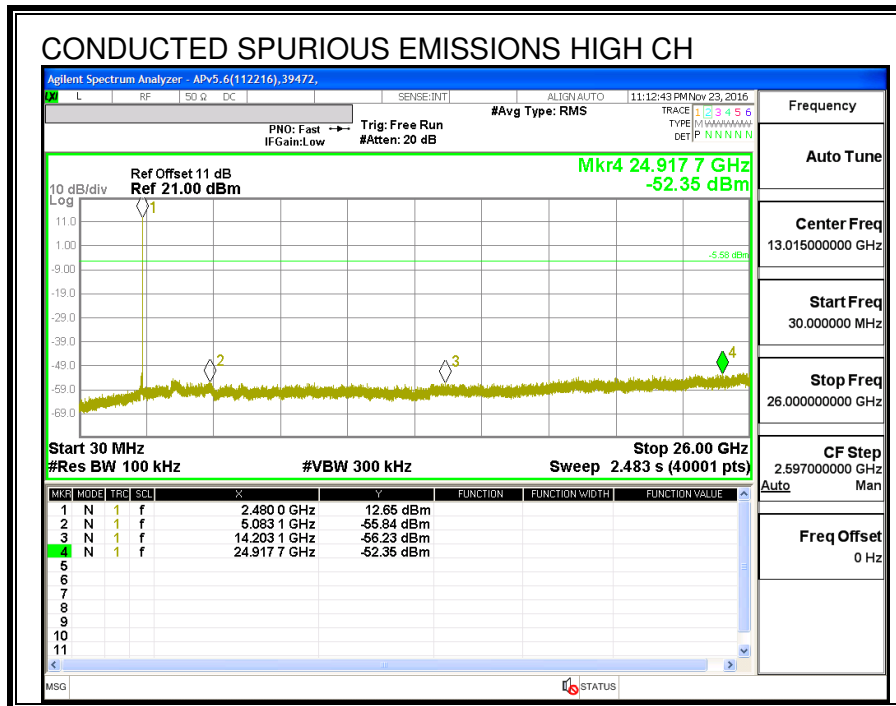
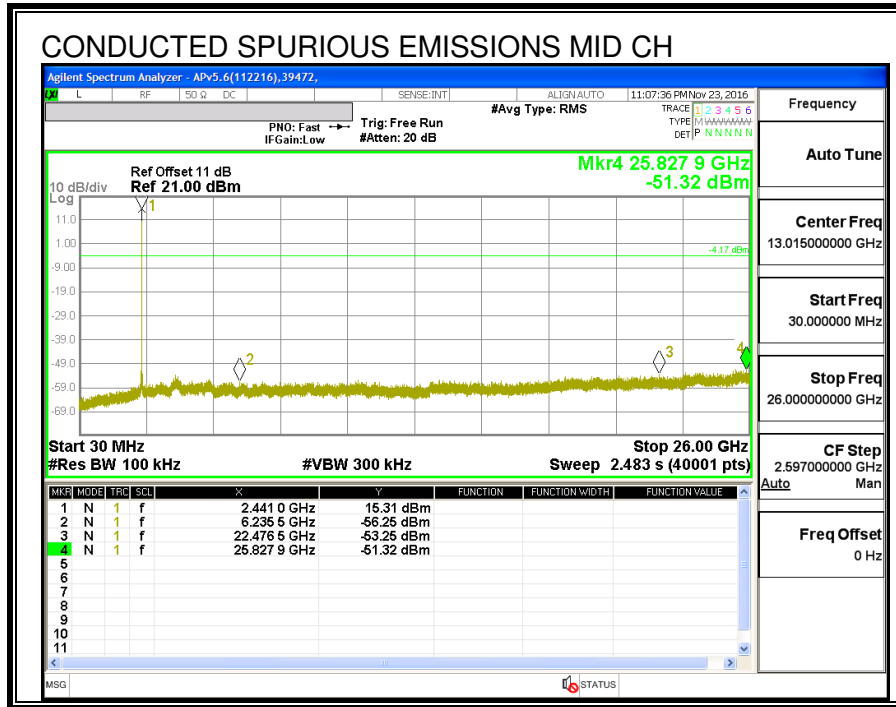

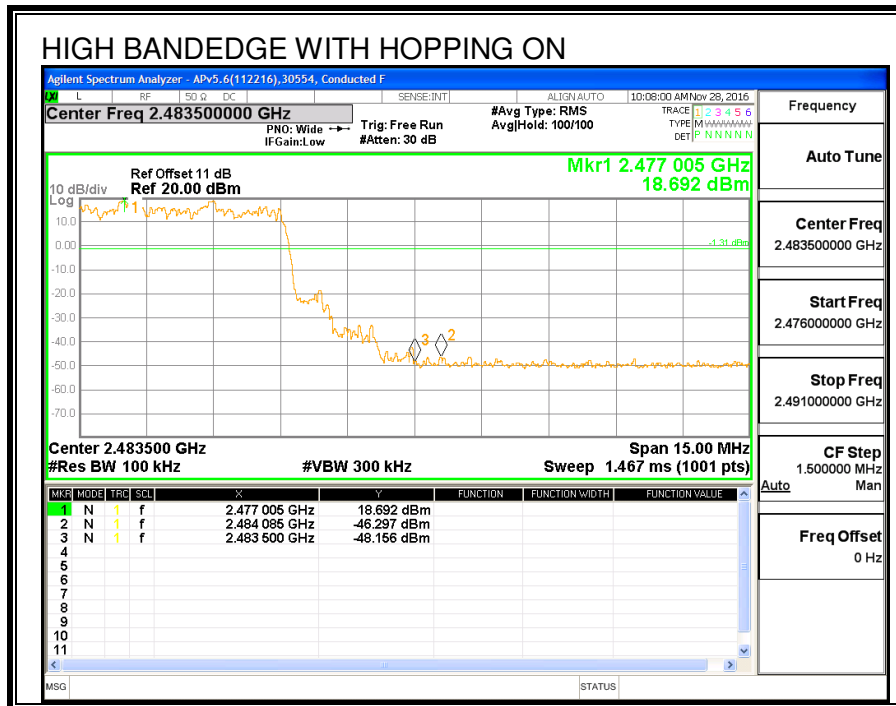
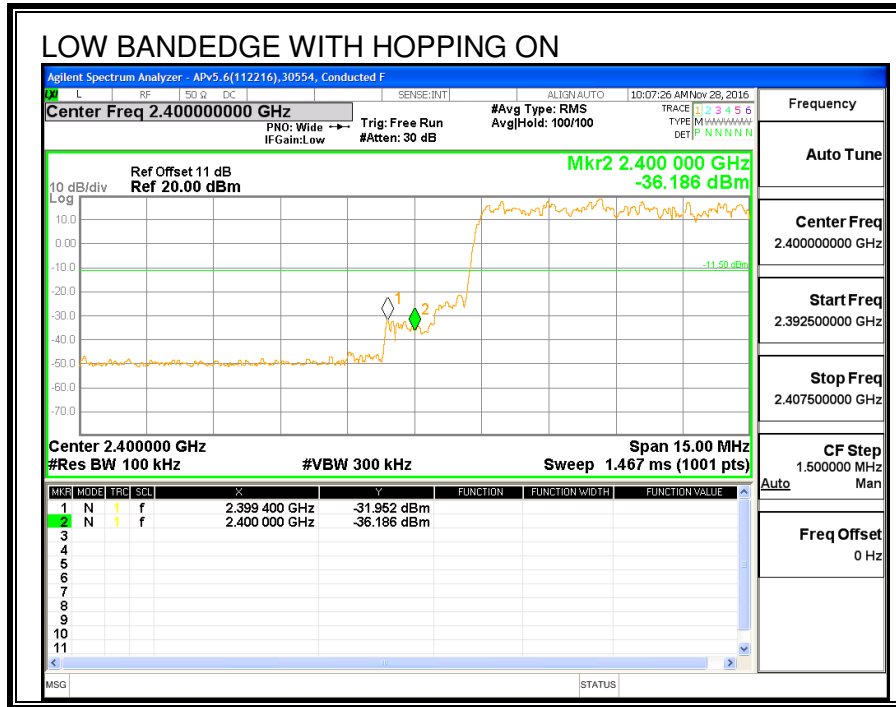

## 8.5. LOW POWER BASIC DATA RATE GFSK MODULATION

### 8.5.1. 20 dB AND 99% BANDWIDTH

#### LIMITS

None; for reporting purposes only.

#### TEST PROCEDURE

The transmitter output is connected to a spectrum analyzer. The RBW is set to  $\geq 1\%$  of the 20 dB bandwidth. The VBW is set to  $\geq$  RBW. The sweep time is coupled.

#### RESULTS

Channel	Frequency (MHz)	20 dB Bandwidth (KHz)	99% Bandwidth (KHz)
Low	2402	852.8	885.47
Middle	2441	848.0	884.29
High	2480	936.5	874.95

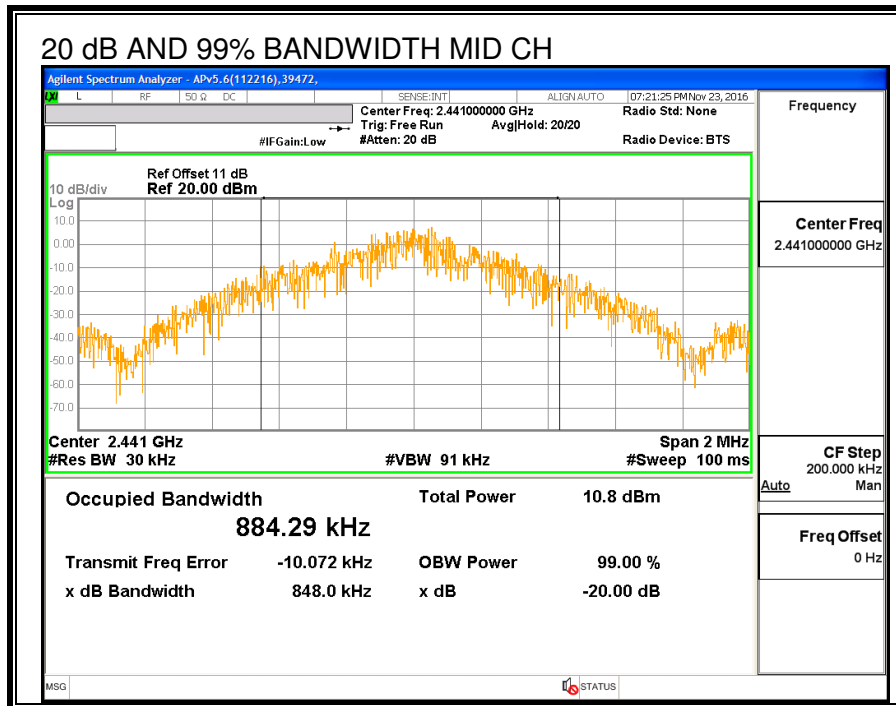
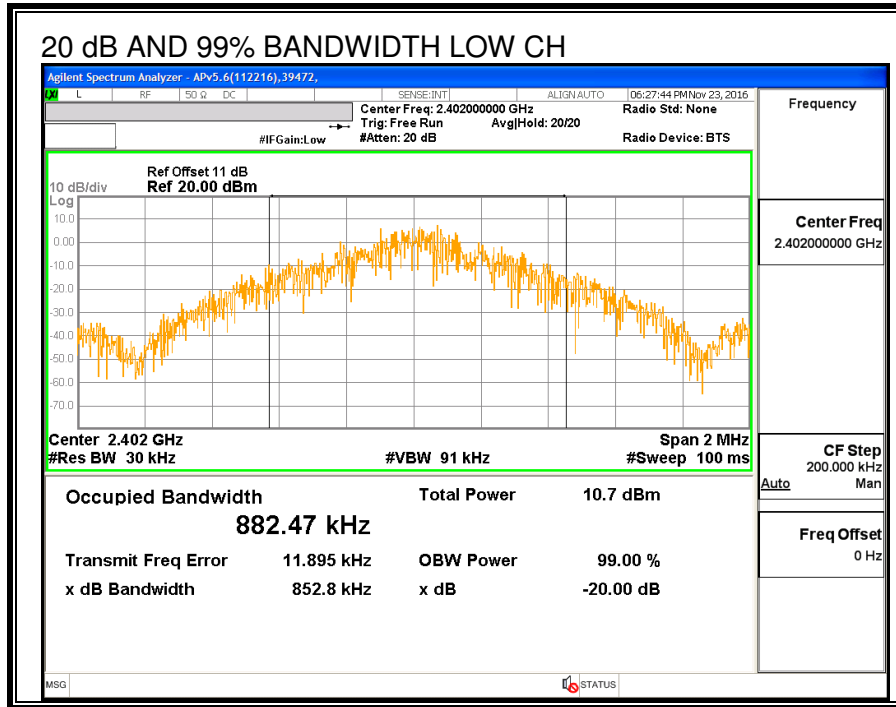

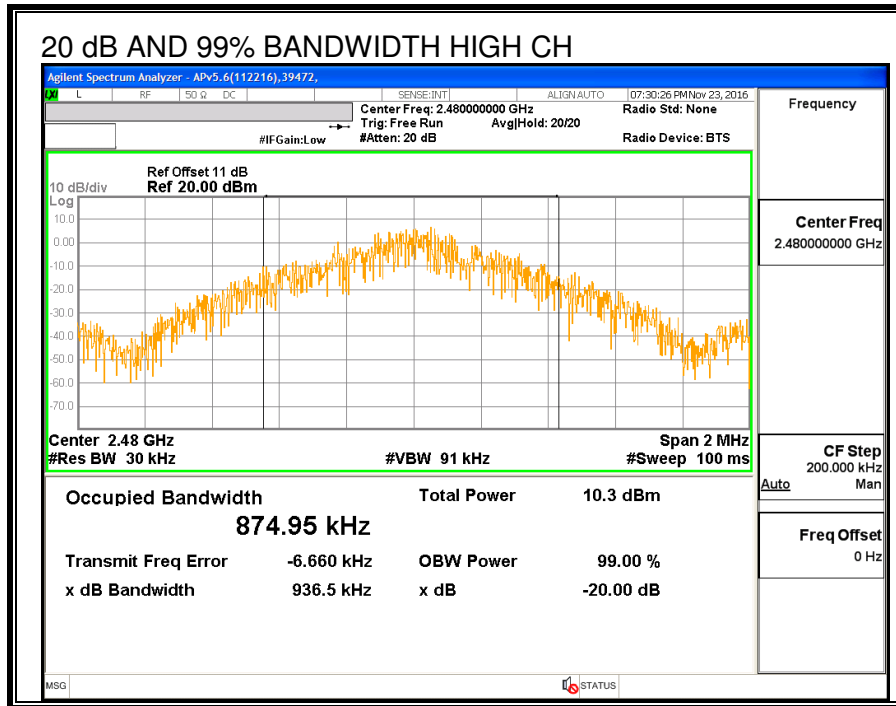



### 8.5.3. NUMBER OF HOPPING CHANNELS

#### LIMITS

FCC §15.247 (a) (1) (iii)

IC RSS-247 (5.1) (4)

Frequency hopping systems in the 2400 – 2483.5 MHz band shall use at least 15 non-overlapping channels.

#### TEST PROCEDURE

The transmitter output is connected to a spectrum analyzer. The span is set to cover the entire authorized band, in either a single sweep or in multiple contiguous sweeps. The RBW is set to a maximum of 1 % of the span. The analyzer is set to Max Hold.

#### RESULTS

Normal Mode: 79 Channels observed.

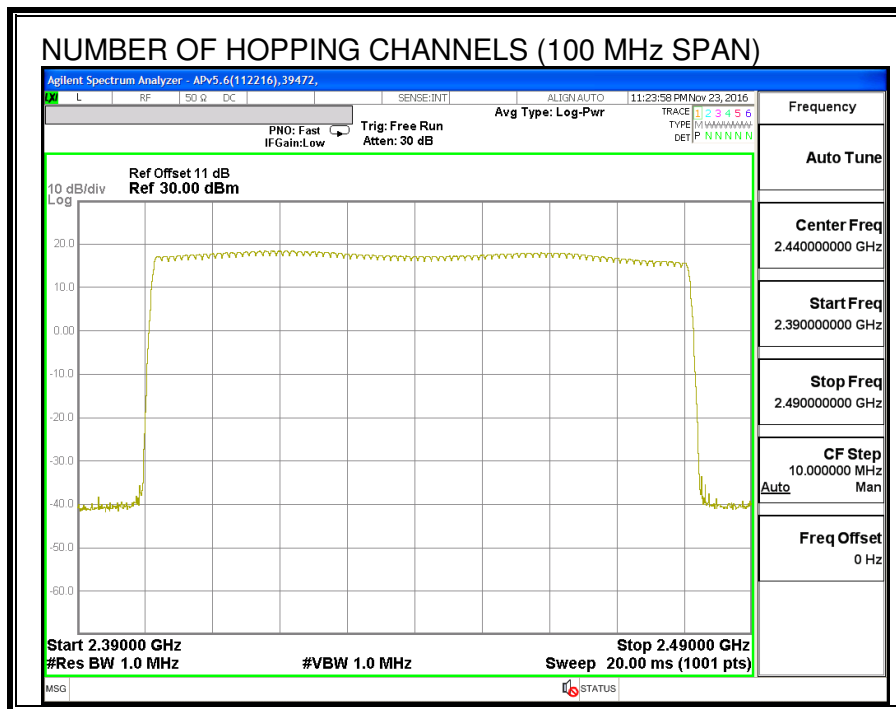

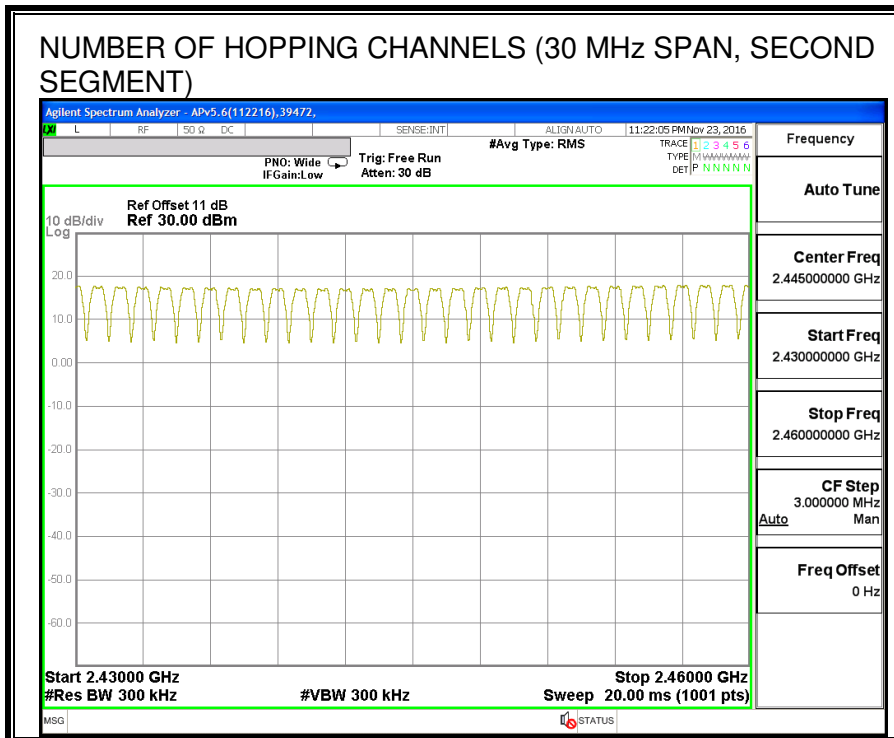
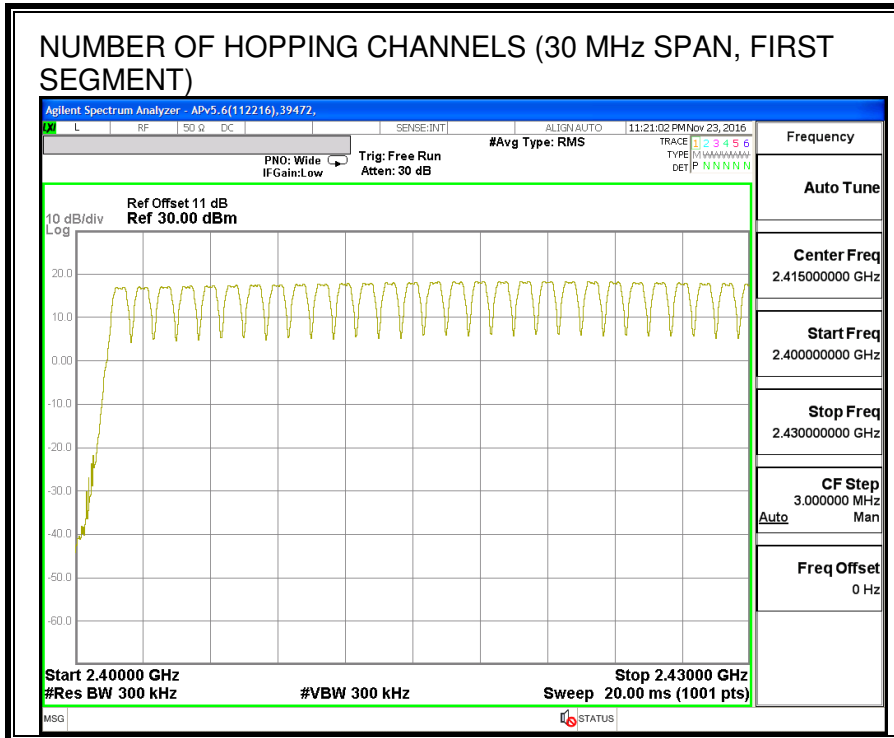

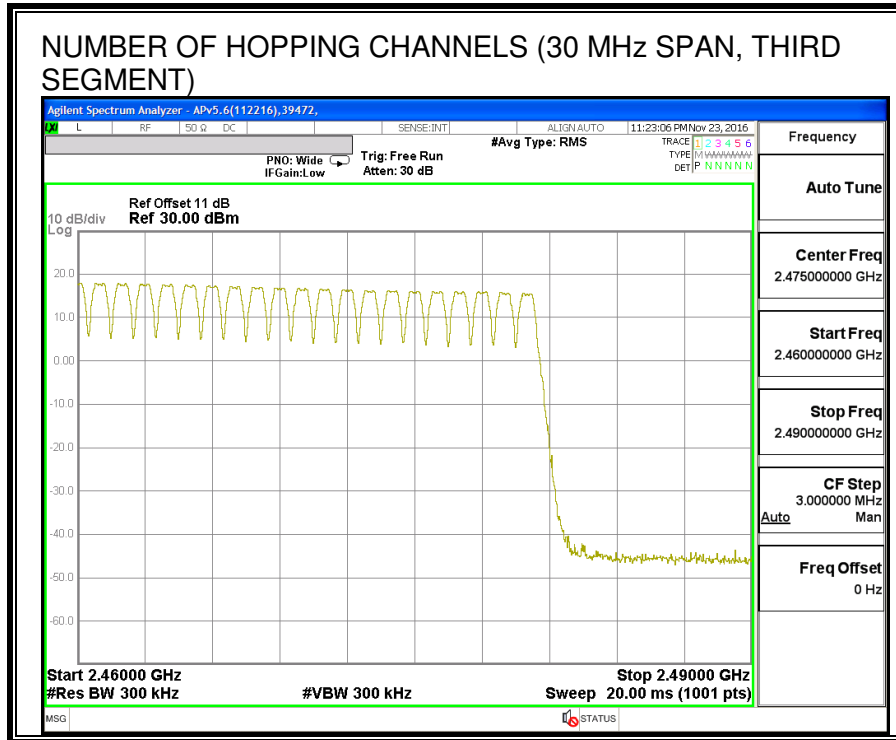

**8.5.4. AVERAGE TIME OF OCCUPANCY**

**LIMITS**

FCC §15.247 (a) (1) (iii)

IC RSS-247 (5.1) (4)

The average time of occupancy on any channel shall not be greater than 0.4 seconds within a period of 0.4 seconds multiplied by the number of hopping channels employed.

**TEST PROCEDURE**

The transmitter output is connected to a spectrum analyzer. The span is set to 0 Hz, centered on a single, selected hopping channel. The width of a single pulse is measured in a fast scan. The number of pulses is measured in a 3.16 second scan, to enable resolution of each occurrence.

The average time of occupancy in the specified 31.6 second period (79 channels \* 0.4 s) is equal to  $10 * (\# \text{ of pulses in } 3.16 \text{ s}) * \text{ pulse width}$ .

For AFH mode, the average time of occupancy in the specified 8 second period (20 channels \* 0.4 seconds) is equal to  $10 * (\# \text{ of pulses in } 0.8 \text{ s}) * \text{ pulse width}$ .

**RESULTS**

DH Packet	Pulse Width (msec)	Number of Pulses in 3.16 seconds	Average Time of Occupancy (sec)	Limit (sec)	Margin (sec)
<b>GFSK Normal Mode</b>					
DH1	0.393	32	0.126	0.4	-0.274
DH3	1.648	14	0.231	0.4	-0.169
DH5	2.896	9	0.261	0.4	-0.139
DH Packet	Pulse Width (msec)	Number of Pulses in 0.8 seconds	Average Time of Occupancy (sec)	Limit (sec)	Margin (sec)
<b>GFSK AFH Mode</b>					
DH1	0.393	8	0.031	0.4	-0.369
DH3	1.648	3.5	0.058	0.4	-0.342
DH5	2.896	2.25	0.065	0.4	-0.335

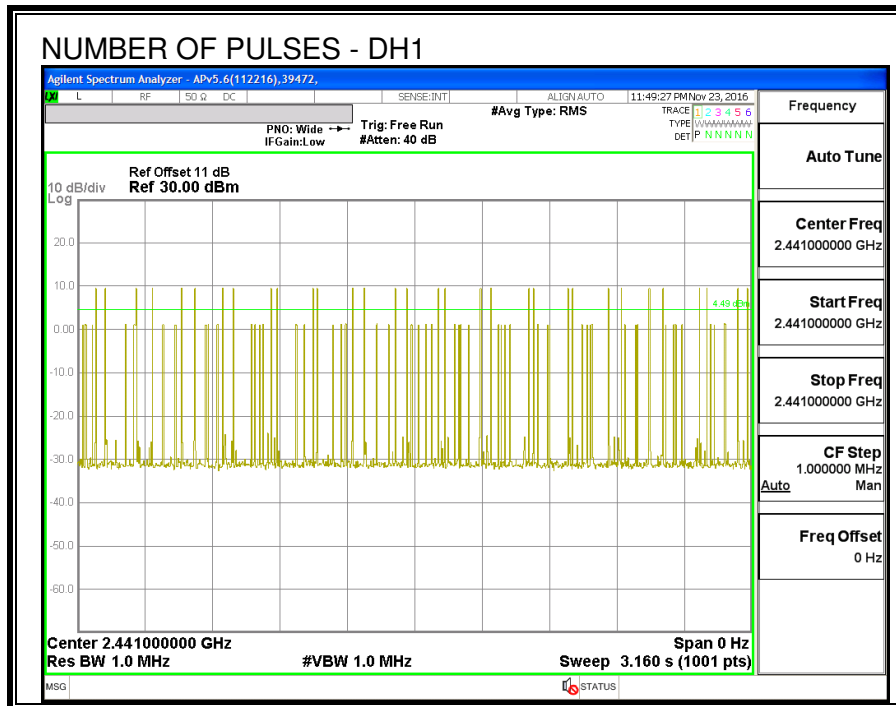

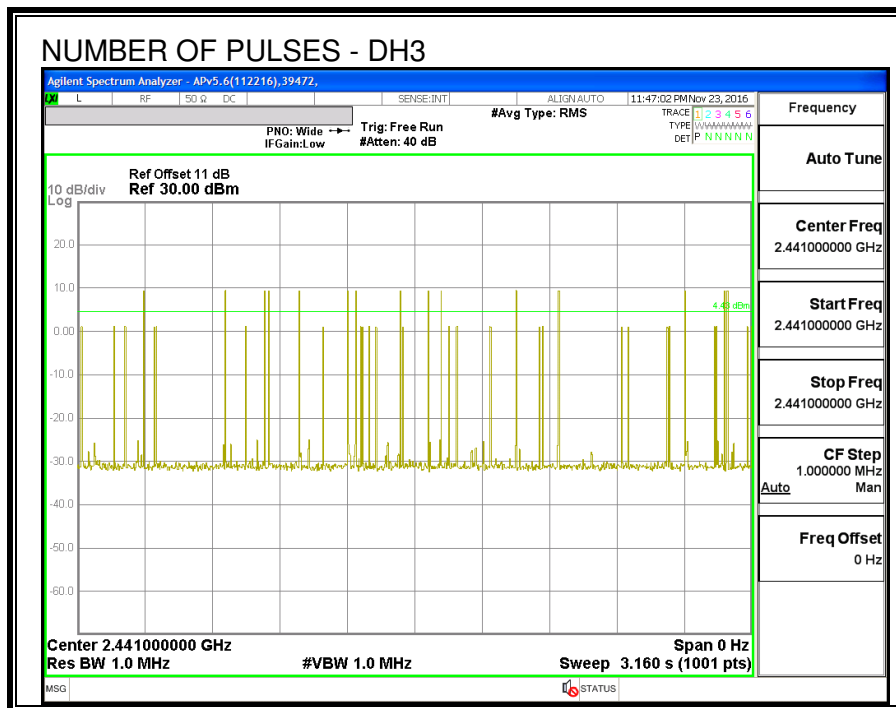
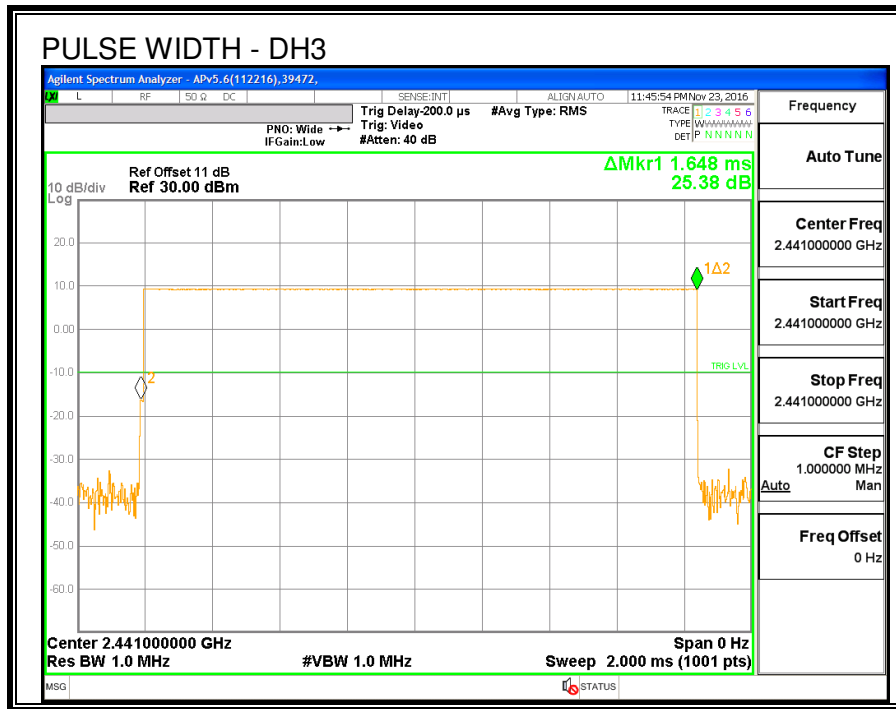

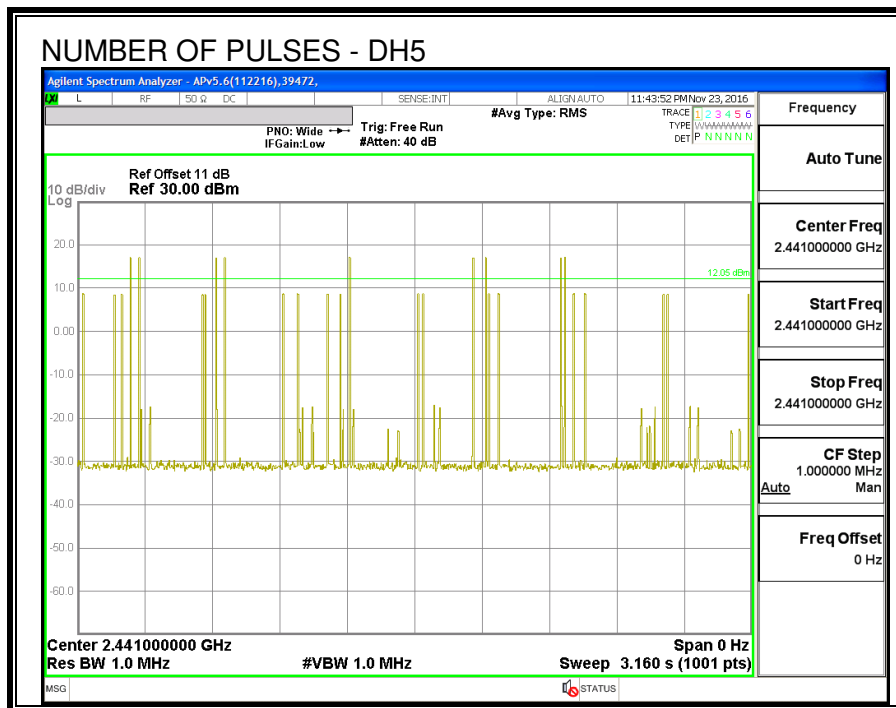
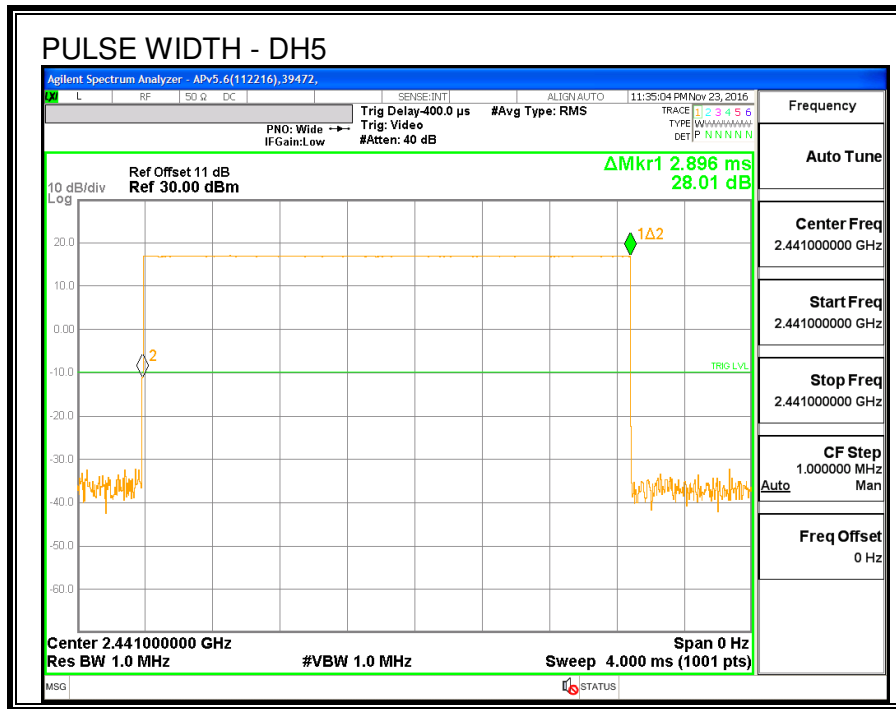

### 8.5.5. OUTPUT POWER

<b>ID:</b>	43578	<b>Date:</b>	1/19/17
------------	-------	--------------	---------

#### LIMITS

§15.247 (b) (1)

RSS-247 (5.4) (2)

The maximum antenna gain is less than 6 dBi, therefore the limit is 30 dBm.

#### TEST PROCEDURE

The transmitter output is connected to a wideband peak and average power meter.

#### RESULTS

Channel	Frequency (MHz)	Output Power (dBm)	Limit (dBm)	Margin (dB)
Low	2402	10.55	21	-10.45
Middle	2441	10.63	21	-10.37
High	2480	11.09	21	-9.91

### 8.5.6. AVERAGE POWER

<b>ID:</b>	43578	<b>Date:</b>	1/19/17
------------	-------	--------------	---------

#### LIMITS

None; for reporting purposes only.

#### TEST PROCEDURE

The transmitter output is connected to a power meter.

#### RESULTS

The cable assembly insertion loss of 11 dB (including 10 dB pad and 1 dB cable) was entered as an offset in the power meter to allow for direct reading of power.

Channel	Frequency (MHz)	Average Power (dBm)
Low	2402	10.37
Middle	2441	10.49
High	2480	10.34

### 8.5.7. CONDUCTED BANDEDGE AND SPURIOUS EMISSIONS

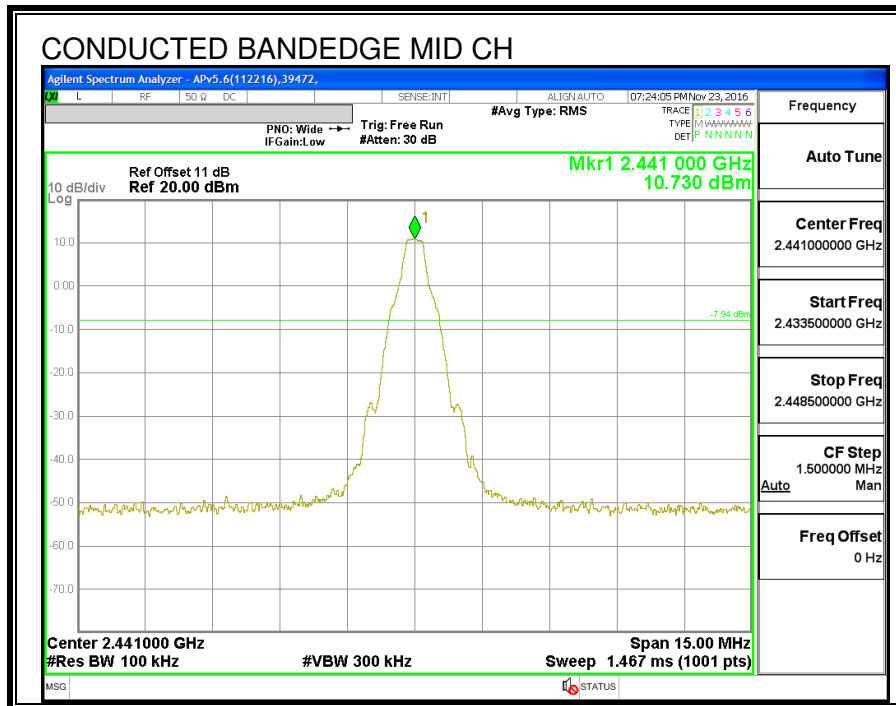
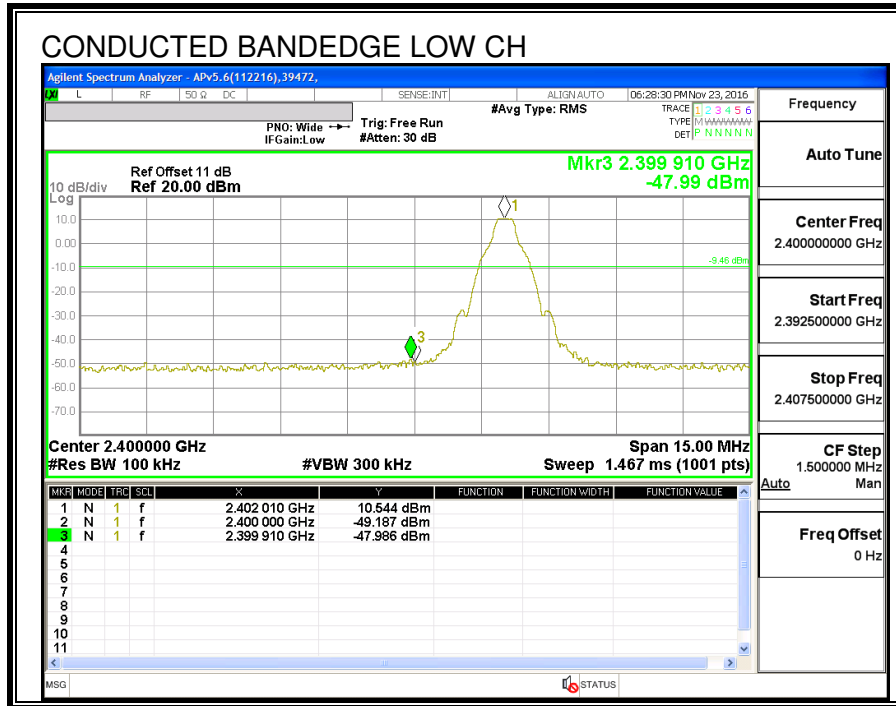

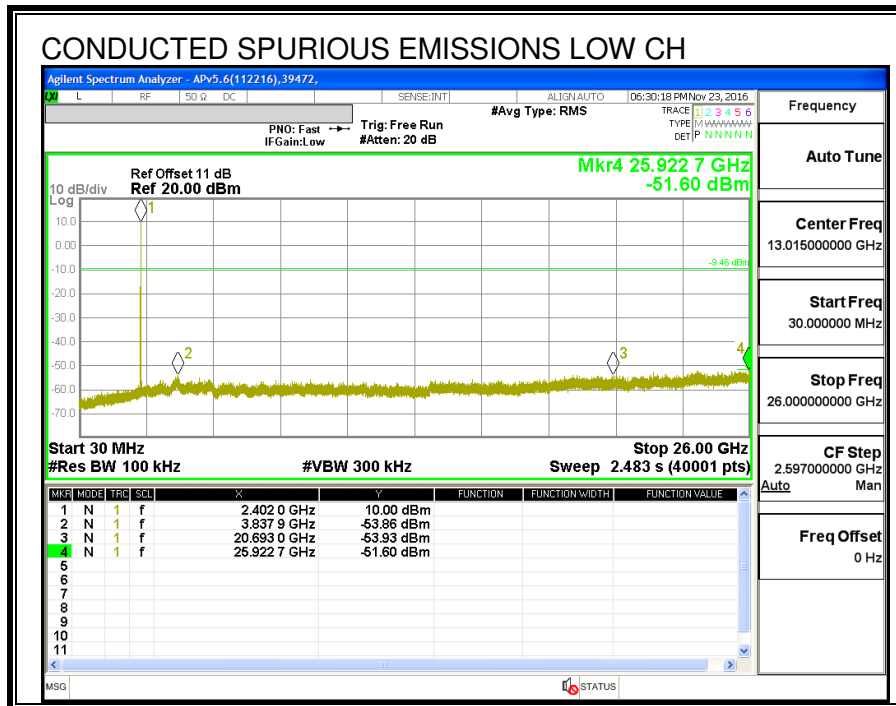
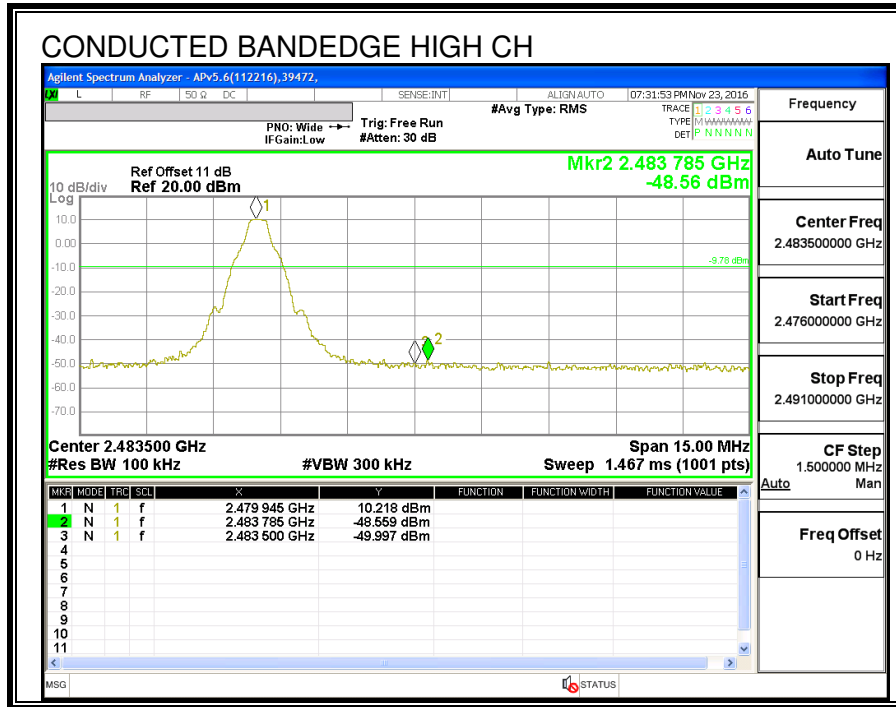

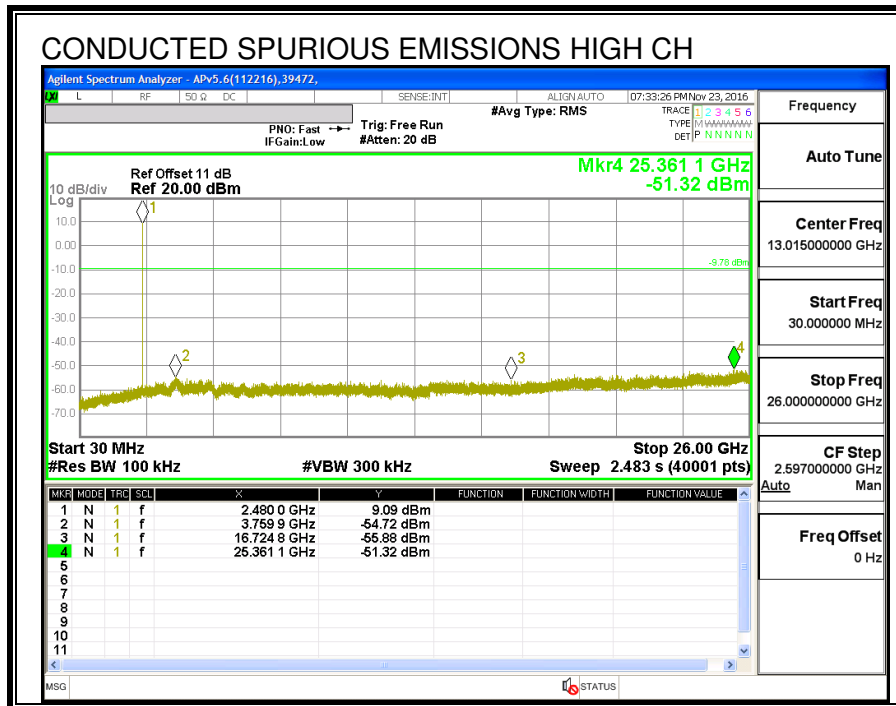
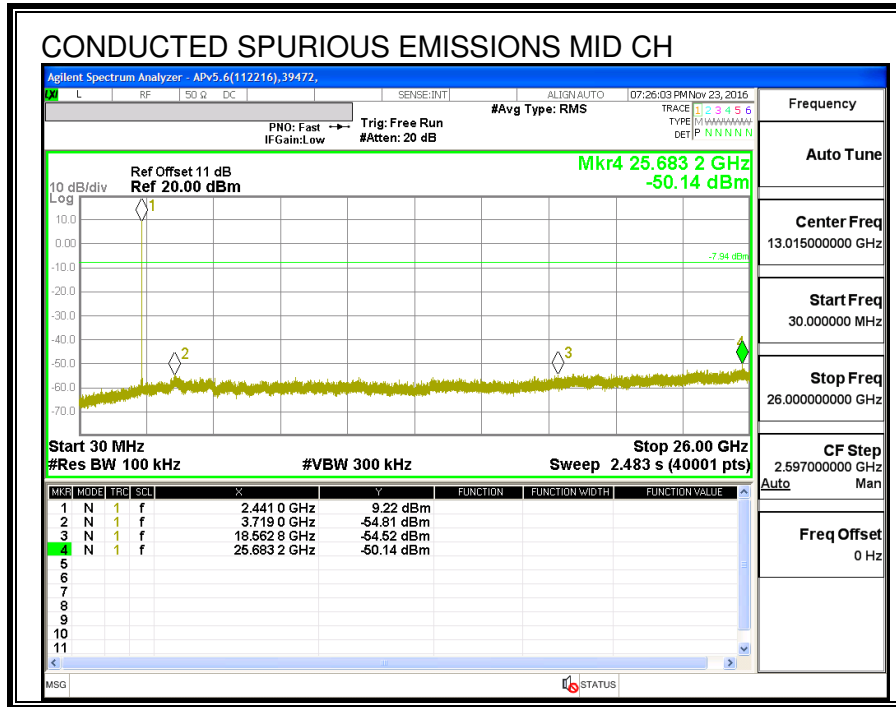

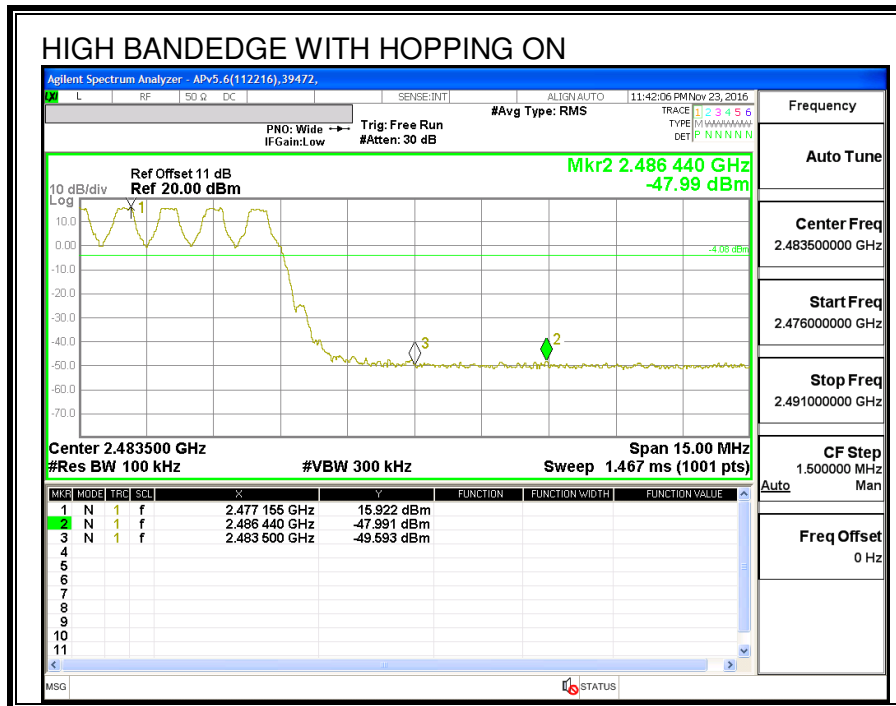
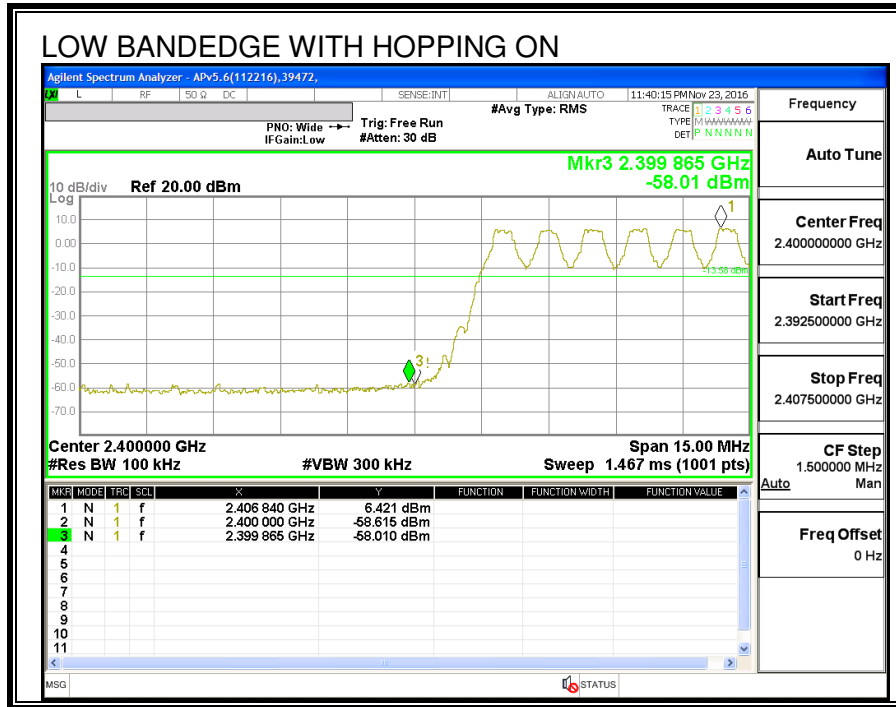

## 8.6. LOW POWER ENHANCED DATA RATE DQPSK MODULATION

### 8.6.1. OUTPUT POWER

<b>ID:</b>	43578	<b>Date:</b>	1/19/17
------------	-------	--------------	---------

#### LIMITS

§15.247 (b) (1)

RSS-247 (5.4) (2)

The maximum antenna gain is less than 6 dBi, therefore the limit is 30 dBm.

#### TEST PROCEDURE

The transmitter output is connected to a wideband peak and average power meter.

#### RESULTS

Channel	Frequency (MHz)	Output Power (dBm)	Limit (dBm)	Margin (dB)
Low	2402	9.73	21	-11.27
Middle	2441	9.85	21	-11.15
High	2480	9.44	22	-11.56

---

### 8.6.2. AVERAGE POWER

<b>ID:</b>	43578	<b>Date:</b>	1/19/17
------------	-------	--------------	---------

#### LIMITS

None; for reporting purposes only.

#### TEST PROCEDURE

The transmitter output is connected to a power meter.

#### RESULTS

The cable assembly insertion loss of 11 dB (including 10 dB pad and 1 dB cable) was entered as an offset in the power meter to allow for direct reading of power.

Channel	Frequency (MHz)	Average Power (dBm)
Low	2402	7.42
Middle	2441	7.35
High	2480	7.40

---

## 8.7. LOW POWER ENHANCED DATA RATE 8PSK MODULATION

### 8.7.1. 20 dB AND 99% BANDWIDTH

#### LIMITS

None; for reporting purposes only.

#### TEST PROCEDURE

The transmitter output is connected to a spectrum analyzer. The RBW is set to  $\geq 1\%$  of the 20 dB bandwidth. The VBW is set to  $\geq$  RBW. The sweep time is coupled.

#### RESULTS

Channel	Frequency (MHz)	20 dB Bandwidth (KHz)	99% Bandwidth (KHz)
Low	2402	1352	1252.6
Middle	2441	1354	1271.3
High	2480	1394	1275.6

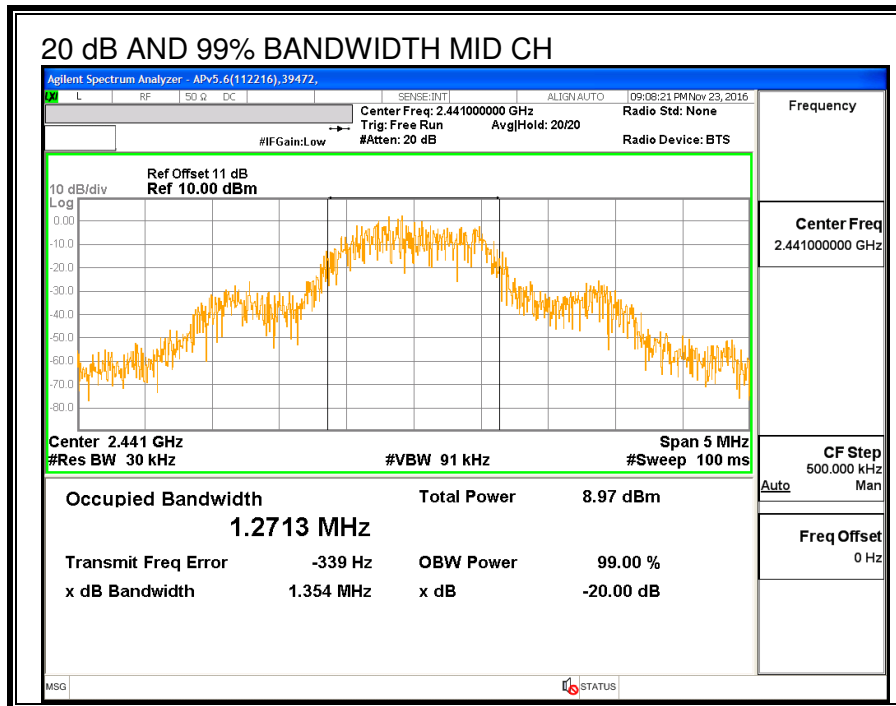
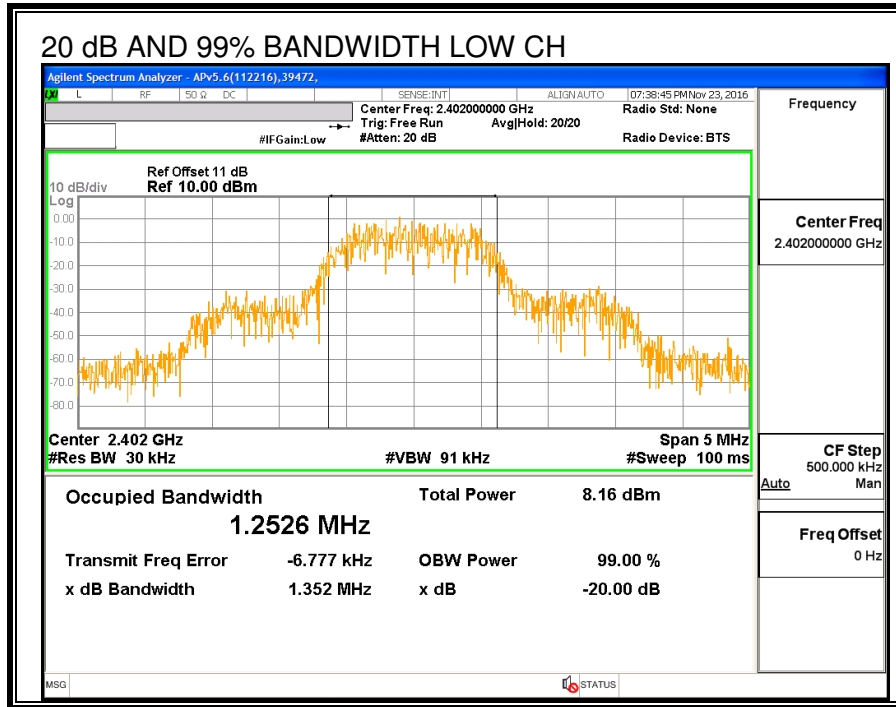

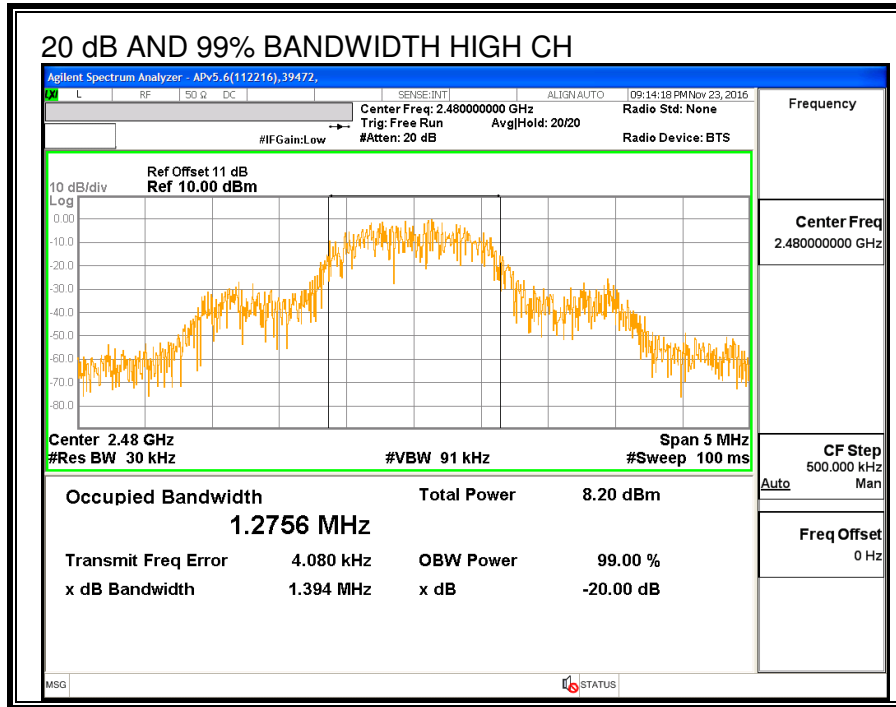



### 8.7.3. NUMBER OF HOPPING CHANNELS

#### LIMITS

FCC §15.247 (a) (1) (iii)

IC RSS-247 (5.1) (4)

Frequency hopping systems in the 2400 – 2483.5 MHz band shall use at least 15 non-overlapping channels.

#### TEST PROCEDURE

The transmitter output is connected to a spectrum analyzer. The span is set to cover the entire authorized band, in either a single sweep or in multiple contiguous sweeps. The RBW is set to a maximum of 1 % of the span. The analyzer is set to Max Hold.

#### RESULTS

Normal Mode: 79 Channels observed.

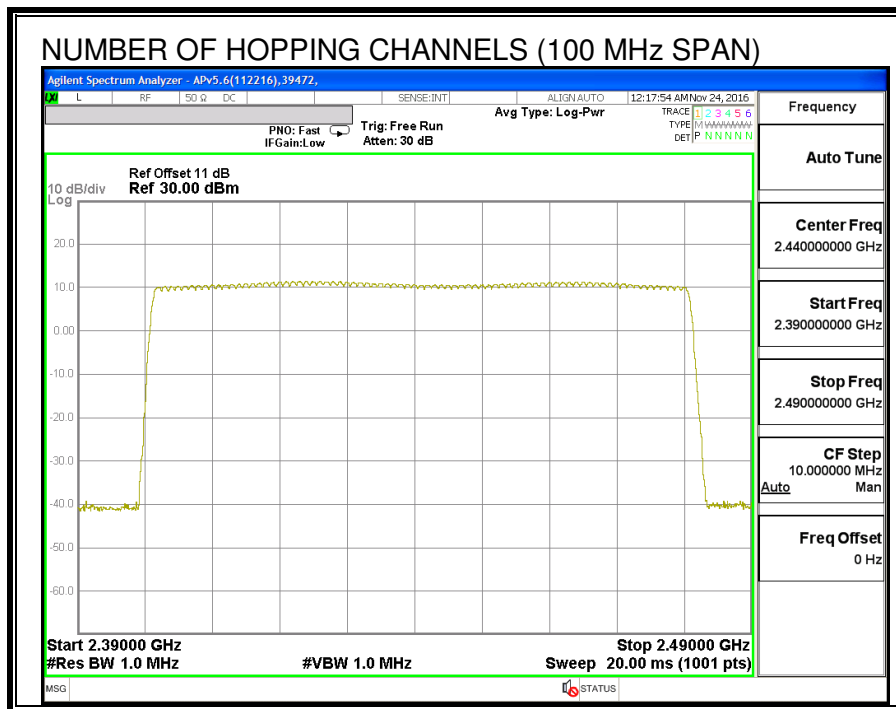

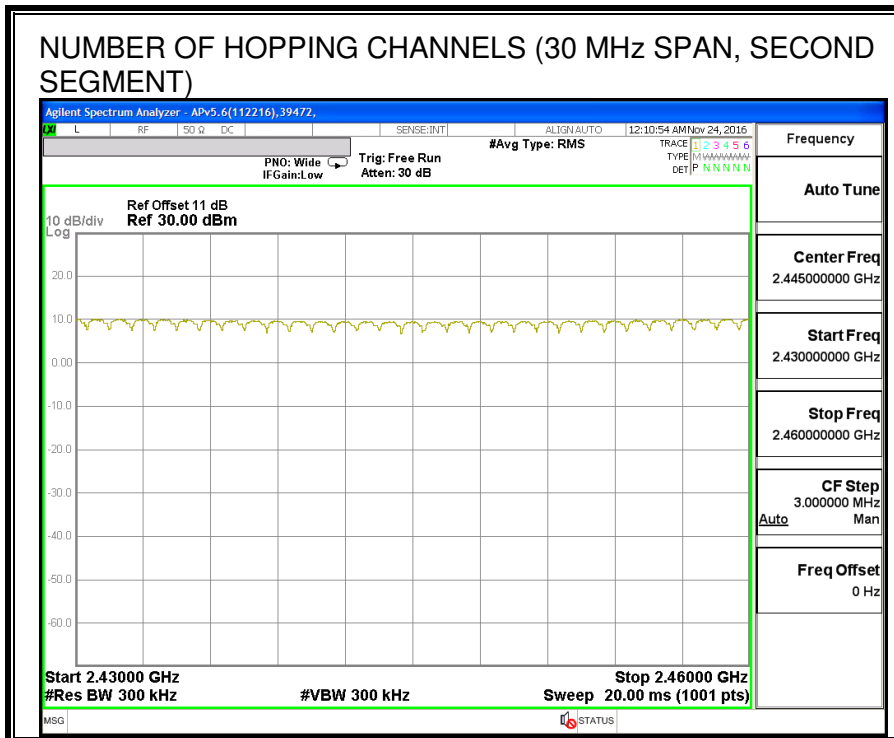
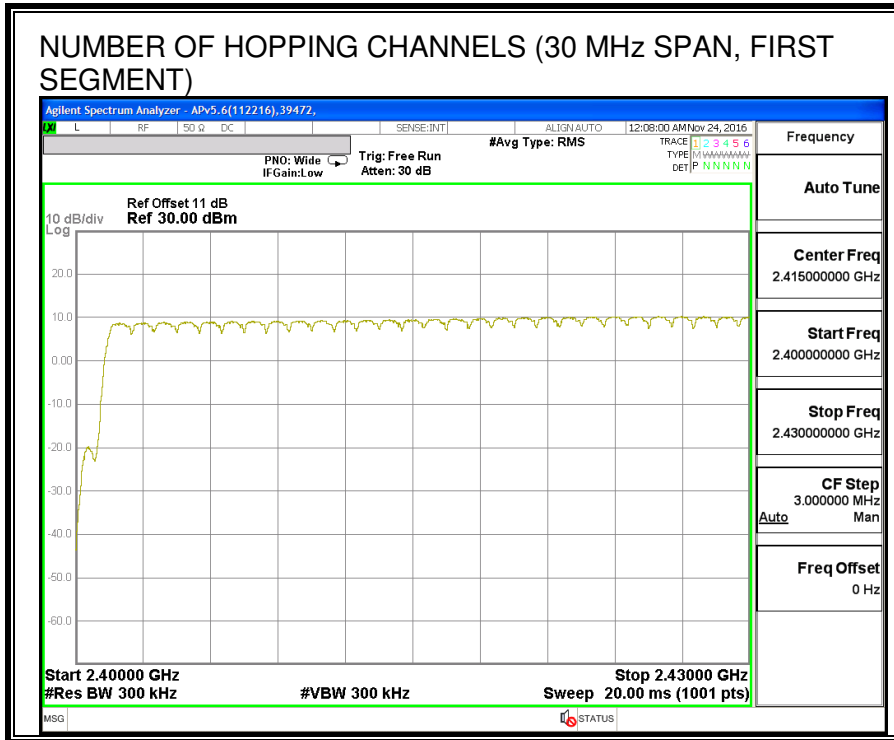

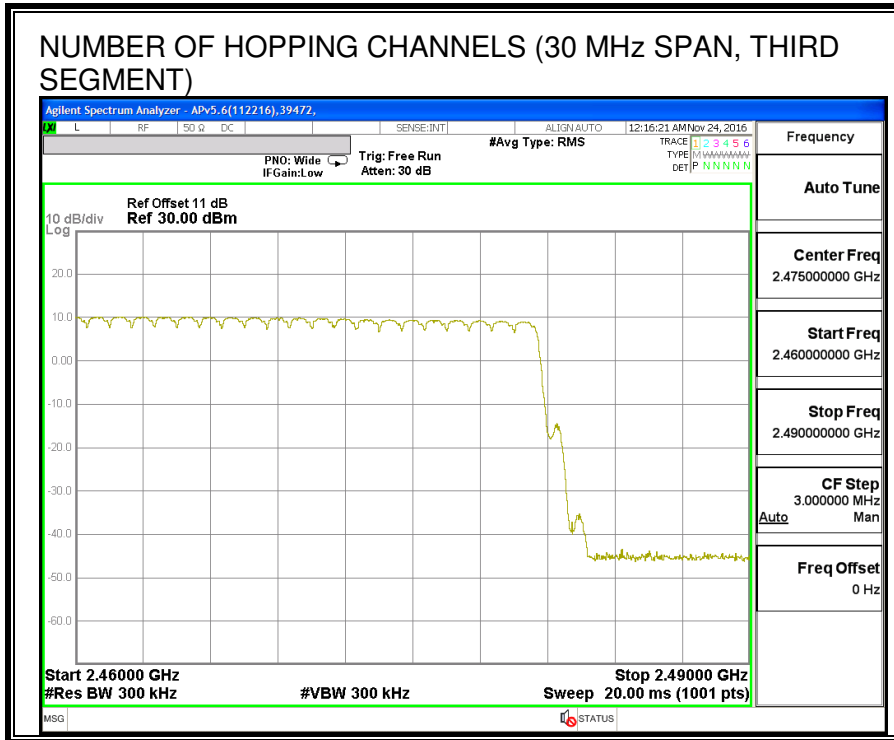

**8.7.4. AVERAGE TIME OF OCCUPANCY**

**LIMITS**

FCC §15.247 (a) (1) (iii)

IC RSS-247 (5.1) (4)

The average time of occupancy on any channel shall not be greater than 0.4 seconds within a period of 0.4 seconds multiplied by the number of hopping channels employed.

**TEST PROCEDURE**

The transmitter output is connected to a spectrum analyzer. The span is set to 0 Hz, centered on a single, selected hopping channel. The width of a single pulse is measured in a fast scan. The number of pulses is measured in a 3.16 second scan, to enable resolution of each occurrence.

The average time of occupancy in the specified 31.6 second period (79 channels \* 0.4 s) is equal to  $10 * (\# \text{ of pulses in } 3.16 \text{ s}) * \text{ pulse width}$ .

**RESULTS**

DH Packet	Pulse Width (msec)	Number of Pulses in 3.16 seconds	Average Time of Occupancy (sec)	Limit (sec)	Margin (sec)
8PSK (EDR) Mode					
3DH1	0.399	31	0.124	0.4	-0.276
3DH3	1.65	16	0.264	0.4	-0.136
3DH5	2.896	9	0.261	0.4	-0.139

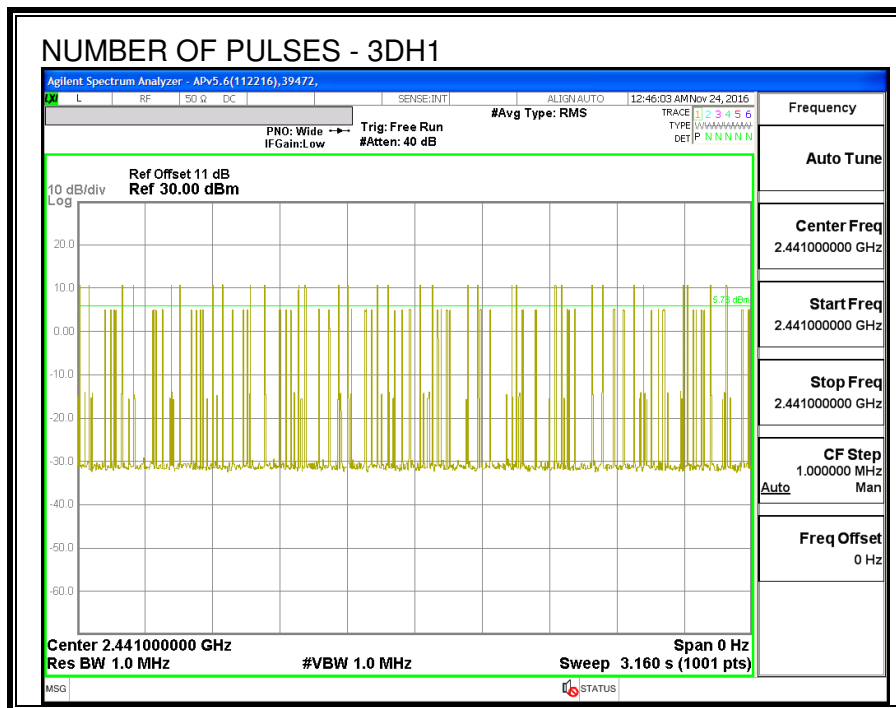
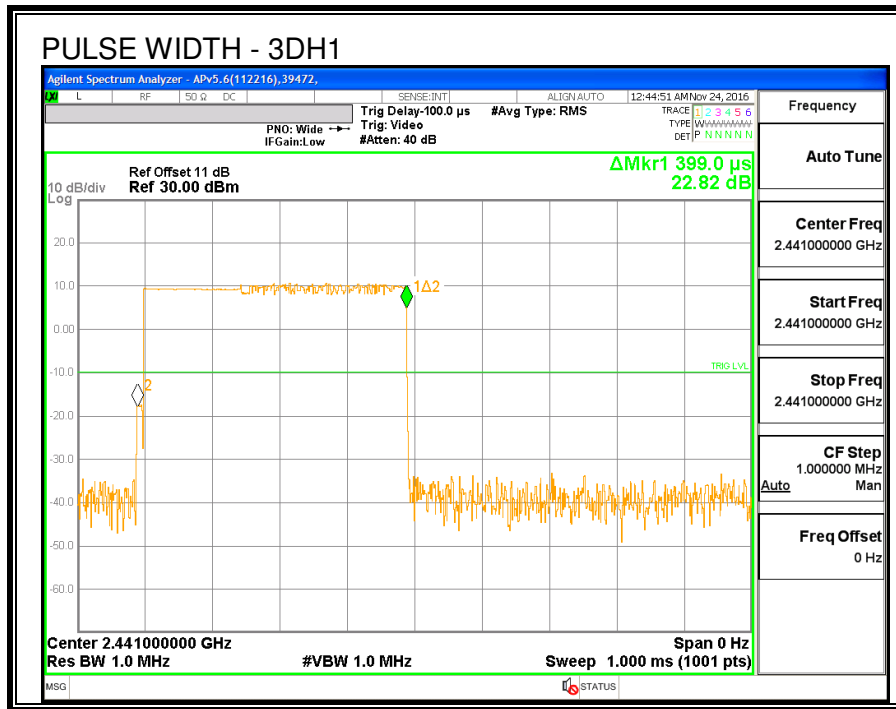

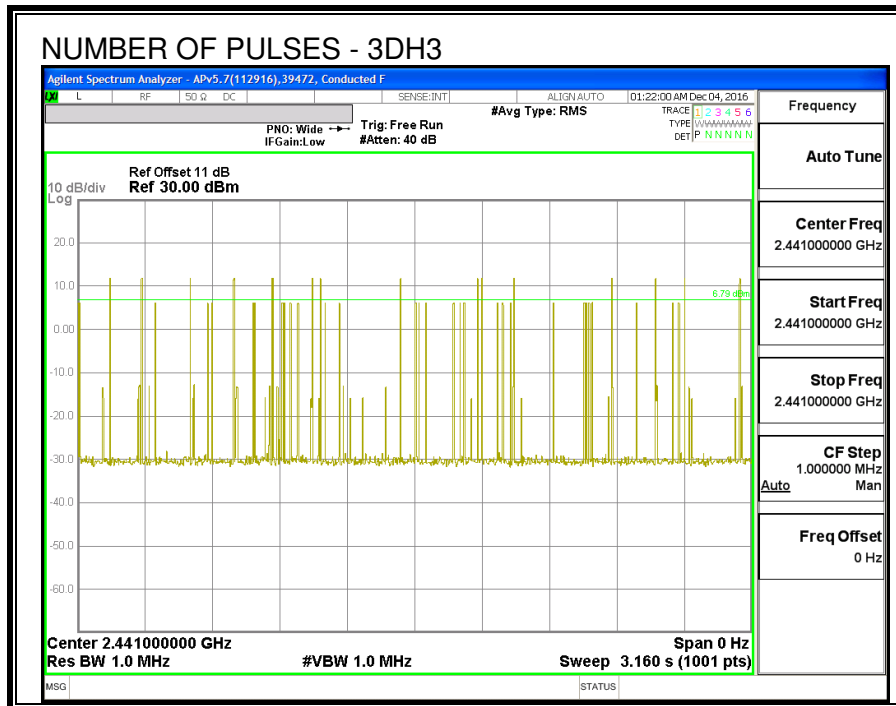
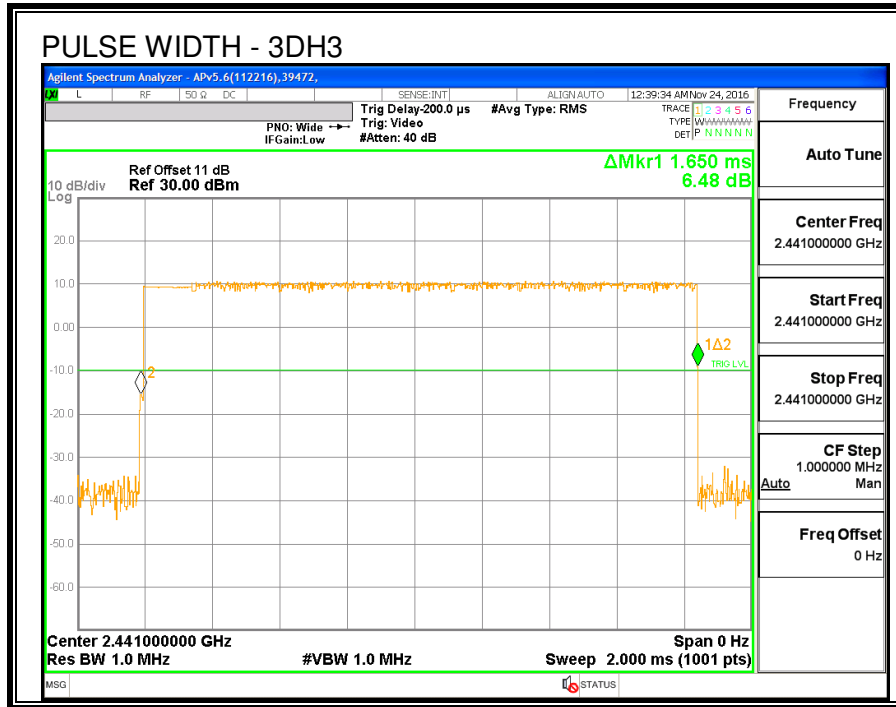

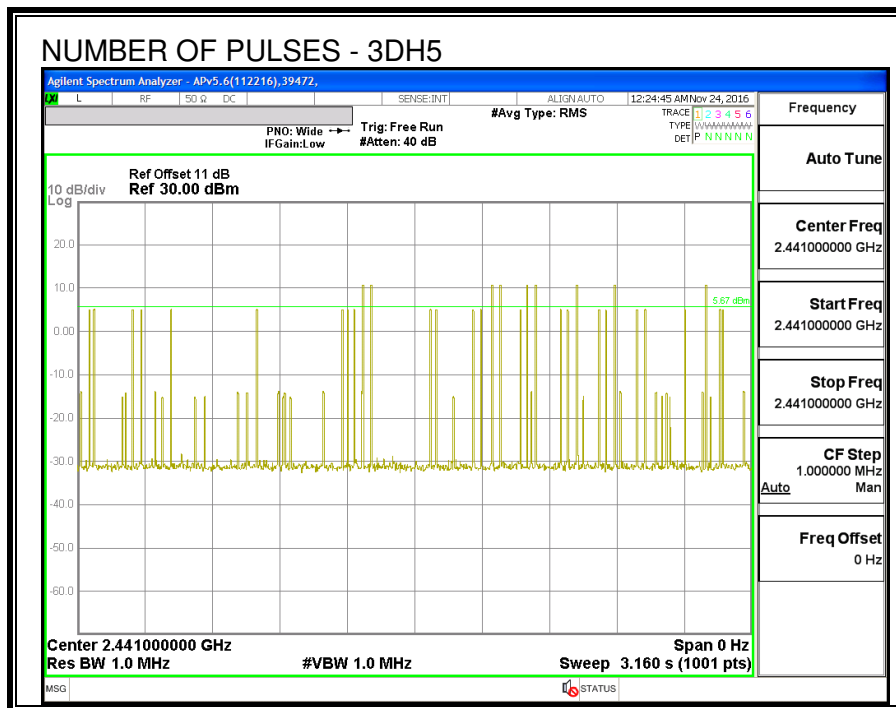

### 8.7.5. OUTPUT POWER

<b>ID:</b>	43578	<b>Date:</b>	1/19/17
------------	-------	--------------	---------

#### LIMITS

§15.247 (b) (1)

RSS-247 (5.4) (2)

The maximum antenna gain is less than 6 dBi, therefore the limit is 30 dBm.

#### TEST PROCEDURE

The transmitter output is connected to a wideband peak and average power meter.

#### RESULTS

Channel	Frequency (MHz)	Output Power (dBm)	Limit (dBm)	Margin (dB)
Low	2402	9.77	21	-11.23
Middle	2441	9.98	21	-11.02
High	2480	9.53	21	-11.47

---

### 8.7.6. AVERAGE POWER

<b>ID:</b>	43578	<b>Date:</b>	1/19/17
------------	-------	--------------	---------

#### LIMITS

None; for reporting purposes only.

#### TEST PROCEDURE

The transmitter output is connected to a power meter.

#### RESULTS

The cable assembly insertion loss of 11 dB (including 10 dB pad and 1 dB cable) was entered as an offset in the power meter to allow for direct reading of power.

Channel	Frequency (MHz)	Average Power (dBm)
Low	2402	7.49
Middle	2441	7.40
High	2480	7.47

### 8.7.7. CONDUCTED BANDEDGE AND SPURIOUS EMISSIONS

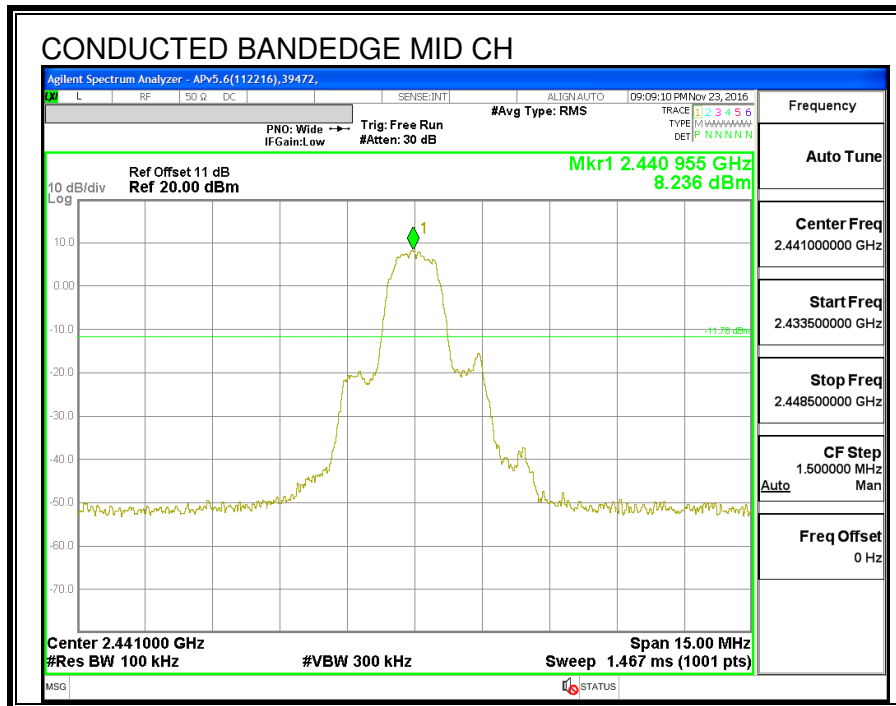
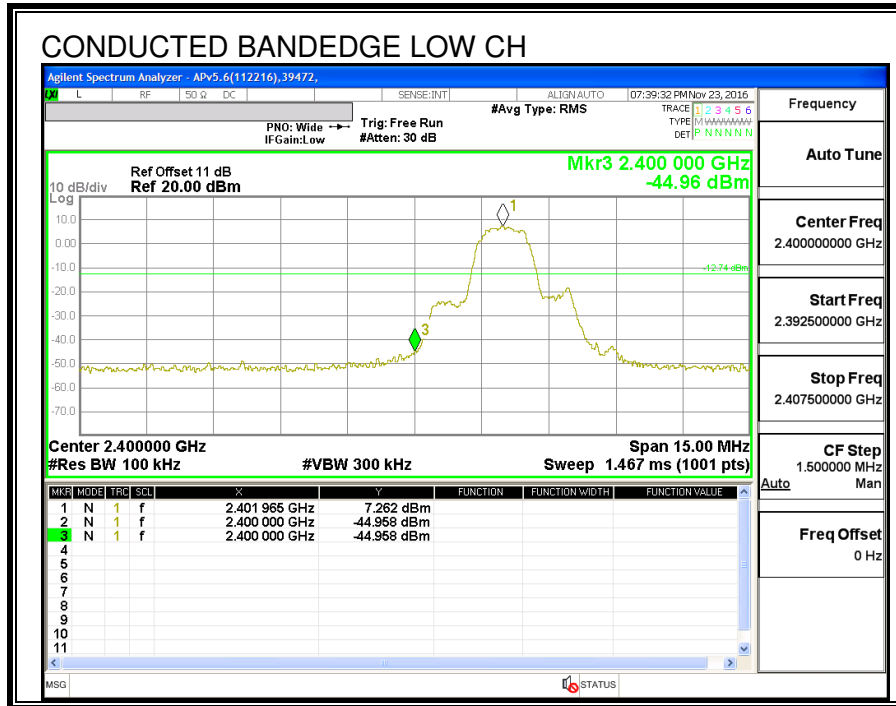

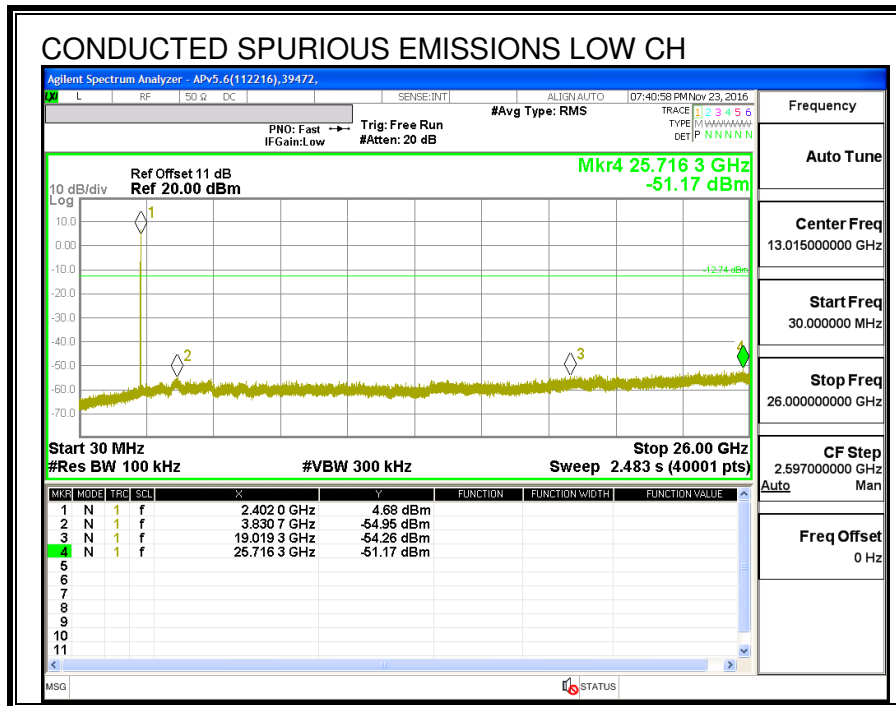
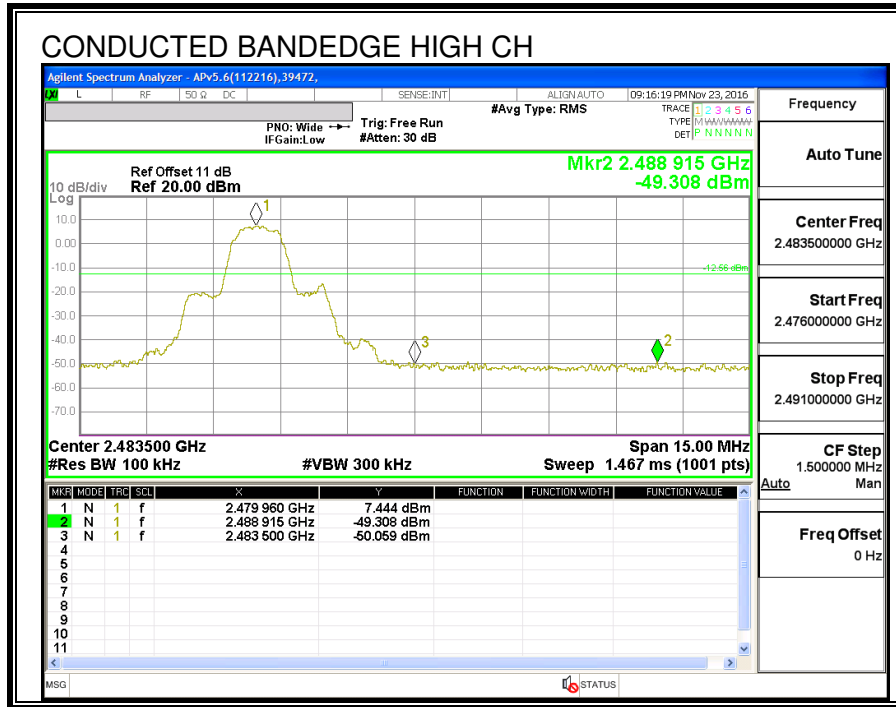

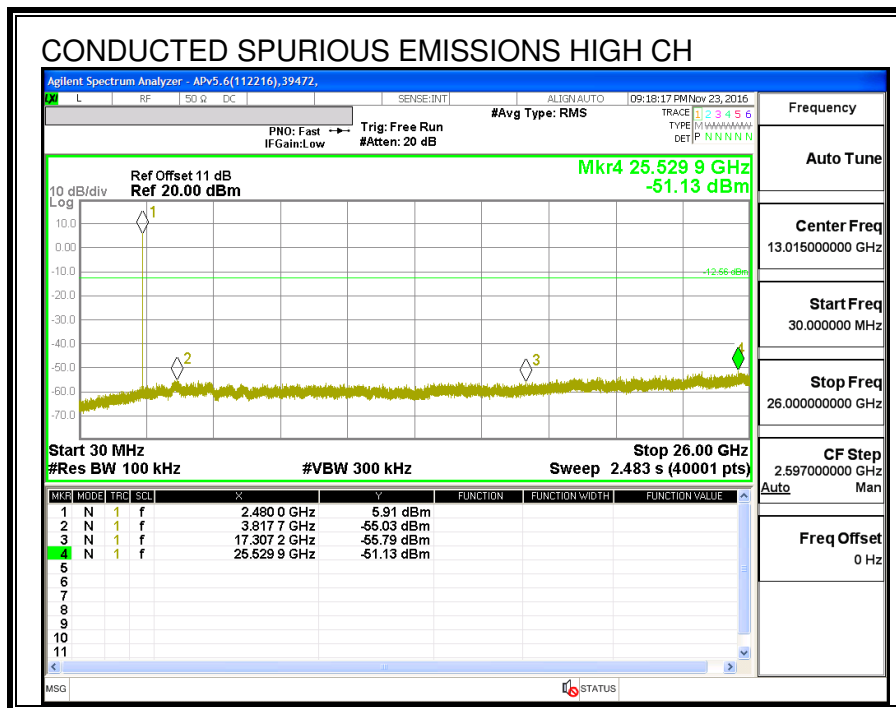
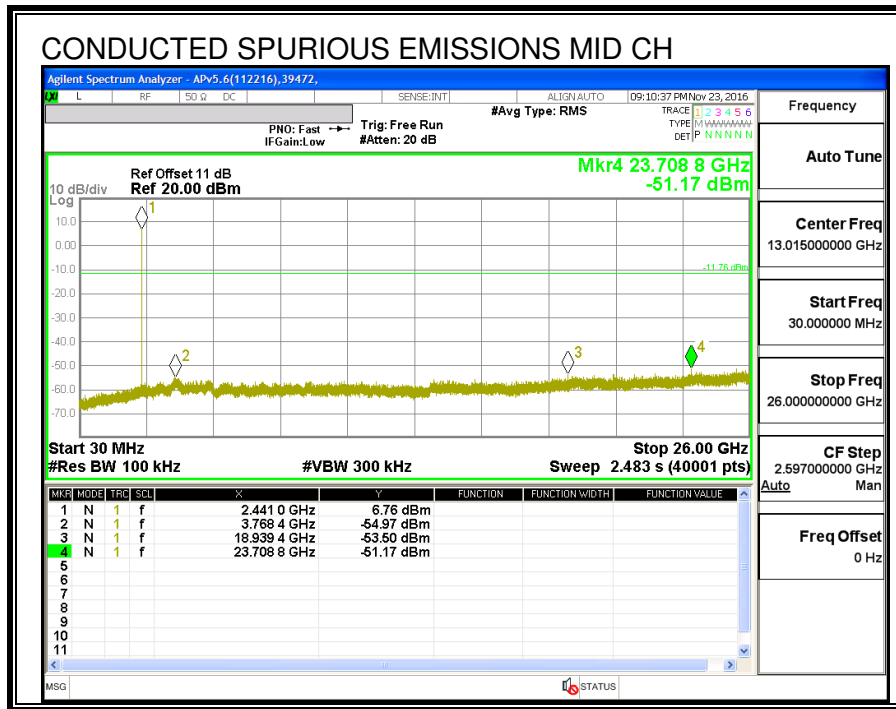

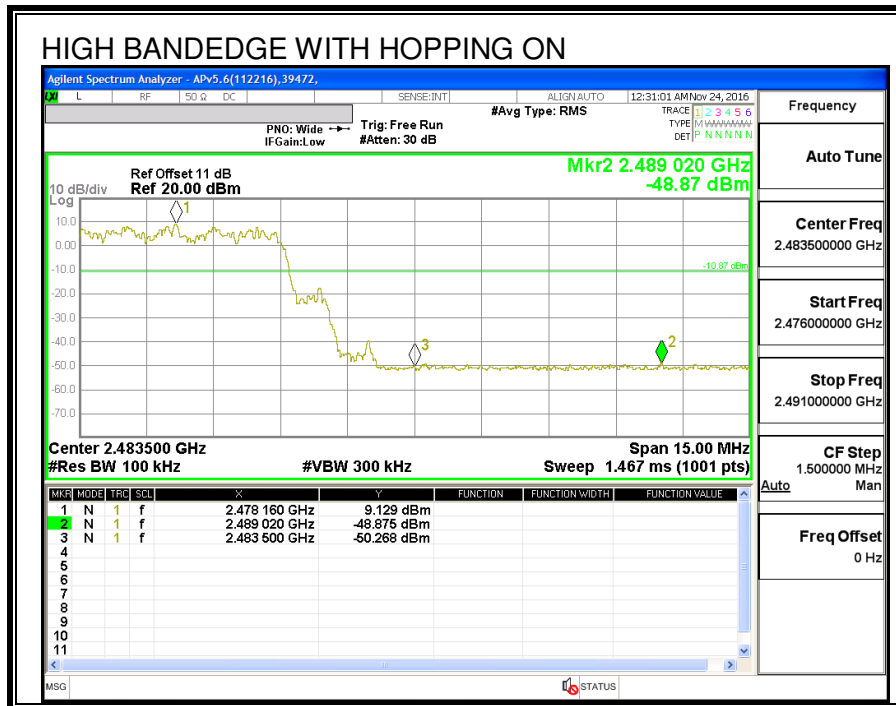
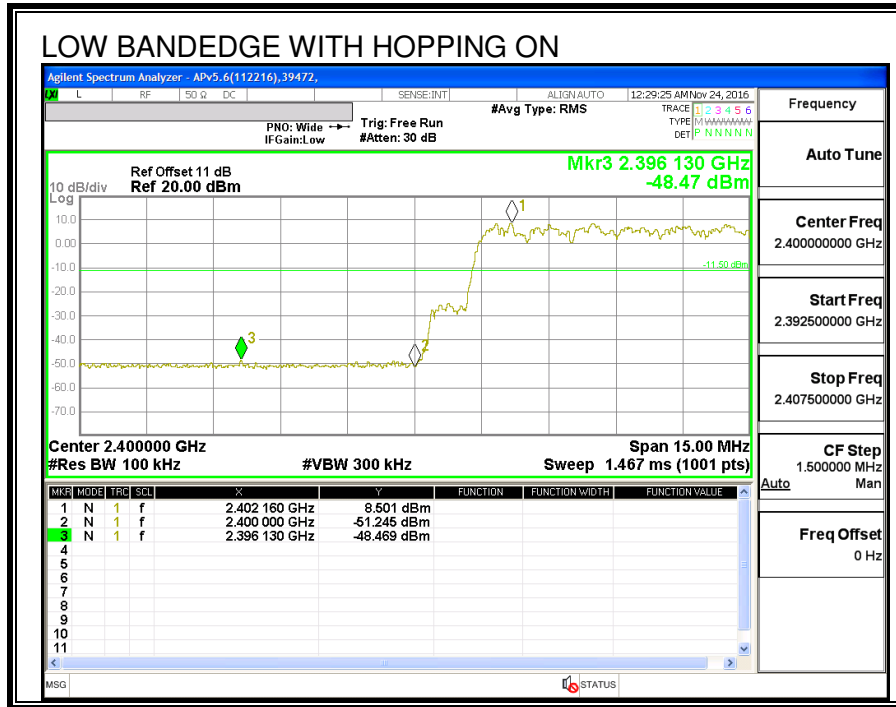

## 9. RADIATED TEST RESULTS

### 9.1. LIMITS AND PROCEDURE

#### LIMITS

FCC §15.205 and §15.209.

IC RSS-GEN, Section 8.9 and 8.10.

Frequency Range (MHz)	Field Strength Limit (uV/m) at 3 m	Field Strength Limit (dBuV/m) at 3 m
30 - 88	100	40
88 - 216	150	43.5
216 - 960	200	46
Above 960	500	54

#### TEST PROCEDURE

The EUT is placed on a non-conducting table 80 cm above the ground plane for measurement below 1GHz; 1.5 m above the ground plane for measurement above 1GHz. The antenna to EUT distance is 3 meters. The EUT is configured in accordance with ANSI C63.10. The EUT is set to transmit in a continuous mode.

For measurements below 1 GHz the resolution bandwidth is set to 100 kHz for peak detection measurements or 120 kHz for quasi-peak detection measurements. Peak detection is used unless otherwise noted as quasi-peak.

For pre-scans above 1 GHz the resolution bandwidth is set to 1 MHz; the video bandwidth is set to 30 KHz for peak measurements.

For final scans above 1 GHz the resolution bandwidth is set to 1 MHz, then the video bandwidth is set to 3 MHz for peak measurements and 1 MHz resolution bandwidth with 1/T (10 Hz) video bandwidth with peak detector for average measurements.

PKFH - FHSS: RB=100k/1MHz VB=3 x RB, Peak→ this is a note from Radiated automation software. When the frequency is below 1G, software is using RB=100kHz; when the frequency is above 1G, software is using RB=1MHz.

The frequency range of interest is monitored at a fixed antenna height and EUT azimuth. The EUT is rotated through 360 degrees to maximize emissions received. The antenna is scanned from 1 to 4 meters above the ground plane to further maximize the emission. Measurements are made with the antenna polarized in both the vertical and the horizontal positions.

#### RESULTS

## 9.2. HIGH POWER BASIC DATA RATE GFSK MODULATION

### 9.2.1. RESTRICTED BANDEDGE (LOW CHANNEL)

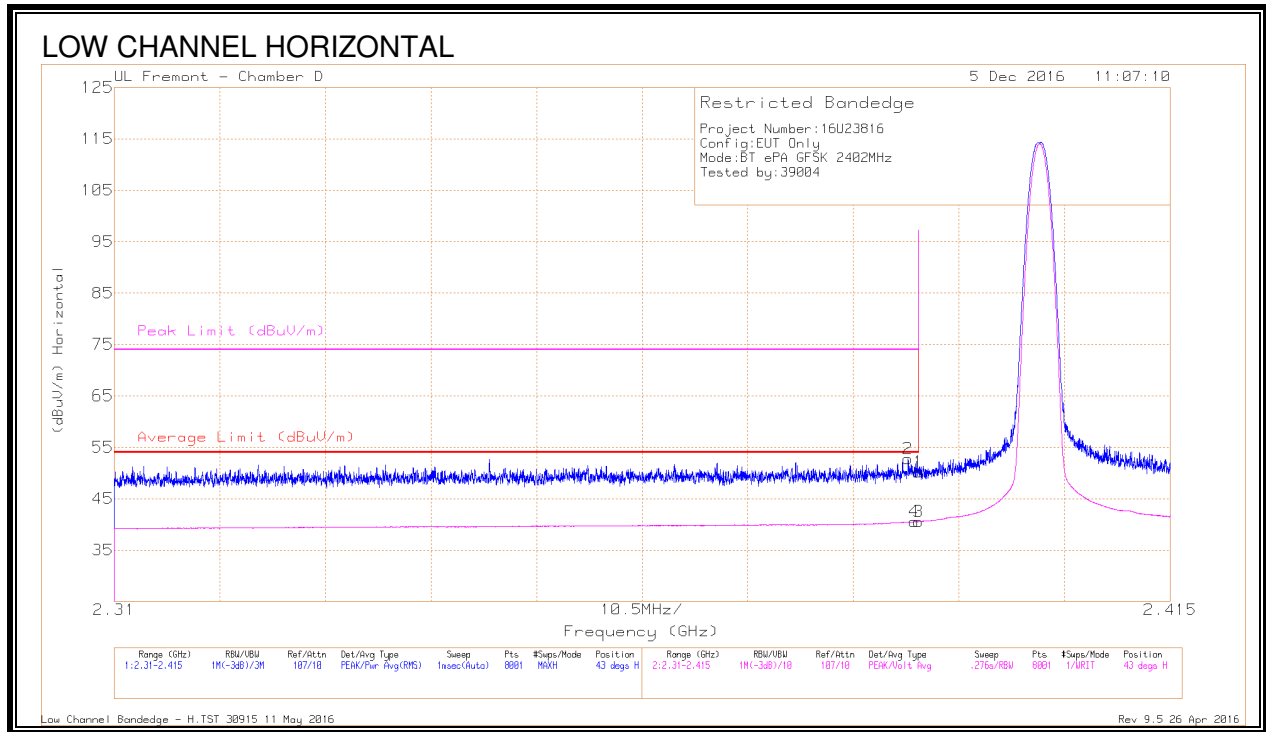

#### Trace Markers

Marker	Frequency (GHz)	Meter Reading (dBuV)	Det	AF T712 (dB/m)	Amp/Cb/FI tr/Pad (dB)	Corrected Reading (dBuV/m)	Average Limit (dBuV/m)	Margin (dB)	Peak Limit (dBuV/m)	PK Margin (dB)	Azimuth (Degs)	Height (cm)	Polarity
1	* 2.39	38.77	Pk	32.1	-20.7	50.17	-	-	74	-23.83	43	226	H
2	* 2.389	41.47	Pk	32.1	-20.8	52.77	-	-	74	-21.23	43	226	H
3	* 2.39	29.14	VA1T	32.1	-20.7	40.54	54	-13.46	-	-	43	226	H
4	* 2.39	29.24	VA1T	32.1	-20.8	40.54	54	-13.46	-	-	43	226	H

\* - indicates frequency in CFR47 Pt 15 / IC RSS-Restricted Band

Pk - Peak detector

VA1T - FHSS: Linear Voltage Average VB=1/Ton where: Ton is transmit duration

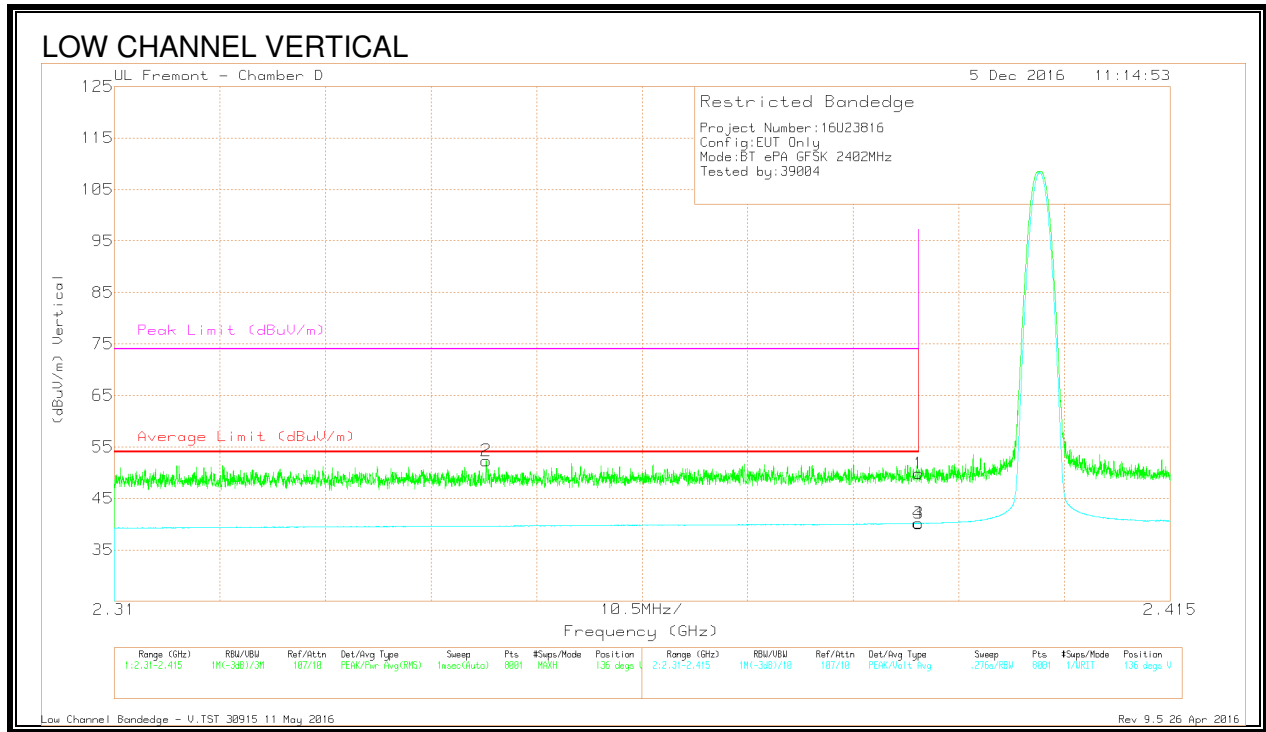

Trace Markers

Marker	Frequency (GHz)	Meter Reading (dBuV)	Det	AF T712 (dB/m)	Amp/C bl/Filtr/ Pad (dB)	Corrected Reading (dBuV/m)	Average Limit (dBuV/m)	Margin (dB)	Peak Limit (dBuV/m)	PK Margin (dB)	Azimuth (Degs)	Height (cm)	Polarity
1	* 2.39	38.44	Pk	32.1	-20.7	49.84	-	-	74	-24.16	136	148	V
2	* 2.347	41.43	Pk	31.8	-20.9	52.33	-	-	74	-21.67	136	148	V
3	* 2.39	28.74	VA1T	32.1	-20.7	40.14	54	-13.86	-	-	136	148	V
4	* 2.39	28.76	VA1T	32.1	-20.7	40.16	54	-13.84	-	-	136	148	V

\* - indicates frequency in CFR47 Pt 15 / IC RSS-Restricted Band

Pk - Peak detector

VA1T - FHSS: Linear Voltage Average VB=1/Ton where: Ton is transmit duration

**9.2.2. AUTHORIZED BANDEGE (HIGH CHANNEL)**

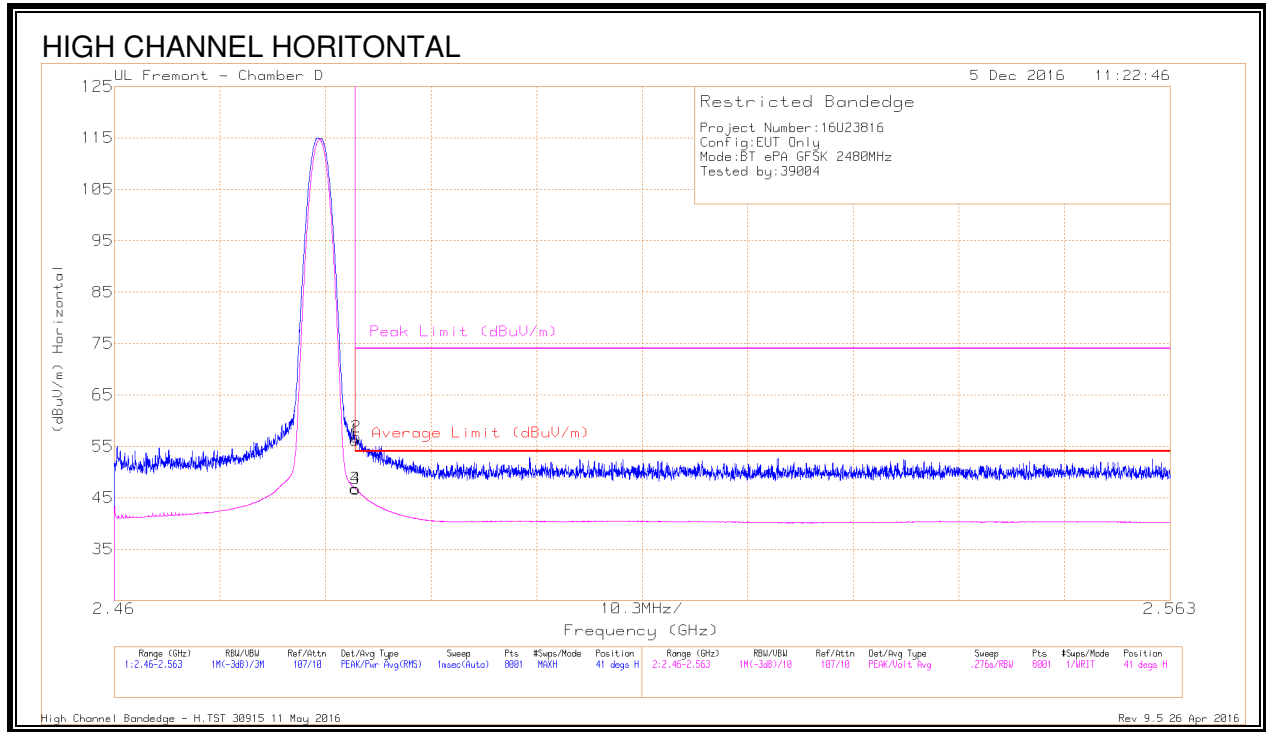

Trace Markers

Marker	Frequency (GHz)	Meter Reading (dBuV)	Det	AF T712 (dB/m)	Amp/Cbl/Filtr/Pad (dB)	Corrected Reading (dBuV/m)	Average Limit (dBuV/m)	Margin (dB)	Peak Limit (dBuV/m)	PK Margin (dB)	Azimuth (Degs)	Height (cm)	Polarity
1	* 2.484	44.71	Pk	32.3	-20.8	56.21	-	-	74	-17.79	41	106	H
2	* 2.484	45.31	Pk	32.3	-20.8	56.81	-	-	74	-17.19	41	106	H
3	* 2.484	35.28	VA1T	32.3	-20.8	46.78	54	-7.22	-	-	41	105	H
4	* 2.484	35.22	VA1T	32.3	-20.8	46.72	54	-7.28	-	-	41	105	H

\* - indicates frequency in CFR47 Pt 15 / IC RSS-Restricted Band

Pk - Peak detector

VA1T - FHSS: Linear Voltage Average  $VB=1/Ton$  where:  $Ton$  is transmit duration

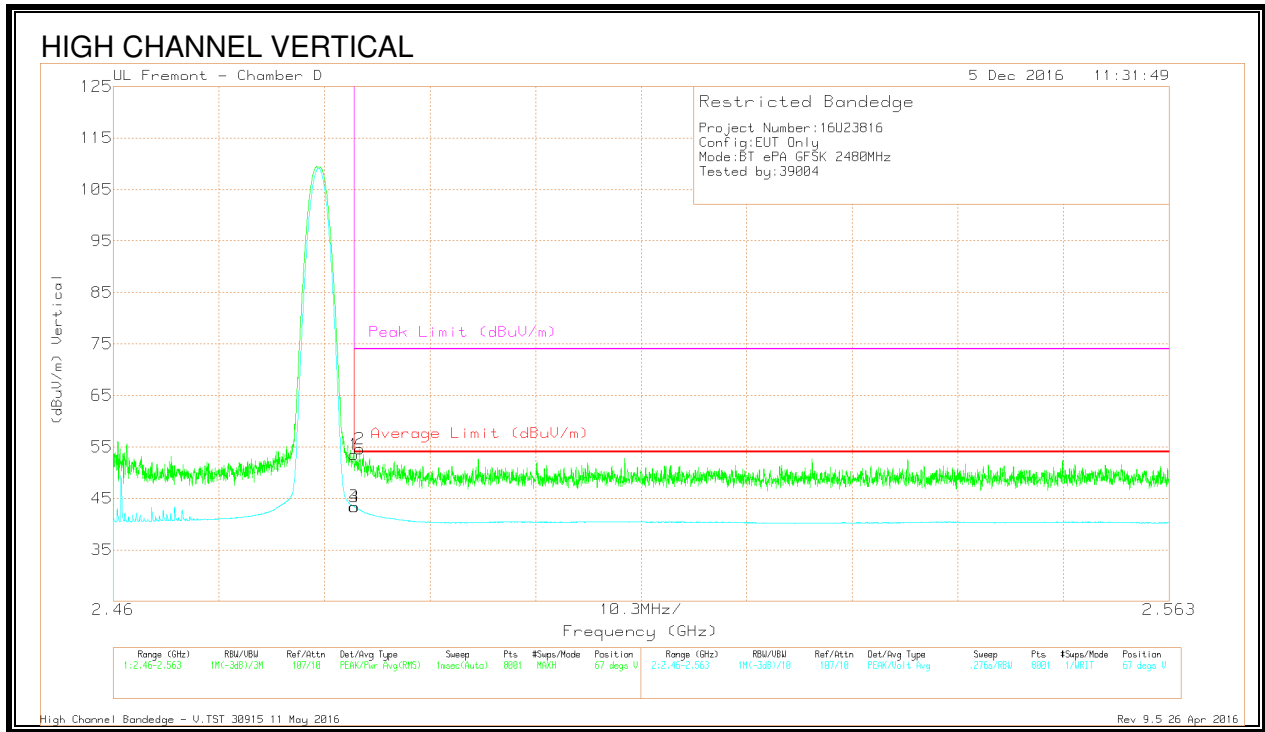

Trace Markers

Marker	Frequency (GHz)	Meter Reading (dBuV)	Det	AF T712 (dB/m)	Amp/Cbl/Filtr/Pad (dB)	Corrected Reading (dBuV/m)	Average Limit (dBuV/m)	Margin (dB)	Peak Limit (dBuV/m)	PK Margin (dB)	Azimuth (Degs)	Height (cm)	Polarity
1	* 2.484	42	Pk	32.3	-20.8	53.5	-	-	74	-20.5	67	158	V
2	* 2.484	43.11	Pk	32.3	-20.8	54.61	-	-	74	-19.39	67	158	V
3	* 2.484	31.88	VA1T	32.3	-20.8	43.38	54	-10.62	-	-	67	158	V
4	* 2.484	31.83	VA1T	32.3	-20.8	43.33	54	-10.67	-	-	67	158	V

\* - indicates frequency in CFR47 Pt 15 / IC RSS-Restricted Band

Pk - Peak detector

VA1T - FHSS: Linear Voltage Average  $VB=1/Ton$  where: Ton is transmit duration

### 9.2.3. HARMONICS AND SPURIOUS EMISSIONS

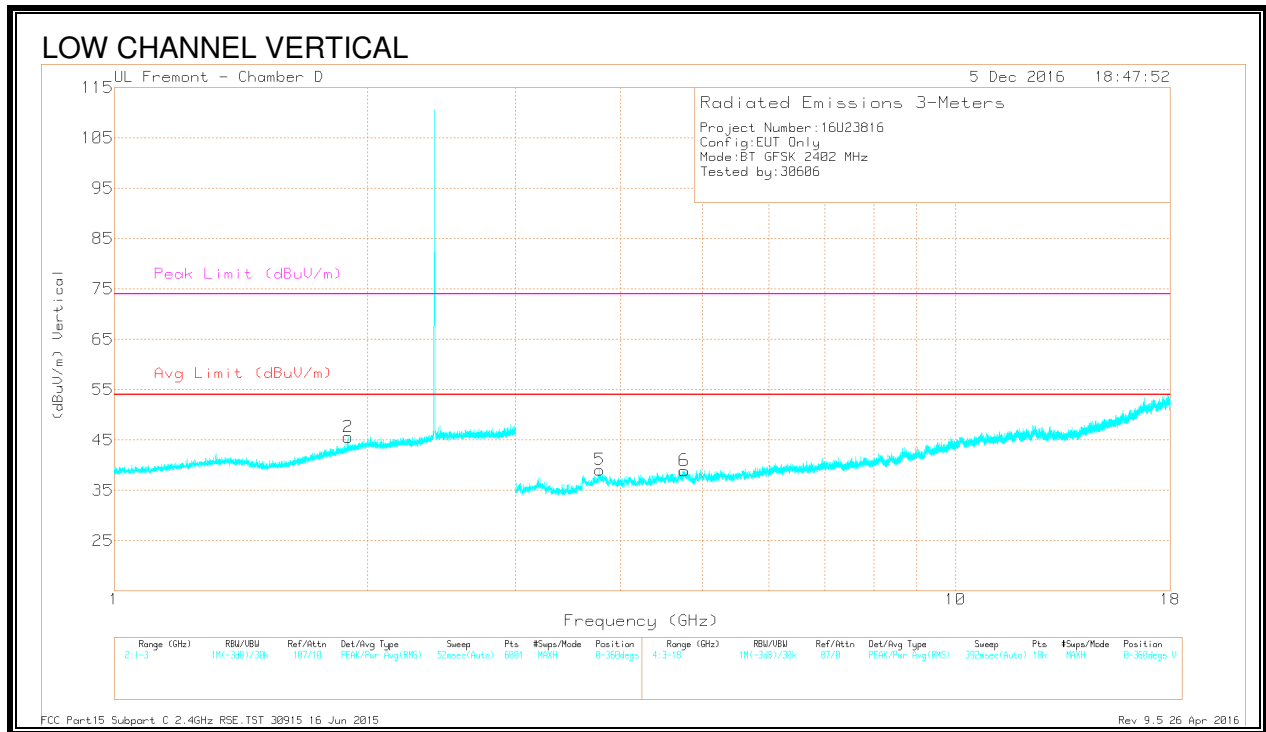
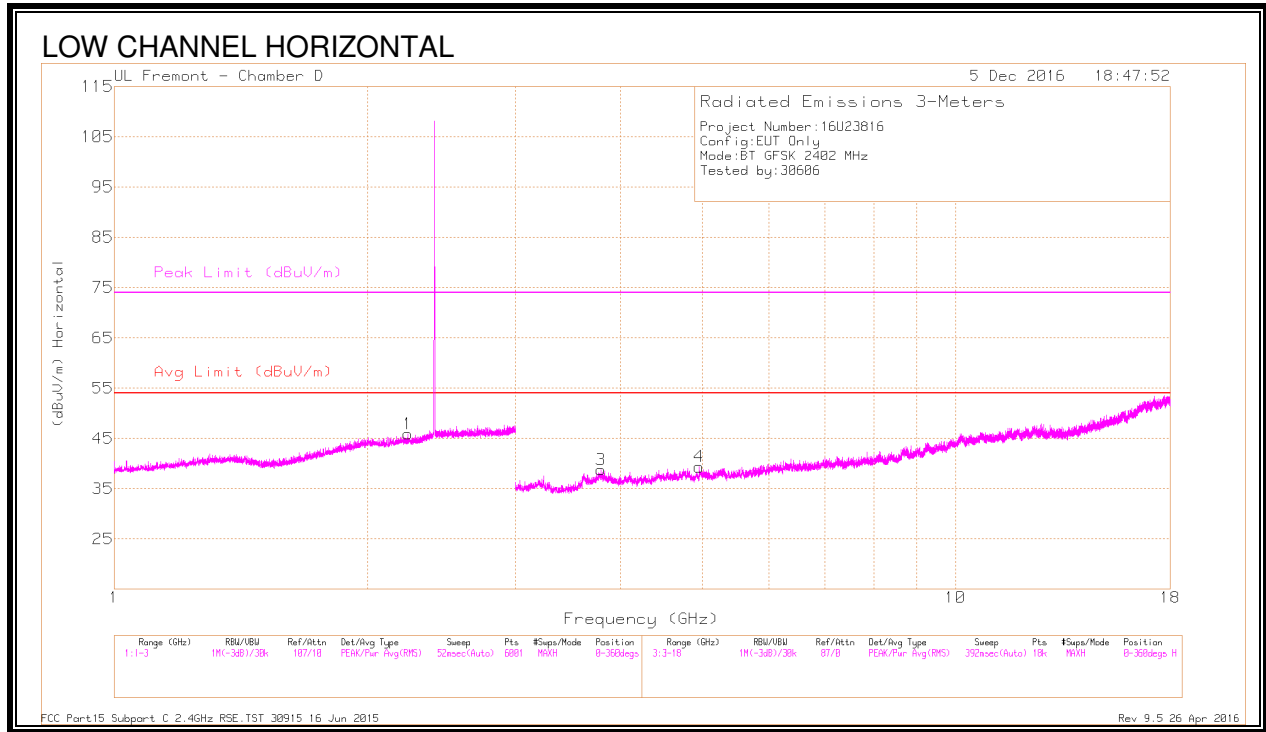

Marker	Frequency (GHz)	Meter Reading (dBuV)	Det	AF T712 (dB/m)	Amp/Cbl/FI tr/Pad (dB)	Corrected Reading (dBuV/m)	Avg Limit (dBuV/m)	Margin (dB)	Peak Limit (dBuV/m)	PK Margin (dB)	Azimuth (Degs)	Height (cm)	Polarity
1	* 2.234	40.25	PKFH	31.5	-20.9	50.85	-	-	74	-23.15	244	346	H
	* 2.237	29.01	VA1T	31.5	-20.9	39.61	54	-14.39	-	-	244	346	H
3	* 3.793	38.92	PKFH	33.5	-28.3	44.12	-	-	74	-29.88	245	142	H
	* 3.791	27.4	VA1T	33.5	-28.3	32.6	54	-21.4	-	-	245	142	H
4	* 4.961	38.22	PKFH	34.1	-27.4	44.92	-	-	74	-29.08	146	305	H
	* 4.962	26.36	VA1T	34.1	-27.4	33.06	54	-20.94	-	-	146	305	H
5	* 3.776	38.92	PKFH	33.5	-28.1	44.32	-	-	74	-29.68	320	254	V
	* 3.778	27.46	VA1T	33.5	-28	32.96	54	-21.04	-	-	320	254	V
6	* 4.762	37.68	PKFH	34	-26.5	45.18	-	-	74	-28.82	77	170	V
	* 4.762	26	VA1T	34	-26.5	33.5	54	-20.5	-	-	77	170	V
2	1.9	40.16	PKFH	30.8	-21.4	49.56	-	-	-	-	193	129	V

\* - indicates frequency in CFR47 Pt 15 / IC RSS-Restricted Band

PKFH - FHSS: RB=100k/1MHz VB=3 x RB, Peak

VA1T - FHSS: Linear Voltage Average VB=1/Ton where: Ton is transmit duration