



# **CERTIFICATION TEST REPORT**

**Report Number. :** 16U23816-E6V2

**Applicant :** APPLE, INC  
1 INFINITE LOOP  
CUPERTINO, CA 95014, U.S.A.

**Model :** A1671, A1821

**FCC ID :** BCGA1671

**IC :** 579-A1671

**EUT :** TABLET DEVICE  
**Description**

**Test Standard(s) :** FCC CFR47 PART 22H, 24E, 27L, AND 90S IC RSS-132 ISSUE 3,  
RSS-133 ISSUE 6 AND RSS-139 ISSUE 3

**Date Of Issue:**  
February 28, 2017

**Prepared by:**  
UL Verification Services Inc.  
47173 Benicia Street  
Fremont, CA 94538, U.S.A.  
TEL: (510) 771-1000  
FAX: (510) 661-0888



Revision History

<u>Rev.</u>	<u>Issue Date</u>	<u>Revisions</u>	<u>Revised By</u>
V1	02/21/2017	Initial Issue	Chin Pang
V2	02/28/2017	Addressed TCB Questions	Francisco Guarnero

## TABLE OF CONTENTS

<b>1. ATTESTATION OF TEST RESULTS .....</b>	<b>5</b>
<b>2. TEST METHODOLOGY .....</b>	<b>6</b>
<b>3. FACILITIES AND ACCREDITATION .....</b>	<b>6</b>
<b>4. CALIBRATION AND UNCERTAINTY .....</b>	<b>6</b>
4.1. MEASURING INSTRUMENT CALIBRATION .....	6
4.2. SAMPLE CALCULATION .....	7
4.3. MEASUREMENT UNCERTAINTY.....	7
<b>5. EQUIPMENT UNDER TEST .....</b>	<b>8</b>
5.1. DESCRIPTION OF EUT .....	8
5.2. DESCRIPTION OF MODELS DIFFERENCES.....	8
5.3. MAXIMUM OUTPUT POWER.....	8
5.3.1. ANTENNA C .....	9
5.3.2. ANTENNA D .....	11
5.4. DESCRIPTION OF AVAILABLE ANTENNAS .....	13
5.5. SOFTWARE AND FIRMWARE.....	13
5.6. WORST-CASE CONFIGURATION AND MODE.....	13
5.7. DESCRIPTION OF TEST SETUP.....	14
<b>6. TEST AND MEASUREMENT EQUIPMENT .....</b>	<b>16</b>
<b>7. RF POWER OUTPUT VERIFICATION .....</b>	<b>17</b>
7.1. GSM.....	17
7.1.1. GPRS/EGPRS .....	19
7.2. CDMA200.....	20
7.2.1. CDMA2000 1xRTT.....	20
7.2.2. 1xEV-DO - Release 0 (REL 0) .....	27
7.2.3. 1xEV-DO - Revision A (REV A) .....	30
7.3. UMTS .....	33
7.3.1. UMTS REL99.....	33
7.3.2. HSDPA REL 5 .....	35
7.3.3. HSPA REL 6 (HSDPA & HSUPA) .....	38
7.3.4. DUAL CARRIER HSDPA.....	43
<b>8. CONDUCTED TEST RESULTS .....</b>	<b>47</b>
8.1. OCCUPIED BANDWIDTH .....	47
8.1.1. GSM GPRS .....	50
8.1.2. GSM EGPRS .....	51

8.1.3.	CDMA2000 1xRTT.....	52
8.1.4.	CDMA2000 EVDO REV A.....	54
8.1.5.	UMTS Rel99.....	56
8.1.6.	UMTS HSDPA.....	58
8.2.	<b>BAND EDGE.....</b>	<b>60</b>
8.2.1.	GSM GPRS.....	62
8.2.2.	GSM EGPRS.....	64
8.2.3.	CDMA2000 1xRTT.....	66
8.2.4.	CDMA2000 1xRTT BC10 MASK.....	69
8.2.5.	CDMA2000 EVDO REV A.....	71
8.2.6.	CDMA2000 EVDO REV A BC10 MASK.....	74
8.2.7.	UMTS Rel99.....	76
8.2.8.	UMTS HSDPA.....	79
8.3.	<b>OUT OF BAND EMISSIONS.....</b>	<b>82</b>
8.3.1.	GSM GPRS.....	84
8.3.2.	GSM EGPRS.....	85
8.3.3.	CDMA2000 1xRTT.....	86
8.3.4.	CDMA2000 EVDO REV A.....	87
8.3.5.	UMTS Rel99.....	89
8.3.6.	UMTS HSDPA.....	90
<b>9.</b>	<b>FREQUENCY STABILITY.....</b>	<b>92</b>
9.1.	GSM.....	94
9.2.	CDMA2000.....	96
9.3.	UMTS.....	98
<b>10.</b>	<b>PEAK-TO-AVERAGE RATIO.....</b>	<b>100</b>
<b>11.</b>	<b>RADIATED TEST RESULTS.....</b>	<b>109</b>
11.1.	<b>FIELD STRENGTH OF SPURIOUS RADIATION (ANTENNA C).....</b>	<b>109</b>
11.1.1.	GSM.....	111
11.1.2.	CDMA2000.....	115
11.1.3.	UMTS.....	121
11.2.	<b>FIELD STRENGTH OF SPURIOUS RADIATION (ANTENNA D).....</b>	<b>127</b>
11.2.1.	GSM.....	127
11.2.2.	CDMA2000.....	131
11.2.3.	UMTS.....	137
<b>12.</b>	<b>SETUP PHOTOS.....</b>	<b>143</b>

# 1. ATTESTATION OF TEST RESULTS

**COMPANY NAME:** APPLE  
1 INFINITE LOOP  
CUPERTINO, CA 95014, U.S.A.

**EUT DESCRIPTION:** TABLET DEVICE

**MODEL:** A1671, A1821

**SERIAL NUMBER:** DLX645701 (CONDUCTED); DLXST00NHPJQ (RADIATED)

**DATE TESTED:** NOVEMBER 18, 2016 – FEBRUARY 04, 2017

APPLICABLE STANDARDS	
STANDARD	TEST RESULTS
CFR 47 Part 22H, 24E, 27L, AND 90S	Pass
IC RSS-132 ISSUE 3, RSS-133 ISSUE 6, AND RSS-139 ISSUE 3	Pass

UL Verification Services Inc. tested the above equipment in accordance with the requirements set forth in the above standards. All indications of Pass/Fail in this report are opinions expressed by UL Verification Services Inc. based on interpretations and/or observations of test results. Measurement Uncertainties were not taken into account and are published for informational purposes only. The test results show that the equipment tested is capable of demonstrating compliance with the requirements as documented in this report.

**Note:** The results documented in this report apply only to the tested sample, under the conditions and modes of operation as described herein. This document may not be altered or revised in any way unless done so by UL Verification Services Inc. and all revisions are duly noted in the revisions section. Any alteration of this document not carried out by UL Verification Services Inc. will constitute fraud and shall nullify the document. This report must not be used by the client to claim product certification, approval, or endorsement by NVLAP, NIST, any agency of the Federal Government, or any agency of any government.

Approved & Released For  
UL Verification Services Inc. By:

Prepared By:



CHIN PANG  
SENIOR ENGINEER  
UL VERIFICATION SERVICES INC.

TINA CHU  
LAB ENGINEER  
UL VERIFICATION SERVICES INC.

## 2. TEST METHODOLOGY

The tests documented in this report were performed in accordance with TIA-603-D, FCC CFR 47 Part 2, FCC CFR 47 Part 22, FCC CFR Part 24, FCC Part 27, FCC Part 90 and FCC KDB 971168 D01 v02r02. RSS-132 Issue 3, RSS-133 Issue 6 and RSS-139 Issue 3 and ANSI C63.26:2015,

## 3. FACILITIES AND ACCREDITATION

The test sites and measurement facilities used to collect data are located at 47173 and 47266 Benicia Street, Fremont, California, USA. The following table identifies which facilities were utilized for radiated emission measurements documented in this report. Specific facilities are also identified in the test results sections.

47173 Benicia Street		47266 Benicia Street	
<input type="checkbox"/>	Chamber A (IC:2324B-1)	<input checked="" type="checkbox"/>	Chamber D (IC:2324B-4)
<input type="checkbox"/>	Chamber B (IC:2324B-2)	<input checked="" type="checkbox"/>	Chamber E (IC:2324B-5)
<input type="checkbox"/>	Chamber C (IC:2324B-3)	<input type="checkbox"/>	Chamber F (IC:2324B-6)
		<input checked="" type="checkbox"/>	Chamber G (IC:2324B-7)
		<input type="checkbox"/>	Chamber H (IC:2324B-8)

The above test sites and facilities are covered under FCC Test Firm Registration # 208313. Chambers A through H are covered under Industry Canada company address code 2324B with site numbers 2324B -1 through 2324B-8, respectively.

UL Verification Services Inc. is accredited by NVLAP, Laboratory Code 200065-0. The full scope of accreditation can be viewed at <http://ts.nist.gov/standards/scopes/2000650.htm>.

## 4. CALIBRATION AND UNCERTAINTY

### 4.1. MEASURING INSTRUMENT CALIBRATION

The measuring equipment utilized to perform the tests documented in this report has been calibrated in accordance with the manufacturer's recommendations, and is traceable to recognized national standards.

## 4.2. SAMPLE CALCULATION

Where relevant, the following sample calculation is provided:

Field Strength (dBuV/m) = Measured Voltage (dBuV) + Antenna Factor (dB/m) + Cable Loss (dB) – Preamp Gain (dB)

36.5 dBuV + 18.7 dB/m + 0.6 dB – 26.9 dB = 28.9 dBuV/m

## 4.3. MEASUREMENT UNCERTAINTY

Where relevant, the following measurement uncertainty levels have been estimated for tests performed on the apparatus:

PARAMETER	UNCERTAINTY
Conducted Disturbance, 9KHz to 0.15 MHz	3.84 dB
Conducted Disturbance, 0.15 to 30 MHz	3.65 dB
Radiated Disturbance, 9KHz to 30 MHz	3.15 dB
Radiated Disturbance, 30 to 1000 MHz	5.36 dB
Radiated Disturbance, 1000 to 18000 MHz	4.32 dB
Radiated Disturbance, 18000 to 26000 MHz	4.45 dB
Radiated Disturbance, 26000 to 40000 MHz	5.24 dB

Uncertainty figures are valid to a confidence level of 95%.

## 5. EQUIPMENT UNDER TEST

### 5.1. DESCRIPTION OF EUT

The EUT, model number A1671, A1821 is a tablet with multimedia functions (music, application support, and video), Cellular GSM/GPRS/EGPRS/CDMA2000 1xRTT/1x Advanced/EVDO Rev.A/WCDMA /HSPA+/DC- HSDPA/LTE FDD & Carrier Aggregation/TDD/TD-SCDMA radio, IEEE 802.11a/b/g/n/ac radio, and Bluetooth radio. The rechargeable battery is not user accessible.

### 5.2. DESCRIPTION OF MODELS DIFFERENCES

Both Model A1671 and A1821 have identical PCB layout, design and functionality, except that A1671 supports second electronic-UICC based SIM or “soft SIM” (called eSIM) beside the regular UICC based SIM and A1821 will come with eSIM removed. RF and electromagnetic characteristic are independent of the eSIM element. Both Models have exactly same technology and band support. Model A1671 is used for EMC/RSE Testing and that data will be used for both Models

### 5.3. MAXIMUM OUTPUT POWER

#### EIRP/ERP TEST PROCEDURE

ANSI C63.26:2015/ TIA / EIA 603-D Clause 2.2.17  
KDB 971168 Section 5.6

$$\text{ERP/EIRP} = \text{PMeas} + \text{GT} - \text{LC}$$

where: ERP/EIRP = effective or equivalent radiated power, respectively (expressed in the same units as PMeas, typically dBW or dBm);

PMeas = measured transmitter output power or PSD, in dBm or dBW;

GT = gain of the transmitting antenna, in dBd (ERP) or dBi (EIRP);

LC = signal attenuation in the connecting cable between the transmitter and antenna, in dB.

For devices utilizing multiple antennas, KDB 662911 provides guidance for determining the effective array transmit antenna gain term to be used in the above equation.

The transmitter has a maximum average conducted and ERP / EIRP output powers as follows:

**5.3.1. ANTENNA C**

**GSM MODES**

<b>RSS 132 850MHz Band IC</b>							
Frequency range (MHz)	Modulation	Conducted (Average) (dBm)	Antenna Gain (dBi)	EIRP		Limit (dBm)	Margin (dB)
				dBm	mW		
824- 849	GPRS	33.50	0.24	33.74	2365.9	40.6	-6.9
	EGPRS	28.00	0.24	28.24	666.8	40.6	-12.4
<b>Part 22 850MHz Band FCC</b>							
Frequency range (MHz)	Modulation	Conducted (Average) (dBm)	Antenna Gain (dBi)	ERP		Limit (dBm)	Margin (dB)
				dBm	mW		
824-849	GPRS	33.50	0.24	31.59	1442.1	38.5	-6.9
	EGPRS	28.00	0.24	26.09	406.4	38.5	-12.4
<b>Part 24 / RSS 133 1900MHz Band</b>							
Frequency range (MHz)	Modulation	Conducted (Average) (dBm)	Antenna Gain (dBi)	EIRP		Limit (dBm)	Margin (dB)
				dBm	mW		
1850-1910	GPRS	29.50	1.47	30.97	1250.3	33.0	-2.0
	EGPRS	27.00	1.47	28.47	703.1	33.0	-4.5

**CDMA2000 MODES**

<b>Part 90 800MHz Band</b>							
Frequency range (MHz)	Modulation	Conducted (Average) (dBm)	Antenna Gain (dBi)	ERP		Limit (dBm)	Margin (dB)
				dBm	mW		
816-824	CDMA 1xRTT	26.00	0.24	24.09	256.4	50.0	-25.9
	CDMA EVDO Rev A	26.00	0.24	24.09	256.4	50.0	-25.9
<b>RSS 132 850MHz Band IC</b>							
Frequency range (MHz)	Modulation	Conducted (Average) (dBm)	Antenna Gain (dBi)	EIRP		Limit (dBm)	Margin (dB)
				dBm	mW		
824- 849	CDMA 1xRTT	24.50	0.24	24.74	297.9	40.6	-15.9
	CDMA EVDO-Rev A	24.50	0.24	24.74	297.9	40.6	-15.9
<b>Part 22 850MHz Band FCC</b>							
Frequency range (MHz)	Modulation	Conducted (Average) (dBm)	Antenna Gain (dBi)	ERP		Limit (dBm)	Margin (dB)
				dBm	mW		
824- 849	CDMA 1xRTT	24.50	0.24	22.59	181.6	38.5	-15.9
	CDMA EVDO-Rev A	24.50	0.24	22.59	181.6	38.5	-15.9
<b>Part 24 / RSS 133 1900MHz Band</b>							
Frequency range (MHz)	Modulation	Conducted (Average) (dBm)	Antenna Gain (dBi)	EIRP		Limit (dBm)	Margin (dB)
				dBm	mW		
1850-1910	CDMA 1xRTT	26.00	1.47	27.47	558.5	33.0	-5.5
	CDMA EVDO Rev A	26.00	1.47	27.47	558.5	33.0	-5.5

**UMTS MODE**

<b>RSS 132 850MHz Band IC</b>							
Frequency range (MHz)	Modulation	Conducted (Average) (dBm)	Antenna Gain (dBi)	EIRP		Limit (dBm)	Margin (dB)
				dBm	mW		
824- 849	REL 99	25.50	0.24	25.74	375.0	40.6	-14.9
	HSDPA	24.50	0.24	24.74	297.9	40.6	-15.9
<b>Part 22 850MHz Band FCC</b>							
Frequency range (MHz)	Modulation	Conducted (Average) (dBm)	Antenna Gain (dBi)	ERP		Limit (dBm)	Margin (dB)
				dBm	mW		
824-849	REL 99	25.50	0.24	23.59	228.6	38.5	-14.9
	HSDPA	24.50	0.24	22.59	181.6	38.5	-15.9
<b>Part 24 / RSS 133 1900MHz Band</b>							
Frequency range (MHz)	Modulation	Conducted (Average) (dBm)	Antenna Gain (dBi)	EIRP		Limit (dBm)	Margin (dB)
				dBm	mW		
1850-1910	REL 99	25.50	1.47	26.97	497.7	33.0	-6.0
	HSDPA	24.50	1.47	25.97	395.4	33.0	-7.0
<b>Part 27 / RSS 139 1700MHz Band</b>							
Frequency range (MHz)	Modulation	Conducted (Average) (dBm)	Antenna Gain (dBi)	EIRP		Limit (dBm)	Margin (dB)
				dBm	mW		
1710-1755	REL 99	25.50	0.29	25.79	379.3	30.0	-4.2
	HSDPA	24.50	0.29	24.79	301.3	30.0	-5.2

### 5.3.2. ANTENNA D

#### GSM MODES

<b>RSS 132 850MHz Band IC</b>							
Frequency range (MHz)	Modulation	Conducted (Average) (dBm)	Antenna Gain (dBi)	EIRP		Limit (dBm)	Margin (dB)
				dBm	mW		
824- 849	GPRS	32.00	0.51	32.51	1782.4	40.6	-8.1
	EGPRS	26.00	0.51	26.51	447.7	40.6	-14.1
<b>Part 22 850MHz Band FCC</b>							
Frequency range (MHz)	Modulation	Conducted (Average) (dBm)	Antenna Gain (dBi)	ERP		Limit (dBm)	Margin (dB)
				dBm	mW		
824-849	GPRS	32.00	0.51	30.36	1086.4	38.5	-8.1
	EGPRS	26.00	0.51	24.36	272.9	38.5	-14.1
<b>Part 24 / RSS 133 1900MHz Band</b>							
Frequency range (MHz)	Modulation	Conducted (Average) (dBm)	Antenna Gain (dBi)	EIRP		Limit (dBm)	Margin (dB)
				dBm	mW		
1850-1910	GPRS	27.50	1.07	28.57	719.4	33.0	-4.4
	EGPRS	24.00	1.07	25.07	321.4	33.0	-7.9

#### CDMA2000 MODES

<b>Part 90 800MHz Band</b>							
Frequency range (MHz)	Modulation	Conducted (Average) (dBm)	Antenna Gain (dBi)	ERP		Limit (dBm)	Margin (dB)
				dBm	mW		
816-824	CDMA 1xRTT	24.00	0.48	22.33	171.0	50.0	-27.7
	CDMA EVDO Rev A	24.00	0.48	22.33	171.0	50.0	-27.7
<b>RSS 132 850MHz Band IC</b>							
Frequency range (MHz)	Modulation	Conducted (Average) (dBm)	Antenna Gain (dBi)	EIRP		Limit (dBm)	Margin (dB)
				dBm	mW		
824- 849	CDMA 1xRTT	24.00	0.51	24.51	282.5	40.6	-16.1
	CDMA EVDO-Rev A	24.00	0.51	24.51	282.5	40.6	-16.1
<b>Part 22 850MHz Band FCC</b>							
Frequency range (MHz)	Modulation	Conducted (Average) (dBm)	Antenna Gain (dBi)	ERP		Limit (dBm)	Margin (dB)
				dBm	mW		
824- 849	CDMA 1xRTT	24.00	0.51	22.36	172.2	38.5	-16.1
	CDMA EVDO-Rev A	24.00	0.51	22.36	172.2	38.5	-16.1
<b>Part 24 / RSS 133 1900MHz Band</b>							
Frequency range (MHz)	Modulation	Conducted (Average) (dBm)	Antenna Gain (dBi)	EIRP		Limit (dBm)	Margin (dB)
				dBm	mW		
1850-1910	CDMA 1xRTT	23.50	1.07	24.57	286.4	33.0	-8.4
	CDMA EVDO Rev A	23.50	1.07	24.57	286.4	33.0	-8.4

**UMTS MODE**

<b>RSS 132 850MHz Band IC</b>							
Frequency range (MHz)	Modulation	Conducted (Average) (dBm)	Antenna Gain (dBi)	EIRP		Limit (dBm)	Margin (dB)
				dBm	mW		
824- 849	REL 99	25.00	0.51	25.51	355.6	40.6	-15.1
	HSDPA	24.00	0.51	24.51	282.5	40.6	-16.1
<b>Part 22 850MHz Band FCC</b>							
Frequency range (MHz)	Modulation	Conducted (Average) (dBm)	Antenna Gain (dBi)	ERP		Limit (dBm)	Margin (dB)
				dBm	mW		
824-849	REL 99	25.00	0.51	23.36	216.8	38.5	-15.1
	HSDPA	24.00	0.51	22.36	172.2	38.5	-16.1
<b>Part 24 / RSS 133 1900MHz Band</b>							
Frequency range (MHz)	Modulation	Conducted (Average) (dBm)	Antenna Gain (dBi)	EIRP		Limit (dBm)	Margin (dB)
				dBm	mW		
1850-1910	REL 99	24.50	1.07	25.57	360.6	33.0	-7.4
	HSDPA	23.50	1.07	24.57	286.4	33.0	-8.4
<b>Part 27 / RSS 139 1700MHz Band</b>							
Frequency range (MHz)	Modulation	Conducted (Average) (dBm)	Antenna Gain (dBi)	EIRP		Limit (dBm)	Margin (dB)
				dBm	mW		
1710-1755	REL 99	25.50	1.11	26.61	458.1	30.0	-3.4
	HSDPA	24.50	1.11	25.61	363.9	30.0	-4.4

## 5.4. DESCRIPTION OF AVAILABLE ANTENNAS

Frequency (MHz)	Antenna C Antenna Gain (dBi)	Antenna D Antenna Gain (dBi)
816 - 824	0.24	0.48
824 - 849	0.24	0.51
1850 - 1910	1.47	1.07
1710 - 1755	0.29	1.11

## 5.5. SOFTWARE AND FIRMWARE

The EUT software installed during testing was 14E32020u and firmware was 1.54.09.

## 5.6. WORST-CASE CONFIGURATION AND MODE

The worst-case is EUT on the highest power. Based on Peak Power measurement investigations, the following modes should be considered as worst-case scenario for all other measurements.

Worst-case modes:

- GSM GPRS
- GSM EGPRS
- CDMA 2000 1xRTT
- CDMA 2000 EVDO REV. A
- UMTS REL 99
- UMTS HSDPA

The EUT was investigated in three orthogonal orientations X/Y/Z. It was determined that X (Flatbed) orientation was worst-case orientation for cell band, secondary band, AWS band and PCS band without AC/DC adapter and headset.

Radiated spurious emissions were investigated below 30 MHz, from 30 MHz – 1 GHz, and above 1 GHz. There were no emissions found on below 30 MHz and 30 MHz - 1GHz.

## 5.7. DESCRIPTION OF TEST SETUP

### SUPPORT EQUIPMENT

Support Equipment List			
Description	Manufacturer	Model	Serial Number
Laptop AC Adapter	Dell	PA-1900-02D	N/A
Laptop	Dell	Latitude 3540	N/A
DC power supply	Sorensen	XT-20-3	N/A

### I/O CABLES (RF Conducted Test)

I/O Cable List						
Cable No	Port	# of identical ports	Connector Type	Cable Type	Cable Length (m)	Remarks
1	AC	3	US 115V	Un-shielded	2m	N/A
2	DC	1	DC	Un-shielded	1.4m	N/A
3	RF In/Out	1	EUT	Un-shielded	0.4m	N/A
4	RF In/Out	1	SMA	N/A	N/A	N/A
5	RF In/Out	1	SMA	Un-shielded	1m	N/A

### I/O CABLES (RF Radiated Test)

I/O Cable List						
Cable No	Port	# of identical ports	Connector Type	Cable Type	Cable Length (m)	Remarks
1	RF In/Out	1	Antenna	Un-shielded	5m	NA

### TEST SETUP

**CONDUCTED SETUP**

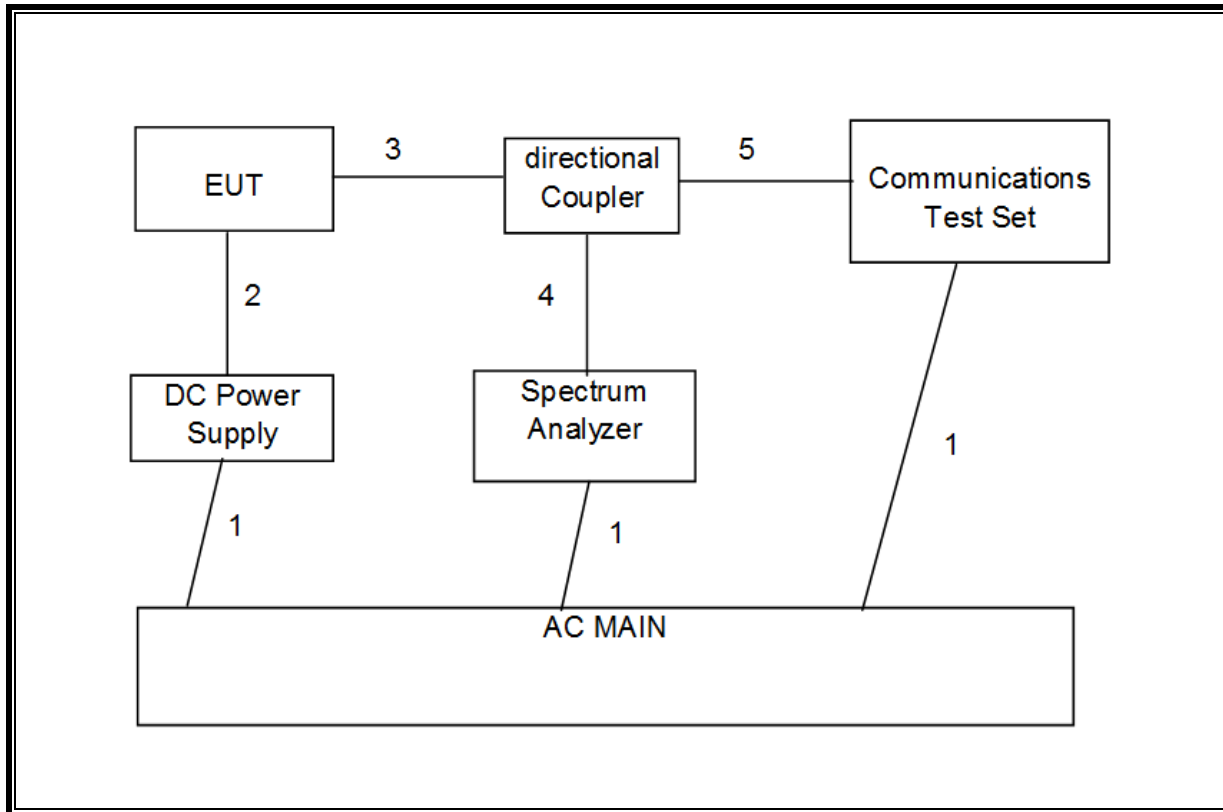

**RADIATED SETUP**

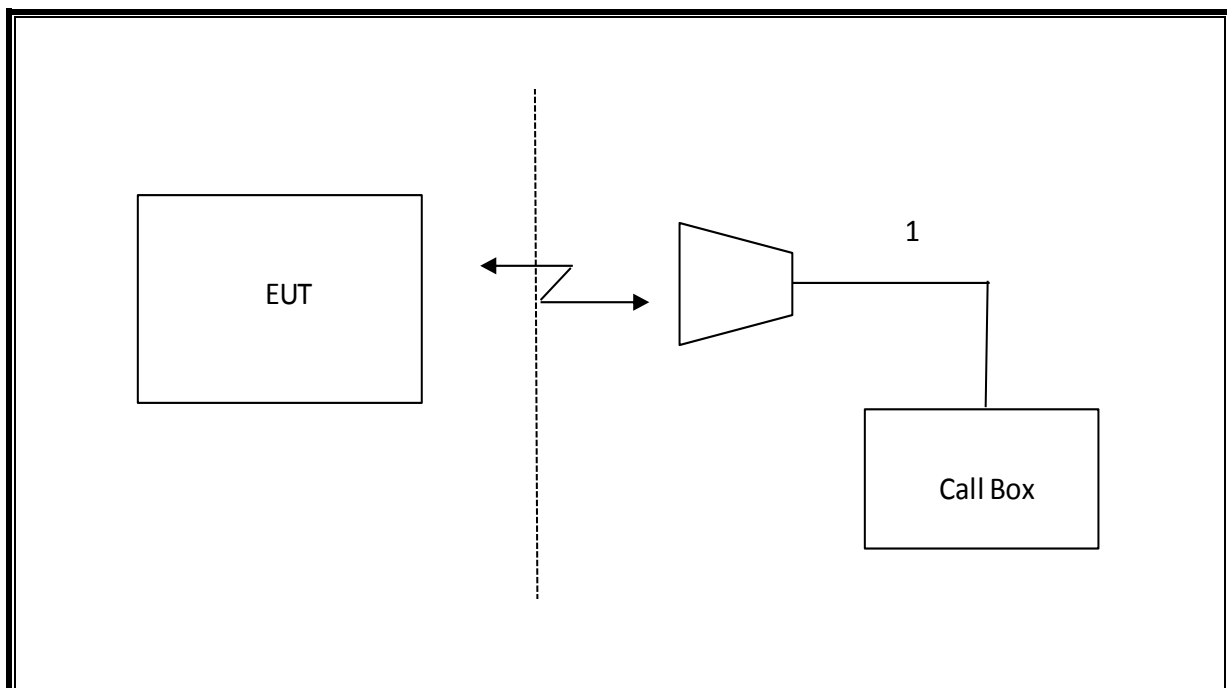

## 6. TEST AND MEASUREMENT EQUIPMENT

The following test and measurement equipment was utilized for the tests documented in this report:

TEST EQUIPMENT LIST				
Description	Manufacturer	Model	Asset	Cal Due
Antenna, Horn 1-18GHz	ETS Lindgren	3117	T863	04/26/2017
Antenna, Broadband Hybrid, 30MHz to 2000MHz	Sunol Sciences	JB3	T900	05/3/2017
Amplifier, 1 to 18GHz, 35dB	Amplical	AMP1G18-35	T1569	09/15/2017
Amplifier, 10KHz to 1GHz, 32dB	Sonoma	310N	T835	06/18/2017
* Spectrum Analyzer, PXA 3Hz to 44GHz	Keysight	N9030A	T906	02/03/2017
Directional Coupler	KRYTAR	152610	T1537	04/11/2017
Power Meter, P-series single channel	Keysight	N1912A	T1245	05/03/2017
Power Sensor, P - series, 50MHz to 18GHz, Wideband	Keysight	N1921A	T1226	05/18/2017
Power Sensor, P - series, 50MHz to 18GHz, Wideband	Keysight	N1921A	T750	10/17/2017
Directional Coupler	KRYTAR	152610	T1536	04/11/2017
* Filter, HPF 3.0GHz	MICROTRONICS	HPM17543	T487	01/26/2017
Filter, HPF 1.2GHz	Micro-Tronics	WHKX1.2/15G-6ST	T1182	05/31/2017
Spectrum Analyzer, PXA, 3Hz to 44GHz	Keysight	N9030A	T1466	03/09/2017
Wideband Communication Test Set, Call Box	Rohde & Schwarz GmbH & Co. KG	CMW500	T959	07/09/2017
Wideband Communication Test Set, Call Box	Rohde & Schwarz GmbH & Co. KG	CMW500	T971	08/05/2017
Chamber, Environmental	Cincinnati Sub Zero	ZPHS-8-3.5-SCT/WC	T1154	03/12/2017
Wideband Communication Test Set, Call Box	Rohde & Schwarz	CMW500	T260	07/20/2017
Antenna, Horn 18 to 26.5GHz	ARA	MWH-1826/B	T447	06/16/2017
Amplifier, 1 to 26.5GHz, 23.5dB Gain minimum	Keysight	8449B	T402	07/05/2017
Antenna, Horn 1-18GHz	Emco	3115	T59	11/18/2017

NOTE: \*testing is completed before equipment calibration expiration date.

## 7. RF POWER OUTPUT VERIFICATION

### 7.1. GSM

#### Using CMW500 Communication Test Set

Function: Menu select > GSM Mobile Station > GSM 850/900/1800/1900

Press **Connection control** to choose the different menus

Press **RESET** > choose all to reset all settings

Connection	Press <b>Signal Off</b> to turn off the signal and change settings Network Support > GSM+GPRS or GSM+EGPRS Main Service > Packet Data Service selection > Test Mode A – Auto Slot Config. off
MS Signal	Press Slot Config bottom on the right twice to select and change the number of time slots and power setting > Slot configuration > Uplink/Gamma > 33 dBm for GPRS 850/900 > 27 dBm for EGPRS 850/900 > 30 dBm for GPRS1800/1900 > 26 dBm for EGPRS1800/1900
BS Signal	Enter the same channel number for TCH channel (test channel) and BCCH channel  Frequency Offset > + 0 Hz Mode > BCCH and TCH BCCH Level > -85 dBm (May need to adjust if link is not stable) BCCH Channel > choose desire test channel [Enter the same channel number for TCH channel (test channel) and BCCH channel]  Channel Type > Off P0> 4 dB Slot Config > Unchanged (if already set under MS Signal) TCH > choose desired test channel Hopping > Off Main Timeslot > 3 (Default)
Network	Coding Scheme > CS 4 (GPRS) and MCS5-9 (EGPRS) Bit Stream > 2E9-1PSR Bit Pattern
AF/RF	Enter appropriate offsets for Ext. Att. Output and Ext. Att. Input
Connection	Press <b>Signal On</b> to turn on the signal and change settings

**Using Agilent 8960A Communication Test Set**

**System Config:** GSM/GPRS Mobile Test  
E1968A A.06.31

**Call Params:** BCH → Cell Band: GSM850/PCS  
TCH → Traffic Band: GSM850/PCS  
Traffic Channel: 128/192/251 or 512/661/810  
MS Tx Level: 0  
PDTCH → Traffic Band: GSM850/PCS  
Traffic Channel: 128/192/251 512/661/810  
MS Tx Level: 0  
Coding Scheme: CS-4 (GPRS)  
Coding Scheme: MCS-5 to 9 (EGPRS)  
MultiSlot Config: 1 up, 1 down (Assuming that the highest

conducted power)

**Control:** Active Cell → GSM/GPRS

### 7.1.1. GPRS/EGPRS

#### ANTENNA C

ID:	50820	Date:	2/1/17			
Mode	Ch.	f (MHz)	1 time slot		2 time slots	
			Peak (dBm)	Average (dBm)	Peak (dBm)	Average (dBm)
GPRS	128	824.2	33.50	33.40	32.50	32.40
	190	836.6	<b>33.60</b>	<b>33.50</b>	32.60	32.50
	251	848.8	33.50	33.40	32.50	32.40
EGPRS	128	824.2	30.90	27.90	30.80	27.80
	190	836.6	30.90	27.90	30.80	27.80
	251	848.8	<b>31.00</b>	<b>28.00</b>	30.80	27.80
GPRS	512	1850.2	29.50	29.40	29.40	29.30
	661	1880.0	29.50	29.40	29.40	29.30
	810	1909.8	<b>29.60</b>	<b>29.50</b>	29.50	29.40
EGPRS	512	1850.2	<b>30.10</b>	<b>27.00</b>	29.90	26.80
	661	1880.0	30.00	26.90	29.80	26.80
	810	1909.8	29.81	26.80	29.70	26.70

#### Antenna D (UAT)

ID:	50820	Date:	2/1/17			
Mode	Ch.	f (MHz)	1 time slot		2 time slots	
			Peak (dBm)	Average (dBm)	Peak (dBm)	Average (dBm)
GPRS	128	824.2	<b>32.10</b>	<b>32.00</b>	31.10	31.00
	190	836.6	32.00	31.90	31.00	30.90
	251	848.8	32.00	31.90	31.00	30.90
EGPRS	128	824.2	<b>29.20</b>	<b>26.00</b>	29.10	25.90
	190	836.6	29.00	25.80	28.90	25.80
	251	848.8	29.00	25.90	28.90	25.80
GPRS	512	1850.2	<b>27.60</b>	<b>27.50</b>	26.60	26.50
	661	1880.0	27.40	27.40	26.50	26.40
	810	1909.8	27.40	27.30	26.50	26.40
EGPRS	512	1850.2	<b>27.10</b>	<b>24.00</b>	24.70	21.60
	661	1880.0	27.00	23.90	24.60	21.50
	810	1909.8	26.90	23.80	24.60	21.50

## 7.2. CDMA200

Maximum output power is verified on the Low, Middle and High channels according to procedures in section 4.4.5.2 of 3GPP2 C.S0011/TIA-98-E for 1xRTT, section 3.1.2.3.4 of 3GPP2 C.S0033-0/TIA-866 for Rel. 0 and section 4.3.4 of 3GPP2 C.S0033-A for Rev. A

### 7.2.1. CDMA2000 1xRTT

This procedure assumes the Agilent 8960 Test Set has the following applications installed and with valid license.

<u>Application</u>	<u>Rev, License</u>
CDMA2000 Mobile Test	B.15.18, L

- Protocol Rev > 6 (IS-2000-0)
- System ID: 18; NID: 65535, Reg. Ch. #: 610 for Cell, 600 for PCS & 450 for AWS
- Radio Config (RC) > RC1 or RC3
- Service Option (SO) Setup > SO55 or SO32
- Traffic Data Rate > Full
- Rvs Power Ctrl > All Up bits (Maximum TxPout)

## RESULT

**ANTENNA C**

<b>ID:</b>	50820	<b>Date:</b>	2/1/17
------------	-------	--------------	--------

**1xRTT, BC10, SECONDARY 800**

Radio Configuration (RC)	Service Option (SO)	Conducted Output Power (dBm)					
		CH 450 - 817.25MHz		CH 560 - 820MHz		CH 670 - 822.75MHz	
		Peak	Average	Peak	Average	Peak	Average
RC1	2 (Loopback)	30.4	26.0	30.3	25.9	30.4	25.9
	55 (Loopback)	30.4	25.9	30.3	25.8	30.3	25.7
RC2	9 (Loopback)	30.1	25.9	30.4	25.9	30.3	25.8
	55 (Loopback)	<b>30.5</b>	<b>26.0</b>	30.4	25.9	30.3	25.9
RC3	2 (Loopback)	30.2	25.9	30.2	25.9	30.1	25.8
	55 (Loopback)	30.2	25.8	30.3	25.9	30.1	25.9
	32 (+ F-SCH)	30.2	25.8	30.2	25.8	30.3	25.9
	32 (+ SCH)	30.4	25.8	30.2	25.9	30.1	25.8
RC4	2 (Loopback)	30.5	25.8	30.4	25.8	30.1	25.9
	55 (Loopback)	30.4	25.8	30.4	25.8	30.1	25.9
	32 (+ F-SCH)	30.4	25.8	30.3	25.8	30.2	25.9
	32 (+ SCH)	30.4	25.8	30.4	25.9	30.2	25.9
RC5	9 (Loopback)	30.4	25.9	30.3	25.8	30.1	25.8
	55 (Loopback)	30.5	25.8	30.5	25.9	30.1	25.9
RC11	2 (Loopback)	30.5	25.9	30.4	26.0	30.2	25.9
	75 (Loopback)	30.5	25.8	30.3	25.9	30.2	25.9
	32 (+ F-SCH)	30.4	25.8	30.4	25.8	30.1	25.9
	32 (+ SCH)	30.4	25.8	30.4	25.8	30.2	25.8

**1xRTT, BC0, CELL BAND**

Radio Configuration (RC)	Service Option (SO)	Conducted Output Power (dBm)					
		CH 1013 - 824.7MHz		CH 384 - 836.52MHz		CH 777 - 848.31MHz	
		Peak	Average	Peak	Average	Peak	Average
RC1	2 (Loopback)	28.9	24.4	29.0	24.5	28.9	24.4
	55 (Loopback)	28.7	24.4	29.1	24.5	28.8	24.5
RC2	9 (Loopback)	28.7	24.4	29.0	24.4	28.8	24.5
	55 (Loopback)	28.7	24.4	<b>29.2</b>	<b>24.5</b>	29.0	24.4
RC3	2 (Loopback)	28.6	24.5	28.9	24.4	28.7	24.4
	55 (Loopback)	28.6	24.5	28.9	24.4	28.7	24.5
	32 (+ F-SCH)	28.7	24.3	29.0	24.4	28.8	24.4
	32 (+ SCH)	28.7	24.3	29.0	24.4	28.8	24.4
RC4	2 (Loopback)	28.6	24.5	29.0	24.4	28.7	24.4
	55 (Loopback)	28.6	24.5	28.9	24.4	28.7	24.4
	32 (+ F-SCH)	28.7	24.3	29.1	24.4	28.8	24.4
	32 (+ SCH)	28.7	24.3	28.9	24.4	28.8	24.3
RC5	9 (Loopback)	28.6	24.5	28.9	24.4	28.7	24.4
	55 (Loopback)	28.6	24.5	28.9	24.4	28.7	24.4
RC11	2 (Loopback)	28.6	24.4	29.0	24.4	28.8	24.4
	75 (Loopback)	28.6	24.4	29.0	24.4	28.7	24.4
	32 (+ F-SCH)	28.7	24.5	29.0	24.4	28.8	24.5
	32 (+ SCH)	28.6	24.4	28.9	24.5	28.7	24.5

**1xRTT, BC1, PCS BAND**

Radio Configuration (RC)	Service Option (SO)	Conducted Output Power (dBm)					
		CH 25 - 1851.25MHz		CH 600 - 1880MHz		CH 1175 - 1908.75MHz	
		Peak	Average	Peak	Average	Peak	Average
RC1	2 (Loopback)	29.9	25.8	30.0	25.8	29.4	25.9
	55 (Loopback)	29.9	25.8	30.1	25.8	29.3	25.9
RC2	9 (Loopback)	29.9	25.8	30.1	25.8	29.3	25.8
	55 (Loopback)	29.9	25.8	<b>30.2</b>	<b>26.0</b>	29.3	25.8
RC3	2 (Loopback)	29.8	25.9	29.4	25.7	29.4	25.9
	55 (Loopback)	29.8	25.9	30.1	25.8	29.3	26.0
	32 (+ F-SCH)	29.8	25.9	29.3	25.8	29.5	26.0
	32 (+ SCH)	29.8	25.8	29.3	25.8	29.4	25.8
RC4	2 (Loopback)	29.8	25.8	29.4	25.8	29.5	25.9
	55 (Loopback)	29.8	25.9	30.1	25.8	29.3	26.0
	32 (+ F-SCH)	29.9	25.8	29.3	25.8	29.5	25.9
	32 (+ SCH)	29.9	25.8	29.8	25.8	29.4	26.0
RC5	9 (Loopback)	29.8	25.9	30.0	25.8	29.5	25.9
	55 (Loopback)	29.8	25.9	30.1	25.8	29.4	26.0
RC11	2 (Loopback)	29.8	25.8	29.8	25.8	29.4	25.9
	75 (Loopback)	29.8	25.8	29.9	25.8	29.4	26.0
	32 (+ F-SCH)	29.8	25.9	29.9	25.8	29.5	26.0
	32 (+ SCH)	29.8	25.8	29.8	25.8	29.4	25.9

**ANTENNA D**

<b>ID:</b>	50820	<b>Date:</b>	2/1/17
------------	-------	--------------	--------

**1xRTT, BC10, SECONDARY 800**

Radio Configuration (RC)	Service Option (SO)	Conducted Output Power (dBm)					
		CH 450 - 817.25MHz		CH 560 - 820MHz		CH 670 - 822.75MHz	
		Peak	Average	Peak	Average	Peak	Average
RC1	2 (Loopback)	28.8	24.0	28.9	23.8	28.8	23.9
	55 (Loopback)	28.8	23.9	28.8	23.9	28.8	23.9
RC2	9 (Loopback)	28.8	23.9	28.8	23.8	28.8	23.9
	55 (Loopback)	<b>29.0</b>	<b>24.0</b>	28.7	23.9	28.8	23.9
RC3	2 (Loopback)	28.6	23.8	28.7	23.9	28.7	24.0
	55 (Loopback)	28.6	23.9	28.6	23.9	28.7	23.8
	32 (+ F-SCH)	28.6	23.9	28.7	23.8	28.8	23.9
	32 (+ SCH)	28.6	23.8	28.7	23.9	28.9	23.8
RC4	2 (Loopback)	28.7	24.0	28.7	23.9	28.7	24.0
	55 (Loopback)	28.6	23.8	28.6	23.9	28.7	23.9
	32 (+ F-SCH)	28.6	23.9	28.6	23.8	28.8	23.8
	32 (+ SCH)	28.6	23.9	29.0	23.8	28.8	23.8
RC5	9 (Loopback)	28.7	23.9	28.7	23.9	28.7	24.0
	55 (Loopback)	28.6	23.8	28.7	23.9	28.7	23.8
RC11	2 (Loopback)	28.6	23.8	28.7	23.9	28.7	24.0
	75 (Loopback)	28.6	23.8	28.7	23.9	28.7	23.9
	32 (+ F-SCH)	28.6	23.8	28.6	23.9	28.7	23.9
	32 (+ SCH)	28.6	23.8	28.6	23.9	28.6	23.9

**1xRTT, BC0, CELL BAND**

Radio Configuration (RC)	Service Option (SO)	Conducted Output Power (dBm)					
		CH 1013 - 824.7MHz		CH 384 - 836.52MHz		CH 777 - 848.31MHz	
		Peak	Average	Peak	Average	Peak	Average
RC1	2 (Loopback)	28.3	23.8	28.0	23.9	27.9	23.8
	55 (Loopback)	28.3	24.0	28.0	23.9	27.8	23.9
RC2	9 (Loopback)	28.3	23.9	28.0	23.9	27.8	23.9
	55 (Loopback)	<b>28.5</b>	<b>24.0</b>	28.2	23.9	28.3	23.9
RC3	2 (Loopback)	28.3	23.9	28.0	24.0	27.7	23.9
	55 (Loopback)	28.2	23.9	28.0	23.9	27.7	23.8
	32 (+ F-SCH)	28.3	23.9	28.1	23.8	27.7	23.7
	32 (+ SCH)	28.3	23.9	28.0	23.8	27.8	23.7
RC4	2 (Loopback)	28.2	23.8	28.0	23.9	27.7	23.9
	55 (Loopback)	28.2	23.8	28.0	23.9	27.7	23.9
	32 (+ F-SCH)	28.4	23.9	28.0	23.8	27.8	23.8
	32 (+ SCH)	28.4	23.8	28.1	23.8	27.9	23.7
RC5	9 (Loopback)	28.2	23.8	27.9	23.9	27.7	23.9
	55 (Loopback)	28.2	23.8	28.0	23.9	27.6	23.9
RC11	2 (Loopback)	28.4	23.9	28.0	24.0	27.9	23.8
	75 (Loopback)	28.4	23.9	28.0	23.9	27.7	23.7
	32 (+ F-SCH)	28.3	23.9	28.0	23.9	27.7	23.7
	32 (+ SCH)	28.4	23.9	28.0	23.9	27.7	23.7

**1xRTT, BC1, PCS BAND**

Radio Configuration (RC)	Service Option (SO)	Conducted Output Power (dBm)					
		CH 25 - 1851.25MHz		CH 600 - 1880MHz		CH 1175 - 1908.75MHz	
		Peak	Average	Peak	Average	Peak	Average
RC1	2 (Loopback)	27.8	23.3	27.9	23.2	27.8	23.3
	55 (Loopback)	27.7	23.3	28.1	23.3	27.8	23.3
RC2	9 (Loopback)	27.6	23.3	28.1	23.2	27.8	23.3
	55 (Loopback)	<b>28.4</b>	<b>23.5</b>	28.1	23.2	27.7	23.3
RC3	2 (Loopback)	27.5	23.2	27.7	23.3	27.6	23.4
	55 (Loopback)	27.5	23.2	27.7	23.3	27.5	23.2
	32 (+ F-SCH)	27.7	23.3	27.8	23.3	27.7	23.3
	32 (+ SCH)	27.7	23.2	27.7	23.3	27.2	23.4
RC4	2 (Loopback)	27.4	23.2	27.7	23.3	27.5	23.3
	55 (Loopback)	27.4	23.2	27.8	23.3	27.5	23.3
	32 (+ F-SCH)	27.8	23.2	27.7	23.3	27.7	23.3
	32 (+ SCH)	27.7	23.2	27.8	23.3	27.7	23.3
RC5	9 (Loopback)	27.4	23.3	27.8	23.3	27.5	23.2
	55 (Loopback)	27.4	23.3	27.6	23.3	27.4	23.3
RC11	2 (Loopback)	27.7	23.3	27.8	23.3	27.7	23.4
	75 (Loopback)	27.4	23.3	27.7	23.3	27.5	23.3
	32 (+ F-SCH)	27.4	23.3	27.7	23.3	27.4	23.3
	32 (+ SCH)	27.4	23.4	27.7	23.3	27.4	23.3

### 7.2.2. 1xEV-DO - Release 0 (REL 0)

This procedure assumes the Agilent 8960 Test Set has the following applications installed and with valid license.

#### EVDO Release 0 - RTAP

- Call Setup > Shift & Preset
- Call Control:
  - Access Network Info > Cell Parameters > Sector ID > 00000000 : 00000000 : 00000000 : 00000000 > Subnet Mask > 0
  - Generator Info > Channel Data Info > Termination Parameters > Max Forward Packet Duration > 16 Slots
- Call Params:
  - Cell Power > -105.5 dBm/1.23 MHz
  - Channel > (Enter channel number)
  - Application Config > Enhanced Test Application Protocol > RTAP
  - RTAP Rate > 153.6 kbps
  - Rvs Power Ctrl > Active bits
  - Protocol Rel > 0 (1xEV-DO)
- Press "Start Data Connection" when "Session Open" appear in "Active Cell"
- Rvs Power Ctrl > All Up bits (Maximum TxPout)

#### EVDO Release 0 - FTAP

- Call Setup > Shift & Preset
- Call Control:
  - Access Network Info > Cell Parameters > Sector ID > 00000000 : 00000000 : 00000000 : 00000000 > Subnet Mask > 0
  - Generator Info > Termination Parameters > Max Forward Packet Duration > 16 Slots
- Call Params:
  - Cell Power > -105.5 dBm/1.23 MHz
  - Cell Band > (Select US Cellular or US PCS)
  - Channel > (Enter channel number)
  - Application Config > Enhanced Test Application Protocol > FTAP (default)
  - FTAP Rate > 307.2 kbps (2 Slot, QPSK)
  - Rvs Power Ctrl > Active bits
  - Protocol Rel > 0 (1xEV-DO)
- Press "Start Data Connection" when "Session Open" appear in "Active Cell"
- Rvs Power Ctrl > All Up bits (Maximum TxPout)

## **RESULTS**

**ANTENNA C**

<b>ID:</b>	50820	<b>Date:</b>	2/1/17
------------	-------	--------------	--------

**EVDO REL 0 800MHz SECONDARY BAND**

FTAP Rate	RTAP Rate	Channel	f (MHz)	Conducted Output Power (dBm)	
				Peak	Average
307.2 kbps (2 Slot QPSK)	153.6 kbps	450	817.25	30.40	25.80
		560	820.00	<b>30.60</b>	<b>25.90</b>
		670	822.75	30.50	25.85

**EVDO REL 0 850MHz BAND**

FTAP Rate	RTAP Rate	Channel	Frequency (MHz)	Peak Conducted Power (dBm)	Average Conducted Power (dBm)
307.2 Kbps (2 slot QPSK)	153.6 Kbps	1013	824.70	28.60	24.30
		384	836.52	<b>28.80</b>	<b>24.45</b>
		777	848.31	28.70	24.40

**EVDO REL 0 1900MHz BAND**

FETAP Traffic Format	RETAP Data Payload Size	Channel	Frequency (MHz)	Peak Conducted Power (dBm)	Average Conducted Power (dBm)
307.2k, QPSK / ACK channel is transmitted at all the slots	4096	25	1851.25	30.40	25.85
		600	1880.00	<b>30.50</b>	<b>25.90</b>
		1175	1908.75	30.30	25.80

**ANTENNA D**

<b>ID:</b>	50820	<b>Date:</b>	2/1/17
------------	-------	--------------	--------

**EVDO REL 0 800MHz SECONDARY BAND**

FTAP Rate	RTAP Rate	Channel	f (MHz)	Conducted Output Power (dBm)	
				Peak	Average
307.2 kbps (2 Slot QPSK)	153.6 kbps	450	817.25	<b>28.20</b>	<b>23.90</b>
		560	820.00	27.92	23.80
		670	822.75	27.90	23.80

**EVDO REL 0 850MHz BAND**

FTAP Rate	RTAP Rate	Channel	Frequency (MHz)	Peak Conducted Power (dBm)	Average Conducted Power (dBm)
307.2 Kbps (2 slot QPSK)	153.6 Kbps	1013	824.70	<b>28.30</b>	<b>23.96</b>
		384	836.52	28.20	23.90
		777	848.31	28.17	23.88

**EVDO REL 0 1900MHz BAND**

FTAP Rate	RTAP Rate	Channel	Frequency (MHz)	Peak Conducted Power (dBm)	Average Conducted Power (dBm)
307.2 Kbps (2 slot QPSK)	153.6 Kbps	25	1851.25	<b>27.50</b>	<b>23.40</b>
		600	1880.00	27.38	23.30
		1175	1908.75	27.30	23.30

### 7.2.3. 1xEV-DO - Revision A (REV A)

This procedure assumes the Agilent 8960 Test Set has the following applications installed and with valid license.

<u>Application</u>	<u>Rev, License</u>
1xEV-DO Terminal Test	A.09.13

#### EVDO Rev. A – RETAP

- Call Setup > Shift & Preset
- Cell Power > -60 dBm/1.23 MHz
- Protocol Rev > A (1xEV-DO-A)
- Application Config > Enhanced Test Application Protocol > RETAP
- R-Data Pkt Size > 4096
- Protocol Subtype Config > Release A Physical Layer Subtype > Subtype 2
- > PL Subtype 2 Access Channel MAC Subtype > Default (Subtype 0)
- Access Network Info > Cell Parameters > Sector ID > 00000000: 00000000: 00000000: 00000000
- > Subnet Mask > 0
- Generator Info > Termination Parameters > Max Forward Packet Duration > 16 Slots
- > ACK R-Data After > Subpacket 0 (All ACK)
- Rvs Power Ctrl > All Up bits (to get the maximum power)

#### EVDO Rev. A - FETAP

- Call Setup > Shift & Preset
- Cell Power > -60 dBm/1.23 MHz
- Protocol Rev > A (1xEV-DO-A)
- Application Config > Enhanced Test Application Protocol > FETAP
- F-Traffic Format > 4 (1024, 2,128) Canonical (307.2k, QPSK)
- Protocol Subtype Config > Release A Physical Layer Subtype > Subtype 2
- > PL Subtype 2 Access Channel MAC Subtype > Default (Subtype 0)
- Access Network Info > Cell Parameters > Sector ID > 00000000: 00000000: 00000000: 00000000
- > Subnet Mask > 0
- Generator Info > Termination Parameters > Max Forward Packet Duration > 16 Slots
- > ACK R-Data After > Subpacket 0 (All ACK)
- Rvs Power Ctrl > All Up bits (to get the maximum power)

## **RESULTS**

**ANTENNA C**

<b>ID:</b>	50820	<b>Date:</b>	2/1/17
------------	-------	--------------	--------

**EVDO REV A 800MHz SECONDARY BAND**

FETAP Traffic Format	RETAP Data Payload Size	Channel	Frequency (MHz)	Peak Conducted Power (dBm)	Average Conducted Power (dBm)
307.2k, QPSK / ACK channel is transmitted at all the slots	4096	450	817.25	<b>30.80</b>	<b>26.00</b>
		560	820.00	30.70	25.90
		670	822.75	30.65	25.85

**EVDO REV A 850MHz BAND**

FETAP Traffic Format	RETAP Data Payload Size	Channel	Frequency (MHz)	Peak Conducted Power (dBm)	Average Conducted Power (dBm)
307.2k, QPSK / ACK channel is transmitted at all the slots	4096	1013	824.70	28.70	24.40
		384	836.52	<b>29.00</b>	<b>24.50</b>
		777	848.31	28.80	24.45

**EVDO REV A 1900MHz BAND**

FETAP Traffic Format	RETAP Data Payload Size	Channel	Frequency (MHz)	Peak Conducted Power (dBm)	Average Conducted Power (dBm)
307.2k, QPSK / ACK channel is transmitted at all the slots	4096	25	1851.25	30.50	25.90
		600	1880.00	<b>30.60</b>	<b>26.00</b>
		1175	1908.75	30.50	25.85

**ANTENNA D**

<b>ID:</b>	50820	<b>Date:</b>	2/1/17
------------	-------	--------------	--------

**EVDO REV A 800MHz SECONDARY BAND**

FETAP Traffic Format	RETAP Data Payload Size	Channel	Frequency (MHz)	Peak Conducted Power (dBm)	Average Conducted Power (dBm)
307.2k, QPSK / ACK channel is transmitted at all the slots	4096	450	817.25	<b>28.90</b>	<b>24.00</b>
		560	820.00	28.80	23.90
		670	822.75	28.75	23.85

**EVDO REV A 850MHz BAND**

FETAP Traffic Format	RETAP Data Payload Size	Channel	Frequency (MHz)	Peak Conducted Power (dBm)	Average Conducted Power (dBm)
307.2k, QPSK / ACK channel is transmitted at all the slots	4096	1013	824.70	28.45	23.90
		384	836.52	<b>28.70</b>	<b>24.00</b>
		777	848.31	28.50	23.92

**EVDO REV A 1900MHz BAND**

FETAP Traffic Format	RETAP Data Payload Size	Channel	Frequency (MHz)	Peak Conducted Power (dBm)	Average Conducted Power (dBm)
307.2k, QPSK / ACK channel is transmitted at all the slots	4096	25	1851.25	27.70	23.40
		600	1880.00	<b>27.80</b>	<b>23.50</b>
		1175	1908.75	27.73	23.46

### 7.3. UMTS

#### TEST PROCEDURE

The transmitter output was connected to the input terminal of Directional Coupler via calibrated coaxial cable. The output coupling terminal of the Directional Coupler was directly connected to a spectrum analyzer while the output through terminal connected to the communication test set via calibrated coaxial cable.

The output power was measured with the spectrum analyzer at the low, middle and high channel in each band.

- Set the spectrum analyzer span wide enough or greater than the modulated signal BW.
- Set a spectrum analyzer at peak detection mode with  $VBW \geq RBW \geq 26dB$  BW, typically 5MHz.
- Set a marker to point the corresponding peak value.

#### 7.3.1. UMTS REL99

The following summary of these settings are illustrated below:

	Mode	Rel99
	Subtest	-
WCDMA General Settings	Loopback Mode	Test Mode 1
	Rel99 RMC	12.2kbps RMC
	HSDPA FRC	Not Applicable
	HSUPA Test	Not Applicable
	Power Control Algorithm	Algorithm2
	$\beta_c$	Not Applicable
	$\beta_d$	Not Applicable
	$\beta_{ec}$	Not Applicable
	$\beta_c/\beta_d$	8/15
	$\beta_{hs}$	Not Applicable
	$\beta_{ed}$	Not Applicable

### RESULTS

**ANTENNA C**

<b>ID:</b>	29439	<b>Date:</b>	2/3/17
------------	-------	--------------	--------

**Part 22 / RSS 132 850MHz Band**

Band	UL Channel	DL Channel	Frequency (MHz)	Peak Power (dBm)	Average Power (dBm)
UMTS Rel. 99 850MHz	4132	4357	826.4	29.35	25.45
	4183	4408	836.6	<b>29.40</b>	<b>25.50</b>
	4233	4458	846.6	29.30	25.40

**Part 24 / RSS 133 1900MHz Band**

Band	UL Channel	DL Channel	Frequency (MHz)	Peak Power (dBm)	Average Power (dBm)
UMTS Rel. 99 1900MHz	9262	9662	1852.4	29.32	25.42
	9400	9800	1880.0	29.35	25.40
	9538	9938	1907.6	<b>29.42</b>	<b>25.50</b>

**Part 27 / RSS 139 1700MHz Band**

Band	UL Channel	DL Channel	Frequency (MHz)	Peak Power (dBm)	Average Power (dBm)
UMTS Rel. 99 1700MHz	1312	1537	1712.4	<b>29.46</b>	<b>25.50</b>
	1413	1638	1732.6	29.44	25.45
	1513	1738	1752.6	29.34	25.40

**ANTENNA D**

<b>ID:</b>	29439	<b>Date:</b>	2/3/17
------------	-------	--------------	--------

**Part 22 / RSS 132 850MHz Band**

Band	UL Channel	DL Channel	Frequency (MHz)	Peak Power (dBm)	Average Power (dBm)
UMTS Rel. 99 850MHz	4132	4357	826.4	29.20	24.90
	4183	4408	836.6	<b>29.30</b>	<b>25.00</b>
	4233	4458	846.6	29.15	24.85

**Part 24 / RSS 133 1900MHz Band**

Band	UL Channel	DL Channel	Frequency (MHz)	Peak Power (dBm)	Average Power (dBm)
UMTS Rel. 99 1900MHz	9262	9662	1852.4	28.35	24.40
	9400	9800	1880.0	<b>28.50</b>	<b>24.50</b>
	9538	9938	1907.6	28.30	24.35

**Part 27 / RSS 139 1700MHz Band**

Band	UL Channel	DL Channel	Frequency (MHz)	Peak Power (dBm)	Average Power (dBm)
UMTS Rel. 99 1700MHz	1312	1537	1712.4	<b>29.50</b>	<b>25.50</b>
	1413	1638	1732.6	29.40	25.40
	1513	1738	1752.6	29.35	25.42

### 7.3.2. HSDPA REL 5

The following 4 Sub-tests were completed according to Release 6 procedures in section 5.2 of 3GPP TS34.121.

Summary of settings are illustrated below:

	Mode	Rel5 HSDPA			
	Subtest	1	2	3	4
WCDMA General Settings	Loopback Mode	Test Mode 1			
	Rel99 RMC	12.2kbps RMC			
	HSDPA FRC	H-Set1			
	Power Control Algorithm	Algorithm 2			
	$\beta_c$	2/15	11/15	15/15	15/15
	$\beta_d$	15/15	15/15	8/15	4/15
	Bd (SF)	64			
	$\beta_c/\beta_d$	2/15	11/15	15/8	15/4
	$\beta_{hs}$	4/15	24/15	30/15	30/15
MPR (dB)	0	0	0.5	0.5	
HSDPA Specific Settings	$D_{ACK}$	8			
	$D_{NAK}$	8			
	DCQI	8			
	Ack-Nack repetition factor	3			
	CQI Feedback (Table 5.2B.4)	4ms			
	CQI Repetition Factor (Table 5.2B.4)	2			
	$A_{hs} = \beta_{hs}/\beta_c$	30/15			

## **RESULT**

**ANTENNA C**

<b>ID:</b>	29439	<b>Date:</b>	2/3/17
------------	-------	--------------	--------

**Part 22 / RSS 132 850MHz Band**

Band	Subtest	UL Channel	DL Channel	Frequency (MHz)	Peak Power (dBm)	Average Power (dBm)
UMTS HSDPA 850MHz	1	4132	4357	826.4	<b>28.50</b>	<b>24.50</b>
		4183	4408	836.6	28.36	24.40
		4233	4458	846.6	28.47	24.44
	2	4132	4357	826.4	28.36	24.47
		4183	4408	836.6	28.45	24.40
		4233	4458	846.6	28.40	24.43
	3	4132	4357	826.4	28.02	24.00
		4183	4408	836.6	28.36	23.90
		4233	4458	846.6	28.00	23.85
	4	4132	4357	826.4	28.04	24.00
		4183	4408	836.6	28.36	23.95
		4233	4458	846.6	28.00	23.92

**Part 24 / RSS 133 1900MHz Band**

Band	Subtest	UL Channel	DL Channel	Frequency (MHz)	Peak Power (dBm)	Average Power (dBm)
UMTS HSDPA 1900MHz	1	9262	9662	1852.4	29.30	24.48
		9400	9800	1880.0	<b>29.40</b>	<b>24.50</b>
		9538	9938	1907.6	29.20	24.40
	2	9262	9662	1852.4	29.06	24.40
		9400	9800	1880.0	29.03	24.37
		9538	9938	1907.6	28.85	24.42
	3	9262	9662	1852.4	28.70	24.00
		9400	9800	1880.0	28.60	23.95
		9538	9938	1907.6	28.65	23.90
	4	9262	9662	1852.4	28.90	23.85
		9400	9800	1880.0	28.80	24.00
		9538	9938	1907.6	28.70	23.90

**Part 27 / RSS 139 1700MHz Band**

Band	Subtest	UL Channel	DL Channel	Frequency (MHz)	Peak Power (dBm)	Average Power (dBm)
UMTS HSDPA 1700MHz	1	1312	1537	1712.4	29.20	24.49
		1413	1638	1732.6	<b>29.23</b>	<b>24.50</b>
		1513	1738	1752.6	29.18	24.40
	2	1312	1537	1712.4	29.12	24.48
		1413	1638	1732.6	29.10	24.46
		1513	1738	1752.6	29.03	24.40
	3	1312	1537	1712.4	28.80	24.00
		1413	1638	1732.6	28.90	23.95
		1513	1738	1752.6	28.70	24.00
	4	1312	1537	1712.4	28.67	23.80
		1413	1638	1732.6	28.80	23.85
		1513	1738	1752.6	28.70	24.00

**ANTENNA D**

<b>ID:</b>	29439	<b>Date:</b>	2/3/17
------------	-------	--------------	--------

**Part 22 / RSS 132 850MHz Band**

Band	Subtest	UL Channel	DL Channel	Frequency (MHz)	Peak Power (dBm)	Average Power (dBm)
UMTS HSDPA 850MHz	1	4132	4357	826.4	<b>28.00</b>	<b>24.00</b>
		4183	4408	836.6	27.80	23.80
		4233	4458	846.6	27.90	23.85
	2	4132	4357	826.4	27.75	23.96
		4183	4408	836.6	27.80	23.92
		4233	4458	846.6	27.72	23.95
	3	4132	4357	826.4	27.20	23.50
		4183	4408	836.6	27.30	23.40
		4233	4458	846.6	27.20	23.35
	4	4132	4357	826.4	27.17	23.60
		4183	4408	836.6	27.30	23.50
		4233	4458	846.6	27.25	23.52

**Part 24 / RSS 133 1900MHz Band**

Band	Subtest	UL Channel	DL Channel	Frequency (MHz)	Peak Power (dBm)	Average Power (dBm)
UMTS HSDPA 1900MHz	1	9262	9662	1852.4	<b>28.41</b>	<b>23.50</b>
		9400	9800	1880.0	28.30	23.40
		9538	9938	1907.6	28.40	23.30
	2	9262	9662	1852.4	28.38	23.45
		9400	9800	1880.0	28.10	23.30
		9538	9938	1907.6	28.21	23.30
	3	9262	9662	1852.4	27.40	23.10
		9400	9800	1880.0	27.45	23.00
		9538	9938	1907.6	27.30	22.95
	4	9262	9662	1852.4	27.40	22.95
		9400	9800	1880.0	27.60	22.90
		9538	9938	1907.6	27.30	23.00

**Part 27 / RSS 139 1700MHz Band**

Band	Subtest	UL Channel	DL Channel	Frequency (MHz)	Peak Power (dBm)	Average Power (dBm)
UMTS HSDPA 1700MHz	1	1312	1537	1712.4	<b>29.30</b>	<b>24.50</b>
		1413	1638	1732.6	29.00	24.30
		1513	1738	1752.6	29.18	24.35
	2	1312	1537	1712.4	29.23	24.45
		1413	1638	1732.6	29.10	24.40
		1513	1738	1752.6	29.20	24.40
	3	1312	1537	1712.4	28.90	24.00
		1413	1638	1732.6	28.95	24.02
		1513	1738	1752.6	28.80	23.95
	4	1312	1537	1712.4	28.90	23.95
		1413	1638	1732.6	28.75	23.95
		1513	1738	1752.6	29.04	23.90

### 7.3.3. HSPA REL 6 (HSDPA & HSUPA)

#### TEST PROCEDURE

The following summary of these settings are illustrated below:

	Mode	Rel6 HSUPA	Rel6 HSUPA	Rel6 HSUPA	Rel6 HSUPA	Rel6 HSUPA
	Subtest	1	2	3	4	5
WCDMA General Settings	Loopback Mode	Test Mode 1				
	Rel99 RMC	12.2kbps RMC				
	HSDPA FRC	H-Set1				
	HSUPA Test	HSUPA Loopback				
	Power Control Algorithm	Algorithm2				
	$\beta c$	11/15	6/15	15/15	2/15	15/15
	$\beta d$	15/15	15/15	9/15	15/15	0
	$\beta ec$	209/225	12/15	30/15	2/15	5/15
	$\beta c/\beta d$	11/15	6/15	15/9	2/15	15/1
	$\beta hs$	22/15	12/15	30/15	4/15	5/15
	$\beta ed$	1309/225	94/75	47/15	56/75	47/15
CM (dB)	1	3	2	3	1	
MPR (dB)	0	2	1	2	0	
HSDPA Specific Settings	DACK	8				
	DNAK	8				
	DCQI	8				
	Ack-Nack repetition factor	3				
	CQI Feedback (Table 5.2B.4)	4ms				
	CQI Repetition Factor (Table 5.2B.4)	2				
	$A_{hs} = \beta_{hs}/\beta_c$	30/15				
HSUPA Specific Settings	D E-DPCCH	6	8	8	5	7
	DHARQ	0	0	0	0	0
	AG Index	20	12	15	17	12
	ETFCI (from 34.121 Table C.11.1.3)	75	67	92	71	67
	Associated Max UL Data Rate kbps	242.1	174.9	482.8	205.8	308.9
	Reference E_TFCIs	E-TFCI 11 E-TFCI PO 4 E-TFCI 67 E-TFCI PO 18 E-TFCI 71 E-TFCI PO 23 E-TFCI 75 E-TFCI PO 26 E-TFCI 81 E-TFCI PO 27	E-TFCI 11 E-TFCI PO 4 E-TFCI 67 E-TFCI PO 18 E-TFCI 71 E-TFCI PO 23 E-TFCI 75 E-TFCI PO 26 E-TFCI 81 E-TFCI PO 27	E-TFCI 11 E-TFCI PO 4 E-TFCI 67 E-TFCI PO 18 E-TFCI 71 E-TFCI PO 23 E-TFCI 75 E-TFCI PO 26 E-TFCI 81 E-TFCI PO 27	E-TFCI 11 E-TFCI PO 4 E-TFCI 67 E-TFCI PO 18 E-TFCI 71 E-TFCI PO 23 E-TFCI 75 E-TFCI PO 26 E-TFCI 81 E-TFCI PO 27	E-TFCI 11 E-TFCI PO 4 E-TFCI 67 E-TFCI PO 18 E-TFCI 71 E-TFCI PO 23 E-TFCI 75 E-TFCI PO 26 E-TFCI 81 E-TFCI PO 27

#### RESULTS

**ANTENNA C**

<b>ID:</b>	29439	<b>Date:</b>	2/3/17
------------	-------	--------------	--------

**Part 22 / RSS 132 850MHz Band**

Band	Subtest	UL Channel	DL Channel	Frequency (MHz)	Peak Power (dBm)	Average Power (dBm)
UMTS HSUPA 850MHz	1	4132	4357	826.4	28.40	24.40
		4183	4408	836.6	<b>28.50</b>	<b>24.45</b>
		4233	4458	846.6	28.35	24.40
	2	4132	4357	826.4	26.70	22.50
		4183	4408	836.6	26.80	22.40
		4233	4458	846.6	26.90	22.45
	3	4132	4357	826.4	27.50	23.50
		4183	4408	836.6	27.40	23.60
		4233	4458	846.6	27.60	23.52
	4	4132	4357	826.4	26.65	22.40
		4183	4408	836.6	26.70	22.50
		4233	4458	846.6	26.73	22.47
	5	4132	4357	826.4	28.39	24.40
		4183	4408	836.6	28.36	24.36
		4233	4458	846.6	28.35	24.40

**Part 24 / RSS 133 1900MHz Band**

Band	Subtest	UL Ch	DL Ch	Frequency	Conducted Output Power (dBm)	
					Peak	Average
UMTS HSUPA 1900MHz (Band 2)	1	9262	9662	1852.4	28.95	24.50
		9400	9800	1880.0	28.90	24.35
		9538	9938	1907.6	<b>29.10</b>	<b>24.55</b>
	2	9262	9662	1852.4	27.10	22.60
		9400	9800	1880.0	27.05	22.50
		9538	9938	1907.6	27.20	22.50
	3	9262	9662	1852.4	28.00	23.60
		9400	9800	1880.0	28.10	23.50
		9538	9938	1907.6	28.15	23.45
	4	9262	9662	1852.4	27.20	22.40
		9400	9800	1880.0	27.30	22.45
		9538	9938	1907.6	27.24	22.50
	5	9262	9662	1852.4	29.00	24.50
		9400	9800	1880.0	28.95	24.40
		9538	9938	1907.6	28.90	24.45

**Part 27 / RSS 139 1700MHz Band**

Band	Subtest	UL Channel	DL Channel	Frequency (MHz)	Peak Power (dBm)	Average Power (dBm)
UMTS HSUPA 1700MHz	1	1312	1537	1712.4	<b>29.35</b>	<b>24.50</b>
		1413	1638	1732.6	29.30	24.40
		1513	1738	1752.6	29.25	24.40
	2	1312	1537	1712.4	28.84	22.40
		1413	1638	1732.6	28.75	22.45
		1513	1738	1752.6	28.83	22.37
	3	1312	1537	1712.4	29.19	23.40
		1413	1638	1732.6	29.11	23.50
		1513	1738	1752.6	29.01	23.37
	4	1312	1537	1712.4	28.65	22.40
		1413	1638	1732.6	28.58	22.35
		1513	1738	1752.6	28.69	22.40
	5	1312	1537	1712.4	29.25	24.40
		1413	1638	1732.6	29.19	24.35
		1513	1738	1752.6	29.27	24.40

**ANTENNA D**

<b>ID:</b>	29439	<b>Date:</b>	2/3/17
------------	-------	--------------	--------

**Part 22 / RSS 132 850MHz Band**

Band	Subtest	UL Channel	DL Channel	Frequency (MHz)	Peak Power (dBm)	Average Power (dBm)
UMTS HSUPA 850MHz	1	4132	4357	826.4	<b>28.10</b>	<b>23.95</b>
		4183	4408	836.6	28.05	23.90
		4233	4458	846.6	27.95	23.85
	2	4132	4357	826.4	27.00	22.00
		4183	4408	836.6	26.80	21.90
		4233	4458	846.6	26.85	21.95
	3	4132	4357	826.4	27.65	23.00
		4183	4408	836.6	27.70	22.95
		4233	4458	846.6	27.80	23.10
	4	4132	4357	826.4	26.96	22.00
		4183	4408	836.6	27.05	21.93
		4233	4458	846.6	27.00	22.37
	5	4132	4357	826.4	27.94	23.92
		4183	4408	836.6	27.85	23.87
		4233	4458	846.6	27.90	23.90

**Part 24 / RSS 133 1900MHz Band**

Band	Subtest	UL Ch	DL Ch	Frequency	Conducted Output Power (dBm)	
					Peak	Average
UMTS HSUPA 1900MHz	1	9262	9662	1852.4	27.85	22.90
		9400	9800	1880.0	<b>27.92</b>	<b>22.95</b>
		9538	9938	1907.6	27.75	22.87
	2	9262	9662	1852.4	26.15	21.00
		9400	9800	1880.0	26.20	21.05
		9538	9938	1907.6	26.27	21.10
	3	9262	9662	1852.4	27.20	22.05
		9400	9800	1880.0	27.25	22.12
		9538	9938	1907.6	27.28	22.00
	4	9262	9662	1852.4	26.30	21.02
		9400	9800	1880.0	26.35	21.00
		9538	9938	1907.6	26.40	20.95
	5	9262	9662	1852.4	27.68	22.92
		9400	9800	1880.0	27.85	22.90
		9538	9938	1907.6	27.78	22.85

**Part 27 / RSS 139 1700MHz Band**

Band	Subtest	UL Channel	DL Channel	Frequency (MHz)	Peak Power (dBm)	Average Power (dBm)
UMTS HSUPA 1700MHz	1	1312	1537	1712.4	<b>28.70</b>	<b>24.45</b>
		1413	1638	1732.6	28.50	24.40
		1513	1738	1752.6	28.48	24.40
	2	1312	1537	1712.4	26.60	22.50
		1413	1638	1732.6	26.50	22.55
		1513	1738	1752.6	26.65	22.43
	3	1312	1537	1712.4	27.50	23.50
		1413	1638	1732.6	27.40	23.40
		1513	1738	1752.6	27.38	23.52
	4	1312	1537	1712.4	26.50	22.40
		1413	1638	1732.6	26.62	22.45
		1513	1738	1752.6	26.45	22.50
	5	1312	1537	1712.4	28.38	24.40
		1413	1638	1732.6	28.42	24.40
		1513	1738	1752.6	28.36	24.35

**7.3.4. DUAL CARRIER HSDPA**

**DC-HSDPA (Rel 8, CAT 24)**

The following tests were completed according to procedures in section 7.3.13 of 3GPP TS34.108 v9.5.0. A summary of these settings are illustrated below:  
 Downlink Physical Channels are set as per 3GPP TS34.121-1 v9.0.0 E.5.0

**Table E.5.0: Levels for HSDPA connection setup**

Parameter During Connection setup	Unit	Value
P-CPICH_Ec/Ior	dB	-10
P-CCPCH and SCH_Ec/Ior	dB	-12
PICH_Ec/Ior	dB	-15
HS-PDSCH	dB	off
HS-SCCH_1	dB	off
DPCH_Ec/Ior	dB	-5
OCNS_Ec/Ior	dB	-3.1

Call is set up as per 3GPP TS34.108 v9.5.0 sub clause 7.3.13

The configurations of the fixed reference channels for HSDPA RF tests are described in 3GPP TS 34.121, annex C for FDD and 3GPP TS 34.122.

**Table C.8.1.12: Fixed Reference Channel H-Set 12**

Parameter	Unit	Value
Nominal Avg. Inf. Bit Rate	kbps	60
Inter-TTI Distance	TTI's	1
Number of HARQ Processes	Processes	6
Information Bit Payload ( $N_{INF}$ )	Bits	120
Number Code Blocks	Blocks	1
Binary Channel Bits Per TTI	Bits	960
Total Available SML's in UE	SML's	19200
Number of SML's per HARQ Proc.	SML's	3200
Coding Rate		0.15
Number of Physical Channel Codes	Codes	1
Modulation		QPSK
Note 1: The RMC is intended to be used for DC-HSDPA mode and both cells shall transmit with identical parameters as listed in the table. Note 2: Maximum number of transmission is limited to 1, i.e., retransmission is not allowed. The redundancy and constellation version 0 shall be used.		

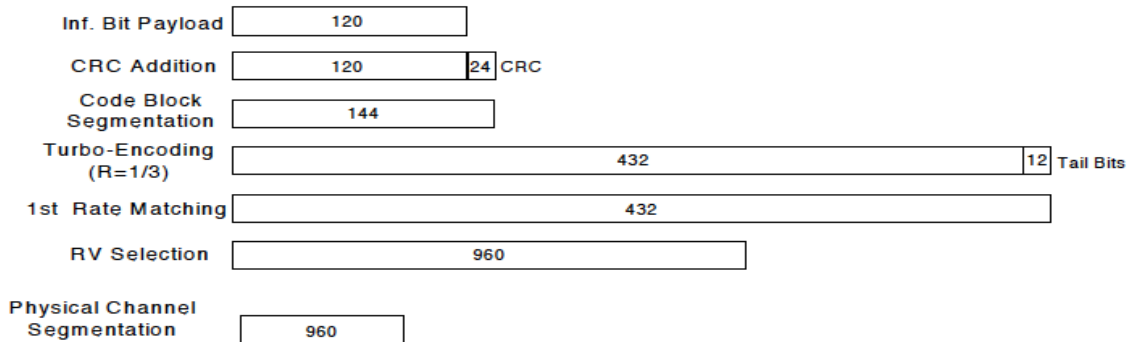

**Figure C.8.19: Coding rate for Fixed reference Channel H-Set 12 (QPSK)**

The following 4 Sub-tests for HSDPA were completed according to Release 6 procedures in section 5.2 of 3GPP TS34.121. A summary of subtest settings are illustrated below:

	Mode	Rel6 HSDPA	Rel6 HSDPA	Rel6 HSDPA	Rel6 HSDPA
	Subtest	1	2	3	4
WCDMA General Settings	Loopback Mode	Test Mode 1			
	Rel99 RMC	12.2kbps RMC			
	HSDPA FRC	H-Set1			
	Power Control Algorithm	Algorithm2			
	$\beta_c$	2/15	12/15	15/15	15/15
	$\beta_d$	15/15	15/15	8/15	4/15
	$\beta_d$ (SF)	64			
	$\beta_c/\beta_d$	2/15	12/15	15/8	15/4
	$\beta_{hs}$	4/15	24/15	30/15	30/15
MPR	0	0	0.5	0.5	
HSDPA Specific Settings	DACK	8			
	DNAK	8			
	DCQI	8			
	Ack-Nack Repetition factor	3			
	CQI Feedback	4ms			
	CQI Repetition Factor	2			
	Ahs = $\beta_{hs} / \beta_c$	30/15			

**RESULT**

**ANTENNA C**

<b>ID:</b>	50820	<b>Date:</b>	2/3/17
------------	-------	--------------	--------

**Part 22 / RSS 132 850MHz Band**

Band	Subtest	UL Channel	DL Channel	Frequency (MHz)	Peak Power (dBm)	Average Power (dBm)
UMTS HSDPA 850MHz	1	4132	4357	826.4	28.95	24.40
		4183	4408	836.6	<b>29.08</b>	<b>24.45</b>
		4233	4458	846.6	29.00	24.42
	2	4132	4357	826.4	28.67	24.37
		4183	4408	836.6	28.81	24.40
		4233	4458	846.6	28.91	24.40
	3	4132	4357	826.4	28.63	24.00
		4183	4408	836.6	28.50	23.95
		4233	4458	846.6	28.54	23.90
	4	4132	4357	826.4	28.45	24.00
		4183	4408	836.6	28.63	24.00
		4233	4458	846.6	28.50	23.90

**Part 24 / RSS 133 1900MHz Band**

Band	Subtest	UL Channel	DL Channel	Frequency (MHz)	Peak Power (dBm)	Average Power (dBm)
UMTS HSDPA 1900MHz	1	9262	9662	1852.4	<b>28.80</b>	<b>24.50</b>
		9400	9800	1880.0	28.70	24.40
		9538	9938	1907.6	28.75	24.45
	2	9262	9662	1852.4	28.68	24.43
		9400	9800	1880.0	28.70	24.40
		9538	9938	1907.6	28.74	24.46
	3	9262	9662	1852.4	28.30	24.00
		9400	9800	1880.0	28.15	23.95
		9538	9938	1907.6	28.20	24.00
	4	9262	9662	1852.4	28.05	23.86
		9400	9800	1880.0	27.95	23.90
		9538	9938	1907.6	28.00	23.96

**Part 27 / RSS 139 1700MHz Band**

Band	Subtest	UL Channel	DL Channel	Frequency (MHz)	Peak Power (dBm)	Average Power (dBm)
UMTS HSDPA 1700MHz	1	1312	1537	1712.4	28.80	24.40
		1413	1638	1732.6	28.70	24.45
		1513	1738	1752.6	<b>28.85</b>	<b>24.50</b>
	2	1312	1537	1712.4	28.68	24.42
		1413	1638	1732.6	28.80	24.40
		1513	1738	1752.6	28.65	24.46
	3	1312	1537	1712.4	28.10	24.00
		1413	1638	1732.6	28.15	23.97
		1513	1738	1752.6	28.20	24.00
	4	1312	1537	1712.4	28.00	23.95
		1413	1638	1732.6	28.16	23.86
		1513	1738	1752.6	28.23	23.90

**ANTENNA D**

<b>ID:</b>	50820	<b>Date:</b>	2/3/17
------------	-------	--------------	--------

**Part 22 / RSS 132 850MHz Band**

Band	Subtest	UL Channel	DL Channel	Frequency (MHz)	Peak Power (dBm)	Average Power (dBm)
UMTS HSDPA 850MHz	1	4132	4357	826.4	28.60	23.90
		4183	4408	836.6	<b>28.65</b>	<b>23.95</b>
		4233	4458	846.6	28.57	23.92
	2	4132	4357	826.4	28.40	23.90
		4183	4408	836.6	28.54	23.85
		4233	4458	846.6	28.47	23.80
	3	4132	4357	826.4	28.20	23.50
		4183	4408	836.6	28.05	23.40
		4233	4458	846.6	28.22	23.35
	4	4132	4357	826.4	28.30	23.50
		4183	4408	836.6	28.25	23.40
		4233	4458	846.6	28.20	23.43

**Part 24 / RSS 133 1900MHz Band**

Band	Subtest	UL Channel	DL Channel	Frequency (MHz)	Peak Power (dBm)	Average Power (dBm)
UMTS HSDPA 1900MHz	1	9262	9662	1852.4	<b>27.80</b>	<b>23.00</b>
		9400	9800	1880.0	27.75	22.86
		9538	9938	1907.6	27.70	22.86
	2	9262	9662	1852.4	27.70	22.86
		9400	9800	1880.0	27.75	22.85
		9538	9938	1907.6	27.72	22.75
	3	9262	9662	1852.4	27.30	22.50
		9400	9800	1880.0	27.23	22.55
		9538	9938	1907.6	27.40	22.60
	4	9262	9662	1852.4	27.45	22.45
		9400	9800	1880.0	27.30	22.40
		9538	9938	1907.6	27.25	22.50

**Part 27 / RSS 139 1700MHz Band**

Band	Subtest	UL Channel	DL Channel	Frequency (MHz)	Peak Power (dBm)	Average Power (dBm)
UMTS HSDPA 1700MHz	1	1312	1537	1712.4	<b>29.00</b>	<b>24.45</b>
		1413	1638	1732.6	28.80	24.30
		1513	1738	1752.6	28.75	24.40
	2	1312	1537	1712.4	28.70	24.40
		1413	1638	1732.6	28.92	24.30
		1513	1738	1752.6	28.90	24.42
	3	1312	1537	1712.4	28.41	24.00
		1413	1638	1732.6	28.42	23.95
		1513	1738	1752.6	28.40	23.85
	4	1312	1537	1712.4	28.42	23.95
		1413	1638	1732.6	28.45	23.90
		1513	1738	1752.6	28.20	24.00

## **8. CONDUCTED TEST RESULTS**

### **8.1. OCCUPIED BANDWIDTH**

#### **RULE PART(S)**

FCC: §2.1049

IC: RSS132; RSS133§2.3; RSS139

#### **LIMITS**

For reporting purposes only

#### **TEST PROCEDURE**

The transmitter output was connected to a calibrated coaxial cable and coupler, the other end of which was connected to a spectrum analyzer. The occupied bandwidth was measured with the spectrum analyzer at the middle channel in each band. The 99% and -26dB bandwidths was also measured and recorded.

#### **RESULTS**

There is no limit required and power is the same for low, middle and high channel; therefore, only middle channel was tested.

**GSM GPRS MODE PART 22 AND 24 / RSS 132 AND 133**

Band	Mode	Channel	f(MHz)	99% BW (KHz)	-26dB BW (KHz)
CELL	GPRS	190	836.6	248.5569	313.104
PCS	GPRS	661	1880	239.6962	291.791

**GSM EGPRS MODE PART 22 AND 24 / RSS 132 AND 133**

Band	Mode	Channel	f(MHz)	99% BW (KHz)	-26dB BW (KHz)
CELL	EGPRS	190	836.6	249.9044	308.049
PCS	EGPRS	661	1880	252.0367	309.740

**CDMA2000 1xRTT MODE PART 22, 24 AND 90 / RSS 132, 133 AND 139**

Band	Mode	Channel	f(MHz)	99% BW (MHz)	-26dB BW (MHz)
CELL	CDMA 2000 1xRTT	384	836.5	1.2731	1.421
PCS	CDMA 2000 1xRTT	600	1880	1.2758	1.427
800MHz Secondary	CDMA 2000 1xRTT	560	820	1.2739	1.421

**CDMA2000 EVDO Rev A MODE PART 22, 24 AND 90 / RSS 132, 133 AND 139**

Band	Mode	Channel	f(MHz)	99% BW (MHz)	-26dB BW (MHz)
CELL	CDMA 2000 EVDO Rev. A	384	836.5	1.2781	1.427
PCS	CDMA 2000 1xRTT	600	1880	1.2794	1.410
800MHz Secondary	CDMA 2000 1xRTT	560	820	1.2770	1.428

**UMTS REL 99 MODE PART 22, 24, AND 27 / RSS 132, 133 AND 139**

Band	Mode	DL Channel	f(MHz)	99% BW (MHz)	-26dB BW (MHz)
850MHz	UMTS Rel. 99	4408	836.6	4.1460	4.691
1900MHz		9800	1880	4.1309	4.718
1700MHz		1638	1732.6	4.1287	4.694

**UMTS HSDPA MODE PART 22, 24 AND 27 / RSS 132, 133 AND 139**

Band	Mode	DL Channel	f(MHz)	99% BW (MHz)	-26dB BW (MHz)
850MHz	UMTS HSDPA	4408	836.6	4.1183	4.694
1900MHz		9800	1880	4.1663	4.675
1700MHz		1638	1732.6	4.1312	4.678

### 8.1.1. GSM GPRS

#### 850MHz BAND

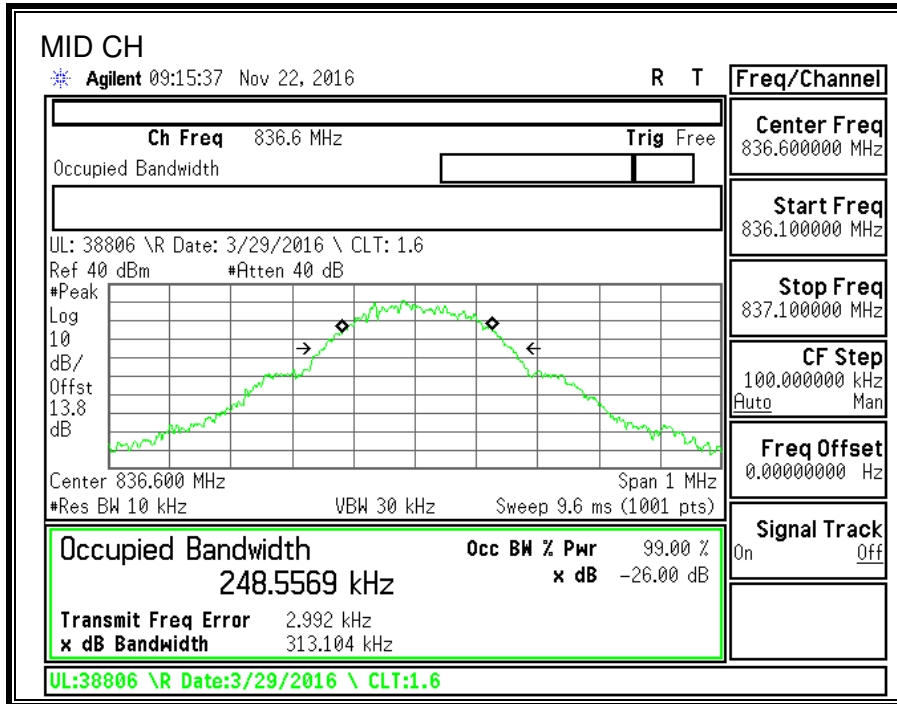

#### 1900MHz BAND

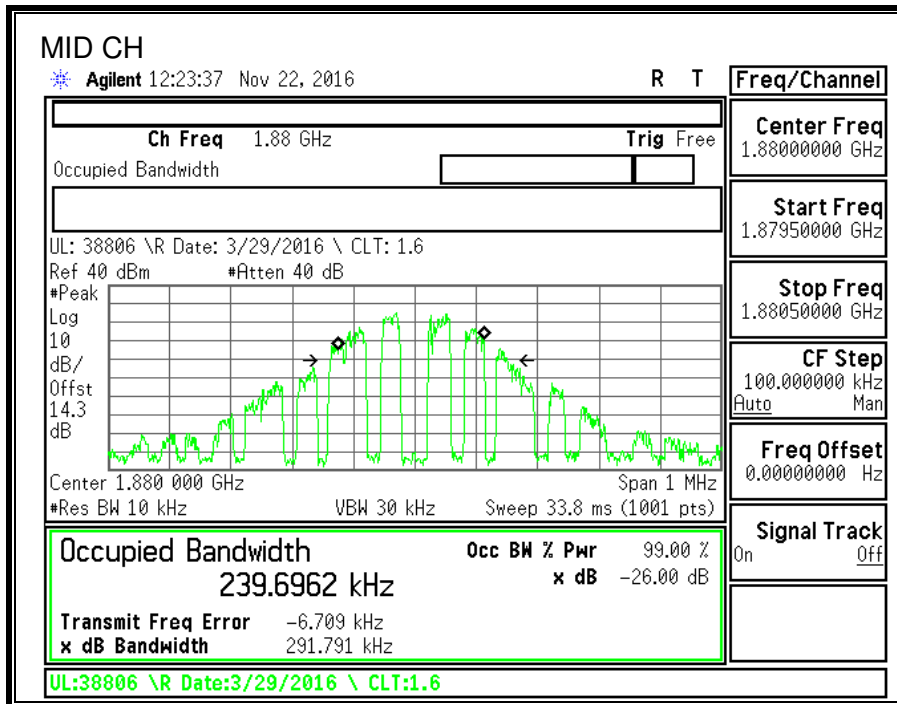

### 8.1.2. GSM EGPRS

#### 850MHz BAND

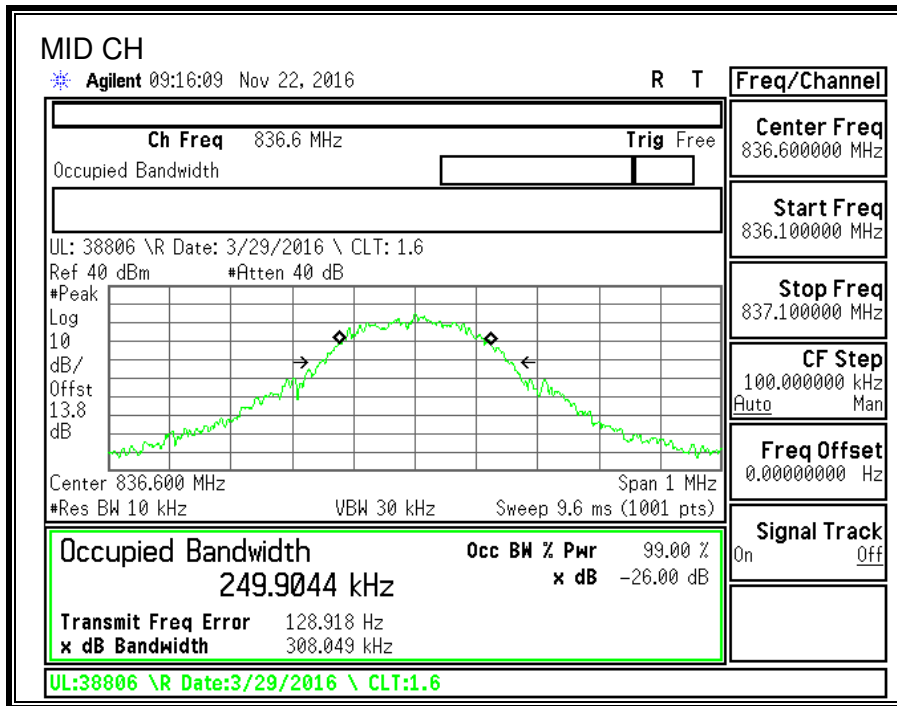

#### 1900MHz BAND

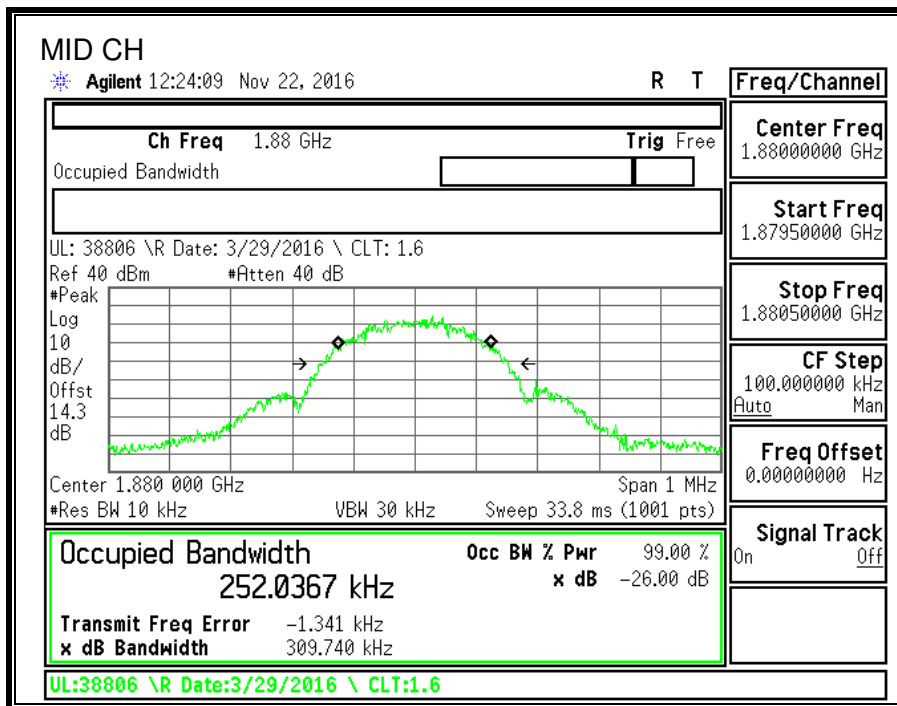

### 8.1.3. CDMA2000 1xRTT

#### 850MHz BAND

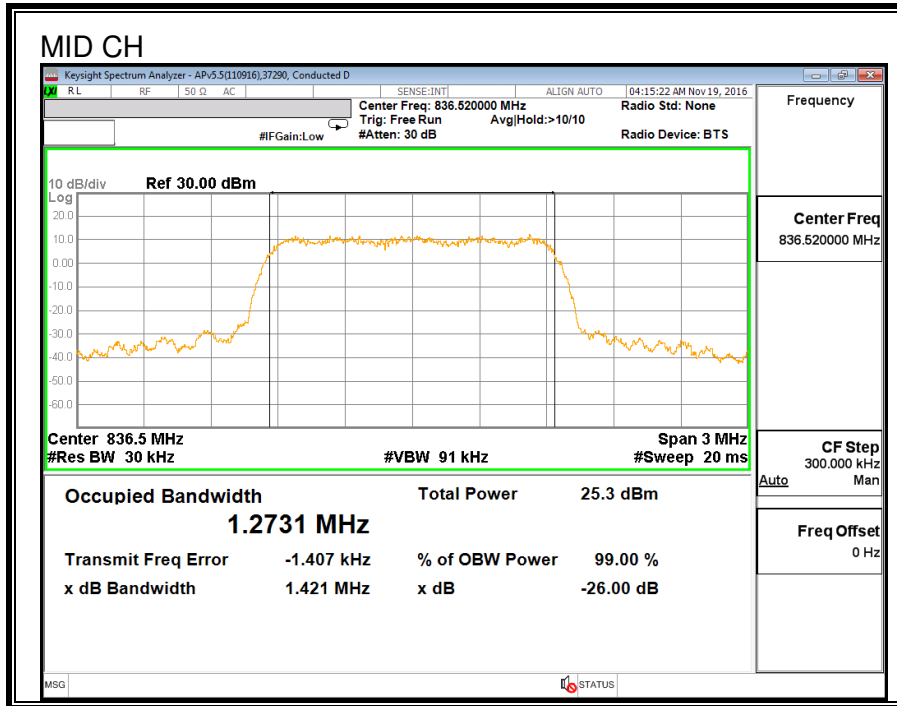

#### 1900MHz BAND

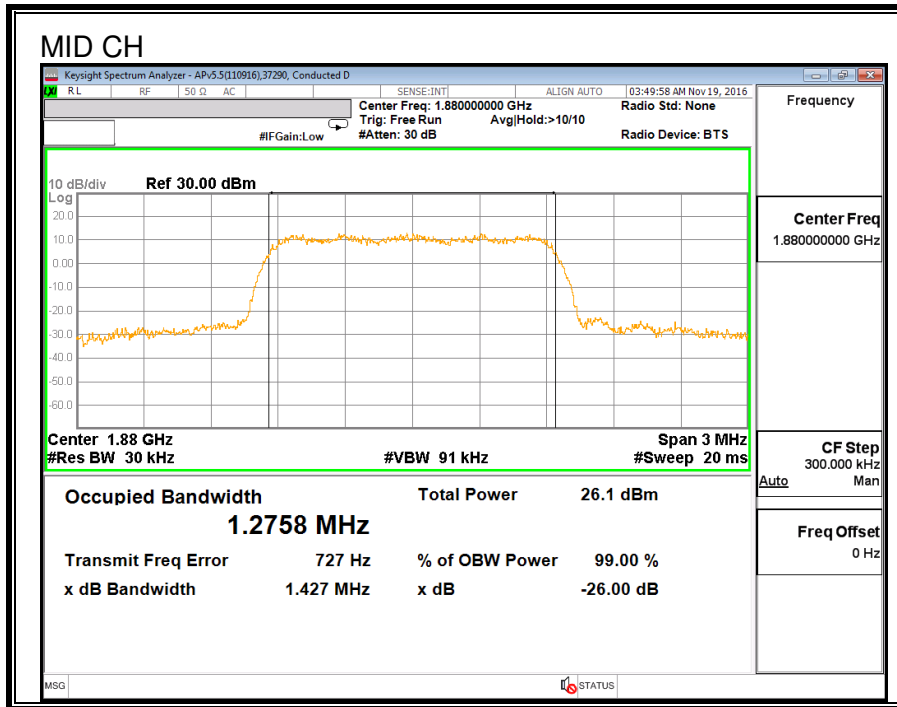

**800MHz SECONDARY BAND**

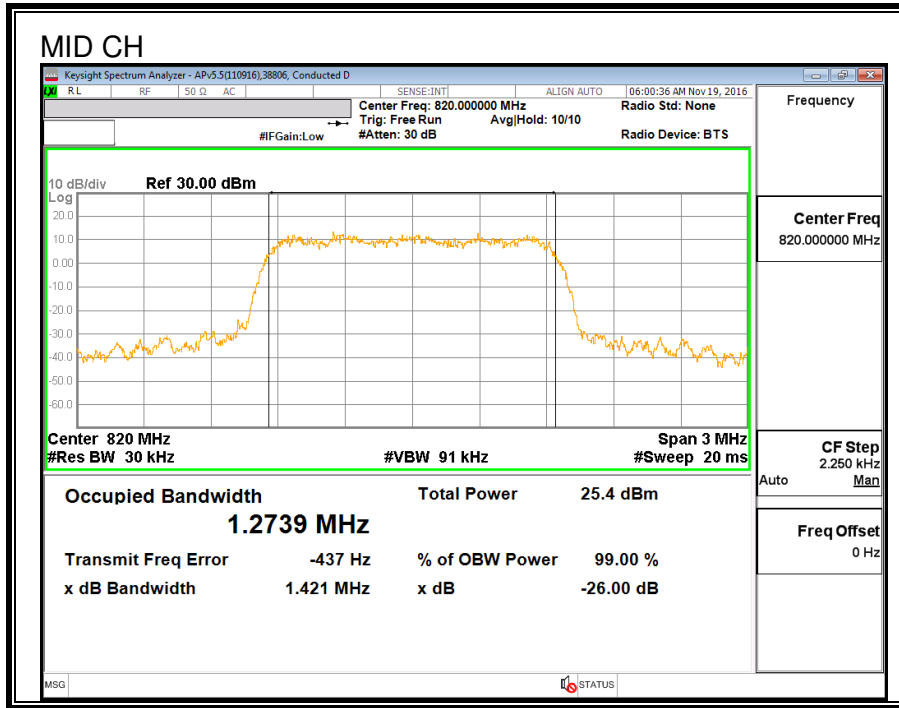

### 8.1.4. CDMA2000 EVDO REV A

#### 850MHz BAND

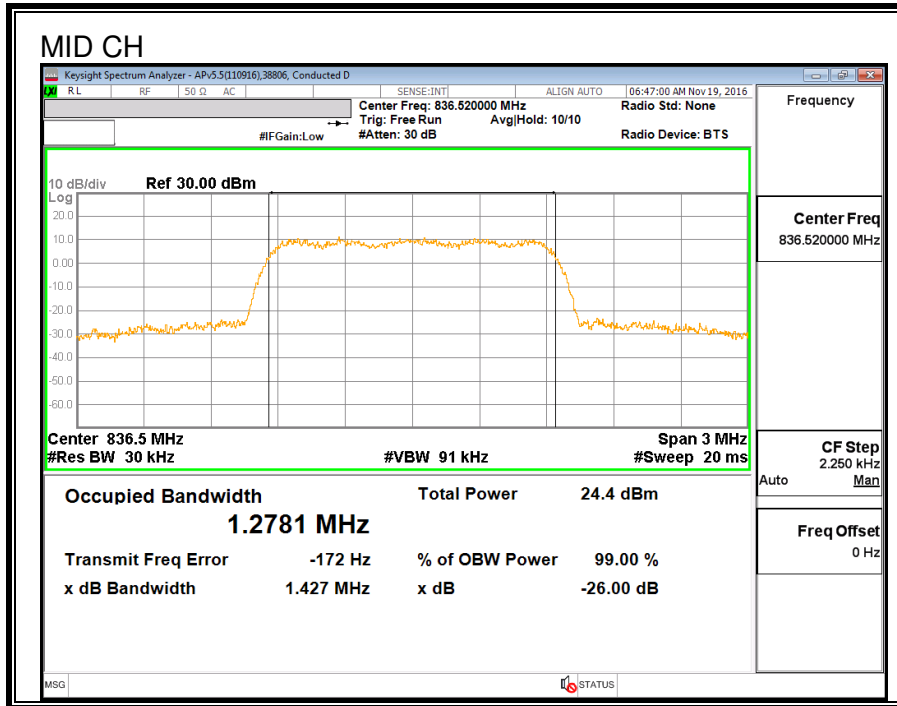

#### 1900MHz BAND

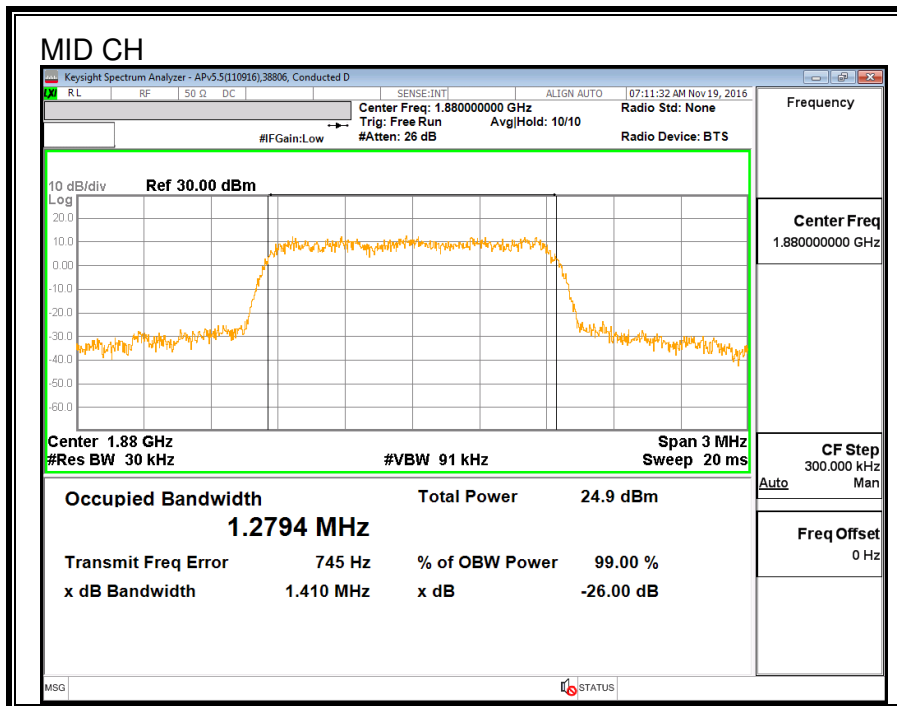

**800MHz SECONDARY BAND**

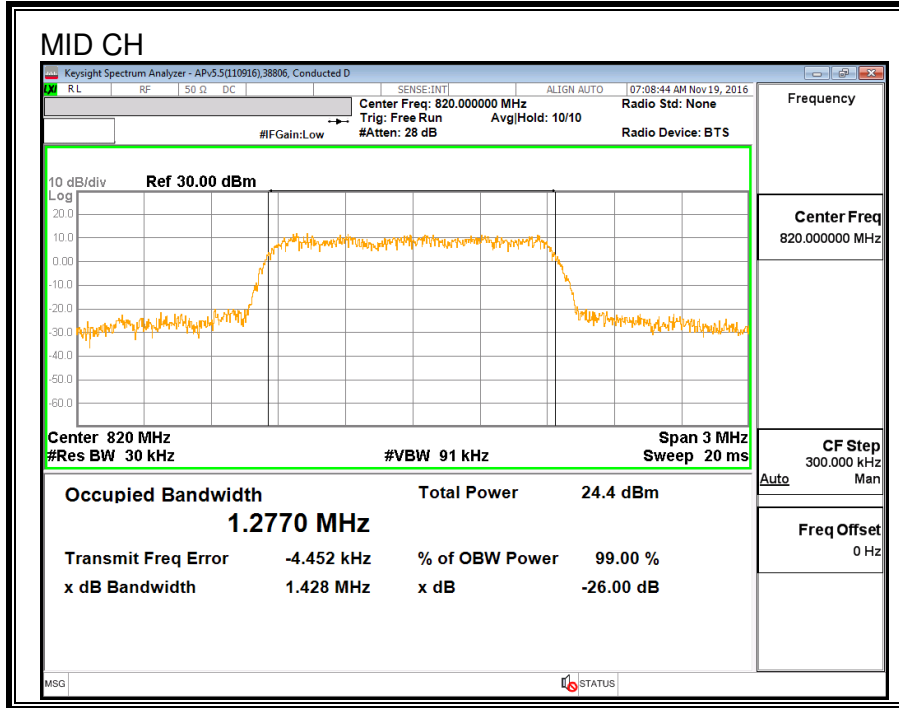

### 8.1.5. UMTS Rel99

#### 850MHz BAND

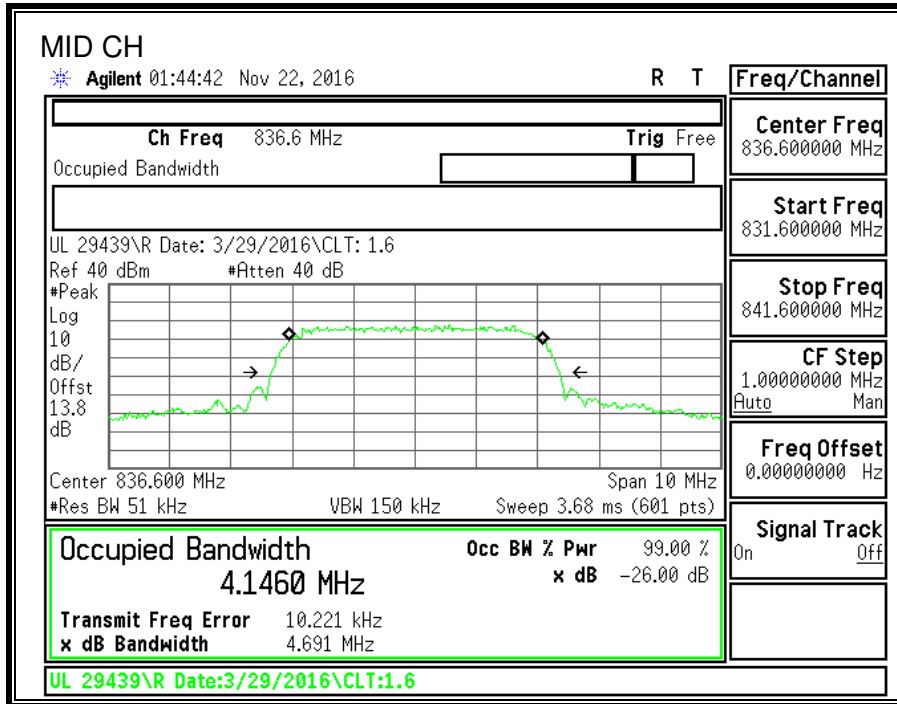

#### 1900MHz BAND

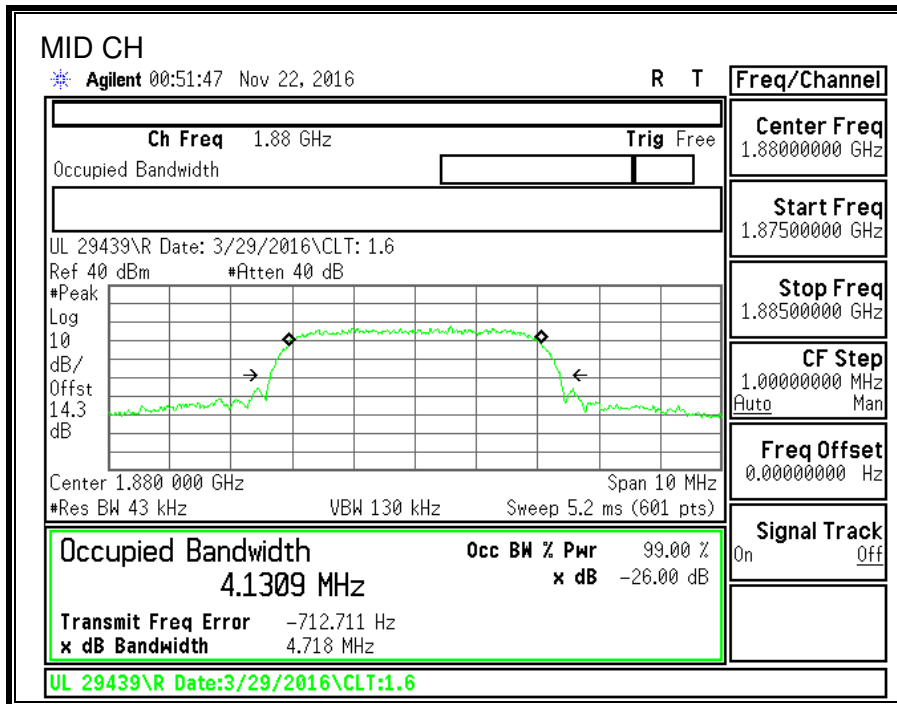

**1700MHz BAND**

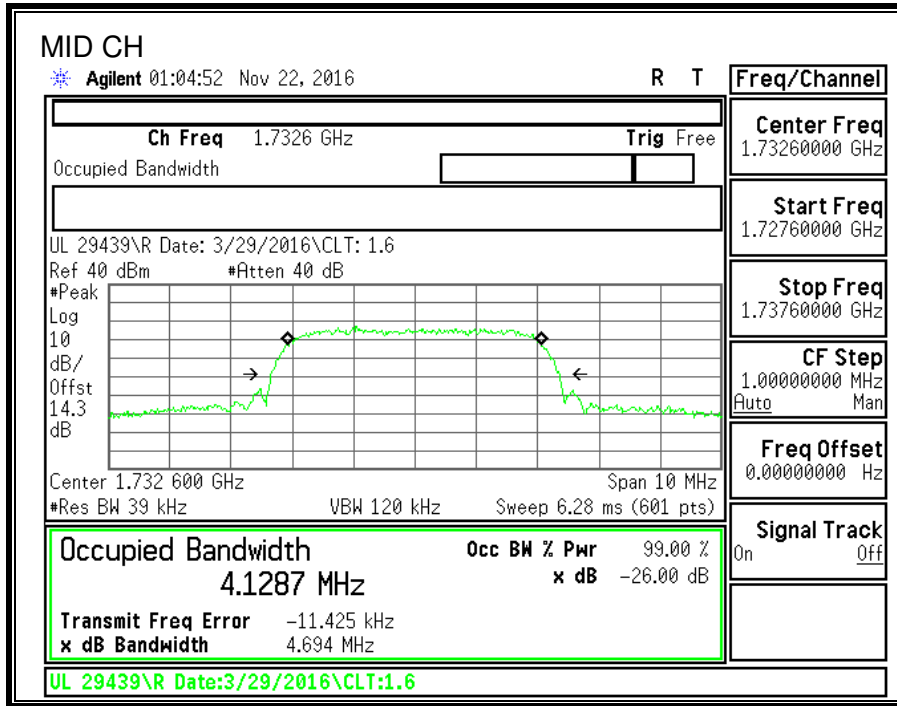

### 8.1.6. UMTS HSDPA

#### 850MHz BAND

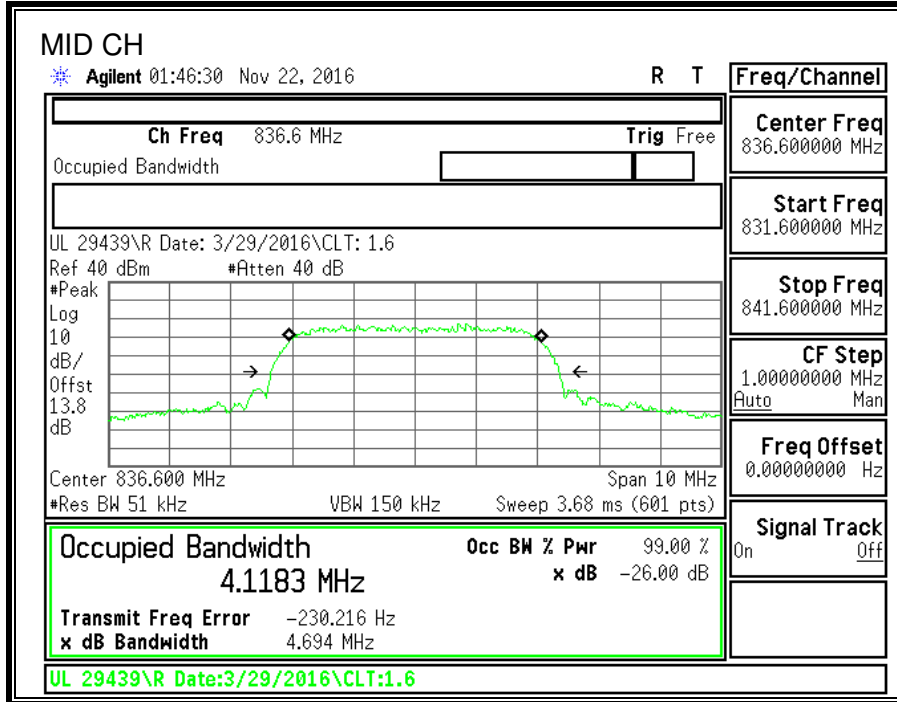

#### 1900MHz BAND

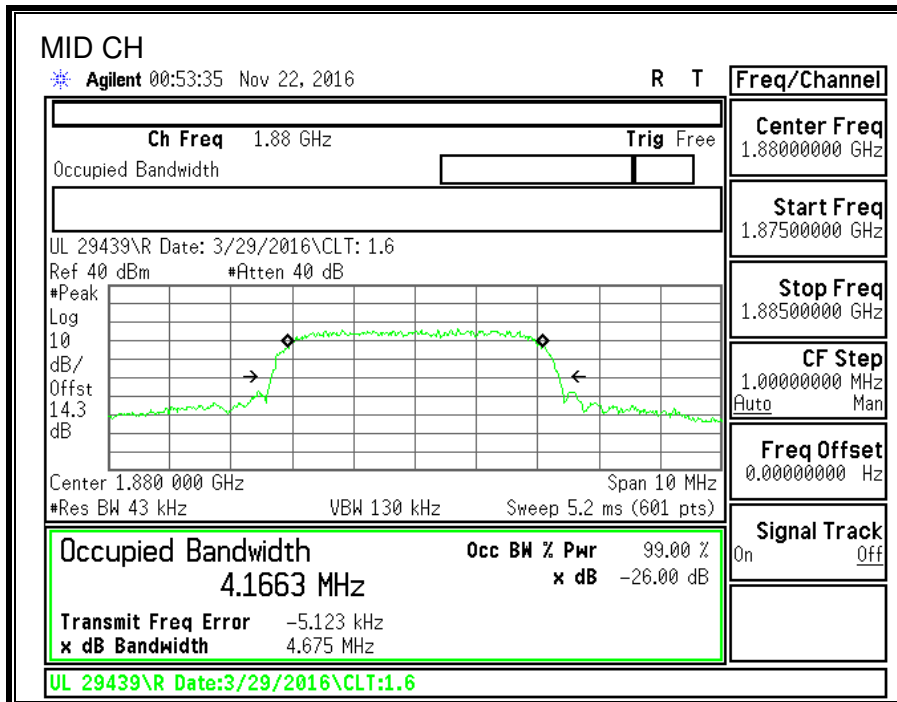

**1700MHz BAND**

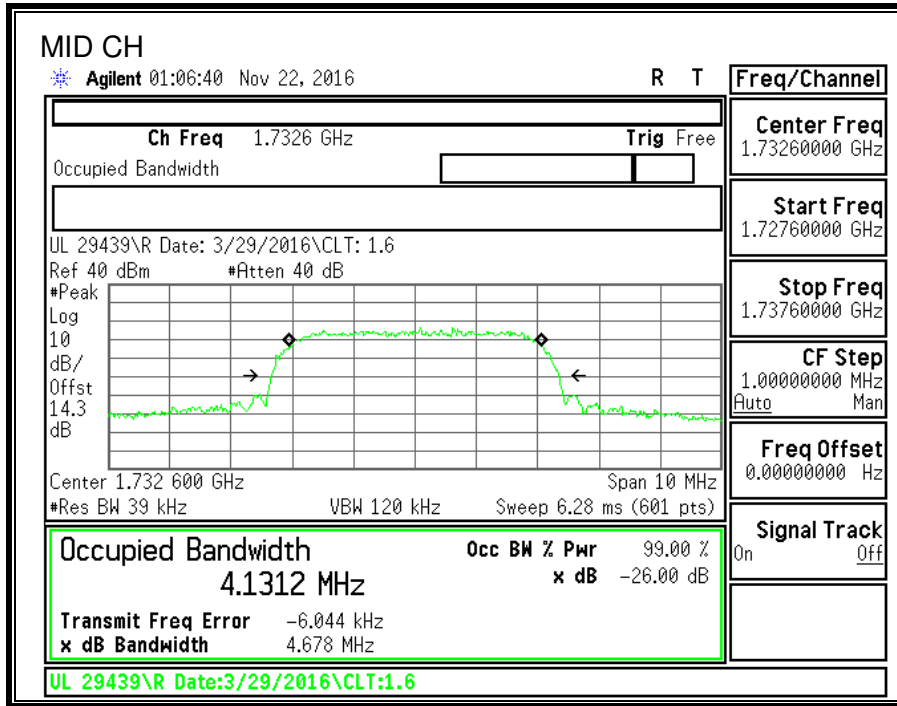

## 8.2. BAND EDGE

### RULE PART(S)

FCC: §2.1051, §22.359, §22.917, §24.238 and §90.691  
IC: RSS132§5.5; RSS133§6.5 and RSS139§6.6

### LIMITS

FCC: §22.359, §22.917, §24.238

The power of any emission outside of the authorized operating frequency ranges must be attenuated below the transmitting power (P) by a factor of at least  $43 + 10 \log (P)$  dB.

FCC: §27.53

(c) On any frequency outside the 776–788 MHz band, the power of any emission shall be attenuated outside the band below the transmitter power (P) by at least  $43 + 10 \log (P)$  dB;

(1) On any frequency outside the 746-758 MHz band, the power of any emission shall be attenuated outside the band below the transmitter power (P) by at least  $43 + 10 \log (P)$  dB;

(2) On any frequency outside the 776-788 MHz band, the power of any emission shall be attenuated outside the band below the transmitter power (P) by at least  $43 + 10 \log (P)$  dB;

(4) On all frequencies between 763-775 MHz and 793-805 MHz, by a factor not less than  $65 + 10 \log (P)$  dB in a 6.25 kHz band segment, for mobile and portable stations;

(5) Compliance with the provisions of paragraphs (c)(1) and (c)(2) of this section is based on the use of measurement instrumentation employing a resolution bandwidth of 100 kHz or greater.

However, in the 100 kHz bands immediately outside and adjacent to the frequency block, a resolution bandwidth of at least 30 kHz may be employed;

(6) Compliance with the provisions of paragraphs (c)(3) and (c)(4) of this section is based on the use of measurement instrumentation such that the reading taken with any resolution bandwidth setting should be adjusted to indicate spectral energy in a 6.25 kHz segment.

FCC: §90.691 Emission mask requirements for EA-based systems.

(a) Out-of-band emission requirement shall apply only to the “outer” channels included in an EA license and to spectrum adjacent to interior channels used by incumbent licensees. The emission limits are as follows:

(1) For any frequency removed from the EA licensee's frequency block by up to and including 37.5 kHz, the power of any emission shall be attenuated below the transmitter power (P) in watts by at least  $116 \log_{10}(f/6.1)$  decibels or  $50 + 10 \log_{10}(P)$  decibels or 80 decibels, whichever is the lesser attenuation, where f is the frequency removed from the center of the outer channel in the block in kilohertz and where f is greater than 12.5 kHz.

(2) For any frequency removed from the EA licensee's frequency block greater than 37.5 kHz, the power of any emission shall be attenuated below the transmitter power (P) in watts by at least  $43 + 10 \log_{10}(P)$  decibels or 80 decibels, whichever is the lesser attenuation, where f is the frequency removed from the center of the outer channel in the block in kilohertz and where f is greater than 37.5 kHz.

(b) When an emission outside of the authorized bandwidth causes harmful interference, the Commission may, at its discretion, require greater attenuation than specified in this section.

### **RSS132§5.5**

Mobile and base station equipment shall comply with the limits in (i) and (ii) below.

In the first 1.0 MHz band immediately outside and adjacent to each of the sub-bands specified in Section 5.1, the power of emissions per any 1% of the occupied bandwidth shall be attenuated (in dB) below the transmitter output power  $P$  ( dBW) by at least  $43 + 10 \log_{10} p$  (watts).

After the first 1.0 MHz immediately outside and adjacent to each of the sub-bands, the power of emissions in any 100 kHz bandwidth shall be attenuated (in dB) below the transmitter output power  $P$  (dBW) by at least  $43 + 10 \log_{10} p$  (watts). If the measurement is performed using 1% of the occupied bandwidth, power integration over 100 kHz is required.

### **RSS133§6.5**

Equipment shall comply with the limits in (i) and (ii) below.

(i) In the 1.0 MHz bands immediately outside and adjacent to the equipment's operating frequency block, the emission power per any 1% of the emission bandwidth shall be attenuated (in dB) below the transmitter output power  $P$  (dBW) by at least  $43 + 10 \log_{10} p$  (watts).

(ii) After the first 1.0 MHz, the emission power in any 1 MHz bandwidth shall be attenuated (in dB) below the transmitter output power  $P$  (dBW) by at least  $43 + 10 \log_{10} p$  (watts). If the measurement is performed using 1% of the emission bandwidth, power integration over 1.0 MHz is required.

### **RSS139§6.6**

(i) In the first 1.0 MHz bands immediately outside and adjacent to the equipment's smallest operating frequency block, Footnote 2 which can contain the equipment's occupied bandwidth, the emission power per any 1% of the emission bandwidth shall be attenuated below the transmitter output power  $P$  (in dBW) by at least  $43 + 10 \log_{10} p$  (watts) dB.

(ii) After the first 1.0 MHz outside the equipment's smallest operating frequency block, which can contain the equipment's occupied bandwidth, the emission power in any 1 MHz bandwidth shall be attenuated below the transmitter output power  $P$  (in dBW) by at least  $43 + 10 \log_{10} p$  (watts) dB.

## **TEST PROCEDURE**

The transmitter output was connected to a Agilent 8960 Test Set and configured to operate at maximum power. The band edge emissions were measured at the required operating frequencies in each band on the Spectrum Analyzer.

For each band edge measurement:

- Set the spectrum analyzer span to include the block edge frequency.
- Set a marker to point the corresponding band edge frequency in each test case.
- Set display line at -13 dBm
- Set resolution bandwidth to at least 1% of emission bandwidth.

## **RESULTS**

### 8.2.1. GSM GPRS

#### 850MHz BAND

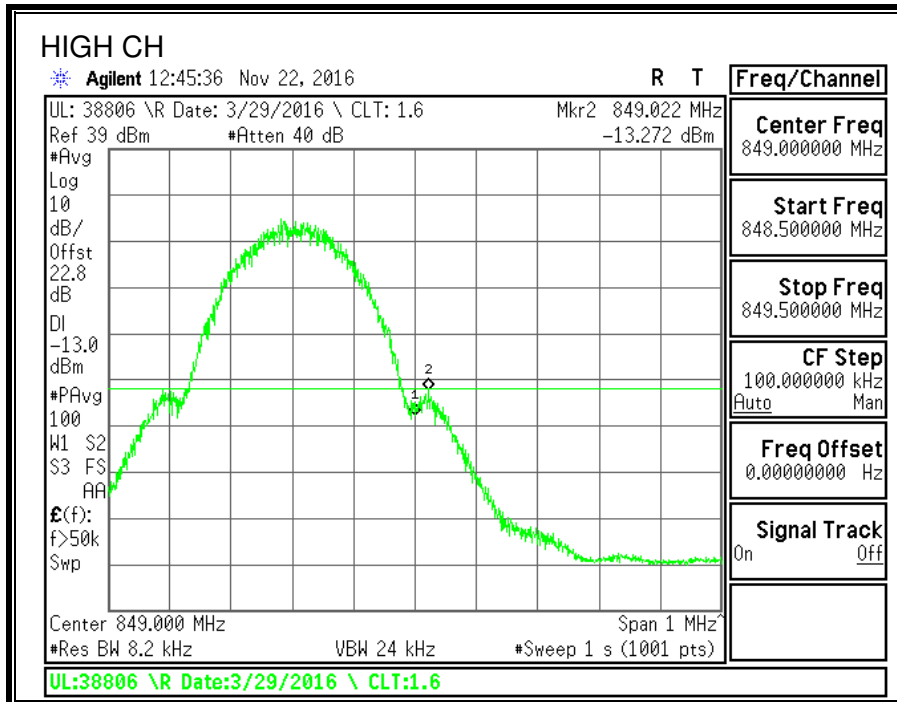
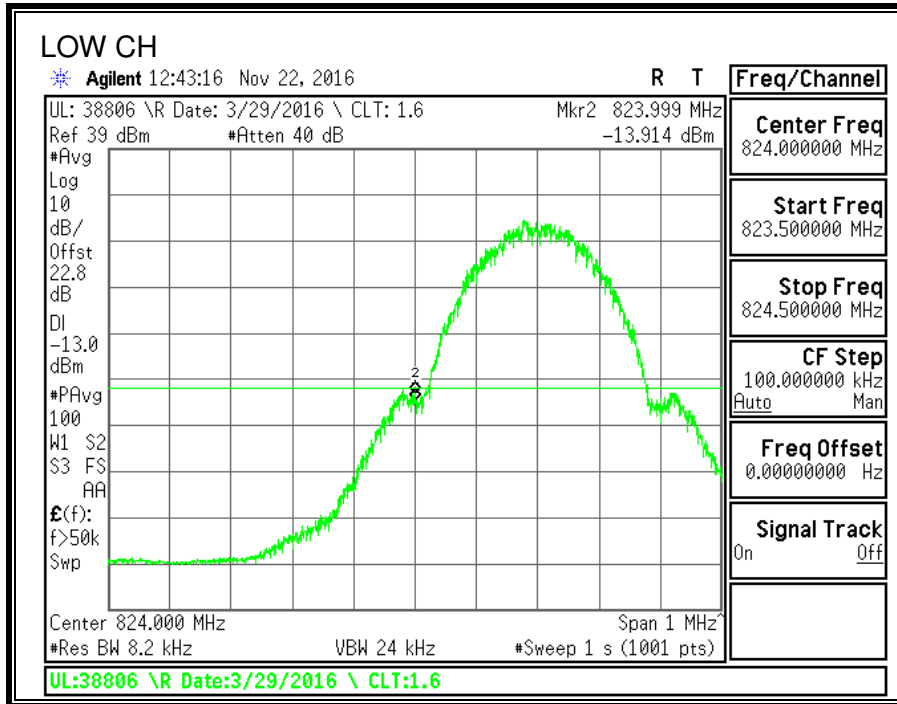

**1900MHz BAND**

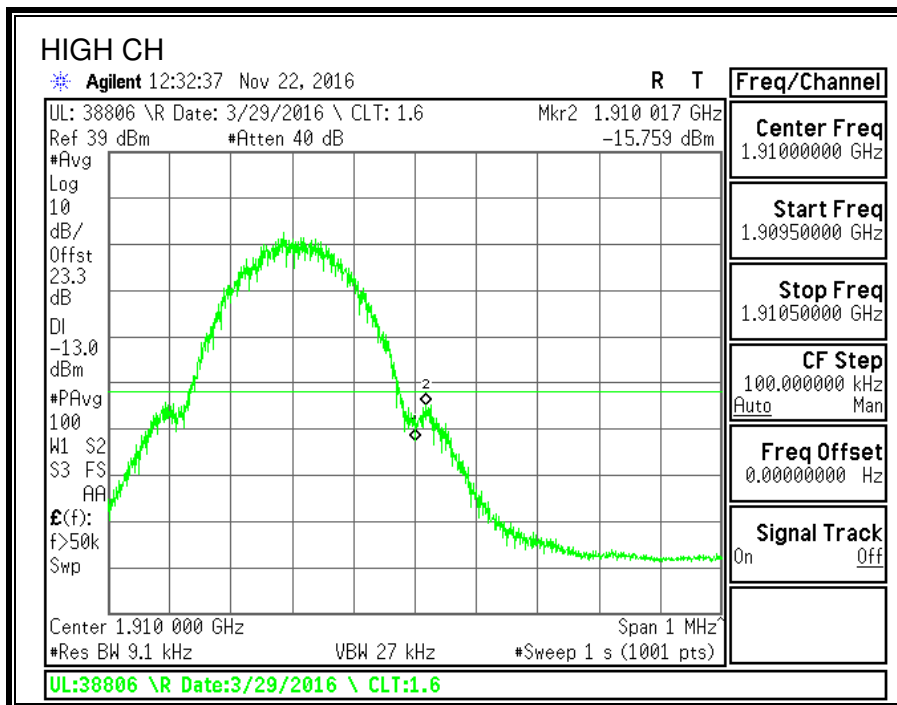
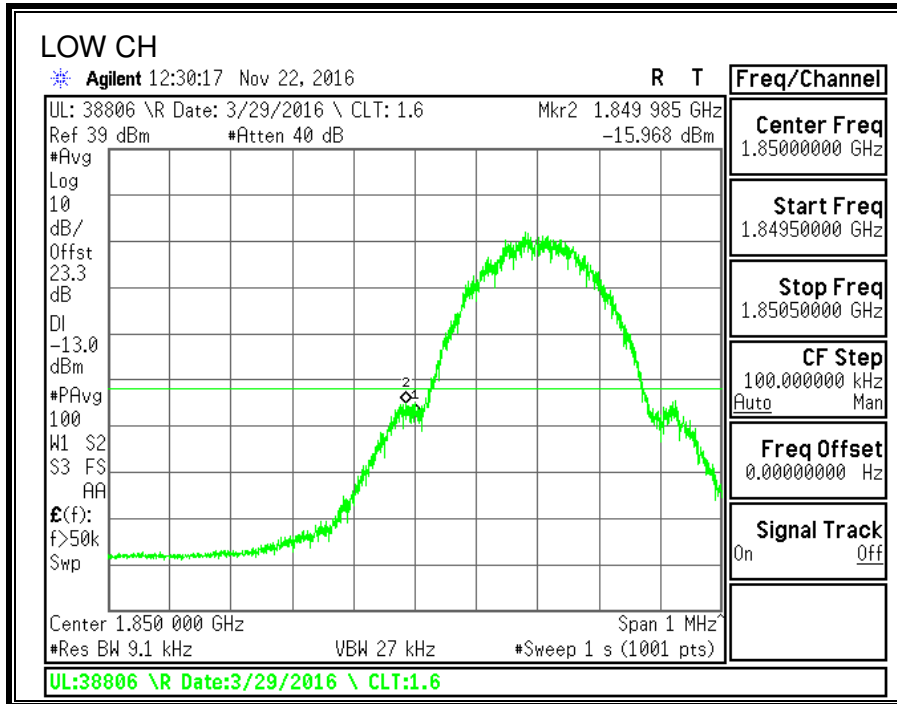

### 8.2.2. GSM EGPRS

#### 850MHz BAND

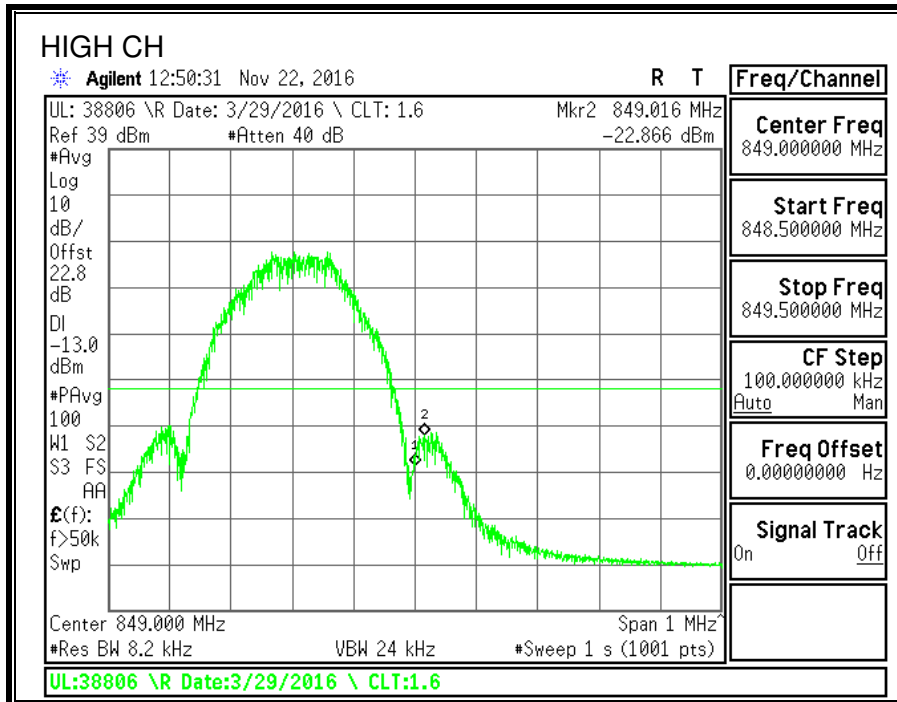
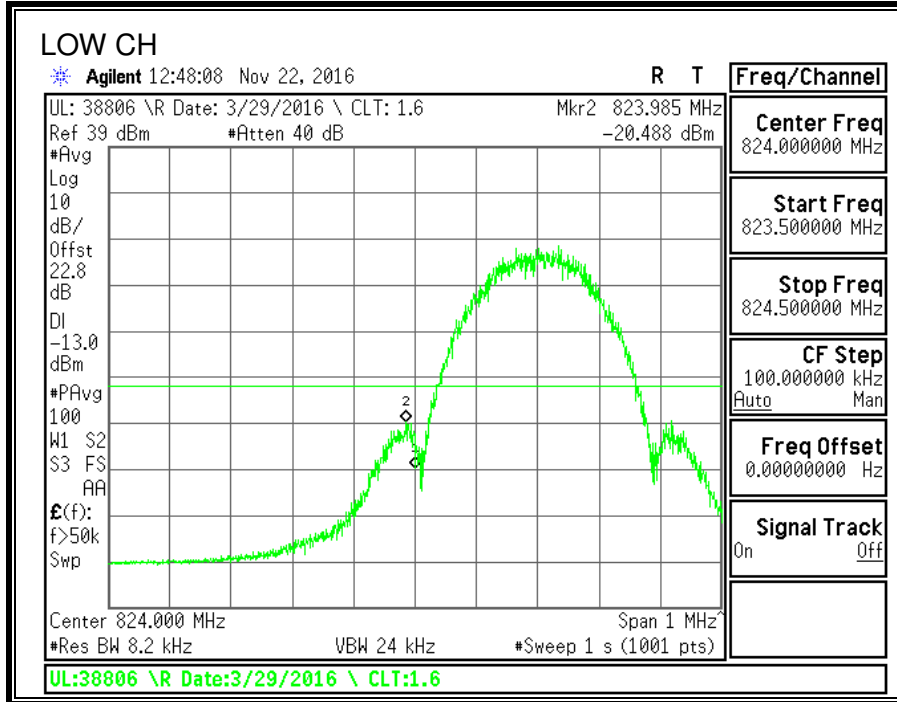

**1900MHz BAND**

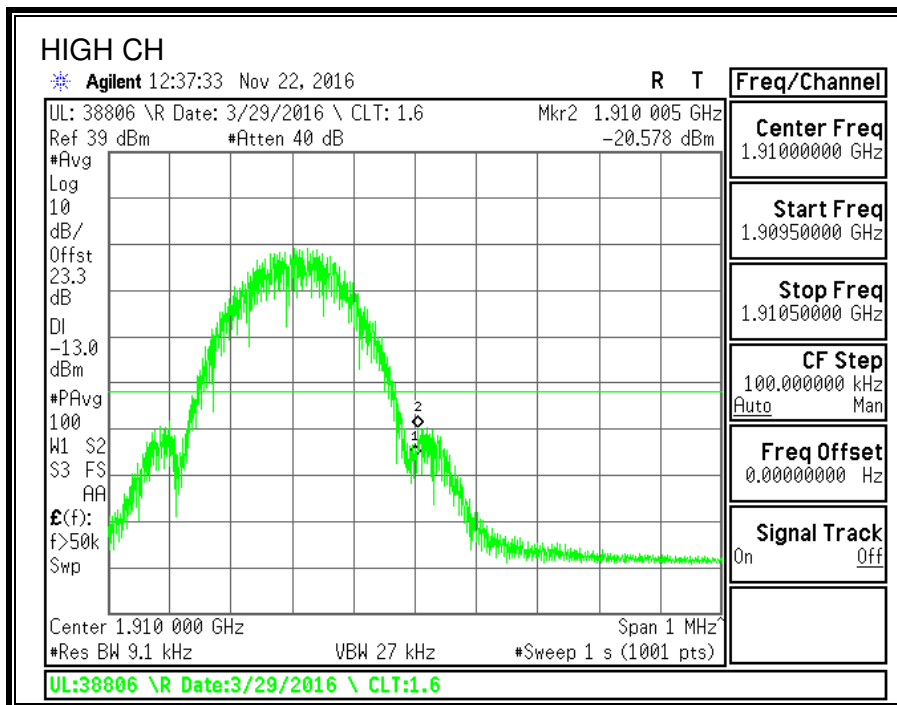
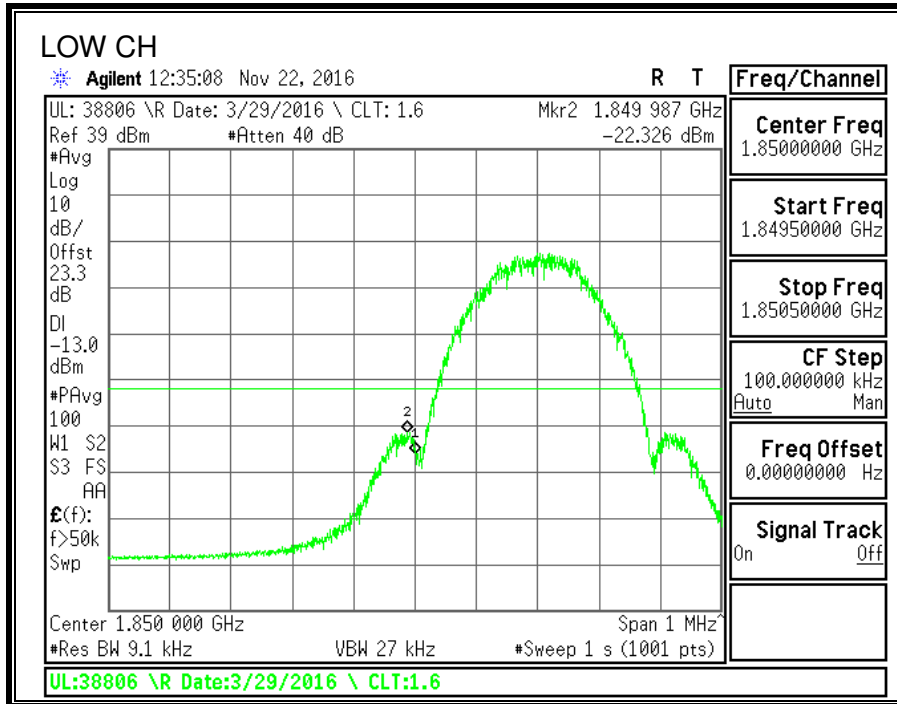

### 8.2.3. CDMA2000 1xRTT

#### 850MHz BAND

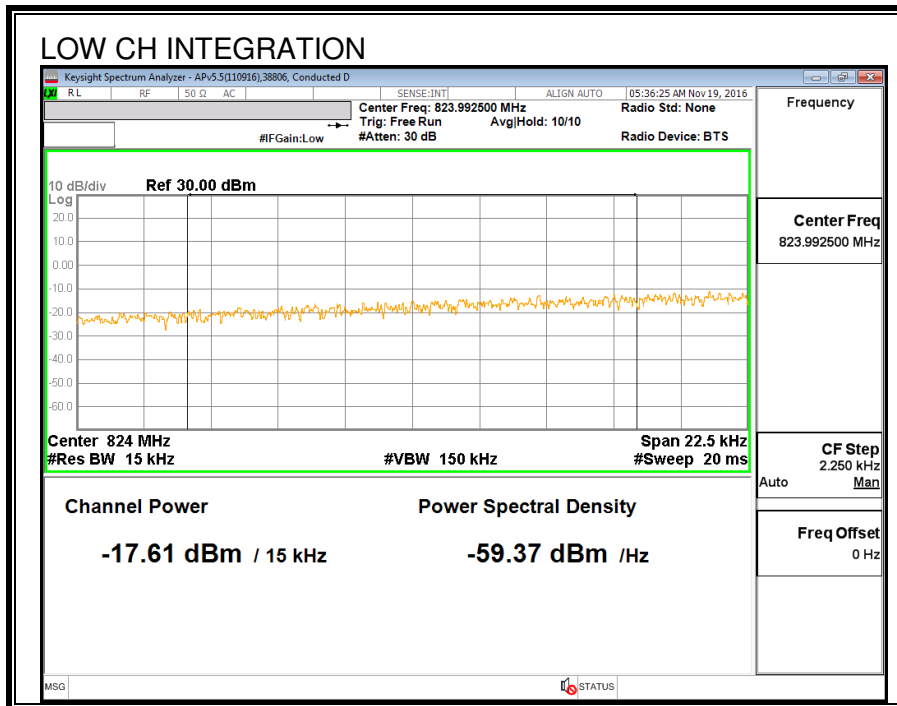
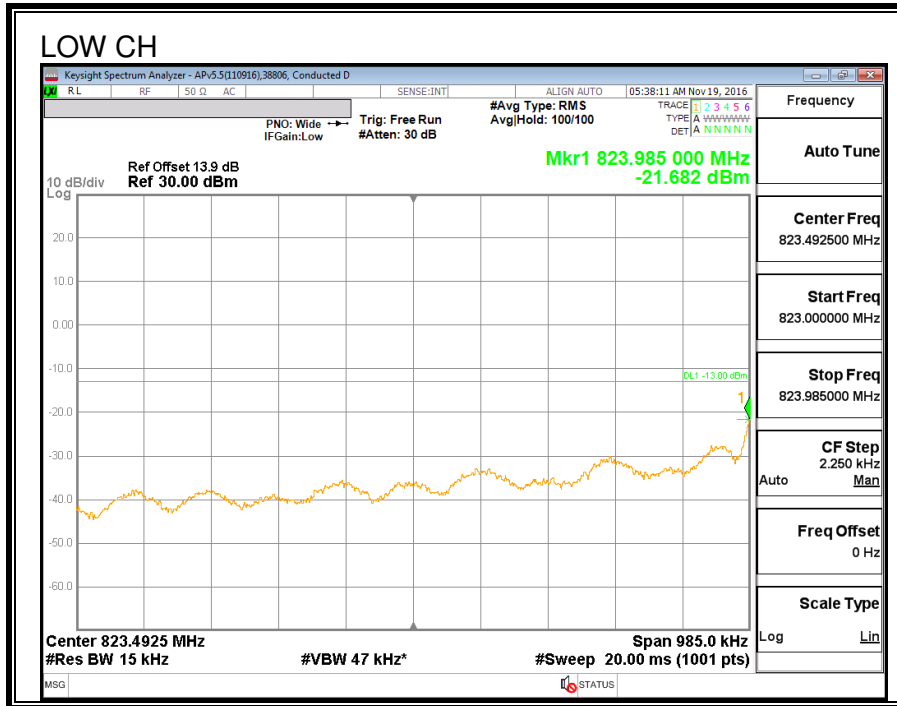

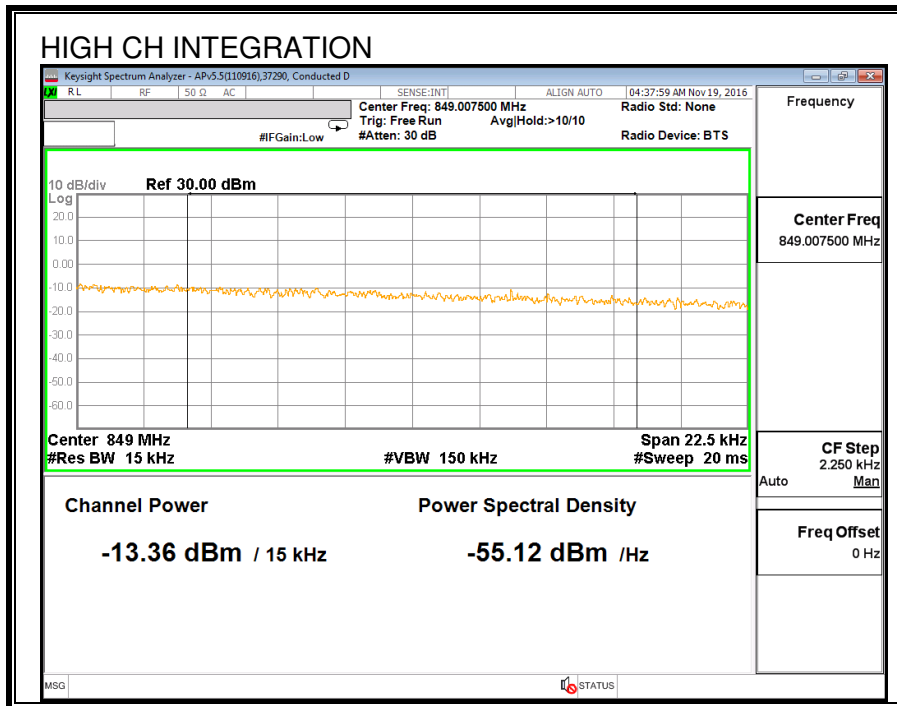
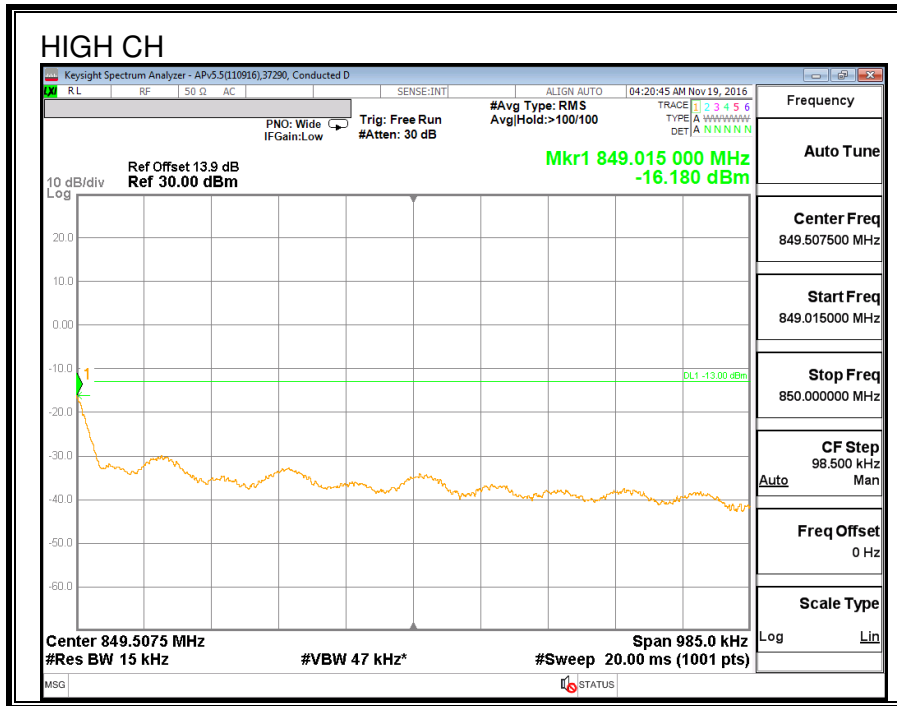

**1900MHz BAND**

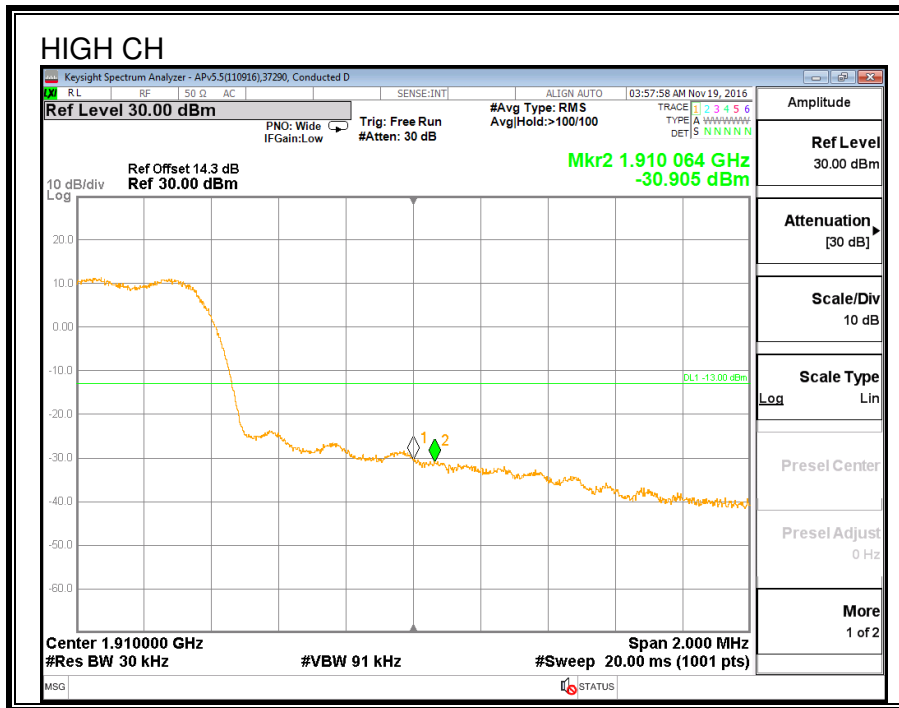
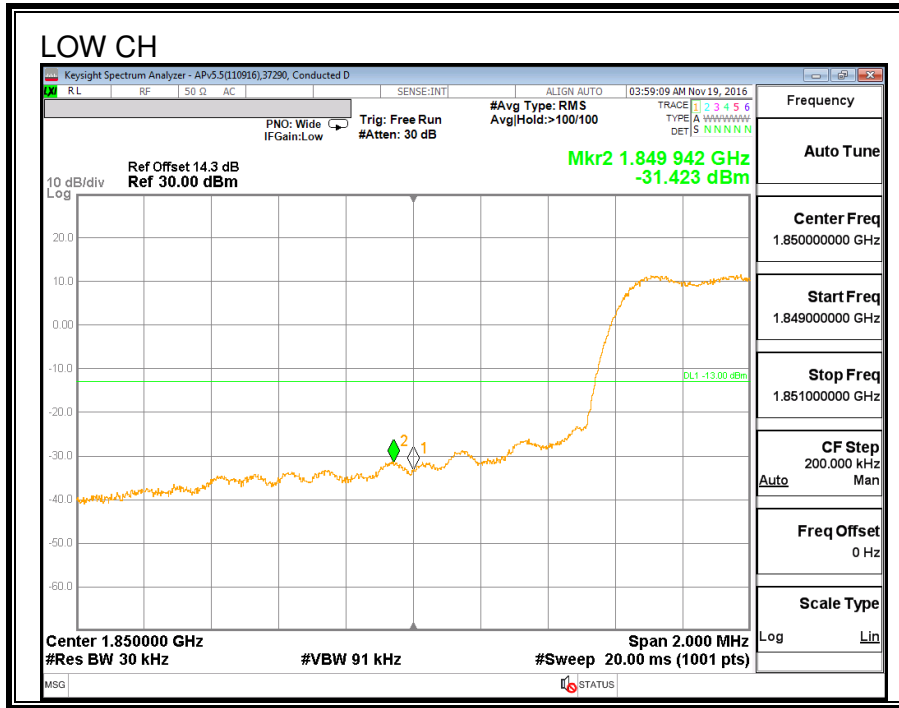

### 8.2.4. CDMA2000 1xRTT BC10 MASK

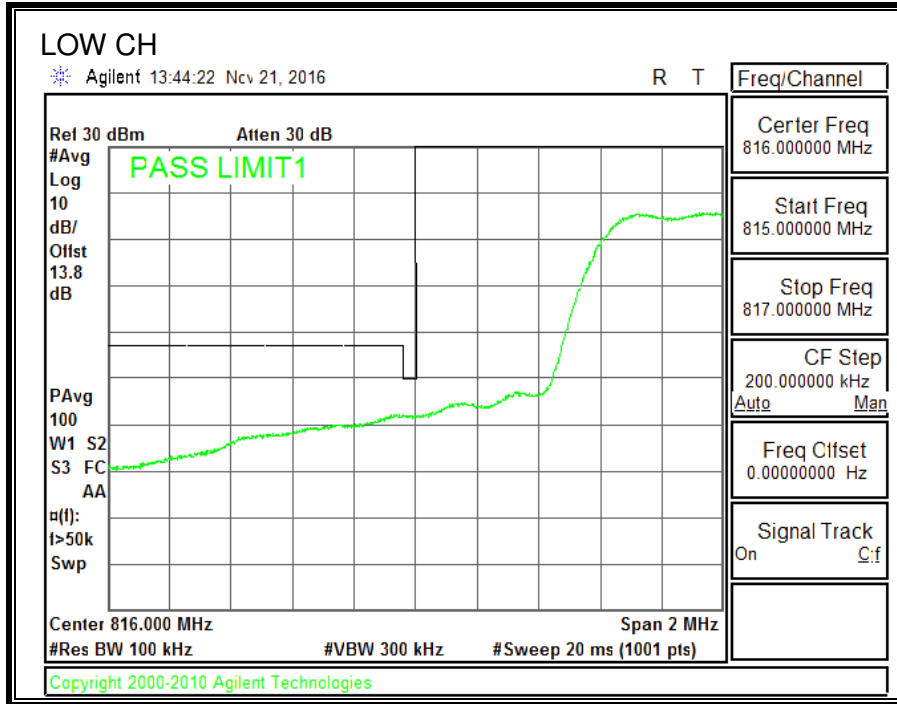

Note: RBW=1% of EBW

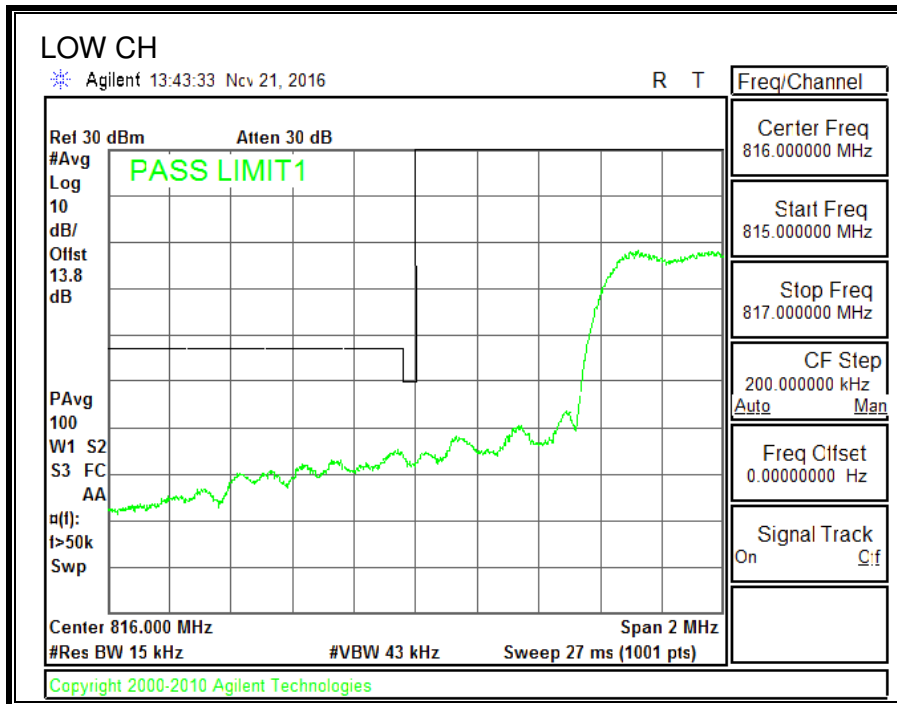

Note: RBW=1% of 37.5KHz of outer channel frequency block.

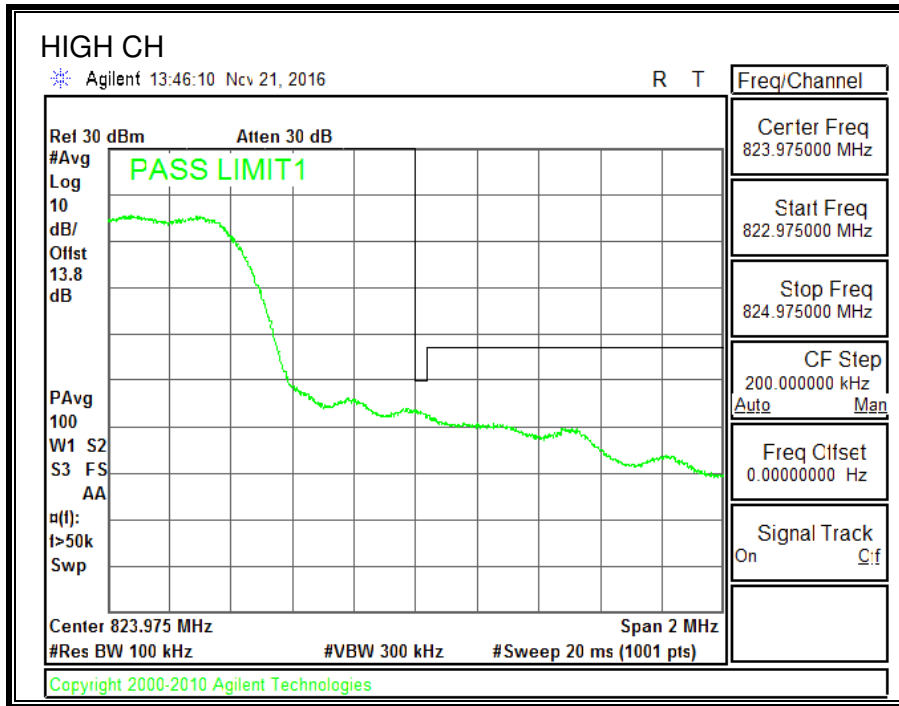

Note: RBW=1% of EBW

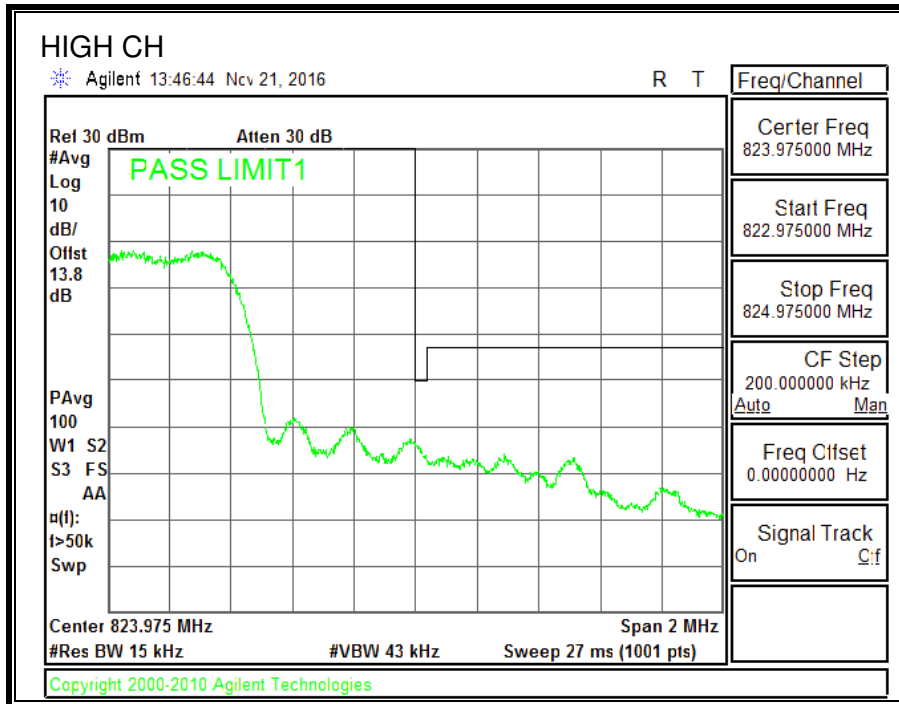

Note: RBW=1% of 37.5KHz of outer channel frequency block.

### 8.2.5. CDMA2000 EVDO REV A

#### 850MHz BAND

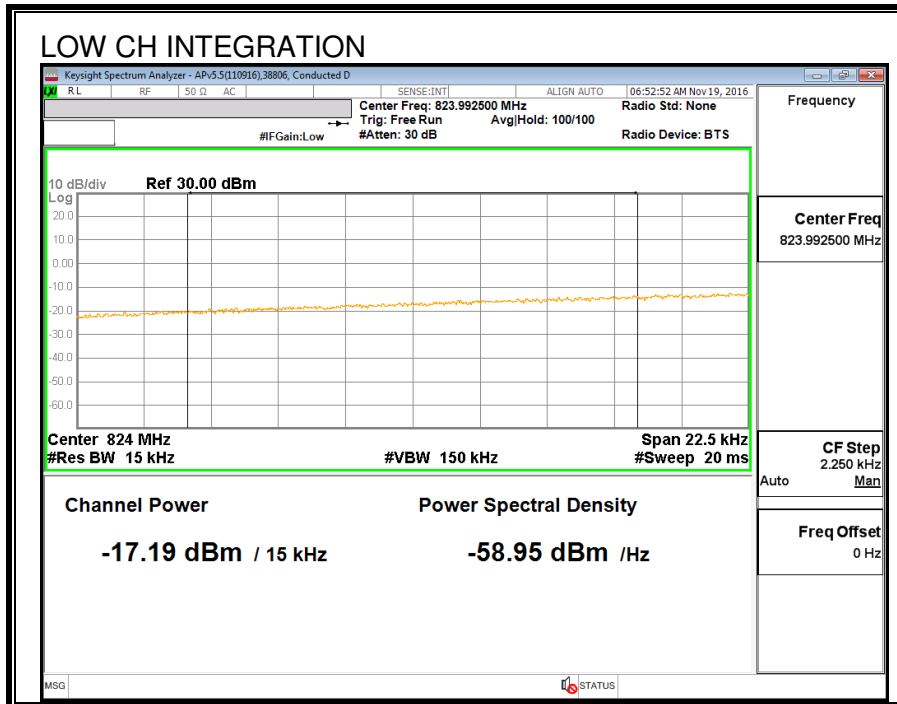
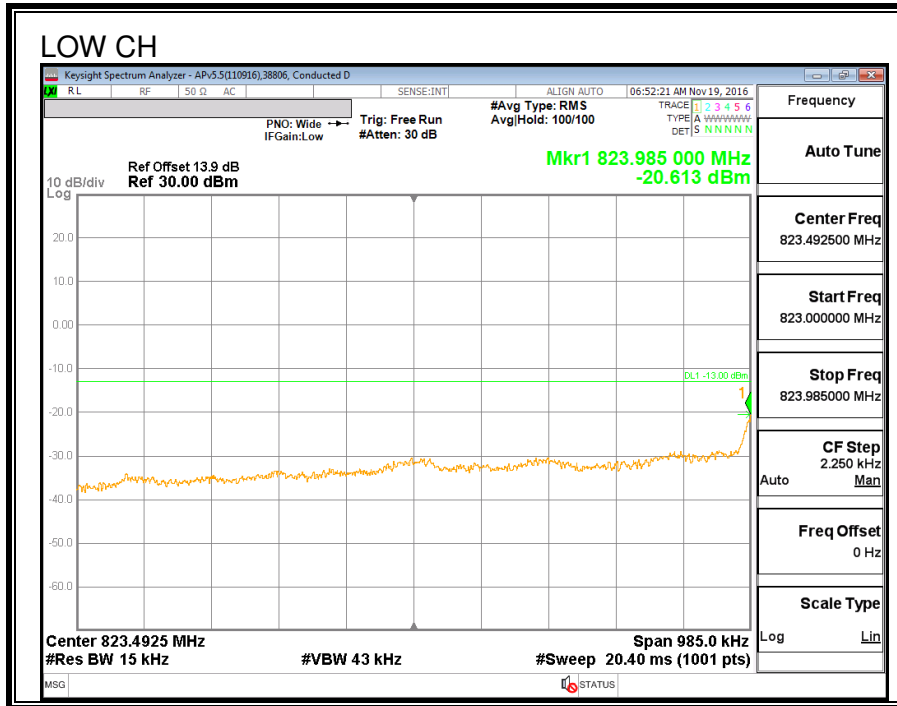

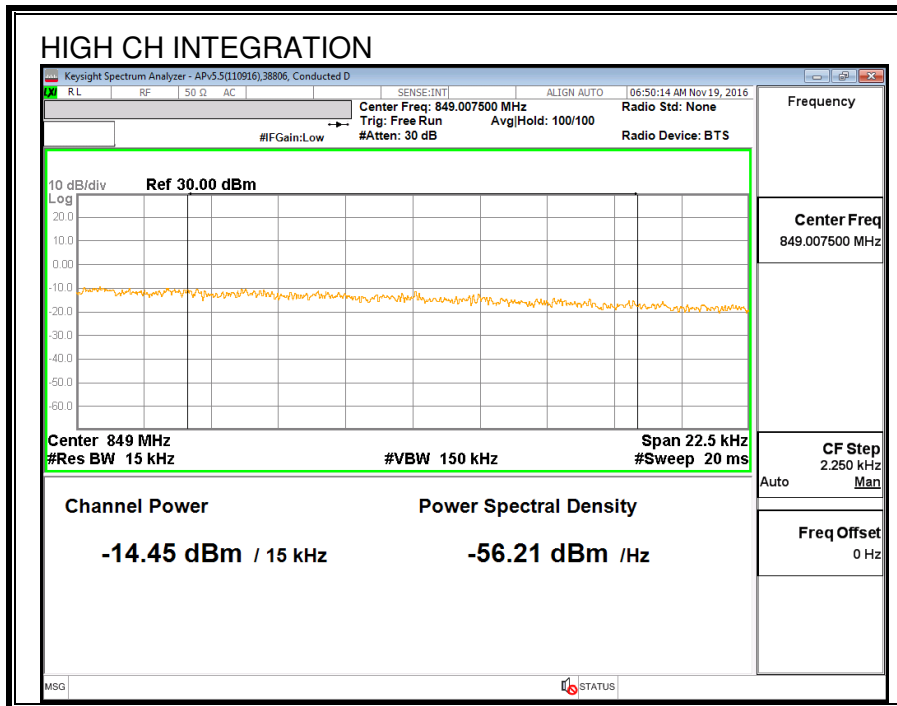
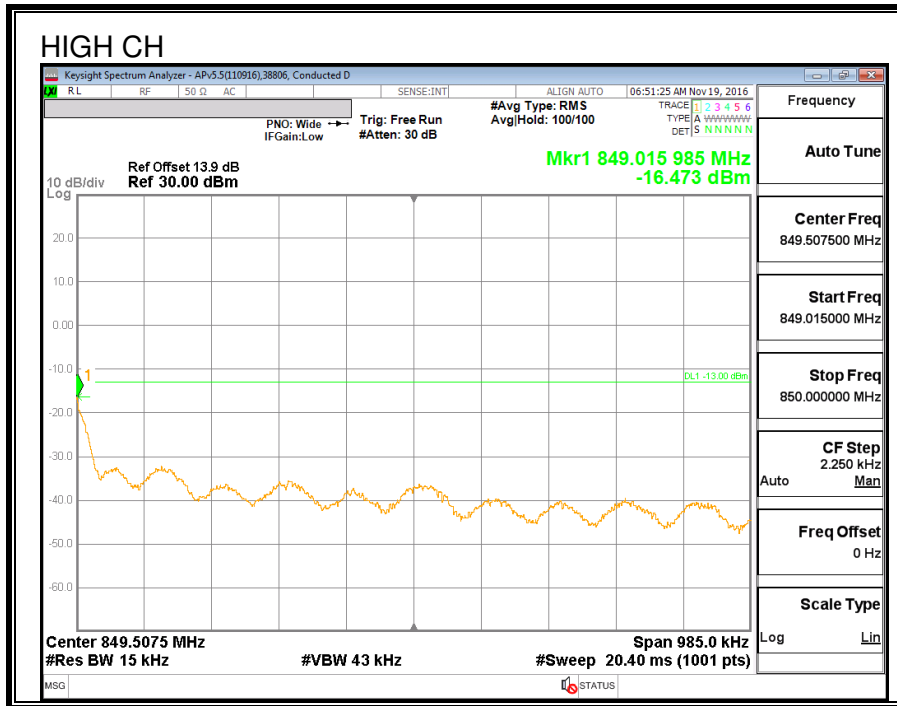

**1900MHz BAND**

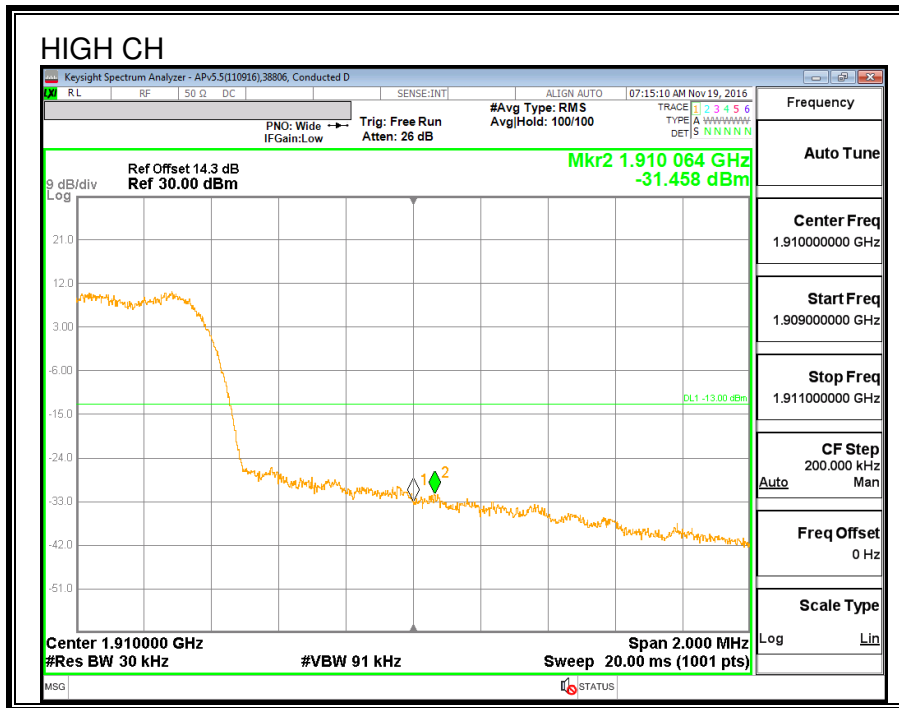
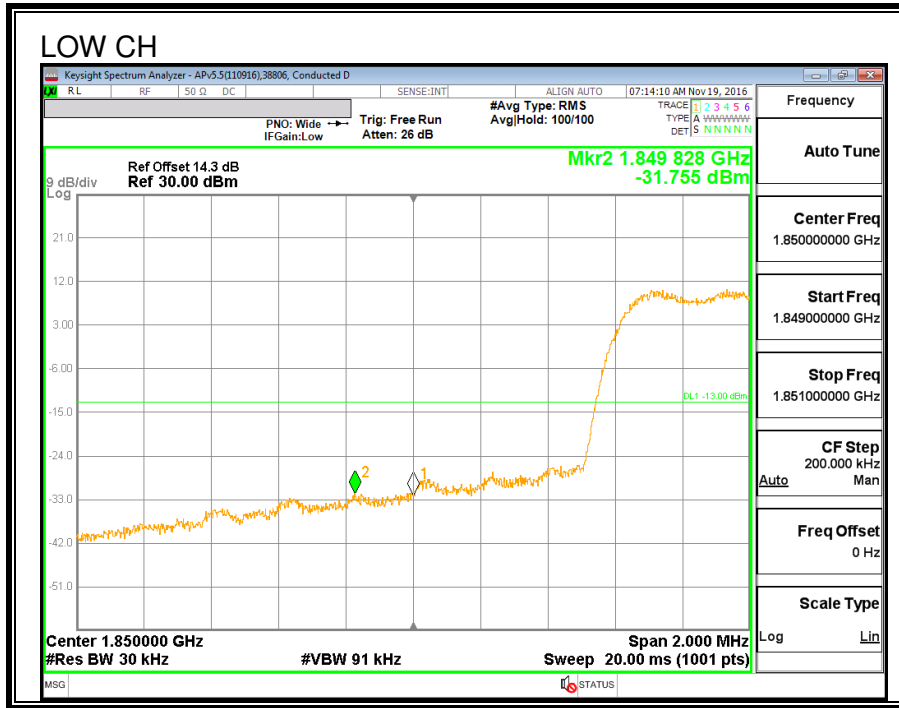

### 8.2.6. CDMA2000 EVDO REV A BC10 MASK

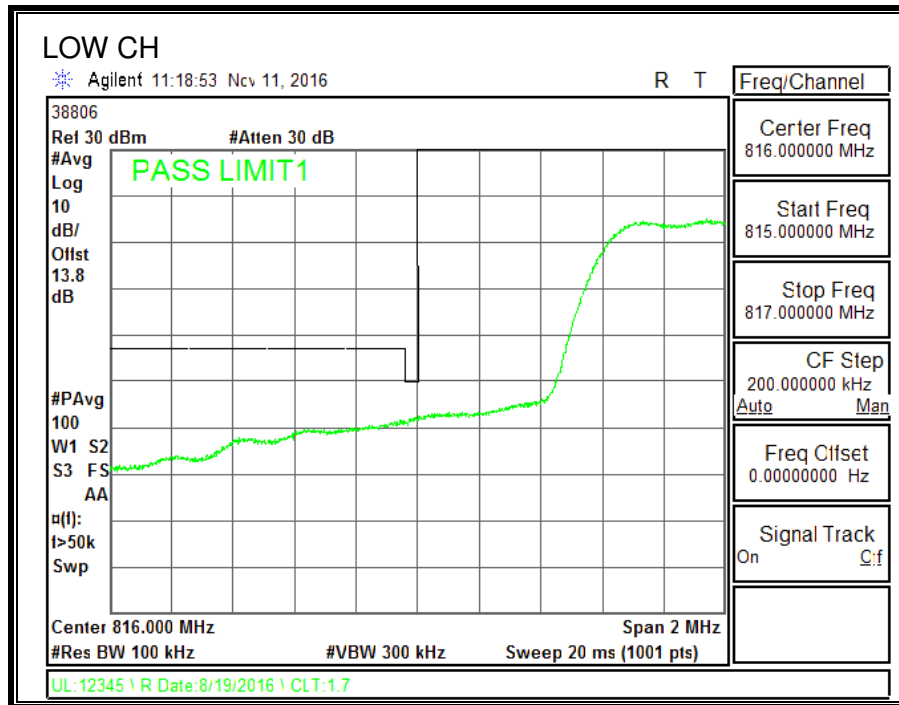

Note: RBW=1% of EBW

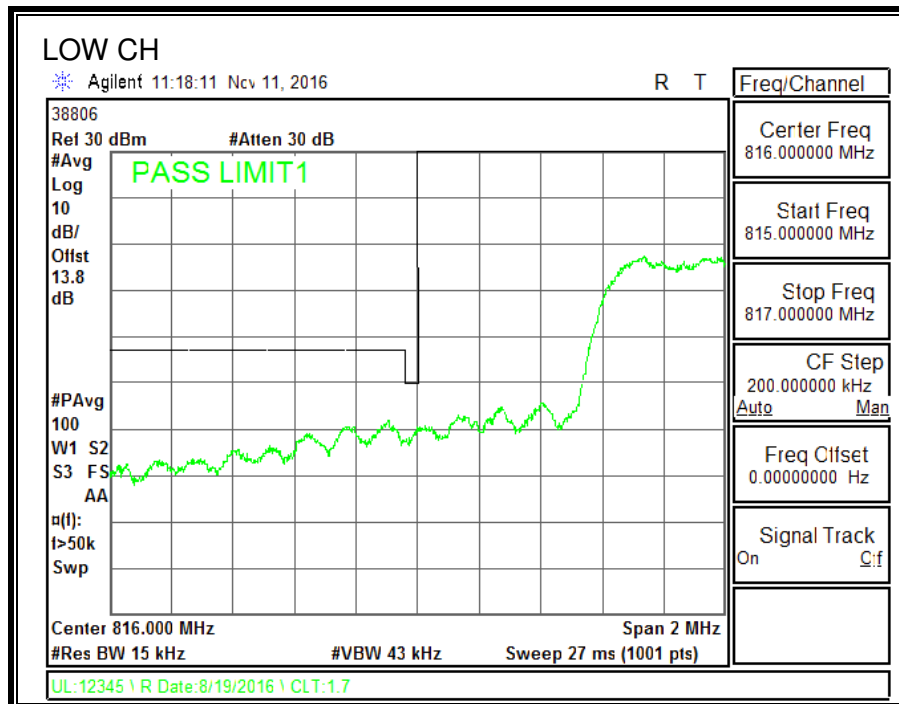

Note: RBW=1% of 37.5KHz of outer channel frequency block.

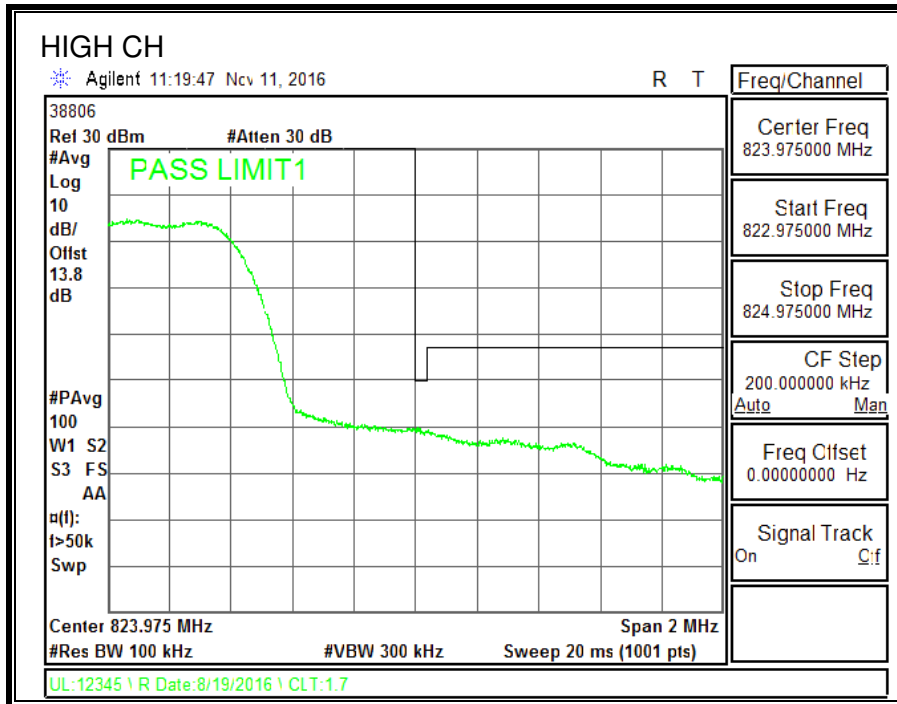

Note: RBW=1% of EBW

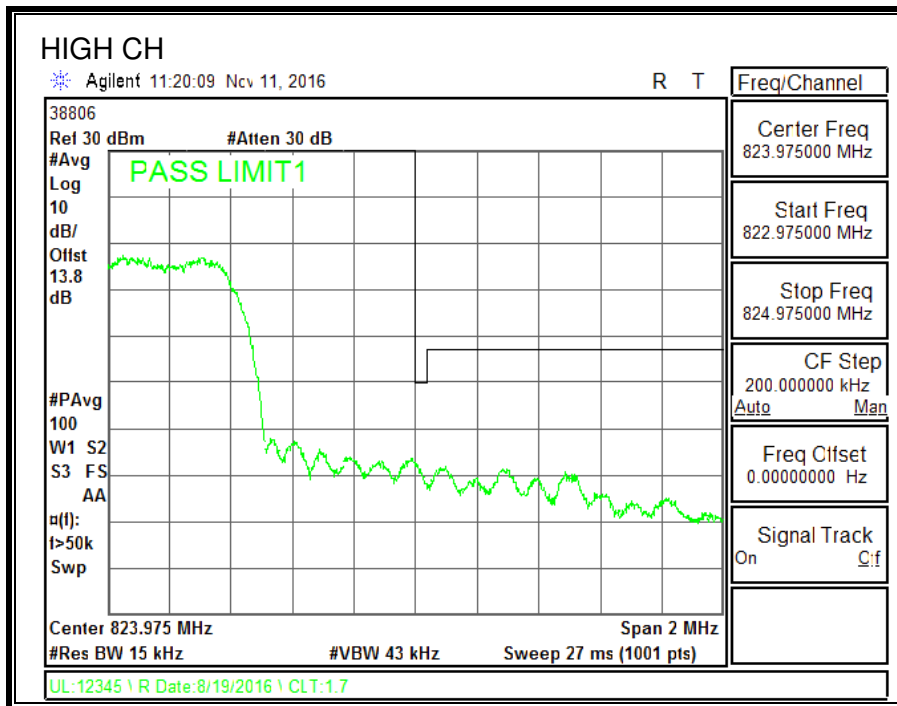

Note: RBW=1% of 37.5KHz of outer channel frequency block.

### 8.2.7. UMTS Rel99

#### 850MHz BAND

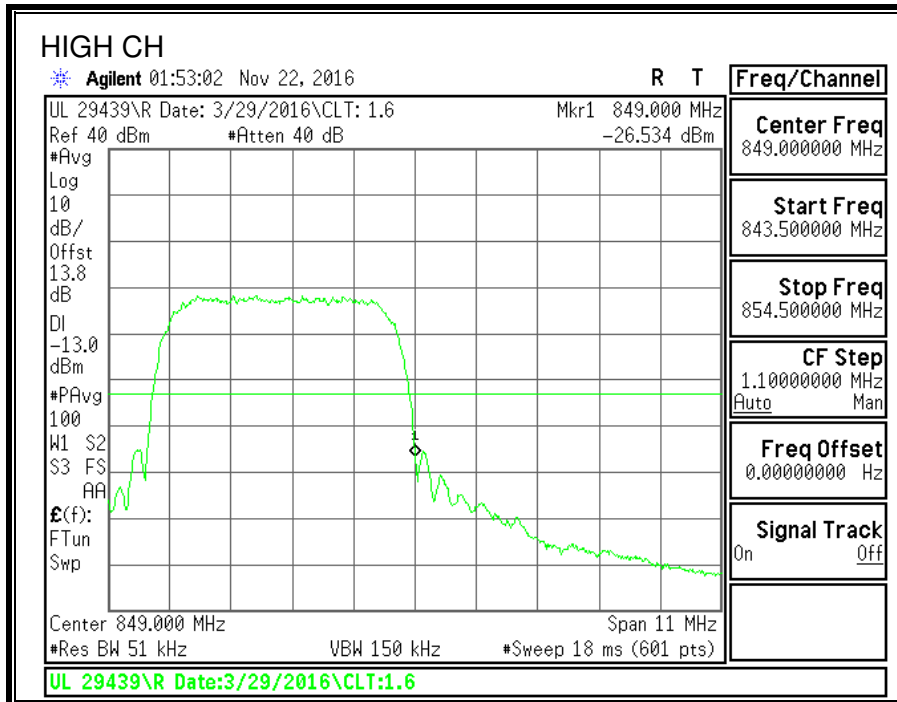
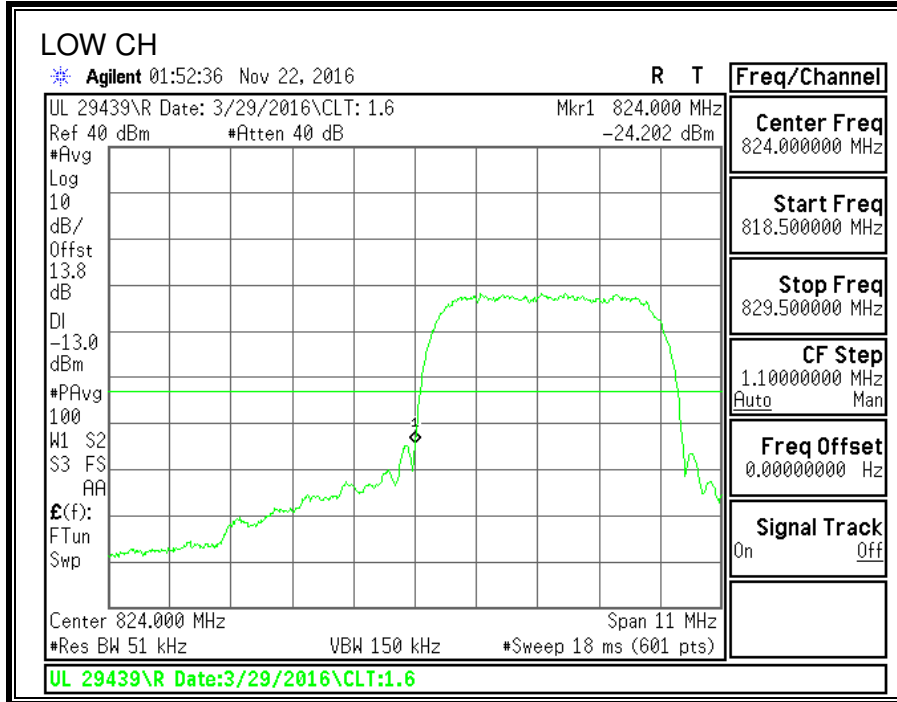

**1900MHz BAND**

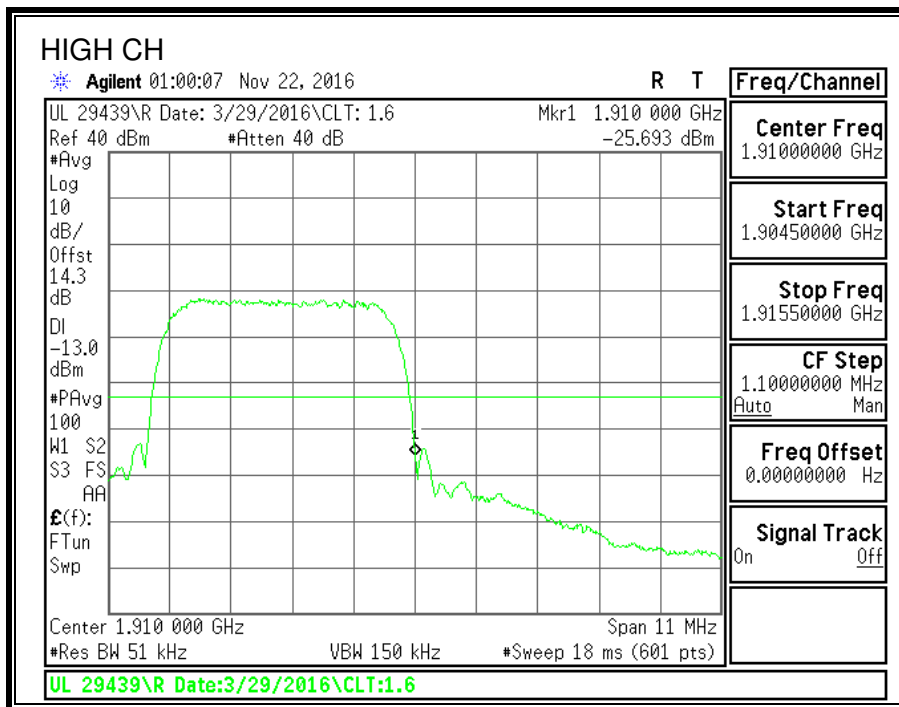
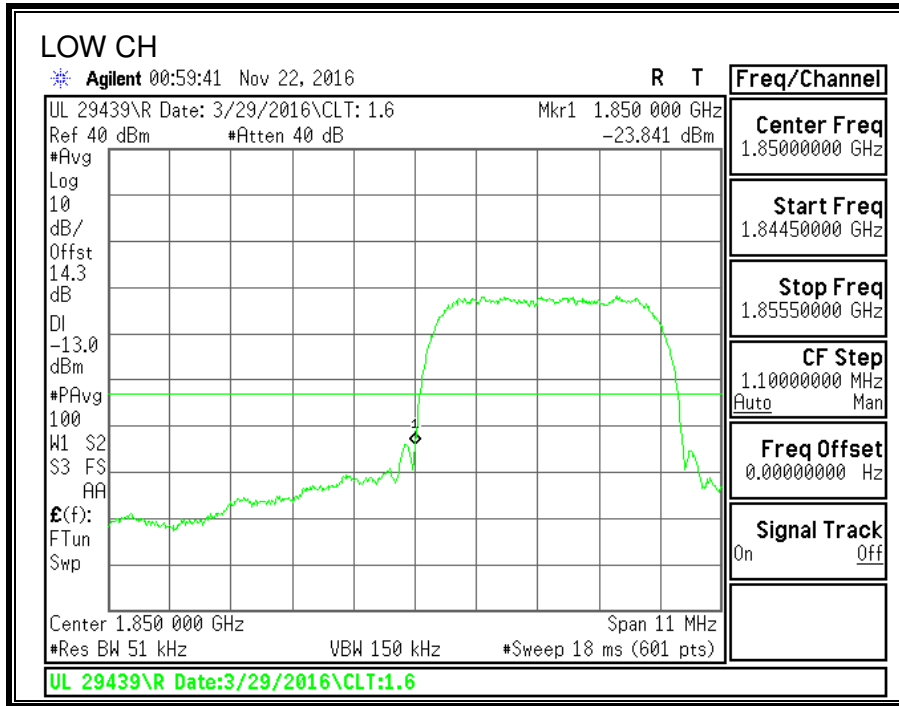

**1700MHz BAND**

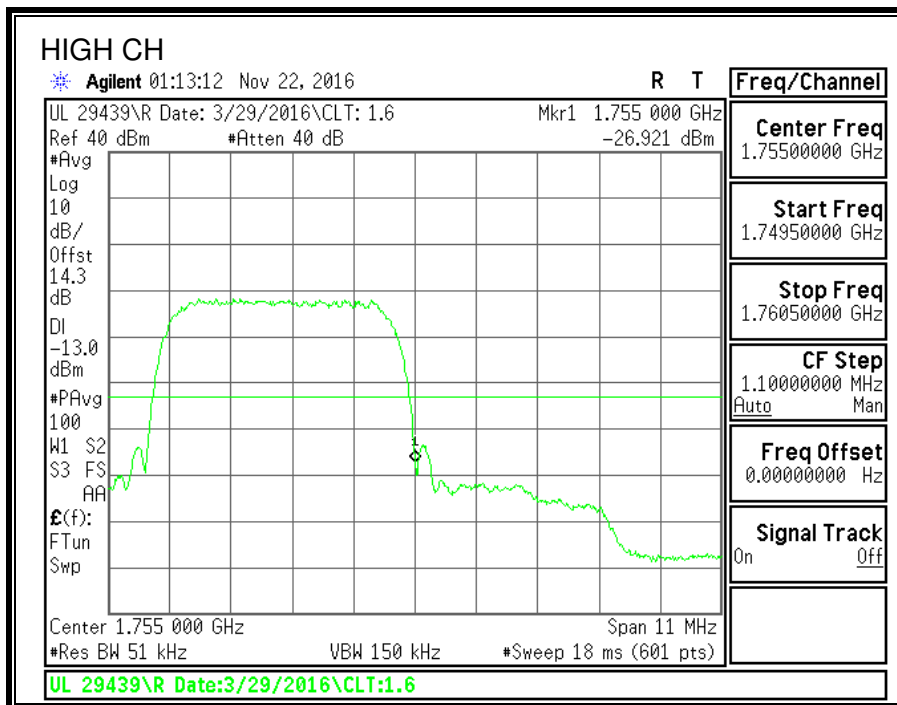
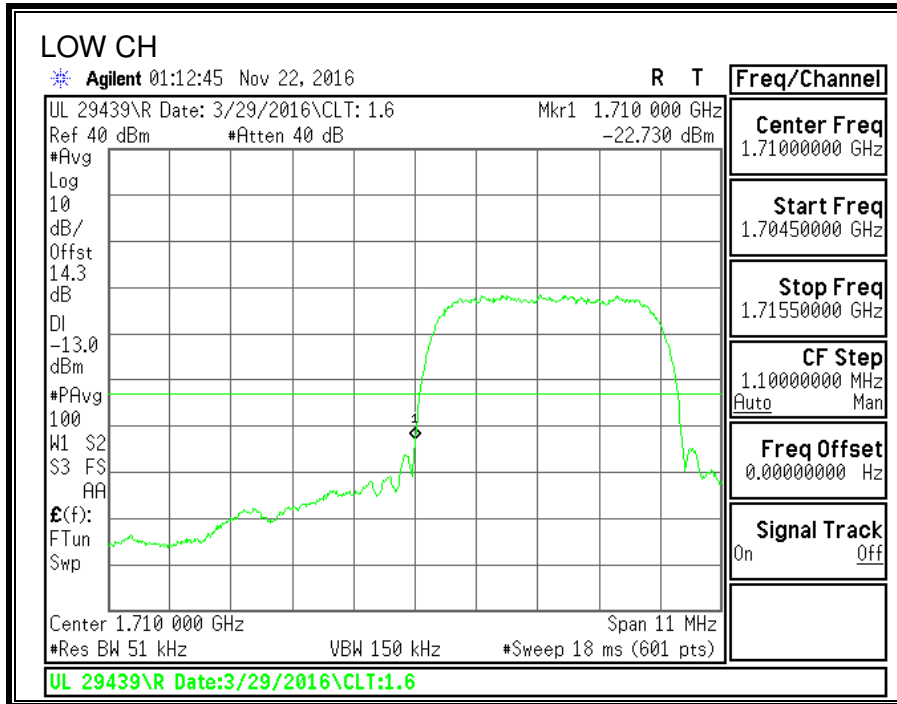

### 8.2.8. UMTS HSDPA

#### 850MHz BAND

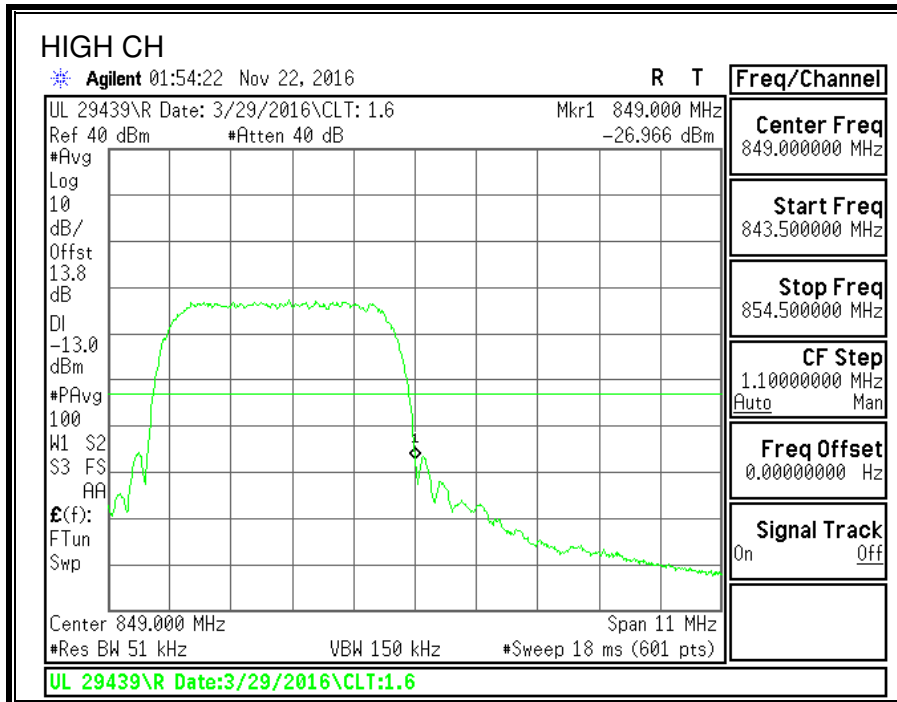
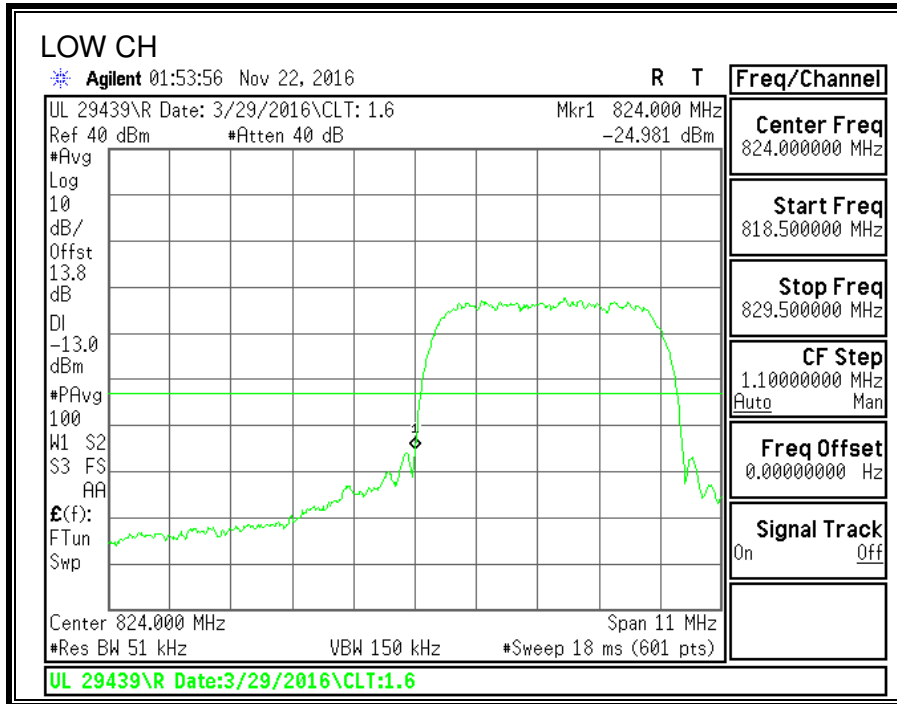

**1900MHz BAND**

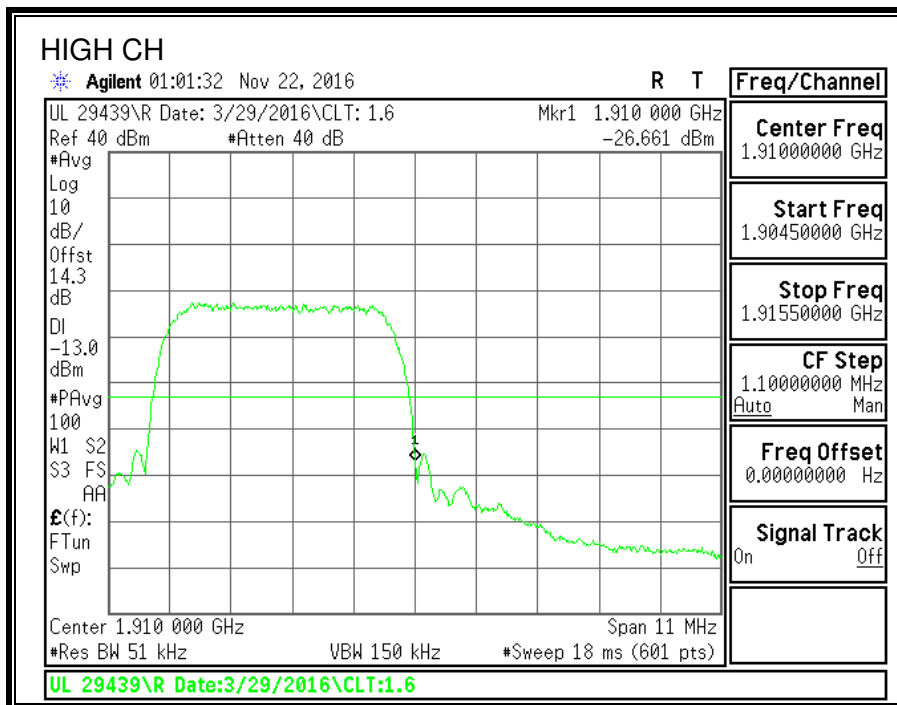
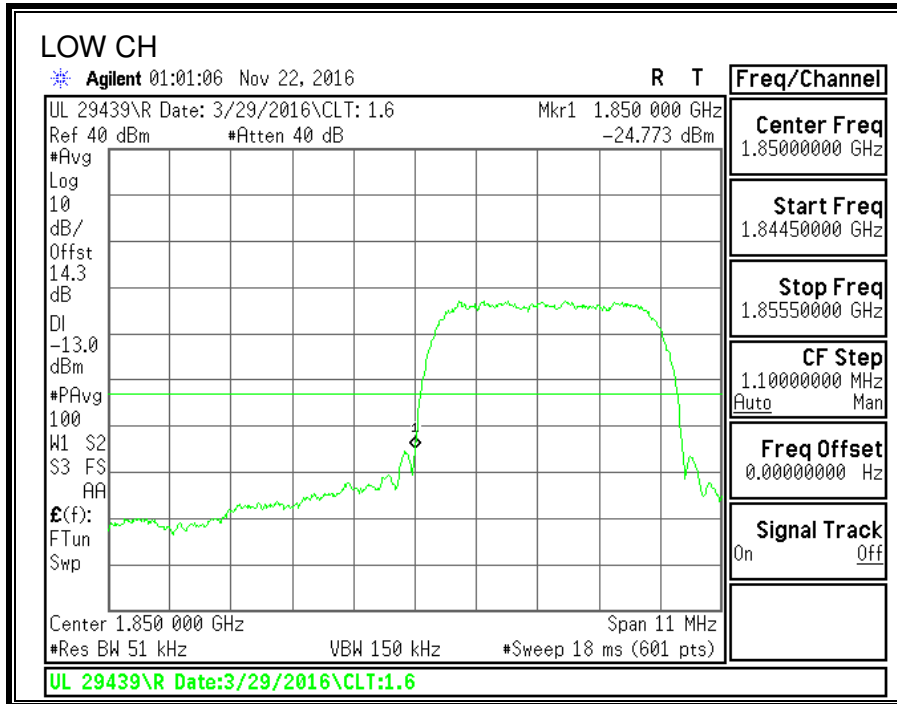

**1700MHz BAND**

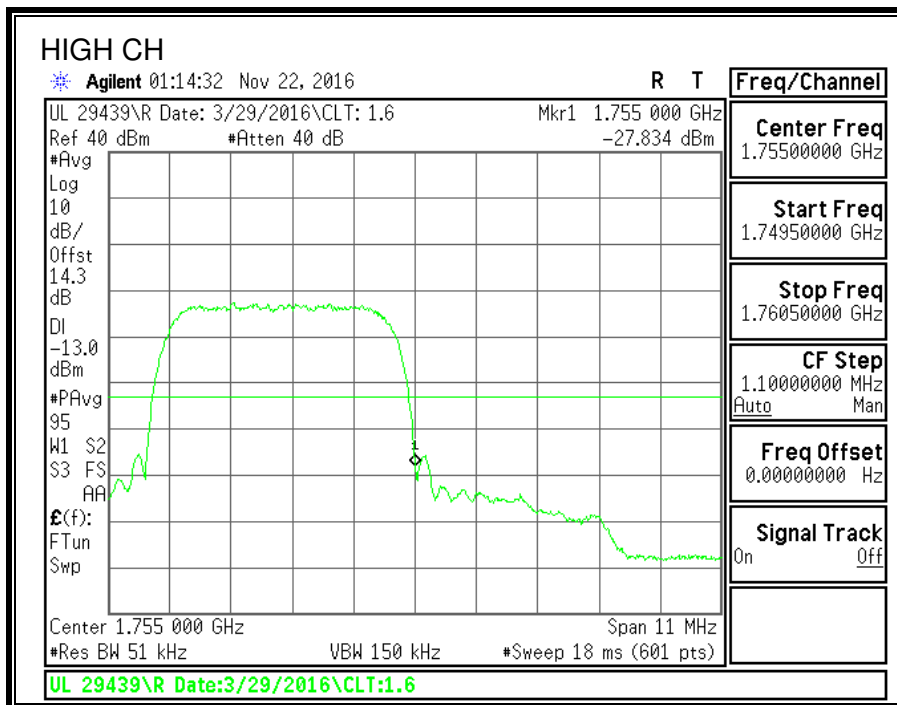
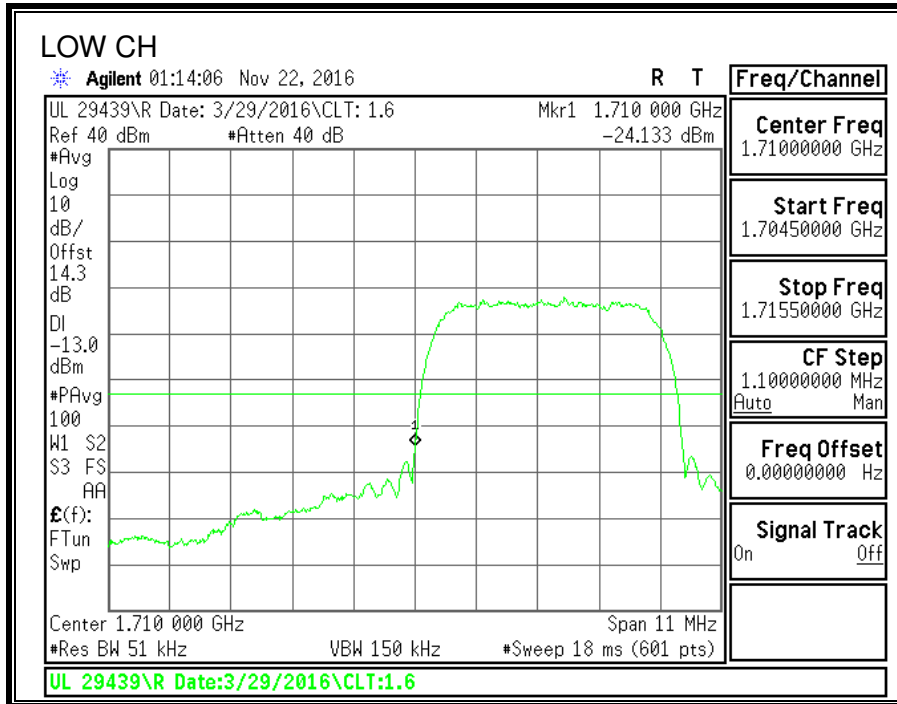

### 8.3. OUT OF BAND EMISSIONS

#### **RULE PART(S)**

FCC: §2.1051, §22.359, §22.917, §24.238 and §90.691  
IC: RSS132§5.5; RSS133§6.5 and RSS139§6.6

#### **LIMITS**

FCC: §22.359, §22.917, §24.238

The power of any emission outside of the authorized operating frequency ranges must be attenuated below the transmitting power (P) by a factor of at least  $43 + 10 \log (P)$  dB.

FCC: §27.53

- (c) On any frequency outside the 776–788 MHz band, the power of any emission shall be attenuated outside the band below the transmitter power (P) by at least  $43 + 10 \log (P)$  dB;
- (1) On any frequency outside the 746-758 MHz band, the power of any emission shall be attenuated outside the band below the transmitter power (P) by at least  $43 + 10 \log (P)$  dB;
- (2) On any frequency outside the 776-788 MHz band, the power of any emission shall be attenuated outside the band below the transmitter power (P) by at least  $43 + 10 \log (P)$  dB;
- (4) On all frequencies between 763-775 MHz and 793-805 MHz, by a factor not less than  $65 + 10 \log (P)$  dB in a 6.25 kHz band segment, for mobile and portable stations;
- (5) Compliance with the provisions of paragraphs (c)(1) and (c)(2) of this section is based on the use of measurement instrumentation employing a resolution bandwidth of 100 kHz or greater. However, in the 100 kHz bands immediately outside and adjacent to the frequency block, a resolution bandwidth of at least 30 kHz may be employed;
- (6) Compliance with the provisions of paragraphs (c)(3) and (c)(4) of this section is based on the use of measurement instrumentation such that the reading taken with any resolution bandwidth setting should be adjusted to indicate spectral energy in a 6.25 kHz segment.

FCC §90.691 Emission mask requirements for EA-based systems.

(a) Out-of-band emission requirement shall apply only to the “outer” channels included in an EA license and to spectrum adjacent to interior channels used by incumbent licensees. The emission limits are as follows:

- (1) For any frequency removed from the EA licensee's frequency block by up to and including 37.5 kHz, the power of any emission shall be attenuated below the transmitter power (P) in watts by at least  $116 \log_{10}(f/6.1)$  decibels or  $50 + 10 \log_{10}(P)$  decibels or 80 decibels, whichever is the lesser attenuation, where f is the frequency removed from the center of the outer channel in the block in kilohertz and where f is greater than 12.5 kHz.
- (2) For any frequency removed from the EA licensee's frequency block greater than 37.5 kHz, the power of any emission shall be attenuated below the transmitter power (P) in watts by at least  $43 + 10 \log_{10}(P)$  decibels or 80 decibels, whichever is the lesser attenuation, where f is the frequency removed from the center of the outer channel in the block in kilohertz and where f is greater than 37.5 kHz.

(b) When an emission outside of the authorized bandwidth causes harmful interference, the Commission may, at its discretion, require greater attenuation than specified in this section.

### RSS132§5.5

Mobile and base station equipment shall comply with the limits in (i) and (ii) below. In the first 1.0 MHz band immediately outside and adjacent to each of the sub-bands specified in Section 5.1, the power of emissions per any 1% of the occupied bandwidth shall be attenuated (in dB) below the transmitter output power  $P$  ( dBW) by at least  $43 + 10 \log_{10} p$  (watts).

After the first 1.0 MHz immediately outside and adjacent to each of the sub-bands, the power of emissions in any 100 kHz bandwidth shall be attenuated (in dB) below the transmitter output power  $P$  (dBW) by at least  $43 + 10 \log_{10} p$  (watts). If the measurement is performed using 1% of the occupied bandwidth, power integration over 100 kHz is required.

### RSS133§6.5

Equipment shall comply with the limits in (i) and (ii) below.

(i) In the 1.0 MHz bands immediately outside and adjacent to the equipment's operating frequency block, the emission power per any 1% of the emission bandwidth shall be attenuated (in dB) below the transmitter output power  $P$  (dBW) by at least  $43 + 10 \log_{10} p$  (watts).

(ii) After the first 1.0 MHz, the emission power in any 1 MHz bandwidth shall be attenuated (in dB) below the transmitter output power  $P$  (dBW) by at least  $43 + 10 \log_{10} p$  (watts). If the measurement is performed using 1% of the emission bandwidth, power integration over 1.0 MHz is required.

### RSS139§6.6

(i) In the first 1.0 MHz bands immediately outside and adjacent to the equipment's smallest operating frequency block, Footnote 2 which can contain the equipment's occupied bandwidth, the emission power per any 1% of the emission bandwidth shall be attenuated below the transmitter output power  $P$  (in dBW) by at least  $43 + 10 \log_{10} p$  (watts) dB.

(ii) After the first 1.0 MHz outside the equipment's smallest operating frequency block, which can contain the equipment's occupied bandwidth, the emission power in any 1 MHz bandwidth shall be attenuated below the transmitter output power  $P$  (in dBW) by at least  $43 + 10 \log_{10} p$  (watts) dB.

## **TEST PROCEDURE**

The RF output of the transmitter was connected to a spectrum analyzer through a calibrated coaxial cable. Sufficient scans were taken to show the out-of-band Emissions, if any, up to 10th harmonic. Multiple sweeps were recorded in maximum hold mode using a peak detector to ensure that the worst-case emissions were caught.

For each out of band emissions measurement:

- Set display line at -13 dBm
- Set RBW & VBW to 100 kHz for the measurement below 1 GHz, and 1 MHz for the measurement above 1 GHz.

## **RESULTS**

### 8.3.1. GSM GPRS

#### 850MHz BAND

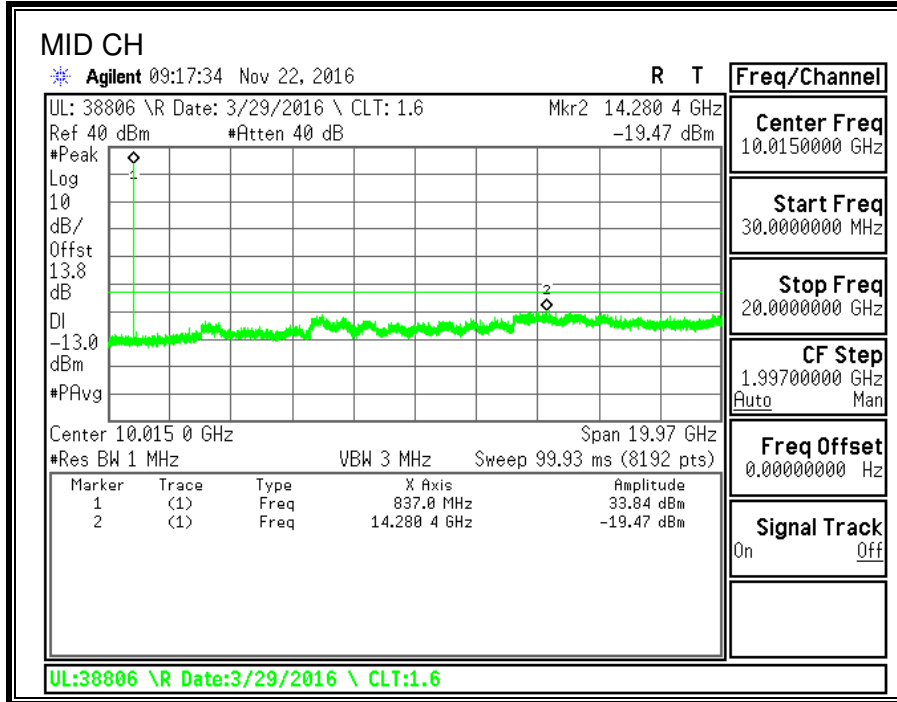

#### 1900MHz BAND

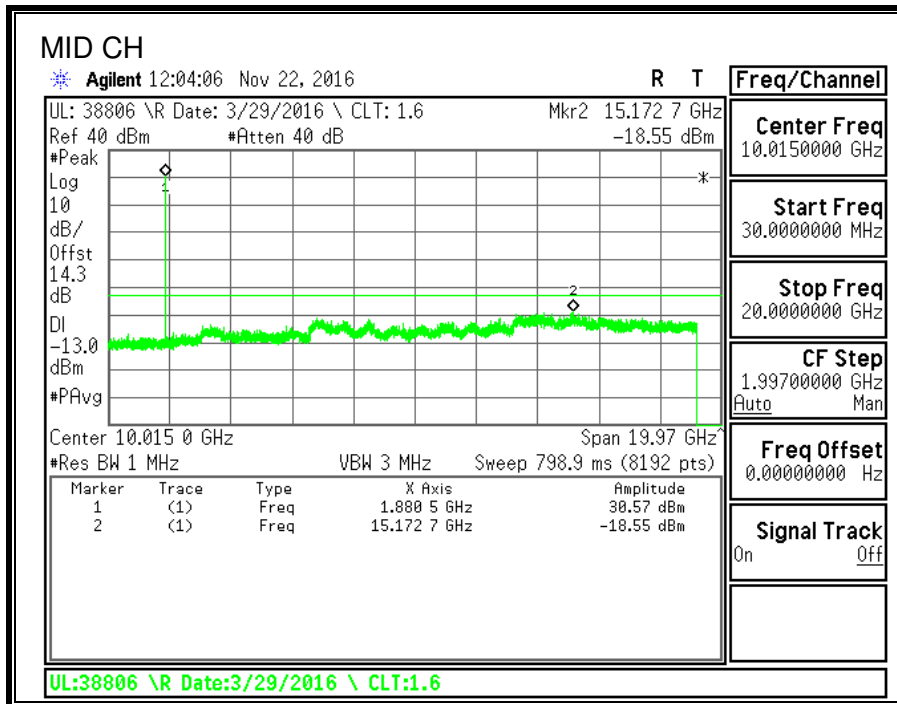

### 8.3.2. GSM EGPRS

#### 850MHz BAND

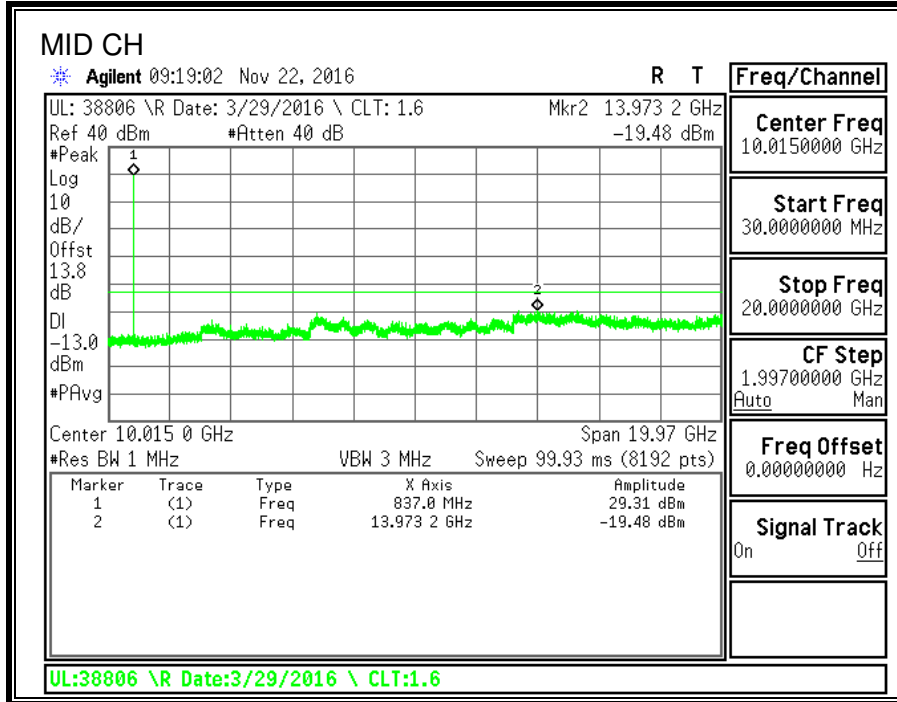

#### 1900MHz BAND

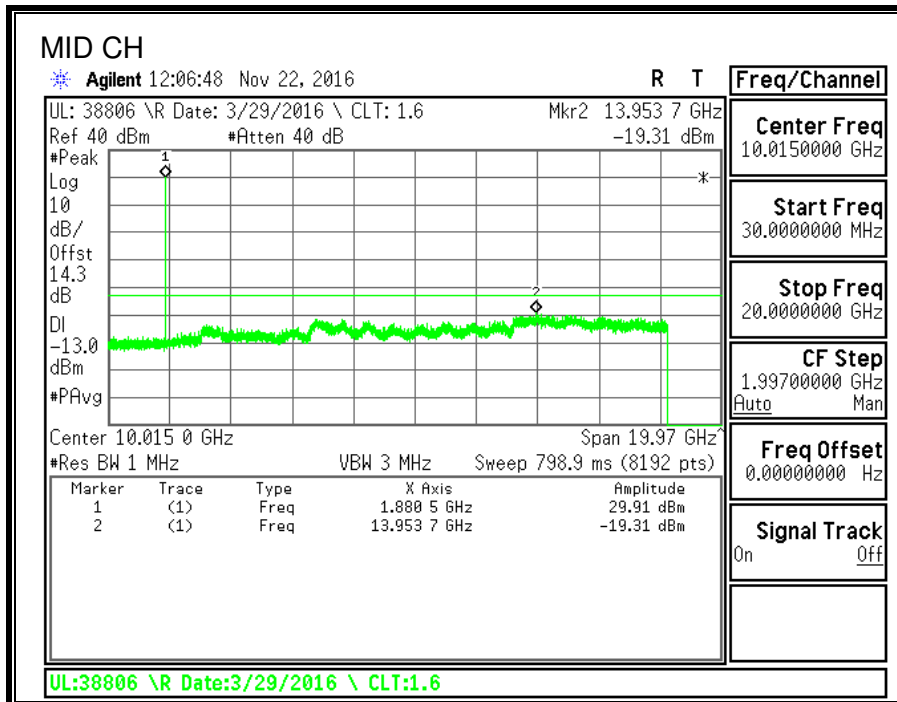

### 8.3.3. CDMA2000 1xRTT

#### 850MHz BAND

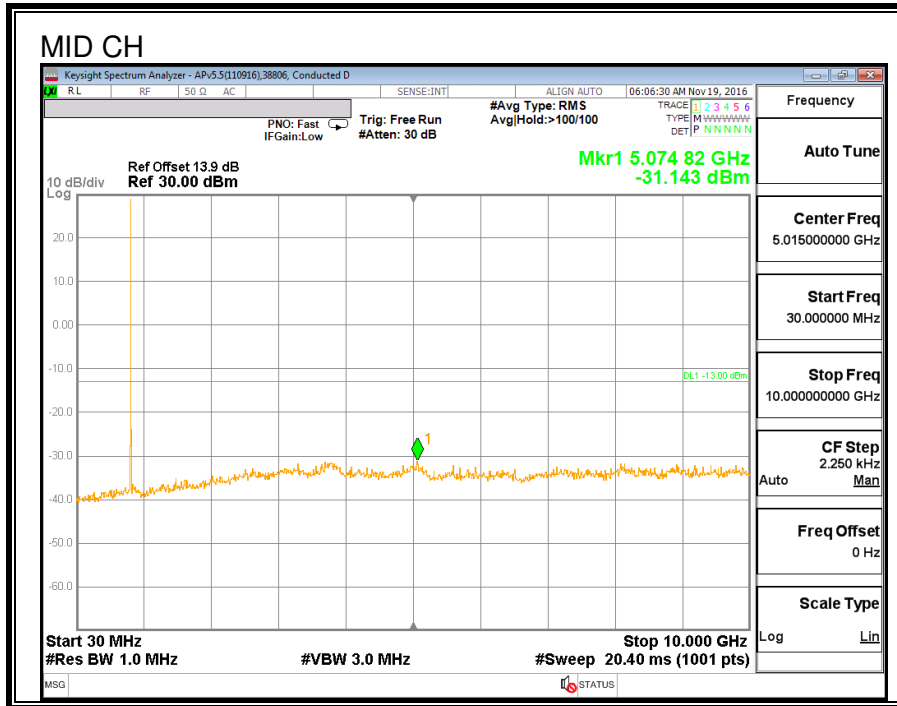

#### 1900MHz BAND

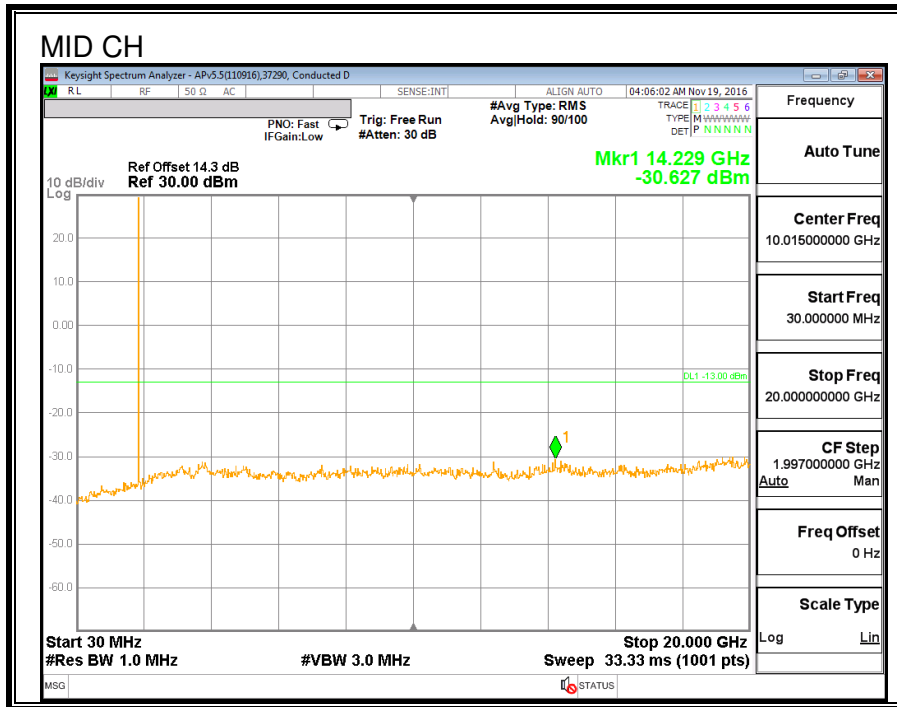

**800MHz SECONDARY BAND**

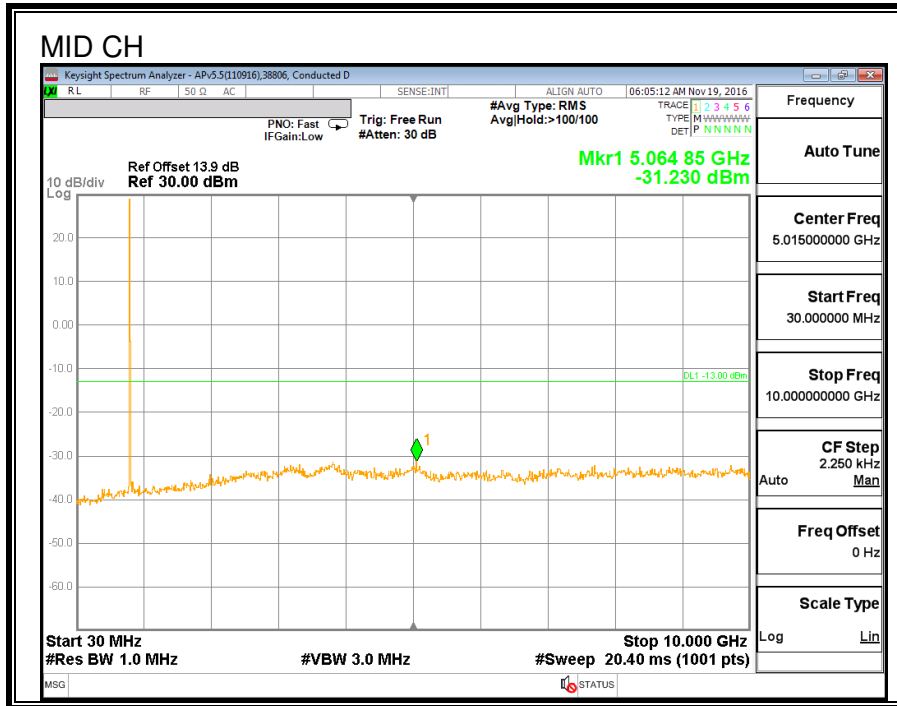

**8.3.4. CDMA2000 EVDO REV A**

**850MHz BAND**

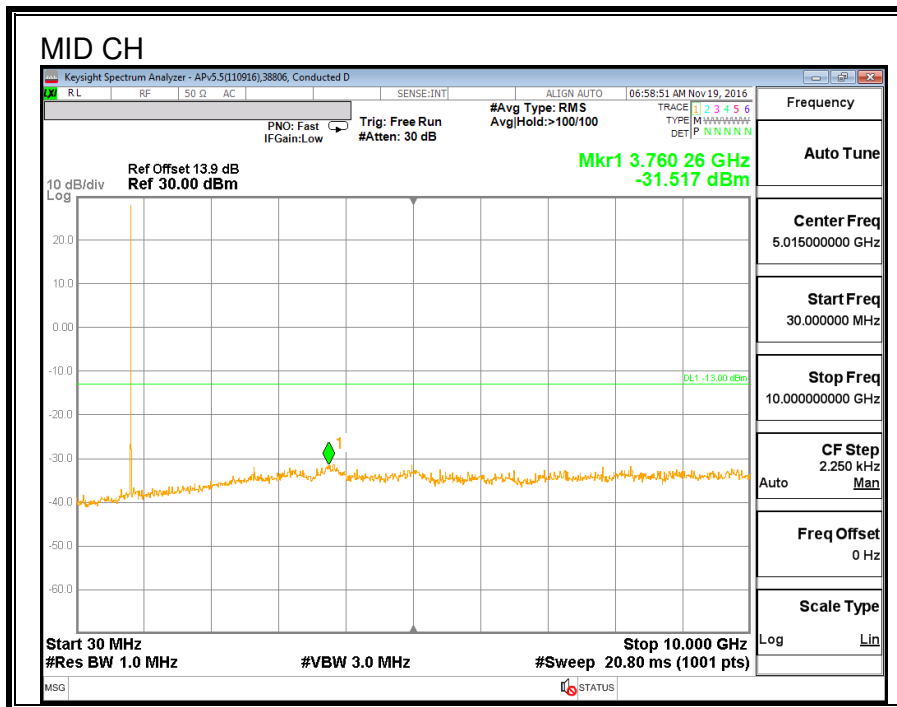

**1900MHz BAND**

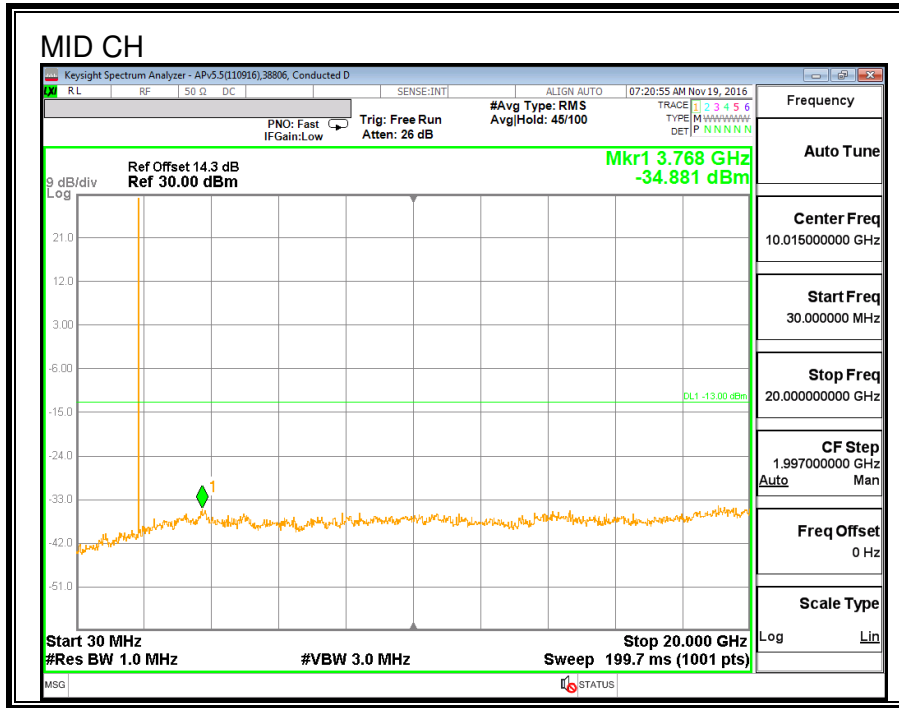

**800MHz SECONDARY BAND**

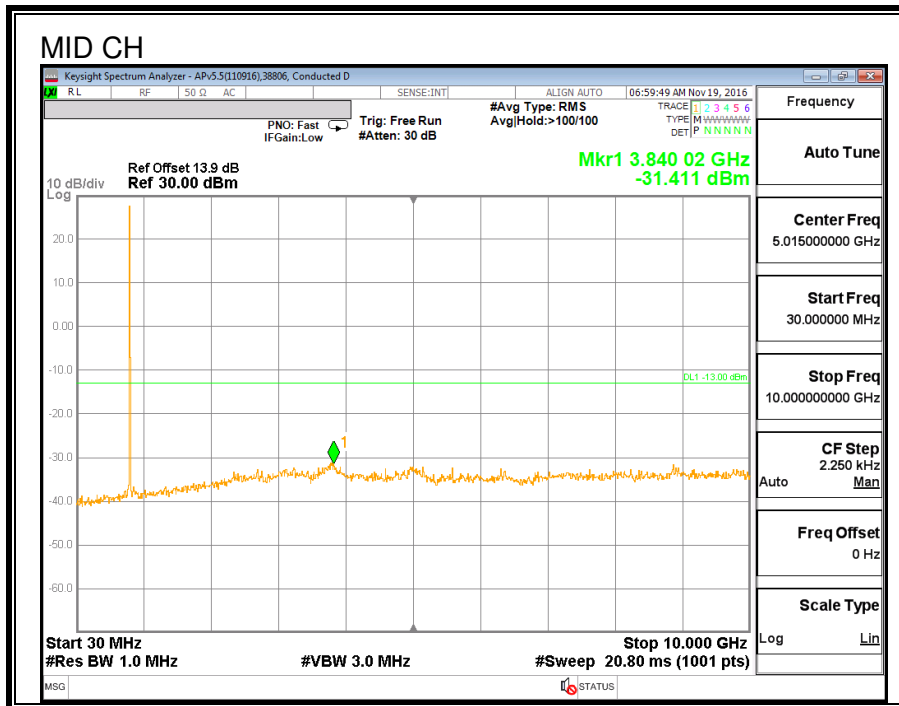

### 8.3.5. UMTS Rel99

#### 850MHz BAND

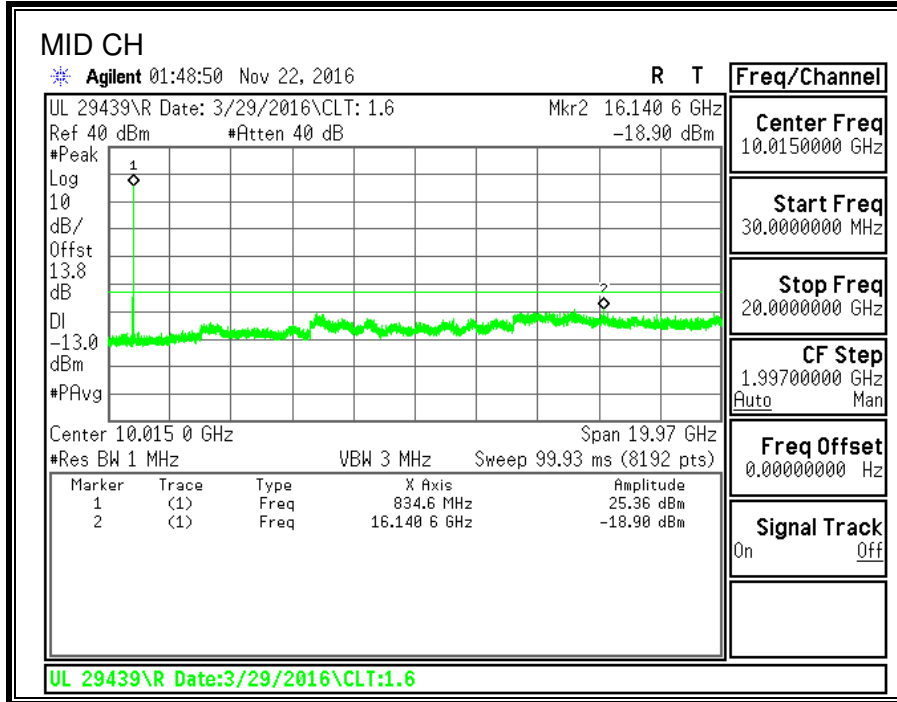

#### 1900MHz BAND

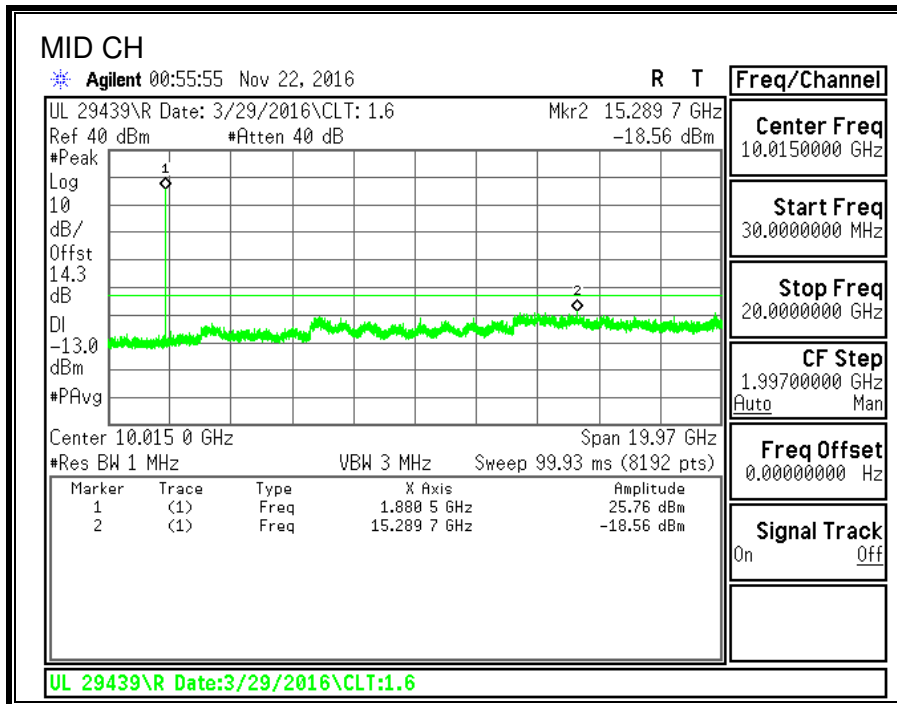

**1700MHz BAND**

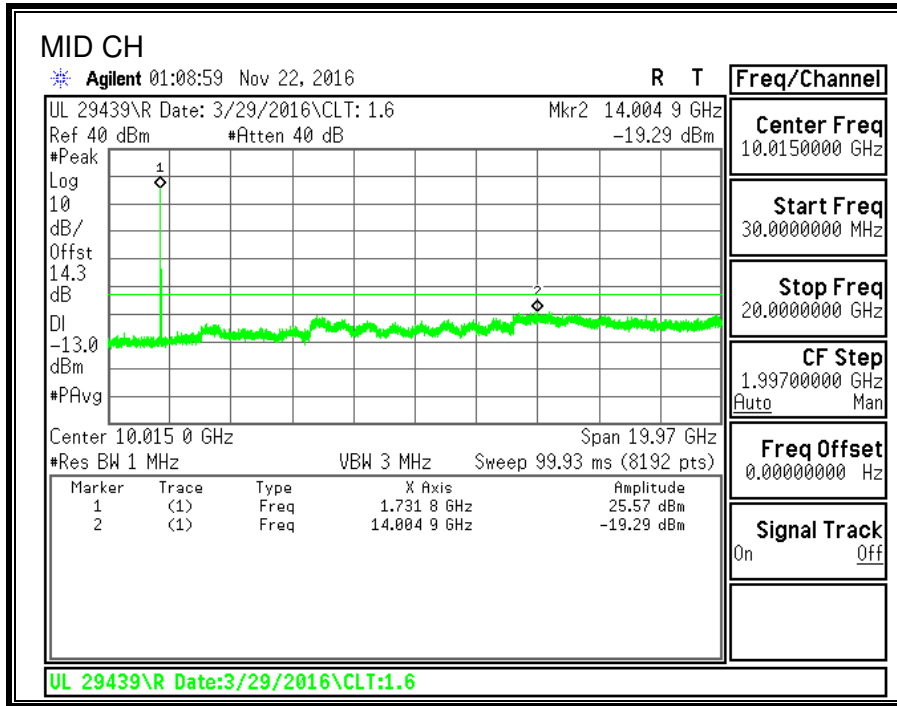

**8.3.6. UMTS HSDPA**

**850MHz BAND**

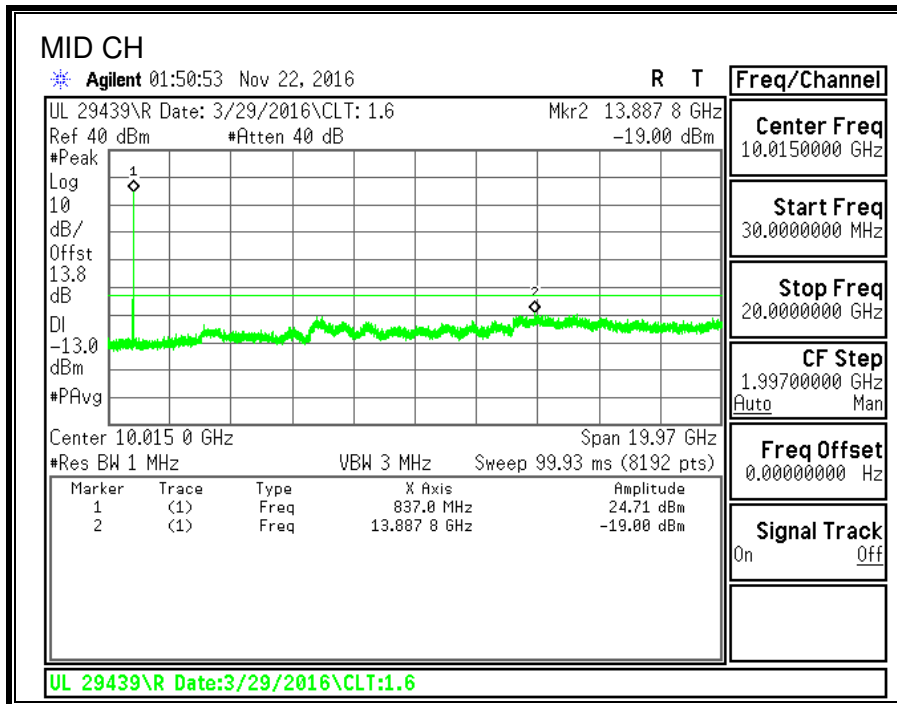

**1900MHz BAND**

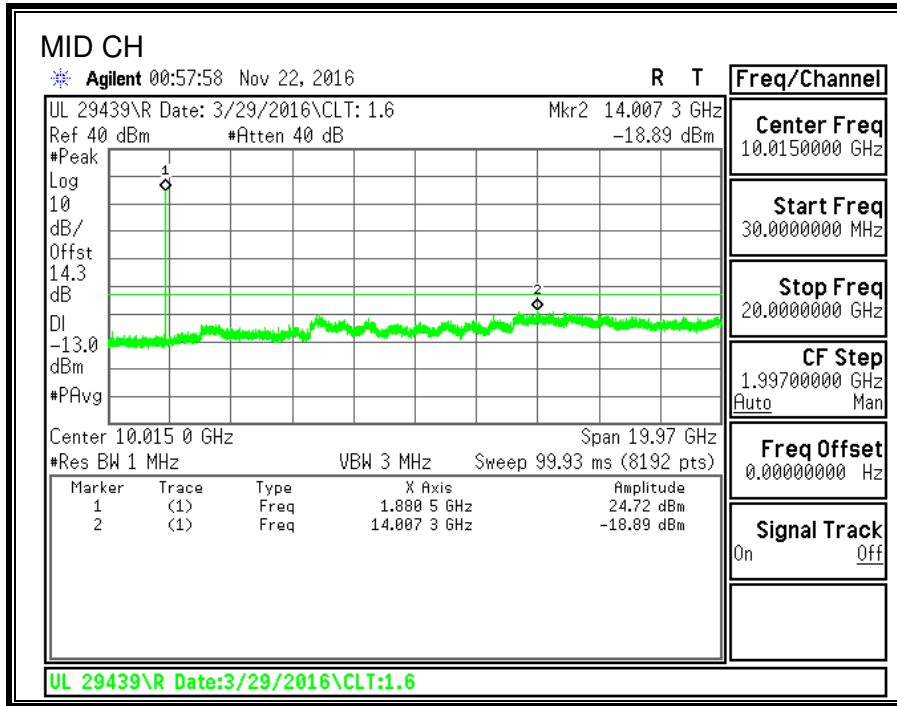

**1700MHz BAND**

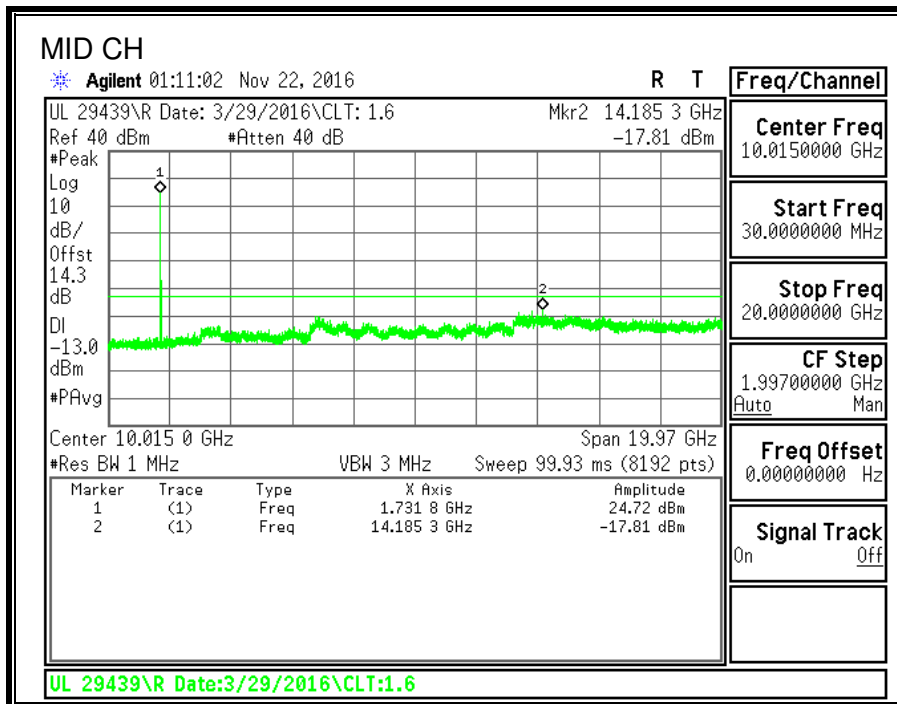

## 9. FREQUENCY STABILITY

### RULE PART(S)

FCC: §2.1055, §22.355, §24.235, §27.54 and §90.213  
IC: RSS132§5.3; RSS133§6.3 and RSS139§6.4

### LIMITS

FCC §22.355

The carrier frequency shall not depart from the reference frequency in excess of  $\pm 2.5$  ppm for mobile stations.

FCC §24.235 & §27.54

The frequency stability shall be sufficient to ensure that the fundamental emission stays within the authorized frequency block.

FCC §90.213

The carrier frequency shall not depart from the reference frequency in excess of  $\pm 2.5$  ppm for mobile stations

RSS132§5.3

The carrier frequency shall not depart from the reference frequency in excess of  $\pm 2.5$  SRSP for mobile stations and  $\pm 1.5$  ppm for base stations.

In lieu of meeting the above stability values, the test report may show that the frequency stability is sufficient to ensure that the occupied bandwidth stays within each of the sub-bands (see Section 5.1) when tested to the temperature and supply voltage variations specified in RSS-Gen.

RSS133§6.3

The carrier frequency shall not depart from the reference frequency, in excess of  $\pm 2.5$  ppm for mobile stations and  $\pm 1.0$  ppm for base stations.

In lieu of meeting the above stability values, the test report may show that the frequency stability is sufficient to ensure that the emission bandwidth stays within the operating frequency block when tested to the temperature and supply voltage variations specified in RSS-Gen.

RSS139§6.4

The frequency stability shall be sufficient to ensure that the occupied bandwidth stays within the operating frequency block when tested to the temperature and supply voltage variations specified in RSS-Gen.

### **TEST PROCEDURE**

Use CMW 500 with Frequency Error measurement capability.

- Temp. = -30° to +50°C
- Voltage = (85% - 115%)

Low voltage: 3.23VDC, Normal, 3.8VDC and High voltage, 4.37VDC.

End Voltage: 3.20VDC.

### **Frequency Stability vs Temperature:**

The EUT is placed inside a temperature chamber. The temperature is set to 20°C and allowed to stabilize. After sufficient soak time, the transmitting frequency error is measured. The temperature is increased by 10 degrees, allowed to stabilize and soak, and then the measurement is repeated. This is repeated until +50°C is reached.

### **Frequency Stability vs Voltage:**

The peak frequency error is recorded (worst-case).

### **RESULTS**

See the following pages.

### 9.1. GSM

<b>ID:</b>	39004	<b>Date:</b>	11/21/16
------------	-------	--------------	----------

#### GPRS 850

Limit		824	849	Delta (Hz)	Frequency Stability (ppm)
Condition		F low @ -13dBm (MHz)	F high @ -13dBm (MHz)		
Temperature	Voltage				
Normal (20C)	Normal	824.0209	848.9853		
Extreme (50C)		824.0208	848.9853	-11.5	-0.01
Extreme (40C)		824.0208	848.9853	-9.8	-0.01
Extreme (30C)		824.0208	848.9853	-8.6	-0.01
Extreme (10C)		824.0209	848.9853	7.6	0.01
Extreme (0C)		824.0209	848.9853	12.6	0.02
Extreme (-10C)		824.0209	848.9854	26.9	0.03
Extreme (-20C)		824.0209	848.9854	26.2	0.03
Extreme (-30C)		824.0209	848.9853	23.6	0.03
20C	15%	824.0208	848.9853	-7.5	-0.01
	-15%	824.0209	848.9853	6.8	0.01
	End Point	824.0208	848.9853	-12.3	-0.01

#### EGPRS 850

Limit		824	849	Delta (Hz)	Frequency Stability (ppm)
Condition		F low @ -13dBm (MHz)	F high @ -13dBm (MHz)		
Temperature	Voltage				
Normal (20C)	Normal	824.0437	848.9640		
Extreme (50C)		824.0437	848.9640	10.2	0.01
Extreme (40C)		824.0438	848.9640	16.9	0.02
Extreme (30C)		824.0438	848.9640	25.4	0.03
Extreme (10C)		824.0438	848.9641	42.2	0.05
Extreme (0C)		824.0438	848.9641	40.7	0.05
Extreme (-10C)		824.0438	848.9640	24.9	0.03
Extreme (-20C)		824.0438	848.9640	35.8	0.04
Extreme (-30C)		824.0438	848.9640	29.7	0.04
20C	15%	824.0438	848.9640	24.5	0.03
	-15%	824.0438	848.9640	22.2	0.03
	End Point	824.0437	848.9640	-11.0	-0.01

**GPRS 1900**

Limit		1850	1910	Delta (Hz)	Frequency Stability (ppm)
Condition		F low @ -13dBm (MHz)	F high @ -13dBm (MHz)		
Temperature	Voltage				
Normal (20C)	Normal	1850.030381	1909.970405		
Extreme (50C)		1850.030339	1909.970362	-42.51	-0.02
Extreme (40C)		1850.030350	1909.970373	-31.57	-0.02
Extreme (30C)		1850.030328	1909.970351	-53.62	-0.03
Extreme (10C)		1850.030320	1909.970344	-61.32	-0.03
Extreme (0C)		1850.030317	1909.970341	-64.35	-0.03
Extreme (-10C)		1850.030422	1909.970446	40.53	0.02
Extreme (-20C)		1850.030340	1909.970364	-41.35	-0.02
Extreme (-30C)		1850.030342	1909.970365	-39.78	-0.02
20C	15%	1850.030350	1909.970374	-31.25	-0.02
	-15%	1850.030352	1909.970375	-29.63	-0.02
	End Point	1850.0304	1909.970382	-23.34	-0.01

**EGPRS 1900**

Limit		1850	1910	Delta (Hz)	Frequency Stability (ppm)
Condition		F low @ -13dBm (MHz)	F high @ -13dBm (MHz)		
Temperature	Voltage				
Normal (20C)	Normal	1850.042438	1909.961351		
Extreme (50C)		1850.042391	1909.961304	-47.62	-0.03
Extreme (40C)		1850.042471	1909.961384	32.81	0.02
Extreme (30C)		1850.042374	1909.961287	-64.52	-0.03
Extreme (10C)		1850.042504	1909.961417	65.30	0.03
Extreme (0C)		1850.042493	1909.961406	54.72	0.03
Extreme (-10C)		1850.042407	1909.961319	-31.84	-0.02
Extreme (-20C)		1850.042492	1909.961405	53.43	0.03
Extreme (-30C)		1850.042491	1909.961404	52.72	0.03
20C	15%	1850.042470	1909.961383	32.11	0.02
	-15%	1850.042419	1909.961332	-19.23	-0.01
	End Point	1850.0424	1909.961330	-21.46	-0.01

## 9.2. CDMA2000

### CDMA 1xRTT BC0

Limit		824	849	Delta (Hz)	Frequency Stability (ppm)
Condition		F low @ -13dBm (MHz)	F high @ -13dBm (MHz)		
Temperature	Voltage				
Normal (20C)	Normal	824.020661	848.997508		
Extreme (50C)		824.020657	848.997503	-4.61	-0.01
Extreme (40C)		824.020657	848.997504	-3.88	0.00
Extreme (30C)		824.020663	848.997510	1.76	0.00
Extreme (10C)		824.020666	848.997512	4.25	0.01
Extreme (0C)		824.020667	848.997513	5.42	0.01
Extreme (-10C)		824.020667	848.997514	5.71	0.01
Extreme (-20C)		824.020666	848.997513	5.20	0.01
Extreme (-30C)		824.020666	848.997513	4.97	0.01
20C	15%	824.020658	848.997504	-3.44	0.00
	-15%	824.020657	848.997504	-4.25	-0.01
	End Point	824.020656	848.99750273	-5.12	-0.01

### CDMA 1x RTT BC1

Limit		1850	1910	Delta (Hz)	Frequency Stability (ppm)
Condition		F low @ -13dBm (MHz)	F high @ -13dBm (MHz)		
Temperature	Voltage				
Normal (20C)	Normal	1850.540000	1909.464000		
Extreme (50C)		1850.539992	1909.463992	-7.91	0.00
Extreme (40C)		1850.539995	1909.463995	-5.42	0.00
Extreme (30C)		1850.539996	1909.463996	-4.17	0.00
Extreme (10C)		1850.540001	1909.464001	0.59	0.00
Extreme (0C)		1850.540004	1909.464004	4.32	0.00
Extreme (-10C)		1850.540007	1909.464007	7.10	0.00
Extreme (-20C)		1850.540010	1909.464010	9.65	0.01
Extreme (-30C)		1850.540008	1909.464008	8.20	0.00
20C	15%	1850.539993	1909.463993	-7.03	0.00
	-15%	1850.539991	1909.463991	-9.30	0.00
	End Point	1850.539990	1909.463990	-10.10	-0.01

**CDMA 1xRTT BC10**

Limit		816.35	823.65	Delta (Hz)	Frequency Stability (ppm)
Condition		F low @ -13dBm (MHz)	F high @ -13dBm (MHz)		
Temperature	Voltage				
Normal (20C)	Normal	816.569255	823.433052		
Extreme (50C)		816.569249	823.433046	-5.57	-0.01
Extreme (40C)		816.569251	823.433048	-3.44	0.00
Extreme (30C)		816.569257	823.433054	2.42	0.00
Extreme (10C)		816.569258	823.433055	3.30	0.00
Extreme (0C)		816.569260	823.433057	5.13	0.01
Extreme (-10C)		816.569261	823.433058	6.08	0.01
Extreme (-20C)		816.569260	823.433056	4.83	0.01
Extreme (-30C)		816.569259	823.433055	3.81	0.00
20C	15%	816.569254	823.433050	-1.25	0.00
	-15%	816.569251	823.433048	-3.44	0.00
	End Point	816.5693	823.433047	-4.67	-0.01

### 9.3. UMTS

#### WCDMA REL99 BAND 5

Limit		824	849	Delta (Hz)	Frequency Stability (ppm)
Condition		F low @ -13dBm (MHz)	F high @ -13dBm (MHz)		
Temperature	Voltage				
Normal (20C)	Normal	824.14104	848.85301		
Extreme (50C)		824.14104	848.85301	3.69	0.00
Extreme (40C)		824.14103	848.85300	-4.63	-0.01
Extreme (30C)		824.14103	848.85300	-6.47	-0.01
Extreme (10C)		824.14104	848.85301	5.91	0.01
Extreme (0C)		824.14103	848.85300	-7.10	-0.01
Extreme (-10C)		824.14104	848.85301	6.62	0.01
Extreme (-20C)		824.14104	848.85301	3.27	0.00
Extreme (-30C)		824.14102	848.85299	-15.31	-0.02
20C	15%	824.14103	848.85301	-2.65	0.00
	-15%	824.14104	848.85301	3.29	0.00
	End Point	824.14104	848.85301	1.42	0.00

#### WCDMA REL99 BAND 2

Limit		1850	1910	Delta (Hz)	Frequency Stability (ppm)
Condition		F low @ -13dBm (MHz)	F high @ -13dBm (MHz)		
Temperature	Voltage				
Normal (20C)	Normal	1850.149050	1909.866408		
Extreme (50C)		1850.149080	1909.866438	30.18	0.02
Extreme (40C)		1850.149099	1909.866457	48.76	0.03
Extreme (30C)		1850.149088	1909.866446	37.97	0.02
Extreme (10C)		1850.149000	1909.866358	-50.18	-0.03
Extreme (0C)		1850.148994	1909.866352	-55.77	-0.03
Extreme (-10C)		1850.148990	1909.866348	-60.33	-0.03
Extreme (-20C)		1850.149113	1909.866471	63.07	0.03
Extreme (-30C)		1850.149023	1909.866381	-26.66	-0.01
20C	15%	1850.149044	1909.866402	-6.39	0.00
	-15%	1850.149040	1909.866398	-10.43	-0.01
	End Point	1850.149046	1909.866404	-4.02	0.00

**WCDMA REL99 BAND 4**

Limit		1710	1755	Delta (Hz)	Frequency Stability (ppm)
Condition		F low @ -13dBm (MHz)	F high @ -13dBm (MHz)		
Temperature	Voltage				
Normal (20C)	Normal	1710.13198	1754.85544		
Extreme (50C)		1710.13195	1754.85540	-31.31	-0.02
Extreme (40C)		1710.13196	1754.85542	-16.24	-0.01
Extreme (30C)		1710.13196	1754.85542	-17.07	-0.01
Extreme (10C)		1710.13199	1754.85545	13.30	0.01
Extreme (0C)		1710.13196	1754.85542	-17.64	-0.01
Extreme (-10C)		1710.13199	1754.85545	9.63	0.01
Extreme (-20C)		1710.13196	1754.85542	-16.57	-0.01
Extreme (-30C)		1710.13200	1754.85546	19.25	0.01
20C	15%	1710.13197	1754.85543	-7.40	0.00
	-15%	1710.13197	1754.85542	-11.74	-0.01
	End Point	1710.13198	1754.85543	-5.69	0.00

## 10. PEAK-TO-AVERAGE RATIO

In addition, when the transmitter power is measured in terms of average value, the peak-to-average ratio of the power shall not exceed 13 dB.

### RESULTS

Antenna C was used to measure as the worst case. The results from all CCDF plots are passed with 13dB peak-to-average ratio criteria.

<b>ID:</b>	50820	<b>Date:</b>	11/22/16
------------	-------	--------------	----------

Mode	Modulation	Conducted Power (dBm)		Peak-to-Average Ratio
		*Peak	Average	
GSM850	GPRS	33.66	33.46	0.20
	EGPRS	31.51	27.96	3.55
GSM1900	GPRS	29.75	29.35	0.40
	EGPRS	29.93	26.70	3.23

\*Peak Reading = Average Reading + Peak - to - Average Ratio

Mode	Modulation	Conducted Power (dBm)		Peak-to-Average Ratio
		*Peak	Average	
CDMA2000 BC0	1xRTT	28.96	24.48	4.48
	EVDO A	28.5	24.43	4.07
CDMA2000 BC1	1xRTT	30.03	25.96	4.07
	EVDO A	31.54	26.00	5.54
CDMA2000 BC10	1xRTT	30.53	25.99	4.54
	EVDO A	31.50	25.95	5.55

\*Peak Reading = Average Reading + Peak - to - Average Ratio

Mode	Modulation	Conducted Power (dBm)		Peak-to-Average Ratio
		*Peak	Average	
UMTS Band 5	REL99	28.67	25.43	3.24
	HSDPA	27.69	24.40	3.29
UMTS Band 2	REL99	28.3	25.34	2.96
	HSDPA	27.57	24.31	3.26
UMTS Band 4	REL99	28.63	25.41	3.22
	HSDPA	27.67	24.39	3.28

\*Peak Reading = Average Reading + Peak - to - Average Ratio

**GSM850, GPRS**

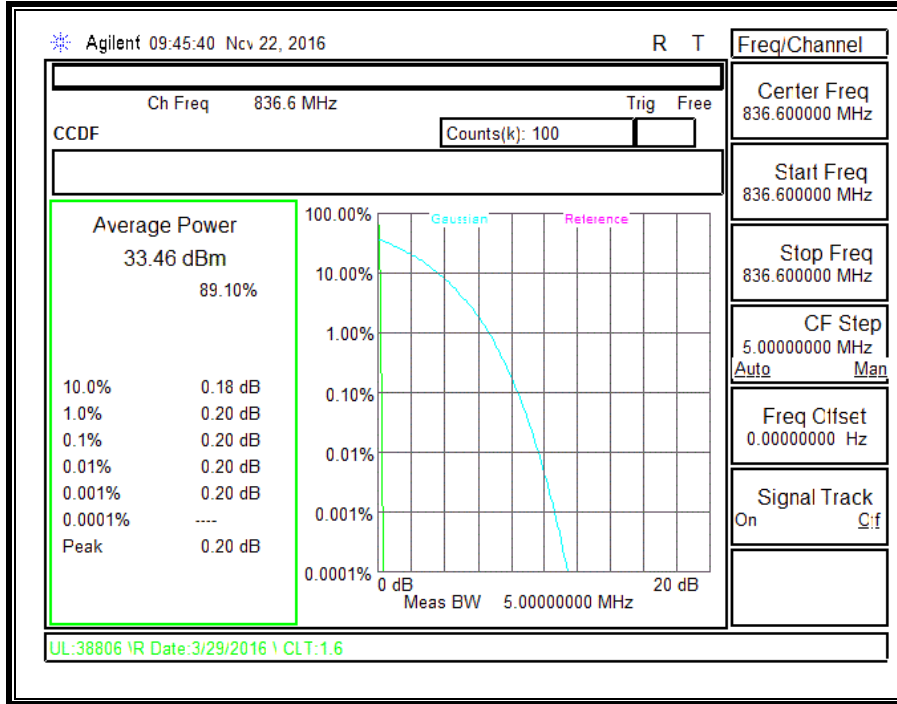

**GSM850, EGPRS**

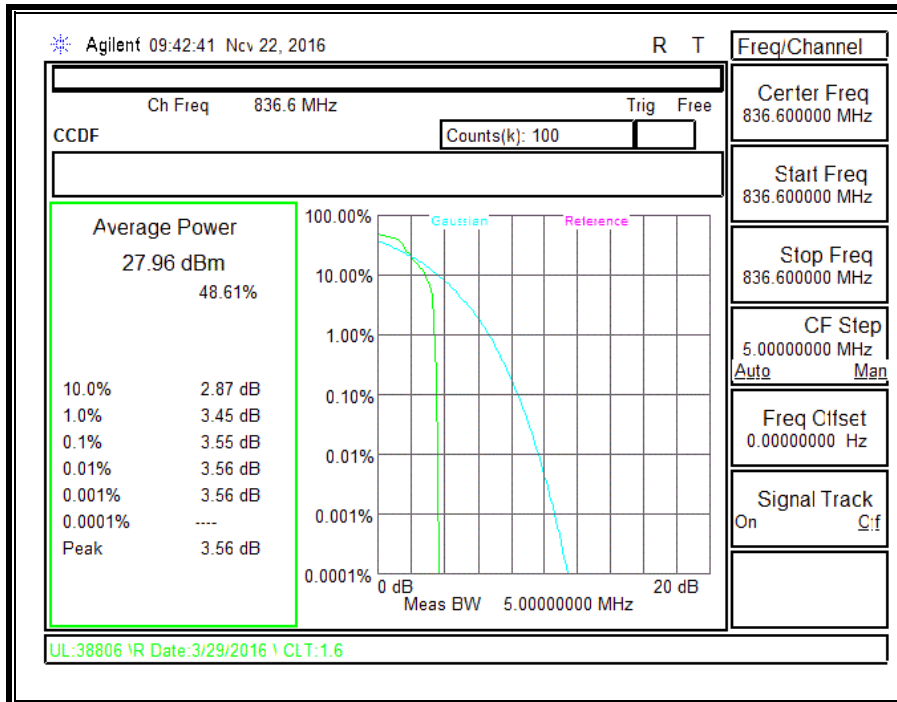

**GSM1900, GPRS**

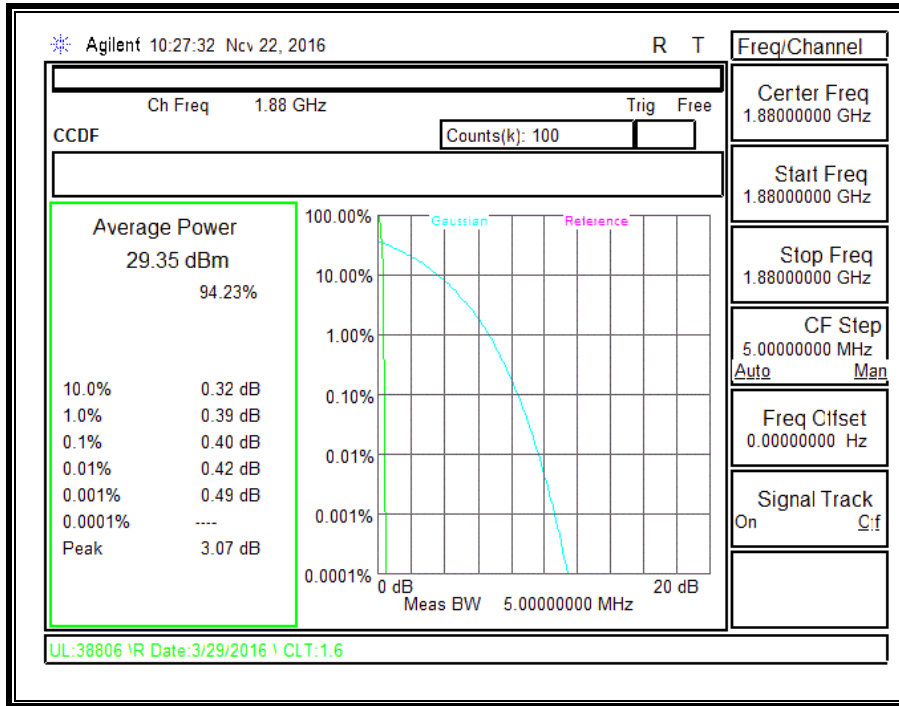

**GSM1900, EGPRS**

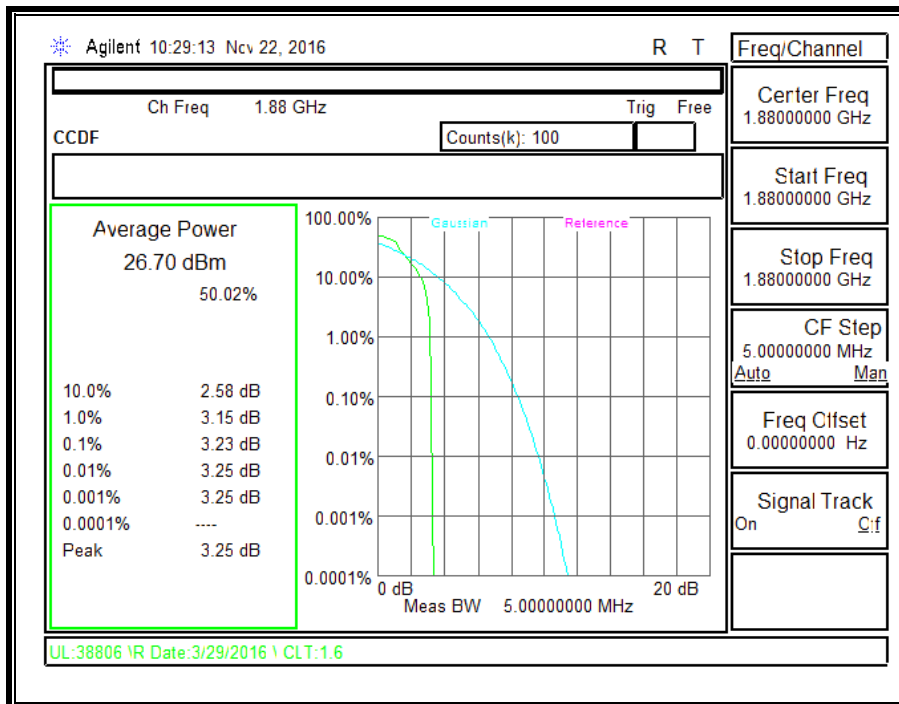

**BC 0, 1xRTT**

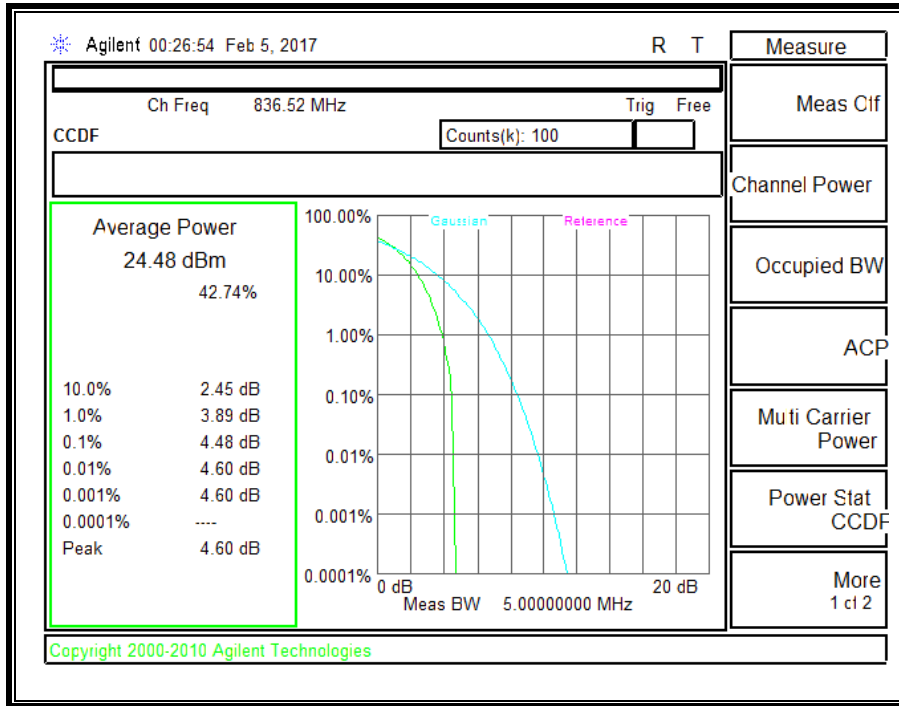

**BC 0, EVDO A**

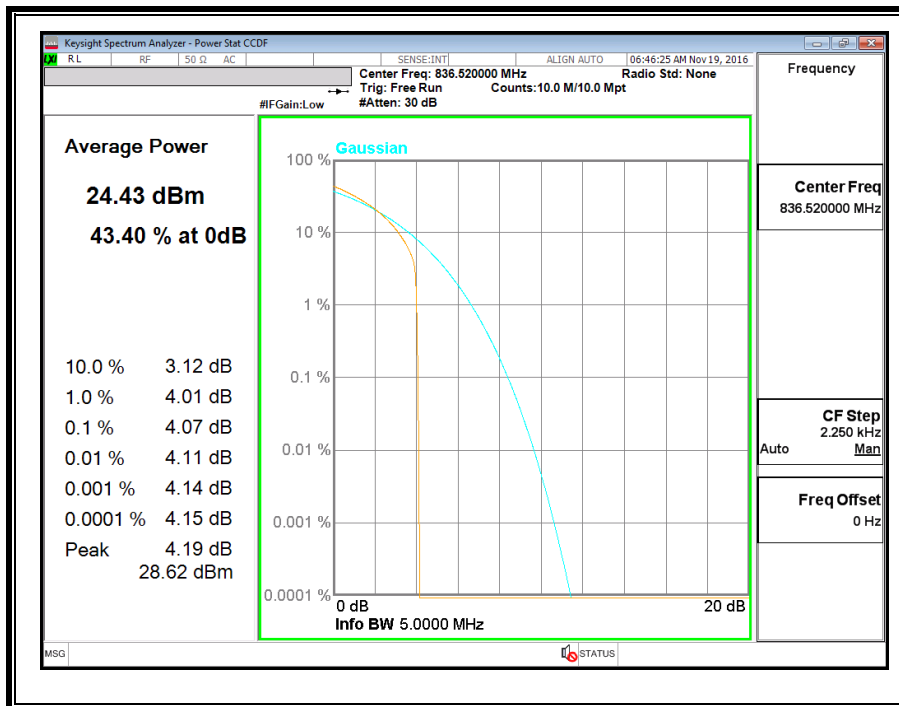

**BC 1, 1xRTT**

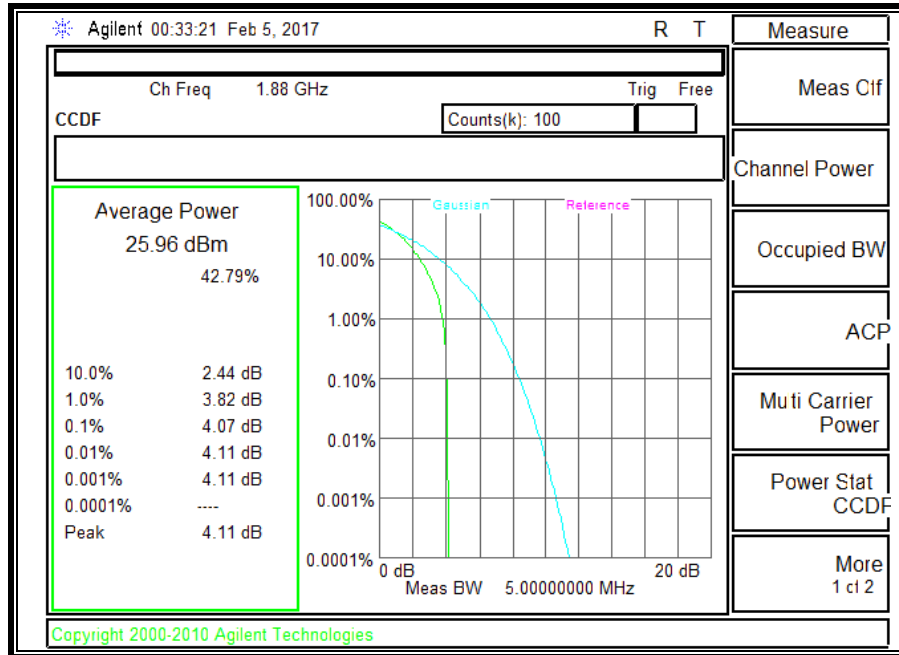

**BC 1, EVDO A**

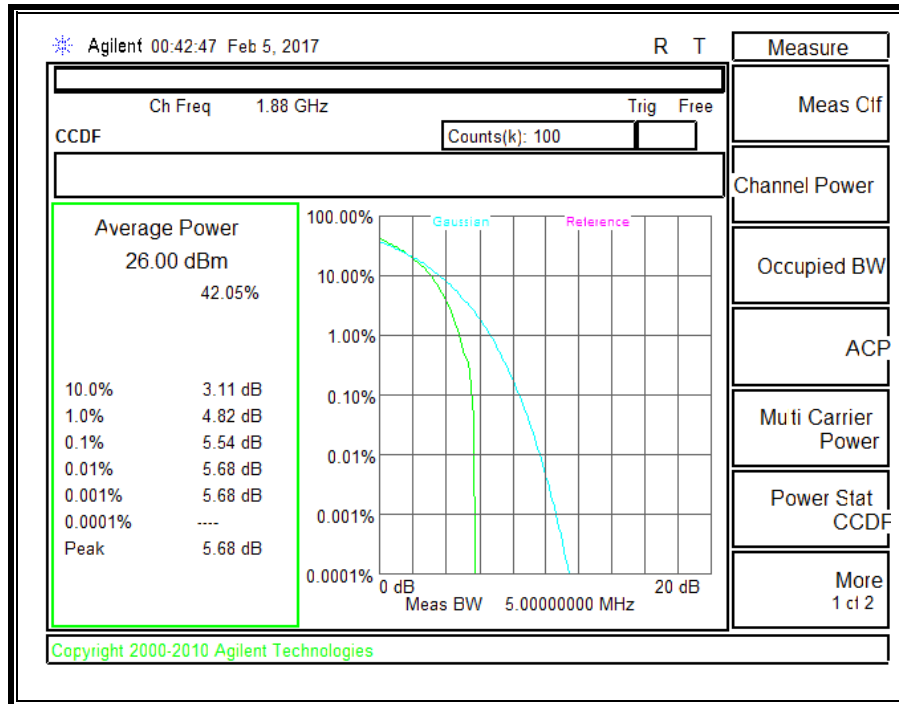

**BC10, 1xRTT**

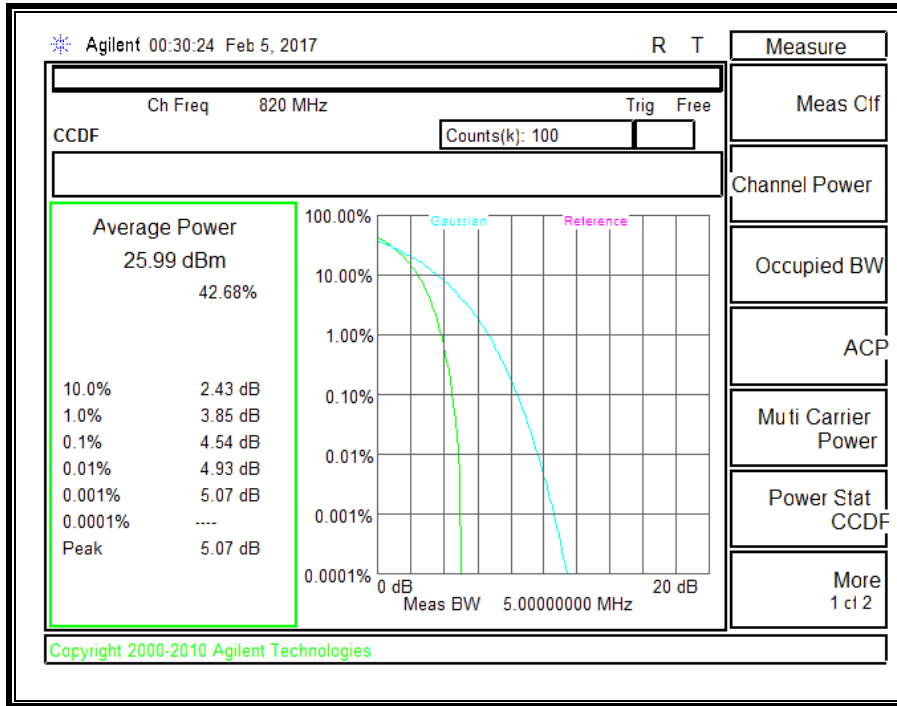

**BC10, EVDO A**

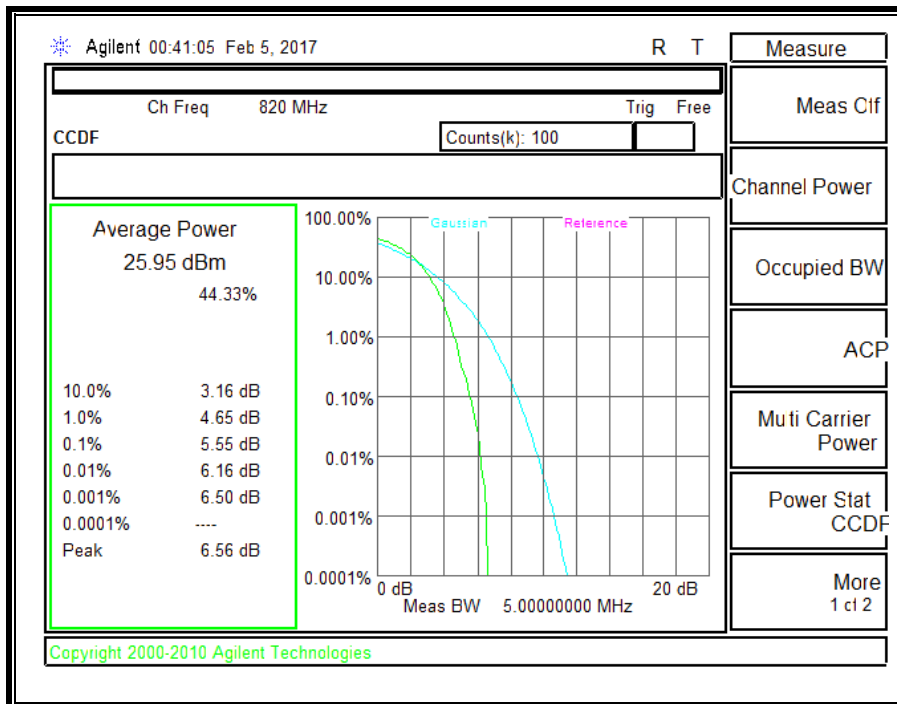

**UMTS 850, REL99 BAND 5**

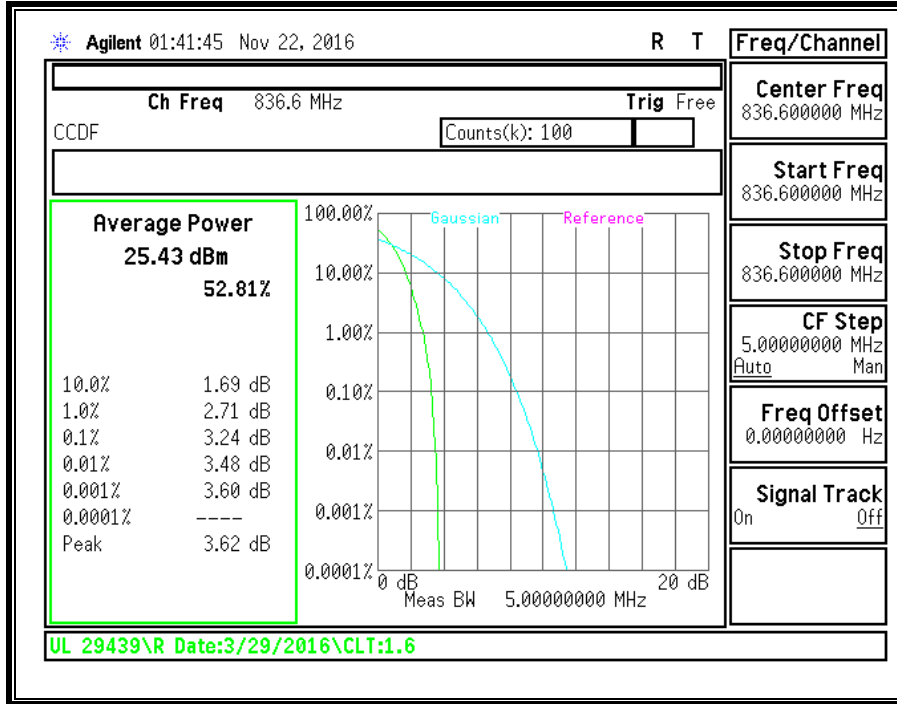

**UMTS 850, HSDPA BAND 5**

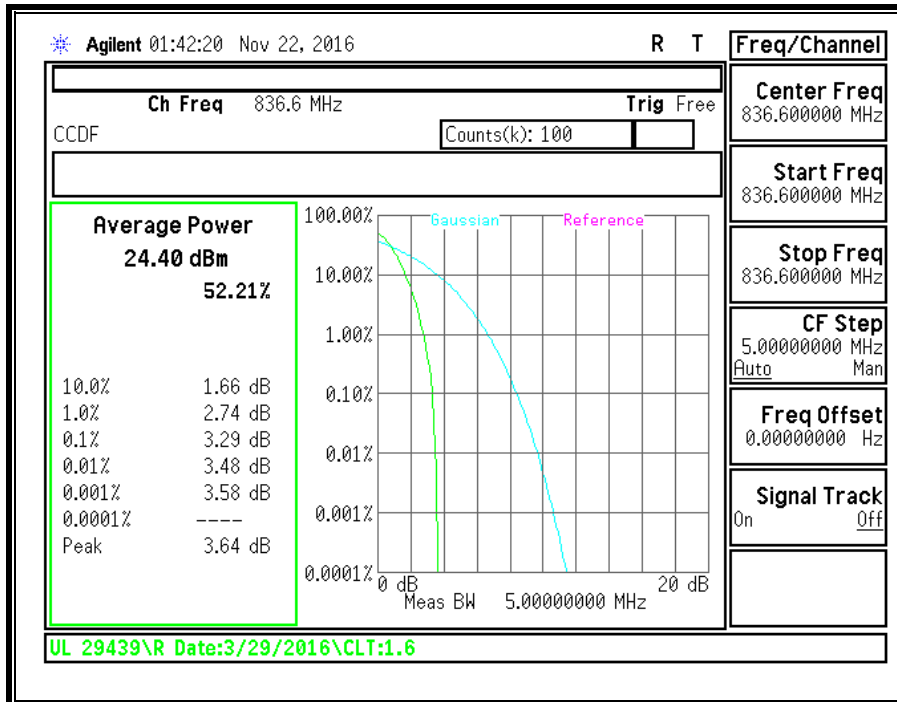

**UMTS 1900, REL99 BAND 2**

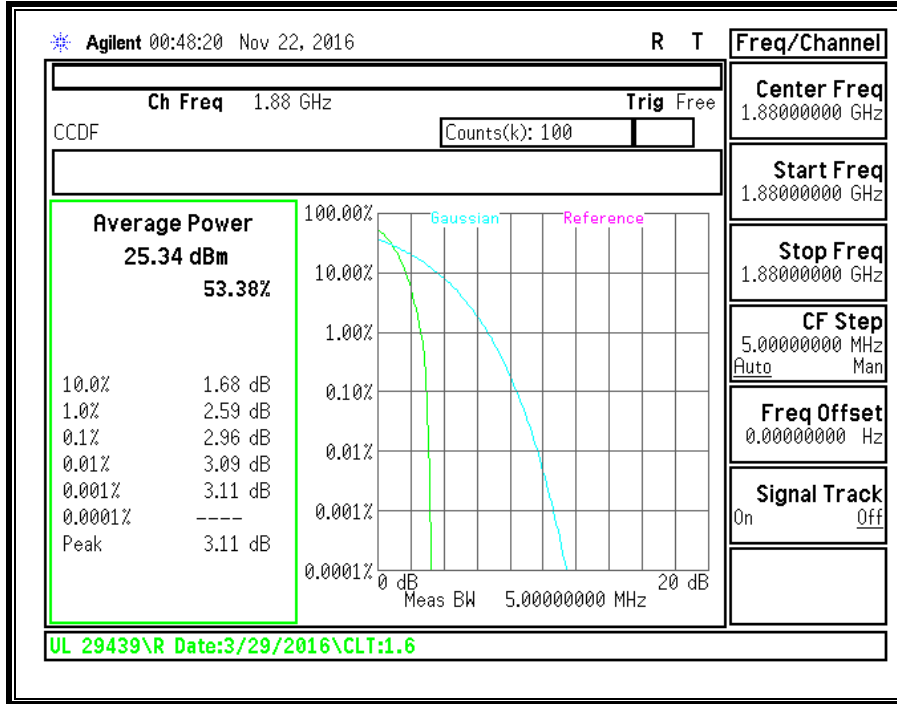

**UMTS 1900, HSDPA BAND 2**

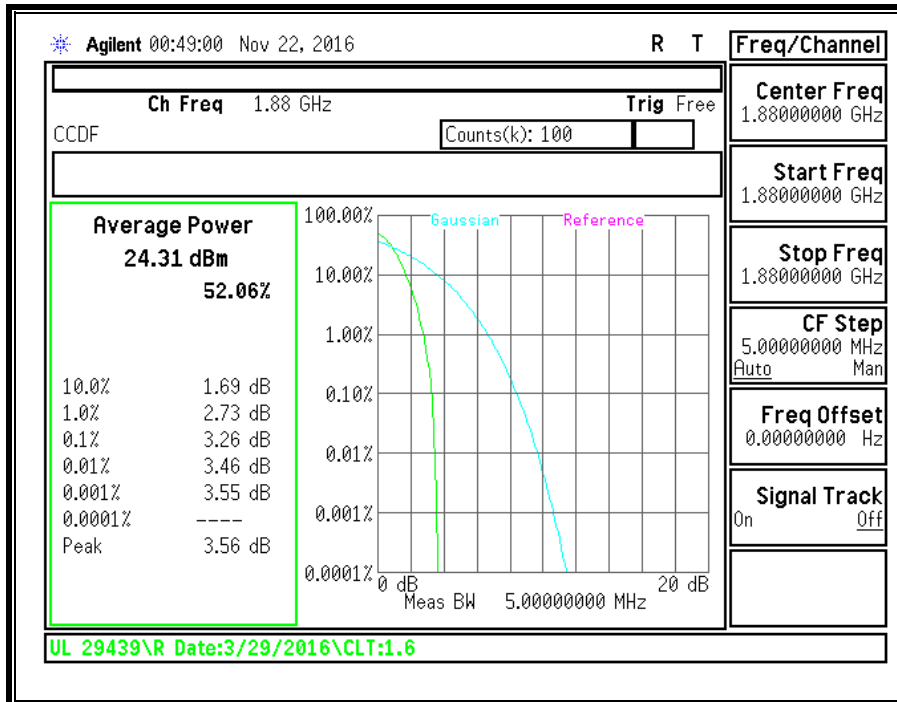

**UMTS 1700, REL99 BAND 4**

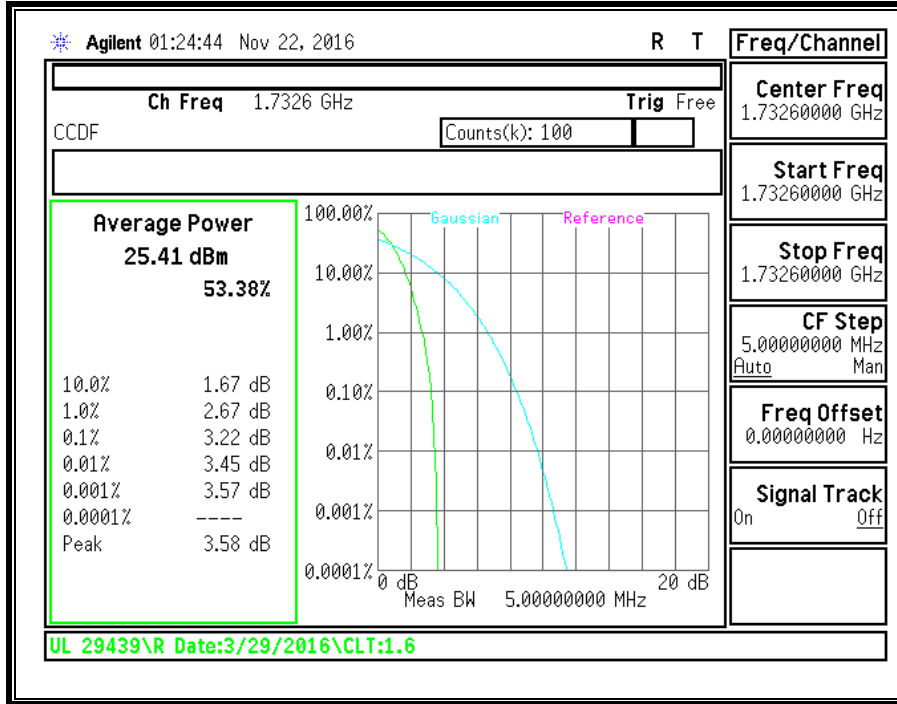

**UMTS 1700, HSDPA BAND 4**

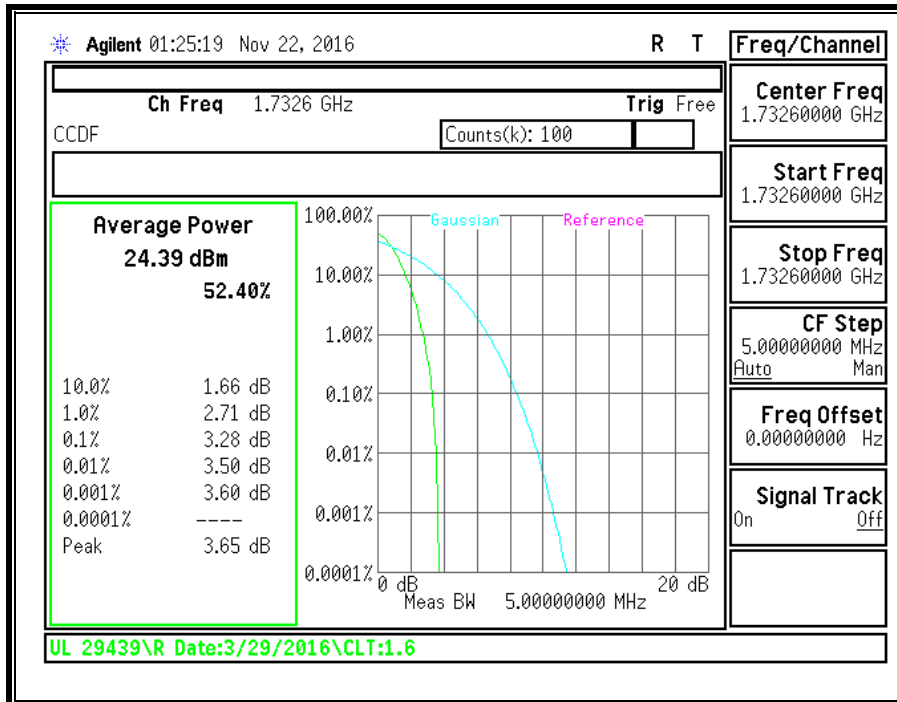

## 11. RADIATED TEST RESULTS

### 11.1. FIELD STRENGTH OF SPURIOUS RADIATION (ANTENNA C)

#### RULE PART(S)

FCC: §2.1053, §22.917, §24.238, §27.53 and §90.691.

IC: RSS132§5.5; RSS133§6.5 and RSS139§6.6

#### LIMIT

§22.917 (e) and §24.238 (a): Out of band emissions. The power of any emission outside of the authorized operating frequency ranges must be attenuated below the transmitting power (P) by a factor of at least  $43 + 10 \log (P)$  dB.

§27.53 (h) For operations in the 1710–1755 MHz and 2110–2155 MHz bands, the power of any emission outside a licensee's frequency block shall be attenuated below the transmitter power (P) by at least  $43 + 10 \log_{10}(P)$  dB

§90.691 Emission mask requirements for EA-based systems.

(a) Out-of-band emission requirement shall apply only to the “outer” channels included in an EA license and to spectrum adjacent to interior channels used by incumbent licensees. The emission limits are as follows:

(1) For any frequency removed from the EA licensee's frequency block by up to and including 37.5 kHz, the power of any emission shall be attenuated below the transmitter power (P) in watts by at least  $116 \text{ Log}_{10} (f/6.1)$  decibels or  $50 + 10 \text{ Log}_{10} (P)$  decibels or 80 decibels, whichever is the lesser attenuation, where f is the frequency removed from the center of the outer channel in the block in kilohertz and where f is greater than 12.5 kHz.

(2) For any frequency removed from the EA licensee's frequency block greater than 37.5 kHz, the power of any emission shall be attenuated below the transmitter power (P) in watts by at least  $43 + 10 \text{ Log}_{10} (P)$  decibels or 80 decibels, whichever is the lesser attenuation, where f is the frequency removed from the center of the outer channel in the block in kilohertz and where f is greater than 37.5 kHz.

(b) When an emission outside of the authorized bandwidth causes harmful interference, the Commission may, at its discretion, require greater attenuation than specified in this section.

#### RSS132§5.5

Mobile and base station equipment shall comply with the limits in (i) and (ii) below.

In the first 1.0 MHz band immediately outside and adjacent to each of the sub-bands specified in Section 5.1, the power of emissions per any 1% of the occupied bandwidth shall be attenuated (in dB) below the transmitter output power P ( dBW) by at least  $43 + 10 \log_{10} p$  (watts).

After the first 1.0 MHz immediately outside and adjacent to each of the sub-bands, the power of emissions in any 100 kHz bandwidth shall be attenuated (in dB) below the transmitter output power P (dBW) by at least  $43 + 10 \log_{10} p$  (watts). If the measurement is performed using 1% of the occupied bandwidth, power integration over 100 kHz is required.

#### RSS133§6.5

Equipment shall comply with the limits in (i) and (ii) below.

(i) In the 1.0 MHz bands immediately outside and adjacent to the equipment's operating frequency block, the emission power per any 1% of the emission bandwidth shall be attenuated (in dB) below the transmitter output power P (dBW) by at least  $43 + 10 \log_{10} p$  (watts).

(ii) After the first 1.0 MHz, the emission power in any 1 MHz bandwidth shall be attenuated (in dB) below the transmitter output power P (dBW) by at least  $43 + 10 \log_{10} p$  (watts). If the measurement is performed using 1% of the emission bandwidth, power integration over 1.0 MHz is required.

#### RSS139§6.6

(i) In the first 1.0 MHz bands immediately outside and adjacent to the equipment's smallest operating frequency block, Footnote 2 which can contain the equipment's occupied bandwidth, the emission power per any 1% of the emission bandwidth shall be attenuated below the transmitter output power P (in dBW) by at least  $43 + 10 \log_{10} p$  (watts) dB.

(ii) After the first 1.0 MHz outside the equipment's smallest operating frequency block, which can contain the equipment's occupied bandwidth, the emission power in any 1 MHz bandwidth shall be attenuated below the transmitter output power P (in dBW) by at least  $43 + 10 \log_{10} p$  (watts) dB.

### **TEST PROCEDURE**

For Cellular equipment - Compliance with these rules is based on the use of measurement instrumentation employing a resolution bandwidth of 100 kHz or greater. In the 1 MHz bands immediately outside and adjacent to the frequency block a resolution bandwidth of at least one percent of the emission bandwidth of the fundamental emission of the transmitter may be employed. A narrower resolution bandwidth is permitted in all cases to improve measurement accuracy provided the measured power is integrated over the full required measurement bandwidth ( i.e. 100 kHz or 1 percent of emission bandwidth, as specified). The emission bandwidth is defined as the width of the signal between two points, one below the carrier center frequency and one above the carrier center frequency, outside of which all emissions are attenuated at least 26 dB below the transmitter power.

For PCS equipment - Compliance with these rules is based on the use of measurement instrumentation employing a resolution bandwidth of 1 MHz or greater. However, in the 1 MHz bands immediately outside and adjacent to the frequency block a resolution bandwidth of at least one percent of the emission bandwidth of the fundamental emission of the transmitter may be employed. A narrower resolution bandwidth is permitted in all cases to improve measurement accuracy provided the measured power is integrated over the full required measurement bandwidth (i.e. 1 MHz or 1 percent of emission bandwidth, as specified). The emission bandwidth is defined as the width of the signal between two points, one below the carrier center frequency and one above the carrier center frequency, outside of which all emissions are attenuated at least 26 dB below the transmitter power.

### **MODES TESTED**

- GPRS/EGPRS
- UMTS, REL 99 and HSDPA
- CDMA2000, 1xRTT and EVDO, Rev A

### **RESULTS**

### 11.1.1. GSM

#### GPRS, 850MHz BAND 5

**High Frequency Substitution Measurement**  
**UL Fremont Radiated Chamber**

**Company:**  
**Project #:** 16U23816  
**Date:** 11/28/16  
**Test Engineer:** 45200  
**Configuration:** EUT only  
**Mode:** GPRS 850MHz

**Test Equipment:**  
**Substitution:** Horn T59 Substitution, and 8ft SMA Cable

Chamber

3m Chamber E

Pre-amplifier

3m Chamber E

Filter

Filter

Limit

EIRP

Frequency (GHz)	SA reading (dBm)	Ant. Pol. (H/V)	Distance	EIRP @ TX Ant End (dBm)	Preamp	Attenuator	EIRP	Limit	Delta	Notes
<b>Low Channel (824.2MHz)</b>										
1.65	-71.0	H	3.0	-28.5	37.8	1.0	-65.3	-13.0	-52.3	
2.47	-69.8	H	3.0	-24.8	38.5	1.0	-62.3	-13.0	-49.3	
3.29	-68.8	H	3.0	-19.9	38.5	1.0	-57.4	-13.0	-44.4	
1.65	-70.9	V	3.0	-28.8	37.8	1.0	-65.6	-13.0	-52.6	
2.47	-69.3	V	3.0	-24.1	38.5	1.0	-61.6	-13.0	-48.6	
3.30	-68.6	V	3.0	-19.9	38.5	1.0	-57.3	-13.0	-44.3	
<b>Mid Channel (836.6MHz)</b>										
1.67	-71.6	H	3.0	-29.1	37.8	1.0	-65.9	-13.0	-52.9	
2.51	-70.2	H	3.0	-24.9	38.6	1.0	-62.5	-13.0	-49.5	
3.35	-68.9	H	3.0	-19.8	38.5	1.0	-57.3	-13.0	-44.3	
1.67	-71.7	V	3.0	-29.4	37.8	1.0	-66.3	-13.0	-53.3	
2.51	-68.7	V	3.0	-23.3	38.6	1.0	-60.9	-13.0	-47.9	
3.35	-69.1	V	3.0	-20.3	38.5	1.0	-57.8	-13.0	-44.8	
<b>High Channel (848.8MHz)</b>										
1.70	-71.5	H	3.0	-29.0	37.9	1.0	-65.8	-13.0	-52.8	
2.54	-70.0	H	3.0	-24.6	38.6	1.0	-62.2	-13.0	-49.2	
3.40	-69.7	H	3.0	-20.5	38.5	1.0	-58.0	-13.0	-45.0	
1.70	-71.2	V	3.0	-28.8	37.9	1.0	-65.6	-13.0	-52.6	
2.55	-69.4	V	3.0	-23.8	38.6	1.0	-61.4	-13.0	-48.4	
3.39	-69.4	V	3.0	-20.4	38.5	1.0	-57.9	-13.0	-44.9	

Rev. 03.19.15

**EGPRS, 850MHz BAND 5**

**High Frequency Substitution Measurement  
 UL Fremont Radiated Chamber**

Company:  
 Project #: 16U23816  
 Date: 11/28/16  
 Test Engineer: 45200  
 Configuration: EUT only  
 Mode: EGPRS 850MHz

Test Equipment:  
 Substitution: Horn T59 Substitution, and 8ft SMA Cable

Chamber	Pre-amplifier	Filter	Limit
3m Chamber E	3m Chamber E	Filter	EIRP

Frequency (GHz)	SA reading (dBm)	Ant. Pol. (H/V)	Distance	EIRP @ TX Ant End (dBm)	Preamp	Attenuator	EIRP	Limit	Delta	Notes
<b>Low Channel (824.2MHz)</b>										
1.65	-71.2	H	3.0	-28.7	37.8	1.0	-65.6	-13.0	-52.6	
2.47	-69.7	H	3.0	-24.6	38.5	1.0	-62.1	-13.0	-49.1	
3.30	-69.9	H	3.0	-21.0	38.5	1.0	-58.4	-13.0	-45.4	
1.65	-71.5	V	3.0	-29.3	37.8	1.0	-66.2	-13.0	-53.2	
2.47	-69.1	V	3.0	-24.0	38.5	1.0	-61.4	-13.0	-48.4	
3.29	-68.5	V	3.0	-19.9	38.5	1.0	-57.3	-13.0	-44.3	
<b>Mid Channel (836.6MHz)</b>										
1.67	-71.4	H	3.0	-28.9	37.8	1.0	-65.7	-13.0	-52.7	
2.51	-69.2	H	3.0	-24.0	38.6	1.0	-61.5	-13.0	-48.5	
3.35	-69.3	H	3.0	-20.2	38.5	1.0	-57.7	-13.0	-44.7	
1.67	-71.1	V	3.0	-28.9	37.8	1.0	-65.7	-13.0	-52.7	
2.51	-69.2	V	3.0	-23.9	38.6	1.0	-61.4	-13.0	-48.4	
3.35	-68.2	V	3.0	-19.3	38.5	1.0	-56.8	-13.0	-43.8	
<b>High Channel (848.8MHz)</b>										
1.69	-70.9	H	3.0	-28.3	37.9	1.0	-65.2	-13.0	-52.2	
2.55	-70.2	H	3.0	-24.8	38.6	1.0	-62.3	-13.0	-49.3	
3.39	-69.8	H	3.0	-20.6	38.5	1.0	-58.1	-13.0	-45.1	
1.70	-71.6	V	3.0	-29.3	37.9	1.0	-66.1	-13.0	-53.1	
2.54	-69.5	V	3.0	-23.9	38.6	1.0	-61.5	-13.0	-48.5	
3.39	-69.0	V	3.0	-20.1	38.5	1.0	-57.6	-13.0	-44.6	

Rev. 03.19.15

**GPRS, 1900MHz BAND 2**

**High Frequency Substitution Measurement  
 UL Fremont Radiated Chamber**

**Company:**  
**Project #:** 16U23816  
**Date:** 11/28/16  
**Test Engineer:** 45200  
**Configuration:** EUT only  
**Mode:** GPRS 1900MHz

**Test Equipment:**  
 Substitution: Horn T59 Substitution, and 8ft SMA Cable

<b>Chamber</b>	<b>Pre-amplifier</b>	<b>Filter</b>	<b>Limit</b>
3m Chamber E	3m Chamber E	Filter	EIRP

Frequency (GHz)	SA reading (dBm)	Ant. Pol. (H/V)	Distance	EIRP @ TX Ant End (dBm)	Preamp	Attenuator	EIRP	Limit	Delta	Notes
<b>Low Channel (1850.2MHz)</b>										
3.70	-65.0	H	3.0	-15.1	38.6	1.0	-52.7	-13.0	-39.7	
5.56	-64.7	H	3.0	-10.7	38.6	1.0	-48.2	-13.0	-35.2	
7.40	-64.3	H	3.0	-6.6	37.8	1.0	-43.4	-13.0	-30.4	
3.70	-64.0	V	3.0	-14.1	38.6	1.0	-51.7	-13.0	-38.7	
5.55	-64.4	V	3.0	-10.6	38.6	1.0	-48.2	-13.0	-35.2	
7.40	-64.6	V	3.0	-7.2	37.8	1.0	-44.0	-13.0	-31.0	
<b>Mid Channel (1880.0)</b>										
3.75	-63.6	H	3.0	-13.5	38.6	1.0	-51.2	-13.0	-38.2	
5.64	-65.1	H	3.0	-10.8	38.5	1.0	-48.4	-13.0	-35.4	
7.53	-64.5	H	3.0	-6.7	37.7	1.0	-43.4	-13.0	-30.4	
3.76	-63.8	V	3.0	-13.7	38.6	1.0	-51.4	-13.0	-38.4	
5.64	-64.8	V	3.0	-10.9	38.5	1.0	-48.4	-13.0	-35.4	
7.52	-64.7	V	3.0	-7.1	37.7	1.0	-43.9	-13.0	-30.9	
<b>High Channel (1909.8MHz)</b>										
3.82	-63.2	H	3.0	-12.9	38.7	1.0	-50.5	-13.0	-37.5	
5.73	-64.1	H	3.0	-9.7	38.5	1.0	-47.2	-13.0	-34.2	
7.64	-65.3	H	3.0	-7.4	37.7	1.0	-44.0	-13.0	-31.0	
3.82	-62.9	V	3.0	-12.7	38.7	1.0	-50.3	-13.0	-37.3	
5.73	-63.7	V	3.0	-9.6	38.5	1.0	-47.1	-13.0	-34.1	
7.64	-65.3	V	3.0	-7.5	37.7	1.0	-44.2	-13.0	-31.2	

Rev. 03.19.15

**EGPRS, 1900MHz BAND 2**

**High Frequency Substitution Measurement  
 UL Fremont Radiated Chamber**

Company:  
 Project #: 16U23816  
 Date: 11/28/16  
 Test Engineer: 45200  
 Configuration: EUT only  
 Mode: EGPRS 1900MHz

**Test Equipment:**  
 Substitution: Horn T59 Substitution, and 8ft SMA Cable

<b>Chamber</b>	<b>Pre-amplifier</b>	<b>Filter</b>	<b>Limit</b>
3m Chamber E	3m Chamber E	Filter	EIRP

Frequency (GHz)	SA reading (dBm)	Ant. Pol. (H/V)	Distance	EIRP @ TX Ant End (dBm)	Preamp	Attenuator	EIRP	Limit	Delta	Notes
<b>Low Channel (1850.2MHz)</b>										
3.70	-63.5	H	3.0	-13.5	38.6	1.0	-51.2	-13.0	-38.2	
5.55	-64.9	H	3.0	-10.8	38.6	1.0	-48.4	-13.0	-35.4	
7.40	-65.1	H	3.0	-7.5	37.8	1.0	-44.3	-13.0	-31.3	
3.70	-63.2	V	3.0	-13.4	38.6	1.0	-51.0	-13.0	-38.0	
5.55	-64.8	V	3.0	-11.1	38.6	1.0	-48.7	-13.0	-35.7	
7.40	-65.1	V	3.0	-7.6	37.8	1.0	-44.4	-13.0	-31.4	
<b>Mid Channel (1880.0)</b>										
3.76	-63.5	H	3.0	-13.4	38.6	1.0	-51.0	-13.0	-38.0	
5.64	-65.5	H	3.0	-11.2	38.5	1.0	-48.7	-13.0	-35.7	
7.52	-64.3	H	3.0	-6.5	37.7	1.0	-43.3	-13.0	-30.3	
3.76	-63.5	V	3.0	-13.4	38.6	1.0	-51.0	-13.0	-38.0	
5.64	-65.6	V	3.0	-11.6	38.5	1.0	-49.2	-13.0	-36.2	
7.52	-64.6	V	3.0	-7.0	37.7	1.0	-43.7	-13.0	-30.7	
<b>High Channel (1909.8MHz)</b>										
3.81	-63.0	H	3.0	-12.7	38.7	1.0	-50.4	-13.0	-37.4	
5.73	-63.6	H	3.0	-9.1	38.5	1.0	-46.7	-13.0	-33.7	
7.64	-65.5	H	3.0	-7.5	37.7	1.0	-44.2	-13.0	-31.2	
3.82	-62.5	V	3.0	-12.3	38.7	1.0	-49.9	-13.0	-36.9	
5.72	-63.0	V	3.0	-8.9	38.5	1.0	-46.4	-13.0	-33.4	
7.64	-65.5	V	3.0	-7.8	37.7	1.0	-44.4	-13.0	-31.4	

Rev. 03.19.15

### 11.1.2. CDMA2000

#### CDMA2000 1xRTT, 850MHz BC0

#### High Frequency Substitution Measurement UL Fremont Radiated Chamber

Company:  
 Project #: 16U23814  
 Date: 11/17/16  
 Test Engineer: 37290  
 Configuration: EUT Only  
 Mode: 1xRTT 850MHz

Test Equipment:  
 Substitution: Horn T59 Substitution, and 8ft SMA Cable

Chamber	Pre-amplifier	Filter	Limit
3m Chamber E	3m Chamber E	Filter	EIRP

Frequency (GHz)	SA reading (dBm)	Ant. Pol. (H/V)	Distance	EIRP @ TX Ant End (dBm)	Preamp	Attenuator	EIRP	Limit	Delta	Notes
<b>Low Channel (824.7MHz)</b>										
1.65	-71.6	H	3.0	-29.1	37.8	1.0	-65.9	-13.0	-52.9	
2.48	-69.8	H	3.0	-24.8	38.5	1.0	-62.3	-13.0	-49.3	
3.30	-68.5	H	3.0	-19.5	38.5	1.0	-57.0	-13.0	-44.0	
1.65	-71.4	V	3.0	-29.3	37.8	1.0	-66.1	-13.0	-53.1	
2.47	-69.4	V	3.0	-24.2	38.5	1.0	-61.7	-13.0	-48.7	
3.30	-68.3	V	3.0	-19.6	38.5	1.0	-57.1	-13.0	-44.1	
<b>Mid Channel (836.52MHz)</b>										
1.67	-70.9	H	3.0	-28.4	37.8	1.0	-65.2	-13.0	-52.2	
2.51	-69.2	H	3.0	-24.0	38.6	1.0	-61.6	-13.0	-48.6	
3.35	-69.5	H	3.0	-20.5	38.5	1.0	-57.9	-13.0	-44.9	
1.67	-71.6	V	3.0	-29.3	37.8	1.0	-66.2	-13.0	-53.2	
2.51	-69.3	V	3.0	-23.9	38.6	1.0	-61.5	-13.0	-48.5	
3.34	-69.7	V	3.0	-20.9	38.5	1.0	-58.3	-13.0	-45.3	
<b>High Channel (848.31MHz)</b>										
1.70	-82.2	H	3.0	-39.6	37.9	1.0	-76.5	-13.0	-63.5	
2.54	-69.1	H	3.0	-23.7	38.6	1.0	-61.3	-13.0	-48.3	
3.40	-69.4	H	3.0	-20.2	38.5	1.0	-57.7	-13.0	-44.7	
1.70	-70.6	V	3.0	-28.2	37.9	1.0	-65.1	-13.0	-52.1	
2.54	-69.6	V	3.0	-24.1	38.6	1.0	-61.7	-13.0	-48.7	
3.39	-68.7	V	3.0	-19.8	38.5	1.0	-57.3	-13.0	-44.3	

Rev. 03.19.15

**CDMA2000 EVDO Rev A, 850MHz BC0**

**High Frequency Substitution Measurement  
 UL Fremont Radiated Chamber**

**Company:**  
**Project #:** 16U23816  
**Date:** 11/28/16  
**Test Engineer:** 52297  
**Configuration:** EUT only  
**Mode:** EVDO, Rev A 850MHz

**Test Equipment:**  
 Substitution: Horn T59 Substitution, and 8ft SMA Cable

<b>Chamber</b>	<b>Pre-amplifier</b>	<b>Filter</b>	<b>Limit</b>
3m Chamber D	3m Chamber D	Filter	EIRP

Frequency (GHz)	SA reading (dBm)	Ant. Pol. (H/V)	Distance	EIRP @ TX Ant End (dBm)	Preamp	Attenuator	EIRP	Limit	Delta	Notes
<b>Low Channel (824.7MHz)</b>										
1.65	-66.9	H	3.0	-25.2	35.0	1.0	-59.2	-13.0	-46.2	
2.47	-67.7	H	3.0	-23.6	33.9	1.0	-56.5	-13.0	-43.5	
3.30	-68.3	H	3.0	-21.6	33.2	1.0	-53.8	-13.0	-40.8	
1.65	-65.9	V	3.0	-23.9	35.0	1.0	-57.9	-13.0	-44.9	
2.48	-67.8	V	3.0	-23.5	33.9	1.0	-56.4	-13.0	-43.4	
3.30	-68.9	V	3.0	-22.1	33.2	1.0	-54.3	-13.0	-41.3	
<b>Mid Channel (836.52MHz)</b>										
1.67	-66.7	H	3.0	-24.9	35.0	1.0	-58.9	-13.0	-45.9	
2.51	-67.8	H	3.0	-23.5	33.7	1.0	-56.2	-13.0	-43.2	
3.35	-68.7	H	3.0	-21.8	33.3	1.0	-54.1	-13.0	-41.1	
1.67	-66.9	V	3.0	-24.8	35.0	1.0	-58.9	-13.0	-45.9	
2.51	-67.6	V	3.0	-23.1	33.7	1.0	-55.8	-13.0	-42.8	
3.35	-68.0	V	3.0	-21.0	33.3	1.0	-53.3	-13.0	-40.3	
<b>High Channel (848.31MHz)</b>										
1.70	-67.2	H	3.0	-25.3	35.0	1.0	-59.3	-13.0	-46.3	
2.55	-67.2	H	3.0	-22.7	33.7	1.0	-55.4	-13.0	-42.4	
3.40	-68.6	H	3.0	-21.5	33.3	1.0	-53.8	-13.0	-40.8	
1.70	-66.8	V	3.0	-24.7	35.0	1.0	-58.7	-13.0	-45.7	
2.54	-67.2	V	3.0	-22.6	33.7	1.0	-55.2	-13.0	-42.2	
3.40	-67.8	V	3.0	-20.7	33.3	1.0	-53.0	-13.0	-40.0	

Rev. 03.19.15

**CDMA2000 1xRTT, 1900MHz BC1**

**High Frequency Substitution Measurement  
 UL Fremont Radiated Chamber**

**Company:**  
**Project #:** 16U23816  
**Date:** 11/28/16  
**Test Engineer:** 52297  
**Configuration:** EUT only  
**Mode:** 1xRTT 1900MHz

**Test Equipment:**  
 Substitution: Horn T59 Substitution, and 8ft SMA Cable

<b>Chamber</b>	<b>Pre-amplifier</b>	<b>Filter</b>	<b>Limit</b>
3m Chamber E	3m Chamber E	Filter	EIRP

Frequency (GHz)	SA reading (dBm)	Ant. Pol. (H/V)	Distance	EIRP @ TX Ant End (dBm)	Preamp	Attenuator	EIRP	Limit	Delta	Notes
<b>Low Channel (1851.25MHz)</b>										
3.70	-56.5	H	3.0	-6.5	38.6	1.0	-44.1	-13.0	-31.1	
5.56	-66.7	H	3.0	-12.6	38.6	1.0	-50.2	-13.0	-37.2	
7.41	-68.4	H	3.0	-10.8	37.8	1.0	-47.6	-13.0	-34.6	
3.70	-64.1	V	3.0	-14.2	38.6	1.0	-51.9	-13.0	-38.9	
5.55	-63.9	V	3.0	-10.1	38.6	1.0	-47.7	-13.0	-34.7	
7.40	-64.7	V	3.0	-7.2	37.8	1.0	-44.1	-13.0	-31.1	
<b>Mid Channel (1880MHz)</b>										
3.76	-57.0	H	3.0	-6.9	38.6	1.0	-44.5	-13.0	-31.5	
5.64	-64.5	H	3.0	-10.2	38.5	1.0	-47.7	-13.0	-34.7	
7.52	-65.3	H	3.0	-7.5	37.7	1.0	-44.2	-13.0	-31.2	
3.76	-62.0	V	3.0	-11.9	38.6	1.0	-49.5	-13.0	-36.5	
5.64	-64.8	V	3.0	-10.8	38.5	1.0	-48.4	-13.0	-35.4	
7.52	-64.5	V	3.0	-6.9	37.7	1.0	-43.6	-13.0	-30.6	
<b>High Channel (1908.75MHz)</b>										
3.82	-60.1	H	3.0	-9.8	38.7	1.0	-47.5	-13.0	-34.5	
5.73	-64.6	H	3.0	-10.2	38.5	1.0	-47.7	-13.0	-34.7	
7.64	-65.7	H	3.0	-7.8	37.7	1.0	-44.5	-13.0	-31.5	
3.82	-61.6	V	3.0	-11.4	38.7	1.0	-49.1	-13.0	-36.1	
5.72	-63.4	V	3.0	-9.3	38.5	1.0	-46.8	-13.0	-33.8	
7.63	-65.4	V	3.0	-7.6	37.7	1.0	-44.3	-13.0	-31.3	

Rev. 03.19.15

**CDMA2000 EVDO Rev A, 1900MHz BC1**

**High Frequency Substitution Measurement  
 UL Fremont Radiated Chamber**

**Company:**  
**Project #:** 16U23816  
**Date:** 11/28/16  
**Test Engineer:** 52297  
**Configuration:** EUT only  
**Mode:** Rev 0/A 1900MHz

**Test Equipment:**  
 Substitution: Horn T59 Substitution, and 8ft SMA Cable

<b>Chamber</b>	<b>Pre-amplifier</b>	<b>Filter</b>	<b>Limit</b>
3m Chamber D	3m Chamber D	Filter	EIRP

Frequency (GHz)	SA reading (dBm)	Ant. Pol. (H/V)	Distance	EIRP @ TX Ant End (dBm)	Preamp	Attenuator	EIRP	Limit	Delta	Notes
<b>Low Channel (1851.25MHz)</b>										
3.70	-60.3	H	3.0	-12.4	33.5	1.0	-44.9	-13.0	-31.9	
5.55	-69.8	H	3.0	-18.5	32.5	1.0	-50.0	-13.0	-37.0	
7.40	-70.8	H	3.0	-16.5	30.4	1.0	-45.9	-13.0	-32.9	
3.70	-58.7	V	3.0	-10.7	33.5	1.0	-43.2	-13.0	-30.2	
5.55	-69.2	V	3.0	-18.2	32.5	1.0	-49.7	-13.0	-36.7	
7.40	-70.5	V	3.0	-15.9	30.4	1.0	-45.3	-13.0	-32.3	
<b>Mid Channel (1880MHz)</b>										
3.76	-59.9	H	3.0	-11.8	33.5	1.0	-44.4	-13.0	-31.4	
5.64	-68.8	H	3.0	-17.3	32.4	1.0	-48.7	-13.0	-35.7	
7.52	-70.3	H	3.0	-15.8	30.3	1.0	-45.0	-13.0	-32.0	
3.76	-58.6	V	3.0	-10.5	33.5	1.0	-43.0	-13.0	-30.0	
5.64	-69.7	V	3.0	-18.5	32.4	1.0	-49.9	-13.0	-36.9	
7.52	-68.9	V	3.0	-14.2	30.3	1.0	-43.5	-13.0	-30.5	
<b>High Channel (1908.75MHz)</b>										
3.82	-64.2	H	3.0	-15.9	33.6	1.0	-48.5	-13.0	-35.5	
5.72	-69.2	H	3.0	-17.6	32.3	1.0	-48.9	-13.0	-35.9	
7.63	-70.4	H	3.0	-15.8	30.1	1.0	-44.9	-13.0	-31.9	
3.82	-61.9	V	3.0	-13.7	33.6	1.0	-46.3	-13.0	-33.3	
5.73	-68.3	V	3.0	-16.9	32.3	1.0	-48.2	-13.0	-35.2	
7.63	-70.8	V	3.0	-16.1	30.1	1.0	-45.2	-13.0	-32.2	

Rev. 03.19.15

**CDMA2000 1xRTT, 800MHz BC10**

**High Frequency Substitution Measurement  
 UL Fremont Radiated Chamber**

Company:  
 Project #: 16U23816  
 Date: 11/28/16  
 Test Engineer: 45200  
 Configuration: EUT only  
 Mode: 1xRTT 800MHz

**Test Equipment:**  
 Substitution: Horn T59 Substitution, and 8ft SMA Cable

<b>Chamber</b>	<b>Pre-amplifier</b>	<b>Filter</b>	<b>Limit</b>
3m Chamber E	3m Chamber E	Filter	EIRP

Frequency (GHz)	SA reading (dBm)	Ant. Pol. (H/V)	Distance	EIRP @ TX Ant End (dBm)	Preamp	Attenuator	EIRP	Limit	Delta	Notes
<b>Low Channel (817.25MHz)</b>										
1.63	-71.4	H	3.0	-29.0	37.8	1.0	-65.8	-13.0	-52.8	
2.45	-69.4	H	3.0	-24.5	38.4	1.0	-61.9	-13.0	-48.9	
3.27	-69.1	H	3.0	-20.2	38.5	1.0	-57.7	-13.0	-44.7	
1.63	-71.9	V	3.0	-29.9	37.8	1.0	-66.7	-13.0	-53.7	
2.45	-69.4	V	3.0	-24.3	38.4	1.0	-61.7	-13.0	-48.7	
3.27	-68.8	V	3.0	-20.2	38.5	1.0	-57.7	-13.0	-44.7	
<b>Mid Channel (820MHz)</b>										
1.64	-71.1	H	3.0	-28.7	37.8	1.0	-65.5	-13.0	-52.5	
2.46	-70.0	H	3.0	-25.0	38.4	1.0	-62.4	-13.0	-49.4	
3.28	-68.1	H	3.0	-19.1	38.5	1.0	-56.6	-13.0	-43.6	
1.64	-71.6	V	3.0	-29.5	37.8	1.0	-66.3	-13.0	-53.3	
2.46	-69.5	V	3.0	-24.4	38.4	1.0	-61.8	-13.0	-48.8	
3.28	-69.7	V	3.0	-21.1	38.5	1.0	-58.5	-13.0	-45.5	
<b>High Channel (822.75MHz)</b>										
1.65	-71.5	H	3.0	-29.1	37.8	1.0	-65.9	-13.0	-52.9	
2.47	-70.0	H	3.0	-25.0	38.4	1.0	-62.4	-13.0	-49.4	
3.29	-69.2	H	3.0	-20.2	38.5	1.0	-57.7	-13.0	-44.7	
1.65	-71.8	V	3.0	-29.7	37.8	1.0	-66.5	-13.0	-53.5	
2.47	-69.4	V	3.0	-24.3	38.5	1.0	-61.7	-13.0	-48.7	
3.29	-68.5	V	3.0	-19.8	38.5	1.0	-57.3	-13.0	-44.3	

Rev. 03.19.15

**CDMA2000 EVDO Rev A, 800MHz BC10**

**High Frequency Substitution Measurement  
 UL Fremont Radiated Chamber**

**Company:**  
**Project #:** 16U23816  
**Date:** 11/28/16  
**Test Engineer:** 52297  
**Configuration:** EUT only  
**Mode:** EVDO, Rev A, 800MHz

**Test Equipment:**  
 Substitution: Horn T59 Substitution, and 8ft SMA Cable

<b>Chamber</b>	<b>Pre-amplifier</b>	<b>Filter</b>	<b>Limit</b>
3m Chamber D	3m Chamber D	Filter	EIRP

Frequency (GHz)	SA reading (dBm)	Ant. Pol. (H/V)	Distance	EIRP @ TX Ant End (dBm)	Preamp	Attenuator	EIRP	Limit	Delta	Notes
<b>Low Channel (817.25MHz)</b>										
1.63	-66.5	H	3.0	-24.8	35.0	1.0	-58.8	-13.0	-45.8	
2.45	-67.6	H	3.0	-23.6	34.1	1.0	-56.6	-13.0	-43.6	
3.27	-68.1	H	3.0	-21.4	33.2	1.0	-53.6	-13.0	-40.6	
1.63	-65.5	V	3.0	-23.5	35.0	1.0	-57.5	-13.0	-44.5	
2.45	-67.4	V	3.0	-23.2	34.1	1.0	-56.2	-13.0	-43.2	
3.27	-68.4	V	3.0	-21.6	33.2	1.0	-53.8	-13.0	-40.8	
<b>Mid Channel (820MHz)</b>										
1.64	-65.9	H	3.0	-24.1	35.0	1.0	-58.1	-13.0	-45.1	
2.46	-67.3	H	3.0	-23.2	34.0	1.0	-56.2	-13.0	-43.2	
3.28	-68.0	H	3.0	-21.3	33.2	1.0	-53.5	-13.0	-40.5	
1.64	-65.1	V	3.0	-23.1	35.0	1.0	-57.1	-13.0	-44.1	
2.46	-67.8	V	3.0	-23.5	34.0	1.0	-56.5	-13.0	-43.5	
3.28	-68.3	V	3.0	-21.5	33.2	1.0	-53.7	-13.0	-40.7	
<b>High Channel (822.75MHz)</b>										
1.64	-67.2	H	3.0	-25.4	35.0	1.0	-59.4	-13.0	-46.4	
2.47	-67.7	H	3.0	-23.6	33.9	1.0	-56.6	-13.0	-43.6	
3.29	-67.7	H	3.0	-20.9	33.2	1.0	-53.1	-13.0	-40.1	
1.65	-66.7	V	3.0	-24.8	35.0	1.0	-58.8	-13.0	-45.8	
2.47	-67.9	V	3.0	-23.6	34.0	1.0	-56.5	-13.0	-43.5	
3.29	-68.8	V	3.0	-21.9	33.2	1.0	-54.1	-13.0	-41.1	

Rev. 03.19.15

### 11.1.3. UMTS

#### UMTS REL 99, 850MHz BAND 5

#### High Frequency Substitution Measurement UL Fremont Radiated Chamber

Company:  
 Project #: 16U23816  
 Date: 11/28/16  
 Test Engineer: 45200  
 Configuration: EUT only  
 Mode: REL 99, 850MHz

Test Equipment:  
 Substitution: Horn T59 Substitution, and 8ft SMA Cable

<b>Chamber</b>	<b>Pre-amplifier</b>	<b>Filter</b>	<b>Limit</b>
3m Chamber E	3m Chamber E	Filter	EIRP

Frequency (GHz)	SA reading (dBm)	Ant. Pol. (H/V)	Distance	EIRP @ TX Ant End (dBm)	Preamp	Attenuator	EIRP	Limit	Delta	Notes
<b>Low Channel (826.4MHz)</b>										
1.65	-70.2	H	3.0	-27.8	37.8	1.0	-64.6	-13.0	-51.6	
2.47	-69.9	H	3.0	-24.9	38.5	1.0	-62.4	-13.0	-49.4	
3.30	-68.8	H	3.0	-19.9	38.5	1.0	-57.4	-13.0	-44.4	
1.65	-71.2	V	3.0	-29.1	37.8	1.0	-65.9	-13.0	-52.9	
2.47	-68.9	V	3.0	-23.7	38.5	1.0	-61.2	-13.0	-48.2	
3.31	-68.9	V	3.0	-20.2	38.5	1.0	-57.6	-13.0	-44.6	
<b>Mid Channel (836.6MHz)</b>										
1.67	-70.9	H	3.0	-28.4	37.8	1.0	-65.2	-13.0	-52.2	
2.50	-69.7	H	3.0	-24.5	38.6	1.0	-62.1	-13.0	-49.1	
3.35	-68.7	H	3.0	-19.6	38.5	1.0	-57.1	-13.0	-44.1	
1.66	-71.5	V	3.0	-29.3	37.8	1.0	-66.2	-13.0	-53.2	
2.51	-69.6	V	3.0	-24.2	38.6	1.0	-61.8	-13.0	-48.8	
3.34	-69.1	V	3.0	-20.3	38.5	1.0	-57.8	-13.0	-44.8	
<b>High Channel (846.6MHz)</b>										
1.70	-71.5	H	3.0	-28.9	37.9	1.0	-65.8	-13.0	-52.8	
2.55	-69.1	H	3.0	-23.6	38.6	1.0	-61.2	-13.0	-48.2	
3.40	-68.6	H	3.0	-19.4	38.5	1.0	-56.9	-13.0	-43.9	
1.70	-71.3	V	3.0	-28.9	37.9	1.0	-65.8	-13.0	-52.8	
2.53	-68.8	V	3.0	-23.3	38.6	1.0	-60.9	-13.0	-47.9	
3.38	-68.9	V	3.0	-20.0	38.5	1.0	-57.5	-13.0	-44.5	

Rev. 03.19.15

**UMTS HSDPA, 850MHz BAND 5**

**High Frequency Substitution Measurement  
 UL Fremont Radiated Chamber**

**Company:**  
**Project #:** 16U23816  
**Date:** 11/28/16  
**Test Engineer:** 45200  
**Configuration:** EUT only  
**Mode:** HSDPA 850MHz

**Test Equipment:**  
 Substitution: Horn T59 Substitution, and 8ft SMA Cable

<b>Chamber</b>	<b>Pre-amplifier</b>	<b>Filter</b>	<b>Limit</b>
3m Chamber E	3m Chamber E	Filter	EIRP

Frequency (GHz)	SA reading (dBm)	Ant. Pol. (H/V)	Distance	EIRP @ TX Ant End (dBm)	Preamp	Attenuator	EIRP	Limit	Delta	Notes
<b>Low Channel (826.4MHz)</b>										
1.65	-71.4	H	3.0	-29.0	37.8	1.0	-65.8	-13.0	-52.8	
2.49	-69.3	H	3.0	-24.3	38.5	1.0	-61.8	-13.0	-48.8	
3.30	-69.1	H	3.0	-20.1	38.5	1.0	-57.6	-13.0	-44.6	
1.64	-71.5	V	3.0	-29.4	37.8	1.0	-66.3	-13.0	-53.3	
2.48	-69.2	V	3.0	-24.0	38.5	1.0	-61.4	-13.0	-48.4	
3.31	-69.1	V	3.0	-20.4	38.5	1.0	-57.9	-13.0	-44.9	
<b>Mid Channel (836.6MHz)</b>										
1.68	-70.9	H	3.0	-28.4	37.9	1.0	-65.2	-13.0	-52.2	
2.51	-69.4	H	3.0	-24.1	38.6	1.0	-61.7	-13.0	-48.7	
3.34	-69.1	H	3.0	-20.0	38.5	1.0	-57.5	-13.0	-44.5	
1.68	-71.7	V	3.0	-29.4	37.9	1.0	-66.3	-13.0	-53.3	
2.50	-69.2	V	3.0	-23.8	38.6	1.0	-61.4	-13.0	-48.4	
3.34	-69.2	V	3.0	-20.4	38.5	1.0	-57.9	-13.0	-44.9	
<b>High Channel (846.6MHz)</b>										
1.70	-71.6	H	3.0	-29.0	37.9	1.0	-65.9	-13.0	-52.9	
2.53	-69.6	H	3.0	-24.2	38.6	1.0	-61.8	-13.0	-48.8	
3.38	-69.1	H	3.0	-20.0	38.5	1.0	-57.5	-13.0	-44.5	
1.69	-71.0	V	3.0	-28.7	37.9	1.0	-65.5	-13.0	-52.5	
2.54	-69.2	V	3.0	-23.7	38.6	1.0	-61.2	-13.0	-48.2	
3.38	-69.2	V	3.0	-20.3	38.5	1.0	-57.8	-13.0	-44.8	

Rev. 03.19.15

**UMTS REL 99, 1900MHz BAND 2**

**High Frequency Substitution Measurement  
 UL Fremont Radiated Chamber**

**Company:**  
**Project #:** 16U23816  
**Date:** 11/28/16  
**Test Engineer:** 45200  
**Configuration:** EUT only  
**Mode:** REL 99, 1900MHz

**Test Equipment:**

Substitution: Horn T59 Substitution, and 8ft SMA Cable

<b>Chamber</b>	<b>Pre-amplifier</b>	<b>Filter</b>	<b>Limit</b>
3m Chamber E	3m Chamber E	Filter	EIRP

Frequency (GHz)	SA reading (dBm)	Ant. Pol. (H/V)	Distance	EIRP @ TX Ant End (dBm)	Preamp	Attenuator	EIRP	Limit	Delta	Notes
<b>Low Channel (1852.4MHz)</b>										
3.71	-61.3	H	3.0	-11.3	38.6	1.0	-48.9	-13.0	-35.9	
5.55	-63.4	H	3.0	-9.4	38.6	1.0	-46.9	-13.0	-33.9	
7.41	-64.2	H	3.0	-6.5	37.8	1.0	-43.3	-13.0	-30.3	
3.71	-64.3	V	3.0	-14.4	38.6	1.0	-52.0	-13.0	-39.0	
5.55	-63.7	V	3.0	-9.9	38.6	1.0	-47.5	-13.0	-34.5	
7.41	-65.0	V	3.0	-7.6	37.8	1.0	-44.4	-13.0	-31.4	
<b>Mid Channel (1880MHz)</b>										
3.76	-60.3	H	3.0	-10.2	38.6	1.0	-47.9	-13.0	-34.9	
5.64	-64.6	H	3.0	-10.4	38.5	1.0	-47.9	-13.0	-34.9	
7.52	-64.9	H	3.0	-7.1	37.7	1.0	-43.8	-13.0	-30.8	
3.76	-63.3	V	3.0	-13.3	38.6	1.0	-50.9	-13.0	-37.9	
5.64	-64.4	V	3.0	-10.5	38.5	1.0	-48.0	-13.0	-35.0	
7.52	-64.4	V	3.0	-6.7	37.7	1.0	-43.5	-13.0	-30.5	
<b>High Channel (1907.6MHz)</b>										
3.81	-61.4	H	3.0	-11.2	38.7	1.0	-48.8	-13.0	-35.8	
5.72	-64.0	H	3.0	-9.6	38.5	1.0	-47.1	-13.0	-34.1	
7.63	-64.8	H	3.0	-6.9	37.7	1.0	-43.6	-13.0	-30.6	
3.81	-62.9	V	3.0	-12.7	38.7	1.0	-50.4	-13.0	-37.4	
5.72	-63.6	V	3.0	-9.5	38.5	1.0	-47.0	-13.0	-34.0	
7.63	-65.6	V	3.0	-7.9	37.7	1.0	-44.6	-13.0	-31.6	

Rev. 03.19.15

**UMTS HSDPA, 1900MHz BAND 2**

**High Frequency Substitution Measurement  
 UL Fremont Radiated Chamber**

**Company:**  
**Project #:** 16U23816  
**Date:** 11/28/16  
**Test Engineer:** 45200  
**Configuration:** EUT only  
**Mode:** HSDPA 1900MHz

**Test Equipment:**  
 Substitution: Horn T59 Substitution, and 8ft SMA Cable

<b>Chamber</b>	<b>Pre-amplifier</b>	<b>Filter</b>	<b>Limit</b>
3m Chamber E	3m Chamber E	Filter	EIRP

Frequency (GHz)	SA reading (dBm)	Ant. Pol. (H/V)	Distance	EIRP @ TX Ant End (dBm)	Preamp	Attenuator	EIRP	Limit	Delta	Notes
<b>Low Channel (1852.4MHz)</b>										
3.71	-62.5	H	3.0	-12.5	38.6	1.0	-50.1	-13.0	-37.1	
5.55	-63.8	H	3.0	-9.7	38.6	1.0	-47.3	-13.0	-34.3	
7.41	-64.9	H	3.0	-7.2	37.8	1.0	-44.0	-13.0	-31.0	
3.71	-62.3	V	3.0	-12.4	38.6	1.0	-50.0	-13.0	-37.0	
5.55	-64.1	V	3.0	-10.4	38.6	1.0	-48.0	-13.0	-35.0	
7.41	-64.4	V	3.0	-6.9	37.8	1.0	-43.8	-13.0	-30.8	
<b>Mid Channel (1880MHz)</b>										
3.76	-61.8	H	3.0	-11.7	38.6	1.0	-49.3	-13.0	-36.3	
5.64	-64.4	H	3.0	-10.2	38.5	1.0	-47.7	-13.0	-34.7	
7.52	-64.3	H	3.0	-6.5	37.7	1.0	-43.2	-13.0	-30.2	
3.76	-61.0	V	3.0	-10.9	38.6	1.0	-48.6	-13.0	-35.6	
5.64	-65.2	V	3.0	-11.3	38.5	1.0	-48.8	-13.0	-35.8	
7.52	-65.5	V	3.0	-7.8	37.7	1.0	-44.6	-13.0	-31.6	
<b>High Channel (1907.6MHz)</b>										
3.81	-60.7	H	3.0	-10.5	38.7	1.0	-48.1	-13.0	-35.1	
5.72	-64.1	H	3.0	-9.7	38.5	1.0	-47.2	-13.0	-34.2	
7.63	-65.5	H	3.0	-7.5	37.7	1.0	-44.2	-13.0	-31.2	
3.81	-61.3	V	3.0	-11.1	38.7	1.0	-48.7	-13.0	-35.7	
5.72	-63.5	V	3.0	-9.4	38.5	1.0	-46.9	-13.0	-33.9	
7.63	-65.7	V	3.0	-8.0	37.7	1.0	-44.6	-13.0	-31.6	

Rev. 03.19.15

**UMTS REL 99, 1700MHz BAND 4**

**High Frequency Substitution Measurement  
 UL Fremont Radiated Chamber**

**Company:**  
**Project #:** 16U23816  
**Date:** 11/28/16  
**Test Engineer:** 45200  
**Configuration:** EUT only  
**Mode:** REL 99, 1700MHz

**Test Equipment:**  
 Substitution: Horn T59 Substitution, and 8ft SMA Cable

<b>Chamber</b>	<b>Pre-amplifier</b>	<b>Filter</b>	<b>Limit</b>
3m Chamber E	3m Chamber E	Filter	EIRP

Frequency (GHz)	SA reading (dBm)	Ant. Pol. (H/V)	Distance	EIRP @ TX Ant End (dBm)	Preamp	Attenuator	EIRP	Limit	Delta	Notes
<b>Low Channel (1712.4MHz)</b>										
3.43	-63.6	H	3.0	-14.4	38.5	1.0	-51.9	-13.0	-38.9	
5.13	-64.3	H	3.0	-11.1	38.7	1.0	-48.8	-13.0	-35.8	
6.85	-64.8	H	3.0	-7.9	38.1	1.0	-45.1	-13.0	-32.1	
3.43	-62.7	V	3.0	-13.6	38.5	1.0	-51.1	-13.0	-38.1	
5.14	-64.2	V	3.0	-11.4	38.7	1.0	-49.1	-13.0	-36.1	
6.85	-64.4	V	3.0	-7.8	38.1	1.0	-44.9	-13.0	-31.9	
<b>Mid Channel (1732.6MHz)</b>										
3.47	-64.2	H	3.0	-14.8	38.5	1.0	-52.4	-13.0	-39.4	
5.19	-64.3	H	3.0	-11.0	38.7	1.0	-48.7	-13.0	-35.7	
6.93	-64.2	H	3.0	-7.1	38.1	1.0	-44.2	-13.0	-31.2	
3.46	-63.8	V	3.0	-14.6	38.5	1.0	-52.2	-13.0	-39.2	
5.20	-63.4	V	3.0	-10.5	38.7	1.0	-48.2	-13.0	-35.2	
6.94	-63.9	V	3.0	-7.1	38.1	1.0	-44.2	-13.0	-31.2	
<b>High Channel (1752.6MHz)</b>										
3.50	-63.0	H	3.0	-13.5	38.5	1.0	-51.1	-13.0	-38.1	
5.26	-64.0	H	3.0	-10.5	38.7	1.0	-48.2	-13.0	-35.2	
7.01	-66.0	H	3.0	-8.8	38.1	1.0	-45.8	-13.0	-32.8	
3.50	-60.9	V	3.0	-11.6	38.5	1.0	-49.2	-13.0	-36.2	
5.26	-63.9	V	3.0	-10.8	38.7	1.0	-48.4	-13.0	-35.4	
7.01	-65.1	V	3.0	-8.1	38.1	1.0	-45.2	-13.0	-32.2	

Rev. 03.19.15

**UMTS HSDPA, 1700MHz BAND 4**

**High Frequency Substitution Measurement  
 UL Fremont Radiated Chamber**

**Company:**  
**Project #:** 16U23816  
**Date:** 11/28/16  
**Test Engineer:** 45200  
**Configuration:** EUT only  
**Mode:** HSDPA 1700MHz

**Test Equipment:**  
 Substitution: Horn T59 Substitution, and 8ft SMA Cable

<b>Chamber</b>	<b>Pre-amplifier</b>	<b>Filter</b>	<b>Limit</b>
3m Chamber E	3m Chamber E	Filter	EIRP

Frequency (GHz)	SA reading (dBm)	Ant. Pol. (H/V)	Distance	EIRP @ TX Ant End (dBm)	Preamp	Attenuator	EIRP	Limit	Delta	Notes
<b>Low Channel (1712.4MHz)</b>										
3.43	-62.6	H	3.0	-13.4	38.5	1.0	-50.9	-13.0	-37.9	
5.14	-63.2	H	3.0	-10.0	38.7	1.0	-47.7	-13.0	-34.7	
6.85	-64.3	H	3.0	-7.5	38.1	1.0	-44.6	-13.0	-31.6	
3.42	-62.3	V	3.0	-13.2	38.5	1.0	-50.7	-13.0	-37.7	
5.14	-64.1	V	3.0	-11.3	38.7	1.0	-49.0	-13.0	-36.0	
6.85	-64.1	V	3.0	-7.5	38.1	1.0	-44.6	-13.0	-31.6	
<b>Mid Channel (1732.6MHz)</b>										
3.47	-62.8	H	3.0	-13.5	38.5	1.0	-51.0	-13.0	-38.0	
5.20	-63.6	H	3.0	-10.3	38.7	1.0	-48.0	-13.0	-35.0	
6.93	-64.0	H	3.0	-7.0	38.1	1.0	-44.1	-13.0	-31.1	
3.46	-64.4	V	3.0	-15.2	38.5	1.0	-52.7	-13.0	-39.7	
5.20	-63.8	V	3.0	-10.9	38.7	1.0	-48.5	-13.0	-35.5	
6.93	-64.0	V	3.0	-7.3	38.1	1.0	-44.4	-13.0	-31.4	
<b>High Channel (1752.6MHz)</b>										
3.50	-61.4	H	3.0	-12.0	38.5	1.0	-49.5	-13.0	-36.5	
5.25	-64.2	H	3.0	-10.8	38.7	1.0	-48.4	-13.0	-35.4	
7.01	-65.3	H	3.0	-8.1	38.1	1.0	-45.1	-13.0	-32.1	
3.50	-61.7	V	3.0	-12.4	38.5	1.0	-50.0	-13.0	-37.0	
5.26	-63.3	V	3.0	-10.2	38.7	1.0	-47.9	-13.0	-34.9	
7.01	-65.4	V	3.0	-8.5	38.1	1.0	-45.6	-13.0	-32.6	

Rev. 03.19.15

## 11.2. FIELD STRENGTH OF SPURIOUS RADIATION (ANTENNA D)

### 11.2.1. GSM

#### GPRS, 850MHz BAND 5

**High Frequency Substitution Measurement**  
**UL Fremont Radiated Chamber**

**Company:**  
**Project #:** 16U23816  
**Date:** 12/08/16  
**Test Engineer:** 43574  
**Configuration:** EUT only  
**Mode:** GPRS 850MHz

**Test Equipment:**  
 Substitution: Horn T59 Substitution, and 8ft SMA Cable

Chamber

Pre-amplifier

Filter

Limit

3m Chamber G

3m Chamber G

Filter

EIRP

Frequency (GHz)	SA reading (dBm)	Ant. Pol. (H/V)	Distance	EIRP @ TX Ant End (dBm)	Preamp	Attenuator	EIRP	Limit	Delta	Notes
<b>Low Channel (824.2MHz)</b>										
1.65	-67.4	H	3.0	-26.0	37.8	1.0	-62.8	-13.0	-49.8	
2.47	-66.9	H	3.0	-23.8	36.6	1.0	-59.4	-13.0	-46.4	
3.29	-68.9	H	3.0	-22.9	36.5	1.0	-58.5	-13.0	-45.5	
1.65	-67.5	V	3.0	-25.7	37.8	1.0	-62.5	-13.0	-49.5	
2.47	-66.8	V	3.0	-22.8	36.6	1.0	-58.3	-13.0	-45.3	
3.30	-68.9	V	3.0	-23.0	36.5	1.0	-58.5	-13.0	-45.5	
<b>Mid Channel (836.6MHz)</b>										
1.67	-67.6	H	3.0	-26.1	37.8	1.0	-62.9	-13.0	-49.9	
2.51	-68.7	H	3.0	-25.5	36.4	1.0	-60.8	-13.0	-47.8	
3.35	-69.3	H	3.0	-23.2	36.5	1.0	-58.7	-13.0	-45.7	
1.67	-67.5	V	3.0	-25.7	37.8	1.0	-62.5	-13.0	-49.5	
2.51	-68.2	V	3.0	-23.9	36.4	1.0	-59.3	-13.0	-46.3	
3.35	-70.0	V	3.0	-23.9	36.5	1.0	-59.4	-13.0	-46.4	
<b>High Channel (848.8MHz)</b>										
1.70	-67.3	H	3.0	-25.8	37.8	1.0	-62.6	-13.0	-49.6	
2.54	-68.6	H	3.0	-25.3	36.4	1.0	-60.7	-13.0	-47.7	
3.40	-69.8	H	3.0	-23.7	36.4	1.0	-59.1	-13.0	-46.1	
1.70	-67.5	V	3.0	-25.7	37.8	1.0	-62.5	-13.0	-49.5	
2.55	-68.3	V	3.0	-24.1	36.4	1.0	-59.5	-13.0	-46.5	
3.39	-69.5	V	3.0	-23.3	36.4	1.0	-58.8	-13.0	-45.8	

Rev. 03.19.15

**EGPRS, 850MHz BAND 5**

**High Frequency Substitution Measurement  
 UL Fremont Radiated Chamber**

**Company:**  
**Project #:** 16U23816  
**Date:** 12/08/16  
**Test Engineer:** 43574  
**Configuration:** EUT Only  
**Mode:** EGPRS 850MHz

**Test Equipment:**  
 Substitution: Horn T59 Substitution, and 8ft SMA Cable

<b>Chamber</b>	<b>Pre-amplifier</b>	<b>Filter</b>	<b>Limit</b>
3m Chamber G	3m Chamber G	Filter	EIRP

Frequency (GHz)	SA reading (dBm)	Ant. Pol. (H/V)	Distance	EIRP @ TX Ant End (dBm)	Preamp	Attenuator	EIRP	Limit	Delta	Notes
<b>Low Channel (824.2MHz)</b>										
1.65	-68.0	H	3.0	-26.6	37.8	1.0	-63.4	-13.0	-50.4	
2.47	-67.8	H	3.0	-24.7	36.6	1.0	-60.3	-13.0	-47.3	
3.30	-69.9	H	3.0	-24.0	36.5	1.0	-59.5	-13.0	-46.5	
1.65	-68.1	V	3.0	-26.3	37.8	1.0	-63.2	-13.0	-50.2	
2.47	-67.2	V	3.0	-23.2	36.6	1.0	-58.8	-13.0	-45.8	
3.29	-69.8	V	3.0	-23.9	36.5	1.0	-59.5	-13.0	-46.5	
<b>Mid Channel (836.6MHz)</b>										
1.67	-67.8	H	3.0	-26.4	37.8	1.0	-63.2	-13.0	-50.2	
2.51	-68.6	H	3.0	-25.4	36.4	1.0	-60.8	-13.0	-47.8	
3.35	-69.6	H	3.0	-23.5	36.5	1.0	-59.0	-13.0	-46.0	
1.67	-67.8	V	3.0	-26.0	37.8	1.0	-62.8	-13.0	-49.8	
2.51	-68.5	V	3.0	-24.3	36.4	1.0	-59.7	-13.0	-46.7	
3.35	-70.2	V	3.0	-24.1	36.5	1.0	-59.6	-13.0	-46.6	
<b>High Channel (848.8MHz)</b>										
1.69	-68.2	H	3.0	-26.6	37.8	1.0	-63.5	-13.0	-50.5	
2.55	-68.4	H	3.0	-25.1	36.4	1.0	-60.5	-13.0	-47.5	
3.39	-70.1	H	3.0	-24.0	36.4	1.0	-59.5	-13.0	-46.5	
1.70	-66.6	V	3.0	-24.8	37.8	1.0	-61.6	-13.0	-48.6	
2.54	-68.2	V	3.0	-23.9	36.4	1.0	-59.3	-13.0	-46.3	
3.39	-69.9	V	3.0	-23.7	36.4	1.0	-59.2	-13.0	-46.2	

Rev. 03.19.15

**GPRS, 1900MHz BAND 2**

**High Frequency Substitution Measurement  
 UL Fremont Radiated Chamber**

Company:  
 Project #: 16U23816  
 Date: 12/07/16  
 Test Engineer: 39005  
 Configuration: EUT only  
 Mode: GPRS 1900MHz

**Test Equipment:**

Substitution: Horn T59 Substitution, and 8ft SMA Cable

Chamber	Pre-amplifier	Filter	Limit
3m Chamber G	3m Chamber G	Filter	EIRP

Frequency (GHz)	SA reading (dBm)	Ant. Pol. (H/V)	Distance	EIRP @ TX Ant End (dBm)	Preamp	Attenuator	EIRP	Limit	Delta	Notes
<b>Low Channel (1850.2MHz)</b>										
3.70	-65.9	H	3.0	-19.1	36.2	1.0	-54.4	-13.0	-41.4	
5.55	-65.6	H	3.0	-15.2	36.1	1.0	-50.4	-13.0	-37.4	
7.40	-66.5	H	3.0	-13.5	35.2	1.0	-47.7	-13.0	-34.7	
3.70	-65.4	V	3.0	-18.2	36.2	1.0	-53.5	-13.0	-40.5	
5.55	-65.3	V	3.0	-15.2	36.1	1.0	-50.3	-13.0	-37.3	
7.40	-65.9	V	3.0	-12.9	35.2	1.0	-47.2	-13.0	-34.2	
<b>Mid Channel (1880.0)</b>										
3.76	-65.9	H	3.0	-19.0	36.2	1.0	-54.2	-13.0	-41.2	
5.64	-64.2	H	3.0	-13.8	36.1	1.0	-48.9	-13.0	-35.9	
7.52	-66.5	H	3.0	-13.3	35.1	1.0	-47.5	-13.0	-34.5	
3.76	-65.8	V	3.0	-18.5	36.2	1.0	-53.7	-13.0	-40.7	
5.64	-63.6	V	3.0	-13.3	36.1	1.0	-48.4	-13.0	-35.4	
7.52	-66.1	V	3.0	-13.0	35.1	1.0	-47.1	-13.0	-34.1	
<b>High Channel (1909.8MHz)</b>										
3.82	-65.6	H	3.0	-18.6	36.1	1.0	-53.7	-13.0	-40.7	
5.73	-64.4	H	3.0	-13.7	36.1	1.0	-48.8	-13.0	-35.8	
7.64	-66.6	H	3.0	-13.3	35.0	1.0	-47.3	-13.0	-34.3	
3.82	-65.8	V	3.0	-18.3	36.1	1.0	-53.5	-13.0	-40.5	
5.73	-63.5	V	3.0	-13.1	36.1	1.0	-48.2	-13.0	-35.2	
7.64	-65.9	V	3.0	-12.7	35.0	1.0	-46.7	-13.0	-33.7	

Rev. 03.19.15

**EGPRS, 1900MHz BAND 2**

**High Frequency Substitution Measurement  
 UL Fremont Radiated Chamber**

Company:  
 Project #: 16U23816  
 Date: 12/07/16  
 Test Engineer: 39005  
 Configuration: EUT only  
 Mode: EGPRS 1900MHz

**Test Equipment:**  
 Substitution: Horn T59 Substitution, and 8ft SMA Cable

<b>Chamber</b>	<b>Pre-amplifier</b>	<b>Filter</b>	<b>Limit</b>
3m Chamber G	3m Chamber G	Filter	EIRP

Frequency (GHz)	SA reading (dBm)	Ant. Pol. (H/V)	Distance	EIRP @ TX Ant End (dBm)	Preamp	Attenuator	EIRP	Limit	Delta	Notes
<b>Low Channel (1850.2MHz)</b>										
3.70	-66.0	H	3.0	-19.2	36.2	1.0	-54.4	-13.0	-41.4	
5.55	-65.5	H	3.0	-15.2	36.1	1.0	-50.3	-13.0	-37.3	
7.40	-66.6	H	3.0	-13.5	35.2	1.0	-47.7	-13.0	-34.7	
3.70	-65.0	V	3.0	-17.8	36.2	1.0	-53.0	-13.0	-40.0	
5.55	-65.6	V	3.0	-15.5	36.1	1.0	-50.6	-13.0	-37.6	
7.40	-66.0	V	3.0	-13.0	35.2	1.0	-47.2	-13.0	-34.2	
<b>Mid Channel (1880.0)</b>										
3.76	-65.8	H	3.0	-18.9	36.2	1.0	-54.1	-13.0	-41.1	
5.64	-65.4	H	3.0	-14.9	36.1	1.0	-50.0	-13.0	-37.0	
7.52	-66.6	H	3.0	-13.4	35.1	1.0	-47.5	-13.0	-34.5	
3.76	-65.8	V	3.0	-18.5	36.2	1.0	-53.7	-13.0	-40.7	
5.64	-64.3	V	3.0	-14.0	36.1	1.0	-49.1	-13.0	-36.1	
7.52	-65.9	V	3.0	-12.8	35.1	1.0	-46.9	-13.0	-33.9	
<b>High Channel (1909.8MHz)</b>										
3.82	-65.5	H	3.0	-18.5	36.1	1.0	-53.7	-13.0	-40.7	
5.73	-64.5	H	3.0	-13.9	36.1	1.0	-48.9	-13.0	-35.9	
7.64	-66.4	H	3.0	-13.1	35.0	1.0	-47.1	-13.0	-34.1	
3.82	-66.2	V	3.0	-18.7	36.1	1.0	-53.9	-13.0	-40.9	
5.73	-64.3	V	3.0	-13.9	36.1	1.0	-48.9	-13.0	-35.9	
7.64	-66.0	V	3.0	-12.7	35.0	1.0	-46.8	-13.0	-33.8	

Rev. 03.19.15

## 11.2.2. CDMA2000

### CDMA2000 1xRTT, 850MHz BC0

#### High Frequency Substitution Measurement UL Fremont Radiated Chamber

Company:  
 Project #: 16U23814  
 Date: 01/12/17  
 Test Engineer: 29435  
 Configuration: EUT Only  
 Mode: 1xRTT 850MHz

Test Equipment:  
 Substitution: Horn T59 Substitution, and 8ft SMA Cable

Chamber	Pre-amplifier	Filter	Limit
3m Chamber D	3m Chamber D	Filter	EIRP

Frequency (GHz)	SA reading (dBm)	Ant. Pol. (H/V)	Distance	EIRP @ TX Ant End (dBm)	Preamp	Attenuator	EIRP	Limit	Delta	Notes
<b>Low Channel (824.7MHz)</b>										
1.65	-68.3	H	3.0	-26.5	35.0	1.0	-60.5	-13.0	-47.5	
2.48	-67.3	H	3.0	-23.2	33.9	1.0	-56.1	-13.0	-43.1	
3.30	-68.1	H	3.0	-21.3	33.2	1.0	-53.5	-13.0	-40.5	
1.65	-68.5	V	3.0	-26.5	35.0	1.0	-60.5	-13.0	-47.5	
2.47	-69.6	V	3.0	-25.3	33.9	1.0	-58.2	-13.0	-45.2	
3.30	-70.0	V	3.0	-23.1	33.2	1.0	-55.4	-13.0	-42.4	
<b>Mid Channel (836.52MHz)</b>										
1.67	-68.7	H	3.0	-26.9	35.0	1.0	-60.9	-13.0	-47.9	
2.51	-69.1	H	3.0	-24.8	33.7	1.0	-57.5	-13.0	-44.5	
3.35	-69.2	H	3.0	-22.2	33.3	1.0	-54.5	-13.0	-41.5	
1.67	-66.6	V	3.0	-24.6	35.0	1.0	-58.6	-13.0	-45.6	
2.51	-68.5	V	3.0	-24.0	33.7	1.0	-56.7	-13.0	-43.7	
3.34	-69.4	V	3.0	-22.4	33.3	1.0	-54.7	-13.0	-41.7	
<b>High Channel (848.31MHz)</b>										
1.70	-68.5	H	3.0	-26.6	35.0	1.0	-60.6	-13.0	-47.6	
2.54	-68.7	H	3.0	-24.3	33.7	1.0	-57.0	-13.0	-44.0	
3.40	-69.3	H	3.0	-22.2	33.3	1.0	-54.5	-13.0	-41.5	
1.70	-68.9	V	3.0	-26.8	35.0	1.0	-60.8	-13.0	-47.8	
2.54	-67.9	V	3.0	-23.3	33.7	1.0	-56.0	-13.0	-43.0	
3.39	-69.0	V	3.0	-21.9	33.3	1.0	-54.2	-13.0	-41.2	

Rev. 03.19.15

**CDMA2000 EVDO Rev A, 850MHz BC0**

**High Frequency Substitution Measurement  
 UL Fremont Radiated Chamber**

**Company:**  
**Project #:** 16U23816  
**Date:** 01/17/17  
**Test Engineer:** 37290  
**Configuration:** EUT only  
**Mode:** EVDO, Rev A 850MHz

**Test Equipment:**  
 Substitution: Horn T59 Substitution, and 8ft SMA Cable

<b>Chamber</b>	<b>Pre-amplifier</b>	<b>Filter</b>	<b>Limit</b>
3m Chamber D	3m Chamber D	Filter	EIRP

Frequency (GHz)	SA reading (dBm)	Ant. Pol. (H/V)	Distance	EIRP @ TX Ant End (dBm)	Preamp	Attenuator	EIRP	Limit	Delta	Notes
<b>Low Channel (824.7MHz)</b>										
1.65	-65.5	H	3.0	-23.8	35.0	1.0	-57.8	-13.0	-44.8	
2.47	-66.8	H	3.0	-22.6	33.9	1.0	-55.6	-13.0	-42.6	
3.30	-67.4	H	3.0	-20.7	33.2	1.0	-52.9	-13.0	-39.9	
1.65	-63.1	V	3.0	-21.1	35.0	1.0	-55.1	-13.0	-42.1	
2.48	-67.2	V	3.0	-22.8	33.9	1.0	-55.7	-13.0	-42.7	
3.30	-67.1	V	3.0	-20.2	33.2	1.0	-52.5	-13.0	-39.5	
<b>Mid Channel (836.52MHz)</b>										
1.67	-68.1	H	3.0	-26.3	35.0	1.0	-60.3	-13.0	-47.3	
2.51	-67.6	H	3.0	-23.3	33.7	1.0	-56.1	-13.0	-43.1	
3.35	-67.1	H	3.0	-20.2	33.3	1.0	-52.5	-13.0	-39.5	
1.67	-66.9	V	3.0	-24.9	35.0	1.0	-58.9	-13.0	-45.9	
2.51	-65.8	V	3.0	-21.3	33.7	1.0	-54.0	-13.0	-41.0	
3.35	-67.2	V	3.0	-20.2	33.3	1.0	-52.5	-13.0	-39.5	
<b>High Channel (848.31MHz)</b>										
1.70	-67.6	H	3.0	-25.7	35.0	1.0	-59.7	-13.0	-46.7	
2.55	-66.4	H	3.0	-22.0	33.7	1.0	-54.7	-13.0	-41.7	
3.40	-67.6	H	3.0	-20.5	33.3	1.0	-52.8	-13.0	-39.8	
1.70	-67.3	V	3.0	-25.2	35.0	1.0	-59.2	-13.0	-46.2	
2.54	-66.8	V	3.0	-22.2	33.7	1.0	-54.9	-13.0	-41.9	
3.40	-67.4	V	3.0	-20.3	33.3	1.0	-52.5	-13.0	-39.5	

Rev. 03.19.15

**CDMA2000 1xRTT, 1900MHz BC1**

**High Frequency Substitution Measurement  
 UL Fremont Radiated Chamber**

**Company:**  
**Project #:** 16U23816  
**Date:** 01/12/17  
**Test Engineer:** 29435  
**Configuration:** EUT only  
**Mode:** 1xRTT 1900MHz

**Test Equipment:**  
 Substitution: Horn T59 Substitution, and 8ft SMA Cable

<b>Chamber</b>	<b>Pre-amplifier</b>	<b>Filter</b>	<b>Limit</b>
3m Chamber D	3m Chamber D	Filter	EIRP

Frequency (GHz)	SA reading (dBm)	Ant. Pol. (H/V)	Distance	EIRP @ TX Ant End (dBm)	Preamp	Attenuator	EIRP	Limit	Delta	Notes
<b>Low Channel (1851.25MHz)</b>										
3.70	-68.3	H	3.0	-20.4	33.5	1.0	-52.9	-13.0	-39.9	
5.56	-68.9	H	3.0	-17.6	32.5	1.0	-49.1	-13.0	-36.1	
7.41	-71.3	H	3.0	-16.9	30.4	1.0	-46.3	-13.0	-33.3	
3.70	-67.0	V	3.0	-19.1	33.5	1.0	-51.6	-13.0	-38.6	
5.55	-69.7	V	3.0	-18.7	32.5	1.0	-50.1	-13.0	-37.1	
7.40	-70.7	V	3.0	-16.1	30.4	1.0	-45.5	-13.0	-32.5	
<b>Mid Channel (1880MHz)</b>										
3.76	-66.6	H	3.0	-18.5	33.5	1.0	-51.0	-13.0	-38.0	
5.64	-68.9	H	3.0	-17.4	32.4	1.0	-48.8	-13.0	-35.8	
7.52	-68.2	H	3.0	-13.7	30.3	1.0	-43.0	-13.0	-30.0	
3.76	-66.5	V	3.0	-18.4	33.5	1.0	-50.9	-13.0	-37.9	
5.64	-68.9	V	3.0	-17.7	32.4	1.0	-49.1	-13.0	-36.1	
7.52	-70.1	V	3.0	-15.4	30.3	1.0	-44.7	-13.0	-31.7	
<b>High Channel (1908.75MHz)</b>										
3.82	-67.9	H	3.0	-19.6	33.6	1.0	-52.2	-13.0	-39.2	
5.73	-69.4	H	3.0	-17.8	32.3	1.0	-49.1	-13.0	-36.1	
7.64	-71.0	H	3.0	-16.4	30.1	1.0	-45.5	-13.0	-32.5	
3.82	-67.7	V	3.0	-19.4	33.6	1.0	-52.0	-13.0	-39.0	
5.72	-69.1	V	3.0	-17.7	32.3	1.0	-49.0	-13.0	-36.0	
7.63	-70.1	V	3.0	-15.3	30.1	1.0	-44.4	-13.0	-31.4	

Rev. 03.19.15

**CDMA2000 EVDO Rev A, 1900MHz BC1**

**High Frequency Substitution Measurement  
 UL Fremont Radiated Chamber**

**Company:**  
**Project #:** 16U23816  
**Date:** 01/17/17  
**Test Engineer:** 37290  
**Configuration:** EUT only  
**Mode:** Rev 0/A 1900MHz

**Test Equipment:**  
 Substitution: Horn T59 Substitution, and 8ft SMA Cable

<b>Chamber</b>	<b>Pre-amplifier</b>	<b>Filter</b>	<b>Limit</b>
3m Chamber D	3m Chamber D	Filter	EIRP

Frequency (GHz)	SA reading (dBm)	Ant. Pol. (H/V)	Distance	EIRP @ TX Ant End (dBm)	Preamp	Attenuator	EIRP	Limit	Delta	Notes
<b>Low Channel (1851.25MHz)</b>										
3.70	-65.6	H	3.0	-17.7	33.5	1.0	-50.2	-13.0	-37.2	
5.55	-67.5	H	3.0	-16.2	32.5	1.0	-47.7	-13.0	-34.7	
7.40	-67.7	H	3.0	-13.3	30.4	1.0	-42.7	-13.0	-29.7	
3.70	-64.6	V	3.0	-16.7	33.5	1.0	-49.2	-13.0	-36.2	
5.55	-66.8	V	3.0	-15.8	32.5	1.0	-47.2	-13.0	-34.2	
7.40	-67.7	V	3.0	-13.1	30.4	1.0	-42.6	-13.0	-29.6	
<b>Mid Channel (1880MHz)</b>										
3.76	-65.2	H	3.0	-17.0	33.5	1.0	-49.6	-13.0	-36.6	
5.64	-62.0	H	3.0	-10.5	32.4	1.0	-41.9	-13.0	-28.9	
7.52	-67.1	H	3.0	-12.6	30.3	1.0	-41.9	-13.0	-28.9	
3.76	-65.2	V	3.0	-17.1	33.5	1.0	-49.7	-13.0	-36.7	
5.64	-67.3	V	3.0	-16.1	32.4	1.0	-47.5	-13.0	-34.5	
7.52	-67.7	V	3.0	-13.0	30.3	1.0	-42.3	-13.0	-29.3	
<b>High Channel (1908.75MHz)</b>										
3.82	-65.3	H	3.0	-17.0	33.6	1.0	-49.6	-13.0	-36.6	
5.72	-67.8	H	3.0	-16.2	32.3	1.0	-47.5	-13.0	-34.5	
7.63	-69.0	H	3.0	-14.4	30.1	1.0	-43.5	-13.0	-30.5	
3.82	-65.4	V	3.0	-17.1	33.6	1.0	-49.7	-13.0	-36.7	
5.73	-68.5	V	3.0	-17.1	32.3	1.0	-48.4	-13.0	-35.4	
7.63	-68.4	V	3.0	-13.6	30.1	1.0	-42.8	-13.0	-29.8	

Rev. 03.19.15

**CDMA2000 1xRTT, 800MHz BC10**

**High Frequency Substitution Measurement  
 UL Fremont Radiated Chamber**

**Company:**  
**Project #:** 16U23816  
**Date:** 01/12/17  
**Test Engineer:** 29435  
**Configuration:** EUT only  
**Mode:** 1xRTT 800MHz

**Test Equipment:**  
 Substitution: Horn T59 Substitution, and 8ft SMA Cable

<b>Chamber</b>	<b>Pre-amplifier</b>	<b>Filter</b>	<b>Limit</b>
3m Chamber D	3m Chamber D	Filter	EIRP

Frequency (GHz)	SA reading (dBm)	Ant. Pol. (H/V)	Distance	EIRP @ TX Ant End (dBm)	Preamp	Attenuator	EIRP	Limit	Delta	Notes
<b>Low Channel (817.25MHz)</b>										
1.63	-67.9	H	3.0	-26.2	35.0	1.0	-60.2	-13.0	-47.2	
2.45	-68.8	H	3.0	-24.8	34.1	1.0	-57.8	-13.0	-44.8	
3.27	-67.3	H	3.0	-20.6	33.2	1.0	-52.8	-13.0	-39.8	
1.63	-67.8	V	3.0	-25.8	35.0	1.0	-59.9	-13.0	-46.9	
2.45	-68.8	V	3.0	-24.5	34.1	1.0	-57.6	-13.0	-44.6	
3.27	-69.3	V	3.0	-22.5	33.2	1.0	-54.7	-13.0	-41.7	
<b>Mid Channel (820MHz)</b>										
1.64	-68.5	H	3.0	-26.7	35.0	1.0	-60.8	-13.0	-47.8	
2.46	-68.1	H	3.0	-24.0	34.0	1.0	-57.1	-13.0	-44.1	
3.28	-69.3	H	3.0	-22.6	33.2	1.0	-54.8	-13.0	-41.8	
1.64	-67.8	V	3.0	-25.8	35.0	1.0	-59.8	-13.0	-46.8	
2.46	-66.0	V	3.0	-21.7	34.0	1.0	-54.7	-13.0	-41.7	
3.28	-67.7	V	3.0	-20.9	33.2	1.0	-53.1	-13.0	-40.1	
<b>High Channel (822.75MHz)</b>										
1.65	-67.9	H	3.0	-26.1	35.0	1.0	-60.1	-13.0	-47.1	
2.47	-68.4	H	3.0	-24.3	34.0	1.0	-57.3	-13.0	-44.3	
3.29	-68.7	H	3.0	-22.0	33.2	1.0	-54.2	-13.0	-41.2	
1.65	-69.0	V	3.0	-27.0	35.0	1.0	-61.0	-13.0	-48.0	
2.47	-69.6	V	3.0	-25.3	33.9	1.0	-58.2	-13.0	-45.2	
3.29	-68.7	V	3.0	-21.9	33.2	1.0	-54.1	-13.0	-41.1	

Rev. 03.19.15

**CDMA2000 EVDO Rev A, 800MHz BC10**

**High Frequency Substitution Measurement  
 UL Fremont Radiated Chamber**

**Company:**  
**Project #:** 16U23816  
**Date:** 01/17/17  
**Test Engineer:** 37290  
**Configuration:** EUT only  
**Mode:** EVDO, Rev A, 800MHz

**Test Equipment:**  
 Substitution: Horn T59 Substitution, and 8ft SMA Cable

<b>Chamber</b>	<b>Pre-amplifier</b>	<b>Filter</b>	<b>Limit</b>
3m Chamber D	3m Chamber D	Filter	EIRP

Frequency (GHz)	SA reading (dBm)	Ant. Pol. (H/V)	Distance	EIRP @ TX Ant End (dBm)	Preamp	Attenuator	EIRP	Limit	Delta	Notes
<b>Low Channel (817.25MHz)</b>										
1.63	-66.5	H	3.0	-24.8	35.0	1.0	-58.8	-13.0	-45.8	
2.45	-67.7	H	3.0	-23.7	34.1	1.0	-56.8	-13.0	-43.8	
3.27	-67.6	H	3.0	-20.9	33.2	1.0	-53.1	-13.0	-40.1	
1.63	-64.3	V	3.0	-22.3	35.0	1.0	-56.4	-13.0	-43.4	
2.45	-68.0	V	3.0	-23.7	34.1	1.0	-56.8	-13.0	-43.8	
3.27	-66.8	V	3.0	-20.0	33.2	1.0	-52.2	-13.0	-39.2	
<b>Mid Channel (820MHz)</b>										
1.64	-67.4	H	3.0	-25.6	35.0	1.0	-59.6	-13.0	-46.6	
2.46	-67.7	H	3.0	-23.6	34.0	1.0	-56.6	-13.0	-43.6	
3.28	-67.9	H	3.0	-21.2	33.2	1.0	-53.4	-13.0	-40.4	
1.64	-66.6	V	3.0	-24.6	35.0	1.0	-58.6	-13.0	-45.6	
2.46	-66.0	V	3.0	-21.7	34.0	1.0	-54.7	-13.0	-41.7	
3.28	-66.3	V	3.0	-19.5	33.2	1.0	-51.7	-13.0	-38.7	
<b>High Channel (822.75MHz)</b>										
1.64	-66.0	H	3.0	-24.2	35.0	1.0	-58.3	-13.0	-45.3	
2.47	-67.4	H	3.0	-23.3	33.9	1.0	-56.2	-13.0	-43.2	
3.29	-65.9	H	3.0	-19.1	33.2	1.0	-51.3	-13.0	-38.3	
1.65	-67.1	V	3.0	-25.1	35.0	1.0	-59.1	-13.0	-46.1	
2.47	-67.2	V	3.0	-22.9	34.0	1.0	-55.8	-13.0	-42.8	
3.29	-66.9	V	3.0	-20.1	33.2	1.0	-52.3	-13.0	-39.3	

Rev. 03.19.15

### 11.2.3. UMTS

#### UMTS REL 99, 850MHz BAND 5

#### High Frequency Substitution Measurement UL Fremont Radiated Chamber

Company:  
 Project #: 16U23816  
 Date: 12/08/16  
 Test Engineer: 43574  
 Configuration: EUT only  
 Mode: REL 99, 850MHz

**Test Equipment:**

Substitution: Horn T59 Substitution, and 8ft SMA Cable

Chamber	Pre-amplifier	Filter	Limit
3m Chamber E	3m Chamber E	Filter	EIRP

Frequency (GHz)	SA reading (dBm)	Ant. Pol. (H/V)	Distance	EIRP @ TX Ant End (dBm)	Preamp	Attenuator	EIRP	Limit	Delta	Notes
<b>Low Channel (826.4MHz)</b>										
1.65	-65.9	H	3.0	-23.5	37.8	1.0	-60.3	-13.0	-47.3	
2.47	-65.2	H	3.0	-20.2	38.5	1.0	-57.6	-13.0	-44.6	
3.30	-69.0	H	3.0	-20.0	38.5	1.0	-57.5	-13.0	-44.5	
1.65	-66.3	V	3.0	-24.2	37.8	1.0	-61.0	-13.0	-48.0	
2.47	-64.9	V	3.0	-19.8	38.5	1.0	-57.2	-13.0	-44.2	
3.31	-69.1	V	3.0	-20.4	38.5	1.0	-57.9	-13.0	-44.9	
<b>Mid Channel (836.6MHz)</b>										
1.67	-65.4	H	3.0	-22.9	37.8	1.0	-59.7	-13.0	-46.7	
2.50	-64.7	H	3.0	-19.6	38.6	1.0	-57.1	-13.0	-44.1	
3.35	-69.0	H	3.0	-19.9	38.5	1.0	-57.4	-13.0	-44.4	
1.66	-65.8	V	3.0	-23.6	37.8	1.0	-60.4	-13.0	-47.4	
2.51	-65.2	V	3.0	-19.8	38.6	1.0	-57.4	-13.0	-44.4	
3.34	-68.2	V	3.0	-19.4	38.5	1.0	-56.8	-13.0	-43.8	
<b>High Channel (846.6MHz)</b>										
1.70	-65.6	H	3.0	-23.0	37.9	1.0	-59.8	-13.0	-46.8	
2.55	-65.3	H	3.0	-19.8	38.6	1.0	-57.4	-13.0	-44.4	
3.40	-67.4	H	3.0	-18.3	38.5	1.0	-55.8	-13.0	-42.8	
1.70	-66.5	V	3.0	-24.1	37.9	1.0	-61.0	-13.0	-48.0	
2.53	-64.4	V	3.0	-18.9	38.6	1.0	-56.4	-13.0	-43.4	
3.38	-66.7	V	3.0	-17.7	38.5	1.0	-55.2	-13.0	-42.2	

Rev. 03.19.15

**UMTS HSDPA, 850MHz BAND 5**

**High Frequency Substitution Measurement  
 UL Fremont Radiated Chamber**

**Company:**  
**Project #:** 16U23816  
**Date:** 12/8/2016  
**Test Engineer:** 43574  
**Configuration:** EUT only  
**Mode:** HSDPA 850MHz

**Test Equipment:**  
 Substitution: Horn T59 Substitution, and 8ft SMA Cable

<b>Chamber</b>	<b>Pre-amplifier</b>	<b>Filter</b>	<b>Limit</b>
3m Chamber E	3m Chamber E	Filter	EIRP

Frequency (GHz)	SA reading (dBm)	Ant. Pol. (H/V)	Distance	EIRP @ TX Ant End (dBm)	Preamp	Attenuator	EIRP	Limit	Delta	Notes
<b>Low Channel (826.4MHz)</b>										
1.65	-65.7	H	3.0	-23.3	37.8	1.0	-60.1	-13.0	-47.1	
2.49	-64.9	H	3.0	-19.8	38.5	1.0	-57.4	-13.0	-44.4	
3.30	-69.1	H	3.0	-20.1	38.5	1.0	-57.6	-13.0	-44.6	
1.64	-66.2	V	3.0	-24.1	37.8	1.0	-60.9	-13.0	-47.9	
2.48	-65.1	V	3.0	-19.9	38.5	1.0	-57.4	-13.0	-44.4	
3.31	-68.8	V	3.0	-20.1	38.5	1.0	-57.6	-13.0	-44.6	
<b>Mid Channel (836.6MHz)</b>										
1.68	-65.7	H	3.0	-23.1	37.9	1.0	-60.0	-13.0	-47.0	
2.51	-64.5	H	3.0	-19.3	38.6	1.0	-56.9	-13.0	-43.9	
3.34	-68.7	H	3.0	-19.7	38.5	1.0	-57.2	-13.0	-44.2	
1.68	-65.8	V	3.0	-23.5	37.9	1.0	-60.4	-13.0	-47.4	
2.50	-63.1	V	3.0	-17.7	38.6	1.0	-55.3	-13.0	-42.3	
3.34	-68.6	V	3.0	-19.8	38.5	1.0	-57.3	-13.0	-44.3	
<b>High Channel (846.6MHz)</b>										
1.70	-66.3	H	3.0	-23.7	37.9	1.0	-60.6	-13.0	-47.6	
2.53	-64.9	H	3.0	-19.6	38.6	1.0	-57.1	-13.0	-44.1	
3.38	-66.3	H	3.0	-17.2	38.5	1.0	-54.7	-13.0	-41.7	
1.69	-66.7	V	3.0	-24.4	37.9	1.0	-61.2	-13.0	-48.2	
2.54	-65.4	V	3.0	-19.9	38.6	1.0	-57.5	-13.0	-44.5	
3.38	-67.7	V	3.0	-18.8	38.5	1.0	-56.3	-13.0	-43.3	

Rev. 03.19.15

**UMTS REL 99, 1900MHz BAND 2**

**High Frequency Substitution Measurement  
 UL Fremont Radiated Chamber**

**Company:**  
**Project #:** 16U23816  
**Date:** 12/07/16  
**Test Engineer:** 39005  
**Configuration:** EUT only  
**Mode:** REL 99, 1900MHz

**Test Equipment:**  
 Substitution: Horn T59 Substitution, and 8ft SMA Cable

<b>Chamber</b>	<b>Pre-amplifier</b>	<b>Filter</b>	<b>Limit</b>
3m Chamber G	3m Chamber G	Filter	EIRP

Frequency (GHz)	SA reading (dBm)	Ant. Pol. (H/V)	Distance	EIRP @ TX Ant End (dBm)	Preamp	Attenuator	EIRP	Limit	Delta	Notes
<b>Low Channel (1852.4MHz)</b>										
3.70	-65.5	H	3.0	-18.8	36.2	1.0	-54.0	-13.0	-41.0	
5.56	-67.0	H	3.0	-16.7	36.1	1.0	-51.8	-13.0	-38.8	
7.41	-66.2	H	3.0	-13.2	35.2	1.0	-47.4	-13.0	-34.4	
3.70	-65.4	V	3.0	-18.3	36.2	1.0	-53.5	-13.0	-40.5	
5.56	-65.4	V	3.0	-15.3	36.1	1.0	-50.4	-13.0	-37.4	
7.41	-66.8	V	3.0	-13.8	35.2	1.0	-48.0	-13.0	-35.0	
<b>Mid Channel (1880MHz)</b>										
3.76	-65.2	H	3.0	-18.3	36.2	1.0	-53.5	-13.0	-40.5	
5.64	-65.4	H	3.0	-14.9	36.1	1.0	-50.0	-13.0	-37.0	
7.52	-67.0	H	3.0	-13.8	35.1	1.0	-47.9	-13.0	-34.9	
3.76	-65.5	V	3.0	-18.2	36.2	1.0	-53.4	-13.0	-40.4	
5.64	-66.4	V	3.0	-16.1	36.1	1.0	-51.2	-13.0	-38.2	
7.52	-66.7	V	3.0	-13.6	35.1	1.0	-47.7	-13.0	-34.7	
<b>High Channel (1907.6MHz)</b>										
3.82	-65.8	H	3.0	-18.8	36.1	1.0	-53.9	-13.0	-40.9	
5.72	-66.5	H	3.0	-15.8	36.1	1.0	-50.9	-13.0	-37.9	
7.63	-66.6	H	3.0	-13.3	35.0	1.0	-47.4	-13.0	-34.4	
3.82	-65.7	V	3.0	-18.2	36.1	1.0	-53.3	-13.0	-40.3	
5.72	-66.2	V	3.0	-15.8	36.1	1.0	-50.9	-13.0	-37.9	
7.63	-66.5	V	3.0	-13.3	35.0	1.0	-47.4	-13.0	-34.4	

Rev. 03.19.15

**UMTS HSDPA, 1900MHz BAND 2**

**High Frequency Substitution Measurement  
 UL Fremont Radiated Chamber**

**Company:**  
**Project #:** 16U23816  
**Date:** 12/07/16  
**Test Engineer:** 39005  
**Configuration:** EUT only  
**Mode:** HSDPA 1900MHz

**Test Equipment:**  
 Substitution: Horn T59 Substitution, and 8ft SMA Cable

<b>Chamber</b>	<b>Pre-amplifier</b>	<b>Filter</b>	<b>Limit</b>
3m Chamber G	3m Chamber G	Filter	EIRP

Frequency (GHz)	SA reading (dBm)	Ant. Pol. (H/V)	Distance	EIRP @ TX Ant End (dBm)	Preamp	Attenuator	EIRP	Limit	Delta	Notes
<b>Low Channel (1852.4MHz)</b>										
3.70	-65.6	H	3.0	-18.9	36.2	1.0	-54.1	-13.0	-41.1	
5.56	-66.8	H	3.0	-16.5	36.1	1.0	-51.6	-13.0	-38.6	
7.41	-66.5	H	3.0	-13.4	35.2	1.0	-47.6	-13.0	-34.6	
3.70	-65.6	V	3.0	-18.5	36.2	1.0	-53.7	-13.0	-40.7	
5.56	-65.6	V	3.0	-15.5	36.1	1.0	-50.6	-13.0	-37.6	
7.41	-66.8	V	3.0	-13.7	35.2	1.0	-48.0	-13.0	-35.0	
<b>Mid Channel (1880MHz)</b>										
3.76	-65.5	H	3.0	-18.6	36.2	1.0	-53.8	-13.0	-40.8	
5.64	-65.7	H	3.0	-15.2	36.1	1.0	-50.3	-13.0	-37.3	
7.52	-66.5	H	3.0	-13.3	35.1	1.0	-47.5	-13.0	-34.5	
3.76	-65.6	V	3.0	-18.3	36.2	1.0	-53.5	-13.0	-40.5	
5.64	-66.5	V	3.0	-16.2	36.1	1.0	-51.3	-13.0	-38.3	
7.52	-66.7	V	3.0	-13.6	35.1	1.0	-47.7	-13.0	-34.7	
<b>High Channel (1907.6MHz)</b>										
3.82	-65.8	H	3.0	-18.8	36.1	1.0	-53.9	-13.0	-40.9	
5.72	-66.5	H	3.0	-15.9	36.1	1.0	-51.0	-13.0	-38.0	
7.63	-66.8	H	3.0	-13.5	35.0	1.0	-47.5	-13.0	-34.5	
3.82	-65.8	V	3.0	-18.3	36.1	1.0	-53.5	-13.0	-40.5	
5.72	-66.4	V	3.0	-16.0	36.1	1.0	-51.1	-13.0	-38.1	
7.63	-66.6	V	3.0	-13.4	35.0	1.0	-47.4	-13.0	-34.4	

Rev. 03.19.15

**UMTS REL 99, 1700MHz BAND 4**

**High Frequency Substitution Measurement  
 UL Fremont Radiated Chamber**

**Company:**  
**Project #:** 16U23816  
**Date:** 12/07/16  
**Test Engineer:** 39005  
**Configuration:** EUT only  
**Mode:** REL 99, 1700MHz

**Test Equipment:**  
 Substitution: Horn T59 Substitution, and 8ft SMA Cable

<b>Chamber</b>	<b>Pre-amplifier</b>	<b>Filter</b>	<b>Limit</b>
3m Chamber G	3m Chamber G	Filter	EIRP

Frequency (GHz)	SA reading (dBm)	Ant. Pol. (H/V)	Distance	EIRP @ TX Ant End (dBm)	Preamp	Attenuator	EIRP	Limit	Delta	Notes
<b>Low Channel (1712.4MHz)</b>										
3.42	-65.2	H	3.0	-19.0	36.4	1.0	-54.5	-13.0	-41.5	
5.14	-65.3	H	3.0	-15.7	36.3	1.0	-51.0	-13.0	-38.0	
6.85	-65.0	H	3.0	-12.5	35.6	1.0	-47.1	-13.0	-34.1	
3.42	-65.3	V	3.0	-19.0	36.4	1.0	-54.5	-13.0	-41.5	
5.14	-64.9	V	3.0	-15.4	36.3	1.0	-50.7	-13.0	-37.7	
6.85	-65.3	V	3.0	-12.9	35.6	1.0	-47.5	-13.0	-34.5	
<b>Mid Channel (1732.6MHz)</b>										
3.47	-65.2	H	3.0	-19.0	36.4	1.0	-54.3	-13.0	-41.3	
5.20	-65.3	H	3.0	-15.6	36.3	1.0	-50.8	-13.0	-37.8	
6.93	-65.3	H	3.0	-12.7	35.5	1.0	-47.3	-13.0	-34.3	
3.47	-65.2	V	3.0	-18.8	36.4	1.0	-54.2	-13.0	-41.2	
5.20	-65.4	V	3.0	-15.9	36.3	1.0	-51.2	-13.0	-38.2	
6.93	-66.3	V	3.0	-13.8	35.5	1.0	-48.3	-13.0	-35.3	
<b>High Channel (1752.6MHz)</b>										
3.51	-65.3	H	3.0	-19.0	36.4	1.0	-54.3	-13.0	-41.3	
5.26	-65.3	H	3.0	-15.5	36.3	1.0	-50.7	-13.0	-37.7	
7.01	-65.9	H	3.0	-13.2	35.5	1.0	-47.7	-13.0	-34.7	
3.51	-65.3	V	3.0	-18.8	36.4	1.0	-54.1	-13.0	-41.1	
5.26	-64.9	V	3.0	-15.3	36.3	1.0	-50.5	-13.0	-37.5	
7.01	-65.1	V	3.0	-12.5	35.5	1.0	-47.0	-13.0	-34.0	

Rev. 03.19.15

**UMTS HSDPA, 1700MHz BAND 4**

**High Frequency Substitution Measurement  
 UL Fremont Radiated Chamber**

**Company:**  
**Project #:** 16U23816  
**Date:** 12/07/16  
**Test Engineer:** 39005  
**Configuration:** EUT only  
**Mode:** HSDPA 1700MHz

**Test Equipment:**  
 Substitution: Horn T59 Substitution, and 8ft SMA Cable

<b>Chamber</b>	<b>Pre-amplifier</b>	<b>Filter</b>	<b>Limit</b>
3m Chamber G	3m Chamber G	Filter	EIRP

Frequency (GHz)	SA reading (dBm)	Ant. Pol. (H/V)	Distance	EIRP @ TX Ant End (dBm)	Preamp	Attenuator	EIRP	Limit	Delta	Notes
<b>Low Channel (1712.4MHz)</b>										
3.42	-65.5	H	3.0	-19.3	36.4	1.0	-54.7	-13.0	-41.7	
5.14	-65.7	H	3.0	-16.1	36.3	1.0	-51.4	-13.0	-38.4	
6.85	-65.1	H	3.0	-12.7	35.6	1.0	-47.2	-13.0	-34.2	
3.42	-65.2	V	3.0	-18.9	36.4	1.0	-54.3	-13.0	-41.3	
5.14	-65.0	V	3.0	-15.5	36.3	1.0	-50.8	-13.0	-37.8	
6.85	-65.3	V	3.0	-12.9	35.6	1.0	-47.5	-13.0	-34.5	
<b>Mid Channel (1732.6MHz)</b>										
3.47	-65.4	H	3.0	-19.1	36.4	1.0	-54.5	-13.0	-41.5	
5.20	-65.4	H	3.0	-15.7	36.3	1.0	-50.9	-13.0	-37.9	
6.93	-65.4	H	3.0	-12.8	35.5	1.0	-47.3	-13.0	-34.3	
3.47	-65.4	V	3.0	-18.9	36.4	1.0	-54.3	-13.0	-41.3	
5.20	-65.5	V	3.0	-16.0	36.3	1.0	-51.2	-13.0	-38.2	
6.93	-66.0	V	3.0	-13.5	35.5	1.0	-48.0	-13.0	-35.0	
<b>High Channel (1752.6MHz)</b>										
3.51	-65.3	H	3.0	-19.0	36.4	1.0	-54.3	-13.0	-41.3	
5.26	-65.4	H	3.0	-15.6	36.3	1.0	-50.8	-13.0	-37.8	
7.01	-65.3	H	3.0	-12.6	35.5	1.0	-47.1	-13.0	-34.1	
3.51	-65.7	V	3.0	-19.1	36.4	1.0	-54.5	-13.0	-41.5	
5.26	-65.3	V	3.0	-15.7	36.3	1.0	-51.0	-13.0	-38.0	
7.01	-65.3	V	3.0	-12.6	35.5	1.0	-47.1	-13.0	-34.1	

Rev. 03.19.15