



CERTIFICATION TEST REPORT

Report Number. : 16U23815-E2V2

Applicant : APPLE, INC.
1 INFINITE LOOP
CUPERTINO, CA 95014, U.S.A.

Model : A1670

FCC ID : BCGA1670

IC : 579C-A1670

EUT Description : TABLET DEVICE

Test Standard(s) : FCC 47 CFR PART 15 SUBPART C
INDUSTRY CANADA RSS - 247 ISSUE 1

Date Of Issue:
February 27, 2017

Prepared by:
UL Verification Services Inc.
47173 Benicia Street
Fremont, CA 94538, U.S.A.
TEL: (510) 771-1000
FAX: (510) 661-0888



Revision History

<u>Rev.</u>	<u>Issue Date</u>	<u>Revisions</u>	<u>Revised By</u>
V1	02/15/2017	Initial Review	Mengistu Mekuria
V2	02/27/2017	Address TCB's Questions	Chin Pang

TABLE OF CONTENTS

1. ATTESTATION OF TEST RESULTS	6
2. TEST METHODOLOGY	7
3. FACILITIES AND ACCREDITATION	7
4. CALIBRATION AND UNCERTAINTY	8
4.1. <i>MEASURING INSTRUMENT CALIBRATION</i>	<i>8</i>
4.2. <i>SAMPLE CALCULATION</i>	<i>8</i>
4.3. <i>MEASUREMENT UNCERTAINTY.....</i>	<i>8</i>
5. EQUIPMENT UNDER TEST.....	9
5.1. <i>DESCRIPTION OF EUT.....</i>	<i>9</i>
5.2. <i>MAXIMUM OUTPUT POWER.....</i>	<i>9</i>
5.3. <i>DESCRIPTION OF AVAILABLE ANTENNAS.....</i>	<i>9</i>
5.4. <i>SOFTWARE AND FIRMWARE.....</i>	<i>9</i>
5.5. <i>WORST-CASE CONFIGURATION AND MODE.....</i>	<i>10</i>
5.6. <i>DESCRIPTION OF TEST SETUP.....</i>	<i>11</i>
6. TEST AND MEASUREMENT EQUIPMENT	17
7. MEASUREMENT METHODS	18
8. ANTENNA PORT TEST RESULTS.....	19
8.1. <i>ON TIME AND DUTY CYCLE.....</i>	<i>19</i>
8.1.1. <i>HIGH POWER MODE.....</i>	<i>20</i>
8.1.2. <i>LOW POWER MODE</i>	<i>21</i>
8.2. <i>HIGH POWER BASIC DATA RATE GFSK MODULATION.....</i>	<i>22</i>
8.2.1. <i>20 dB AND 99% BANDWIDTH</i>	<i>22</i>
8.2.2. <i>HOPPING FREQUENCY SEPARATION</i>	<i>25</i>
8.2.3. <i>NUMBER OF HOPPING CHANNELS.....</i>	<i>26</i>
8.2.4. <i>AVERAGE TIME OF OCCUPANCY</i>	<i>29</i>
8.2.5. <i>OUTPUT POWER</i>	<i>33</i>
8.2.6. <i>AVERAGE POWER.....</i>	<i>34</i>
8.2.7. <i>CONDUCTED BANDEDGE AND SPURIOUS EMISSIONS.....</i>	<i>35</i>
8.3. <i>HIGH POWER ENHANCED DATA RATE DQPSK MODULATION.....</i>	<i>39</i>
8.3.1. <i>OUTPUT POWER</i>	<i>39</i>
8.3.2. <i>AVERAGE POWER.....</i>	<i>40</i>
8.4. <i>HIGH POWER ENHANCED DATA RATE 8PSK MODULATION</i>	<i>41</i>
8.4.1. <i>20 dB AND 99% BANDWIDTH</i>	<i>41</i>
8.4.2. <i>HOPPING FREQUENCY SEPARATION</i>	<i>44</i>
8.4.3. <i>NUMBER OF HOPPING CHANNELS.....</i>	<i>45</i>
8.4.4. <i>AVERAGE TIME OF OCCUPANCY</i>	<i>48</i>

8.4.5.	OUTPUT POWER	52
8.4.6.	AVERAGE POWER	53
8.4.7.	CONDUCTED BANDEDGE AND SPURIOUS EMISSIONS.....	54
8.5.	<i>LOW POWER BASIC DATA RATE GFSK MODULATION</i>	58
8.5.1.	20 dB AND 99% BANDWIDTH	58
8.5.2.	HOPPING FREQUENCY SEPARATION	61
8.5.3.	NUMBER OF HOPPING CHANNELS.....	62
8.5.4.	AVERAGE TIME OF OCCUPANCY	65
8.5.5.	OUTPUT POWER	69
8.5.6.	AVERAGE POWER.....	70
8.5.7.	CONDUCTED BANDEDGE AND SPURIOUS EMISSIONS.....	71
8.6.	<i>LOW POWER ENHANCED DATA RATE DQPSK MODULATION</i>	75
8.6.1.	OUTPUT POWER	75
8.6.2.	AVERAGE POWER.....	76
8.7.	<i>LOW POWER ENHANCED DATA RATE 8PSK MODULATION</i>	77
8.7.1.	20 dB AND 99% BANDWIDTH	77
8.7.2.	HOPPING FREQUENCY SEPARATION	80
8.7.3.	NUMBER OF HOPPING CHANNELS.....	81
8.7.4.	AVERAGE TIME OF OCCUPANCY	84
8.7.5.	OUTPUT POWER	88
8.7.6.	AVERAGE POWER.....	89
8.7.7.	CONDUCTED BANDEDGE AND SPURIOUS EMISSIONS.....	90
9.	RADIATED TEST RESULTS.....	94
9.1.	<i>LIMITS AND PROCEDURE</i>	94
9.2.	<i>HIGH POWER BASIC DATA RATE GFSK MODULATION</i>	95
9.2.1.	RESTRICTED BANDEDGE (LOW CHANNEL).....	95
9.2.2.	AUTHORIZED BANDEDGE (HIGH CHANNEL).....	97
9.2.3.	HARMONICS AND SPURIOUS EMISSIONS	99
9.3.	<i>HIGH POWER ENHANCED DATA RATE 8PSK MODULATION</i>	105
9.3.1.	RESTRICTED BANDEDGE (LOW CHANNEL).....	105
9.3.2.	AUTHORIZED BANDEDGE (HIGH CHANNEL).....	107
9.3.3.	HARMONICS AND SPURIOUS EMISSIONS	109
9.4.	<i>LOW POWER BASIC DATA RATE GFSK MODULATION</i>	115
9.4.1.	RESTRICTED BANDEDGE (LOW CHANNEL).....	115
9.4.2.	AUTHORIZED BANDEDGE (HIGH CHANNEL).....	117
9.4.3.	HARMONICS AND SPURIOUS EMISSIONS	119
9.5.	<i>LOW POWER ENHANCED DATA RATE 8PSK MODULATION</i>	125
9.5.1.	RESTRICTED BANDEDGE (LOW CHANNEL).....	125
9.5.2.	AUTHORIZED BANDEDGE (HIGH CHANNEL).....	127
9.5.3.	HARMONICS AND SPURIOUS EMISSIONS	129
9.6.	<i>WORST-CASE CO-LOCATION</i>	135
9.7.	<i>WORST-CASE BELOW 1 GHz</i>	137
9.8.	<i>WORST-CASE ABOVE 18 GHz</i>	139
10.	AC POWER LINE CONDUCTED EMISSIONS	141
10.1.	<i>EUT POWERED BY AC/DC ADAPTER VIA USB CABLE</i>	142

10.2.	EUT POWERED BY HOST PC VIA USB CABLE.....	144
11.	SETUP PHOTOS	146

1. ATTESTATION OF TEST RESULTS

COMPANY NAME: APPLE
1 INFINITE LOOP
CUPERTINO, CA 95014, U.S.A.

EUT DESCRIPTION: TABLET DEVICE

MODEL: A1670

SERIAL NUMBER: CONDUCTED (DLXST005HPK5), RADIATED (DLXST008HPK5)

DATE TESTED: NOVEMBER 23, 2016 – JANUARY 20, 2017

APPLICABLE STANDARDS	
STANDARD	TEST RESULTS
CFR 47 Part 15 Subpart C	Pass
INDUSTRY CANADA RSS-247 Issue 1	Pass
INDUSTRY CANADA RSS-GEN Issue 4	Pass

UL Verification Services Inc. tested the above equipment in accordance with the requirements set forth in the above standards. All indications of Pass/Fail in this report are opinions expressed by UL Verification Services Inc. based on interpretations and/or observations of test results. Measurement Uncertainties were not taken into account and are published for informational purposes only. The test results show that the equipment tested is capable of demonstrating compliance with the requirements as documented in this report.

Note: The results documented in this report apply only to the tested sample, under the conditions and modes of operation as described herein. This document may not be altered or revised in any way unless done so by UL Verification Services Inc. and all revisions are duly noted in the revisions section. Any alteration of this document not carried out by UL Verification Services Inc. will constitute fraud and shall nullify the document. This report must not be used by the client to claim product certification, approval, or endorsement by NVLAP, NIST, any agency of the Federal Government, or any agency of any government.

Approved & Released For
UL Verification Services Inc. By:

Prepared By:

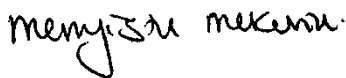

MENGISTU MEKURIA
SENIOR ENGINEER
UL VERIFICATION SERVICES INC.

CHRIS XIONG
TEST ENGINEER
UL VERIFICATION SERVICES INC.

2. TEST METHODOLOGY

The tests documented in this report were performed in accordance with FCC CFR 47 Part 2, FCC CFR 47 Part 15, ANSI C63.10-2013, RSS-GEN Issue 4, and RSS-247 Issue 1.

3. FACILITIES AND ACCREDITATION

The test sites and measurement facilities used to collect data are located at 47173 and 47266 Benicia Street, Fremont, California, USA. Line conducted emissions are measured only at the 47173 address. The following table identifies which facilities were utilized for radiated emission measurements documented in this report. Specific facilities are also identified in the test results sections.

47173 Benicia Street		47266 Benicia Street	
<input type="checkbox"/>	Chamber A (IC:2324B-1)	<input type="checkbox"/>	Chamber D (IC:2324B-4)
<input type="checkbox"/>	Chamber B (IC:2324B-2)	<input checked="" type="checkbox"/>	Chamber E (IC:2324B-5)
<input checked="" type="checkbox"/>	Chamber C (IC:2324B-3)	<input checked="" type="checkbox"/>	Chamber F (IC:2324B-6)
		<input type="checkbox"/>	Chamber G (IC:2324B-7)
		<input checked="" type="checkbox"/>	Chamber H (IC:2324B-8)

The above test sites and facilities are covered under FCC Test Firm Registration # 208313.

UL Verification Services Inc. is accredited by NVLAP, Laboratory Code 200065-0. The full scope of accreditation can be viewed at <http://ts.nist.gov/standards/scopes/2000650.htm>.

4. CALIBRATION AND UNCERTAINTY

4.1. MEASURING INSTRUMENT CALIBRATION

The measuring equipment utilized to perform the tests documented in this report has been calibrated in accordance with the manufacturer's recommendations, and is traceable to recognized national standards.

4.2. SAMPLE CALCULATION

Where relevant, the following sample calculation is provided:

$$\begin{aligned} \text{Field Strength (dBuV/m)} &= \text{Measured Voltage (dBuV)} + \text{Antenna Factor (dB/m)} + \\ &\text{Cable Loss (dB)} - \text{Preamp Gain (dB)} \\ 36.5 \text{ dBuV} + 18.7 \text{ dB/m} + 0.6 \text{ dB} - 26.9 \text{ dB} &= 28.9 \text{ dBuV/m} \end{aligned}$$

4.3. MEASUREMENT UNCERTAINTY

Where relevant, the following measurement uncertainty levels have been estimated for tests performed on the apparatus:

Parameter	Uncertainty
Worst Case Conducted Disturbance, 9KHz to 0.15 MHz	3.84 dB
Worst Case Conducted Disturbance, 0.15 to 30 MHz	3.65 dB
Worst Case Radiated Disturbance, 9KHz to 30 MHz	3.15 dB
Worst Case Radiated Disturbance, 30 to 1000 MHz	5.36 dB
Worst Case Radiated Disturbance, 1000 to 18000 MHz	4.32 dB
Worst Case Radiated Disturbance, 18000 to 26000 MHz	4.45 dB
Worst Case Radiated Disturbance, 26000 to 40000 MHz	5.24 dB

Uncertainty figures are valid to a confidence level of 95%.

5. EQUIPMENT UNDER TEST

5.1. DESCRIPTION OF EUT

The EUT is a tablet with multimedia functions (music, application support, and video), IEEE 802.11a/b/g/n/ac radio, and Bluetooth radio. The rechargeable battery is not user accessible.

5.2. MAXIMUM OUTPUT POWER

The transmitter has a maximum peak conducted output power as follows:

Frequency Range (MHz)	Mode	Output Power (dBm)	Output Power (mW)
2402 - 2480	Basic GFSK	17.20	52.48
2402 - 2480	DQPSK	19.20	83.18
2402 - 2480	Enhanced 8PSK	19.25	84.14

5.3. DESCRIPTION OF AVAILABLE ANTENNAS

Frequency Band (GHz)	Antenna Gain (dBi)
2.4	-0.48

5.4. SOFTWARE AND FIRMWARE

The firmware installed in the EUT during testing was 14E232.

5.5. WORST-CASE CONFIGURATION AND MODE

For below 1G, 18-26GHz radiated emission, and power line conducted emissions were performed with the EUT set to transmit at the channel with highest output power as worst-case scenario.

The fundamental of the EUT was investigated in three orthogonal orientations X/Y/Z, it was determined that Y-Landscape orientation was worst-case orientation. Therefore, all final radiated testing was performed with the EUT in Y-Landscape orientation.

Worst-case data rates were:

GFSK mode: DH5
8PSK mode: 3-DH5

DQPSK mode has been verified to have the lowest power.

There are two vendors of the WiFi/Bluetooth radio modules: variant 1 and variant 2. The WiFi/Bluetooth radio modules have the same mechanical outline (e.g., the same package dimension and pin-out layout), use the same on-board antenna matching circuit, have an identical antenna structure, and are built and tested to conform to the same specifications and to operate within the same tolerances.

Baseline testing was performed on the two variants to determine the worst case on all conducted power and radiated emissions.

5.6. DESCRIPTION OF TEST SETUP

SUPPORT EQUIPMENT

Support Equipment List				
Description	Manufacturer	Model	Serial Number	FCC ID
Laptop	Apple	A1286	7313700NAGW	N/A
Laptop AC/DC adapter	Apple	A1343	C062172045DDJ94A6	N/A
Earphone	Apple	NA	NA	N/A
EUT AC/DC adapter	Apple	A1357	W010A051	N/A

I/O CABLES (CONDUCTED TEST)

I/O Cable List						
Cable No	Port	# of identical ports	Connector Type	Cable Type	Cable Length (m)	Remarks
1	Antenna	1	SMA	Un-Shielded	0.2	To spectrum Analyzer
2	USB	1	USB	Shielded	1	N/A
3	AC	1	AC	Un-shielded	2	N/A

I/O CABLES (RADIATED ABOVE 1 GHZ)

I/O Cable List						
Cable No	Port	# of identical ports	Connector Type	Cable Type	Cable Length (m)	Remarks
None Used						

I/O CABLES (RADIATED BELOW 1 GHZ AND AC LINE CONDUCTED: AC/DC ADAPTER CONFIGURATION)

I/O Cable List						
Cable No	Port	# of identical	Connector Type	Cable Type	Cable Length (m)	Remarks
1	Earphone Jack	1	3.5mm Audio	Shielded	0.9	N/A
2	USB	1	USB	shielded	1	N/A

I/O CABLES (AC LINE CONDUCTED: LAPTOP CONFIGUARTION)

I/O Cable List						
Cable No	Port	# of identical	Connector Type	Cable Type	Cable Length (m)	Remarks
1	Earphone Jack	1	3.5mm Audio	Shielded	0.9	N/A
2	USB	1	USB	Shielded	1	N/A
3	AC	1	AC	Un-shielded	2	N/A

TEST SETUP - CONDUCTED TESTS

The EUT was connected to a host Laptop via USB cable adapter and spectrum analyzer to antenna port. Test software exercised the EUT.

SETUP DIAGRAM

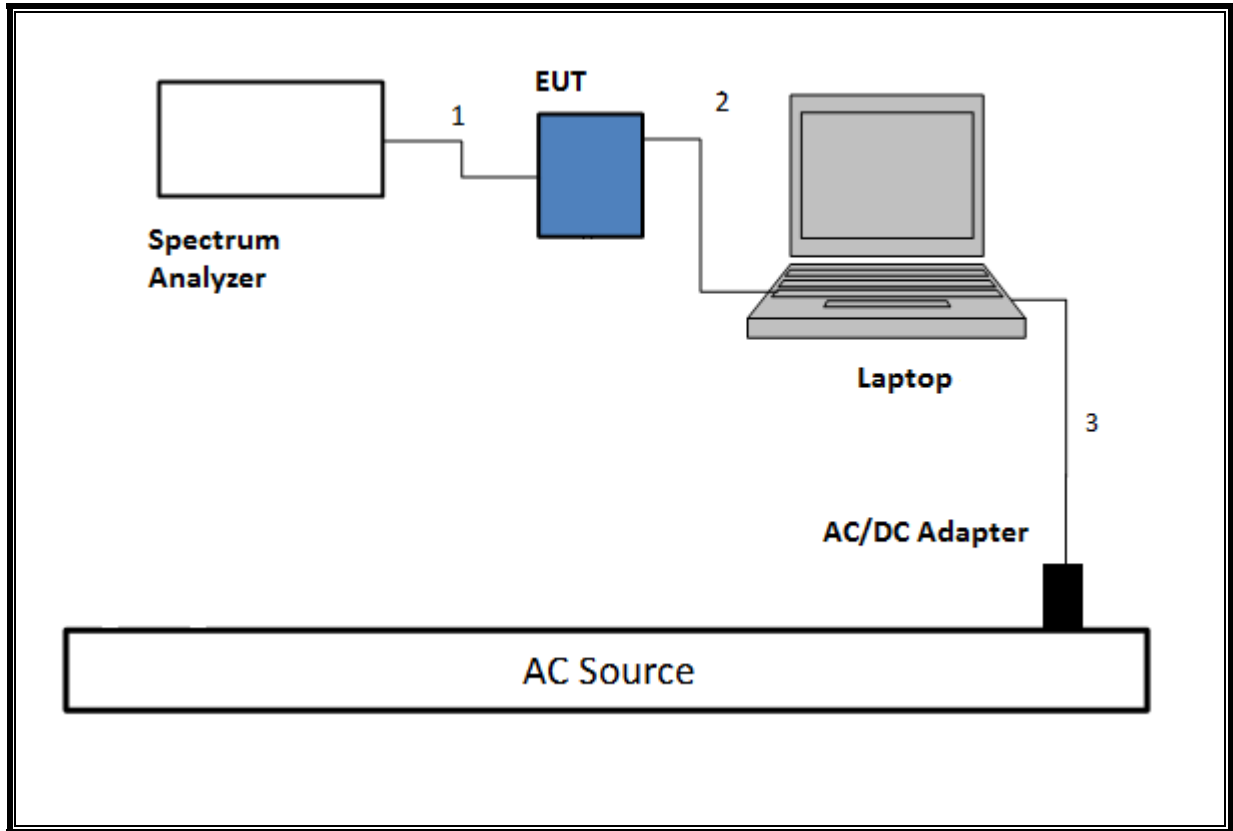

TEST SETUP- RADIATED-ABOVE 1 GHZ

The EUT was powered by battery. Test software exercised the EUT.

SETUP DIAGRAM

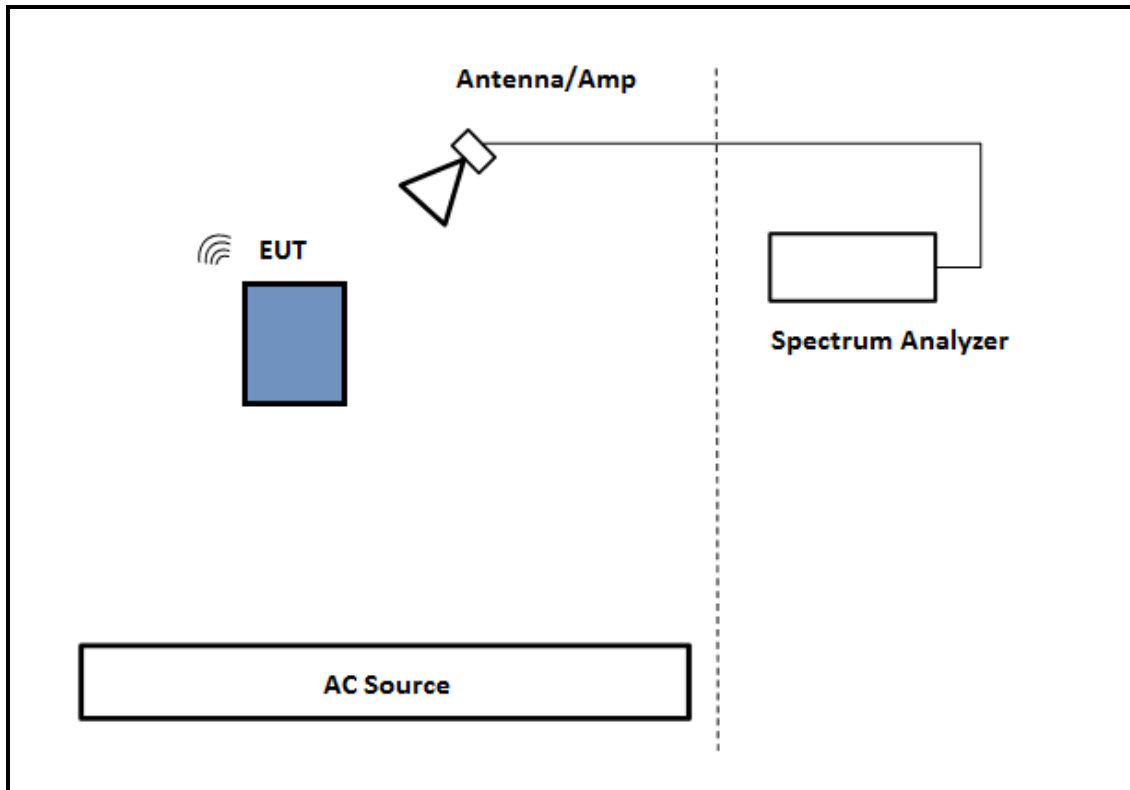

TEST SETUP- BELOW 1GHz

The EUT was powered by AC/DC adapter and connected with earphone. Test software exercised the EUT.

SETUP DIAGRAM

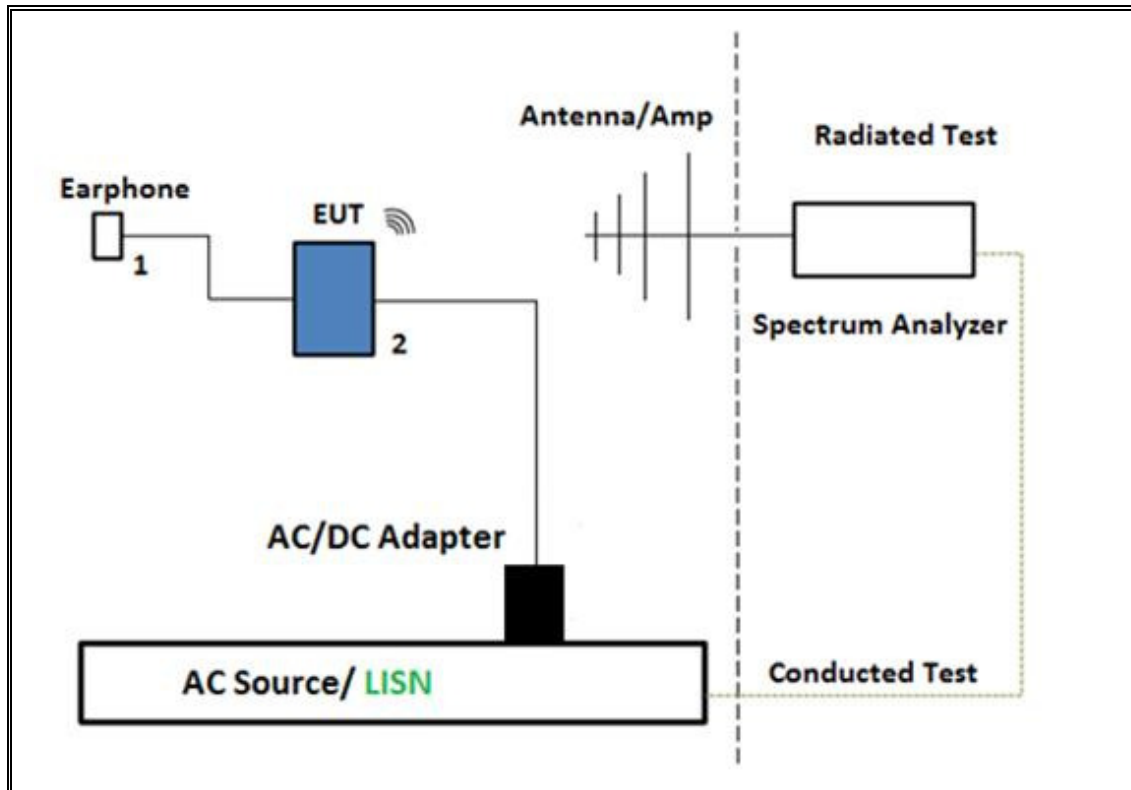

TEST SETUP- AC LINE CONDUCTED: AC/DC ADAPTER CONFIGURATION

The EUT was tested with earphone connected and powered by AC/DC adapter via USB cable. Test software exercised the EUT.

SETUP DIAGRAM

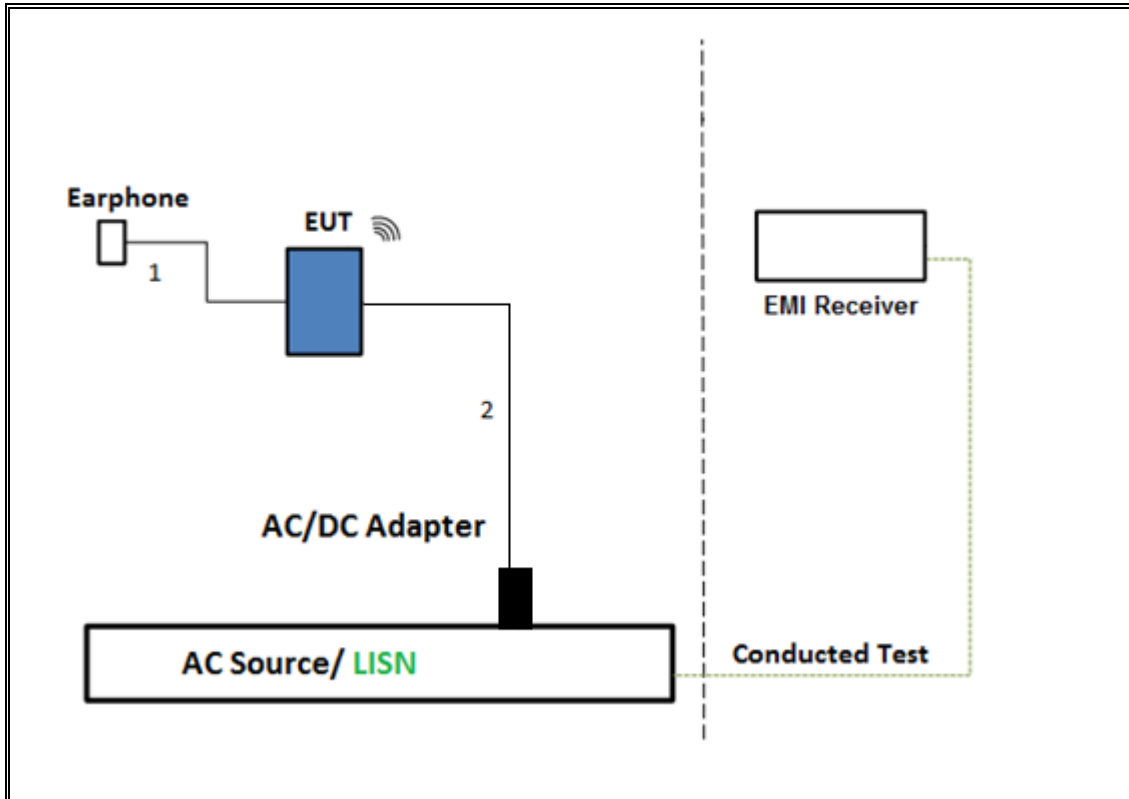

TEST SETUP- AC LINE CONDUCTED: LAPTOP CONFIGURATION

The EUT was tested with earphone connected and powered by host PC via USB cable. Test software exercised the EUT.

SETUP DIAGRAM

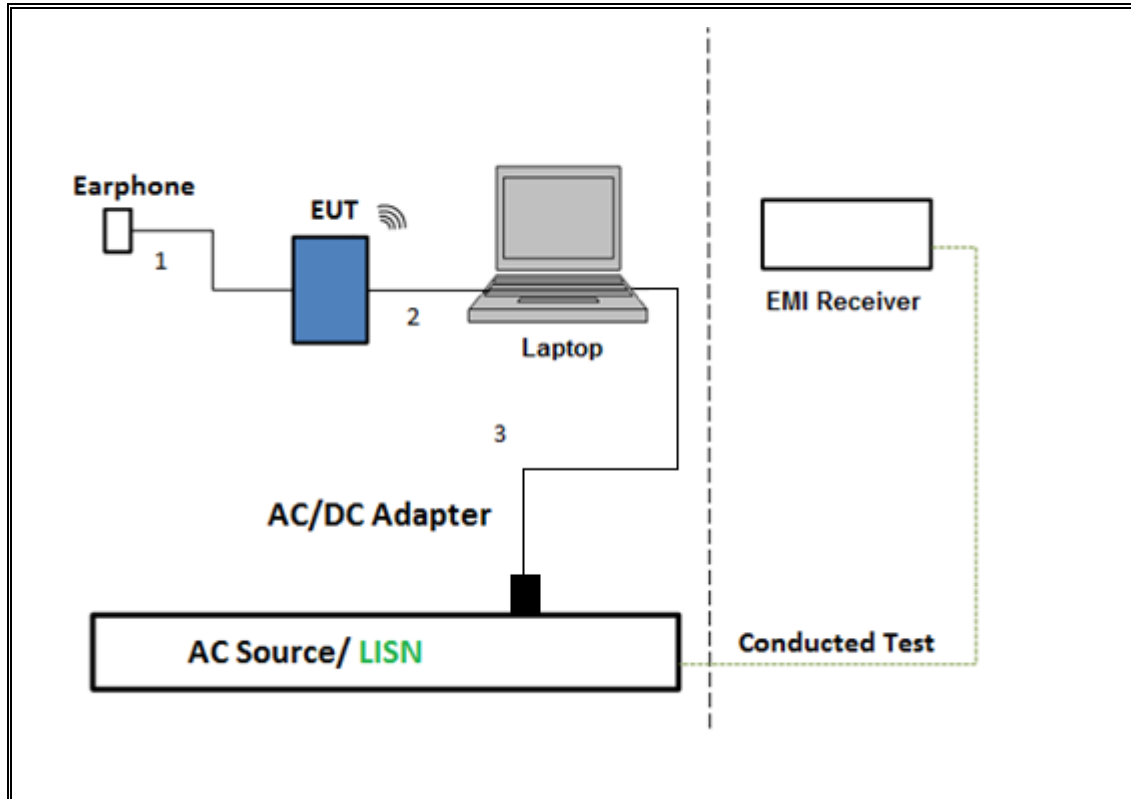

6. TEST AND MEASUREMENT EQUIPMENT

The following test and measurement equipment was utilized for the tests documented in this report:

TEST EQUIPMENT LIST				
Description	Manufacturer	Model	Asset	Cal Due
Antenna, Horn 1-18GHz	ETS Lindgren	3117	T344	02/22/2017
Antenna, Broadband Hybrid, 30MHz to 2000MHz	Sunol Sciences	JB3	T407	04/04/2017
Amplifier, 10KHz to 1GHz, 32dB	Sonoma	310N	T286	05/04/2017
Amplifier, 1 to 18GHz	Miteq	AFS42-00101800-25-S-42	T740	11/29/2017
Spectrum Analyzer, PXA 3Hz to 44GHz	Keysight	N9030A	T340	12/14/2017
Antenna, Broadband Hybrid, 30MHz to 2000MHz	Sunol Sciences	JB3	T899	05/26/2017
Amplifier, 10KHz to 1GHz, 32dB	Sonoma	310N	T834	06/17/2017
Spectrum Analyzer, PXA 3Hz to 44GHz	Keysight	N9030A-544	T1210	06/30/2017
Power Sensor, P - series, 50MHz to 18GHz, Wideband	Agilent	N1921A	T1228	06/20/2017
Power Meter, P-series single channel	Keysight	N1912A	T1273	07/08/2017
Spectrum Analyzer, PXA, 3Hz to 44GHz	Keysight	N9030A	T905	06/21/2017
Spectrum Analyzer, PSA, 3Hz to 44GHz	Keysight	E4446A	T123	10/20/2017
Spectrum Analyzer, PXA, 3Hz to 44GHz	Keysight	N9030A	T339	09/22/2017
Spectrum Analyzer	Keysight	8564E	T106	09/07/2017
Antenna, Horn 18 to 26.5GHz	ARA	MWH-1826/B	T447	06/16/2017
Amplifier, 1 to 26.5GHz, 23.5dB Gain minimum	Keysight	8449B	T402	07/05/2017
AC Line Conducted				
EMI Test Receiver 9KHz-7GHz	Rohde & Schwarz	ESCI7	T1124	10/07/2017
LISN for Conducted Emissions CISPR-16	Fischer	50/250-25-2-01	T1310	06/08/2017
Power Cable, Line Conducted Emissions	UL	PG1	T861	9/1/2017
UL AUTOMATION SOFTWARE				
Radiated Software	UL	UL EMC	Ver 9.5, April 26, 2016	
Conducted Software	UL	UL EMC	Ver 5.4, October 13, 2016	
AC Line Conducted Software	UL	UL EMC	Ver 9.5, May 26, 2015	

7. MEASUREMENT METHODS

On Time and Duty Cycle: ANSI C63.10-2013 Section 11.6

Occupied BW (99%): ANSI C63.10-2013 Section 6.9.3

Carrier Frequency Separation: ANSI C63.10-2013 Section 7.8.2

Number of Hopping Frequencies: ANSI C63.10-2013 Section 7.8.3

Time of Occupancy (Dwell Time): ANSI C63.10-2013 Section 7.8.4

Peak Output Power: ANSI C63.10-2013 Section 7.8.5

Conducted Spurious Emissions: ANSI C63.10-2013 Section 7.8.8

Conducted Band-Edge: ANSI C63.10-2013 Section 6.10.4

Radiated Spurious Emissions 30-1000MHz: ANSI C63.10-2013 Section 6.3 and 6.5

Radiated Spurious Emissions above 1GHz: ANSI C63.10-2013 Section 6.3 and 6.6

Radiated Band-edge: ANSI C63.10-2013 Section 6.10.5

AC Power-line conducted emissions: ANSI C63.10-2013, Section 6.2.

8. ANTENNA PORT TEST RESULTS

8.1. ON TIME AND DUTY CYCLE

LIMITS

None; for reporting purposes only.

PROCEDURE

ANSI C63.10, Section 11.6 : Zero-Span Spectrum Analyzer Method.

ON TIME AND DUTY CYCLE RESULTS

Mode	ON Time B (msec)	Period (msec)	Duty Cycle x (linear)	Duty Cycle (%)	Duty Cycle Correction Factor (dB)	1/B Minimum VBW (kHz)
GFSK HIGH POWER	1.000	1.000	1.000	100.00%	0.00	0.010
8PSK HIGH POWER	1.000	1.000	1.000	100.00%	0.00	0.010
GFSK LOW POWER	1.000	1.000	1.000	100.00%	0.00	0.010
8PSK LOW POWER	1.000	1.000	1.000	100.00%	0.00	0.010

DUTY CYCLE PLOTS

8.1.1. HIGH POWER MODE

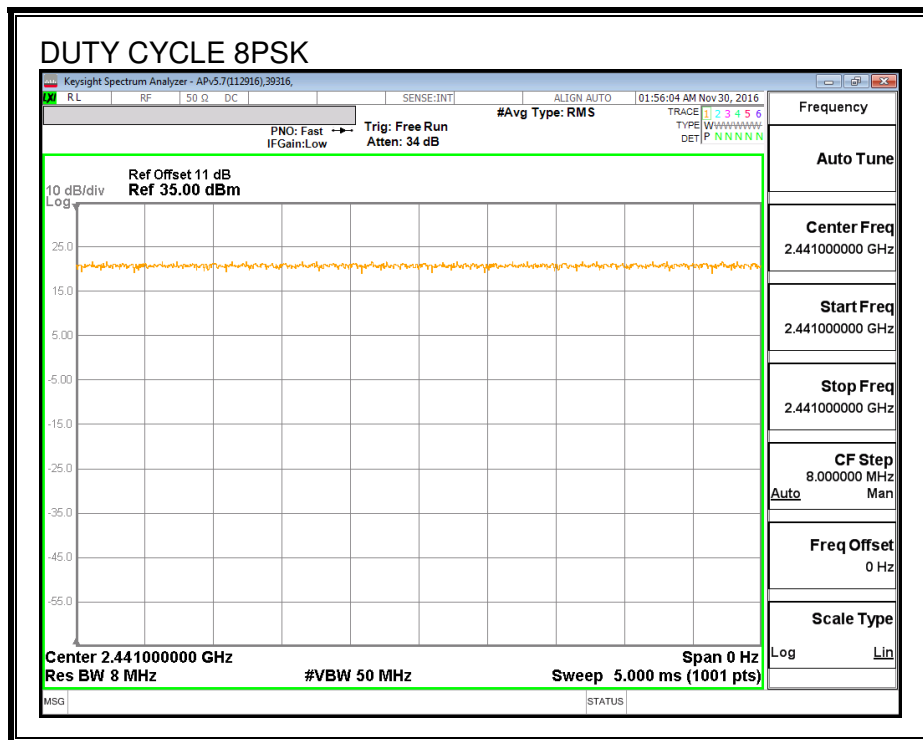
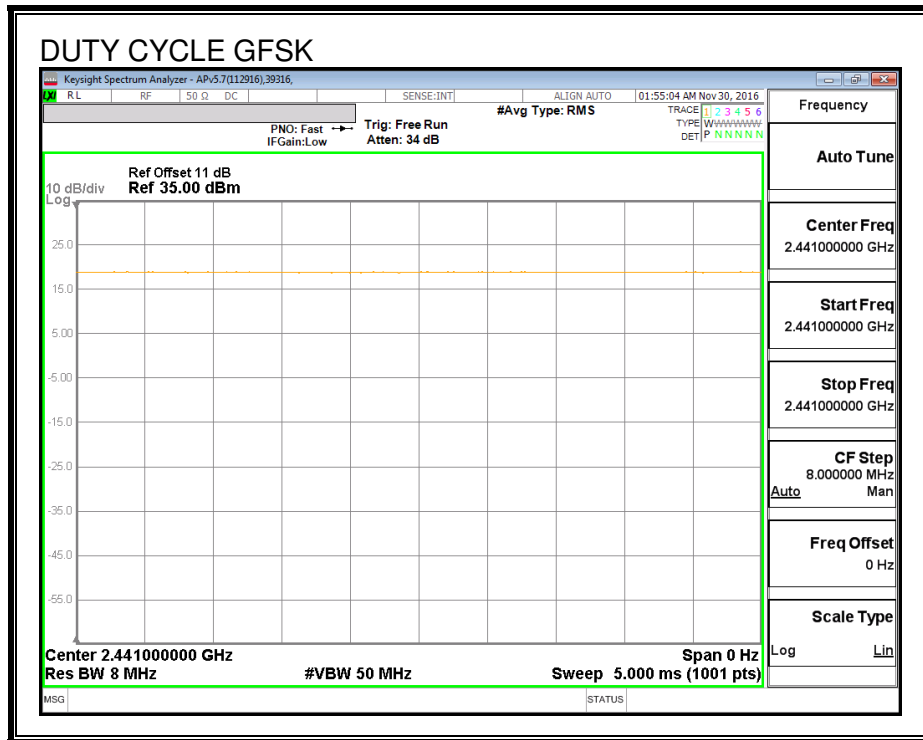

8.1.2. LOW POWER MODE

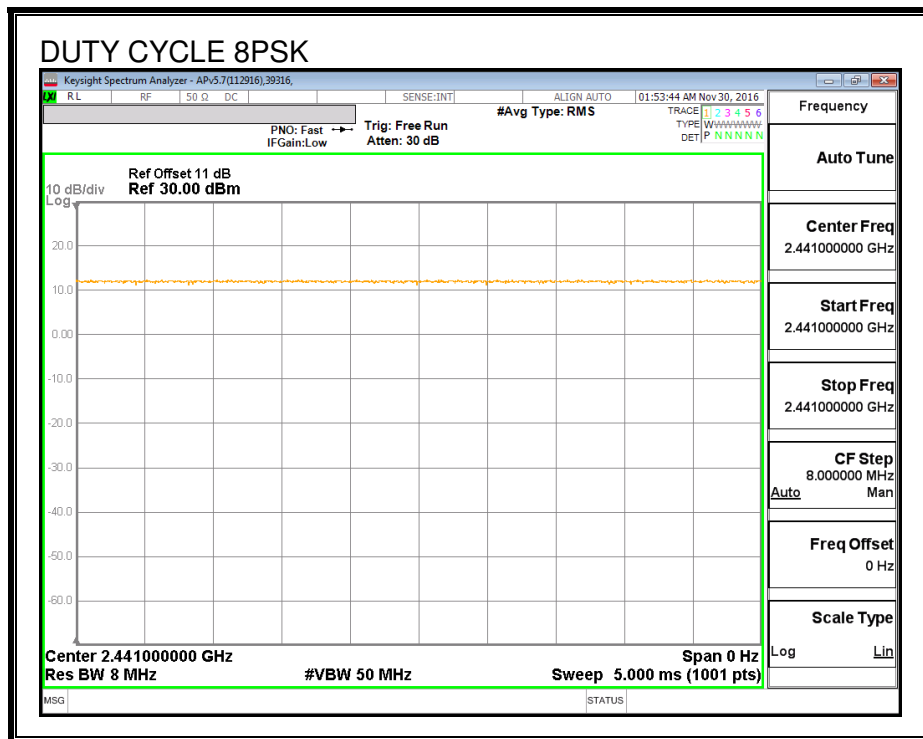
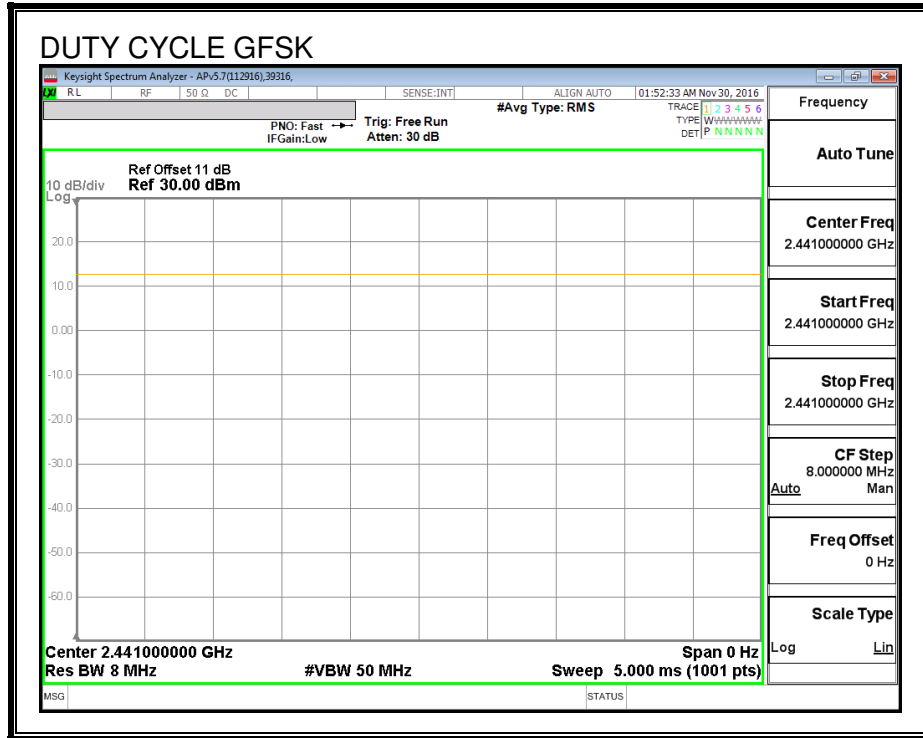

8.2. HIGH POWER BASIC DATA RATE GFSK MODULATION

8.2.1. 20 dB AND 99% BANDWIDTH

LIMITS

None; for reporting purposes only.

TEST PROCEDURE

The transmitter output is connected to a spectrum analyzer. The RBW is set to $\geq 1\%$ of the 20 dB bandwidth. The VBW is set to \geq RBW. The sweep time is coupled.

RESULTS

Channel	Frequency (MHz)	20 dB Bandwidth (KHz)	99% Bandwidth (KHz)
Low	2402	898.3	862.57
Middle	2441	950.2	900.35
High	2480	912.9	906.46

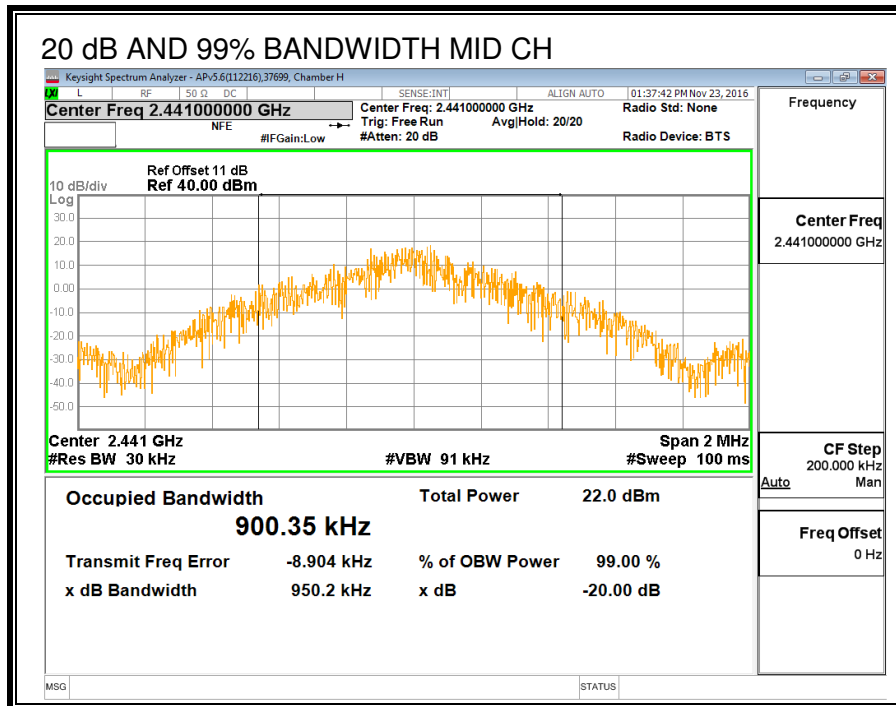
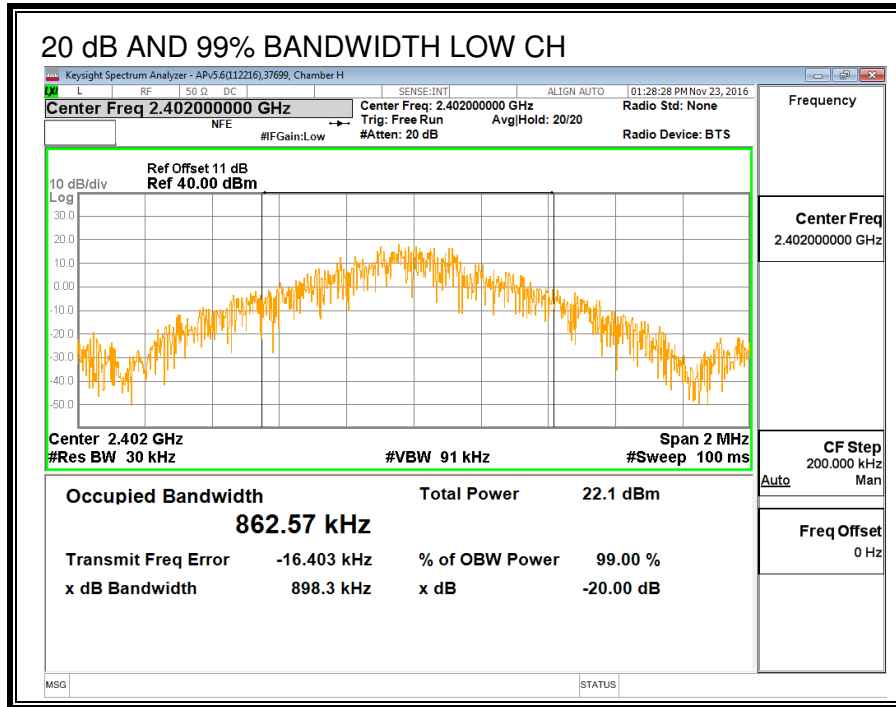

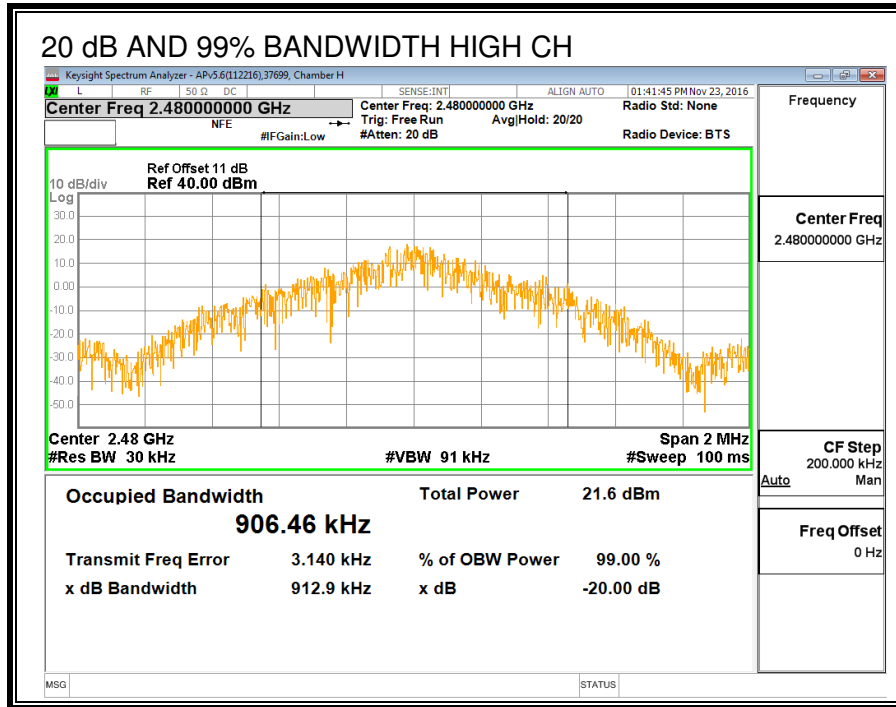

8.2.2. HOPPING FREQUENCY SEPARATION

LIMITS

FCC §15.247 (a) (1)

IC RSS-247 (5.1) (2)

Frequency hopping systems shall have hopping channel carrier frequencies separated by a minimum of 25 kHz or the 20 dB bandwidth of the hopping channel, whichever is greater.

Alternatively, frequency hopping systems operating in the 2400-2483.5 MHz band may have hopping channel carrier frequencies that are separated by 25 kHz or two-thirds of the 20 dB bandwidth of the hopping channel, whichever is greater, provided the systems operate with an output power no greater than 125 mW.

TEST PROCEDURE

The transmitter output is connected to a spectrum analyzer. The RBW is set to 300 kHz and the VBW is set to 910 kHz. The sweep time is coupled.

RESULTS

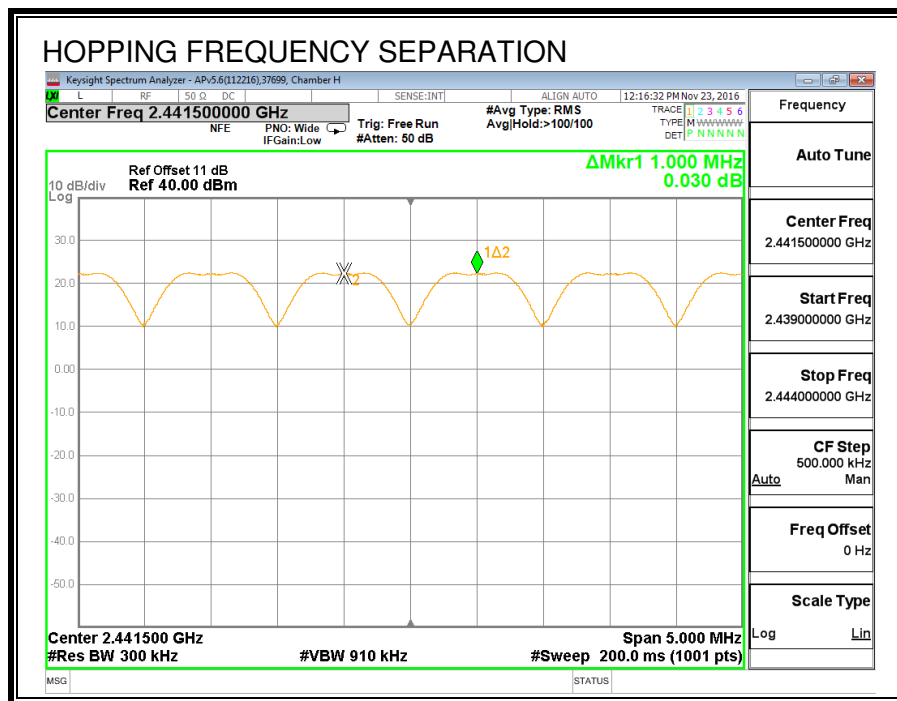

8.2.3. NUMBER OF HOPPING CHANNELS

LIMITS

FCC §15.247 (a) (1) (iii)

IC RSS-247 (5.1) (4)

Frequency hopping systems in the 2400 – 2483.5 MHz band shall use at least 15 non-overlapping channels.

TEST PROCEDURE

The transmitter output is connected to a spectrum analyzer. The span is set to cover the entire authorized band, in either a single sweep or in multiple contiguous sweeps. The RBW is set to a maximum of 1 % of the span. The analyzer is set to Max Hold.

RESULTS

Normal Mode: 79 Channels observed.

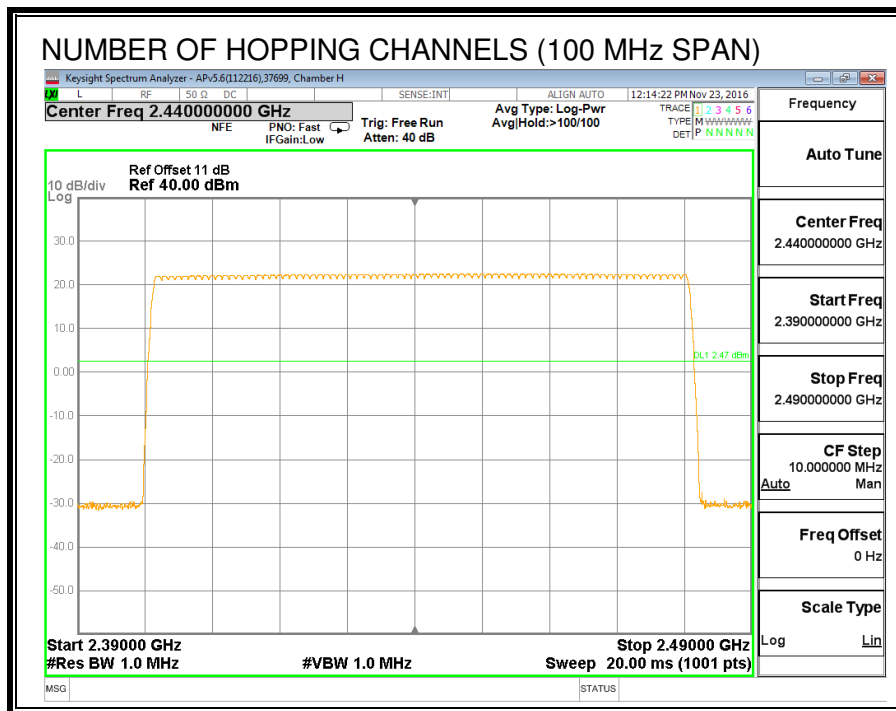

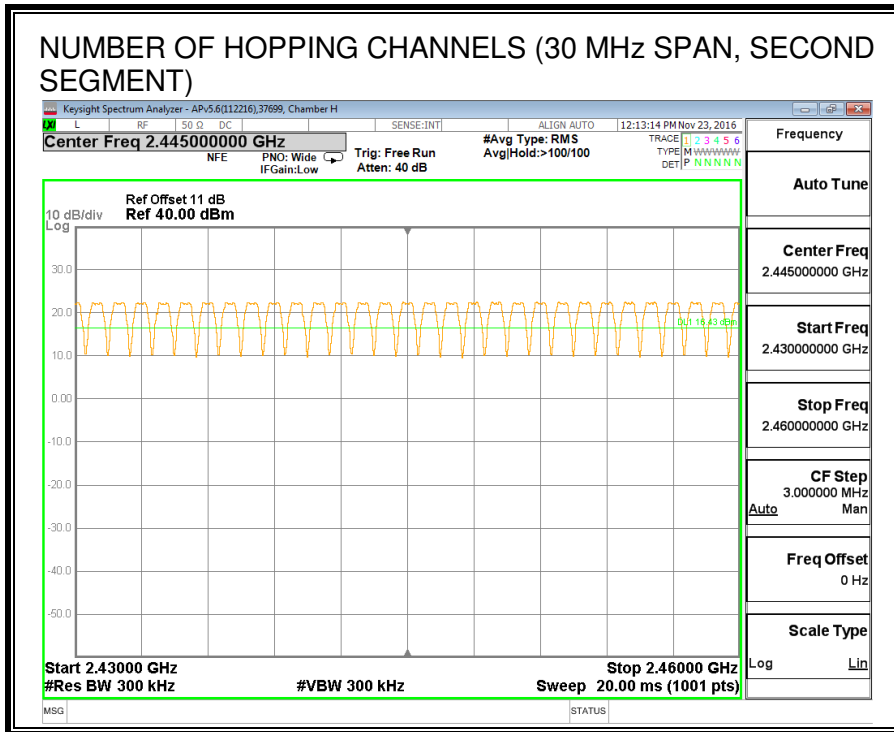
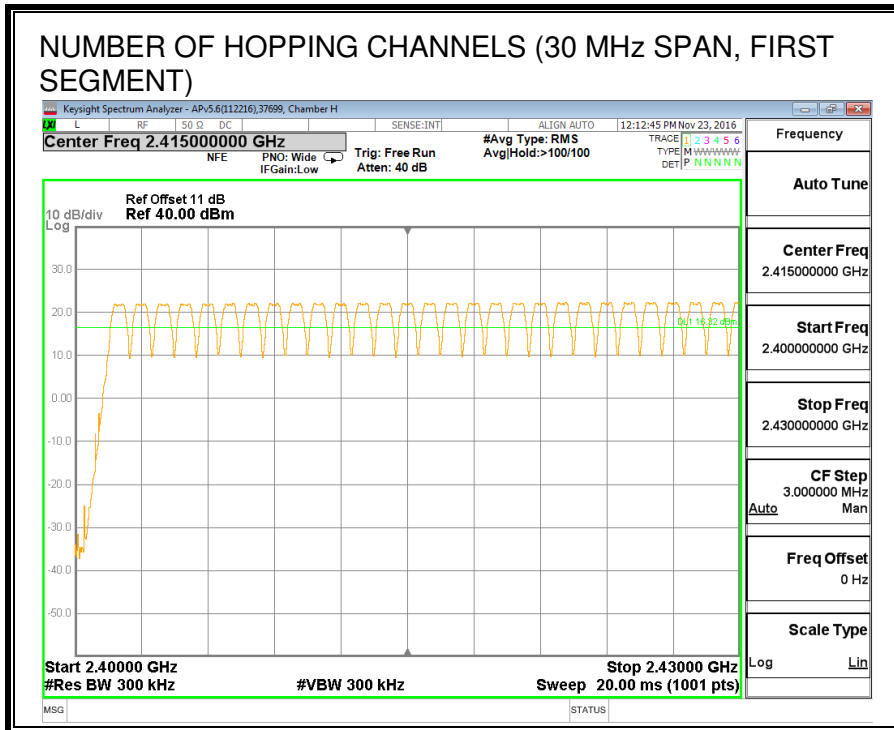

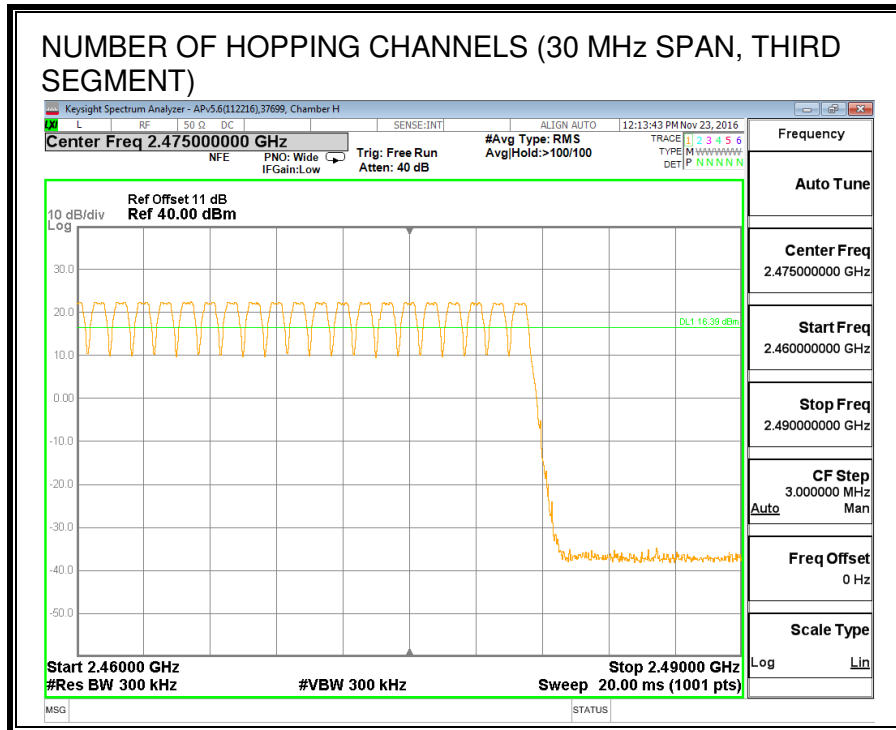

8.2.4. AVERAGE TIME OF OCCUPANCY

LIMITS

FCC §15.247 (a) (1) (iii)

IC RSS-247 (5.1) (4)

The average time of occupancy on any channel shall not be greater than 0.4 seconds within a period of 0.4 seconds multiplied by the number of hopping channels employed.

TEST PROCEDURE

The transmitter output is connected to a spectrum analyzer. The span is set to 0 Hz, centered on a single, selected hopping channel. The width of a single pulse is measured in a fast scan. The number of pulses is measured in a 3.16 second scan, to enable resolution of each occurrence.

The average time of occupancy in the specified 31.6 second period (79 channels * 0.4 s) is equal to $10 * (\# \text{ of pulses in } 3.16 \text{ s}) * \text{ pulse width}$.

For AFH mode, the average time of occupancy in the specified 8 second period (20 channels * 0.4 seconds) is equal to $10 * (\# \text{ of pulses in } 0.8 \text{ s}) * \text{ pulse width}$.

RESULTS

DH Packet	Pulse Width (msec)	Number of Pulses in 3.16 seconds	Average Time of Occupancy (sec)	Limit (sec)	Margin (sec)
GFSK Normal Mode					
DH1	0.385	32	0.123	0.4	-0.277
DH3	1.64	18	0.295	0.4	-0.105
DH5	2.888	12	0.347	0.4	-0.053
DH Packet	Pulse Width (msec)	Number of Pulses in 0.8 seconds	Average Time of Occupancy (sec)	Limit (sec)	Margin (sec)
GFSK AFH Mode					
DH1	0.385	8	0.031	0.4	-0.369
DH3	1.64	4.5	0.074	0.4	-0.326
DH5	2.888	3	0.087	0.4	-0.313

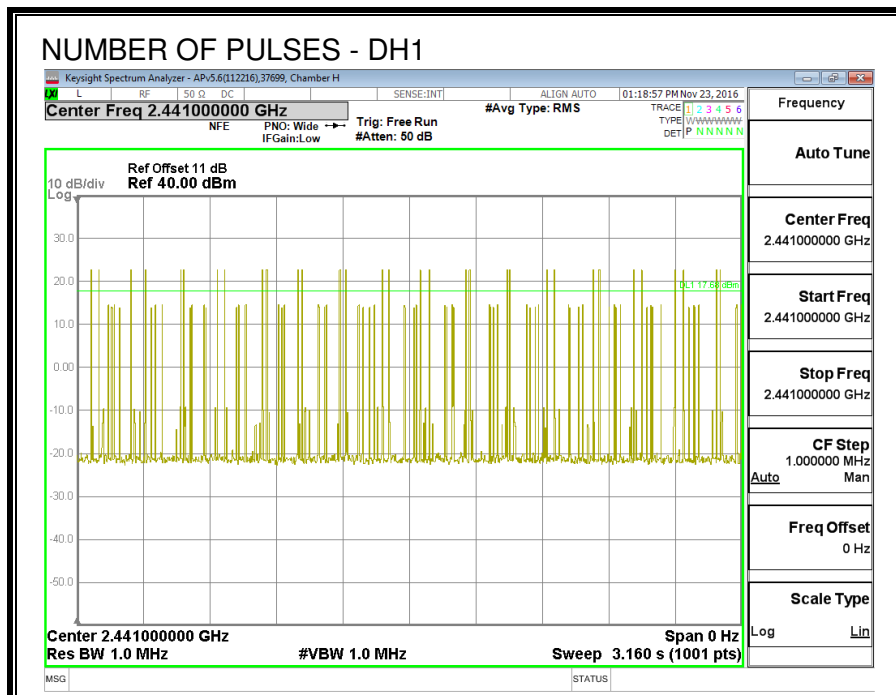
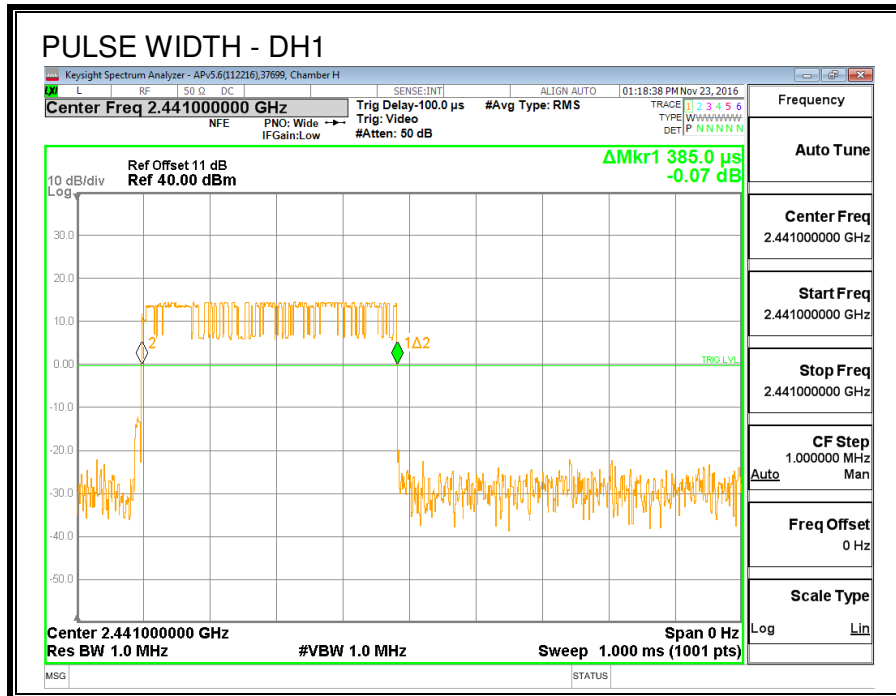

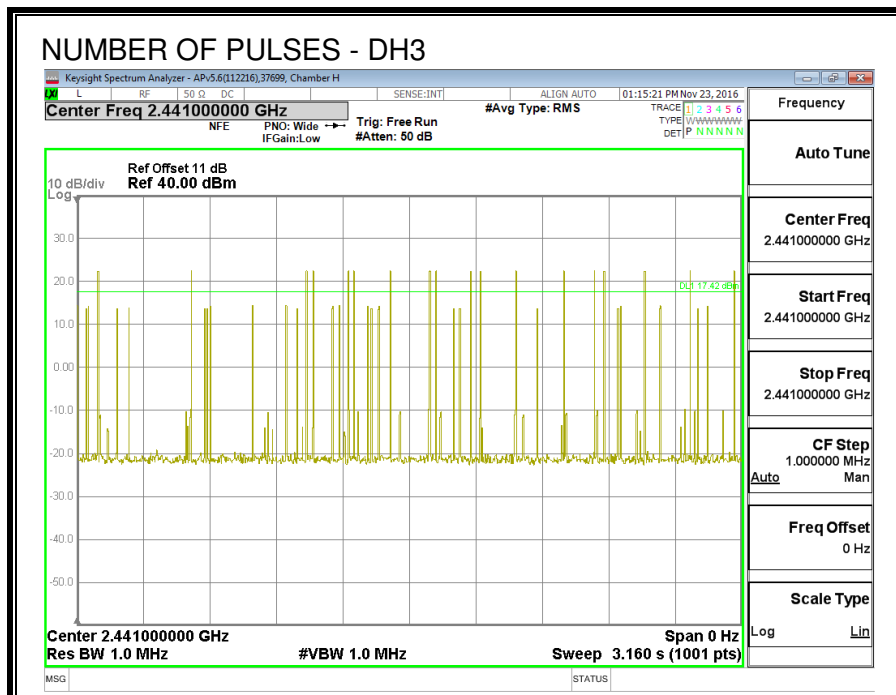

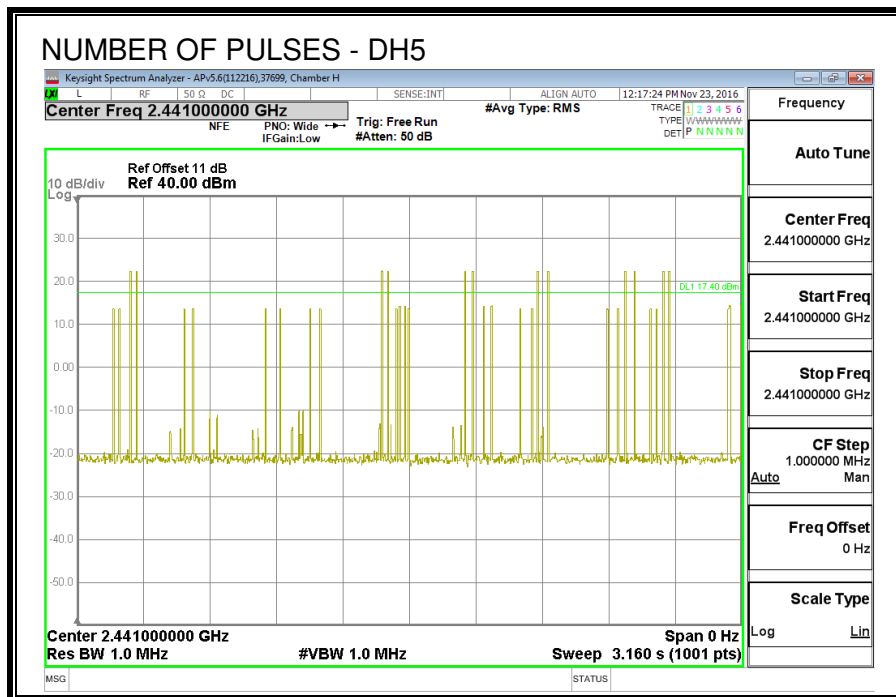
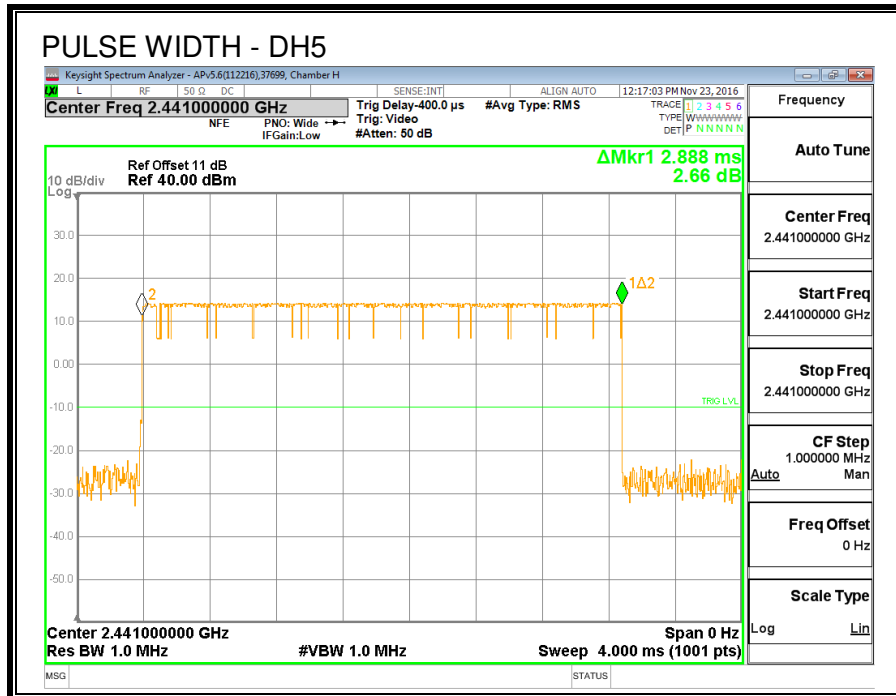

8.2.5. OUTPUT POWER

ID:	39316	Date:	1/20/17
-----	-------	-------	---------

LIMITS

§15.247 (b) (1)

RSS-247 (5.4) (2)

The maximum antenna gain is less than 6 dBi, therefore the limit is 30 dBm.

TEST PROCEDURE

The transmitter output is connected to a wideband peak and average power meter.

RESULTS

Channel	Frequency (MHz)	Output Power (dBm)	Limit (dBm)	Margin (dB)
Low	2402	17.17	30	-12.80
Middle	2441	17.05	30	-12.99
High	2480	17.20	30	-12.80

8.2.6. AVERAGE POWER

ID:	39316	Date:	1/20/17
-----	-------	-------	---------

LIMITS

None; for reporting purposes only.

TEST PROCEDURE

The transmitter output is connected to a power meter.

RESULTS

The cable assembly insertion loss of 11 dB (including 10 dB pad and 1 dB cable) was entered as an offset in the power meter to allow for direct reading of power.

Channel	Frequency (MHz)	Average Power (dBm)
Low	2402	16.89
Middle	2441	16.80
High	2480	16.90

8.2.7. CONDUCTED BANDEDGE AND SPURIOUS EMISSIONS

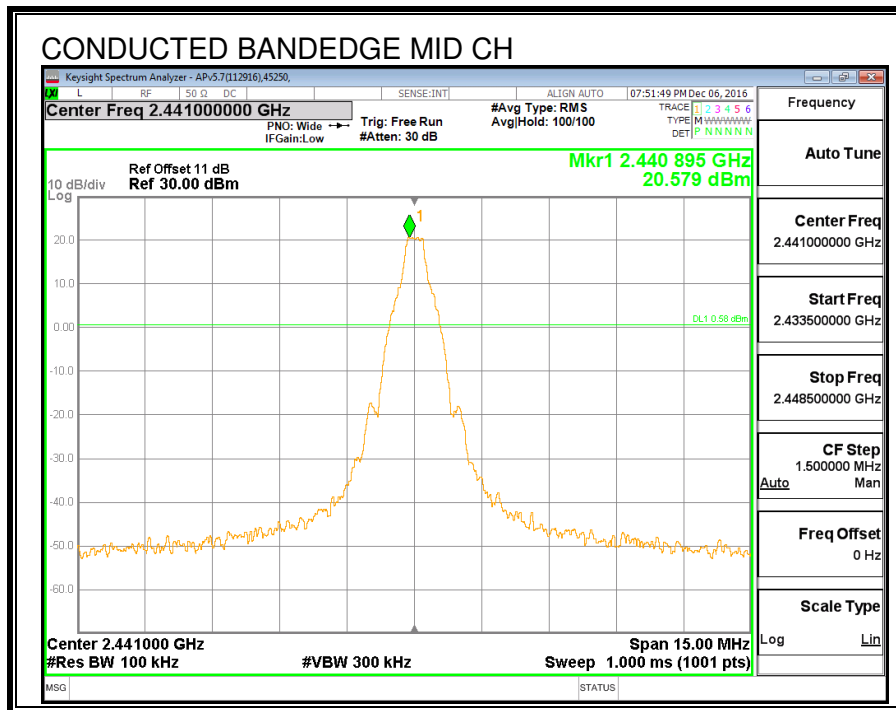
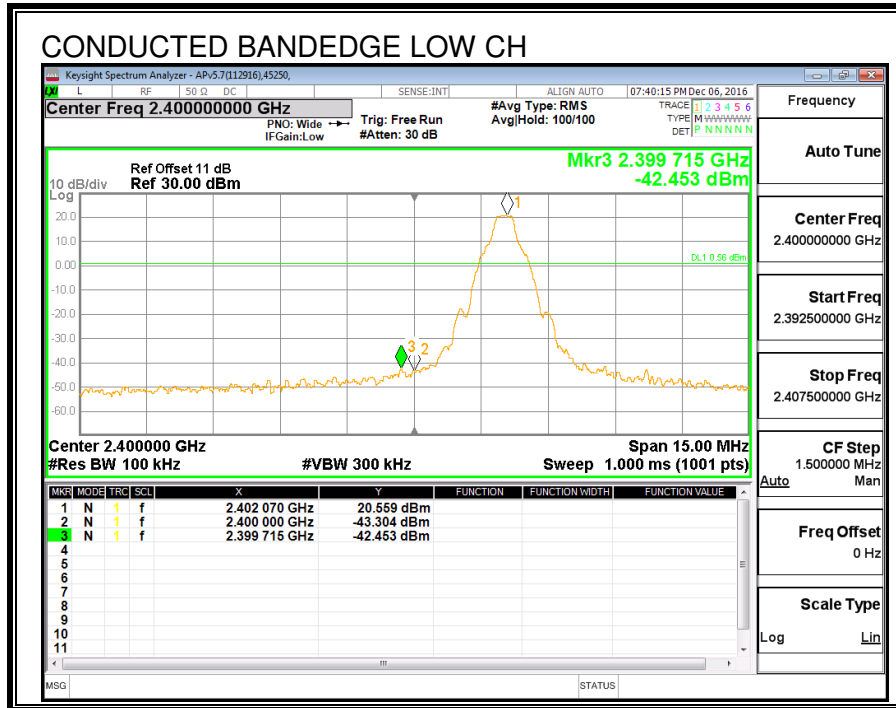

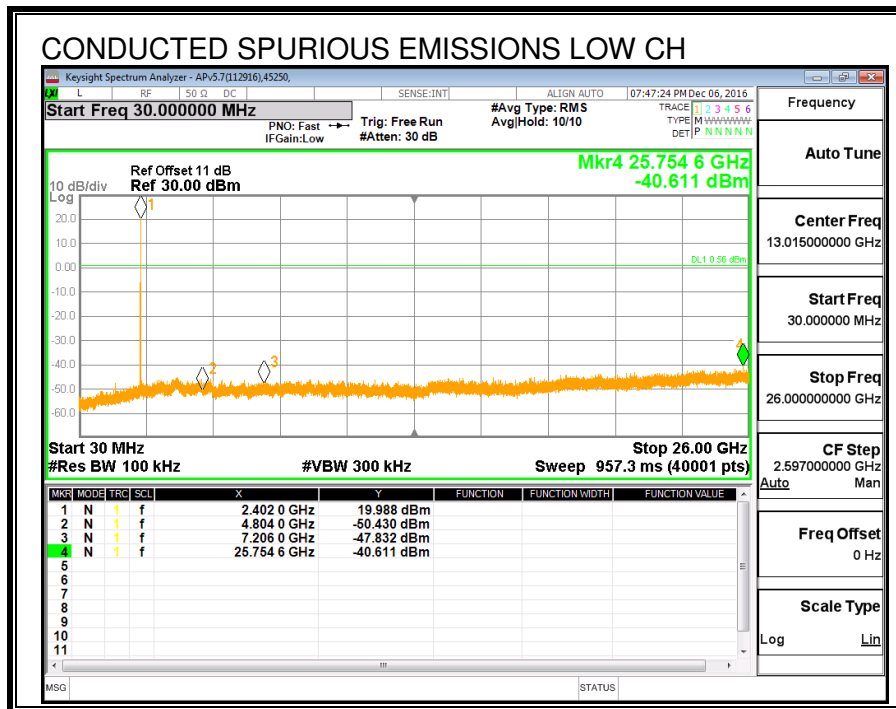
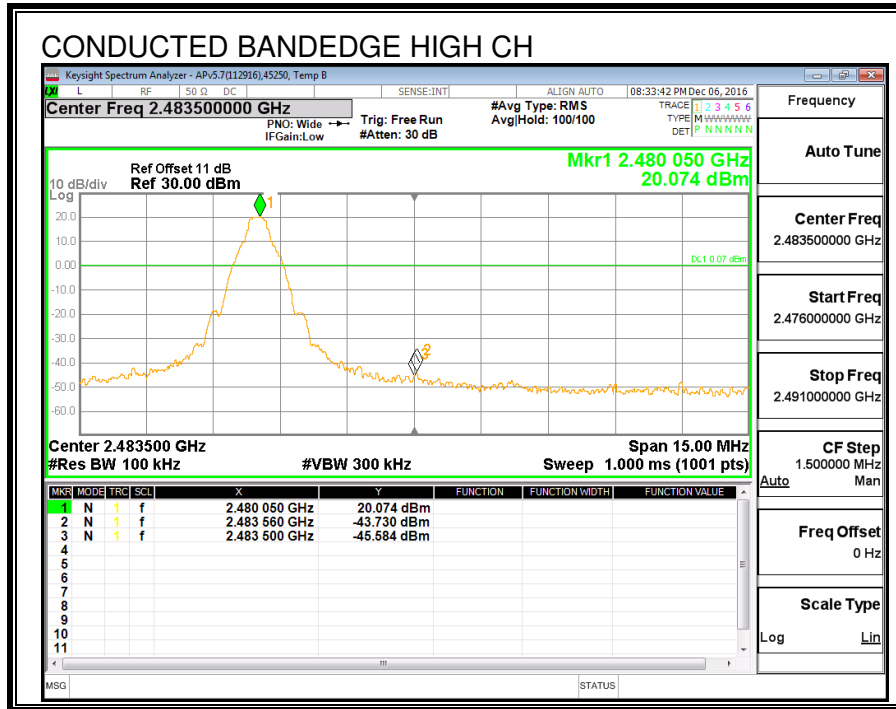

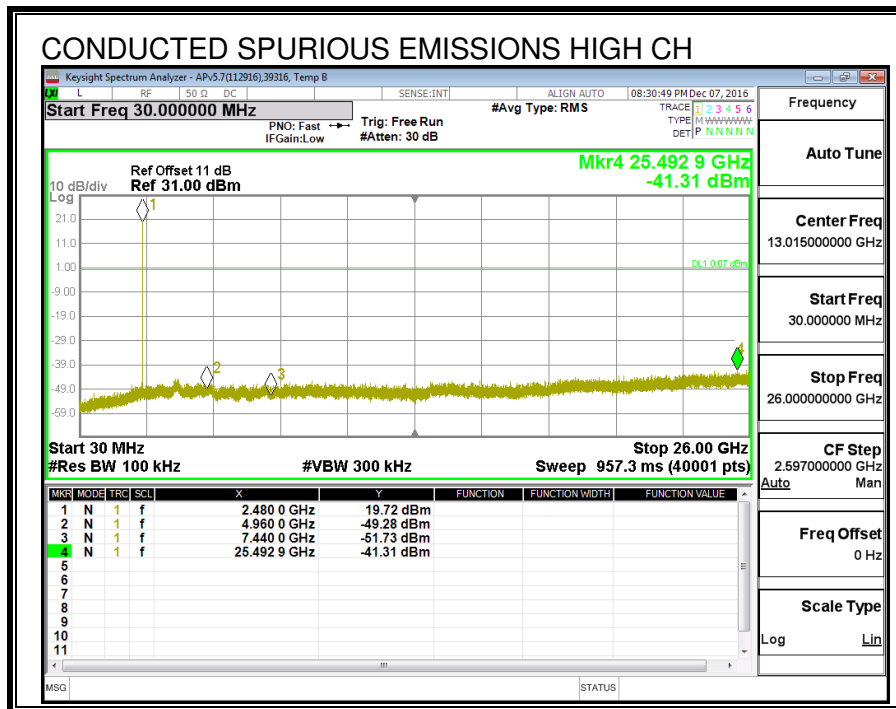
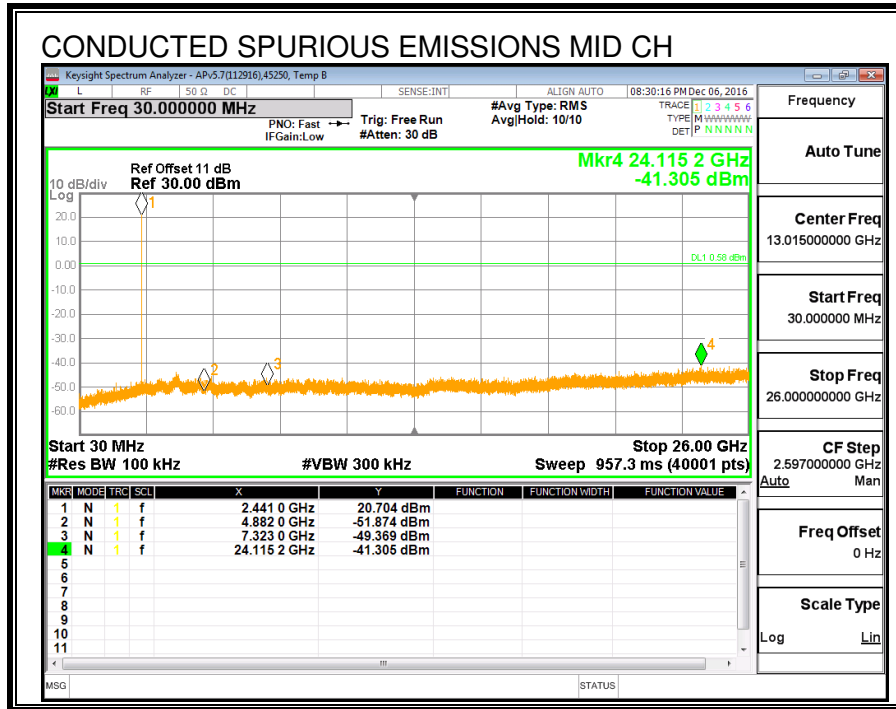

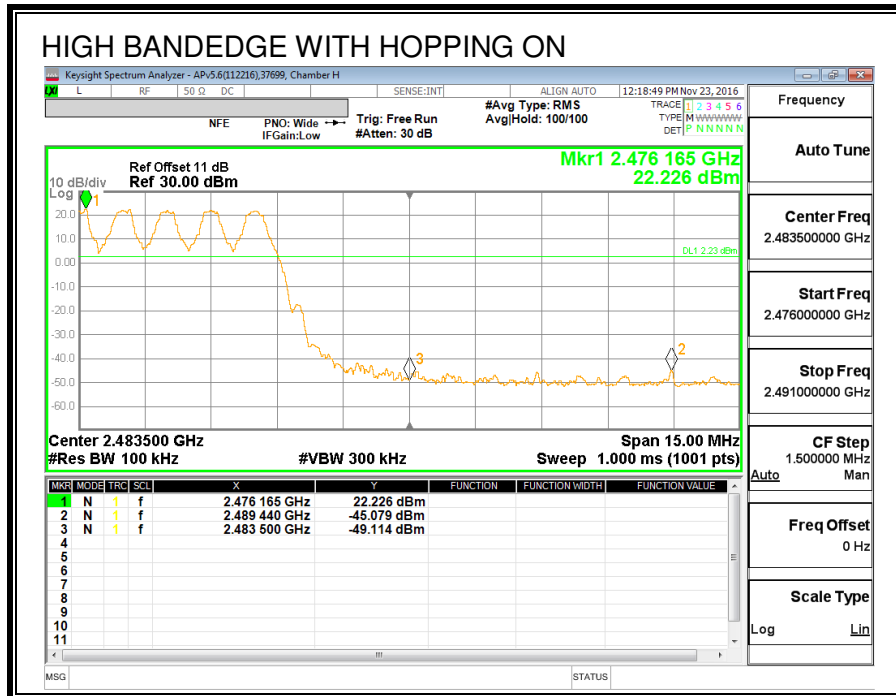
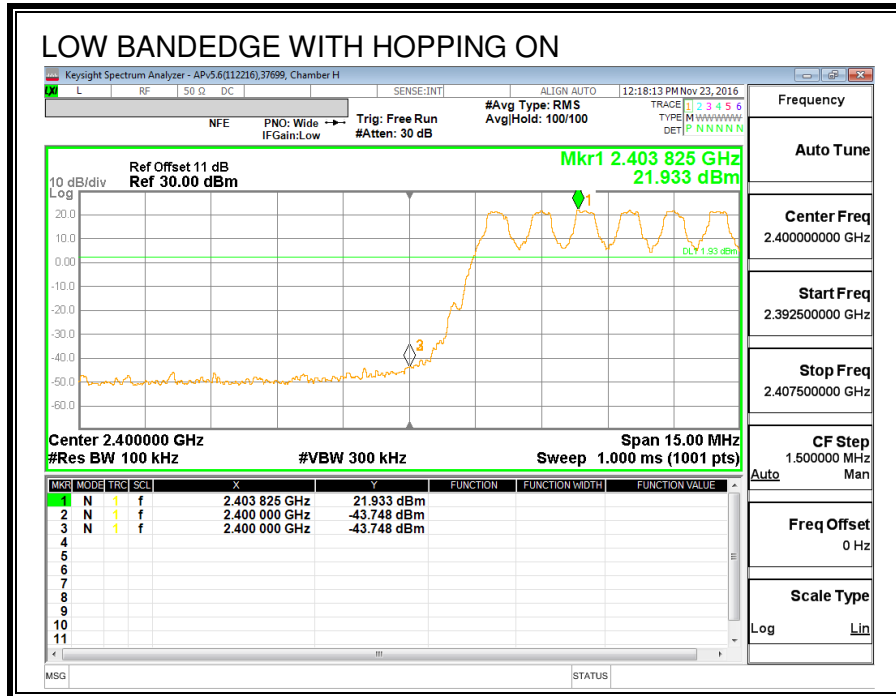

8.3. HIGH POWER ENHANCED DATA RATE DQPSK MODULATION

8.3.1. OUTPUT POWER

ID:	39316	Date:	1/20/17
-----	-------	-------	---------

LIMITS

§15.247 (b) (1)

RSS-247 (5.4) (2)

The maximum antenna gain is less than 6 dBi, therefore the limit is 30 dBm.

TEST PROCEDURE

The transmitter output is connected to a wideband peak and average power meter.

RESULTS

Channel	Frequency (MHz)	Output Power (dBm)	Limit (dBm)	Margin (dB)
Low	2402	19.05	21	-1.95
Middle	2441	19.20	21	-1.80
High	2480	19.00	21	-2.00

8.3.2. AVERAGE POWER

ID:	39316	Date:	1/20/17
-----	-------	-------	---------

LIMITS

None; for reporting purposes only.

TEST PROCEDURE

The transmitter output is connected to a power meter.

RESULTS

The cable assembly insertion loss of 11 dB (including 10 dB pad and 1 dB cable) was entered as an offset in the power meter to allow for direct reading of power.

Channel	Frequency (MHz)	Average Power (dBm)
Low	2402	15.75
Middle	2441	15.80
High	2480	15.70

8.4. HIGH POWER ENHANCED DATA RATE 8PSK MODULATION

8.4.1. 20 dB AND 99% BANDWIDTH

LIMITS

None; for reporting purposes only.

TEST PROCEDURE

The transmitter output is connected to a spectrum analyzer. The RBW is set to $\geq 1\%$ of the 20 dB bandwidth. The VBW is set to \geq RBW. The sweep time is coupled.

RESULTS

Channel	Frequency (MHz)	20 dB Bandwidth (KHz)	99% Bandwidth (KHz)
Low	2402	1336	1214.9
Middle	2441	1300	1214.4
High	2480	1291	1228.3

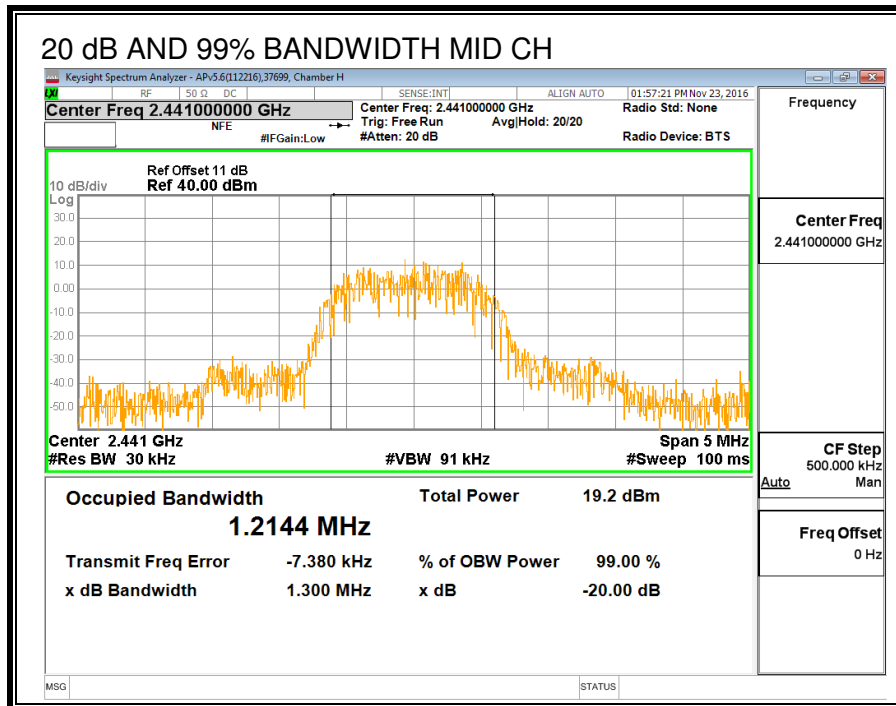
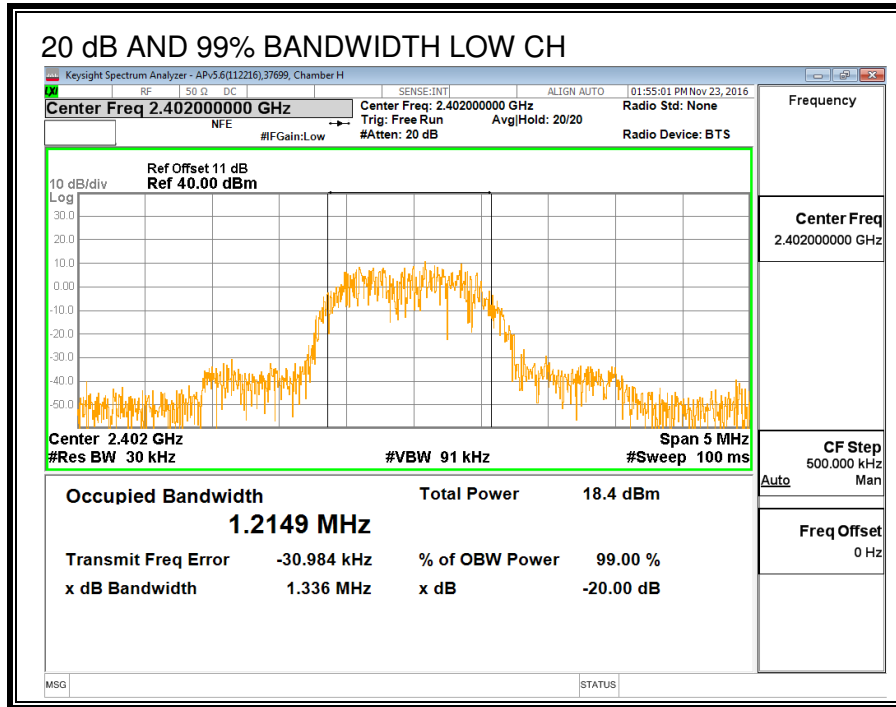

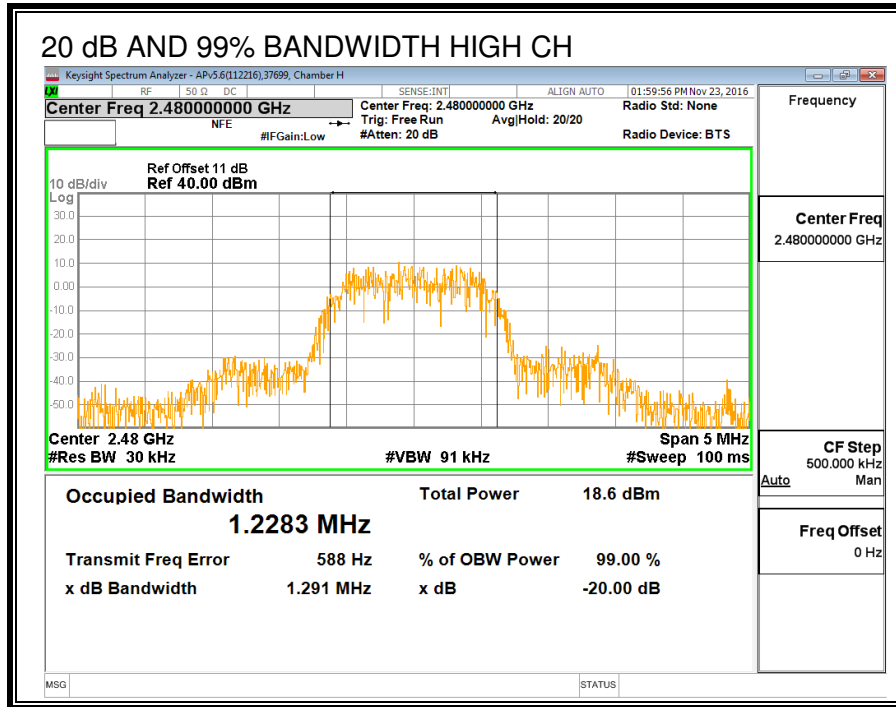

8.4.2. HOPPING FREQUENCY SEPARATION

LIMITS

FCC §15.247 (a) (1)

IC RSS-247 (5.1) (2)

Frequency hopping systems shall have hopping channel carrier frequencies separated by a minimum of 25 kHz or the 20 dB bandwidth of the hopping channel, whichever is greater.

Alternatively, frequency hopping systems operating in the 2400-2483.5 MHz band may have hopping channel carrier frequencies that are separated by 25 kHz or two-thirds of the 20 dB bandwidth of the hopping channel, whichever is greater, provided the systems operate with an output power no greater than 125 mW.

TEST PROCEDURE

The transmitter output is connected to a spectrum analyzer. The RBW is set to 300 kHz and the VBW is set to 910 kHz. The sweep time is coupled.

RESULTS

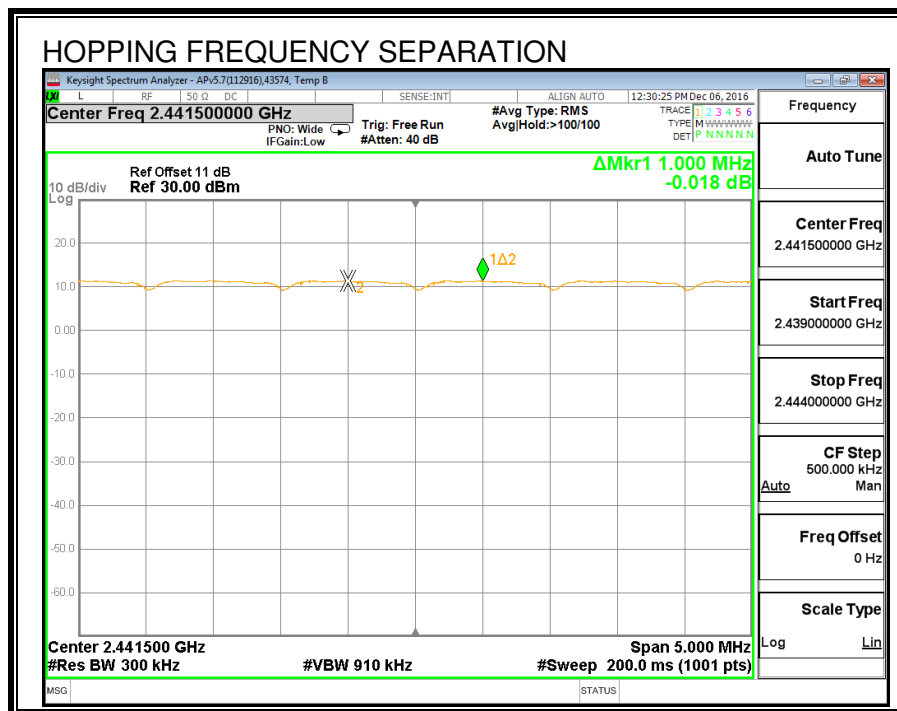

8.4.3. NUMBER OF HOPPING CHANNELS

LIMITS

FCC §15.247 (a) (1) (iii)

IC RSS-247 (5.1) (4)

Frequency hopping systems in the 2400 – 2483.5 MHz band shall use at least 15 non-overlapping channels.

TEST PROCEDURE

The transmitter output is connected to a spectrum analyzer. The span is set to cover the entire authorized band, in either a single sweep or in multiple contiguous sweeps. The RBW is set to a maximum of 1 % of the span. The analyzer is set to Max Hold.

RESULTS

Normal Mode: 79 Channels observed.

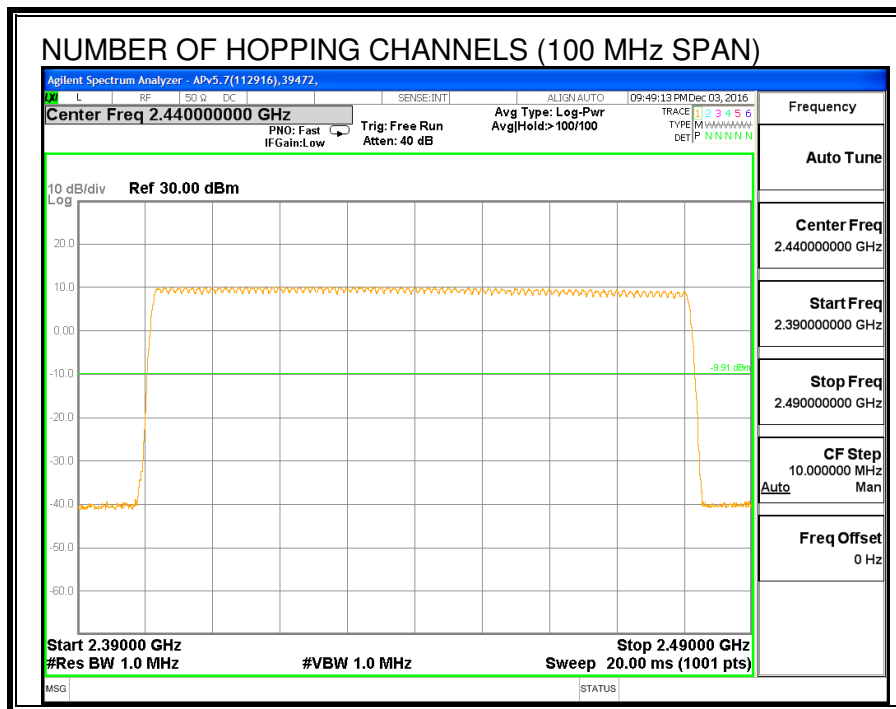

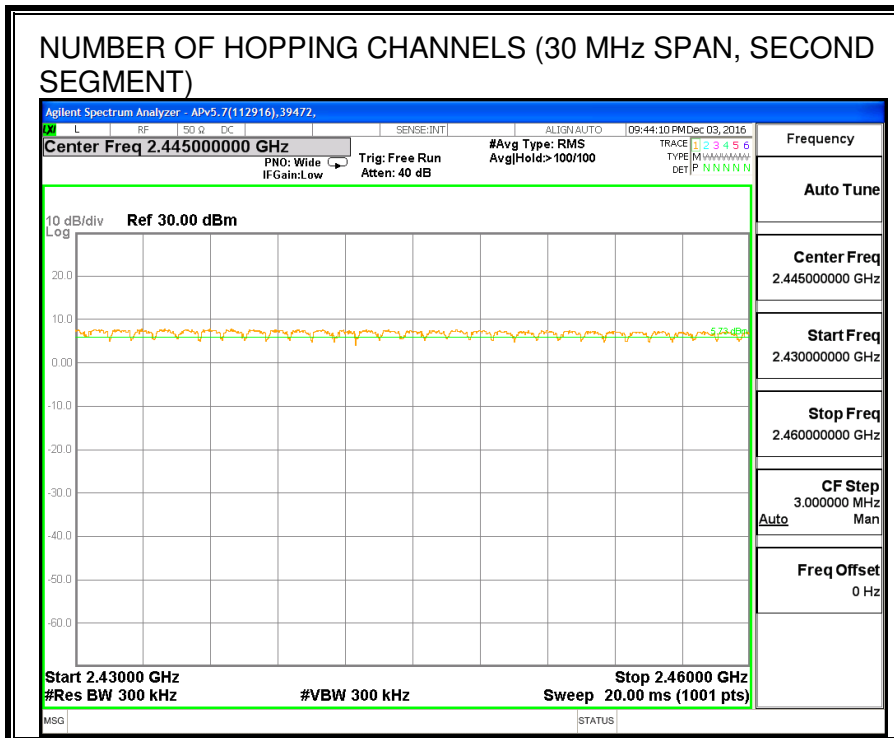
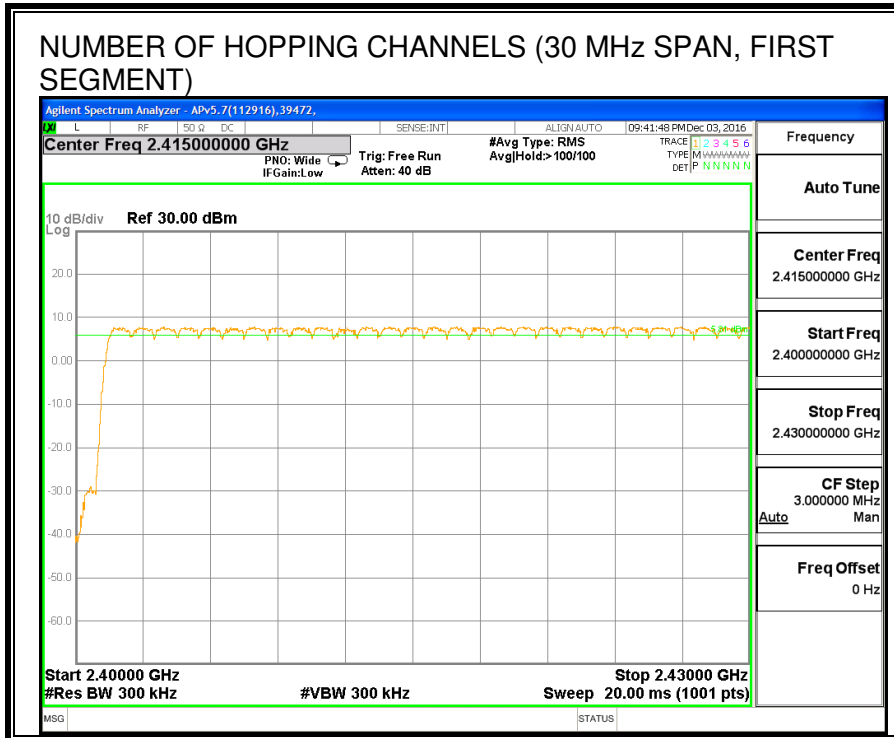

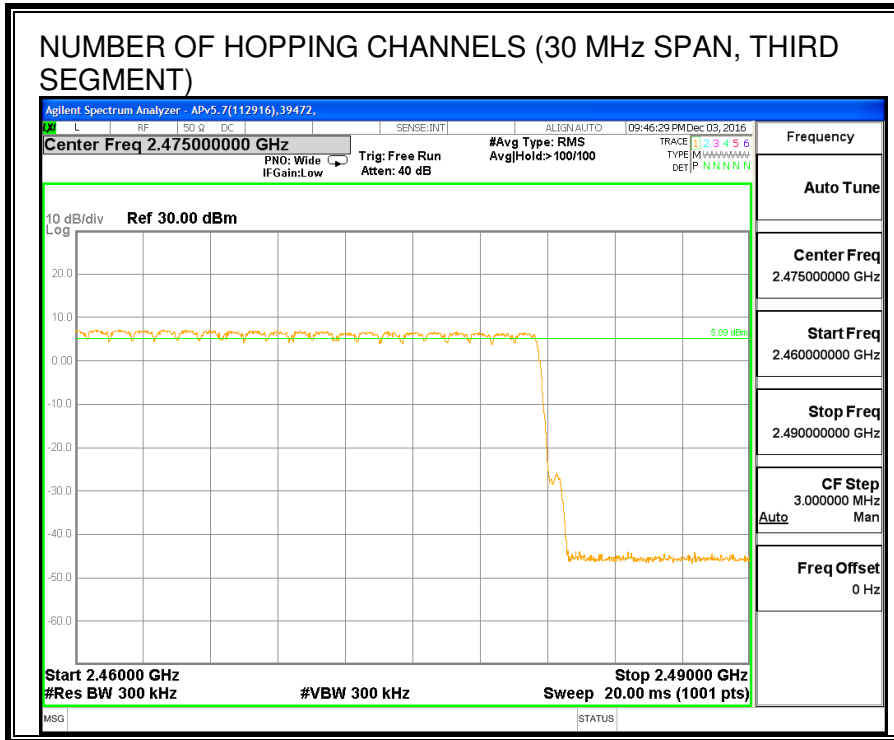

8.4.4. AVERAGE TIME OF OCCUPANCY

LIMITS

FCC §15.247 (a) (1) (iii)

IC RSS-247 (5.1) (4)

The average time of occupancy on any channel shall not be greater than 0.4 seconds within a period of 0.4 seconds multiplied by the number of hopping channels employed.

TEST PROCEDURE

The transmitter output is connected to a spectrum analyzer. The span is set to 0 Hz, centered on a single, selected hopping channel. The width of a single pulse is measured in a fast scan. The number of pulses is measured in a 3.16 second scan, to enable resolution of each occurrence.

The average time of occupancy in the specified 31.6 second period (79 channels * 0.4 s) is equal to $10 * (\# \text{ of pulses in } 3.16 \text{ s}) * \text{ pulse width}$.

For AFH mode, the average time of occupancy in the specified 8 second period (20 channels * 0.4 seconds) is equal to $10 * (\# \text{ of pulses in } 0.8 \text{ s}) * \text{ pulse width}$.

RESULTS

DH Packet	Pulse Width (msec)	Number of Pulses in 3.16 seconds	Average Time of Occupancy (sec)	Limit (sec)	Margin (sec)
8PSK Normal Mode					
3DH1	0.391	31	0.121	0.4	-0.279
3DH3	1.642	14	0.230	0.4	-0.170
3DH5	2.888	10	0.289	0.4	-0.111

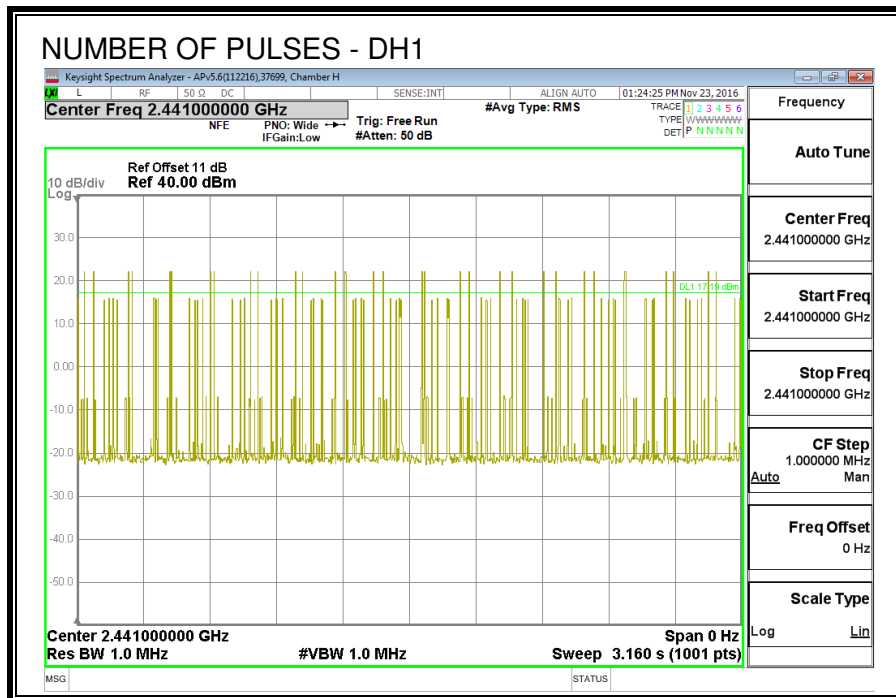
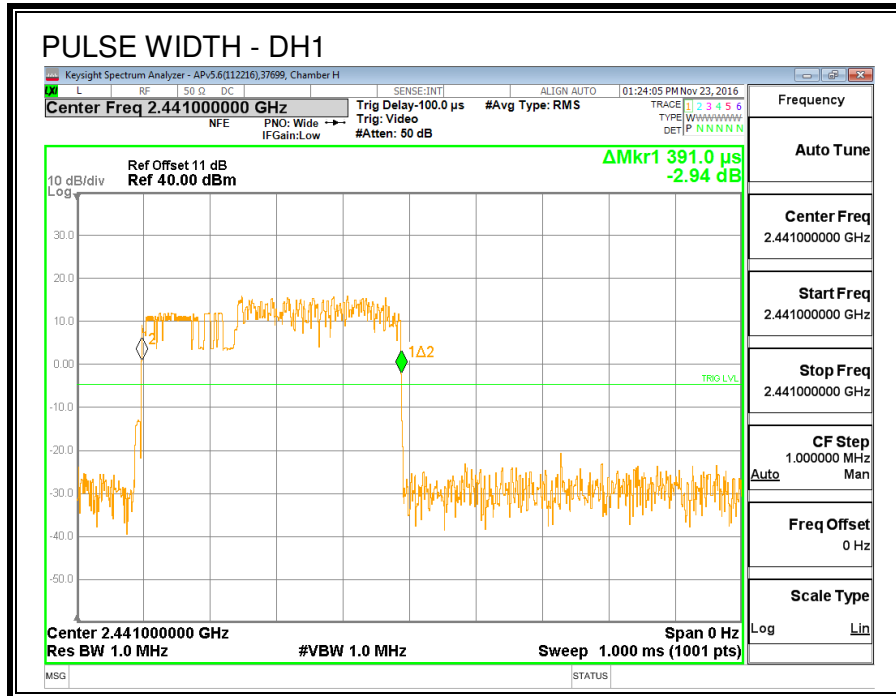

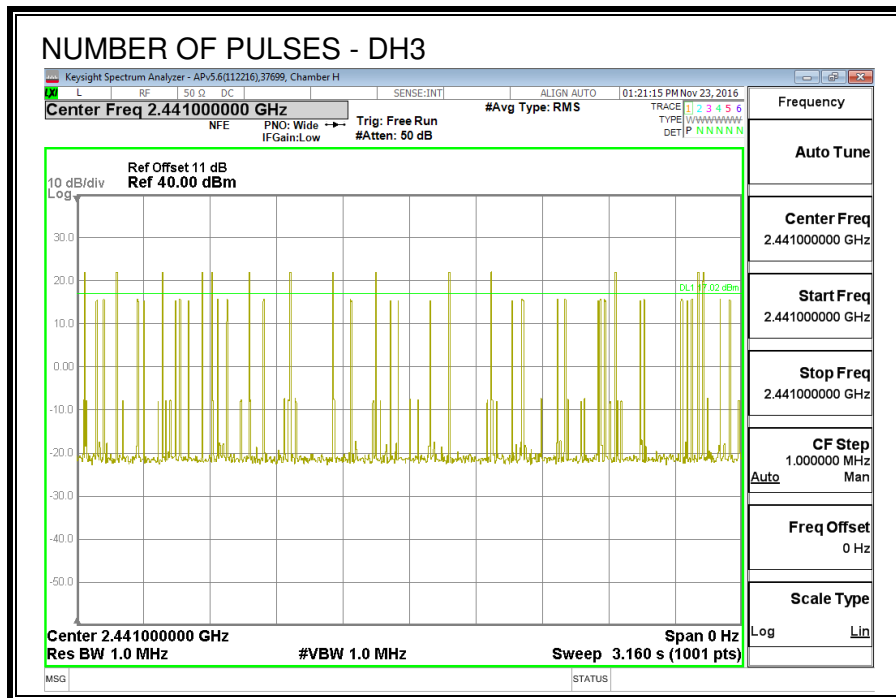
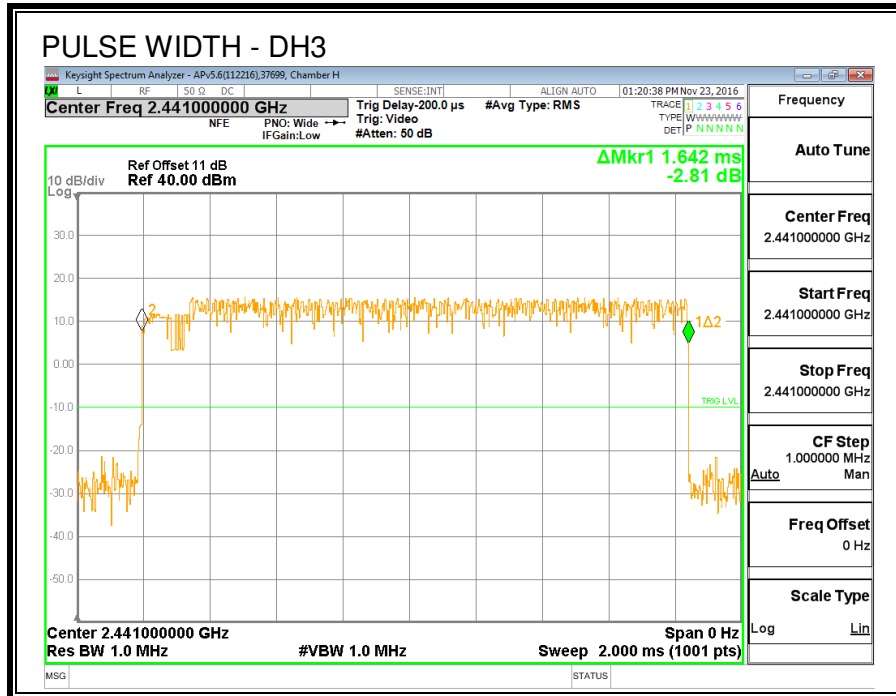

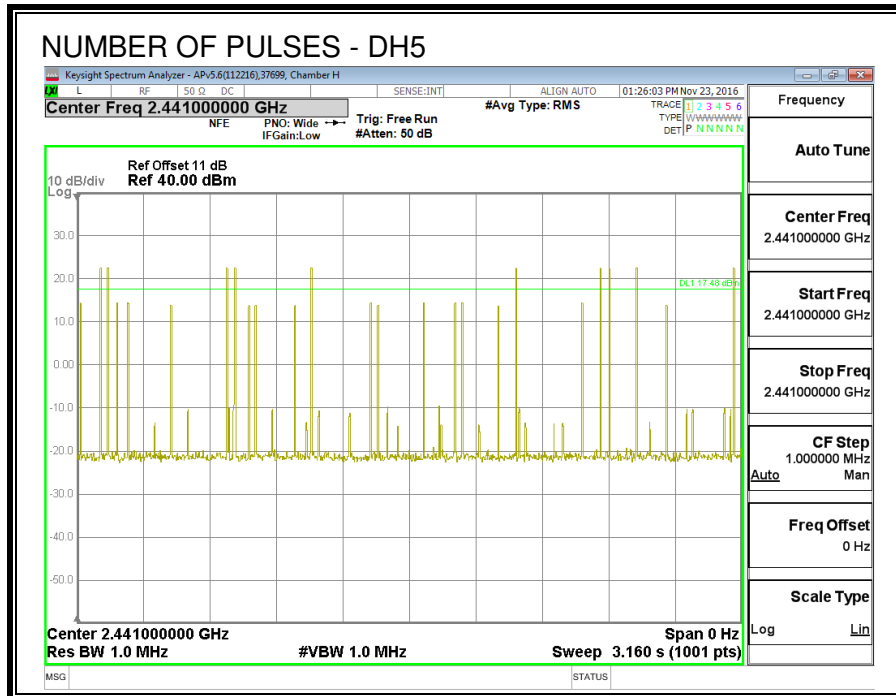
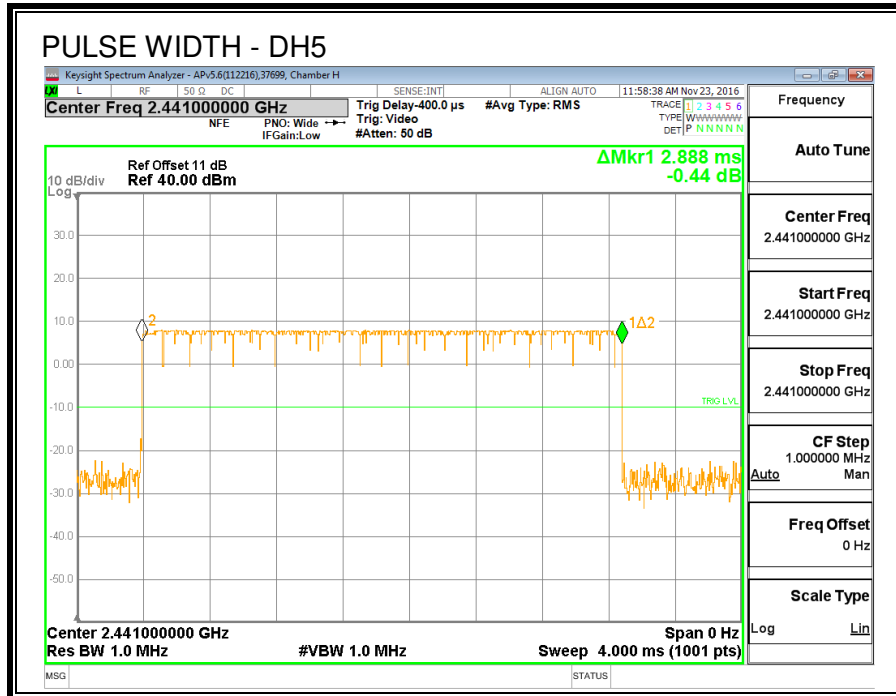

8.4.5. OUTPUT POWER

ID:	39316	Date:	1/20/17
-----	-------	-------	---------

LIMITS

§15.247 (b) (1)

RSS-247 (5.4) (2)

The maximum antenna gain is less than 6 dBi, therefore the limit is 30 dBm.

TEST PROCEDURE

The transmitter output is connected to a wideband peak and average power meter.

RESULTS

Channel	Frequency (MHz)	Output Power (dBm)	Limit (dBm)	Margin (dB)
Low	2402	19.08	21	-1.92
Middle	2441	19.25	21	-1.75
High	2480	19.05	21	-1.95

8.4.6. AVERAGE POWER

ID:	39316	Date:	1/20/17
-----	-------	-------	---------

LIMITS

None; for reporting purposes only.

TEST PROCEDURE

The transmitter output is connected to a power meter.

RESULTS

The cable assembly insertion loss of 11 dB (including 10 dB pad and 1 dB cable) was entered as an offset in the power meter to allow for direct reading of power.

Channel	Frequency (MHz)	Average Power (dBm)
Low	2402	15.80
Middle	2441	15.85
High	2480	15.75

8.4.7. CONDUCTED BANDEDGE AND SPURIOUS EMISSIONS

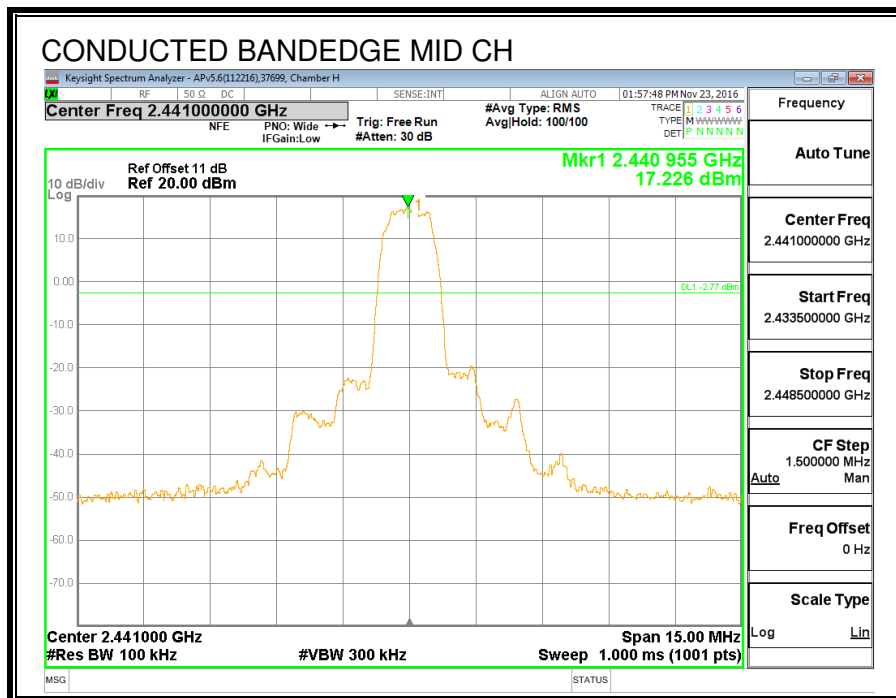
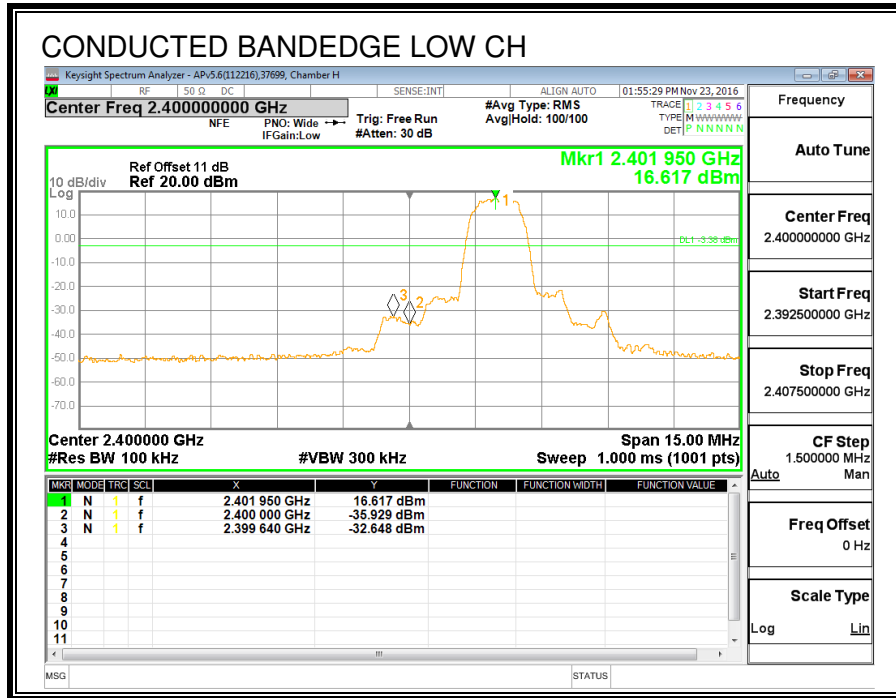

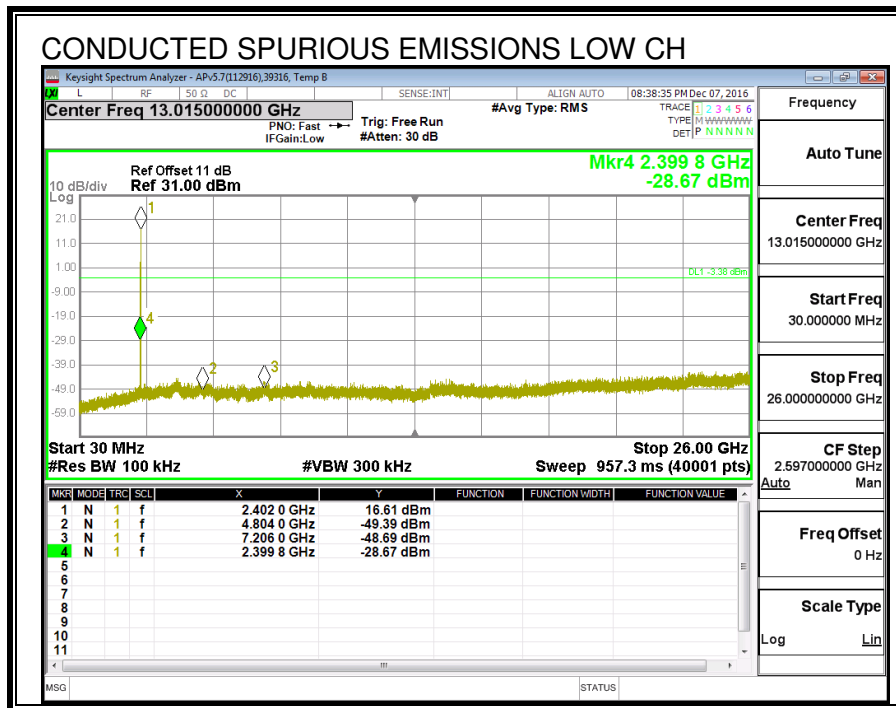
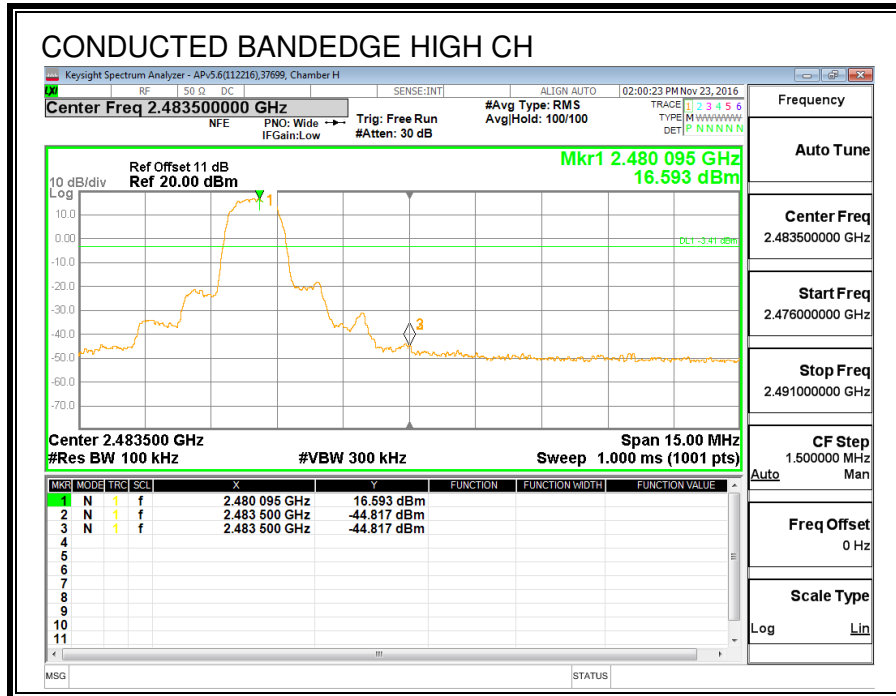

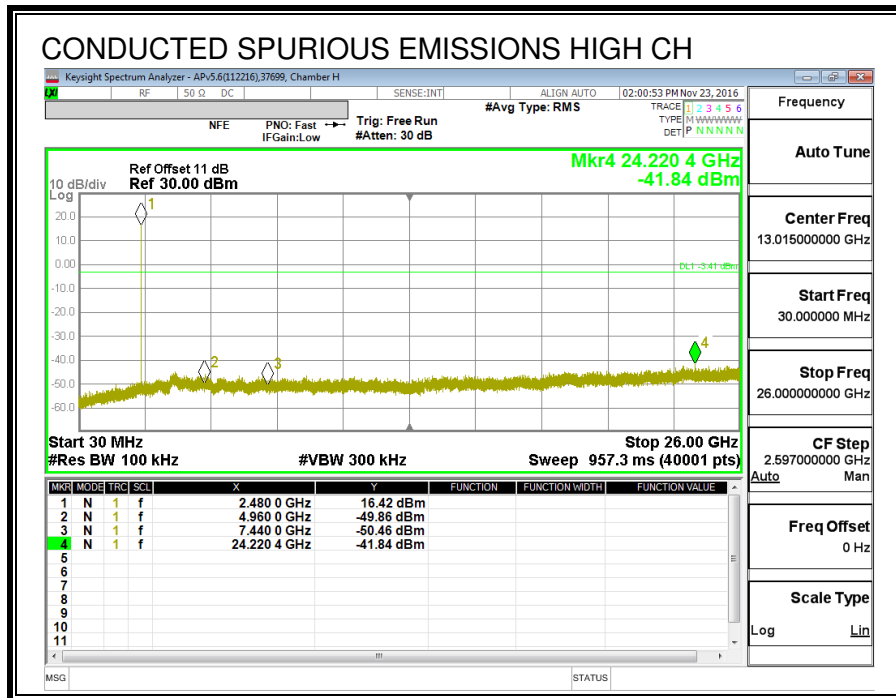
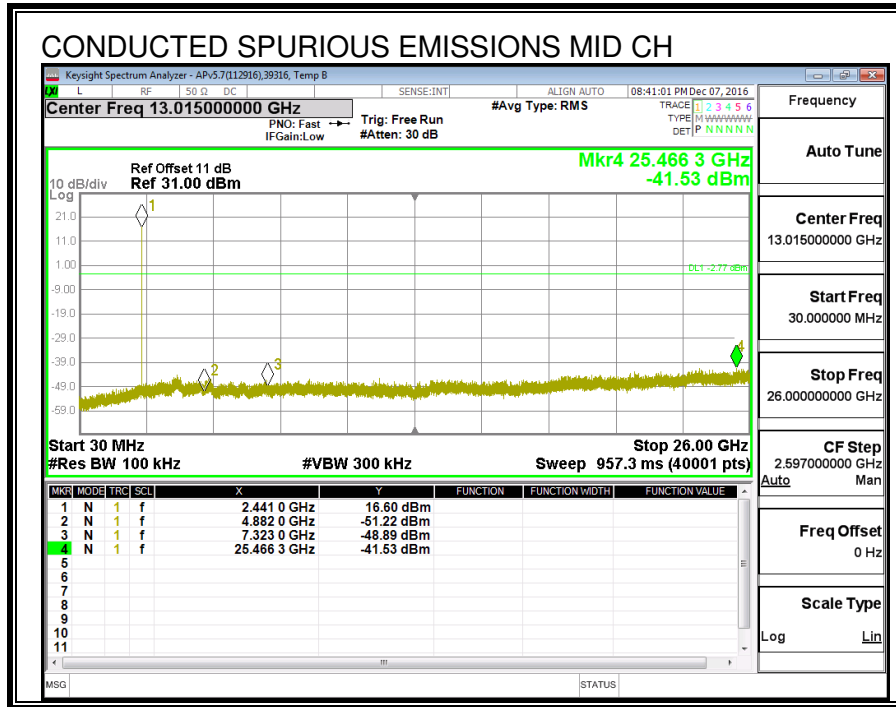

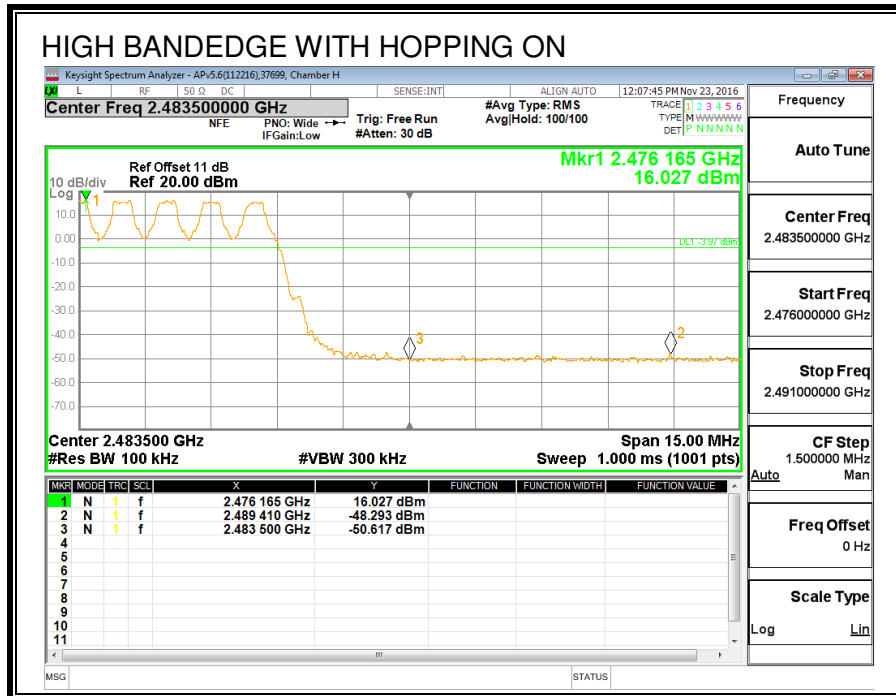
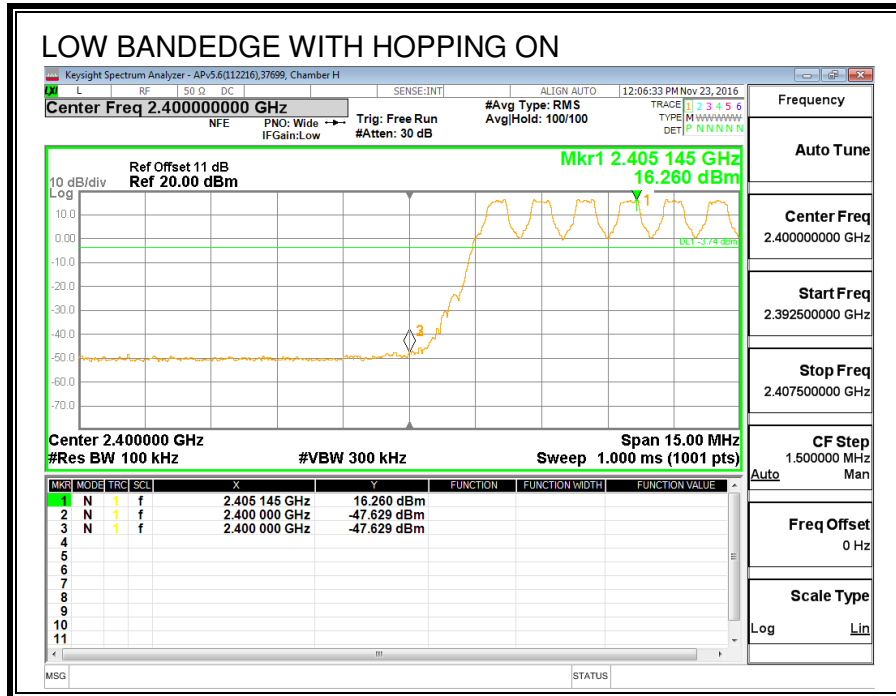

8.5. LOW POWER BASIC DATA RATE GFSK MODULATION

8.5.1. 20 dB AND 99% BANDWIDTH

LIMITS

None; for reporting purposes only.

TEST PROCEDURE

The transmitter output is connected to a spectrum analyzer. The RBW is set to $\geq 1\%$ of the 20 dB bandwidth. The VBW is set to \geq RBW. The sweep time is coupled.

RESULTS

Channel	Frequency (MHz)	20 dB Bandwidth (KHz)	99% Bandwidth (KHz)
Low	2402	941.1	909.92
Middle	2441	939.3	926.42
High	2480	951.2	913.06

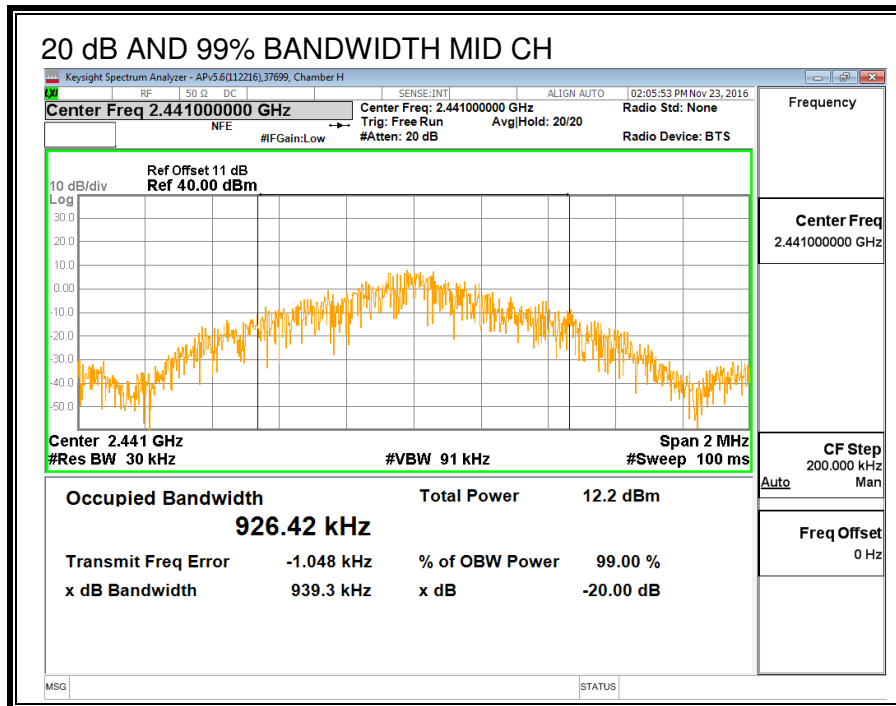
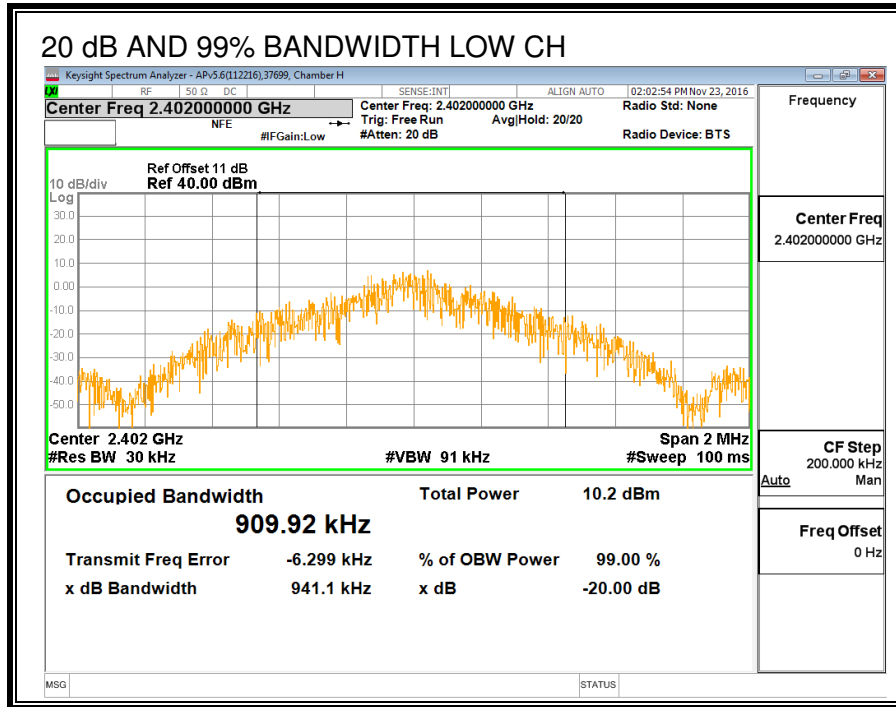

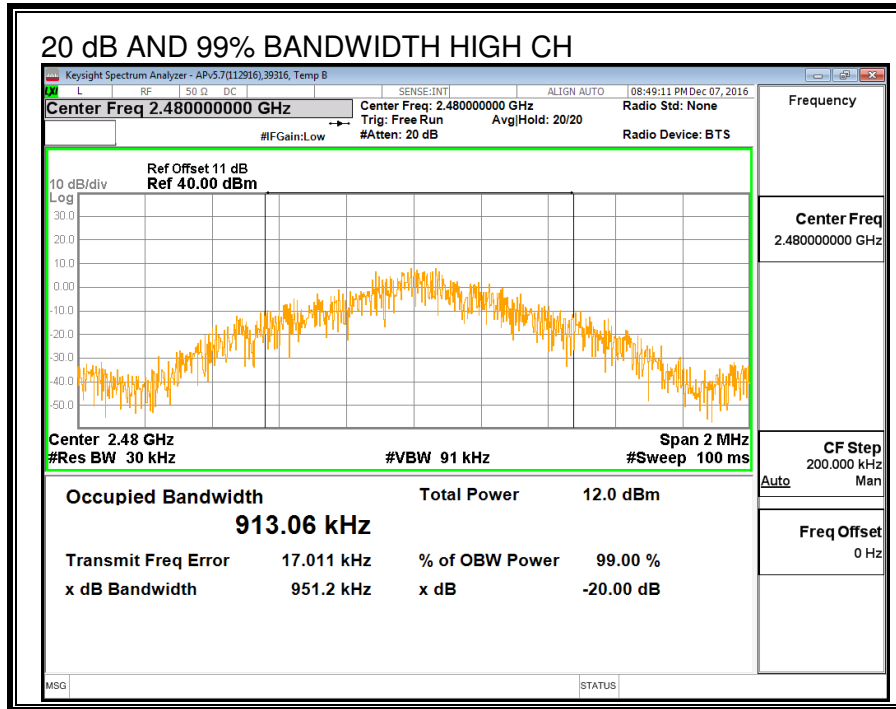

8.5.3. NUMBER OF HOPPING CHANNELS

LIMITS

FCC §15.247 (a) (1) (iii)

IC RSS-247 (5.1) (4)

Frequency hopping systems in the 2400 – 2483.5 MHz band shall use at least 15 non-overlapping channels.

TEST PROCEDURE

The transmitter output is connected to a spectrum analyzer. The span is set to cover the entire authorized band, in either a single sweep or in multiple contiguous sweeps. The RBW is set to a maximum of 1 % of the span. The analyzer is set to Max Hold.

RESULTS

Normal Mode: 79 Channels observed.

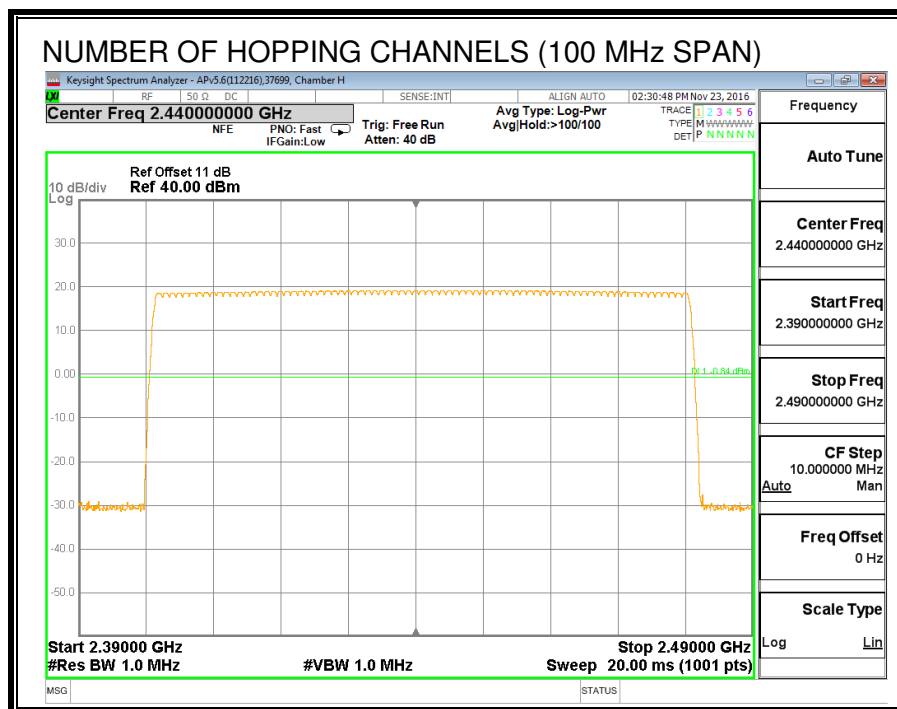

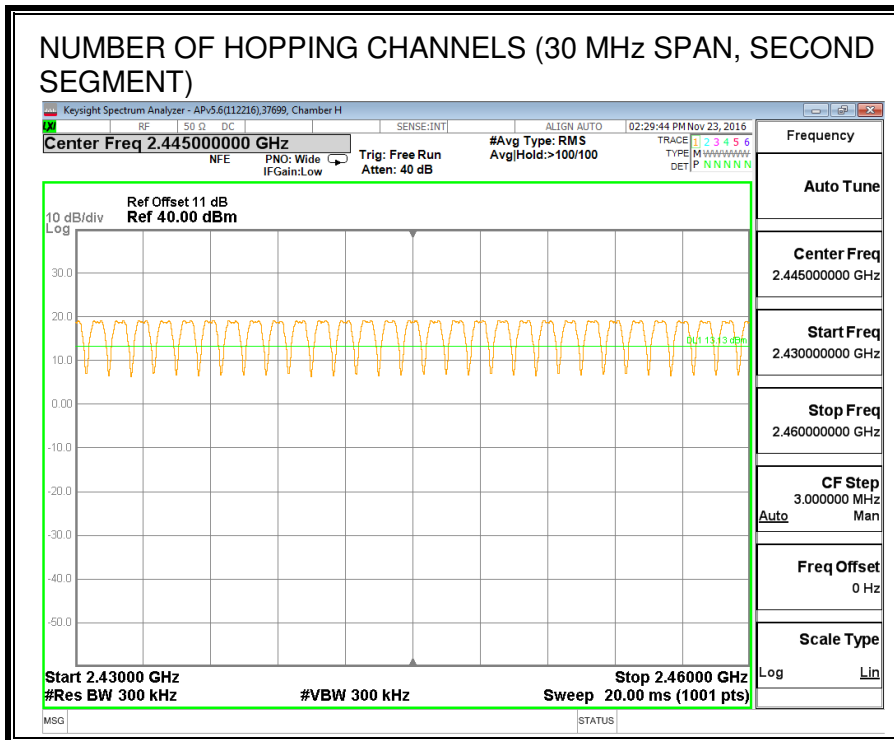
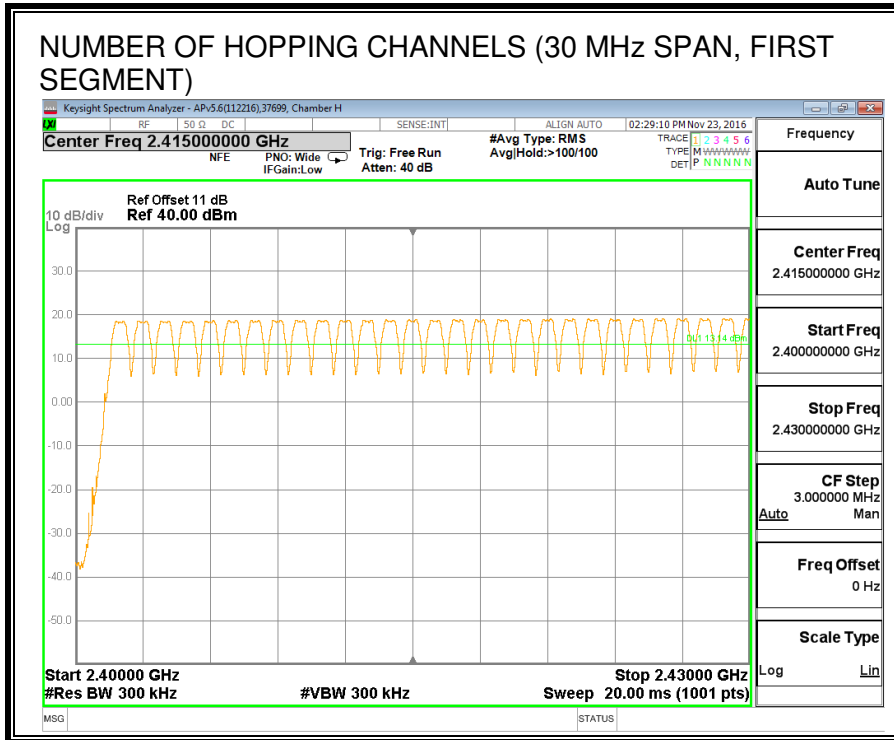

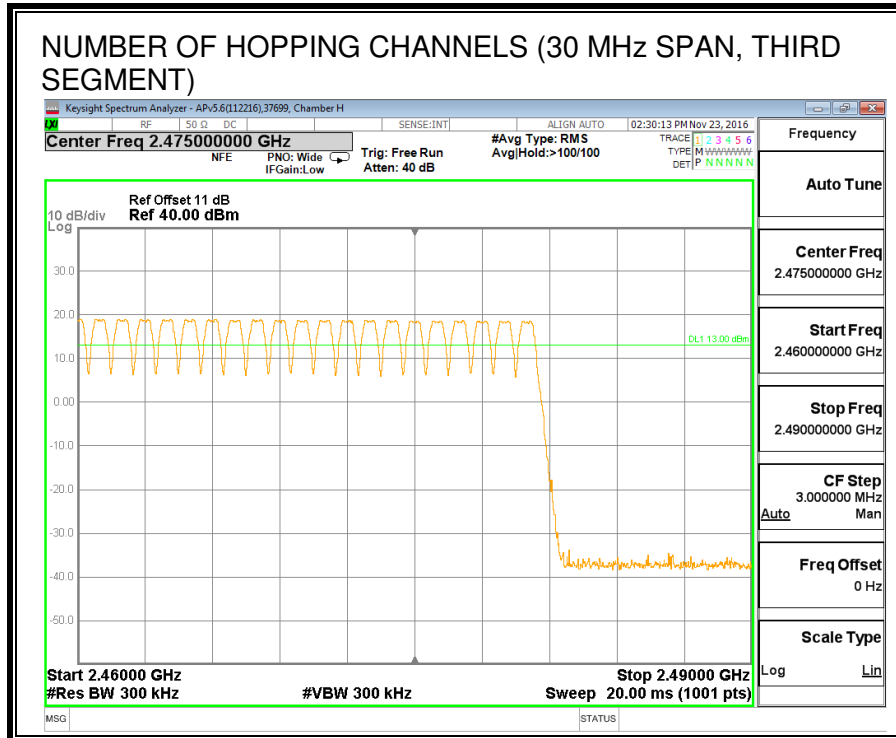

8.5.4. AVERAGE TIME OF OCCUPANCY

LIMITS

FCC §15.247 (a) (1) (iii)

IC RSS-247 (5.1) (4)

The average time of occupancy on any channel shall not be greater than 0.4 seconds within a period of 0.4 seconds multiplied by the number of hopping channels employed.

TEST PROCEDURE

The transmitter output is connected to a spectrum analyzer. The span is set to 0 Hz, centered on a single, selected hopping channel. The width of a single pulse is measured in a fast scan. The number of pulses is measured in a 3.16 second scan, to enable resolution of each occurrence.

The average time of occupancy in the specified 31.6 second period (79 channels * 0.4 s) is equal to $10 * (\# \text{ of pulses in } 3.16 \text{ s}) * \text{ pulse width}$.

For AFH mode, the average time of occupancy in the specified 8 second period (20 channels * 0.4 seconds) is equal to $10 * (\# \text{ of pulses in } 0.8 \text{ s}) * \text{ pulse width}$.

RESULTS

DH Packet	Pulse Width (msec)	Number of Pulses in 3.16 seconds	Average Time of Occupancy (sec)	Limit (sec)	Margin (sec)
GFSK Normal Mode					
DH1	0.384	31	0.119	0.4	-0.281
DH3	1.64	16	0.262	0.4	-0.138
DH5	2.888	12	0.347	0.4	-0.053
DH Packet	Pulse Width (msec)	Number of Pulses in 0.8 seconds	Average Time of Occupancy (sec)	Limit (sec)	Margin (sec)
GFSK AFH Mode					
DH1	0.384	7.75	0.030	0.4	-0.370
DH3	1.64	4	0.066	0.4	-0.334
DH5	2.888	3	0.087	0.4	-0.313

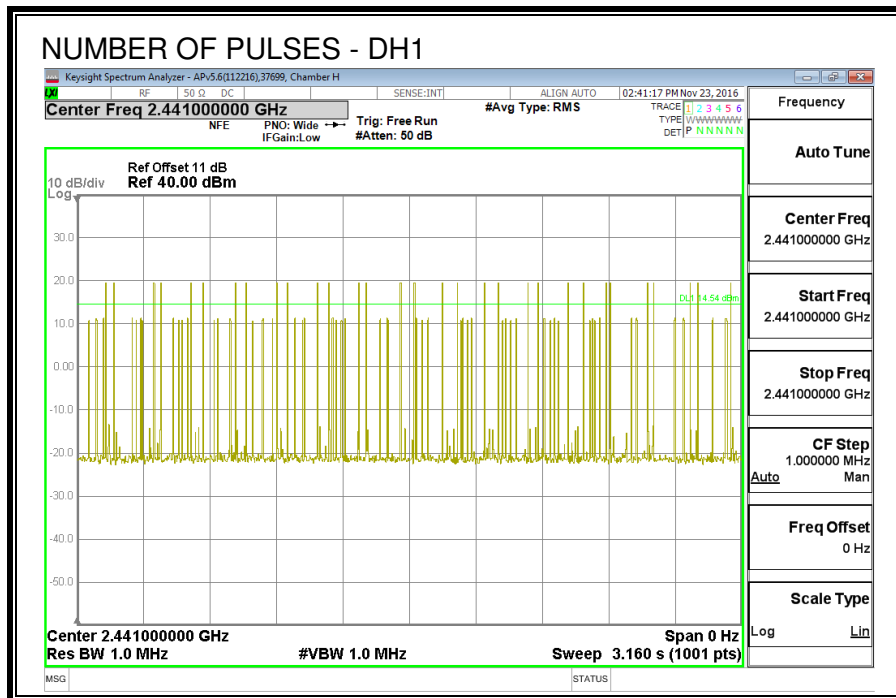
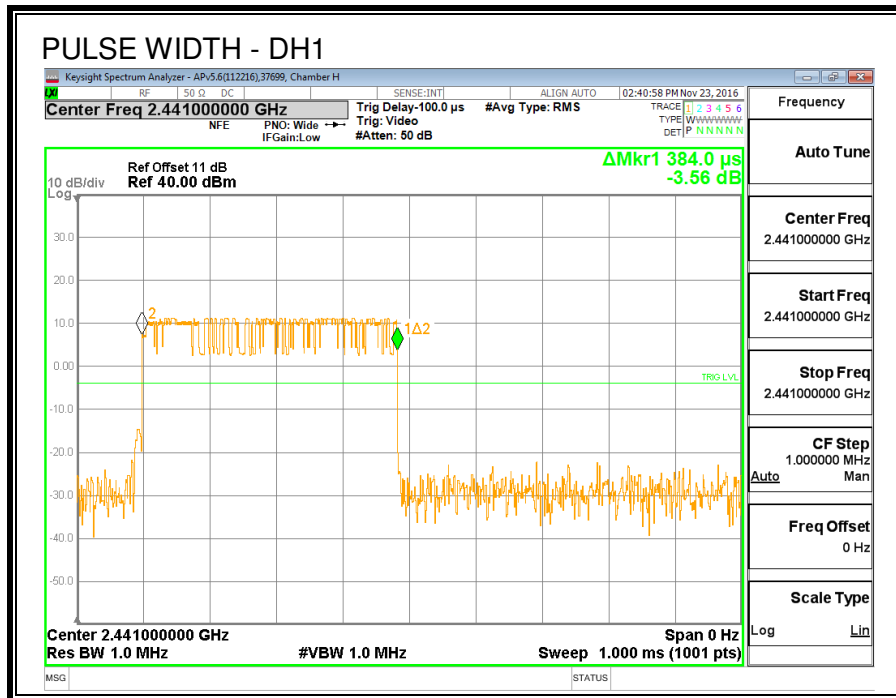

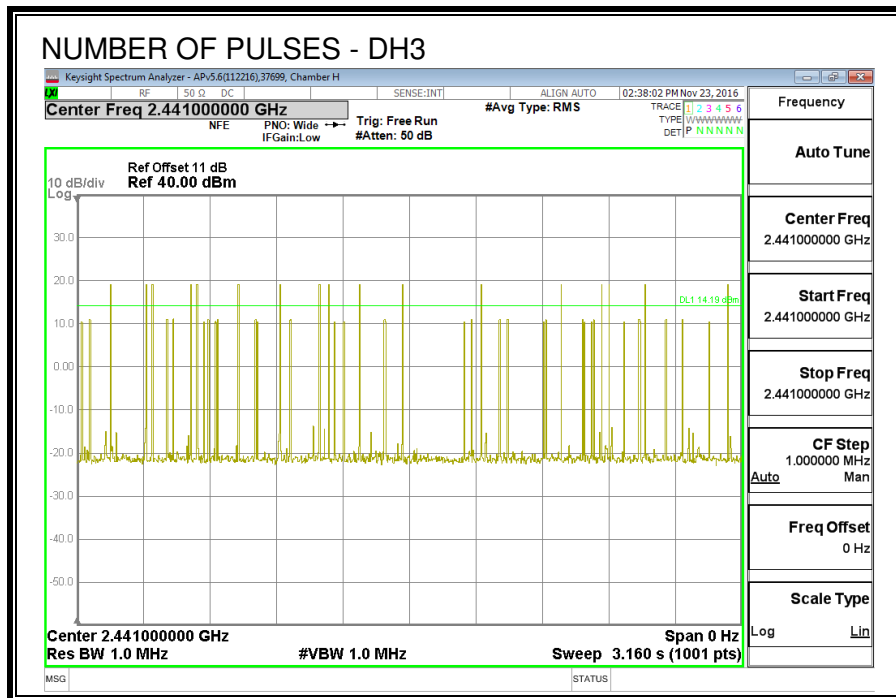
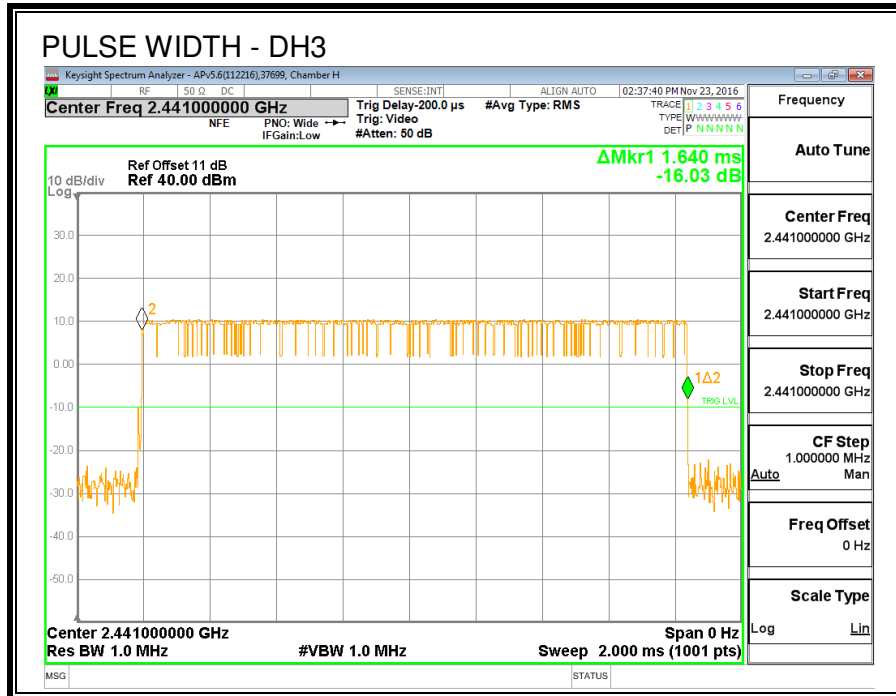

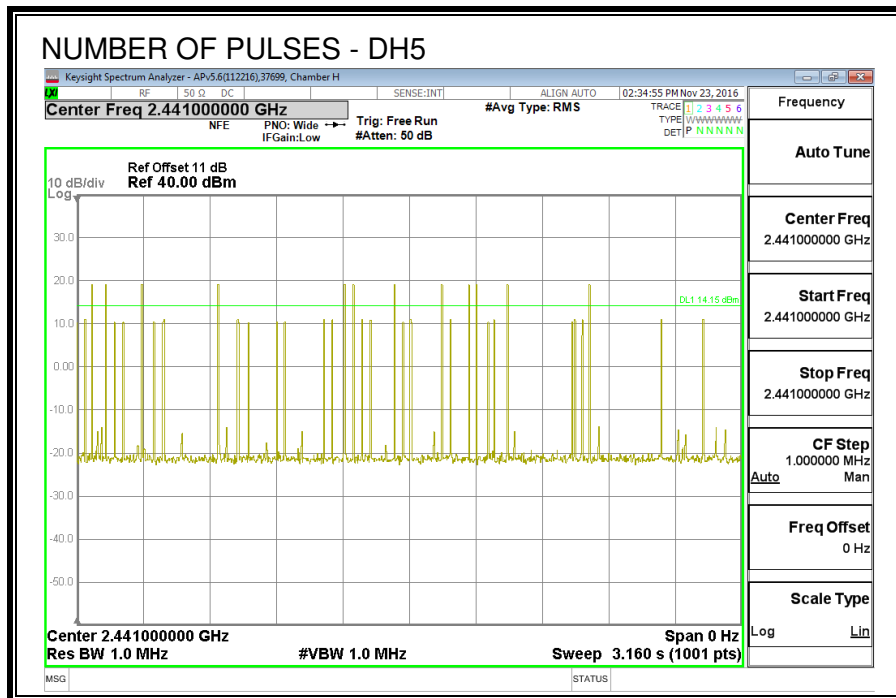
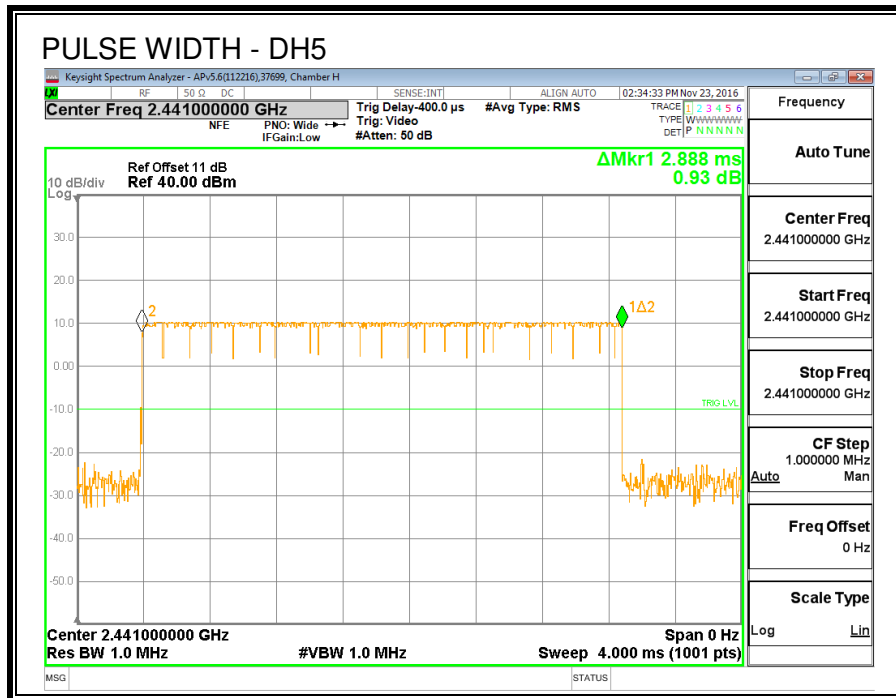

8.5.5. OUTPUT POWER

ID:	39316	Date:	1/20/17
-----	-------	-------	---------

LIMITS

§15.247 (b) (1)

RSS-247 (5.4) (2)

The maximum antenna gain is less than 6 dBi, therefore the limit is 30 dBm.

TEST PROCEDURE

The transmitter output is connected to a wideband peak and average power meter.

RESULTS

Channel	Frequency (MHz)	Output Power (dBm)	Limit (dBm)	Margin (dB)
Low	2402	10.46	21	-10.54
Middle	2441	10.74	21	-10.26
High	2480	10.70	21	-10.30

8.5.6. AVERAGE POWER

ID:	39316	Date:	1/20/17
-----	-------	-------	---------

LIMITS

None; for reporting purposes only.

TEST PROCEDURE

The transmitter output is connected to a power meter.

RESULTS

The cable assembly insertion loss of 11 dB (including 10 dB pad and 1 dB cable) was entered as an offset in the power meter to allow for direct reading of power.

Channel	Frequency (MHz)	Average Power (dBm)
Low	2402	10.28
Middle	2441	10.31
High	2480	10.49

8.5.7. CONDUCTED BANDEDGE AND SPURIOUS EMISSIONS

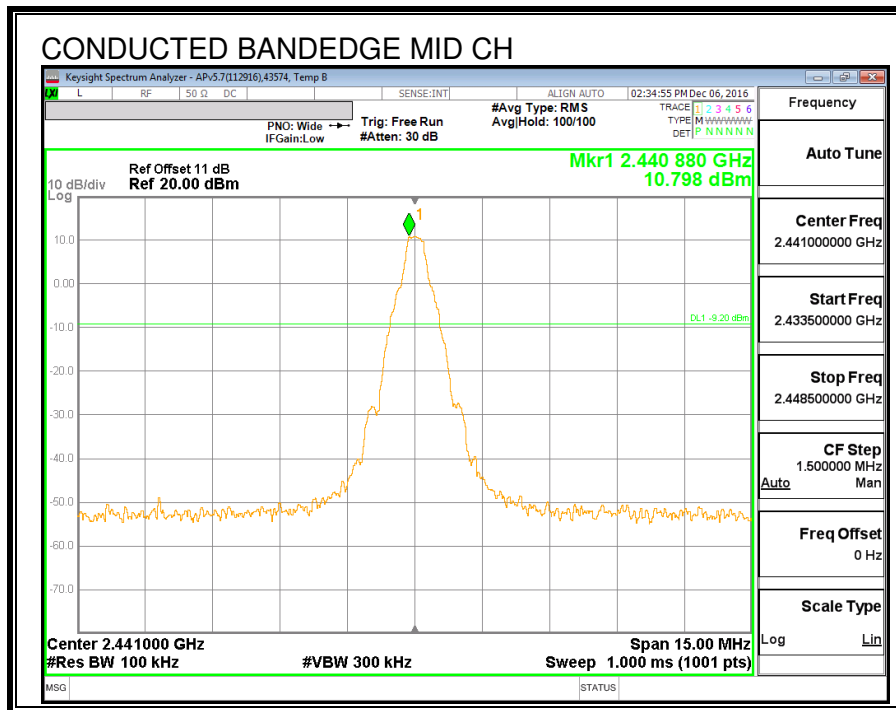
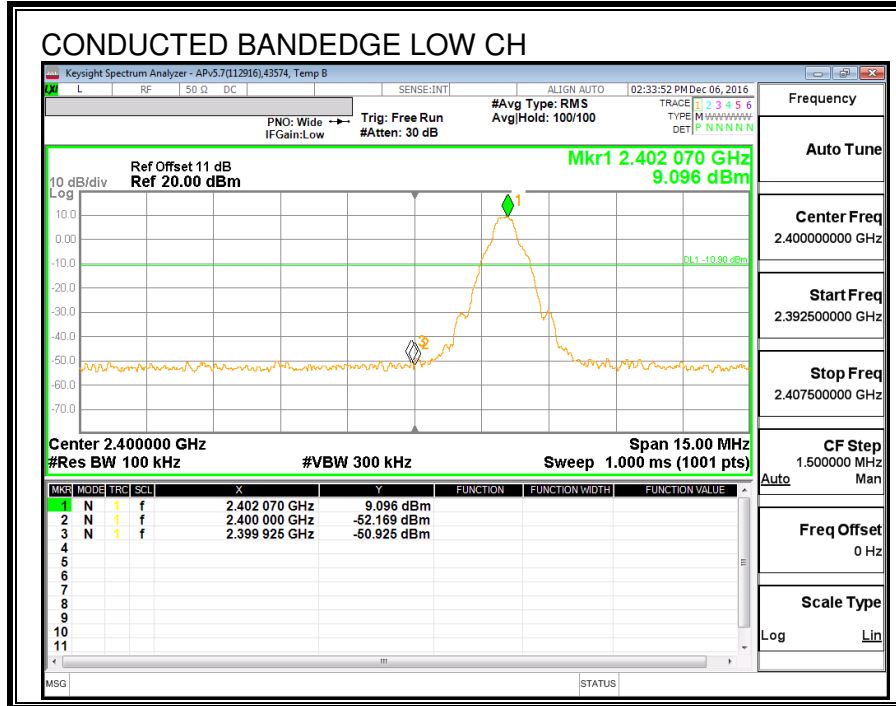

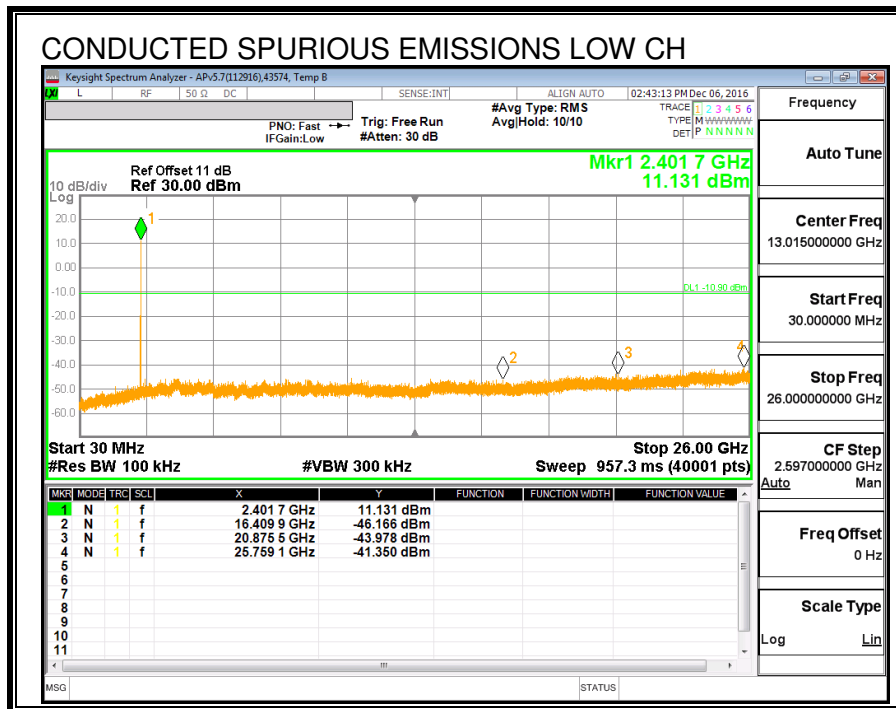
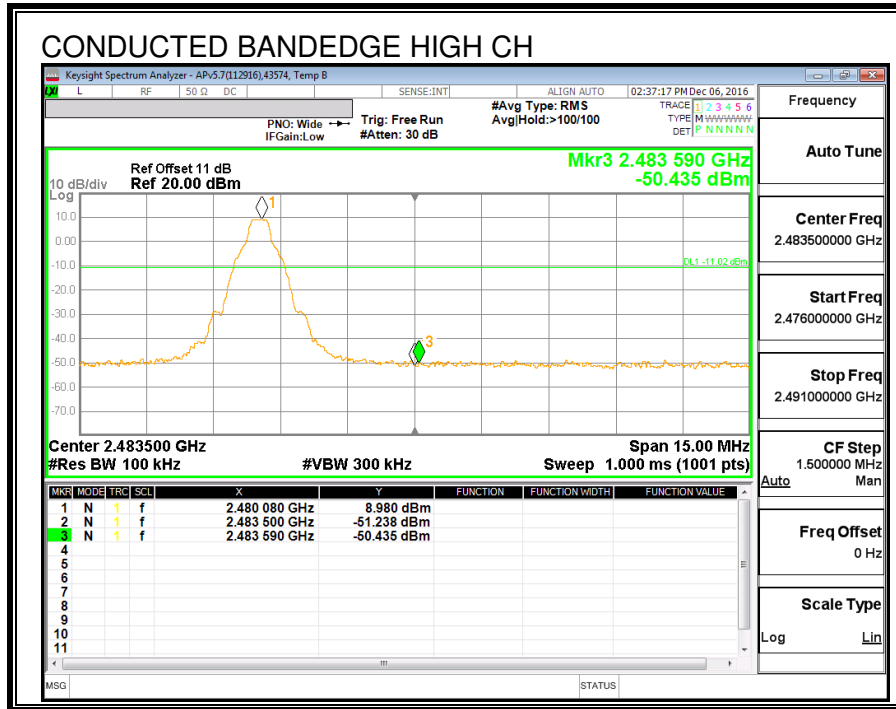

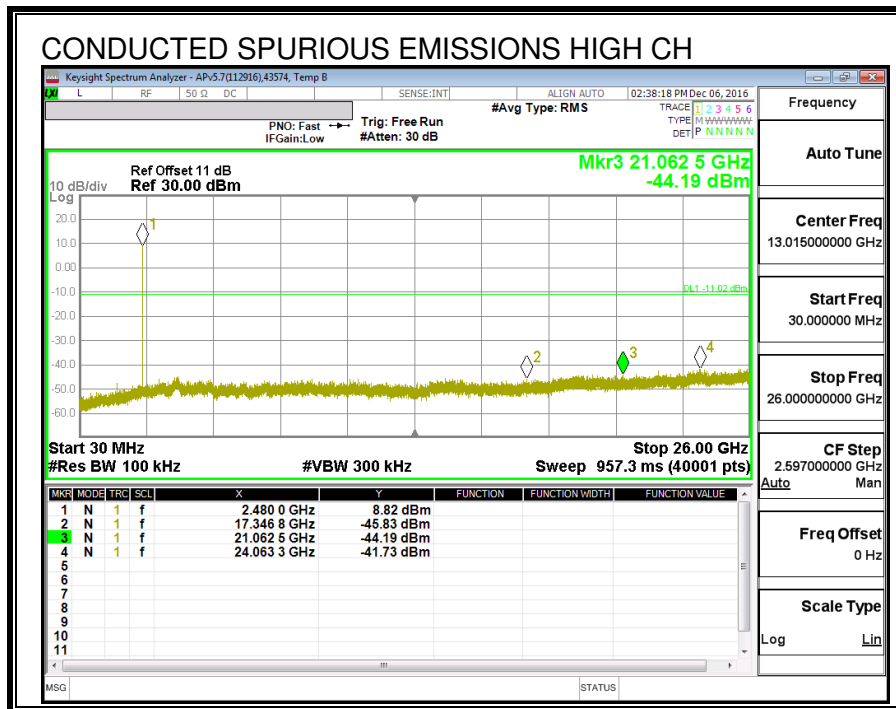
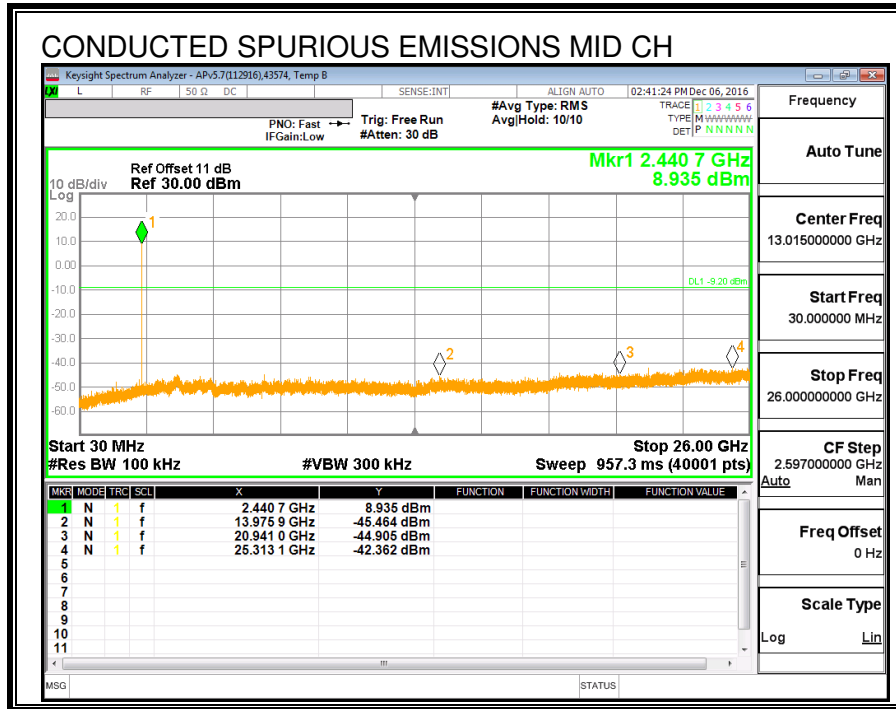

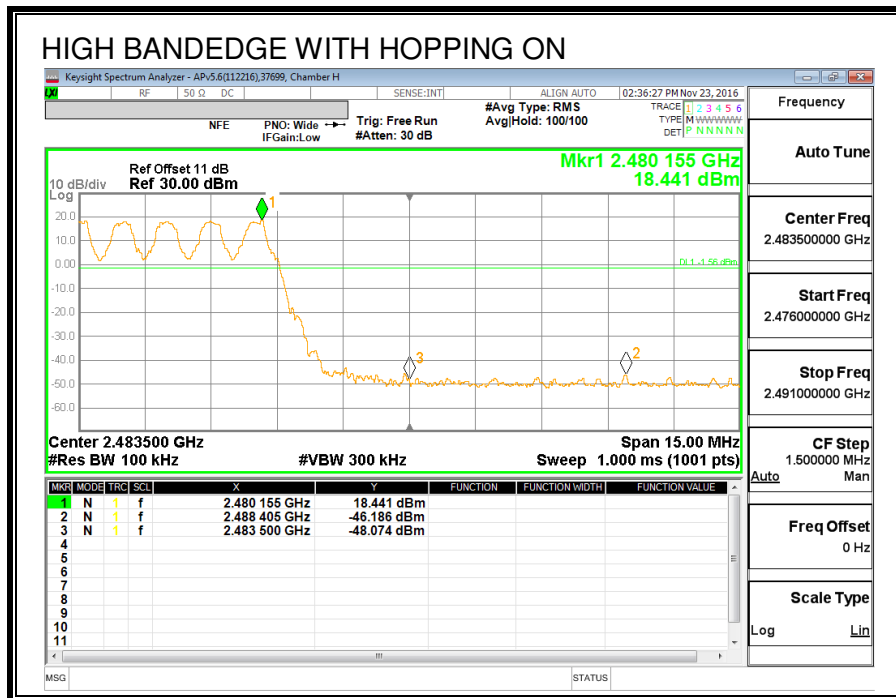
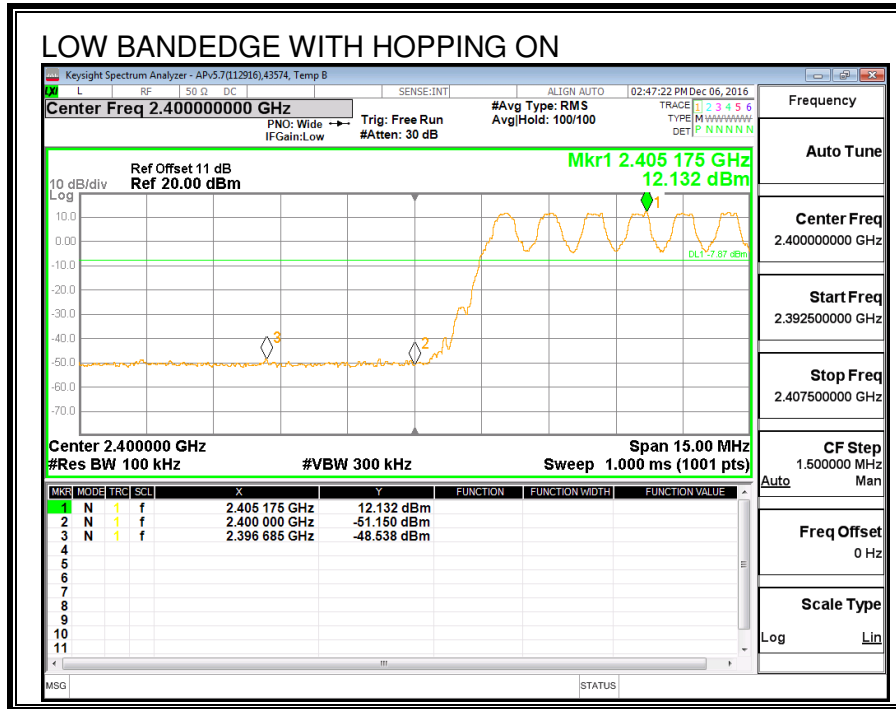

8.6. LOW POWER ENHANCED DATA RATE DQPSK MODULATION

8.6.1. OUTPUT POWER

ID:	39316	Date:	1/20/17
-----	-------	-------	---------

LIMITS

§15.247 (b) (1)

RSS-247 (5.4) (2)

The maximum antenna gain is less than 6 dBi, therefore the limit is 30 dBm.

TEST PROCEDURE

The transmitter output is connected to a wideband peak and average power meter.

RESULTS

Channel	Frequency (MHz)	Output Power (dBm)	Limit (dBm)	Margin (dB)
Low	2402	11.25	21	-9.75
Middle	2441	11.50	21	-9.50
High	2480	11.23	21	-9.77

8.6.2. AVERAGE POWER

ID:	39316	Date:	1/20/17
-----	-------	-------	---------

LIMITS

None; for reporting purposes only.

TEST PROCEDURE

The transmitter output is connected to a power meter.

RESULTS

The cable assembly insertion loss of 11 dB (including 10 dB pad and 1 dB cable) was entered as an offset in the power meter to allow for direct reading of power.

Channel	Frequency (MHz)	Average Power (dBm)
Low	2402	8.45
Middle	2441	8.88
High	2480	8.54

8.7. LOW POWER ENHANCED DATA RATE 8PSK MODULATION

8.7.1. 20 dB AND 99% BANDWIDTH

LIMITS

None; for reporting purposes only.

TEST PROCEDURE

The transmitter output is connected to a spectrum analyzer. The RBW is set to $\geq 1\%$ of the 20 dB bandwidth. The VBW is set to \geq RBW. The sweep time is coupled.

RESULTS

Channel	Frequency (MHz)	20 dB Bandwidth (KHz)	99% Bandwidth (KHz)
Low	2402	1363	1268.9
Middle	2441	1345	1289.6
High	2480	1392	1282.5

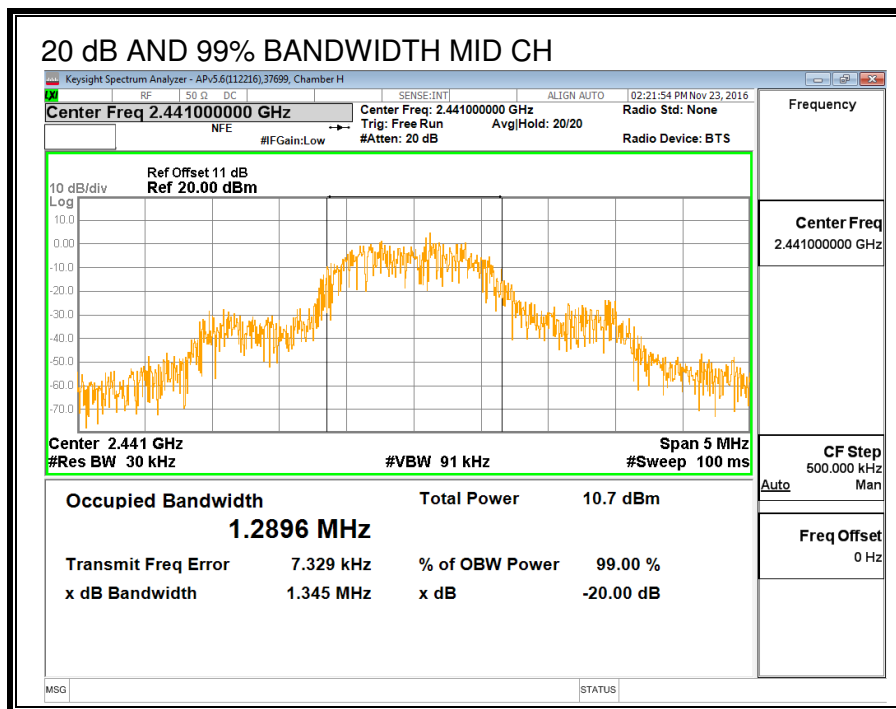
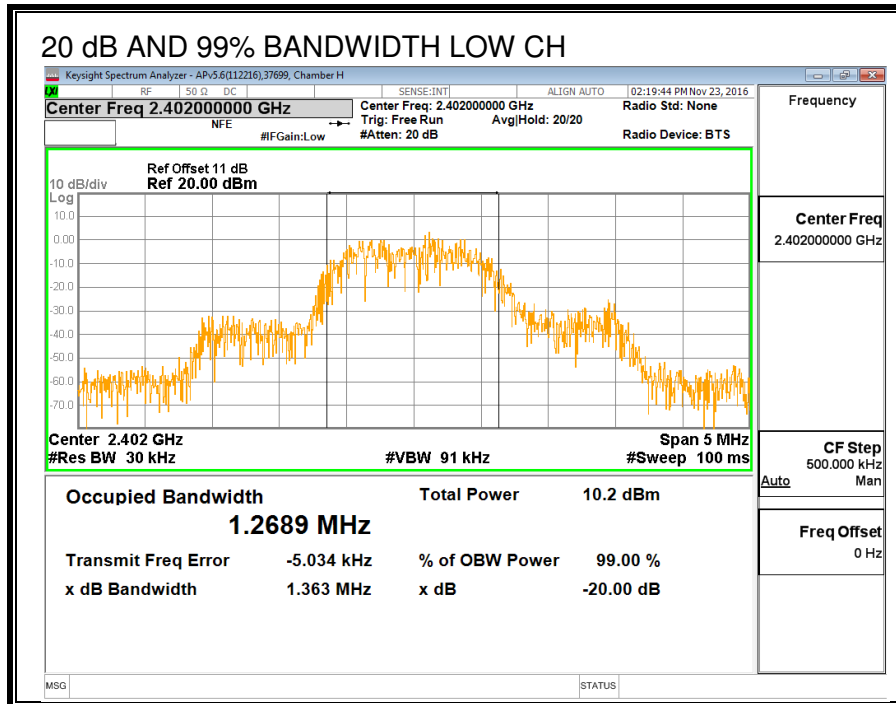

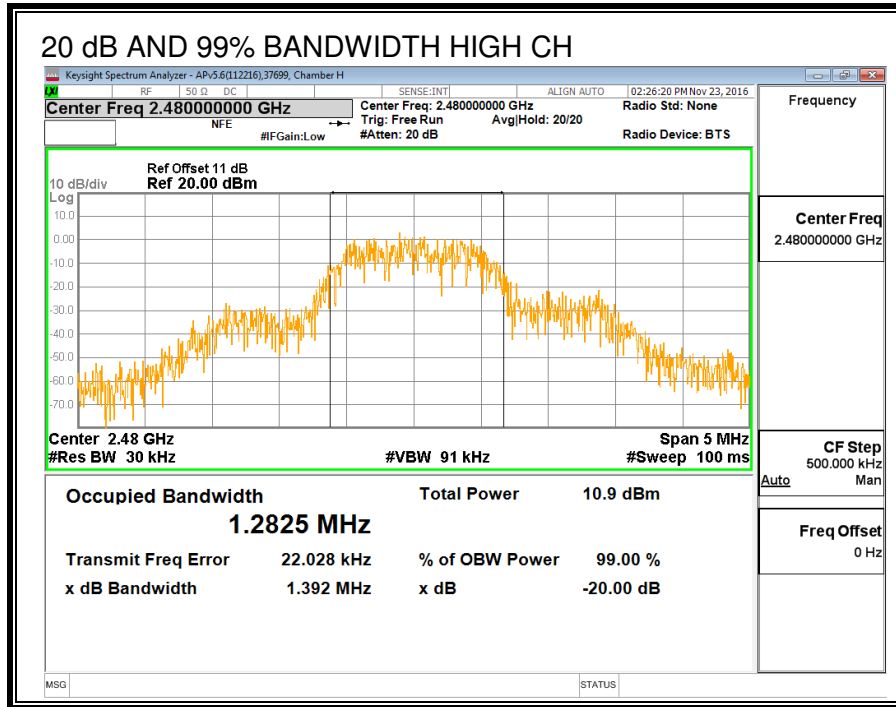

8.7.2. HOPPING FREQUENCY SEPARATION

LIMITS

FCC §15.247 (a) (1)

IC RSS-247 (5.1) (2)

Frequency hopping systems shall have hopping channel carrier frequencies separated by a minimum of 25 kHz or the 20 dB bandwidth of the hopping channel, whichever is greater.

Alternatively, frequency hopping systems operating in the 2400-2483.5 MHz band may have hopping channel carrier frequencies that are separated by 25 kHz or two-thirds of the 20 dB bandwidth of the hopping channel, whichever is greater, provided the systems operate with an output power no greater than 125 mW.

TEST PROCEDURE

The transmitter output is connected to a spectrum analyzer. The RBW is set to 300 kHz and the VBW is set to 910 kHz. The sweep time is coupled.

RESULTS

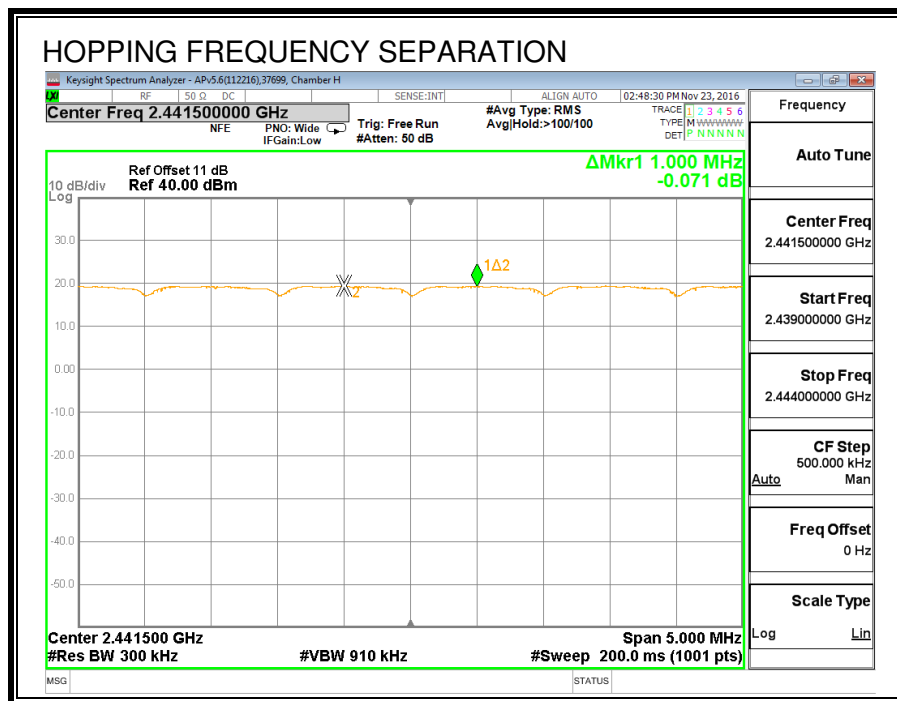

8.7.3. NUMBER OF HOPPING CHANNELS

LIMITS

FCC §15.247 (a) (1) (iii)

IC RSS-247 (5.1) (4)

Frequency hopping systems in the 2400 – 2483.5 MHz band shall use at least 15 non-overlapping channels.

TEST PROCEDURE

The transmitter output is connected to a spectrum analyzer. The span is set to cover the entire authorized band, in either a single sweep or in multiple contiguous sweeps. The RBW is set to a maximum of 1 % of the span. The analyzer is set to Max Hold.

RESULTS

Normal Mode: 79 Channels observed.

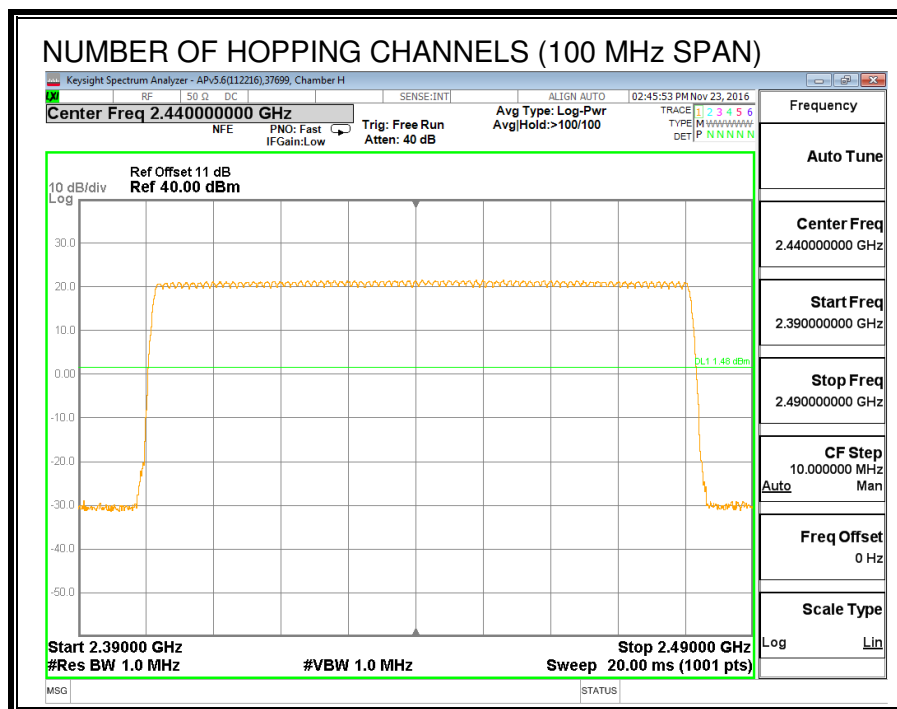

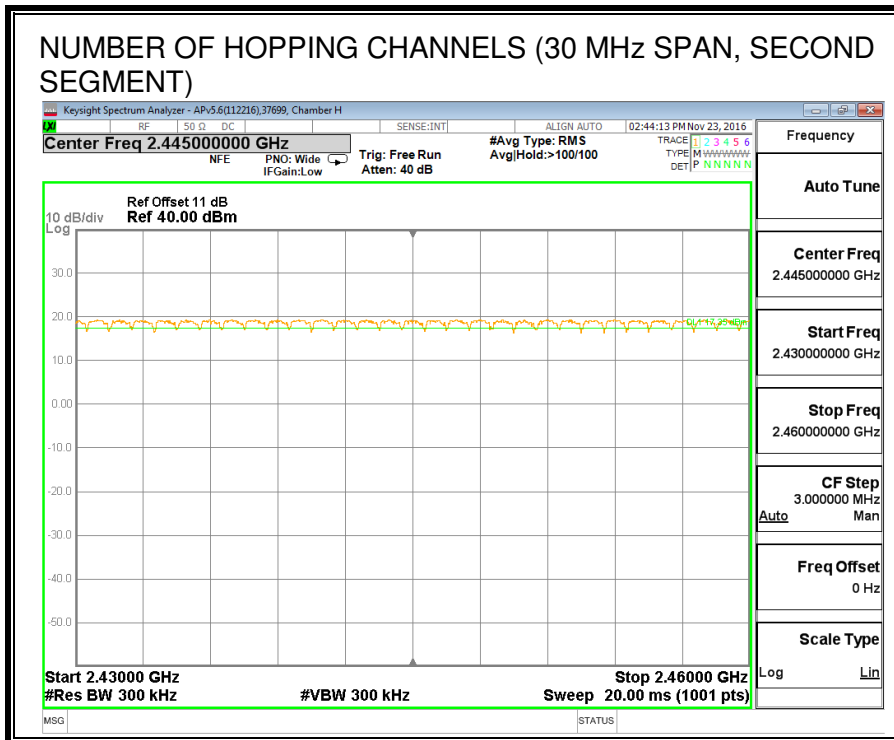
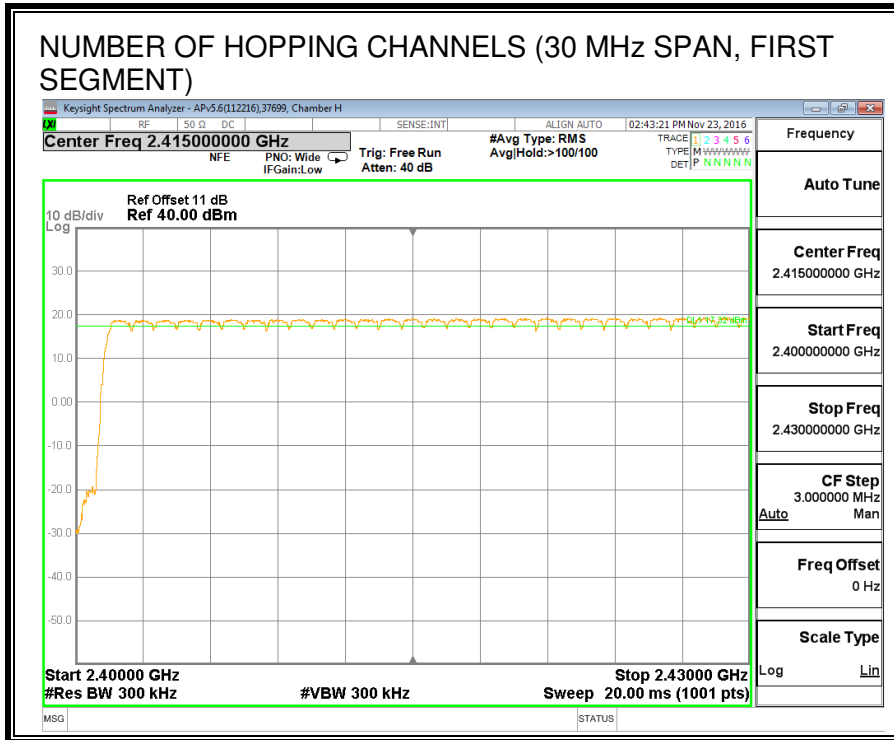

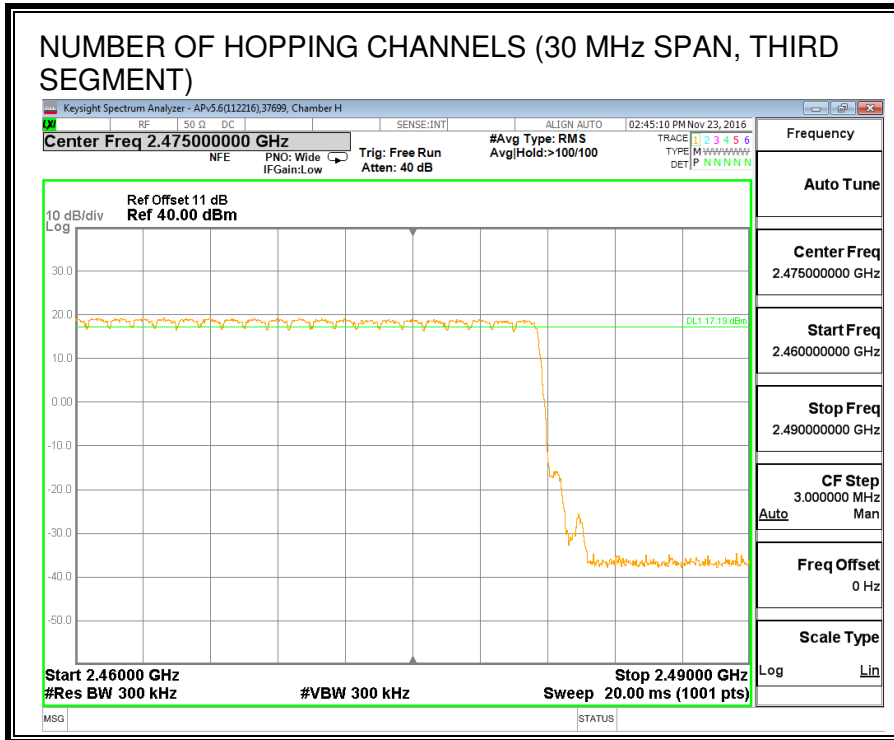

8.7.4. AVERAGE TIME OF OCCUPANCY

LIMITS

FCC §15.247 (a) (1) (iii)

IC RSS-247 (5.1) (4)

The average time of occupancy on any channel shall not be greater than 0.4 seconds within a period of 0.4 seconds multiplied by the number of hopping channels employed.

TEST PROCEDURE

The transmitter output is connected to a spectrum analyzer. The span is set to 0 Hz, centered on a single, selected hopping channel. The width of a single pulse is measured in a fast scan. The number of pulses is measured in a 3.16 second scan, to enable resolution of each occurrence.

The average time of occupancy in the specified 31.6 second period (79 channels * 0.4 s) is equal to $10 * (\# \text{ of pulses in } 3.16 \text{ s}) * \text{ pulse width}$.

For AFH mode, the average time of occupancy in the specified 8 second period (20 channels * 0.4 seconds) is equal to $10 * (\# \text{ of pulses in } 0.8 \text{ s}) * \text{ pulse width}$.

RESULTS

DH Packet	Pulse Width (msec)	Number of Pulses in 3.16 seconds	Average Time of Occupancy (sec)	Limit (sec)	Margin (sec)
8PSK Normal Mode					
3DH1	0.391	32	0.125	0.4	-0.275
3DH3	1.642	18	0.296	0.4	-0.104
3DH5	2.892	10	0.289	0.4	-0.111

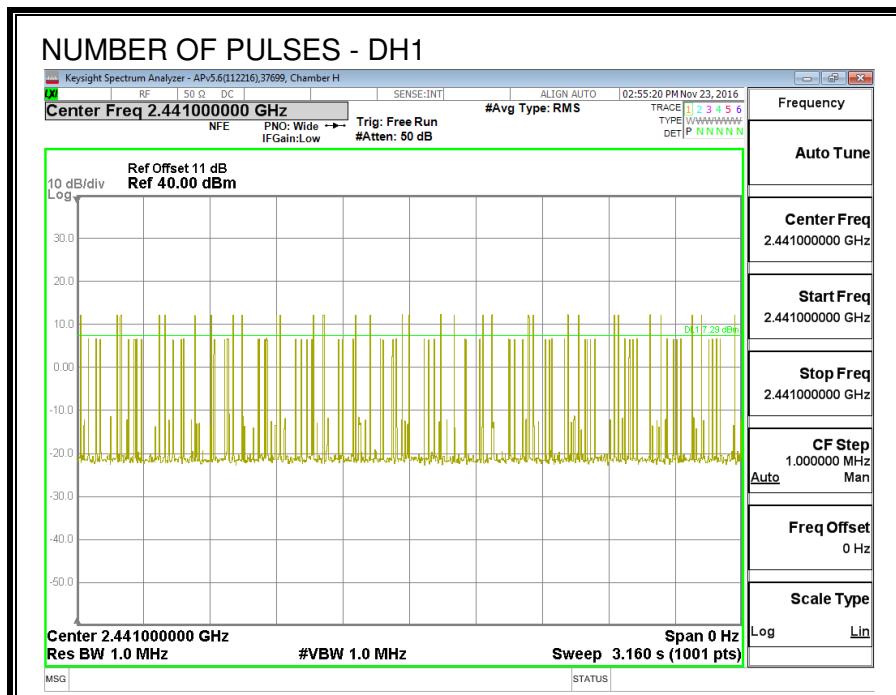

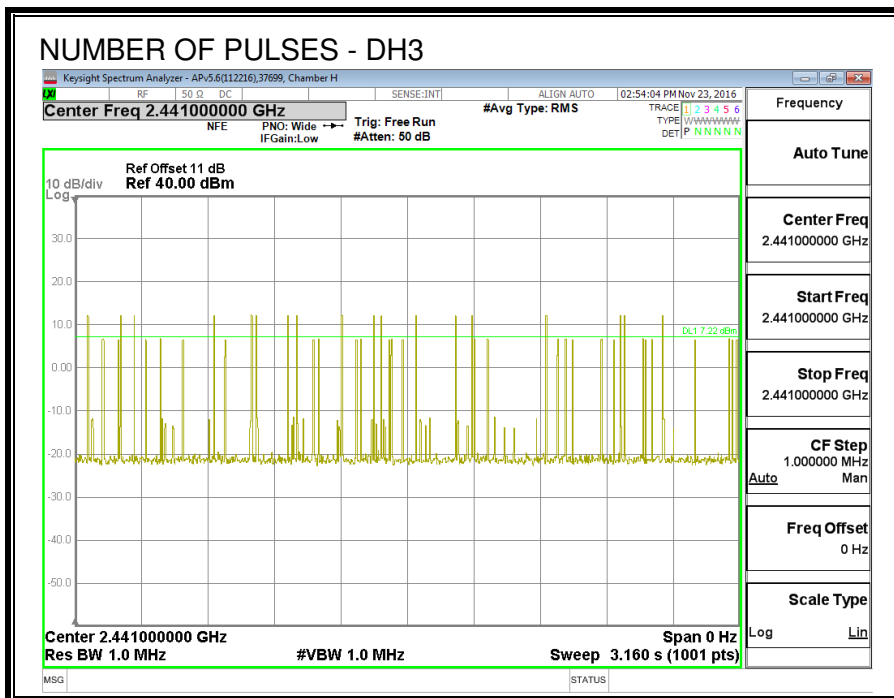

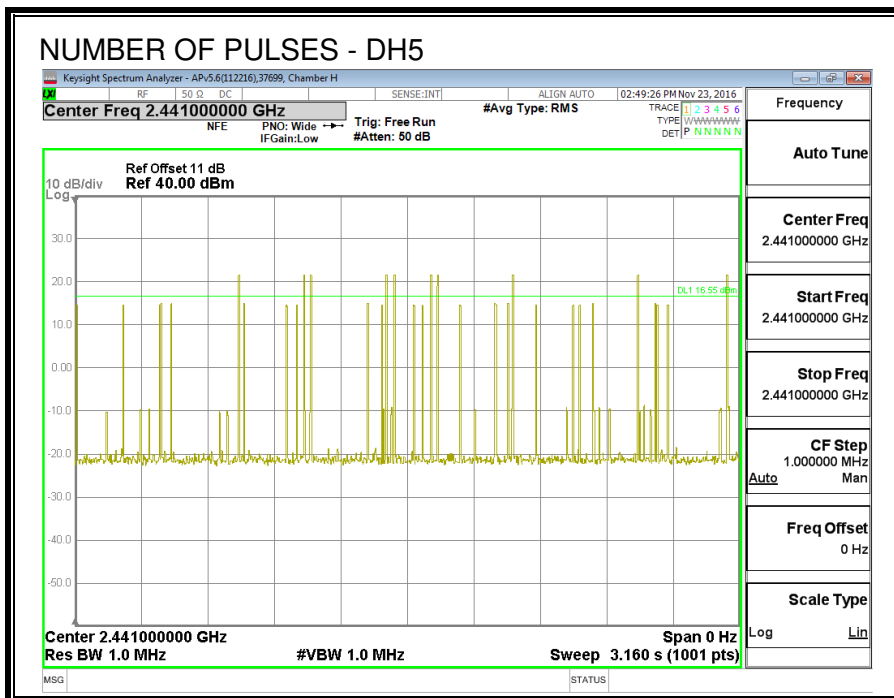
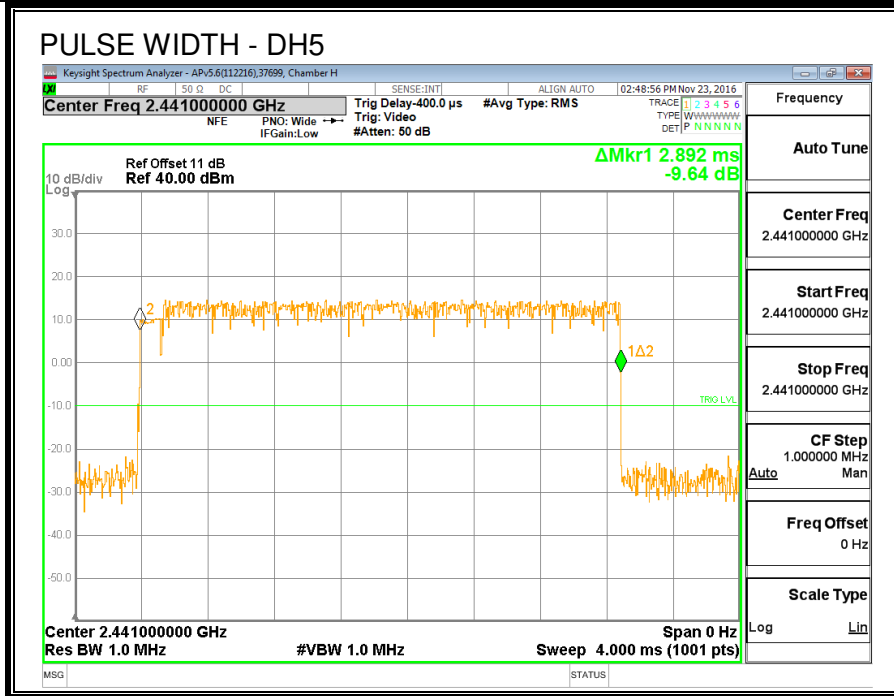

8.7.5. OUTPUT POWER

ID:	39316	Date:	1/20/17
-----	-------	-------	---------

LIMITS

§15.247 (b) (1)

RSS-247 (5.4) (2)

The maximum antenna gain is less than 6 dBi, therefore the limit is 30 dBm.

TEST PROCEDURE

The transmitter output is connected to a wideband peak and average power meter.

RESULTS

Channel	Frequency (MHz)	Output Power (dBm)	Limit (dBm)	Margin (dB)
Low	2402	11.38	21	-9.6
Middle	2441	11.58	21	-9.2
High	2480	11.30	21	-9.7

8.7.6. AVERAGE POWER

ID:	39316	Date:	1/20/17
-----	-------	-------	---------

LIMITS

None; for reporting purposes only.

TEST PROCEDURE

The transmitter output is connected to a power meter.

RESULTS

The cable assembly insertion loss of 11 dB (including 10 dB pad and 1 dB cable) was entered as an offset in the power meter to allow for direct reading of power.

Channel	Frequency (MHz)	Average Power (dBm)
Low	2402	8.57
Middle	2441	8.97
High	2480	8.64

8.7.7. CONDUCTED BANDEDGE AND SPURIOUS EMISSIONS

