



**FCC 47 CFR PART 15 SUBPART C
INDUSTRY CANADA RSS-247 ISSUE 1**

**BLUETOOTH LOW ENERGY
CERTIFICATION TEST REPORT**

FOR

TABLET DEVICE

MODEL NUMBER: A1584

**FCC ID: BCGA1584
IC: 579C-A1584**

REPORT NUMBER: 14U19185-E2V3

ISSUE DATE: SEPTEMBER 11, 2015

Prepared for
**APPLE, INC.
1 INFINITE LOOP
CUPERTINO, CA 95014, U.S.A.**

Prepared by
**UL VERIFICATION SERVICES INC.
47173 BENICIA STREET
FREMONT, CA 94538, U.S.A.
TEL: (510) 771-1000
FAX: (510) 661-0888**



NVLAP LAB CODE 200065-0

Revision History

<u>Rev.</u>	<u>Issue Date</u>	<u>Revisions</u>	<u>Revised By</u>
V1	09/03/2015	Initial Issue	M. Mekuria
V2	09/08/2015	Addressed TCB Questions	E. Yu
V3	09/11/2015	Updated antenna gain	C. Pang

TABLE OF CONTENTS

1. ATTESTATION OF TEST RESULTS	5
2. TEST METHODOLOGY	6
3. FACILITIES AND ACCREDITATION	6
4. CALIBRATION AND UNCERTAINTY	7
4.1. MEASURING INSTRUMENT CALIBRATION	7
4.2. SAMPLE CALCULATION	7
4.3. MEASUREMENT UNCERTAINTY.....	7
5. EQUIPMENT UNDER TEST	8
5.1. DESCRIPTION OF EUT	8
5.2. MAXIMUM OUTPUT POWER.....	8
5.3. DESCRIPTION OF AVAILABLE ANTENNAS	8
5.4. SOFTWARE AND FIRMWARE.....	8
5.5. WORST-CASE CONFIGURATION AND MODE.....	9
5.6. DESCRIPTION OF TEST SETUP.....	10
6. TEST AND MEASUREMENT EQUIPMENT	17
7. ANTENNA PORT TEST RESULTS	18
7.1. MEASUREMENT METHODS	18
7.2. ON TIME, DUTY CYCLE	19
7.3. 6 dB BANDWIDTH.....	21
7.4. 99% BANDWIDTH.....	24
7.5. AVERAGE POWER.....	27
7.6. OUTPUT POWER.....	28
7.7. POWER SPECTRAL DENSITY	29
7.8. CONDUCTED SPURIOUS EMISSIONS.....	32
8. RADIATED TEST RESULTS.....	36
8.1. LIMITS AND PROCEDURE	36
8.2. TRANSMITTER ABOVE 1 GHz.....	37
8.2.1. RESTRICTED BANDEDGE	37
8.2.2. HARMONICS AND SPURIOUS EMISSIONS	41
8.3. WORST CASE CO-LOCATION	47
8.4. WORST-CASE BELOW 1 GHz.....	49
8.5. WORST-CASE 18 to 26 GHz.....	51
9. AC POWER LINE CONDUCTED EMISSIONS	53

9.1.	<i>EUT POWERED BY AC/DC ADAPTER VIA USB CABLE</i>	54
9.2.	<i>EUT POWERED BY HOST PC VIA USB CABLE</i>	56
10.	SETUP PHOTOS	58

1. ATTESTATION OF TEST RESULTS

COMPANY NAME: APPLE, INC.
1 INFINITE LOOP
CUPERTINO, CA 95014, U.S.A.

EUT DESCRIPTION: TABLET DEVICE

MODEL: A1584

SERIAL NUMBER: DLXQ1005GPCT (Radiated), DLXQ1005GPCP (Conducted)

DATE TESTED: JULY 20, 2015 - AUGUST 19, 2015

APPLICABLE STANDARDS	
STANDARD	TEST RESULTS
CFR 47 Part 15 Subpart C	Pass
INDUSTRY CANADA RSS-247 Issue 1	Pass
INDUSTRY CANADA RSS-GEN Issue 4	Pass

UL Verification Services Inc. tested the above equipment in accordance with the requirements set forth in the above standards. All indications of Pass/Fail in this report are opinions expressed by UL Verification Services Inc. based on interpretations and/or observations of test results. Measurement Uncertainties were not taken into account and are published for informational purposes only. The test results show that the equipment tested is capable of demonstrating compliance with the requirements as documented in this report.

Note: The results documented in this report apply only to the tested sample, under the conditions and modes of operation as described herein. This document may not be altered or revised in any way unless done so by UL Verification Services Inc. and all revisions are duly noted in the revisions section. Any alteration of this document not carried out by UL Verification Services Inc. will constitute fraud and shall nullify the document. This report must not be used by the client to claim product certification, approval, or endorsement by NVLAP, NIST, any agency of the Federal Government, or any agency of any government.

Approved & Released For
UL Verification Services Inc. By:



CHIN PANG
SENIOR ENGINEER
UL VERIFICATION SERVICES INC.

Tested By:



ERIC YU
EMC ENGINEER
UL VERIFICATION SERVICES INC.

2. TEST METHODOLOGY

The tests documented in this report were performed in accordance with FCC CFR 47 Part 2, FCC CFR 47 Part 15, RSS-GEN Issue 4, and RSS-247 Issue 1, and ANSI C63.10-2013.

3. FACILITIES AND ACCREDITATION

The test sites and measurement facilities used to collect data are located at 47173 and 47266 Benicia Street, Fremont, California, USA. Line conducted emissions are measured only at the 47173 address. The following table identifies which facilities were utilized for radiated emission measurements documented in this report. Specific facilities are also identified in the test results sections.

47173 Benicia Street	47266 Benicia Street
<input type="checkbox"/> Chamber A	<input checked="" type="checkbox"/> Chamber D
<input type="checkbox"/> Chamber B	<input type="checkbox"/> Chamber E
<input type="checkbox"/> Chamber C	<input type="checkbox"/> Chamber F
	<input checked="" type="checkbox"/> Chamber G
	<input type="checkbox"/> Chamber H

The above test sites and facilities are covered under FCC Test Firm Registration # 208313. Chambers A through H are covered under Industry Canada company address code 2324B with site numbers 2324B -1 through 2324B-8, respectively.

UL Verification Services Inc. is accredited by NVLAP, Laboratory Code 200065-0. The full scope of accreditation can be viewed at <http://ts.nist.gov/standards/scopes/2000650.htm>.

4. CALIBRATION AND UNCERTAINTY

4.1. MEASURING INSTRUMENT CALIBRATION

The measuring equipment utilized to perform the tests documented in this report has been calibrated in accordance with the manufacturer's recommendations, and is traceable to recognized national standards.

4.2. SAMPLE CALCULATION

Where relevant, the following sample calculation is provided:

$$\begin{aligned} \text{Field Strength (dBuV/m)} &= \text{Measured Voltage (dBuV)} + \text{Antenna Factor (dB/m)} + \\ &\text{Cable Loss (dB)} - \text{Preamp Gain (dB)} \\ 36.5 \text{ dBuV} + 18.7 \text{ dB/m} + 0.6 \text{ dB} - 26.9 \text{ dB} &= 28.9 \text{ dBuV/m} \end{aligned}$$

4.3. MEASUREMENT UNCERTAINTY

Where relevant, the following measurement uncertainty levels have been estimated for tests performed on the apparatus:

PARAMETER	UNCERTAINTY
Conducted Disturbance, 0.15 to 30 MHz	± 3.52 dB
Radiated Disturbance, 30 to 1000 MHz	± 4.94 dB
Radiated Disturbance, 1 to 6 GHz	± 3.86 dB
Radiated Disturbance, 6 to 18 GHz	± 4.23 dB
Radiated Disturbance, 18 to 26 GHz	± 5.30 dB
Radiated Disturbance, 26 to 40 GHz	± 5.23 dB

Uncertainty figures are valid to a confidence level of 95%.

5. EQUIPMENT UNDER TEST

5.1. DESCRIPTION OF EUT

The EUT is a tablet with multimedia functions (music, application support, and video), IEEE 802.11a/b/g/n/ac radio, and Bluetooth radio. The rechargeable battery is not user accessible.

5.2. MAXIMUM OUTPUT POWER

The transmitter has a maximum peak conducted output power as follows:

Frequency Range (MHz)	Mode	Output Power (dBm)	Output Power (mW)
2402 - 2480	BLE	9.12	8.17

5.3. DESCRIPTION OF AVAILABLE ANTENNAS

Frequency Band (GHz)	Antenna Gain
2.4	-0.60

5.4. SOFTWARE AND FIRMWARE

The software installed in the EUT during testing was 13B72.

5.5. WORST-CASE CONFIGURATION AND MODE

Radiated emission and power line conducted emission were performed with the EUT set to transmit at the channel with highest output power as worst-case scenario.

The Murata chipset was determined to be the worst case for BLE.

The fundamental of the EUT was investigated in three orthogonal orientations X/Y/Z, it was determined that Y (Landscape) orientation was worst-case orientation. Therefore, all final radiated testing was performed with the EUT in Y orientation.

Worst-case data rates as provided by the client were:

Based on the baseline scan, the worst-case data rates were:

BLE: 1 Mbps.

For simultaneous transmission of multiple channels from the same antenna in BT/BLE and WLAN 5 GHz bands. Baseline testing was performed on various configurations to determine the worst case on radiated emissions.

The following configurations were investigated on AC line conducted test.

Configuration	Descriptions
1	EUT powered by AC/DC adapter via USB cable
2	EUT powered by host PC via USB cable

There are two vendors of the WiFi/Bluetooth radio modules: variant 1 and variant 2 and they have the same mechanical outline, same on board antenna, matching circuit, antenna structure and same specification. Baseline testing was performed on all two variants to determine the worst case on all conducted power and radiated emissions.

5.6. DESCRIPTION OF TEST SETUP

SUPPORT EQUIPMENT

Support Equipment List				
Description	Manufacturer	Model	Serial Number	FCC ID
Laptop AC/DC adapter	Lenovo	92P1160	11S92P1160Z1ZBGH798B12	N/A
Laptop	Lenovo	7659	L3-AL664 08/03	N/A
Earphone	Apple	N/A	N/A	N/A
EUT AC/CD adapter	Apple	A1385	D293062F3WVDHLHCF	N/A

I/O CABLES (CONDUCTED TEST)

I/O Cable List						
Cable No	Port	# of identical ports	Connector Type	Cable Type	Cable Length (m)	Remarks
1	Antenna	1	SMA	Un-Shielded	0.2	To spectrum Analyzer
2	USB	1	USB	Shielded	1	N/A
3	AC	1	AC	Un-shielded	3	N/A

I/O CABLES (RADIATED ABOVE 1 GHZ)

I/O Cable List						
Cable No	Port	# of identical ports	Connector Type	Cable Type	Cable Length (m)	Remarks
None Used						

I/O CABLES (RADAITED BELOW 1 GHZ)

I/O Cable List						
Cable No	Port	# of identical	Connector Type	Cable Type	Cable Length (m)	Remarks
1	Headphones Jack	1	3.5mm Audio	Shielded	0.9	N/A
2	AC	1	AC	Un-shielded	3	N/A

I/O CABLES (AC LINE CONDUCTED: AC/DC ADAPTER)

I/O Cable List						
Cable No	Port	# of identical	Connector Type	Cable Type	Cable Length (m)	Remarks
1	Headphones Jack	1	3.5mm Audio	Shielded	0.9	N/A
2	AC	1	AC	Un-shielded	3	N/A

I/O CABLES (AC LINE CONDUCTED: LAPTOP CONFIGUARTION)

I/O Cable List						
Cable No	Port	# of identical	Connector Type	Cable Type	Cable Length (m)	Remarks
1	Headphones Jack	1	3.5mm Audio	Shielded	0.9	N/A
2	USB	1	USB	Shielded	1	N/A
3	AC	1	AC	Un-shielded	3	N/A

TEST SETUP - CONDUCTED TESTS

The EUT was tested connected to a host Laptop via USB cable adapter and spectrum analyzer to antenna port. Test software exercised the EUT.

SETUP DIAGRAM

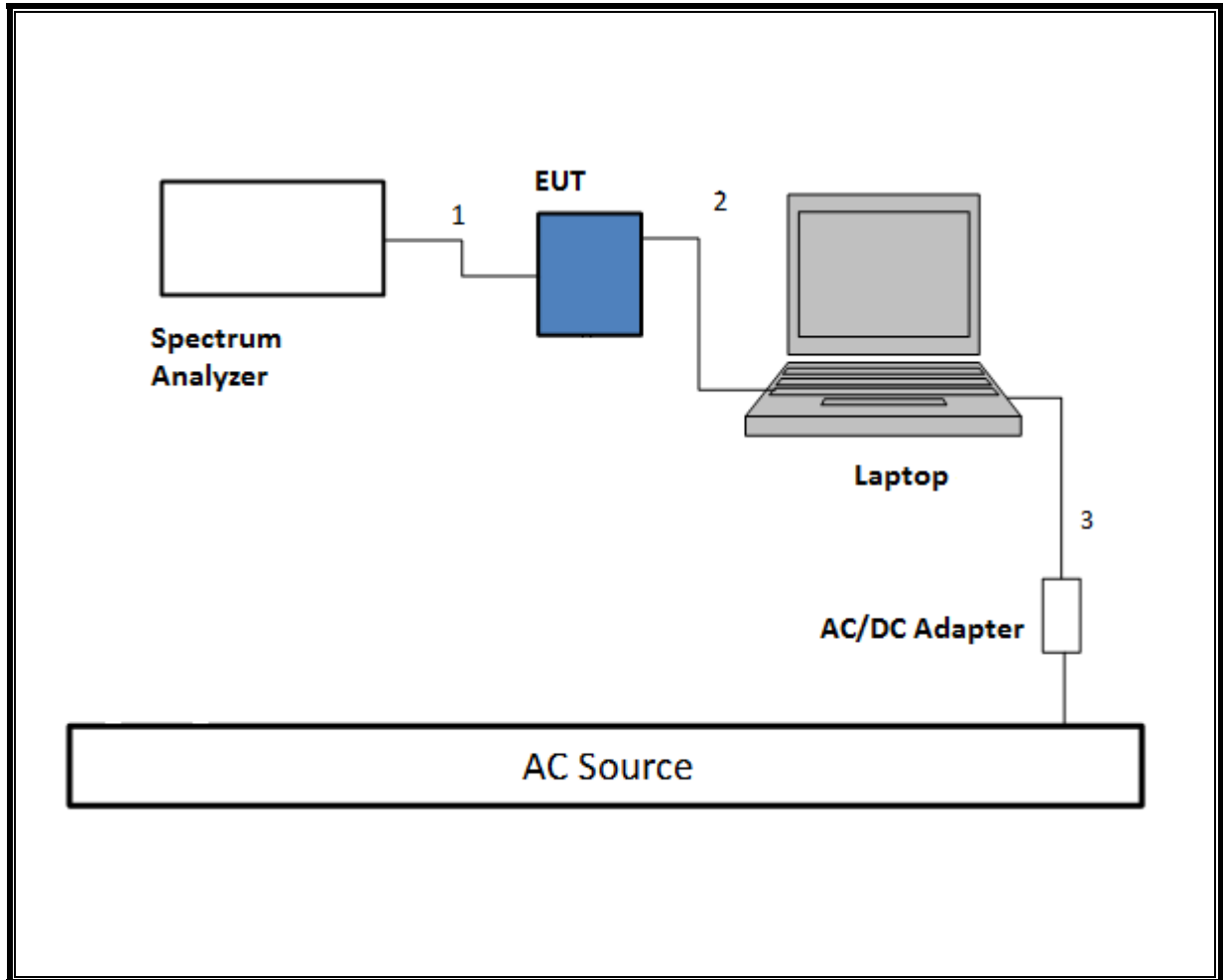

TEST SETUP- RADIATED-ABOVE 1 GHZ

The EUT was tested battery powered. Test software exercised the EUT.

SETUP DIAGRAM

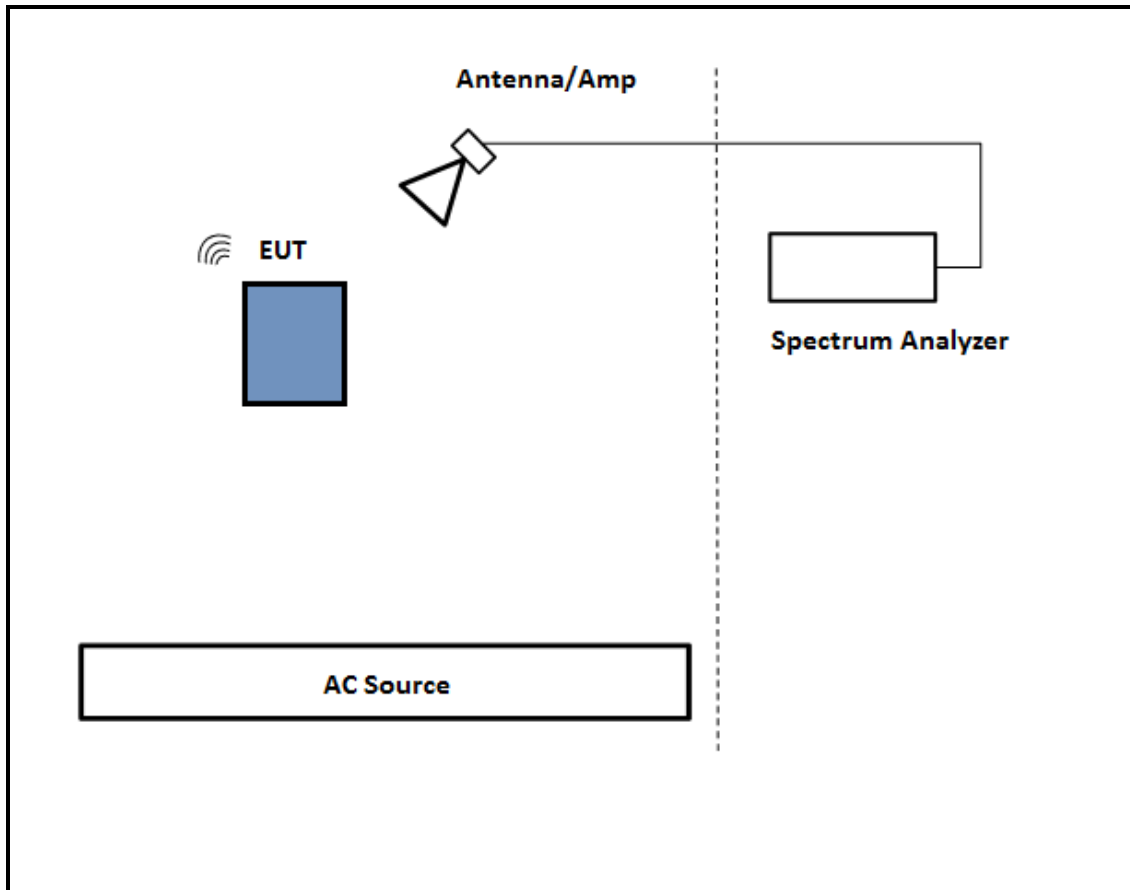

TEST SETUP- BELOW 1GHz

The EUT was tested with earphone connected and powered by AC adapter. Test software exercised the EUT.

SETUP DIAGRAM

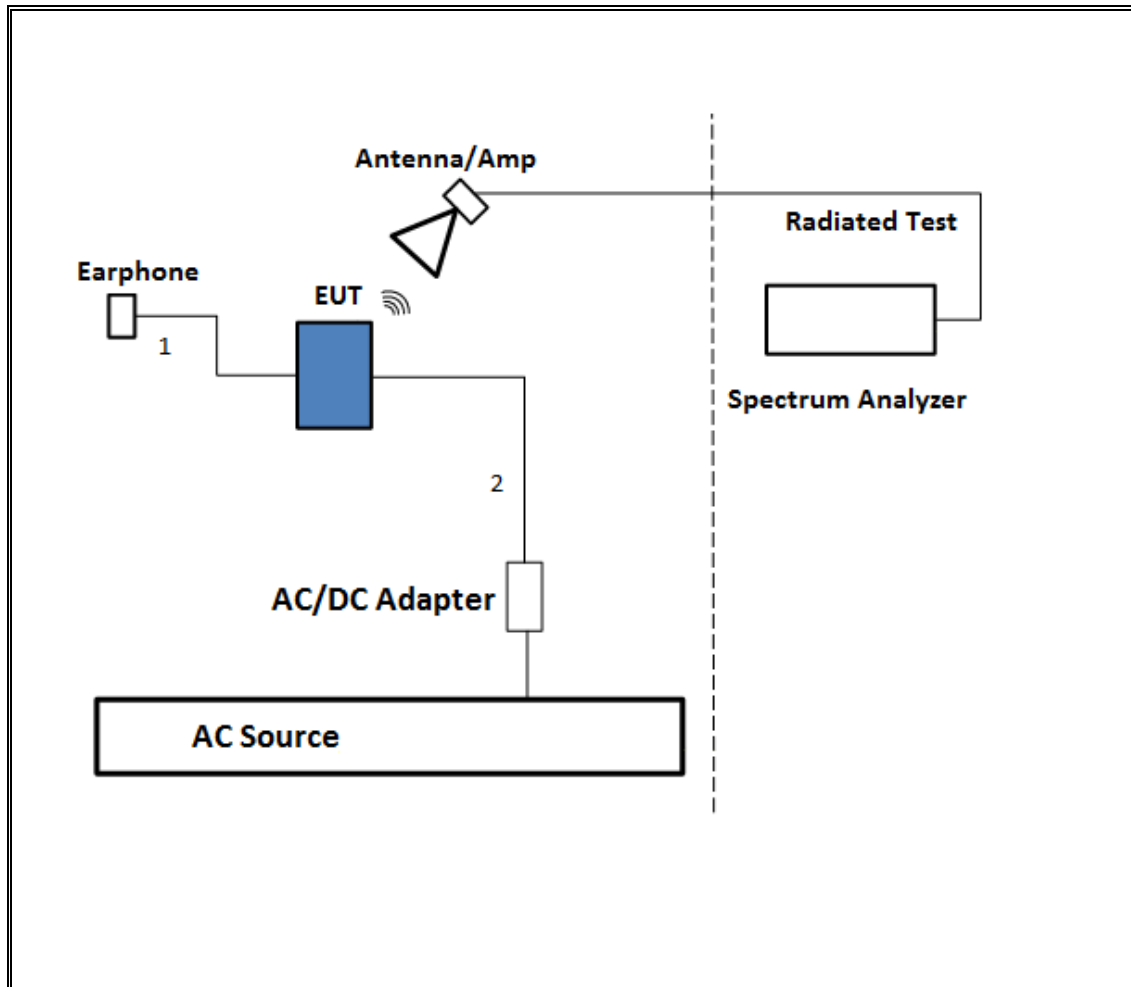

TEST SETUP- AC LINE CONDUCTED: AC/DC ADAPTER

The EUT was tested with earphone connected and powered by AC/DC adapter via USB cable. Test software exercised the EUT.

SETUP DIAGRAM

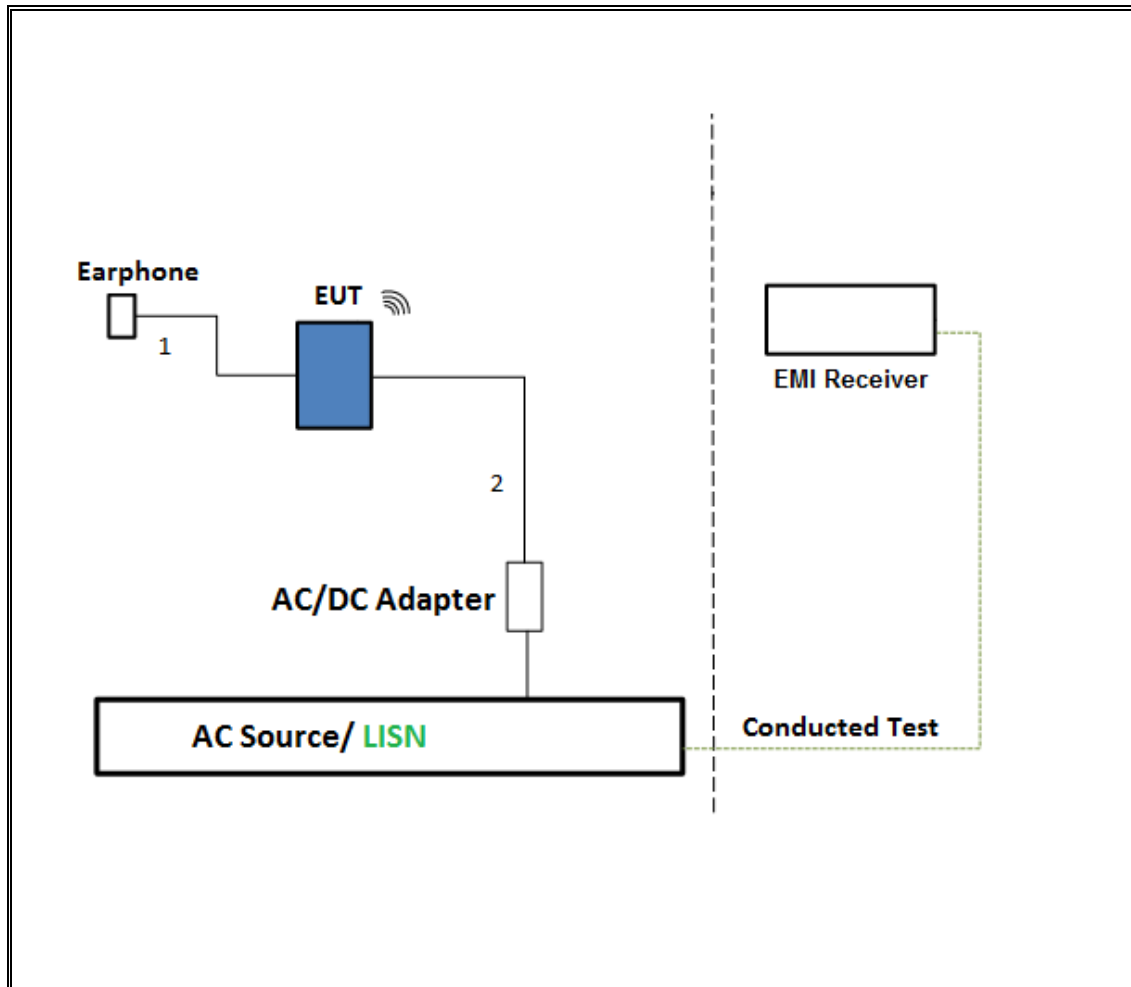

TEST SETUP- AC LINE CONDUCTED: LAPTOP CONFIGURATION

The EUT was tested with earphone connected and powered by host PC via USB cable. Test software exercised the EUT.

SETUP DIAGRAM

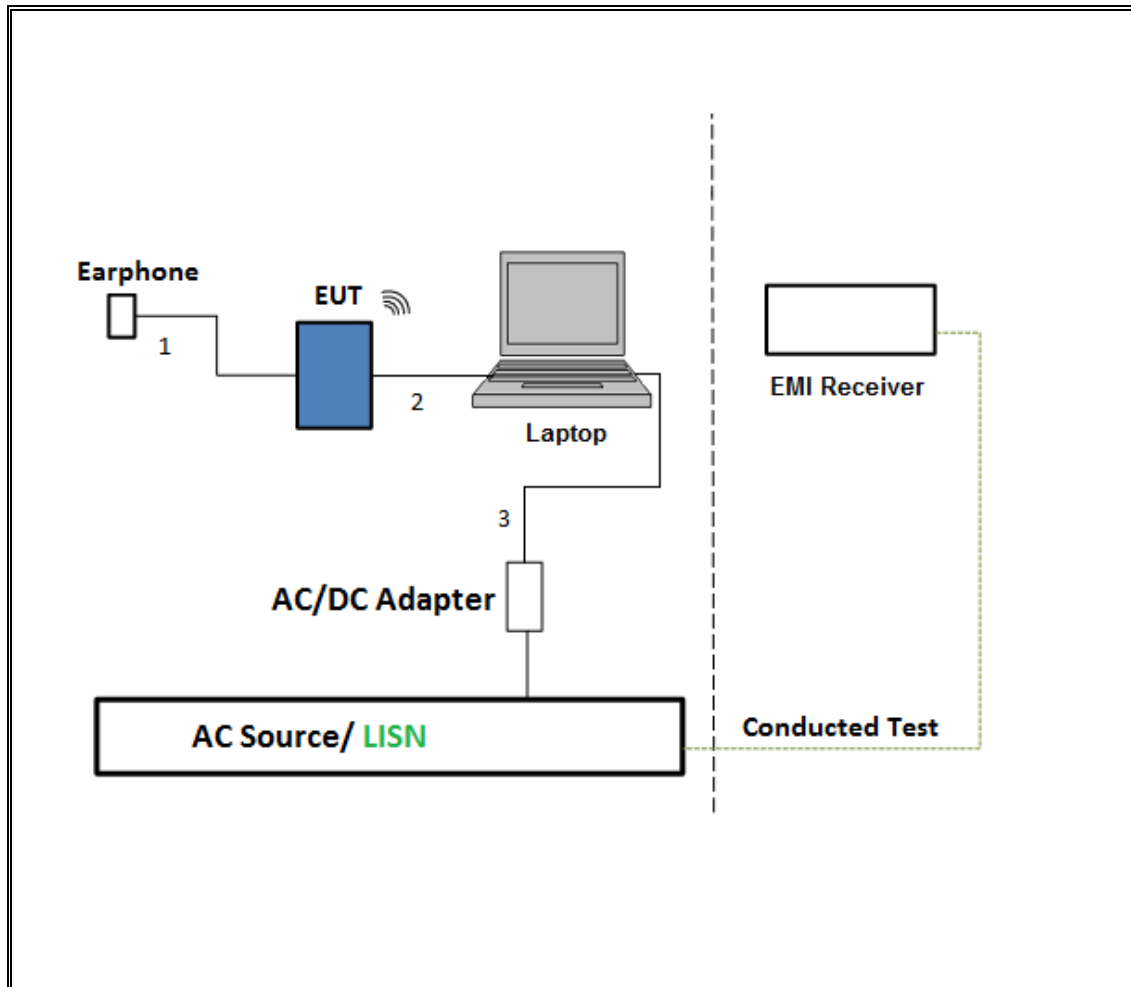

6. TEST AND MEASUREMENT EQUIPMENT

The following test and measurement equipment was utilized for the tests documented in this report:

Test Equipment List				
Description	Manufacturer	Model	Asset	Cal Due
Antenna, Horn 1-18GHz	ETS Lindgren	3117	00143448	2/10/2016
Antenna, Broadband Hybrid, 30MHz to 2000MHz	Sunol Sciences	JB3	A022813-1	1/14/2016
Amplifier, 1 - 18GHz	Miteq	AFS42-00101800-25-S-42	1782158	1/26/2016
Amplifier, 10KHz to 1GHz, 32dB	Sonoma	310N	171202	11/1/2015
Spectrum Analyzer, PXA, 3Hz to 50GHz	Agilent	N9030A	MY52350427	9/13/2015
Amplifier, 10KHz to 1GHz, 32dB	Sonoma	310N	325118	2/14/2016
Spectrum Analyzer, PXA, 3Hz to 44GHz	Agilent	N9030A	MY52350675	3/16/2016
Power Meter, P-series single channel	Agilent	N1911A	GB45100212	10/9/2015
Power Sensor, P - series, 50MHz to 18GHz, Wideband	Agilent	N1921A	MY53260010	4/7/2016
Antenna, Horn 18 to 26.5GHz	ARA	MWH-1826	1049	12/17/2015
Amplifier, 1 to 26.5GHz, 23.5dB Gain minimum	Agilent	8449B	3008A01114	10/4/2015
AC Line Conducted				
EMI Test Receiver 9KHz-7GHz	Rohde & Schwarz	ESCI7	100935	9/16/2015
LISN for Conducted Emissions CISPR-16	FCC	50/250-25-2	114	1/16/2016
Power Cable, Line Conducted Emissions ANSI 63.4	U L	PG1	N/A	7/28/2015
UL SOFTWARE				
*Radiated Software	UL	UL EMC	Ver 9.5, July 22, 2014	
*Conducted Software	UL	UL EMC	Ver 2.2, March 31, 2015	
*AC Line Conducted Software	UL	UL EMC	Ver 9.5, April 3, 2015	

Note: * indicates automation software version used in the compliance certification testing

7. ANTENNA PORT TEST RESULTS

7.1. MEASUREMENT METHODS

MEASUREMENT METHODS

6 dB BW: KDB 558074 D01 v03r03, Section 8.1.

Output Power: KDB 558074 D01 v03r03, Section 9.1.2.

Power Spectral Density: KDB 558074 D01 v03r03, Section 10.2.

Out-of-band emissions in non-restricted bands: KDB 558074 D01 v03r03, Section 11.0.

Out-of-band emissions in restricted bands: KDB 558074 D01 v03r03, Section 12.1.

Band-edge: KDB 558074 D01 v03r03, Section 12.1

7.2. ON TIME, DUTY CYCLE

LIMITS

None; for reporting purposes only.

PROCEDURE

KDB 558074 Zero-Span Spectrum Analyzer Method.

ON TIME AND DUTY CYCLE RESULTS

Mode	ON Time B (msec)	Period (msec)	Duty Cycle x (linear)	Duty Cycle (%)	Duty Cycle Correction Factor (dB)	1/B Minimum VBW (kHz)
BLE	5.000	5.000	1.000	100.00%	0.00	0.010

7.3. 6 dB BANDWIDTH

LIMITS

FCC §15.247 (a) (2)

IC RSS-247 (5.2) (1)

The minimum 6 dB bandwidth shall be at least 500 kHz.

RESULTS

Channel	Frequency (MHz)	6 dB Bandwidth (MHz)	Minimum Limit (MHz)
Low	2402	0.7196	0.5
Middle	2440	0.7196	0.5
High	2480	0.7182	0.5

6 dB BANDWIDTH

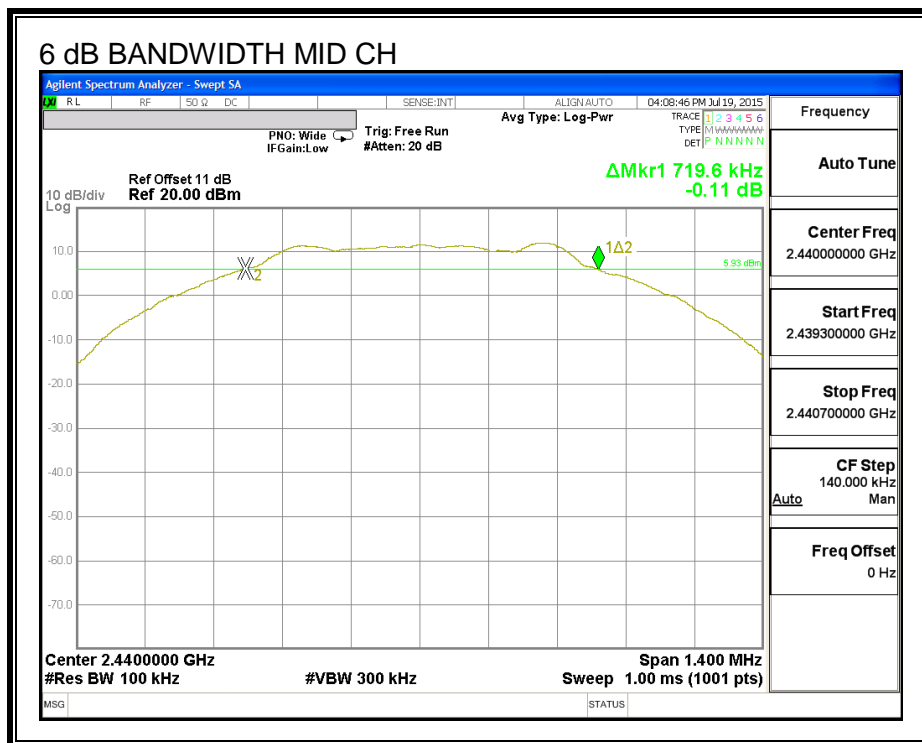
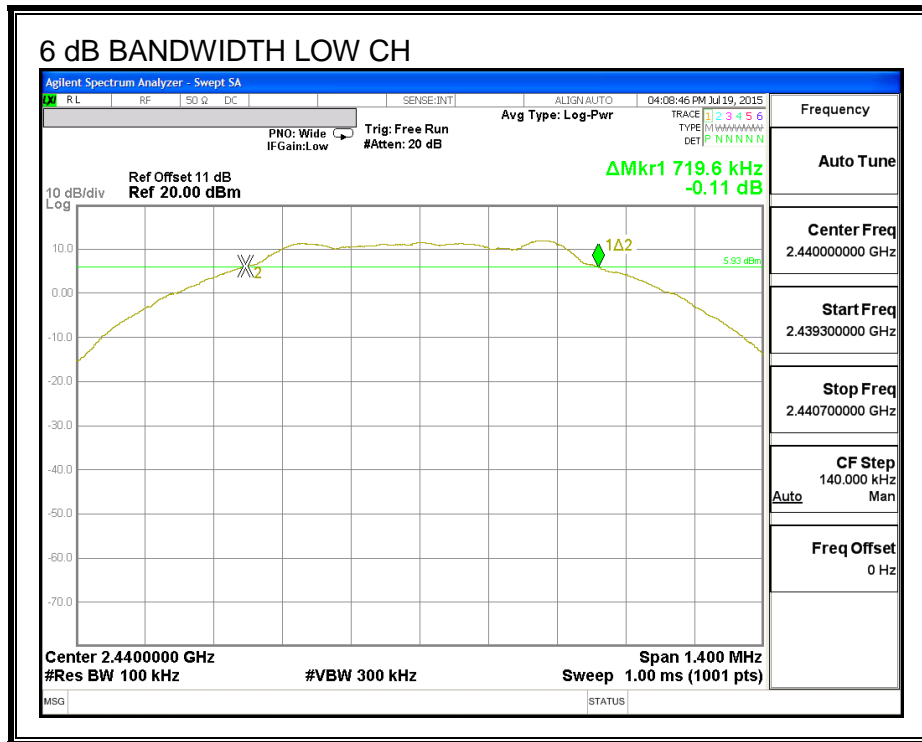

7.4. 99% BANDWIDTH

LIMITS

None; for reporting purposes only.

TEST PROCEDURE

The transmitter output is connected to the spectrum analyzer. The RBW is set to 1% to 3% of the 99 % bandwidth and to 1% of the span. The VBW is set to 3 times the RBW. The sweep time is coupled. The spectrum analyzer internal 99% bandwidth function is utilized.

RESULTS

Channel	Frequency (MHz)	99% Bandwidth (MHz)
Low	2402	1.0520
Middle	2440	1.0395
High	2480	1.0386

99% BANDWIDTH

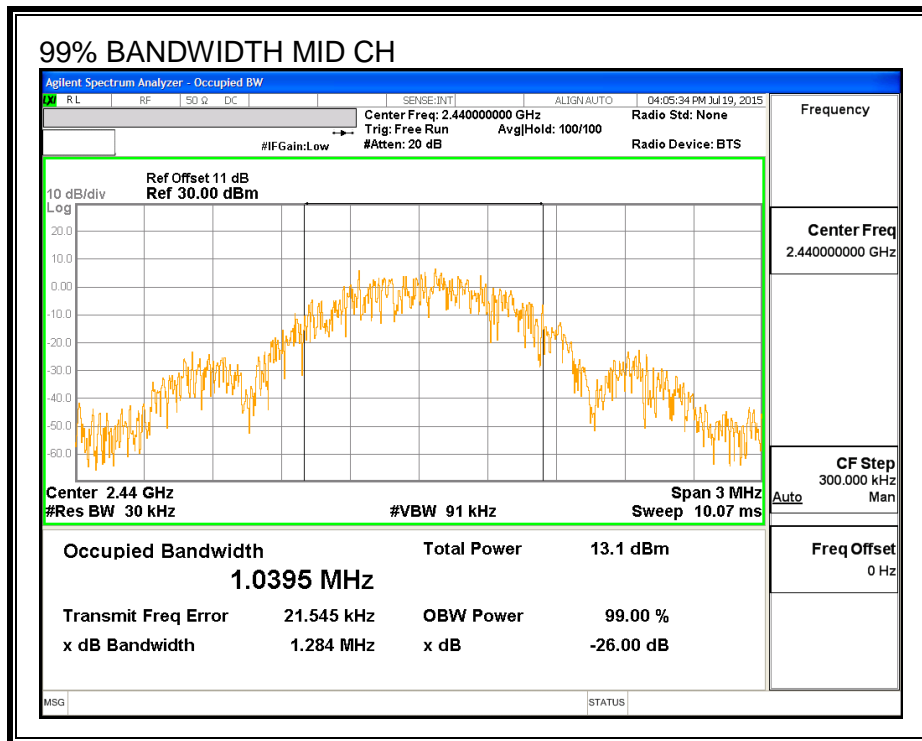
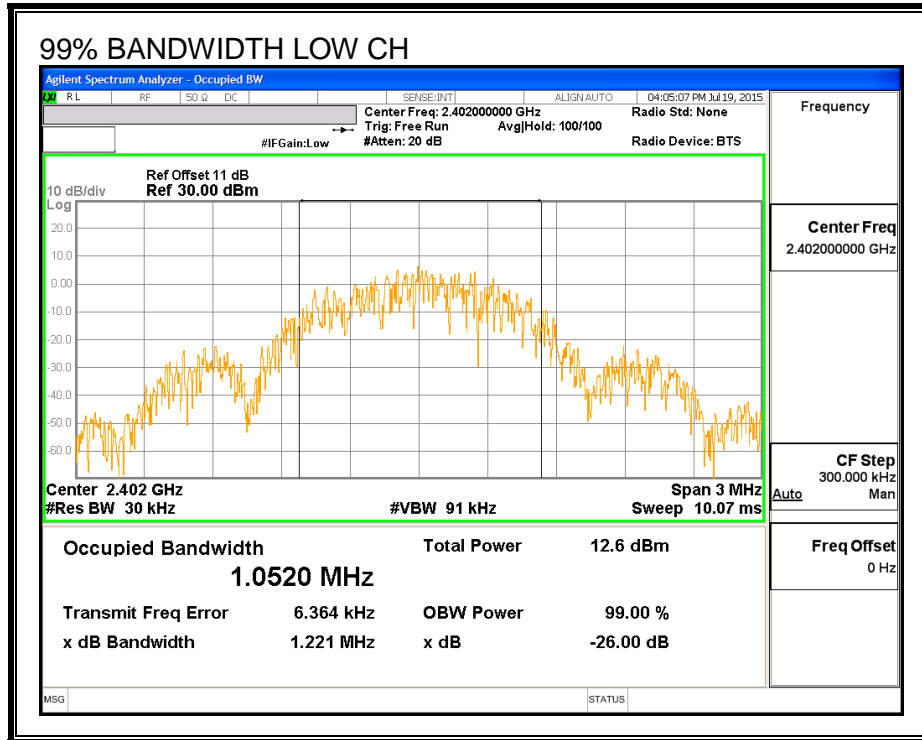

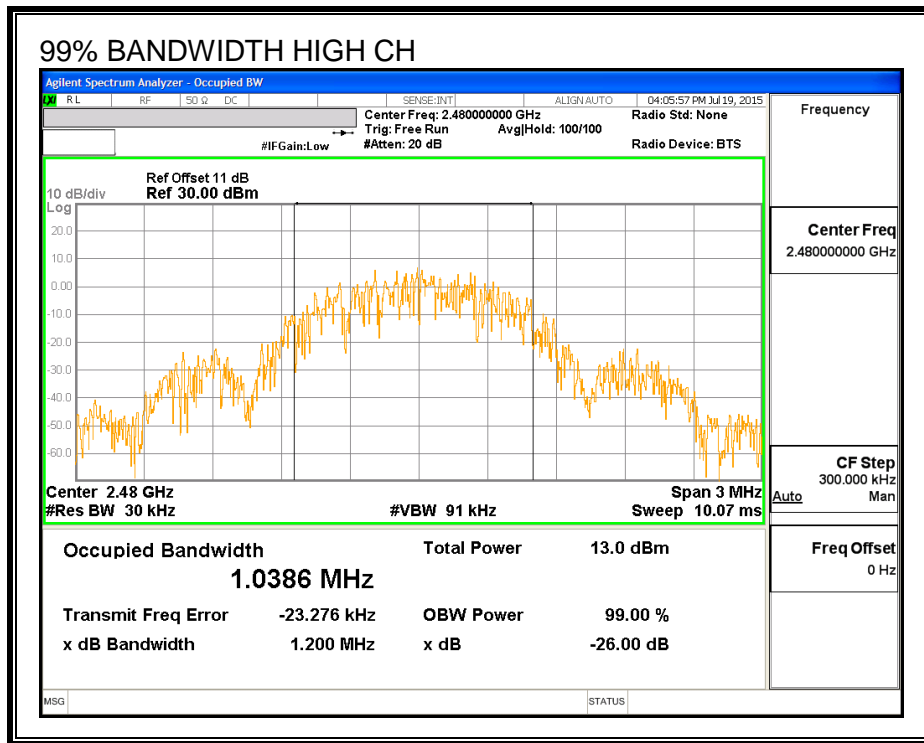

7.5. AVERAGE POWER

LIMITS

None; for reporting purposes only.

RESULTS

The cable assembly insertion loss of 11 dB (including 10 dB pad and 1 dB cable) was entered as an offset in the power meter to allow for direct reading of power.

Channel	Frequency (MHz)	AV power (dBm)
Low	2402	8.95
Middle	2440	8.31
High	2480	8.44

7.6. OUTPUT POWER

LIMITS

FCC §15.247 (b)

IC RSS-247 (5.4) (4)

The maximum antenna gain is less than or equal to 6 dBi, therefore the limit is 30 dBm.

RESULTS

Channel	Frequency (MHz)	Peak Power Reading (dBm)	Limit (dBm)	Margin (dB)
Low	2402	9.12	30	-20.880
Middle	2440	8.50	30	-21.500
High	2480	8.59	30	-21.410

7.7. POWER SPECTRAL DENSITY

LIMITS

FCC §15.247 (e)

IC RSS-247 (5.2) (2)

The power spectral density conducted from the transmitter to the antenna shall not be greater than 8 dBm in any 3 kHz band during any time interval of continuous transmission.

RESULTS

Channel	Frequency (MHz)	PSD (dBm)	Limit (dBm)	Margin (dB)
Low	2402	-7.45	8	-15.45
Middle	2440	-7.42	8	-15.42
High	2480	-7.12	8	-15.12

POWER SPECTRAL DENSITY

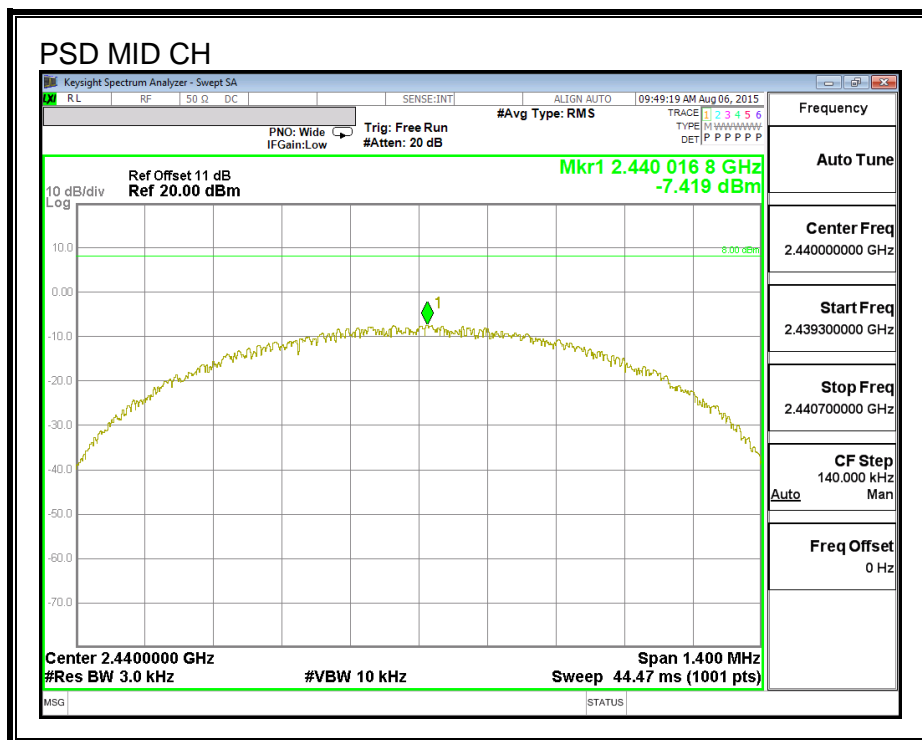
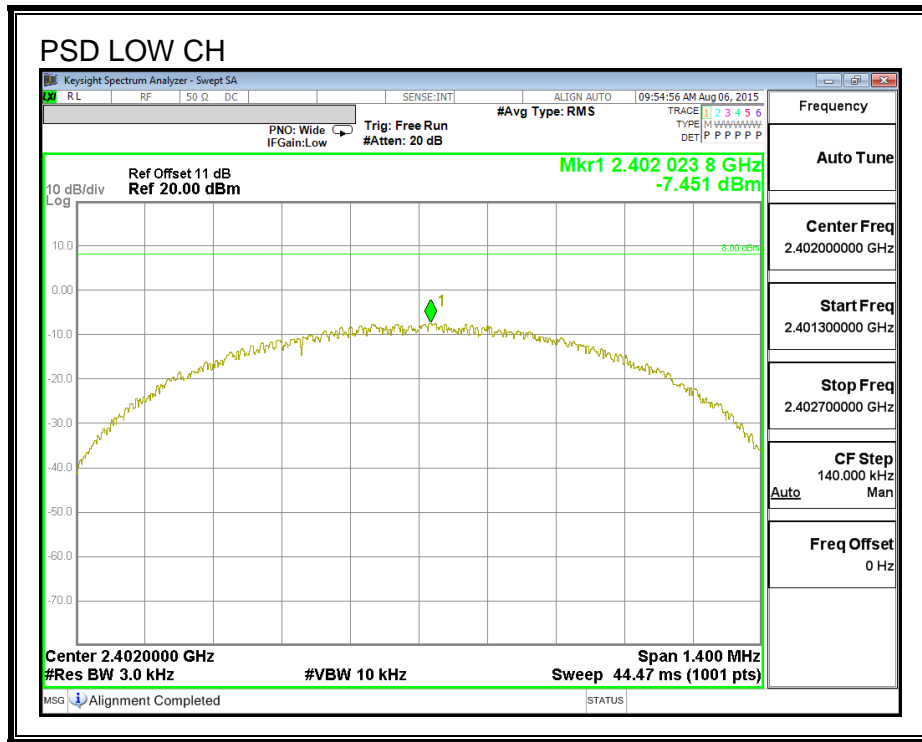

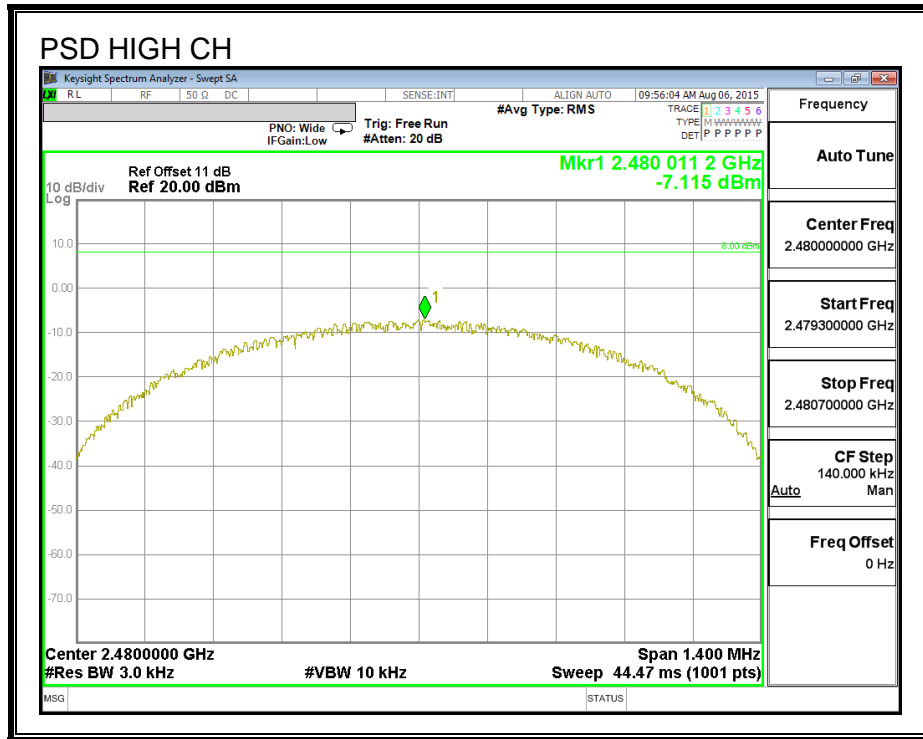

7.8. CONDUCTED SPURIOUS EMISSIONS

LIMITS

FCC §15.247 (d)

IC RSS-247 (5.5)

Output power was measured based on the use of a peak measurement, therefore the required attenuation is 20 dB.

RESULTS

SPURIOUS EMISSIONS, LOW CHANNEL

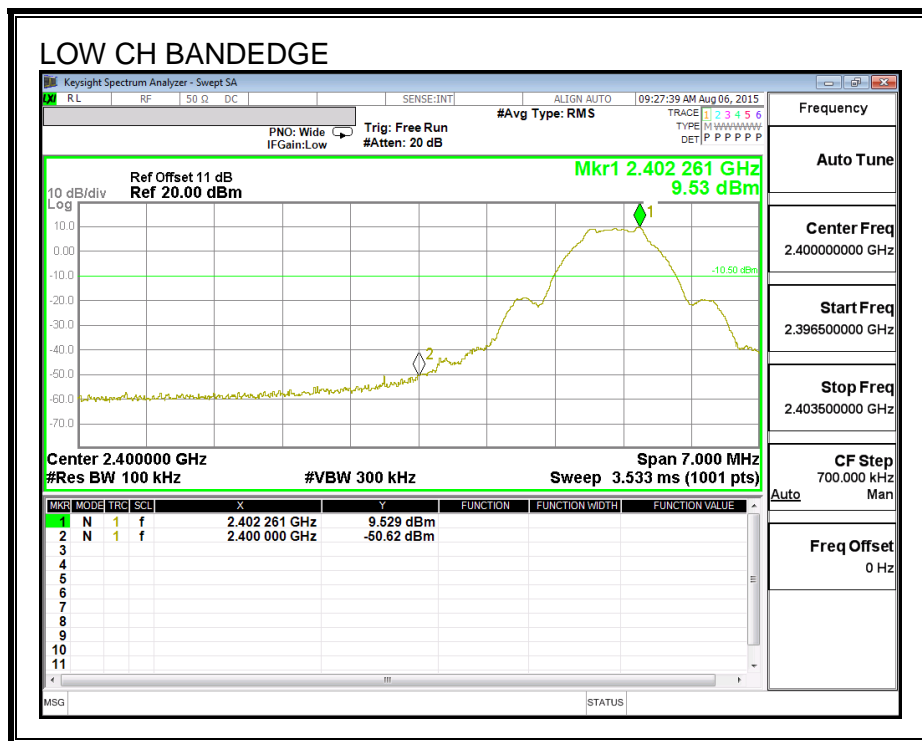

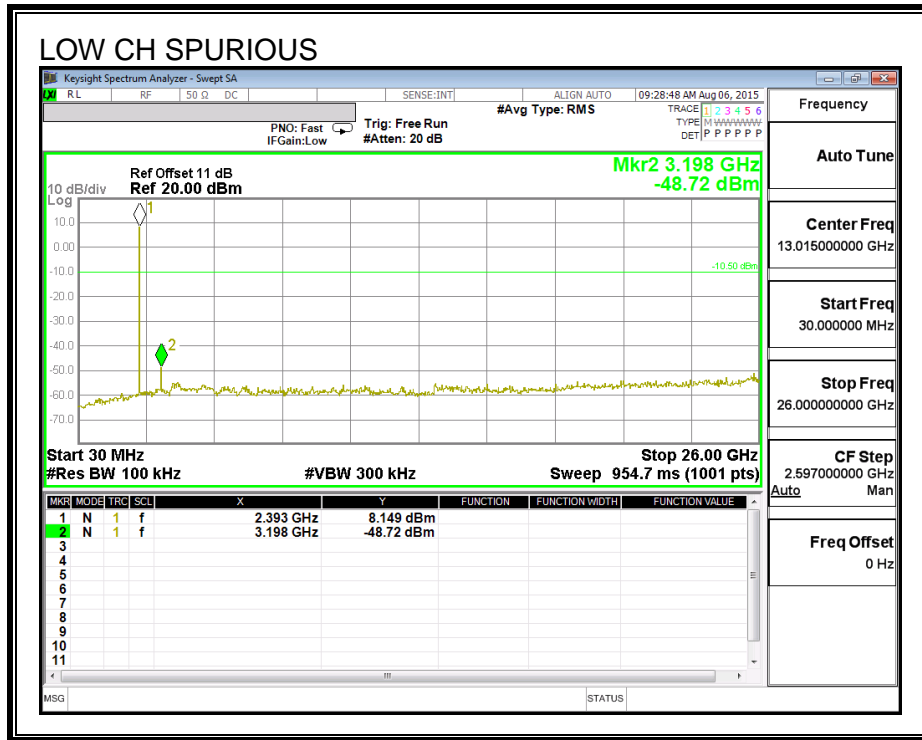

SPURIOUS EMISSIONS, MID CHANNEL

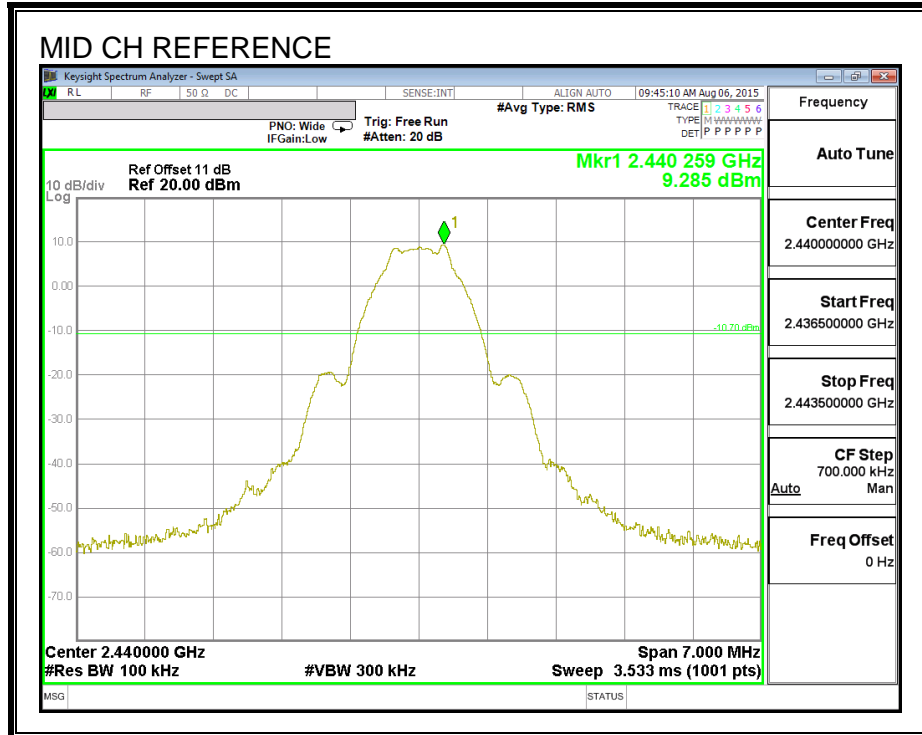

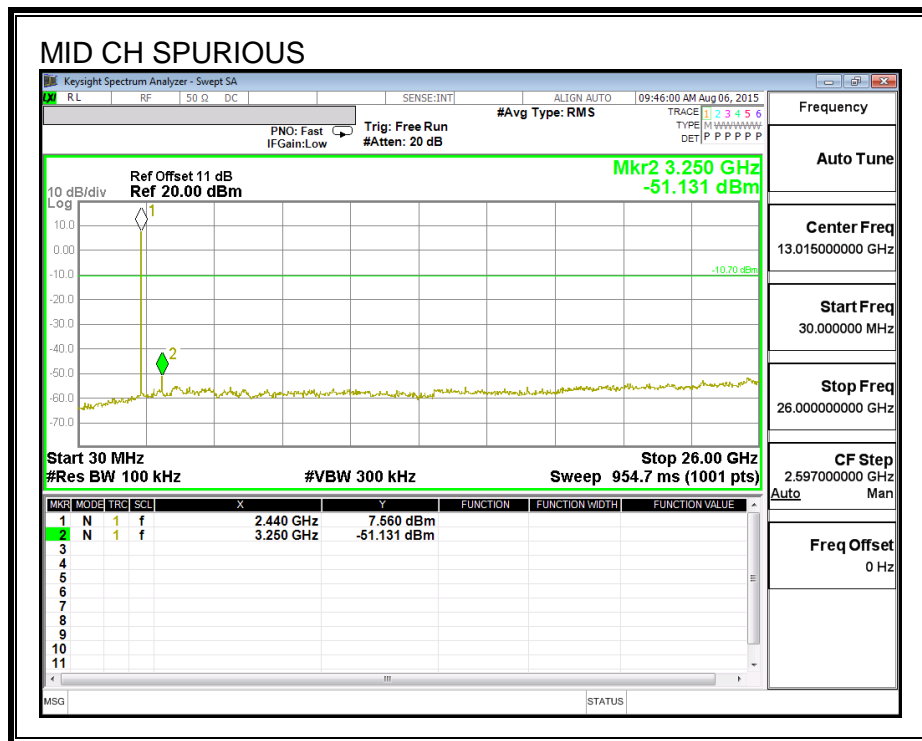

SPURIOUS EMISSIONS, HIGH CHANNEL

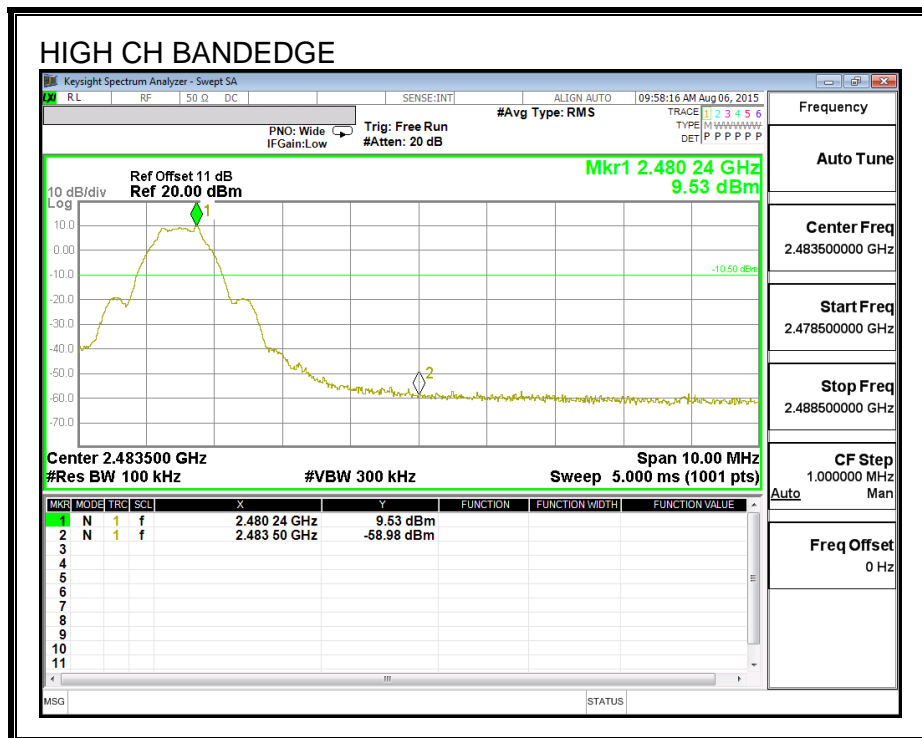

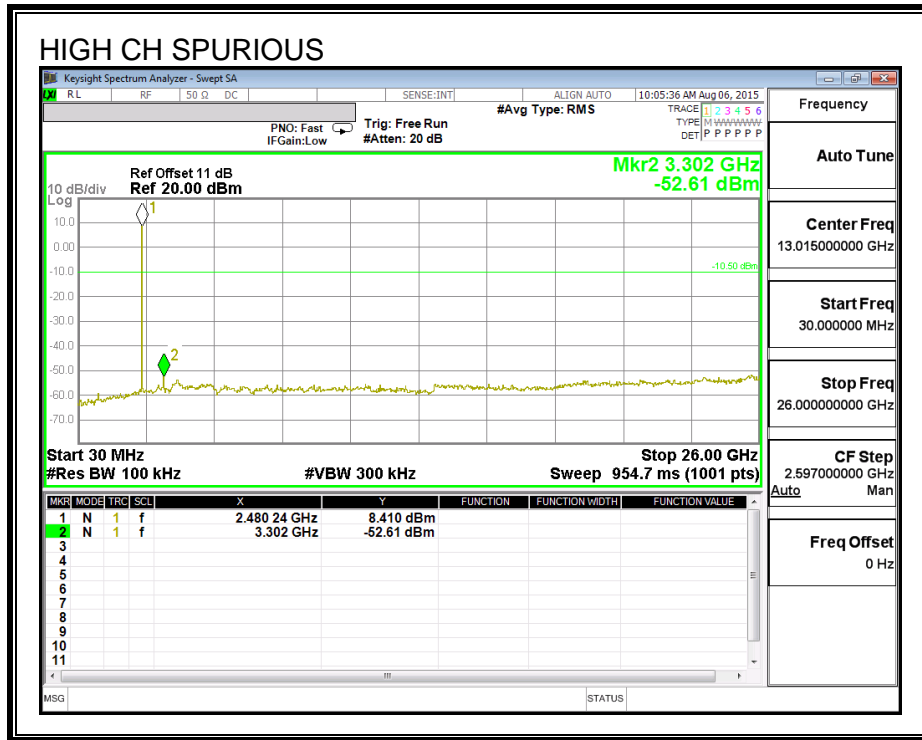

8. RADIATED TEST RESULTS

8.1. LIMITS AND PROCEDURE

LIMITS

FCC §15.205 and §15.209

IC RSS-GEN, Section 8.9 and 8.10.

Frequency Range (MHz)	Field Strength Limit (uV/m) at 3 m	Field Strength Limit (dBuV/m) at 3 m
30 - 88	100	40
88 - 216	150	43.5
216 - 960	200	46
Above 960	500	54

TEST PROCEDURE

The EUT is placed on a non-conducting table 80 cm above the ground plane for measurement below 1GHz; 1.5 m above the ground plane for measurement above 1GHz. The antenna to EUT distance is 3 meters. The EUT is configured in accordance with ANSI C63.10. The EUT is set to transmit in a continuous mode.

For measurements below 1 GHz the resolution bandwidth is set to 100 kHz for peak detection measurements or 120 kHz for quasi-peak detection measurements. Peak detection is used unless otherwise noted as quasi-peak.

For measurements above 1 GHz the resolution bandwidth is set to 1 MHz, then the video bandwidth is set to 3 MHz for peak measurements and 1 MHz resolution bandwidth with 3MHz video bandwidth with average detector for average measurements.

The spectrum from 30 MHz to 26 GHz is investigated with the transmitter set to the lowest, middle, and highest channels in the 2.4 GHz band.

The frequency range of interest is monitored at a fixed antenna height and EUT azimuth. The EUT is rotated through 360 degrees to maximize emissions received. The antenna is scanned from 1 to 4 meters above the ground plane to further maximize the emission. Measurements are made with the antenna polarized in both the vertical and the horizontal positions.

8.2. TRANSMITTER ABOVE 1 GHz

8.2.1. RESTRICTED BANDEGE

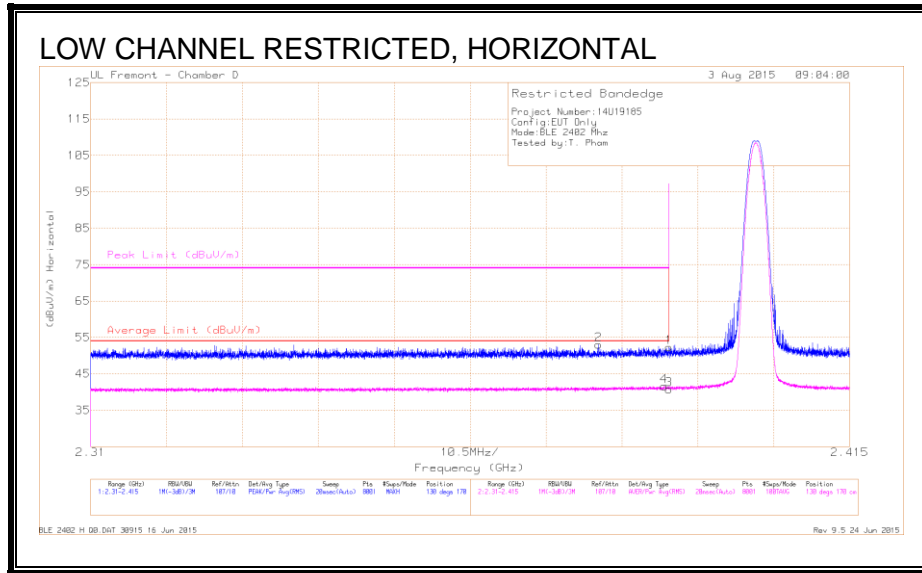

DATA

Marker	Frequency (GHz)	Meter Reading (dBuV)	Det	AF T344 (dB/m)	Amp/Cbl/ Ftr/Pad (dB)	Corrected Reading (dBuV/m)	Average Limit (dBuV/m)	Margin (dB)	Peak Limit (dBuV/m)	PK Margin (dB)	Azimuth (Degs)	Height (cm)	Polarity
1	* 2.39	40.88	Pk	32.1	-20.7	52.28	-	-	74	-21.72	130	170	H
2	* 2.38	41.77	Pk	32.1	-20.8	53.07	-	-	74	-20.93	130	170	H
3	* 2.39	29.29	RMS	32.1	-20.7	40.69	54	-13.31	-	-	130	170	H
4	* 2.389	30.23	RMS	32.1	-20.7	41.63	54	-12.37	-	-	130	170	H

* - indicates frequency in CFR 47, Part 15 and Industry Canada RSS-Restricted Band.

PK - Peak detector

RMS - RMS detection

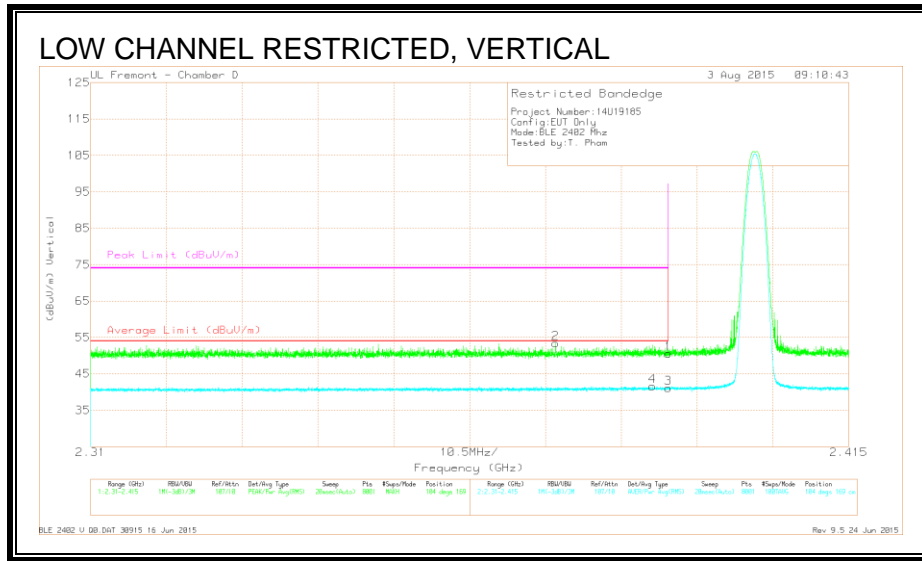

DATA

Marker	Frequency (GHz)	Meter Reading (dBuV)	Det	AF T344 (dB/m)	Amp/Cb/ Fitr/Pad (dB)	Corrected Reading (dBuV/m)	Average Limit (dBuV/m)	Margin (dB)	Peak Limit (dBuV/m)	PK Margin (dB)	Azimuth (Degs)	Height (cm)	Polarity
1	* 2.39	39.13	Pk	32.1	-20.7	50.53	-	-	74	-23.47	104	169	V
2	* 2.374	42.32	Pk	32	-20.9	53.42	-	-	74	-20.58	104	169	V
3	* 2.39	29.72	RMS	32.1	-20.7	41.12	54	-12.88	-	-	104	169	V
4	* 2.388	30.29	RMS	32.1	-20.8	41.59	54	-12.41	-	-	104	169	V

* - indicates frequency in CFR 47, Part 15 and Industry Canada RSS-Restricted Band.

PK - Peak detector

RMS - RMS detection

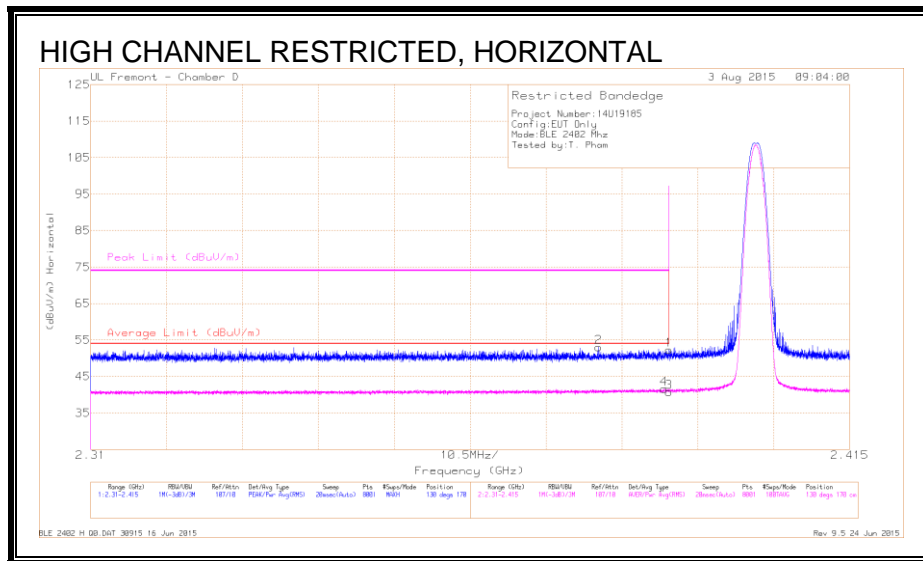

DATA

Marker	Frequency (GHz)	Meter Reading (dBuV)	Det	AFT344 (dB/m)	Amp/Cb/ Ftr/Pad (dB)	Corrected Reading (dBuV/m)	Average Limit (dBuV/m)	Margin (dB)	Peak Limit (dBuV/m)	PK Margin (dB)	Azimuth (Degs)	Height (cm)	Polarity
1	* 2.39	40.88	Pk	32.1	-20.7	52.28	-	-	74	-21.72	130	170	H
2	* 2.38	41.77	Pk	32.1	-20.8	53.07	-	-	74	-20.93	130	170	H
3	* 2.39	29.29	RMS	32.1	-20.7	40.69	54	-13.31	-	-	130	170	H
4	* 2.389	30.23	RMS	32.1	-20.7	41.63	54	-12.37	-	-	130	170	H

* - indicates frequency in CFR 47, Part 15 and Industry Canada RSS-Restricted Band.

PK - Peak detector

RMS - RMS detection

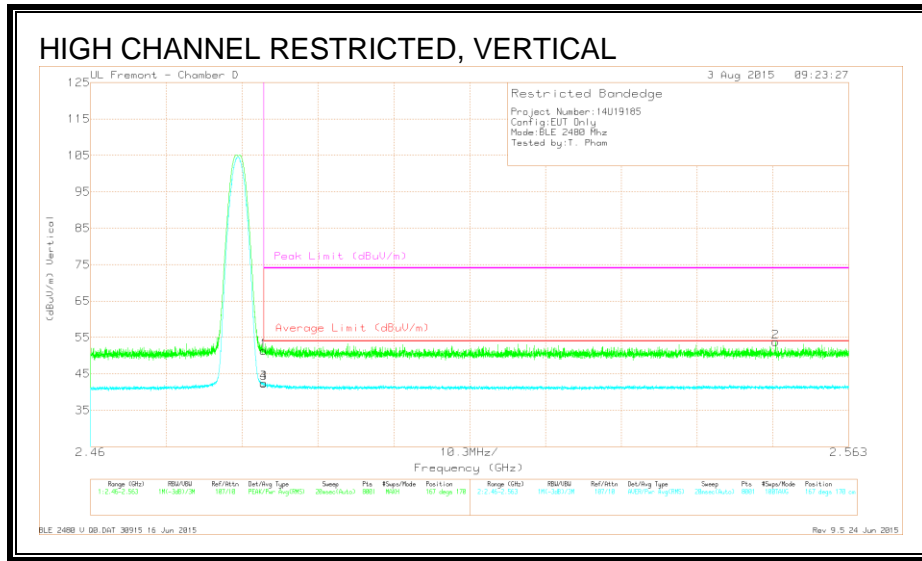

DATA

Marker	Frequency (GHz)	Meter Reading (dBuV)	Det	AF T344 (dB/m)	Amp/Cb/ Fitr/Pad (dB)	Corrected Reading (dBuV/m)	Average Limit (dBuV/m)	Margin (dB)	Peak Limit (dBuV/m)	PK Margin (dB)	Azimuth (Degs)	Height (cm)	Polarity
1	* 2.484	39.92	Pk	32.2	-20.8	51.32	-	-	74	-22.68	167	170	V
2	2.553	42.21	Pk	32.3	-20.7	53.81	-	-	74	-20.19	167	170	V
3	* 2.484	31.01	RMS	32.2	-20.8	42.41	54	-11.59	-	-	167	170	V
4	* 2.484	31.11	RMS	32.2	-20.8	42.51	54	-11.49	-	-	167	170	V

* - indicates frequency in CFR 47, Part 15 and Industry Canada RSS-Restricted Band.

PK - Peak detector

RMS - RMS detection

8.2.2. HARMONICS AND SPURIOUS EMISSIONS

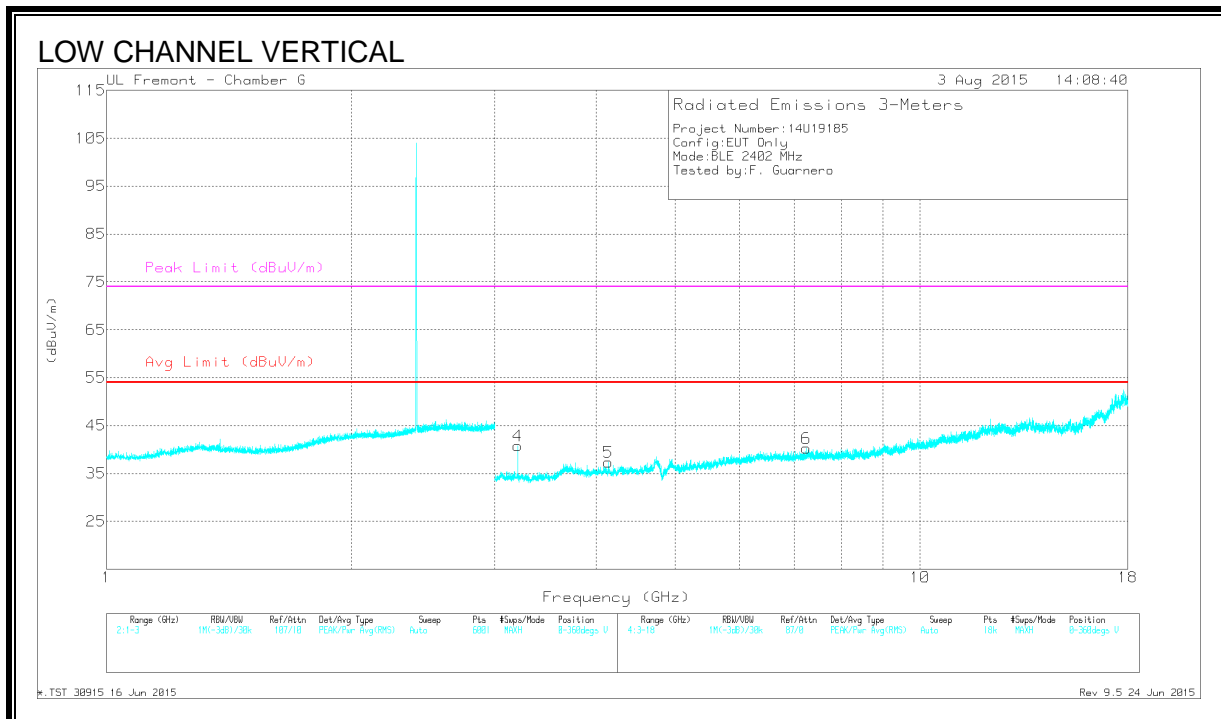
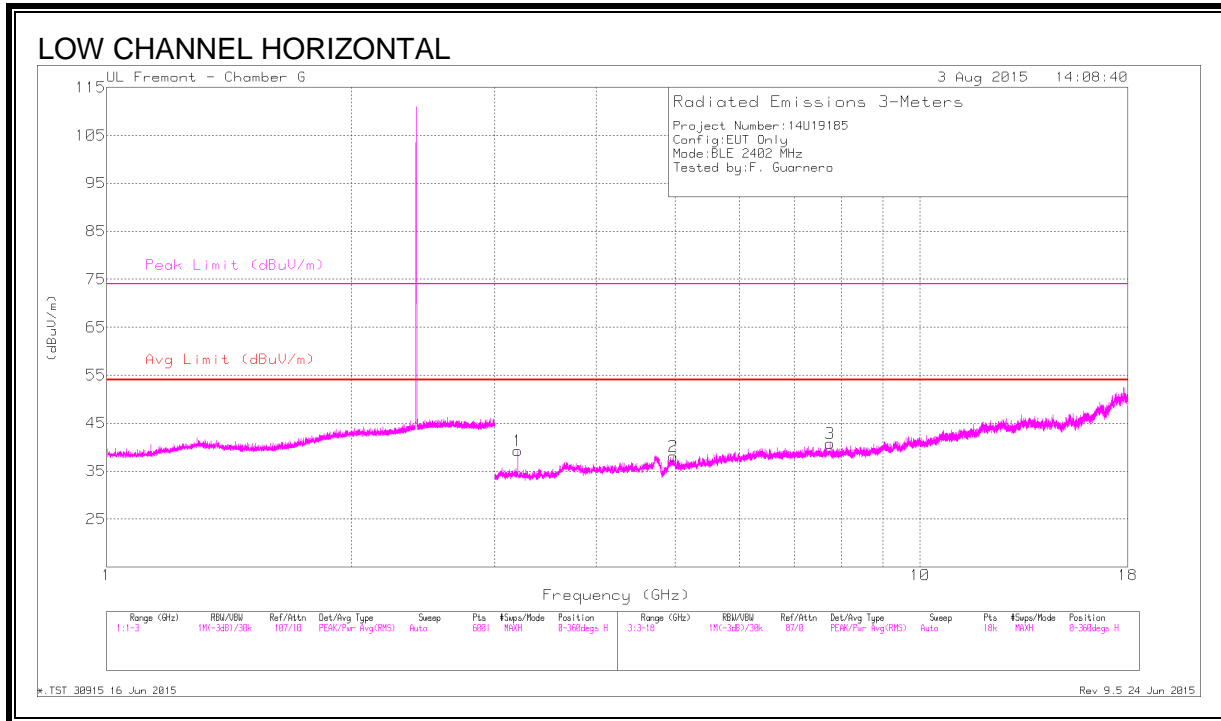

DATA

Marker	Frequency (GHz)	Meter Reading (dBuV)	Det	AF T862 (dB/m)	Amp/Cbl/ Fitr/Pad (dB)	Corrected Reading (dBuV/m)	Avg Limit (dBuV/m)	Margin (dB)	Peak Limit (dBuV/m)	PK Margin (dB)	Azimuth (Degs)	Height (cm)	Polarity
1	3.203	46.23	PK2	33.1	-33.3	46.03	-	-	-	-	241	239	H
2	* 4.973	42.88	PK2	34.2	-32.4	44.68	-	-	74	-29.32	109	172	H
	* 4.973	30.39	VA1T	34.2	-32.4	32.19	54	-21.81	-	-	109	172	H
3	7.753	40.9	PK2	35.6	-30.2	46.3	-	-	-	-	179	341	H
4	3.203	45.97	PK2	33.1	-33.3	45.77	-	-	-	-	310	101	V
5	* 4.137	43.85	PK2	33.3	-33.1	44.05	-	-	74	-29.95	286	111	V
	* 4.137	29.79	VA1T	33.3	-33	30.09	54	-23.91	-	-	286	111	V
6	7.249	41.08	PK2	35.6	-30.4	46.28	-	-	-	-	171	101	V

* - indicates frequency in CFR 47, Part 15 and Industry Canada RSS-Restricted Band.

PK2 - KDB558074 Method: Maximum Peak

MAv1 - KDB558074 Option 1 Maximum RMS Average

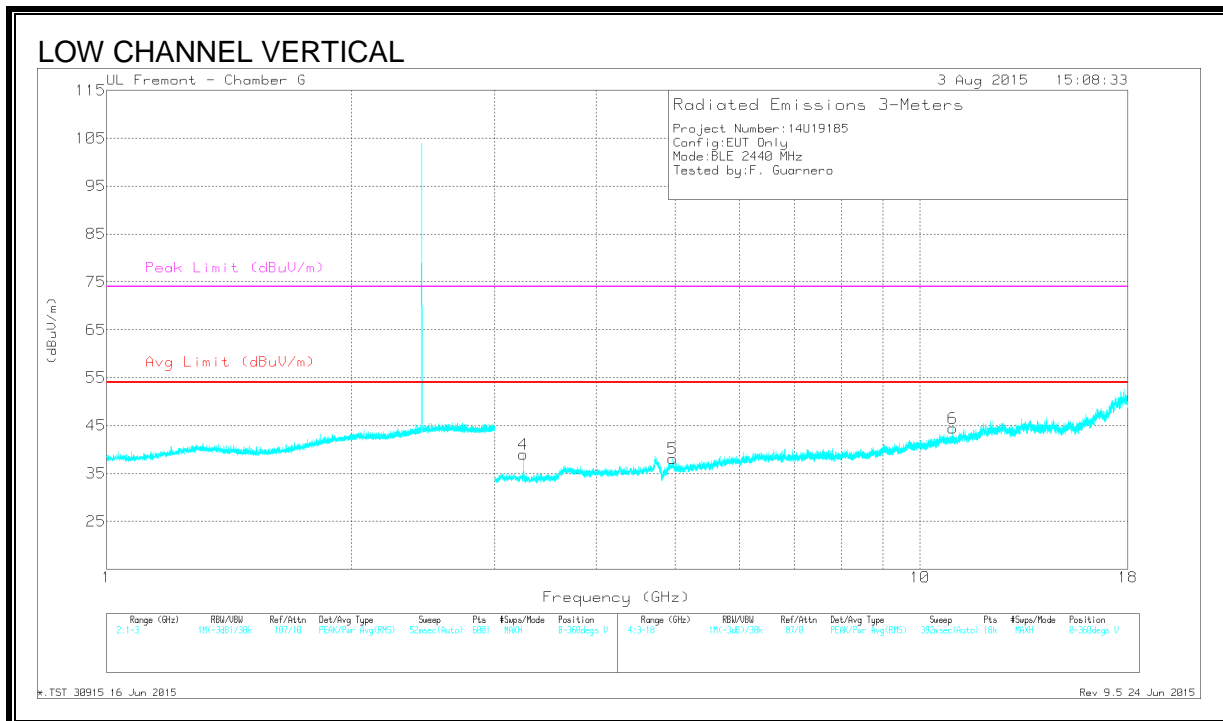
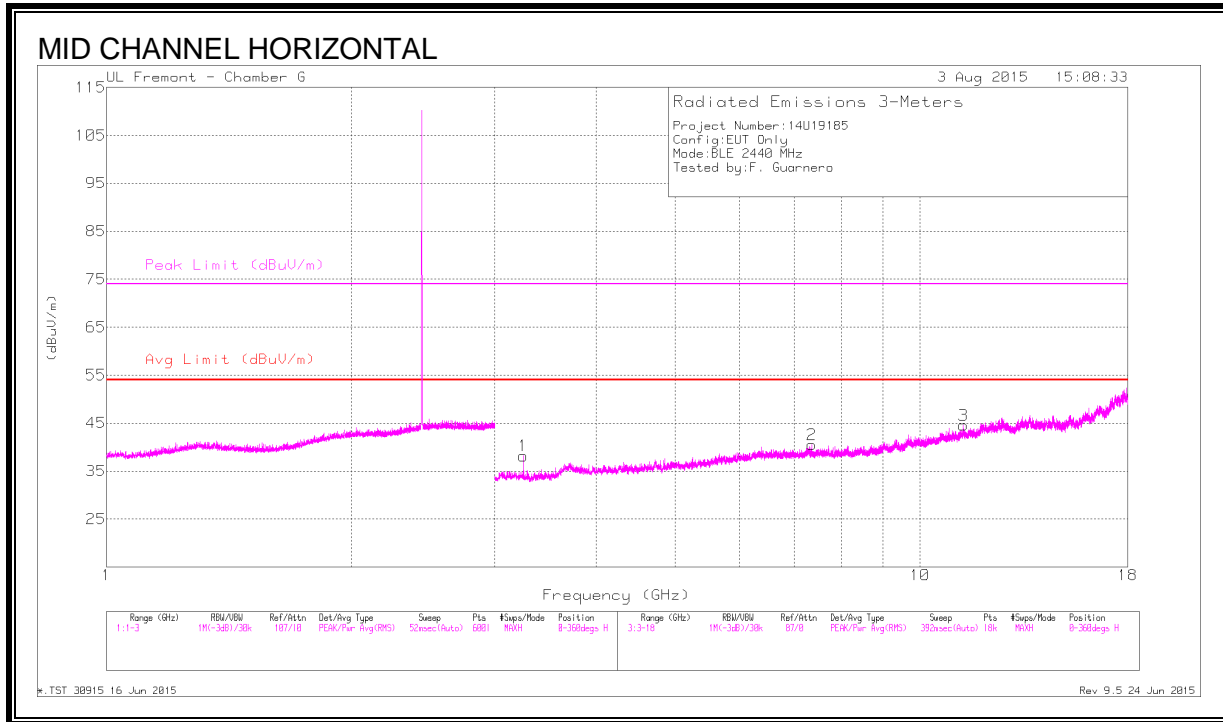

DATA

Markers	Frequency (GHz)	Meter Reading (dBuV)	Det	AF T862 (dB/m)	Amp/Cbl/Filtr/Pad (dB)	Corrected Reading (dBuV/m)	Avg Limit (dBuV/m)	Margin (dB)	Peak Limit (dBuV/m)	PK Margin (dB)	Azimuth (Degs)	Height (cm)	Polarity
1	3.254	44.53	PK2	32.9	-33.1	44.33	-	-	-	-	65	254	H
2	* 7.365	41.1	PK2	35.6	-30.8	45.9	-	-	74	-28.1	23	234	H
	* 7.363	28.62	VA1T	35.6	-30.8	33.42	54	-20.58	-	-	23	234	H
3	* 11.304	37.77	PK2	38	-25.1	50.67	-	-	74	-23.33	165	166	H
	* 11.302	24.9	VA1T	38	-25	37.9	54	-16.1	-	-	165	166	H
4	3.254	45.29	PK2	32.9	-33.1	45.09	-	-	-	-	138	102	V
5	* 4.964	43.06	PK2	34.2	-32.4	44.86	-	-	74	-29.14	124	114	V
	* 4.967	30.29	VA1T	34.2	-32.4	32.09	54	-21.91	-	-	124	114	V
6	* 10.963	37.55	PK2	37.9	-26	49.45	-	-	74	-24.55	64	136	V
	* 10.963	25	VA1T	37.9	-26	36.9	54	-17.1	-	-	64	136	V

* - indicates frequency in CFR 47, Part 15 and Industry Canada RSS-Restricted Band.

PK3 - FHSS Method: Maximum Peak

VB10Hz - FHSS Method: 10Hz Video Bandwidth

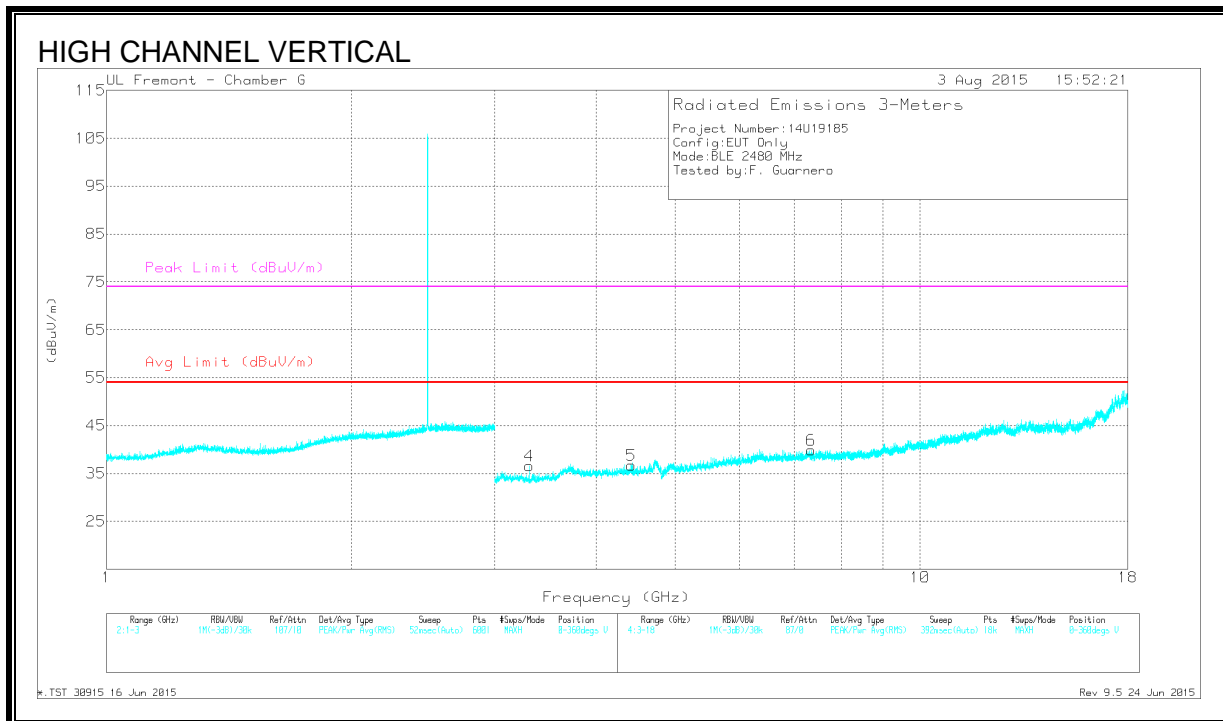
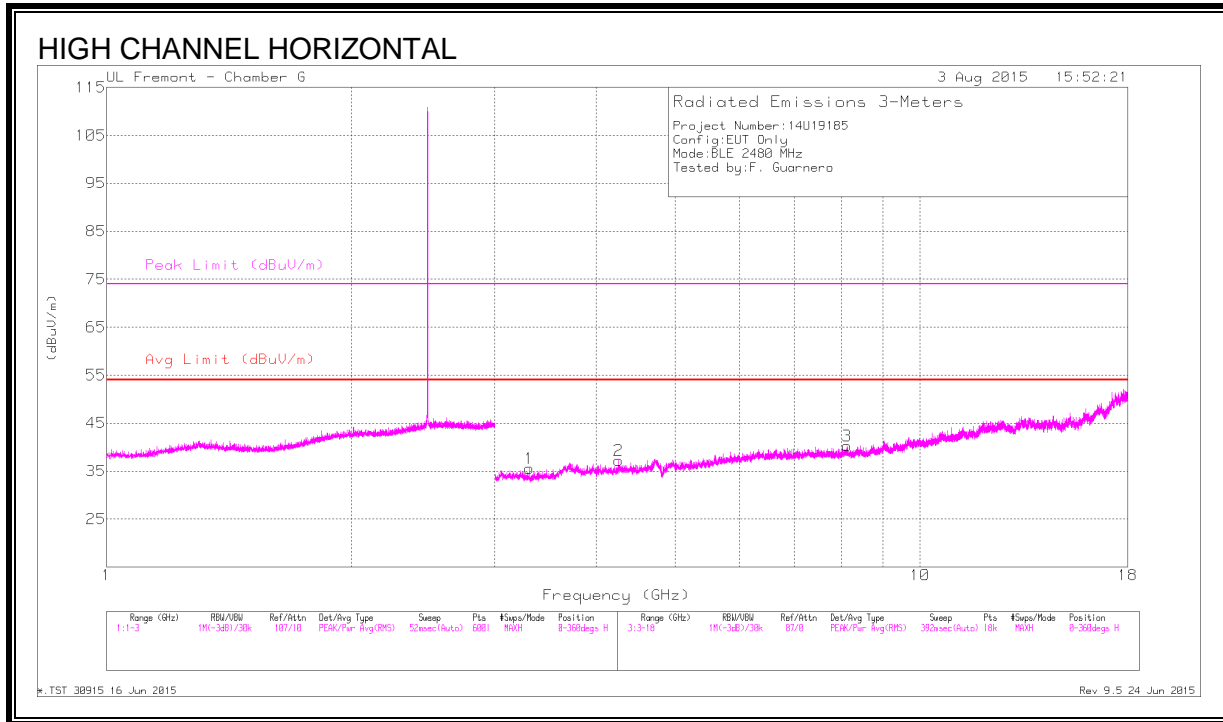

DATA

Marker	Frequency (GHz)	Meter Reading (dBuV)	Det	AF T862 (dB/m)	Amp/Cbl/Filtr/Pad (dB)	Corrected Reading (dBuV/m)	Avg Limit (dBuV/m)	Margin (dB)	Peak Limit (dBuV/m)	PK Margin (dB)	Azimuth (Degs)	Height (cm)	Polarity
1	3.306	44.05	PK2	32.7	-33.1	43.65	-	-	-	-	296	101	V
2	* 4.261	42.19	PK2	33.4	-32.2	43.39	-	-	74	-30.61	40	133	H
	* 4.262	29.17	VA1T	33.5	-32.1	30.57	54	-23.43	-	-	40	133	H
3	* 8.131	40.32	PK2	35.7	-29.4	46.62	-	-	74	-27.38	198	128	H
	* 8.129	27.63	VA1T	35.7	-29.4	33.93	54	-20.07	-	-	198	128	H
4	3.307	43.9	PK2	32.7	-33.1	43.5	-	-	-	-	249	100	H
5	4.421	42.89	PK2	33.6	-32.6	43.89	-	-	-	-	140	182	V
6	* 7.348	40.82	PK2	35.6	-30.6	45.82	-	-	74	-28.18	269	278	V
	* 7.348	28.21	VA1T	35.6	-30.6	33.21	54	-20.79	-	-	269	278	V

* - indicates frequency in CFR 47, Part 15 and Industry Canada RSS-Restricted Band.

PK2 - KDB558074 Method: Maximum Peak

MAv1 - KDB558074 Option 1 Maximum RMS Average

8.3. WORST CASE CO-LOCATION

BLUETOOTH LOW ENERGY AND 802.11 HT20 2Tx CDD MODE IN THE 5.6GHz BAND

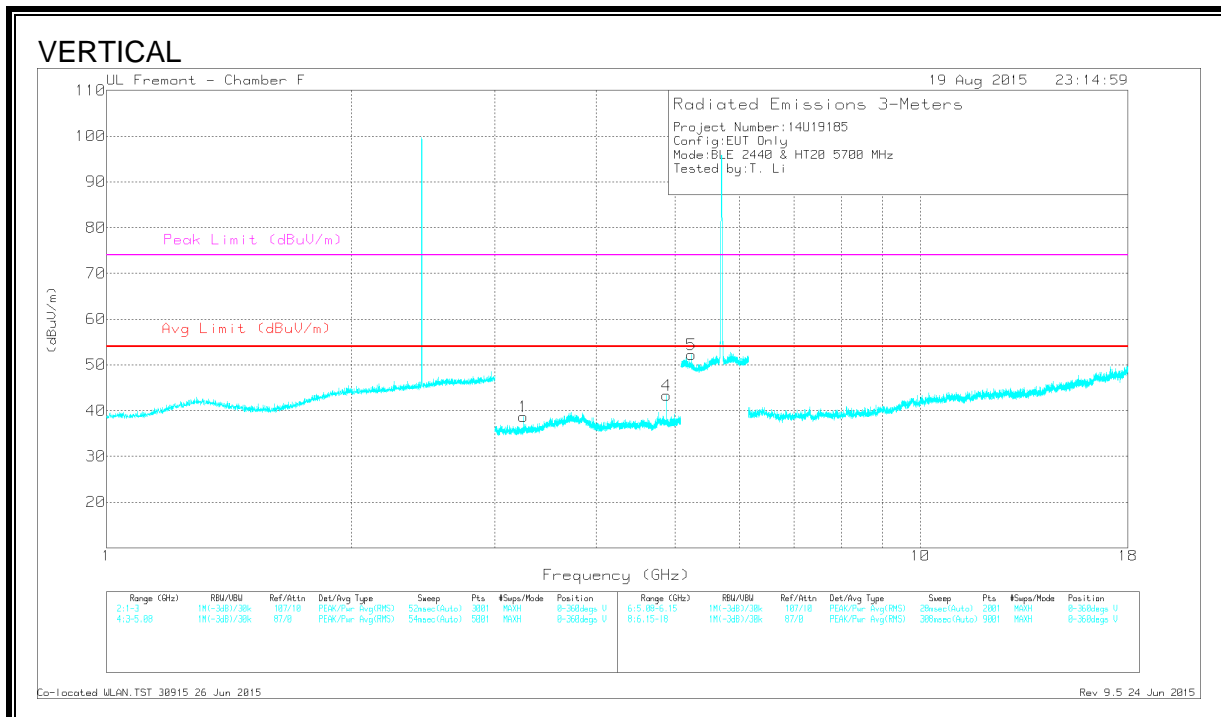
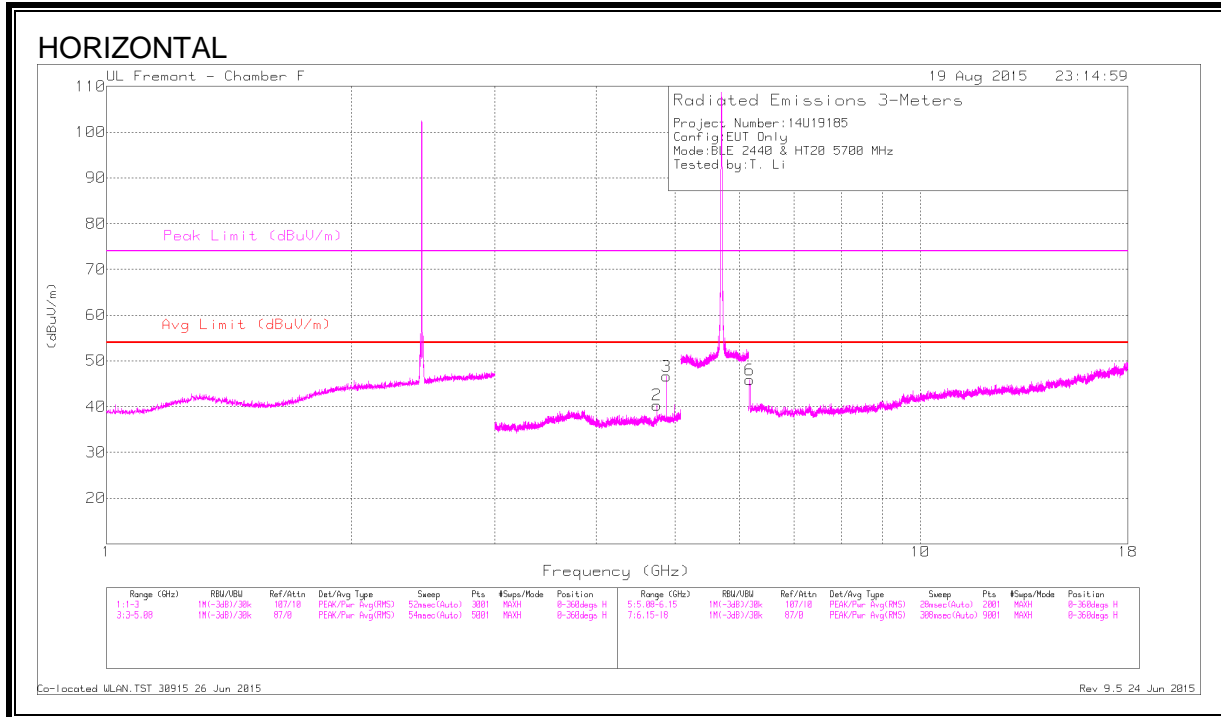

DATA

Marker	Frequency (GHz)	Meter Reading (dBuV)	Det	AF T120 (dB/m)	Amp/Cb/F ltr/Pad (dB)	Corrected Reading (dBuV/m)	Avg Limit (dBuV/m)	Margin (dB)	Peak Limit (dBuV/m)	Margin (dB)	Azimuth (Degs)	Height (cm)	Polarity
2	* 4.75	40.89	PK2	34.1	-28.4	46.59	-	-	74	-27.41	0	176	H
	* 4.75	32.42	MAv1	34.1	-28.4	38.12	53.97	-15.85	-	-	0	176	H
3	* 4.881	43.96	PK2	34.1	-27.9	50.16	-	-	74	-23.84	283	248	H
	* 4.88	37.91	MAv1	34.1	-27.9	44.11	53.97	-9.86	-	-	283	248	H
1	3.253	41.27	PK2	33.2	-29.1	45.37	-	-	74	-28.63	8	100	V
4	* 4.879	41.17	PK2	34.1	-27.9	47.37	-	-	74	-26.63	347	189	V
	* 4.88	33.55	MAv1	34.1	-27.9	39.75	53.97	-14.22	-	-	347	189	V
5	5.237	41.68	PK2	34.4	-18.4	57.68	-	-	74	-16.32	67	119	V
6	6.172	44.03	PK2	35.7	-26.7	53.03	-	-	74	-20.97	283	100	H

* - indicates frequency in CFR15.205/IC8.10 Restricted Band

PK2 - KDB558074 Method: Maximum Peak

MAv1 - KDB558074 Option 1 Maximum RMS Average

8.4. WORST-CASE BELOW 1 GHz

SPURIOUS EMISSIONS 30 TO 1000 MHz (WORST-CASE CONFIGURATION)

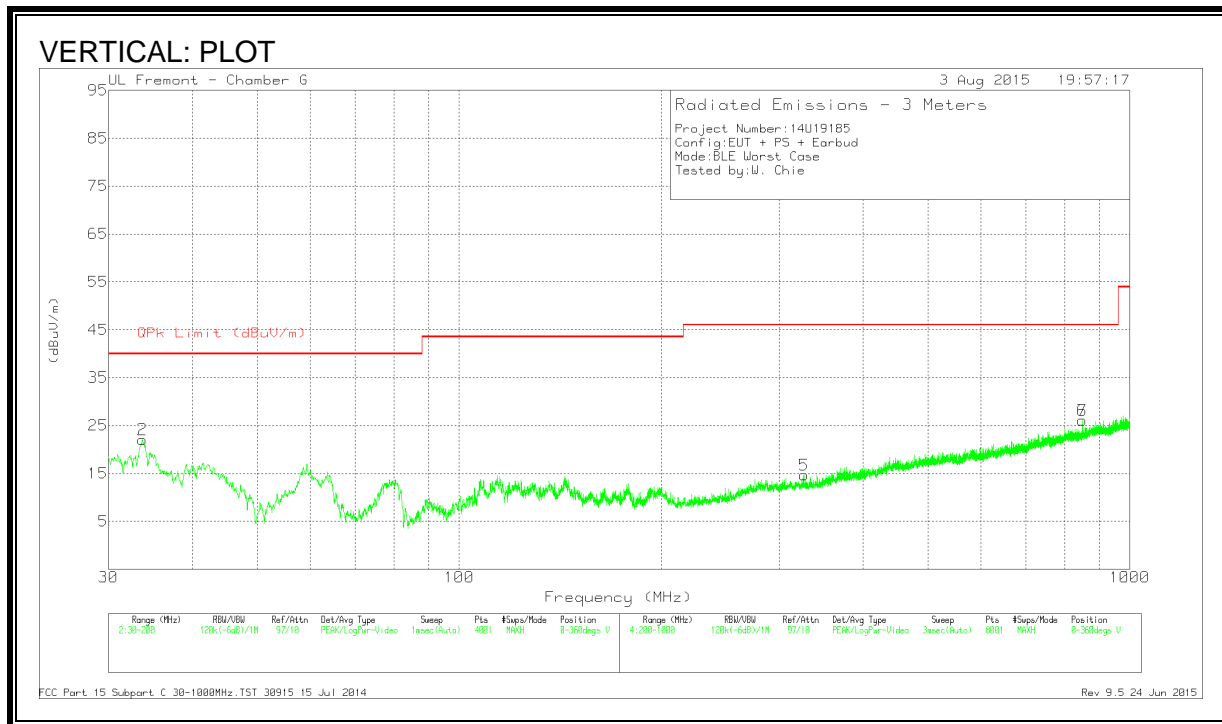
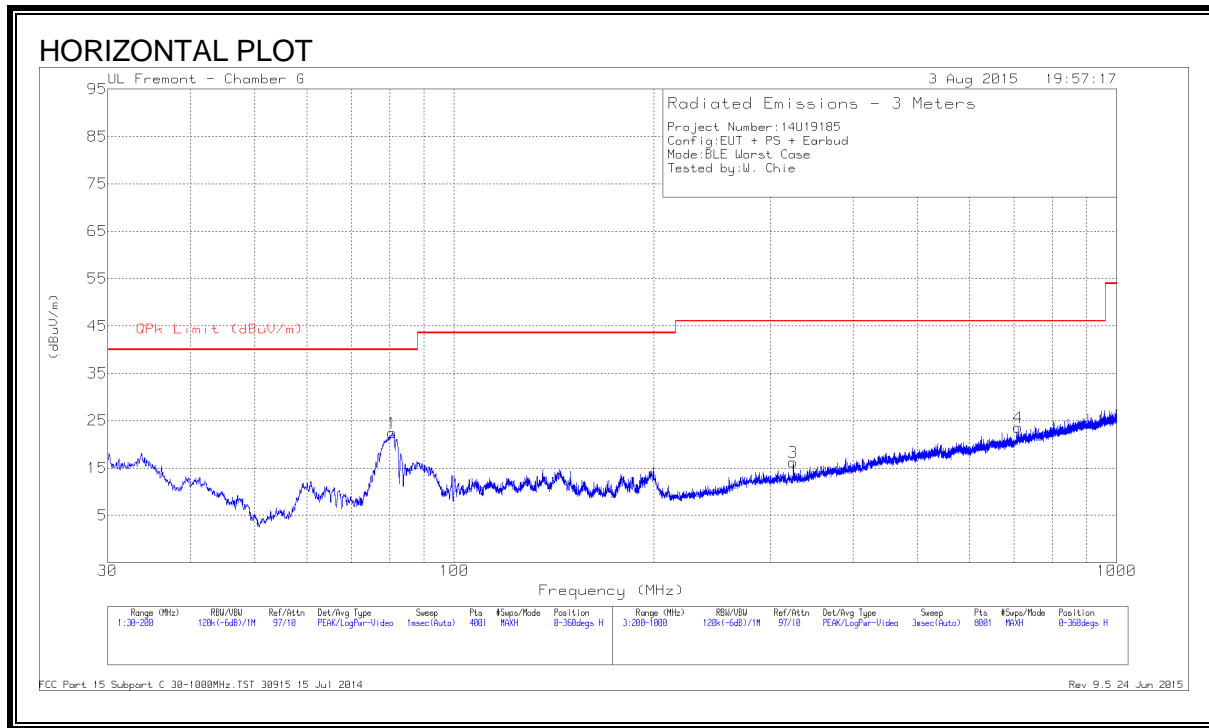

DATA

Marker	Frequency (MHz)	Meter Reading (dBuV)	Det	AF T899 (dB/m)	Amp Cbl (dB)	Corrected Reading (dBuV/m)	QPk Limit (dBuV/m)	Margin (dB)	Azimuth (Degs)	Height (cm)	Polarity
1	80.66	45.54	Pk	7.6	-30.7	22.44	40	-17.56	0-360	201	H
2	33.6975	34.31	Pk	19.1	-31.3	22.11	40	-17.89	0-360	100	V
3	* 325	31.16	Pk	13.8	-28.7	16.26	46.02	-29.76	0-360	100	H
4	709.7	30.47	Pk	20.2	-27.1	23.57	46.02	-22.45	0-360	201	H
5	* 326.5	29.73	Pk	13.8	-28.8	14.73	46.02	-31.29	0-360	100	V
6	849.85	31	Pk	21.5	-26.4	26.1	46.02	-19.92	0-360	100	V
7	849.85	31	Pk	21.5	-26.4	26.1	46.02	-19.92	0-360	100	V

* - indicates frequency in CFR15.205/IC8.10 Restricted Band

Pk - Peak detector

* - indicates frequency in CFR 47, Part 15 and Industry Canada RSS-Restricted Band.

PK - Peak detector

8.5. WORST-CASE 18 to 26 GHz

SPURIOUS EMISSIONS 18 to 26 GHz (WORST-CASE CONFIGURATION, HORIZONTAL)

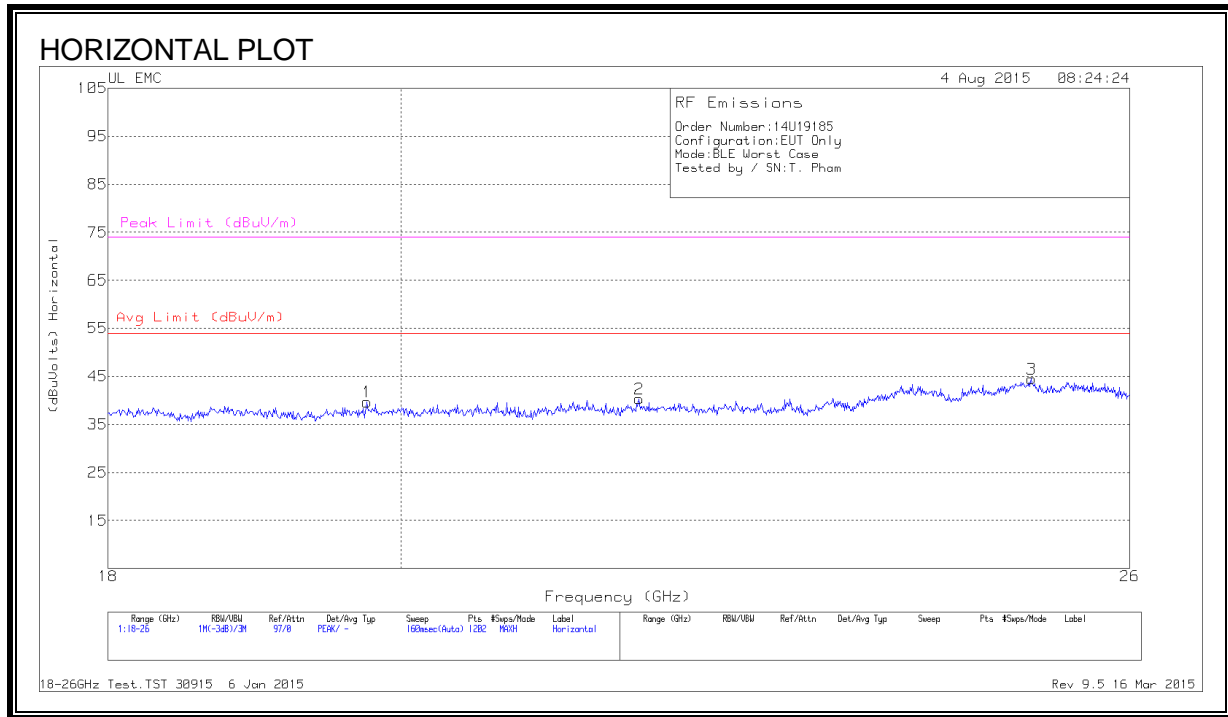

SPURIOUS EMISSIONS 18 to 26 GHz (WORST-CASE CONFIGURATION, VERTICAL)

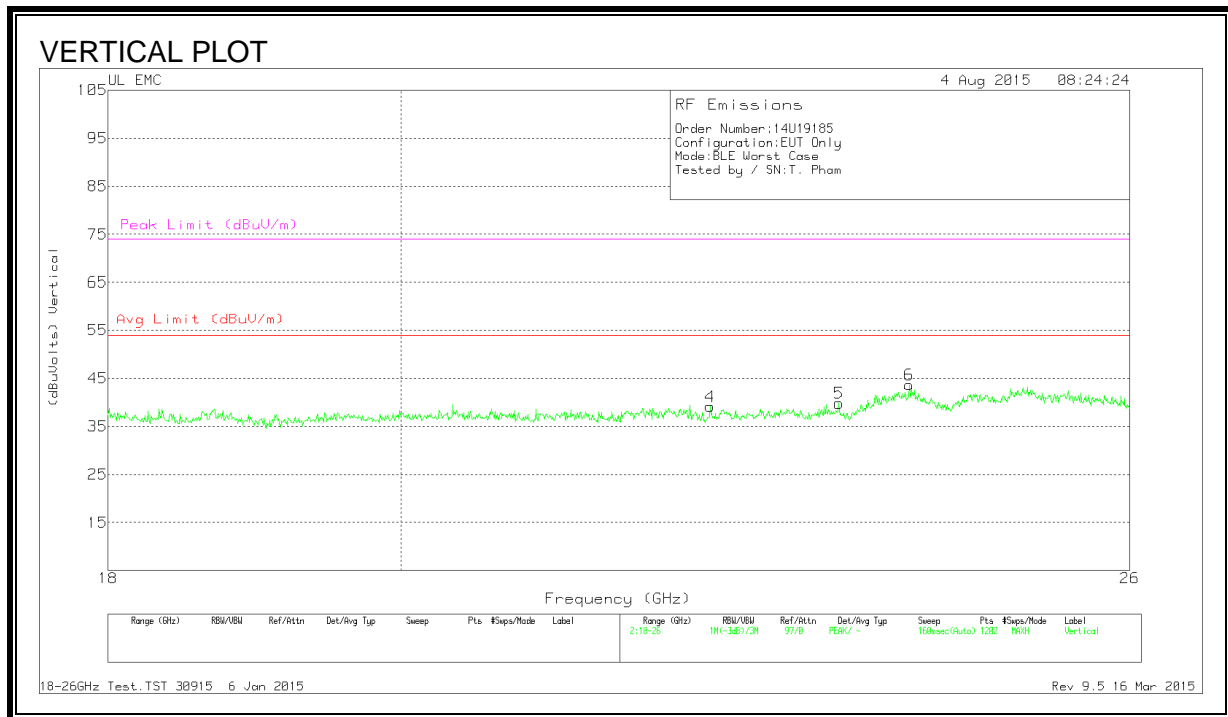

DATA

Marker	Frequency (GHz)	Meter Reading (dBuV)	Det	T89 AF (dB/m)	Amp/Cbl (dB)	Dist Corr (dB)	Corrected Reading (dBuVolts)	Avg Limit (dBuV/m)	Margin (dB)	Peak Limit (dBuV/m)	PK Margin (dB)
1	19.759	41.57	Pk	32.5	-24.9	-9.5	39.67	54	-14.33	74	-34.33
2	21.79	41.33	Pk	33.3	-24.8	-9.5	40.33	54	-13.67	74	-33.67
3	25.094	44.6	Pk	33.9	-24.5	-9.5	44.5	54	-9.5	74	-29.5
4	22.356	40.37	Pk	33	-24.7	-9.5	39.17	54	-14.83	74	-34.83
5	23.415	40.43	Pk	33.3	-24.4	-9.5	39.83	54	-14.17	74	-34.17
6	24.015	44.17	Pk	33.3	-24.3	-9.5	43.67	54	-10.33	74	-30.33

Pk - Peak detector

9. AC POWER LINE CONDUCTED EMISSIONS

LIMITS

FCC §15.207 (a)

RSS-Gen 8.8

Frequency of Emission (MHz)	Conducted Limit (dB μ V)	
	Quasi-peak	Average
0.15-0.5	66 to 56 *	56 to 46 *
0.5-5	56	46
5-30	60	50

*Decreases with the logarithm of the frequency.

TEST PROCEDURE

The EUT is placed on a non-conducting table 40 cm from the vertical ground plane and 80 cm above the horizontal ground plane. The EUT is configured in accordance with ANSI C63.10.

The receiver is set to a resolution bandwidth of 9 kHz. Peak detection is used unless otherwise noted as quasi-peak or average.

Line conducted data is recorded for both NEUTRAL and HOT lines.

9.1. EUT POWERED BY AC/DC ADAPTER VIA USB CABLE

6 WORST EMISSIONS

Range 1: Line-L1 .15 - 30MHz

Marker	Frequency (MHz)	Meter Reading (dBuV)	Det	T24 IL L1	LC Cables 1&3	Corrected Reading dBuV	CISPR 22 Class B QP	Margin (dB)	CISPR 22 Class B Avg	Margin (dB)
1	.1815	37.53	Pk	1.1	0	38.63	64.42	-25.79	-	-
2	.1815	27.53	Av	1.1	0	28.63	-	-	54.42	-25.79
3	.2265	36.29	Pk	.8	0	37.09	62.58	-25.49	-	-
4	.2265	26.8	Av	.8	0	27.6	-	-	52.58	-24.98
5	.2715	35.3	Pk	.6	0	35.9	61.07	-25.17	-	-
6	.2715	26.22	Av	.6	0	26.82	-	-	51.07	-24.25
7	.609	37.74	Pk	.3	0	38.04	56	-17.96	-	-
8	.6045	27.57	Av	.3	0	27.87	-	-	46	-18.13
9	18.987	41.06	Pk	.3	.2	41.56	60	-18.44	-	-
10	18.9465	25.01	Av	.3	.2	25.51	-	-	50	-24.49

Range 2: Line-L2 .15 - 30MHz

Marker	Frequency (MHz)	Meter Reading (dBuV)	Det	T24 IL L2	LC Cables 2&3	Corrected Reading dBuV	CISPR 22 Class B QP	Margin (dB)	CISPR 22 Class B Avg	Margin (dB)
11	.1815	38.36	Pk	1.2	0	39.56	64.42	-24.86	-	-
12	.1815	25.17	Av	1.2	0	26.37	-	-	54.42	-28.05
13	.2265	37.97	Pk	.9	0	38.87	62.58	-23.71	-	-
14	.2265	23.58	Av	.9	0	24.48	-	-	52.58	-28.1
15	.26925	37.01	Pk	.7	0	37.71	61.14	-23.43	-	-
16	.2715	22.24	Av	.7	0	22.94	-	-	51.07	-28.13
17	.3165	36.21	Pk	.6	0	36.81	59.8	-22.99	-	-
18	.3165	20.44	Av	.6	0	21.04	-	-	49.8	-28.76
19	.609	32.71	Pk	.3	0	33.01	56	-22.99	-	-
20	.609	19.26	Av	.3	0	19.56	-	-	46	-26.44
21	8.25	30.51	Pk	.2	.1	30.81	60	-29.19	-	-
22	8.259	20.77	Av	.2	.1	21.07	-	-	50	-28.93

Pk - Peak detector
 Av - Average detection

LINE 1 RESULTS

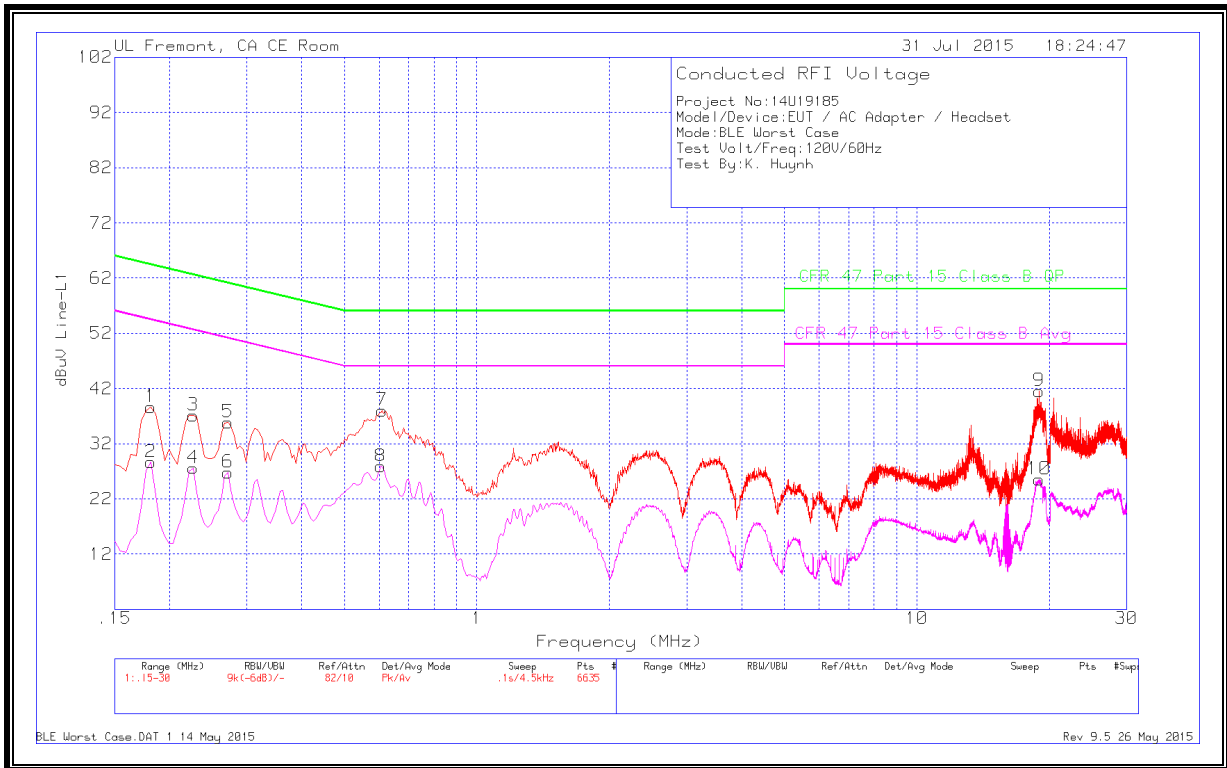

LINE 2 RESULTS

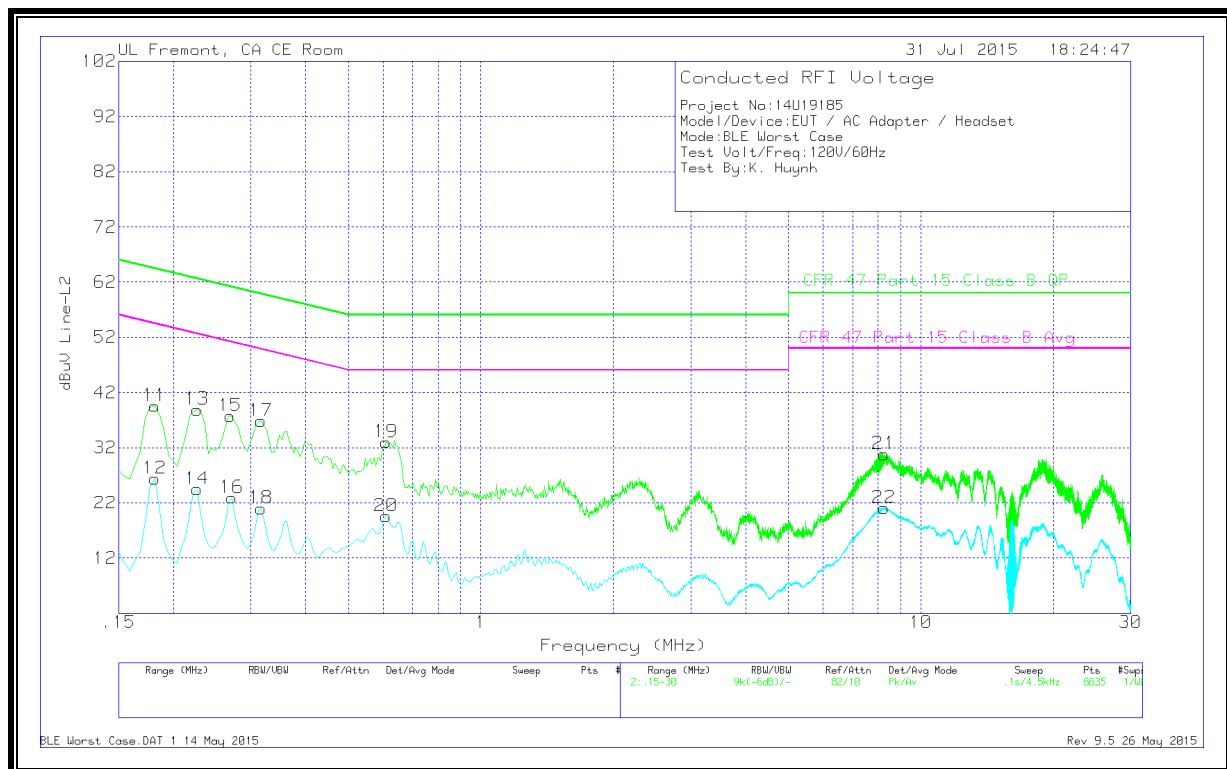

9.2. EUT POWERED BY HOST PC VIA USB CABLE

6 WORST EMISSIONS

Range 1: Line-L1 .15 - 30MHz

Marker	Frequency (MHz)	Meter Reading (dBuV)	Det	T24 IL L1	LC Cables 1&3	Corrected Reading dBuV	CISPR 22 Class B QP	Margin (dB)	CISPR 22 Class B Avg	Margin (dB)
1	.1545	51.7	Pk	1.3	0	53	65.75	-12.75	-	-
2	.1545	44.58	Av	1.3	0	45.88	-	-	55.75	-9.87
3	.4785	36.94	Pk	.4	0	37.34	56.37	-19.03	-	-
4	.4695	26.67	Av	.4	0	27.07	-	-	46.52	-19.45
5	.78	37.63	Pk	.3	0	37.93	56	-18.07	-	-
6	.78	25.17	Av	.3	0	25.47	-	-	46	-20.53
7	1.392	38.44	Pk	.2	.1	38.74	56	-17.26	-	-
8	1.392	23.84	Av	.2	.1	24.14	-	-	46	-21.86
9	13.3665	45.83	Pk	.2	.2	46.23	60	-13.77	-	-
10	13.3305	26.62	Av	.2	.2	27.02	-	-	50	-22.98
11	18.7395	45.35	Pk	.3	.2	45.85	60	-14.15	-	-
12	18.717	28.5	Av	.3	.2	29	-	-	50	-21

Range 2: Line-L2 .15 - 30MHz

Marker	Frequency (MHz)	Meter Reading (dBuV)	Det	T24 IL L2	LC Cables 2&3	Corrected Reading dBuV	CISPR 22 Class B QP	Margin (dB)	CISPR 22 Class B Avg	Margin (dB)
13	.15	51.81	Pk	1.5	0	53.31	66	-12.69	-	-
14	.15	44.68	Av	1.5	0	46.18	-	-	56	-9.82
15	.4245	33.39	Pk	.4	0	33.79	57.36	-23.57	-	-
16	.4335	17.01	Av	.4	0	17.41	-	-	47.19	-29.78
17	.7935	34.81	Pk	.3	0	35.11	56	-20.89	-	-
18	.7305	22.14	Av	.3	0	22.44	-	-	46	-23.56
19	13.3215	51.48	Pk	.2	.2	51.88	60	-8.12	-	-
20	13.317	36.29	Av	.2	.2	36.69	-	-	50	-13.31
21	18.825	46.27	Pk	.3	.2	46.77	60	-13.23	-	-
22	18.7575	31.89	Av	.3	.2	32.39	-	-	50	-17.61

Pk - Peak detector
 Av - Average detection

LINE 1 RESULTS

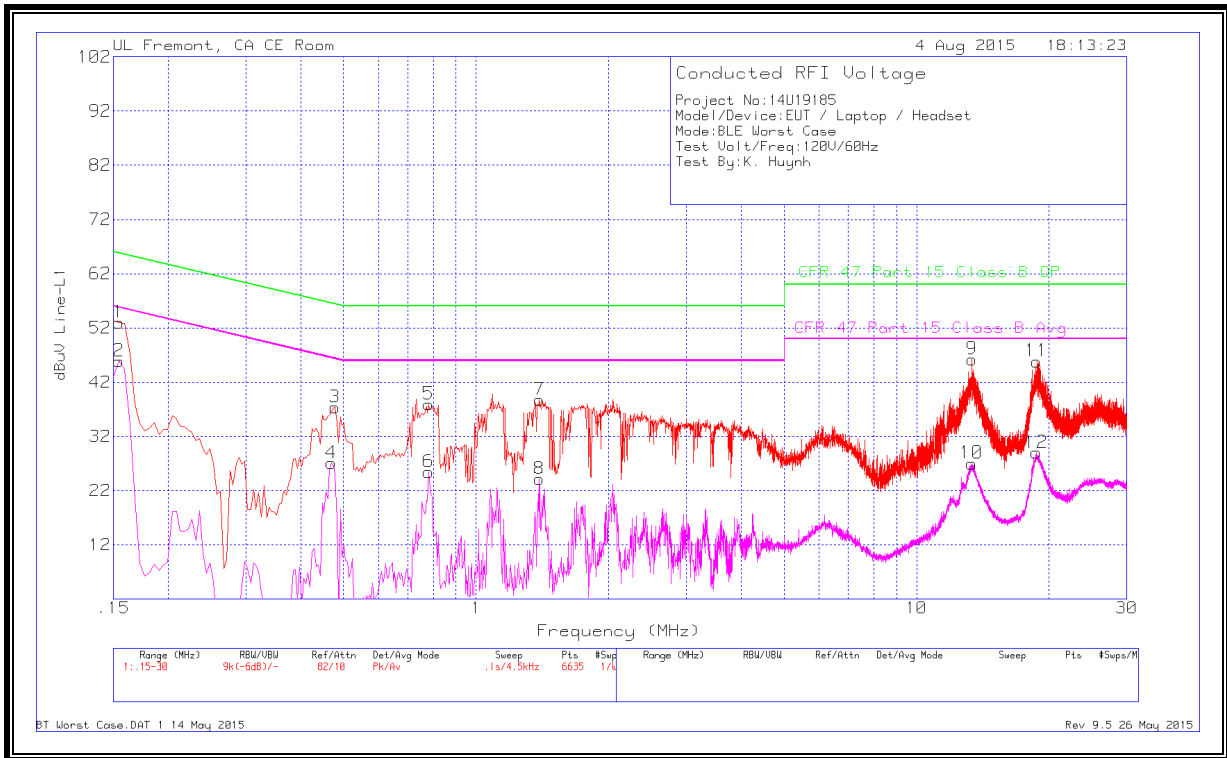

LINE 2 RESULTS

